

Synchronous Motors

S Line – Vertical With Brushes

Installation, Operation and Maintenance Manual

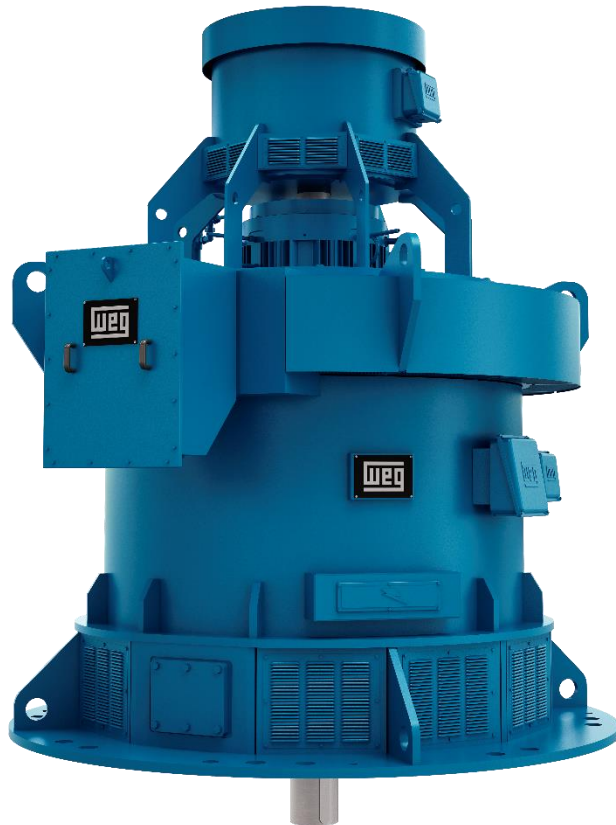



Installation, Operation and Maintenance Manual

Model: SDA, SDD, SDT, SDV, SDF, SDR, SDI, SDW and SDL

Document Number: 17534793

Language: English

Review: 02

March 2025

Dear Customer,

Thank you for purchasing a WEG motor. Our products are developed with the highest standards of quality and efficiency which ensures outstanding performance.

As the electric motor plays a role of great importance to the comfort and well-being of the humanity, it must be identified and treated as an electrical machine, whose features require certain precautions, such as for storage, installation and maintenance.

All efforts have been made to ensure that the information contained in this manual is faithful to the configurations and operation of the motor.

Therefore, we recommend that you read this manual carefully before proceeding with the installation, operation or maintenance of the motor in order to ensure safe and reliable operation of your equipment and facility. If you need any further information, please contact WEG.

Always keep this manual close to the motor, so it can be consulted whenever necessary.



ATTENTION

1. It is imperative to follow the procedures contained in this manual for the warranty to be valid;
2. The motor installation, operation and maintenance procedures must be performed only by qualified personnel.



NOTES

1. The total or partial reproduction of information supplied in this manual is authorized, provided that reference is made to its source.
2. If this manual is lost, an electronic PDF file is available at www.weg.net or another printed copy may be requested.
3. All machines are equipped with a unique QR code located next to the machine's nameplate. This QR code provides quick and easy access to various services, including:
 - Technical support
 - Spare parts
 - Commissioning
 - General and maintenance services in the field and at the factory

To use this feature, simply scan the QR code with your mobile device. Be sure to keep this manual on hand for future reference and to ensure the correct and safe use of the electric motor.

WEG EQUIPAMENTOS ELÉTRICOS S.A.

INDEX

1	INTRODUCTION	11
1.1	SAFETY WARNINGS IN THE MANUAL	11
2	GENERAL INSTRUCTIONS	12
2.1	QUALIFIED PERSONNEL	12
2.2	SAFETY INSTRUCTIONS	12
2.3	STANDARDS	12
2.4	ENVIRONMENTAL CONDITIONS	12
2.5	OPERATING CONDITIONS	13
2.6	VOLTAGE AND FREQUENCY	13
3	RECEIVING, STORAGE AND HANDLING	14
3.1	RECEIVING	14
3.2	HANDLING	14
3.2.1	Motor Positioning.....	14
3.3	STORAGE	15
3.3.1	Indoor storage	15
3.3.2	Outdoor storage.....	15
3.3.3	Extended storage.....	15
3.3.3.1	Storage location.....	15
3.3.3.1.1	Indoor storage.....	15
3.3.3.1.2	Outdoor storage.....	15
3.3.3.2	Separate parts.....	16
3.3.3.3	Space heater.....	16
3.3.3.4	Insulation resistance	16
3.3.3.5	Exposed machined surfaces	16
3.3.3.6	Sleeve bearing	16
3.3.3.7	Terminal box	16
3.3.3.8	Radiator.....	17
3.3.3.9	Inspections and records during storage	17
3.3.3.10	Preparation for commissioning	17
3.3.3.10.1	Cleaning	17
3.3.3.10.2	Bearing lubrication	17
3.3.3.10.3	Checking the insulation resistance	17
3.3.3.10.4	Others.....	17
3.3.3.11	Maintenance plan during storage	18
3.3.4	Preparation for commissioning	19
3.3.4.1	Cleaning	19
3.3.4.2	Bearing inspection.....	19
3.3.4.3	Bearing lubrication.....	19
3.3.4.4	Brushes, brush holders and slip rings	19
3.3.4.5	Insulation resistance verification.....	19
3.3.4.6	Air-water heat exchanger	19
3.3.4.7	Others	19
4	INSTALLATION.....	20
4.1	INSTALLATION SITE.....	20
4.2	SHAFT LOCK.....	20
4.3	DIRECTION OF ROTATION.....	20
4.4	INSULATION RESISTANCE	20
4.4.1	Safety instructions	20
4.4.2	General considerations.....	20
4.4.3	Stator winding measuring.....	20
4.4.4	Measurement on the rotor winding	21
4.4.5	Polarization index	21
4.4.6	Conversion of the measured values	21
4.4.7	Recommended Minimum Values.....	22
4.5	PROTECTIONS	22
4.5.1	Thermal protections.....	22
4.5.1.1	Temperature sensors	22
4.5.1.2	Temperature limits for the windings.....	22
4.5.1.3	Alarm and trip temperatures.....	23
4.5.1.4	Temperature and ohmic resistance of the PT100 thermoresistance	24
4.5.2	Space heater	24
4.5.3	Water leak sensor	24

4.6	COOLING	25
4.6.1	Water radiators	25
4.6.1.1	Radiators for application with sea water	25
4.6.1.2	Independent ventilation cooling	25
4.6.1.3	Air/Air heat exchanger cleaning	25
4.7	ELECTRICAL ASPECTS	26
4.7.1	Electric connections	26
4.7.1.1	Main electrical connection	26
4.7.1.2	Grounding	26
4.7.1.3	Field power supply and control	26
4.7.2	Connection diagram	26
4.8	MECHANICAL ASPECTS	26
4.8.1	Foundations	26
4.8.2	Foundations loads	27
4.8.3	Metal base	27
4.8.4	Motor mounting	27
4.8.5	Natural frequency of the base	27
4.8.6	Alignment of the motor with the driven machine	27
4.8.7	Couplings	28
4.8.7.1	Direct coupling	28
4.8.7.2	Gear coupling	28
4.8.8	Anchor plate set	28
4.8.9	Leveling	29
4.8.10	Support	29
4.9	BRAKE	29
4.10	HYDRAULIC UNIT	29
5	STARTING	30
5.1	DIRECT ON LINE STARTING	30
5.1.1	Direct start with discharge resistor	30
5.1.2	Direct start without discharge resistor	30
5.1.3	Direct start frequency	30
5.1.4	Locked rotor current (Ip/In)	30
5.2	STARTING WITH REDUCED CURRENT	31
5.2.1	Starting with reactor	31
5.2.2	Starting with autotransformer	31
5.2.3	Starting with frequency inverter	31
5.2.4	Starting with soft-starter	31
5.3	EXCITATION CIRCUIT	32
5.3.1	Excitation circuit with voltage control (Random)	32
6	COMMISSIONING	33
6.1	PRELIMINARY INSPECTION	33
6.2	FIRST START	33
6.2.1	Initial starting procedure	33
6.3	OPERATION	34
6.3.1	Re-synchronization	34
6.3.2	Data recording	34
6.3.3	Temperatures	34
6.3.4	Bearings	34
6.3.4.1	High-pressure oil injection system	35
6.3.5	Radiators	35
6.3.5.1	Inspection of the performance of the radiator	35
6.4	SHUTDOWN	35
7	MAINTENANCE	36
7.1	GENERAL	36
7.2	GENERAL CLEANING	36
7.3	BRUSHES COMPARTMENT CLEANING	36
7.4	WINDINGS INSPECTION	36
7.5	WINDING CLEANING	36
7.5.1	Inspections	36
7.5.2	Re-impregnation	37
7.5.3	Insulation resistance	37
7.6	COOLING SYSTEM MAINTENANCE	37
7.6.1	Radiators	37
7.7	VIBRATION	37
7.8	SLIP RINGS	37

7.9	BRUSH HOLDER AND BRUSHES	37
7.10	SHAFT GROUNDING DEVICE	38
7.11	EXCITER MAINTENANCE	38
7.11.1	Exciter	38
7.12	BEARING MAINTENANCE	38
7.12.1	Grease-lubricated rolling bearings.....	38
7.12.1.1	Lubrication instructions.....	38
7.12.1.2	Procedures for rolling bearing relubrication	39
7.12.1.3	Rolling bearing relubrication with drawer device for grease removal.....	39
7.12.2	Type and amount of grease.....	39
7.12.3	Grease compatibility	39
7.12.4	Bearing disassembly	39
7.12.4.1	Bearing assembly	40
7.12.5	Oil-lubricated rolling bearing.....	40
7.12.5.1	Lubrication instructions.....	40
7.12.5.2	Oil type	40
7.12.5.3	Oil change	40
7.12.5.4	Bearing operation	41
7.12.5.5	Bearing disassembly	41
7.12.5.6	Bearing assembly.....	41
7.12.6	Sleeve bearings.....	41
7.12.6.1	Bearing data	41
7.12.6.2	Bearing installation and operation	42
7.12.6.3	Cooling by water circulation.....	42
7.12.6.4	Oil change	42
7.12.7	Sealings.....	42
7.12.8	Sleeve bearing operation.....	42
7.12.9	Sleeve bearing maintenance	43
7.12.10	Protection setting.....	43
7.12.11	Disassembly/assembly of the bearing temperature sensors	43
8	MOTOR DISASSEMBLY AND ASSEMBLY	44
8.1	PARTS	44
8.2	DISASSEMBLY	44
8.3	ASSEMBLY	45
8.4	AIR GAP MEASUREMENT.....	45
8.5	GENERAL RECOMMENDATIONS	45
9	MAINTENANCE PLAN.....	46
10	ABNORMALITIES, CAUSES AND SOLUTIONS.....	47
11	DECLARATION OF CONFORMITY	49
12	ENVIRONMENTAL INFORMATION	50
12.1	PACKAGE	50
12.2	PRODUCT	50
12.3	HAZARDOUS WASTE.....	50
13	SERVICE NETWORK.....	50
14	WARRANTY TERMS	51

1 INTRODUCTION

This manual contains information regarding low and high voltage synchronous motors.

Motors are supplied with specific documents (drawings, connection diagram, characteristic curves, etc.). Those documents, together with this manual, must be thoroughly evaluated before proceeding with the installation, operation or maintenance of the motor.

All the procedures and standards contained in this manual must be observed in order to ensure proper operation of the motor and the safety of the personnel involved. Following these procedures is also important to ensure the validity of the motor warranty. Thus, we recommend carefully reading this manual before performing the installation, operation or maintenance of the motor. If you need any further information, consult WEG.

1.1 SAFETY WARNINGS IN THE MANUAL

In this manual, the following safety warnings are used:



DANGER

Failure to observe the procedures recommend in this warning may result in death, serious injuries and extensive equipment damage.



ATTENTION

Failure to observe the procedures recommend in this warning may result in equipment damage.



NOTE

This provides important information for correct understanding and proper operation of the product.

2 GENERAL INSTRUCTIONS

All personnel involved with the assembly, operation or maintenance of electrical installations must be informed and updated on the standards and safety instructions that guide the job and are advised to strictly comply with them. Before beginning any job, the person in charge must make sure that all points have been duly observed and warn the respective personnel about the danger inherent to the task to be performed.

Improper application, inadequate handling or maintenance of the motor, may cause serious injuries and/or material damages.

Therefore, it is highly recommended that such jobs be always performed by qualified personnel.

2.1 QUALIFIED PERSONNEL

The term qualified personnel means those who, because of their training, experience, education level and knowledge of the applicable standards, specifications, accident prevention, safety standards and operating conditions, have been authorized by the persons in charge to execute the necessary tasks, and who are able to recognize and avoid any possible danger. Such qualified personnel must also know and be able to provide first aid procedures if necessary. The entire start-up, maintenance and repair tasks must only be performed by qualified personnel.

2.2 SAFETY INSTRUCTIONS



DANGER

During normal operation of this equipment, a hazard associated with energized or rotating components with high voltage or elevated temperatures exists. Thus, the operation with open terminal boxes, unprotected couplings, improper handling, or failure to comply with the operating standards, may cause severe personal injuries and material damages.



ATTENTION

When devices and equipment are used outside the industrial environment, the user must ensure the safety of the equipment by adopting proper protection and safety measures during installation (for example, keeping people away, avoiding contact of children, etc.).

Those responsible for the safety of the installation must ensure that:

- Only qualified personnel install and operate the equipment;
- They have this manual and all other documents supplied with the motor at hand, as well as that they perform the tasks in strict compliance with the service instructions, relevant standards and specific product documentation.



ATTENTION

Failure to comply with installation and safety standards may void the product warranty. Firefighting equipment and first aid notices must be available in visible and easily accessible locations at the work site.

Qualified personnel must also observe:

- All the technical data regarding the allowed applications (operating conditions, connections and installation environment), provided in the purchase order documents, operating instructions, manuals and other documentation;
- The specific regulations and conditions for the local installation;
- The use of suitable tools and equipment for handling and transportation;
- That the protective devices of the individual components are removed shortly before installation. Individual parts must be stored in vibration-free environments, avoiding falls and ensuring their protection against aggressive agents and/or that they do not jeopardize people.

2.3 STANDARDS

Motors are specified, designed, manufactured and tested according to the standards described in Table 2.1. The applicable standards are specified in the commercial contract, which may indicate other national or international standards, depending on the application or installation location.

Table 2.1: Applicable standards

	STANDARDS
Specification	IEC60034-1 / NBR5117 IEC60034-3
Dimensions	IEC60072 / NBR5432
Tests	IEC60034-4 / NBR5052
Degrees of protection	IEC60034-5 / NBR IEC 60034-5
Cooling	IEC60034-6 / NBR IEC 60034-6
Mounting	IEC60034-7 / NBR IEC 60034-7
Noise	IEC60034-9 / NBR IEC 60034-9
Mechanical vibration	IEC60034-14 / NBR IEC 60034-14
Mechanical tolerances	ISO286 / NBR6158
Balancing	ISO1940 / NBR8008

2.4 ENVIRONMENTAL CONDITIONS

The motor was designed according to the specific environment characteristics (temperature and altitude) of your application, and are described on the nameplate and in the datasheet of the motor.



ATTENTION

For the use of water-cooled motors in ambient temperatures below +5 °C, antifreeze additives must be added to the water.

2.5 OPERATING CONDITIONS

In order for the product warranty to be valid, the motor must operate according to the rated data indicated on its nameplate, observing the applicable standards and the information provided in this manual.

2.6 VOLTAGE AND FREQUENCY

The motor must be able to perform its main function continuously in Zone A, but it does not have to fully meet its performance characteristics at rated voltage and frequency (refer to the point with rated characteristics in Figure 2.1), and it may present some deviations. The temperature rises may be above those at rated voltage and frequency.

The motor must be able to perform its main function in Zone B, but it may present greater deviations of its performance at rated voltage and frequency than in Zone A. The temperature rises may be higher than those observed at rated voltage and frequency and, most likely, will be higher than those in Zone A. Prolonged operation in the periphery of Zone B is not recommended.

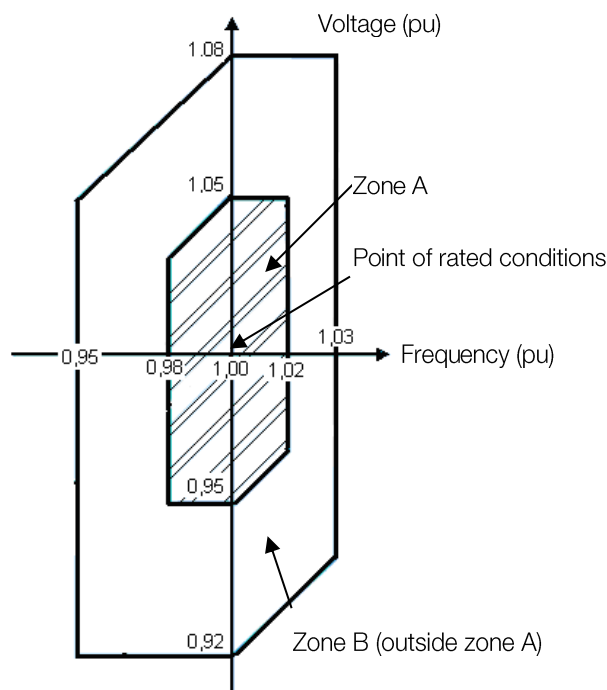

Figure 2.1: Voltage and frequency variation limits (IEC60034-1)

3 RECEIVING, STORAGE AND HANDLING

3.1 RECEIVING

All motors were tested and are in perfect operating conditions. The machined surfaces are protected against corrosion. The package must be inspected upon receipt for occasional damages during transportation.



ATTENTION

Any damage must be photographed, documented and reported immediately to the carrier, the insurer and WEG. The non-communication of this damage will void the warranty.



ATTENTION

Parts supplied in additional packages must be checked upon receipt.

- When lifting the package (or container), the proper hoisting points, the weight indicated on the package or on the nameplate, and the operating capacity of the hoisting equipment must be observed.
- Motors packed in wooden crates must always be lifted by their own hoisting eye or by a proper forklift; they must never be lifted by the package;
- The package can never be overturned. Place it on the floor carefully (without impact) in order to avoid damage to the bearings;
- Do not remove the grease for protection against corrosion from the shaft end and, or the closing plugs present in the terminal box holes. These protections must remain in place until the moment of the final assembly.
- A complete visual inspection of the motor must be carried out after removing the package;
- The shaft locking system must be removed just before the installation and stored to be used in future transportation of the motor.

3.2 HANDLING

- The handling of vertical motors must be performed as shown in Figure 3.1.
- Always use upper motor eyes/lifting lugs. for vertical movement, so that the lifting chains and cables are also in the vertical position, avoiding excessive strain on the eyes/lifting lugs.
- The sole purpose of the housing eyebolts/lifting lugs is to lift the motor. Never use them to lift active motor-machine sets.

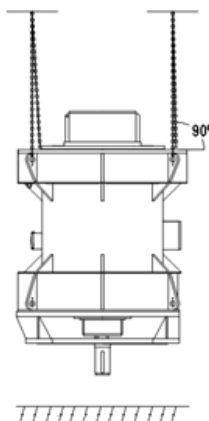

Figure 3.1: Handling motors



NOTES

- Observe the indicated weight. Do not lift the motor causing jolts or put it down abruptly on the floor, because this can cause damage to the bearings;
- In order to lift the motor, use only the lifting lugs provided for that purpose only. If necessary, use a crossbeam to protect parts of the motor;
- The lifting lugs on the heat exchanger, end shields, bearings, radiator, terminal box, etc. are designed to handle these components only separately;
- Never use the shaft to lift the motor;
- In order to move the motor, the shaft must be locked with the shaft locking device supplied with the motor.



ATTENTION

- Steel wire ropes, clevises and the lifting equipment must be able to stand the motor weight.
- For handling and assembling motors supplied disassembled, refer to the handling and assembly manual supplied with the motor.

3.2.1 Motor Positioning

Vertical motors are supplied with rear-end and front-end eyebolts/lifting lugs.

Some motors are transported horizontally and need to be moved back to their original position. The following procedure illustrates how motors are moved from horizontal to vertical position and vice-versa.

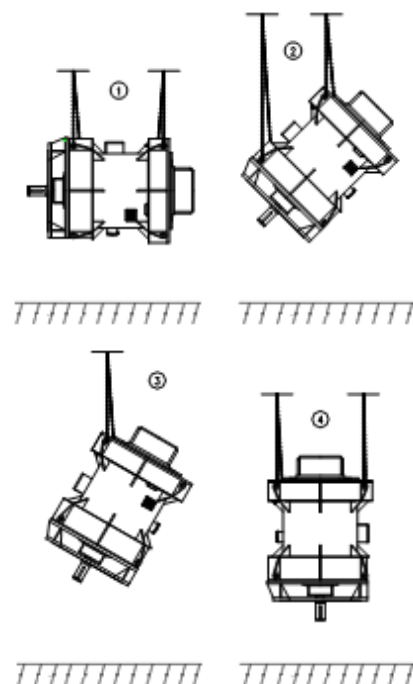

Figure 3.2: Motor positioning

1. Lift motor by the side eyes/lifting lugs using 2 hoists;
2. Lower the front-end of the motor and lift the rear-end until the motor is balanced;
3. Release the front-end cables and turn the motor 180° in order to fasten the cables in the remaining eyes/lifting lugs. located in the motor rear end;
4. Fasten loose cables to the eyes/lifting lugs on the rear end of the motor until the motor reaches a vertical position.



ATTENTION

Noncompliance with these recommendations may cause damage to the equipment, personnel injuries, or both.

3.3 STORAGE

If the motor is not installed immediately after reception, it must remain inside the package and stored in a location protected against moisture, vapors, sudden changes in temperature, rodents and insects.

The motor must be stored in vibration-free locations in order to avoid bearing damage.



ATTENTION

Space heaters must remain powered during storage in order to avoid water condensation inside the motor.
Any damage to the paint or corrosion protection of the machined parts must be repaired.

3.3.1 Indoor storage

If the motor is not installed immediately after reception, it must remain inside the package and stored in a location protected against humidity, vapors, fast heat variations, rodents, and insects.

The motor must be stored in vibration-free locations in order to avoid bearing damage.

3.3.2 Outdoor storage

The motor must be stored in a dry location, free of flooding and vibrations.

Repair all damages occasionally caused to the packing during transportation before storing the motor, which is necessary to ensure proper storage conditions.

Place the motor on platforms or foundations which ensure protection against humidity from the ground and prevent it from sinking into the soil. Free air circulation underneath the motor must be assured.

The cover used to protect the motor against the bad weather must not be in contact with its surfaces. In order to ensure free air circulation between the motor and such covers, place wooden blocks as spacers.

3.3.3 Extended storage

When the motor is stored for a long period (two months or more) before the start-up, it is exposed to external agents, such as temperature variations, moisture, aggressive agents, etc.

Empty spaces inside the motor, such as those in bearings, terminal box, and windings, are exposed to humidity, which may condense and, depending on the type and degree of air contamination, aggressive substances may also penetrate these empty spaces.

Consequently, after long periods of storage, the winding insulation resistance may drop below the acceptable values, internal components, such as bearings, may oxidize, and the lubricant power of the lubricant agent in the bearings may be adversely affected.

All of these influences increase the risk of damages before the motor start-up.



ATTENTION

For the motor warranty to be valid, it is necessary to make sure that all the preventive measures described in this manual, as well as constructive aspects, maintenance, packing, storage and periodical inspections be followed and recorded.

The extended storage instructions are valid for motors that remain stored for long periods (two months or more) before start-up or motors already installed and that are in a prolonged stoppage, considering the same period.

3.3.3.1 Storage location

In order to ensure the best storage conditions for the motor during long periods of time, the chosen location must strictly meet the criteria described below.

3.3.3.1.1 Indoor storage

- The storage site must be closed and covered;
- The site must be protected against moisture, vapors, aggressive agents, rodents and insects;
- Corrosive gases, such as chlorine, sulfur dioxide or acids, must not be present;
- The site must be free of vibration;
- The site must have a ventilation system with air filter;
- Ambient temperature between 5°C and 60°C, without sudden temperature variations;
- Relative humidity <50%;
- The site must be protected against dirt and dust accumulation;
- It must have a fire detection system;
- The location must have a power supply for the space heaters.

If any of these requirements is not met in the storage site, WEG recommends that additional protections be incorporated to the motor package during the storage period, as follows:

- A closed wooden crate or the like with an electrical installation that allows the energization of the space heaters;
- If there is risk of infestation and fungus formation, the package must be protected in the storage location by spraying it or painting it with appropriate chemicals;
- The package must be prepared carefully by an experienced person.

3.3.3.1.2 Outdoor storage



ATTENTION

Outdoor storage of the motor is not recommended.

In case outdoor storage is unavoidable, the motor must be packed in a specific package for such condition, as follows:

- For outdoor storage (exposed to the weather), besides the package recommended for indoor storage, the package must be covered with protection against dust,

moisture and other foreign materials, using resistant canvas or plastic.

- The package must be placed on platforms or foundations that ensure protection against dirt and moisture and keep it from sinking into the soil;
- After the package is covered, a shelter must be erected to protect it against direct rain, snow and excessive sun heat.



ATTENTION

In case the motor remains stored for long periods (two months or more), it is recommended to inspect it regularly as specified in the section 3.3.3.11 of this manual.

3.3.3.2 Separate parts

- In case separate parts have been supplied (terminal boxes, covers, etc.), these must be packed as specified in items Indoor Storage and Outdoor Storage of this manual;
- Air relative humidity inside package must not exceed 50%.
- Rolling bearings must not be subject to shocks, falls or storage with vibration or humidity, which can cause marks on the internal races or on the balls, reducing their useful life.

3.3.3.3 Space heater



ATTENTION

The space heaters must remain powered during storage to avoid moisture condensation inside the motor and ensure that the winding insulation resistance remains within acceptable levels.

3.3.3.4 Insulation resistance

During the storage period, the insulation resistance of the motor windings must be measured and recorded every three months and before the motor installation. Any insulation resistance reduction must be investigated.

3.3.3.5 Exposed machined surfaces

All exposed machined surfaces (e.g., shaft end and flanges) are protected at the factory with a temporary protective agent (rust inhibitor).

This protection coating must be reapplied every six months or when removed and/or damaged.

Recommended Product: Anticorit BW protective agent

Manufacturer: Fuchs

3.3.3.6 Sleeve bearing

Depending on the machine mounting position and the lubrication type, the machine can be transported with or without oil in the bearings.

The machine storage must be done in its original operating position and with oil in the bearings, when so specified.

The oil level must be respected, remaining in the middle of the sight glass.

In order to keep the bearings in good conditions during the storage period, the following preservation procedures must be performed:

- Close all the threaded holes with plugs;

- Check if all the flanges (e.g., oil inlet and outlet) are closed. If not, they must be closed with blind covers;
- The oil level must be respected, remaining in the middle of the oil sight glass;
- Every two months the shaft locking device should be removed the shaft, add between 100 and 200ml of lubricating oil through the sight glass at the top of the bearing and rotate the shaft which can be done manually with the help of a lever, two or three complete turns are sufficient.



NOTES

For bearings that have a high-pressure oil injection system (jacking), this system must be activated before rotating the machine rotor. For bearings without an internal oil reservoir (dry sump) and for thrust and counter-bearings, the oil circulation system must be activated to turn the machine shaft. The shaft rotation must always be done in the machine rotation direction.

If it is not possible to rotate the machine shaft, as recommended, after six months of storage, the following procedure must be used for protecting both the bearing internally and the contact surfaces against corrosion:

- Close all the threaded holes with plugs;
- Seal the gaps between the shaft and the bearing seal on the shaft by applying water-proof adhesive tape;
- Check if all the flanges (e.g., oil inlet and outlet) are closed. If not, they must be closed with blind covers;
- Remove the upper sight glass from the bearing and apply the corrosion inhibitor spray (TECTYL 511 or equivalent) inside the bearing;
- Close the bearing with the upper sight glass.



NOTES

If the bearing has no upper sight glass, the top cover of the bearing must be disassembled to apply the corrosion inhibitor spray.

Each six months of storage, repeat the procedure described above.

If the storage period exceeds two years.

- Disassemble the bearing;
- Preserve and store the parts.

3.3.3.7 Terminal box

When the insulation resistance of the motor windings is measured, the main terminal box and the other terminal boxes must also be inspected, observing the following aspects:

- The inside must be dry, clean and free of dust accumulation;
- The contact elements cannot present corrosion;
- The seals must be in proper condition;
- The cable inlets must be correctly sealed.



ATTENTION

If any of these items are not in proper condition, proceeds the adequate maintenance and, if necessary, replace damaged parts.

3.3.3.8 Radiator

When the radiator remains out of operation for a long period, it must be drained and dried. The drying may be done with pre-heated compressed air. During the winter, in case there is risk of freezing, all the water must be drained from the radiator, even if the motor remains out of operation just for a short period in order to prevent deformation of the pipes or damages to the seals.



NOTE

During short operation stoppages, instead of draining the water, it is preferable to keep its circulation at low speeds through the heat exchanger, thus ensuring that harmful products, such as ammonia compounds and hydrogen sulfide, are taken out of the radiator and not deposited inside.

3.3.3.9 Inspections and records during storage

The stored motor must be inspected periodically and inspection records must be filed.

The following points must be inspected:

1. Physical damages;
2. Cleanliness;
3. Signs of water condensation;
4. Protective coating conditions;
5. Paint conditions;
6. Signs of aggressive agents;
7. Satisfactory operation of space heaters. It is recommended that a signaling or alarm system be installed in the location in order to detect power interruption on the space heaters;
8. Record the ambient temperature and relative humidity around the motor, the winding temperature (using RTDs), the insulation resistance and the polarization index;
9. The storage location must also be inspected to assert its compliance with the criteria described in the item Storage location.

3.3.3.10 Preparation for commissioning

3.3.3.10.1 Cleaning

- Motor inner and outer parts must be free of oil, water, dust, and dirt.
- Remove the rust inhibitor from the exposed surfaces with a cloth damped in a petroleum-based solvent;
- Make sure the bearings and cavities used for lubrication are free of dirt and the cavity plugs are correctly sealed and tightened. Oxidation and marks on bearing seats and on the shaft must be carefully removed.

3.3.3.10.2 Bearing lubrication

Only use the specified lubricant to lubricate the bearings. Information on bearings and lubricants are indicated on the bearing nameplate, and lubrication must be performed as described in the item Bearing maintenance of this manual, always considering the relevant type of bearing.

3.3.3.10.3 Checking the insulation resistance

Before operating the motor, the insulation resistance must be measured according to the item Insulation resistance of this manual.

3.3.3.10.4 Others

Follow the other procedures described in the item Commissioning of this manual before operating the motor.

3.3.3.11 Maintenance plan during storage

During the storage period, the motor maintenance must be performed and recorded according to the plan described in Table 3.1.

Table 3.1: Storage plan

	Monthly	2 months	6 months	2 years	Before start-up	NOTES
Storage Location						
Inspect the cleanliness conditions		x			x	
Inspect the humidity and temperature conditions		x				
Check for signs of insect infestation		x				
Package						
Inspect for damages			x			
Check the internal relative humidity		x				
Change the dehumidifier in the package (if any)			x			Whenever necessary
Space heater						
Check the operating conditions	x					
Whole motor						
Perform external cleaning			x		x	
Check the painting conditions			x			
Check the rust inhibitor on the exposed machined parts			x			
Reapply the rust inhibitor			x			
Windings						
Measure the insulation resistance		x			x	
Measure the polarization index		x			x	
Terminal box and grounding terminals						
Clean the interior of the boxes				x	x	
Inspect the seals and gaskets				x	x	
Grease or oil-lubricated rolling bearing						
Rotate the shaft		x				
Relubricate the bearing			x		x	
Disassemble and clean the bearing						If the storage period exceeds 2 years
Sleeve bearings						
Rotate the shaft		x				
Apply anti-corrosive spray			x			
Clean the bearings and relubricate them					x	
Disassemble and store the parts						If the storage period exceeds 2 years
Brushes						
Lift the brushes						During storage
Lower the brushes and check the contact with the slip rings					x	

3.3.4 Preparation for commissioning

3.3.4.1 Cleaning

- The internal and external parts of the motor must be free of oil, water, dust, and dirt.
- Remove the rust inhibitor from the exposed surfaces with a cloth dampened in a petroleum-based solvent;
- Make sure that the bearings and cavities used for lubrication are free of dirt and the cavity plugs are correctly sealed and tightened. Oxidation and marks on the bearing seats and on the shaft must be carefully removed.

3.3.4.2 Bearing inspection



ATTENTION

If the motor storage period exceeds six months, the sleeve bearings must be disassembled, inspected and cleaned, before starting the motor operation. The sleeve bearings without oil tank (dry crankcase), regardless of the motor storage period, should necessarily be disassembled, inspected and cleaned before starting the motor operation. Reassemble the sleeve bearings and carry out lubrication. Contact WEG to perform this procedure.

3.3.4.3 Bearing lubrication

Use the lubricant specified for bearing lubrication. Information on the bearings and lubricants are indicated on the bearing nameplate, and the lubrication must be done as described in section 7.12 of this manual, always considering the type of bearing.

3.3.4.4 Brushes, brush holders and slip rings

- Check the conservation conditions of the brush holder and slip rings;
- Check the connection of the brushes and that they are not stuck in the brush holder. They must be in their original position and establish perfect contact with the slip rings.

3.3.4.5 Insulation resistance verification

Before putting the motor into operation, the insulation resistance must be measured according to section 3.3.3.4 of this manual.

3.3.4.6 Air-water heat exchanger

- When starting the motor, ensure that the water circulates freely through the radiator;
- The radiator bolts should be tightened with torques of 40 to 50Nm;
- Make sure that there is no water leakage. Check the radiator gaskets, and replace if necessary;
- Check the heat exchanger sealing rubbers and replace them if necessary.

3.3.4.7 Others

Follow the other procedures described in section 6 of this manual before putting the motor into operation.

4 INSTALLATION

4.1 INSTALLATION SITE

Motors must be installed in easily accessible places, allowing periodic inspections, on-site maintenance and, if necessary, removal for external services.

The following environmental conditions must be ensured:

- Clean and well-ventilated location;
- The installation of other equipment or walls must not hinder or block the motor ventilation;
- The area around and above the motor must be sufficient for maintenance or handling;
- The environment must be in accordance with the motor protection degree.

4.2 SHAFT LOCK

The motor leaves the factory with a lock on the shaft to prevent damages to the bearings during transportation. This lock must be removed prior to motor installation.



ATTENTION

The shaft locking device must be installed whenever the motor is removed from its base (uncoupled) in order to prevent damages to the bearings during transportation.

The shaft end is protected at the factory with a temporary protective agent (rust inhibitor). During the motor installation, it is necessary to remove this product from the grounding brush (if any) contact track on the shaft.

4.3 DIRECTION OF ROTATION

The rotation direction is indicated on a plate affixed to the drive end of the motor and in the motor specific documentation.



ATTENTION

Motors supplied with a single rotation direction must not operate in the opposite direction.

In order to operate the motor in the opposite direction, consult WEG.

4.4 INSULATION RESISTANCE

4.4.1 Safety instructions



DANGER

In order to measure the insulation resistance, the motor must be turned off and stopped.

The winding being tested must be connected to the frame and grounded until all residual electrostatic charges are removed. Capacitors (if any) must also be grounded before disconnecting and separating the terminals to measure the insulation resistance. Failure to comply with these procedures may result in personal injury.

4.4.2 General considerations

When the motor is not immediately put into operation, it must be protected against moisture, high temperatures, and dirt, avoiding impacts to the insulation resistance.

The winding insulation resistance must be measured before putting the motor into operation.

If the environment is too humid, the insulation resistance must be measured periodically during storage. It is difficult to establish fixed rules for the actual value of the winding insulation resistance, as it varies according to the environmental conditions (temperature, humidity), motor cleanliness conditions (dust, oil, grease, dirt), and quality and condition of the insulating material used.

The evaluation of the periodical follow-up records is useful to conclude whether the motor is able to operate.

4.4.3 Stator winding measuring

The insulation resistance must be measured with a megohmmeter. The testing voltage for the windings must be in accordance with Table 4.1, and according to IEEE43 standard.

Table 4.1: Voltage for the winding Insulation resistance test

*Winding rated voltage (V)	Insulation resistance test - continuous voltage (V)
< 1000	500
1000 - 2500	500 - 1000
2501 - 5000	1000 - 2500
5001 - 12000	2500 - 5000
> 12000	5000 - 10000

* Phase-phase rated voltage

Before measuring the stator winding insulation resistance:

- Disconnect all connections to the stator terminals;
- Disconnect and insulate all CTs and PTs (if any);
- Ground the motor frame;
- Measure the winding temperature;
- Ground all temperature sensors;
- Check the humidity;
- Disconnect the neutral grounding;
- Ensure that the motor bars are not grounded.

The insulation resistance measurement of the stator windings must be done in the main terminal box.

The instrument (megohmmeter) must be connected between the motor frame and the winding. The frame must be grounded and the three phases of the stator winding must remain connected to the neutral point, as shown in

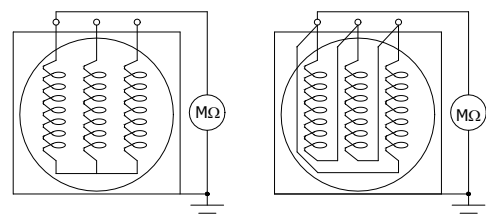

Figure 4.1: Megohmmeter connection

Whenever possible, each phase must be isolated and tested separately. The separate test allows a comparison between the phases. When a phase is tested, the other two phases must be grounded to the same ground of the frame, as shown in Figure 4.2.

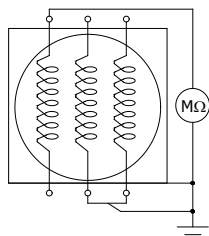

Figure 4.2: Connection of the megohmmeter to separate phases

If the total winding measurement presents a value below the recommended, the neutral connections must be opened and the insulation resistance of each phase must be measured separately.



ATTENTION

Much higher values may be frequently obtained in motors being operated for a long period of time. Comparison with values obtained in previous tests on the same motor - under similar load, temperature and humidity conditions - may be an excellent parameter to evaluate the winding insulation conditions, instead of using the value obtained in a single test as the basis. Significant or sudden reductions are considered suspicious.

Table 4.2: Insulation resistance referential limits in electric machines

Insulation resistance value	Insulation evaluation
2 MΩ or less	Unacceptable
< 50 MΩ	Dangerous
50...100 MΩ	Regular
100...500 MΩ	Good
500...1000 MΩ	Very Good
> 1000 MΩ	Excellent

4.4.4 Measurement on the rotor winding

In order to measure the rotor insulation resistance, the field windings must be isolated from the control. That can be accomplished by lifting the brushes from the slip rings or by disconnecting the field control cables from the brush holders;

- The measurement of the rotor winding insulation resistance must be carried out in the brushes compartment;
- The instrument (megohmmeter) must be connected between the motor shaft and the slip rings;
- The measuring current must not flow through the bearings;
- Measure and record the winding temperature.

Measurement on the rotor winding:

- Disconnect the rotor cables from the diode cluster and from the load resistor (when applicable);
- Connect the device to measure the insulation resistance (megohmmeter) between the rotor winding and the motor shaft. The measuring current must not pass through the bearings.

Measurement of the main exciter stator winding

- Disconnect the exciter power cables;
- Connect the device to measure the insulation resistance (megohmmeter) between the exciter stator winding (terminals F+ and F-) and the motor frame.

Measurement on the main exciter rotor winding:

- Disconnect the exciter rotor cables from the diode cluster;

- Connect the device to measure the insulation resistance (megohmmeter) between the exciter rotor winding and the motor shaft. The measuring current must not pass through the bearings.



ATTENTION

After measuring the insulation resistance, ground the tested winding in order to discharge it.

The test voltage to measure the insulation resistance of the rotor and space heater must be 500 Vdc and for the other accessories 100 Vdc.

It is not recommended to measure the insulation resistance of thermal protectors.

4.4.5 Polarization index

The polarization index is defined by the ratio between the insulation resistance measured in 10 minutes and the insulation resistance measured in 1 minute. This measurement procedure is always carried out at relatively constant temperatures. The polarization index allows the evaluation of the motor insulation conditions.

Table 4.3: Polarization index (relation between 10 minutes and 1 minute)

Polarization index	Insulation evaluation
1 or less	Unacceptable
< 1.5	Dangerous
1.5 to 2.0	Regular
2.0 to 3.0	Good
3.0 to 4.0	Very Good
> 4.0	Excellent



DANGER

In order to prevent accidents, the motor winding must be grounded immediately after measuring the insulation resistance.

4.4.6 Conversion of the measured values

The insulation resistance measured on the windings shall be converted to 40 ° C using the correction factor provided in Figure 4.3 (IEEE43 standard) and applying the following formula:

$$R_c = K_t \cdot R_t$$

Where:

R40 = referred insulation resistance at 40 ° C

Kt = Insulation resistance correction factor as a function of temperature, as shown in Figure 4.3,

Rt = measured insulation resistance.

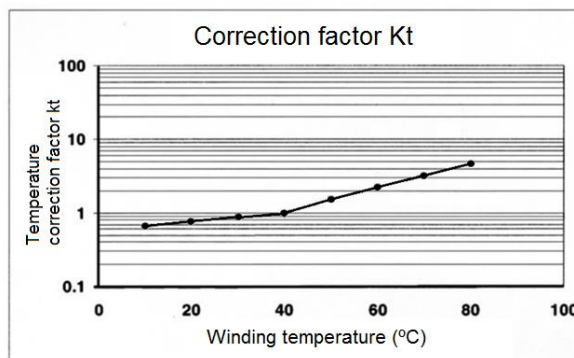

Figure 4.3: Insulation resistance correction factor due to temperature

The values used to generate the curve of Figure 4.3 are shown in Table 4.4.

Table 4.4: Correction factors (Kt) due to temperature

t (°C)	Correction factor kt
10	0,7
20	0,8
30	0,9
40	1,0
50	1,5
60	2,3
70	3,3
80	4,6

4.4.7 Recommended Minimum Values

According to IEEE-43 Standard, the recommended minimum values for winding insulation resistance (R.I.) and Polarization Index (I.P.) are shown in Table 4.3:

Table 4.5: Minimum R.I. e I.P values

Winding voltage	Minimum R.I. (converted to 40°C)	Minimum I.P.
Up to 1000 V	5 MΩ	Not applicable
Greater than 1000 V	100 MΩ	2

4.5 PROTECTIONS

Motors used in continuous duty must be protected against overloads by means of a motor integral device, generally a thermal relay with rated or adjustable current equal to or below the value obtained by multiplying the rated current of the motor at full load by:

- 1.25 for motors with service factor equal to or above 1.15;
- 1.15 for motors with service factor equal to 1.0.

Motors also have temperature sensors to be used as protection devices against excessive temperature rise (in case of overloads, lack of motor ventilation).

4.5.1 Thermal protections

The temperature sensors are installed on the main stator, bearings and other parts that require temperature monitoring and thermal protection. The terminals of the temperature sensors are available in the accessory box.

These sensors must be connected to an external temperature monitoring and protection system.

4.5.1.1 Temperature sensors

Thermostats – Are bimetallic thermal detectors with normally closed silver contacts. They open at a certain temperature. The thermostats are connected in series or independently according to the connection diagram.

Thermistors (PTC or NTC) - Are thermal detectors composed of semiconductors that vary their resistance sharply when they reach a certain temperature. Thermistors are connected in series or independently according to the connection diagram.



NOTE

Thermostats and thermistors must be connected to a control unit in order to interrupt the motor operation or activate a signaling device.

RTDs (Pt100) - Are calibrated resistance elements. Their operation is based on the principle that the electrical resistance of a metallic conductor varies linearly with the temperature. The detector terminals must be connected to a control panel which includes a temperature meter.



NOTE

Resistance temperature detectors (RTD) allow the monitoring via the absolute temperature informed through their instantaneous resistance value. With this information the relay, which can be programmed for alarm and trip according to pre-defined values, is able to perform the temperature reading.

4.5.1.2 Temperature limits for the windings

The temperature of the hottest spot of the winding must be kept below the limit of the insulation thermal class.

The total temperature is obtained by the sum of the ambient temperature and the temperature rise (T), plus the difference between the average temperature of the winding and the hottest spot of the winding.

The ambient temperature must not exceed 40 °C, in accordance with NBR IEC60034-1 standard. Above this temperature, the working conditions are considered special and the motor specific documentation must be consulted.

Table 4.6 shows the numerical values and the composition of the acceptable temperature of the hottest spot on the winding.

Table 4.6: Insulation class

Insulation class (°C)	F	h
Ambient temperature	40	40
T = temperature rise (temperature measurement method by resistance variation)	105	125
Difference between the hottest point and the average temperature	10	15
Total: temperature of the hottest point	155	180



ATTENTION

If the motor operates with temperatures in the windings above the limit values of the insulation thermal class, the lifespan of the insulation and, consequently, of the motor, will be significantly reduced, or it may even result in the motor burnout.

4.5.1.3 Alarm and trip temperatures

The motor alarm and trip temperatures must be set at the lowest possible value. These temperatures can be determined based on the factory tests or through the motor operating temperature.

The alarm temperature can be set 10 °C above the machine operating temperature at full load, always considering the highest ambient temperature on site.

**ATTENTION**

The alarm and trip values may be determined as a result of experience, but they must not exceed the values indicated in the motor wiring diagram.

**ATTENTION**

The motor protection devices are listed in the WEG drawing – Wiring diagram. Not using these devices is the sole responsibility of the user and, in case of damage to the motor, it will void the warranty.

4.5.1.4 Temperature and ohmic resistance of the PT100 thermoresistance

Table 4.7 shows the temperature as a function of the ohmic resistance measured across PT100 RTDs.

Formula: $\frac{\Omega - 100}{0,386} = \text{°C}$

Table 4.7: Temperature X Resistance (Pt100)

°C	0	1	2	3	4	5	6	7	8	9
0	100.00	100.39	100.78	101.17	101.56	101.95	102.34	102.73	103.12	103.51
10	103.90	104.29	104.68	105.07	105.46	105.95	106.24	106.63	107.02	107.40
20	107.79	108.18	108.57	108.96	109.35	109.73	110.12	110.51	110.90	111.28
30	111.67	112.06	112.45	112.83	113.22	113.61	113.99	114.38	114.77	115.15
40	115.54	115.93	116.31	116.70	117.08	117.47	117.85	118.24	118.62	119.01
50	119.40	119.78	120.16	120.55	120.93	121.32	121.70	122.09	122.47	122.86
60	123.24	123.62	124.01	124.39	124.77	125.16	125.54	125.92	126.31	126.69
70	127.07	127.45	127.84	128.22	128.60	128.98	129.37	129.75	130.13	130.51
80	130.89	131.27	131.66	132.04	132.42	132.80	133.18	133.56	133.94	134.32
90	134.70	135.08	135.46	135.84	136.22	136.60	136.98	137.36	137.74	138.12
100	138.50	138.88	139.26	139.64	140.02	140.39	140.77	141.15	141.53	141.91
110	142.29	142.66	143.04	143.42	143.80	144.17	144.55	144.93	145.31	145.68
120	146.06	146.44	146.81	147.19	147.57	147.94	148.32	148.70	149.07	149.45
130	149.82	150.20	150.57	150.95	151.33	151.70	152.08	152.45	152.83	153.20
140	153.58	153.95	154.32	154.70	155.07	155.45	155.82	156.19	156.57	156.94
150	157.31	157.69	158.06	158.43	158.81	159.18	159.55	159.93	160.30	160.67

4.5.2 Space heater

When the motor is equipped with a space heater to prevent internal water condensation during long periods out of operation, it must be assured that the space heater is energized shortly after turning the motor off, and that it is de-energized before the motor is put into operation. The values of the space heater supply voltage and power are informed in the connection diagram and in the specific plate affixed to the motor.

4.5.3 Water leak sensor

Motors with air-water heat exchanger are supplied with a water leak sensor intended to detect water leaks from the radiator into the motor. This sensor must be connected to the control panel, according to the motor connection diagram. The signal of this sensor must be used to activate the alarm.

When this protection actuates, the heat exchanger must be inspected and, if any water leak is detected, the motor must be shut down and the problem corrected.

4.6 COOLING

The motor cooling system may vary according to its application.

Only the proper installation of the motor and of the cooling system can ensure its continuous operation without overheating.



ATTENTION

The protection devices of the cooling system must be monitored periodically; The air and/or water inlets and outlets must not be obstructed, because this could cause overheating and even lead to the motor burnout. For further details, refer to the motor dimensional drawing.

4.6.1 Water radiators

In motors with air-water heat exchangers, the internal air, in a closed circuit, is cooled by the radiator, which is a surface heat transmitter designed to dissipate heat. Clean water with the following characteristics must be used as coolant:

- pH: 6 to 9;
- Chlorides: maximum 25.0 mg/l;
- Sulphates: maximum 3.0 mg/l;
- Manganese: maximum 0.5 mg/l;
- Suspended solids: maximum 30.0 mg/l;
- Ammonia: no ammonia present.



ATTENTION

The data of the radiators that compose the air-water heat exchanger are described on the nameplate and dimension drawing of the motor. This data must be observed for the proper operation of the motor cooling system and, thus, prevent overheating.

4.6.1.1 Radiators for application with sea water



ATTENTION

In the case of radiators for applications with sea water, the materials in contact with the water (pipes and plates) must be corrosion resistant. Furthermore, the radiators may be fitted with sacrificial anodes (e.g., zinc or magnesium), as shown in Figure 4.1, which corrode during the heat exchanger operation, protecting the radiator heads. In order to maintain the integrity of the radiator heads, these anodes must be replaced periodically, according to their corrosion level.

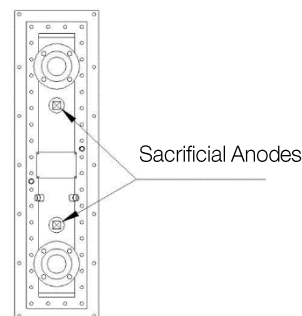

Figure 4.1: Radiator with sacrificial anodes



NOTE

The type, quantity and position of the sacrificial anodes may vary according to the application.

4.6.1.2 Independent ventilation cooling

The **independent fans** are driven by three-phase asynchronous motors, with integral terminal boxes. The characteristic data (frequency, voltage, etc.) are on the nameplate of these motors, and the rotation direction is indicated by a plate affixed to the fan housing or close to it.



NOTE

It is necessary to check the rotation direction of the independent ventilation motors before starting the motor. If the rotation direction is opposite to the specified, invert the connection of two of their power supply phases.

The **air filters** (if any) which prevent the ingress of dirt into the motor must be regularly inspected, according to the section "Maintenance Plan" of this manual. The filters must be in perfect condition to ensure the proper operation of the cooling system and the permanent protection of the motor sensitive internal parts.

4.6.1.3 Air/Air heat exchanger cleaning

Some fouling of the cooling surface and the tube wall will eventually occur. This fouling reduces the cooling capacity. The heat exchanger should therefore be cleaned at regular intervals, to be determined from case to case, depending of the properties of the cooling air. During the initial period of operation, the heat exchanger should be inspected frequently. Blow the heat exchanger clean with compressed air or clean it with a suitable brush. Do not use a steel brush in aluminum tubes as it can damage the tubes; a soft round brass wire brush can be used instead.

4.7 ELECTRICAL ASPECTS

4.7.1 Electric connections



ATTENTION

Analyze the electrical connection diagram supplied with the motor carefully before beginning the connection of the power, grounding and accessory cables. For the electrical connection of the auxiliary equipment, refer to their specific manuals.

4.7.1.1 Main electrical connection

The location of the power, neutral and rotor terminal boxes are identified in the specific dimensional drawing of each motor.

The stator and rotor terminal identifications and their corresponding connections are indicated in the specific motor connection diagram.

Make sure the cross section and insulation of the connection cables are suitable for the motor current and voltage.

The motor must rotate in the rotation direction specified on the nameplate and/or on the plate affixed to the drive end of the motor.



NOTE

The rotation direction is, by convention, determined looking to the shaft end at the motor drive end. Motors with a single rotation direction must only rotate in the indicated direction, since fans and other devices are unidirectional. In order to operate the motor in the rotation direction opposite to the specified, consult WEG.



ATTENTION

Before making the connections between the motor and the power line, it is necessary to perform a careful measurement of the winding insulation resistance.

In order to connect the motor main power cables, unscrew the stator terminal box cover, cut the sealing rings (standard motors without cable gland) according to the diameter of the cables to be used and insert the cables in the sealing rings. Cut the power cables to the necessary length, strip the ends and mount the cable lugs that will be used.

4.7.1.2 Grounding

The motor frame and the main terminal box must be grounded before connecting the motor to the power line. Connect the metal sheath of the cables (if any) to the common grounding conductor. Cut the grounding conductor to the proper length and connect it to the terminal in the terminal box and/or frame. Fasten all connections firmly.



ATTENTION

Do not use washers made of steel or other materials with low electrical conductivity to fasten the cable lugs.

4.7.1.3 Field power supply and control

The power supply and the control of the field must be connected and adjusted according to the connection diagram of the motor and the specific manual of the excitation panel.

4.7.2 Connection diagram

- The connection diagram of the stator, rotor and accessories is supplied together with the motor documentation.
- Figure 4.4 shows the single line connection diagram of a synchronous motor with brushes.

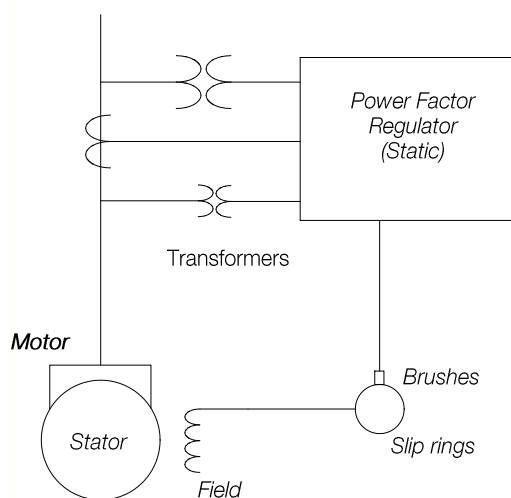

Figure 4.4: General connection diagram (brushless motor)

4.8 MECHANICAL ASPECTS

4.8.1 Foundations

- The foundation or structure where the motor will be installed must be sufficiently rigid, flat, free of external vibration and capable to withstand the mechanical loads to which it will be submitted;
- If the foundation dimensioning is not carefully executed, this may cause serious vibration on the foundation set, motor and turbine;
- The foundation structural design must be done based on the dimensional drawing, on the information about the foundation mechanical loads, and on the motor anchoring method.
- The customer is responsible for the design and construction of the foundation according to the requirements described in section 4.8.5.



ATTENTION

Use shims of different thicknesses (total thickness of approximately 2 mm) between the motor feet and the foundation surfaces so that later you can make a precise vertical alignment.



NOTE

The user is responsible for dimensioning and building the foundation where the motor will be installed.

4.8.2 Foundations loads

The foundation loads are informed in the motor documentation.

4.8.3 Metal base

The motor feet must be settled evenly on the metal base so as to prevent deformations of the frame. Occasional height errors of the motor foot rest surface can be corrected with shims (a maximum height of 2 mm is recommended). Do not remove the machines from the common base to align them. The base must be leveled on the foundation itself by using leveling devices. When a metal base is used to adjust the height of the motor shaft end to the driving machine shaft end, it must be leveled on the concrete base. After the base is leveled, the anchors tightened and the couplings checked, the metal base and the anchors are cemented.

4.8.4 Motor mounting



ATTENTION

Mount the motor in a safe way and align it properly. The inadequate mounting can generate excessive vibration, causing early wear of the bearings and even break the shaft.

4.8.5 Natural frequency of the base

In order to ensure a safe operation, the motor must be precisely aligned with the coupled equipment and both must be properly balanced. As a requirement, the motor installation base must be flat and meet the requirements of DIN standard 4024-1. In order to check if the criteria of the standard are being met, the following potential frequencies of vibration excitation generated by the motor and coupled machine must be checked:

- The motor rotation frequency;
- The double of the rotation frequency;
- The double of the electric frequency of the motor supply.

According to DIN standard 4024-1, the natural frequencies of the base or foundation must keep a distance from these potential frequencies of excitation, as specified below:

- The first natural frequency of the base or foundation (natural frequency of first order of the base) must be out of the range from 0.8 to 1.25 times any of the potential frequencies of excitation above;
- The other natural frequencies of the base or foundation must be out of the range from 0.9 to 1.1 times any of the potential frequencies of excitation above.

4.8.6 Alignment of the motor with the driven machine

The motor must be perfectly aligned with the driving machine, especially when direct coupling is used. The alignment must be carried out according to the directions of the coupling manufacturer. The alignment must be performed observing the maximum acceptable values. Especially in direct couplings, the motor and driven machine shafts must be aligned in the axial and radial directions, as shown in Figure4.5 and Figure4.6.

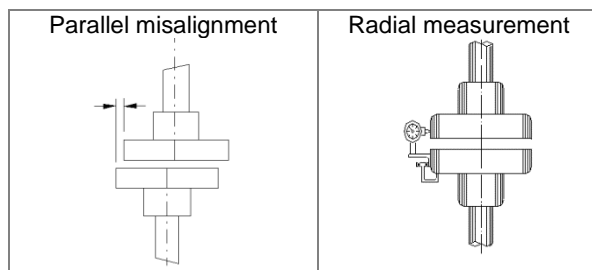

Figure4.5: Parallel alignment

Figure4.5 shows the parallel misalignment of the two shaft ends and a practical form to measure it by using proper dial gauges. Measurement is performed in four points with a 90° displacement from each other and with the two half-couplings spinning together in order to eliminate the effects of irregularities on the support surface on the tip of the dial gauge. Choosing a vertical point greater than 0°, half the difference of the dial gauge measurement in the 0° and 180° points represents the vertical coaxial error. In case of deviation, it must be properly corrected, adding or removing assembly shims. Half the difference of the dial gauge measurement in the 90° and 270° points represents the horizontal coaxial error. This measurement indicates when it is necessary to lift or lower the motor, or move it to the right or to the left on the driven side in order to eliminate the coaxial failure. Half the difference of the dial indicator maximum measurement in a complete turn represents the maximum found run out. The misalignment in a complete turn of the shaft cannot exceed 0.03 mm. When flexible couplings are used, values that are greater than those indicated above are acceptable, provided that they do not exceed the acceptable value provided by the coupling manufacturer. Maintaining a safety margin for these values is recommended.

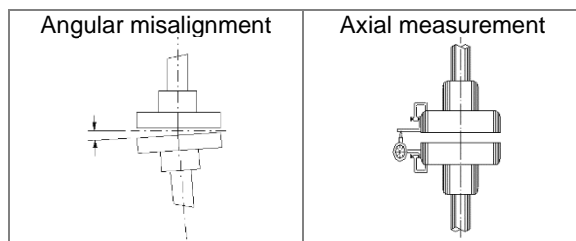

Figure4.6: Angular alignment

Figure4.6 shows the angular misalignment and a practical form to measure it. Measurement is performed in four points with a 90° displacement from each other and with the two half-couplings spinning together in order to eliminate the effects of irregularities on the support surface on the tip of the dial gauge. Choosing a vertical point greater than

0°, half the difference of the dial indicator measurement in the 0° and 180° points represents a vertical misalignment. In case of deviation, it must be properly corrected, adding or removing assembly shims from the motor feet.

Half of the dial indicator measurement difference in the 90° and 270° points represents a horizontal misalignment, which must be adequately corrected by displacing the motor in the lateral/angular direction.

Half the difference of the dial indicator maximum measurement in a complete turn represents the maximum angular misalignment found.

The misalignment in a complete turn of the rigid or semi-flexible coupling cannot exceed 0.03 mm.

When flexible couplings are used, values that are greater than those indicated above are acceptable, provided that they do not exceed the acceptable value provided by the coupling manufacturer.

Maintaining a safety margin for these values is recommended.

In the alignment/leveling, the influence of temperature on the motor and driven machine must be taken into account. Different dilatations of the component parts may change the alignment/leveling conditions during operation.

4.8.7 Couplings

Only proper couplings, which convey only torque without generating transversal forces, must be used. For both flexible and rigid couplings, the shaft centers of the coupled machines must be in a single line. Flexible couplings mitigate the effects of residual misalignments and prevent transmission of vibration between the coupled machines, which does not occur when rigid couplings are used.

The coupling must be mounted or removed with the aid of proper devices and never by means of rudimentary tools, such as hammers, sledgehammers, etc.

Follow the manufacturer's instructions when mounting or removing couplings or other drive elements and cover them with a touch guard. For trial run in uncoupled state, lock or remove the shaft end key.

Avoid excessive radial and axial bearing loads (note manufacture's documentation). The balance of the machine is indicated as H= half and F= full key. In half key cases coupling must be half key balanced without a key. In case of protruding, visible part of the shaft end key, establish mechanical balance.



ATTENTION

Dowel pins, nuts, washers and leveling shims may be supplied with the motor when requested in the purchase order.



NOTES

The user is responsible for the motor installation (except when specified by commercial agreement). WEG is not liable for damages to the motor, associated equipment and installation occurred because of:

- Transmission of excessive vibration;
- Poor installations;
- Faulty alignment;
- Improper storage conditions;
- Noncompliance with the instructions before start-up;
- Incorrect electrical connections.

4.8.7.1 Direct coupling

Because of costs, space, absence of belt sliding and greater safety against accidents, direct coupling must be used whenever possible. Also in case of using reduction gearing, direct coupling is recommended.



ATTENTION

Carefully align the shaft ends, and, whenever possible, use flexible coupling, leaving a minimum clearance of 3 mm between the couplings.

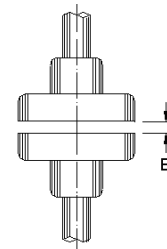

Figure 4.7: Axial clearance

4.8.7.2 Gear coupling

Gear couplings badly aligned generate vibration in the transmission itself and in the motor. Therefore, caution must be taken so that the shafts be perfectly aligned, rigorously parallel in case of spur gear transmissions and in a correct angle in case of transmissions by bevel or helical gears. The gear teeth meshing can be controlled with the insertion of a paper strip, on which the trace of all teeth shows up after a gear turn.

4.8.8 Anchor plate set

The anchor plate set, when used, is composed of the anchor plate, leveling bolts, leveling shims, alignment bolts and anchor bolts.



NOTES

When WEG supplies the anchor plate for fastening and aligning the motor, the dimensional and installation details of the anchor plate are supplied in the specific dimensional drawing of the motor.

The user is responsible for mounting, leveling and grouting the anchor plates (except when specific agreement establishes otherwise).

The anchor bolts must be fastened according to Table 4.8.

Table 4.8: Tightening torque of the anchor bolts

Type Ø	Tightening torque (*) Nm
M30	550
M36	960
M42	1460
M48	2200
M56	3500

* using lubricant paste for the bolts (Molykote P37)

After positioning the motor, perform the final leveling by using the vertical leveling bolts and the leveling shims.



ATTENTION

Protect all the threaded holes to prevent grout from penetrating the threads during the grouting of the anchor plate and anchor bolts.

4.8.9 Leveling

The motor must rest on a surface with flatness of up to 0.08 mm/m.

Verify whether the motor is perfectly leveled both in the vertical and horizontal planes. Make the proper adjustments by placing shims under the motor. The motor leveling must be checked with proper equipment.

Leveling shims

During the motor mounting, leveling shims must be inserted between the motor and the anchor plate, so that the alignment procedure begins with this amount of shims, as follows:

- 3 mm of stainless steel shims (2 mm + 1 mm) or
- 5,40 mm galvanized steel shims (2,7 mm + 2,7 mm)

The other shims shown in Table 4.9 will be kept aside to be used in different combinations in order to obtain the necessary thicknesses to provide the required leveling.

The maximum thickness of the leveling shims must not exceed 4.5 mm.

Table 4.9 shows the quantity of stainless steel shims or galvanized steel shims for each motor support region on the anchor plate.

Table 4.9: Leveling shims

Stainless steel shims		Galvanized steel shims	
Quantity (un.)	Thickness (mm)	Quantity (un.)	Thickness (mm)
2	0,1	2	0,43
2	0,2	2	0,50
2	0,5	1	0,65
2	1	1	0,80
1	2	1	1,95
-	-	2	2,70

4.8.10 Support



NOTE

At least 75% of the support surfaces area of the motor feet must be supported on the base.

4.9 BRAKE

For further information on the installation, operation and maintenance of the brake (if any), refer to the motor dimensional drawing and the specific manual of this equipment.

4.10 HYDRAULIC UNIT

For further information on the installation, operation and maintenance of the hydraulic unit (if any), refer to the motor dimensional drawing and the specific manual of this equipment.

The oil return pipe from the motor bearing to the hydraulic unit must have a minimum inclination from the outlet flange of 15° over the entire length of the pipe.



ATTENTION

For more information on the installation, operation and maintenance of the hydraulic unit (if any), please refer to the dimensional drawing of the engine and the specific manual for this equipment.

5 STARTING

The type of starting used for synchronous motors is specified during the project and depends on the following factors:

- Short-circuit capacity of the power supply;
- Acceptable voltage drop (maximum current with minimum starting voltage);
- Resistive torque and load inertia;
- Starting time;
- Starting duty.

The number of successive starts depends on the used starting procedure.

5.1 DIRECT ON LINE STARTING

It is the simplest and most economically feasible method; however, it must only be used when the starting current does not affect the power grid.

Bear in mind that the starting current of motors may reach 6 to 7 times the rated current value. Therefore, it must be ensured that this current (I_p) will not affect the supply of other consumers because of the high voltage drop in the power grid.

The machine must be started/can be started when the temperature recorded at PT-100's of the three phases is equal to or greater than -20°C

When turning off the machine the heating resistors of the temperature rise circuit must be turned off.

There is an interlocking system so that the main machine's drive circuit breaker is only activated when the temperature recorded on the winding is greater than or equal to -20°C .

This requirement is met in one of the three situations:

- a) When the power grid is "strong" enough and the motor current is negligible in relation to the grid capacity.
- b) The motor is always started without load, which reduces the starting time and, in turn, the duration of the starting current and the momentary voltage drop, which is acceptable for the other consumers of the grid;
- c) When DOL starting is duly authorized by the local electric utility company.

When the motor starting current is high, the following detrimental consequences may occur:

- a) The high voltage drop in the power supply system may cause interference in equipment installed in this system;
- b) The protection system (cables, contactors) must be oversized, increasing the installation costs.



NOTE

In some cases, there is an imposition of the electric utility companies that limits the voltage drop of the grid..

5.1.1 Direct start with discharge resistor

- During the motor starting, the excitation must be OFF and the field must be connected to the discharge resistor, installed in the motor excitation panel;
- When the circuit breaker of the main circuit of the machine is activated, the main field winding supply is blocked by the triggering circuit located in the brushless exciter, which also connects the starting resistor in series with the motor main field winding.
- Through the cage (generally called damper winding), enough torque is developed to accelerate the rotor close to the synchronism rotation;
- The torque to accelerate the rotor is generated by the damper (cage), and when it reaches the planned synchronization speed, the discharge resistor must be

disconnected and the field must be energized with direct current to synchronize the motor;

- Any unbalance or vibration must be investigated.

5.1.2 Direct start without discharge resistor

- In order to start the motor, the exciter field must not be energized by the dc supply of the excitation panel;
- The circuit breaker of the main circuit of the machine is activated and, through the cage (generally called damper winding), enough torque is developed to accelerate the rotor close to the synchronism rotation.
- When the rotor has reached enough speed for synchronization, then the exciter field must be energized to synchronize the motor, which will start spinning at the rotation of the revolving field of the main stator (synchronous rotation).

Any unbalance or vibration must be investigated.

5.1.3 Direct start frequency

Since brushless synchronous motors have a high starting current, the time spent to accelerate loads with high inertia results in a quick rise of the motor temperature. If the intervals between successive starts are too short, the temperature of the windings will rise quickly, reducing their useful life or even burning them. The standards establish a minimum starting duty to which the motors must be able to comply:

- a) Two successive starts, being the first one with the motor cold, i.e., with its windings at ambient temperature, and the second one right afterwards, but after the motor has decelerated to a full stop;
- b) One start with the motor hot, i.e., with the windings at continuous duty temperature.

The first condition simulates the case in which the first motor start is aborted, for instance, by the trip of the motor protection, when a second motor start is permitted right afterwards.

The second condition simulates the case of an accidental motor shutdown under normal operation, for instance, by power outage, when the motor restart is allowed right after the power is reestablished.



NOTE

Special starting conditions must be checked in the specific motor documentation before starting the procedure.

5.1.4 Locked rotor current (I_p/I_n)

The motor nameplate indicates the value of I_p/I_n , which is the relation between the starting current and the rated current of the motor.

5.2 STARTING WITH REDUCED CURRENT

If direct online start is not possible, the following starting systems can be used in order to reduce the starting current:

- With reactor
- With autotransformer
- With frequency inverter
- With soft-starter.



ATTENTION

The selection of the starting method depends on a previous evaluation of the motor performance to validate the procedure.

5.2.1 Starting with reactor

In the starting with reactor, an impedance in the form of a reactor is connected in series to the main terminals of the motor, reducing the voltage at the motor terminals, resulting in a reduction of the starting current. For being a function of the current that passes through the reactor, the impedance gradually reduces the motor acceleration, and when the motor reaches 95% of the rated speed, the reactor is short-circuited, the motor is synchronized and starts operating at full voltage.



ATTENTION

It is necessary assure an acceleration torque that is sufficient to start the motor, because with this starting method there is a substantial reduction in the starting torque.

5.2.2 Starting with autotransformer

The effect of starting with autotransformer is similar to that of starting with reactor. The use of a transformer to limit the voltage reduces the starting current and the torque. The starting torque is reduced proportionally to the line current.

The start of the motor with autotransformer consists of a voltage transformer with taps that allow the operation with reduced voltage until reaching the full voltage. The taps may be modified during starting until reaching the synchronization torque and speed.

5.2.3 Starting with frequency inverter

For the starting and operation of the motor with frequency inverter, refer to the equipment manual.

5.2.4 Starting with soft-starter

The starting procedure with soft-starter is similar to direct start, except for the time to accelerate the load up to the synchronization speed, which is longer.

During the starting process, the soft-starter progressively increases the motor voltage from zero, allowing the motor to accelerate the load up to the rated speed without causing current or torque peaks.

The soft-starter can also be used to control the motor stopping.

5.3 EXCITATION CIRCUIT

The type of excitation circuit used in the asynchronous start of the brushless motor depends on the application, and it may be identified in its specific documentation.

5.3.1 Excitation circuit with voltage control (Random)

The circuit shown in Figure 5.1 works as follows:

- During normal operation of the motor, the exciter rotor and the diodes D1-D6 generate rectified DC voltage to supply field current to the motor according to the exciter field current supplied by an external controlled source;
- During normal operation, the thyristors SCR1 and SCR2 are not conducting;
- During the motor start, the revolving field generated by the motor stator induces a very high alternate voltage in the motor field winding which is proportional to the relation between the number of turns of the stator and the slip;
- In order to prevent damages to the insulation system and to the other component parts of the rotor, the exciter rectifier offers a low impedance path for the current that reduces the induced voltage to acceptable levels preventing the current from circulating through the exciter armature winding;
- When the field induced current is in the positive direction, the diode bridge will deviate the induced field current with a small voltage drop;
- When the induced field current is in the negative direction, the alternate voltage of the field winding is positive by means of the thyristors SCR1, SCR2 and in the triggering circuits;
- The circuit is arranged so that the triggering circuits identify the full voltage. As the alternate voltage increases, the triggering circuits make the SCRs conduct;
- The voltage level of the triggering circuits is specified to be enough above the normal operation field voltage;
- When the motor gets close to the synchronous rotation, the induced field voltage value and the frequency of this voltage get close to zero;
- The exciter field voltage, which until this moment remained not applied by the voltage supply and external control, can now be applied, increasing the exciter DC voltage to the operation levels;
- If the thyristors SCR1 and SCR2 are conducting when the exciter is at a significant voltage, the connection between the crossing of SCR1 and SCR2 and the exciter AC phase will allow the tripping of the thyristors when the motor induced field current is no longer negative.

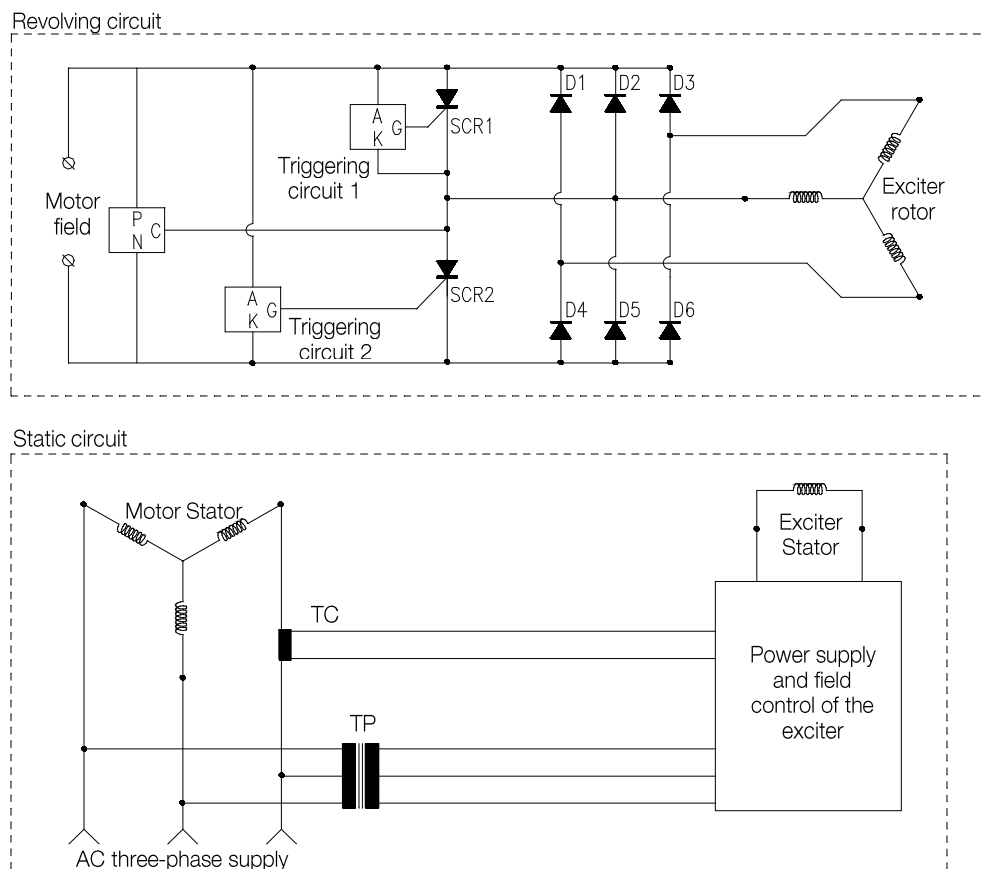

Figure 5.1: Triggering circuit with voltage control

6 COMMISSIONING

When the motor is started for the first time or after a prolonged standstill, several aspects must be considered besides the regular operation procedures.



ATTENTION

- Avoid any contact with electric circuits;
- Even low-voltage circuits may be life threatening;
- In any electromagnetic circuit, overvoltages may occur under certain operating conditions;
- Do not open an electromagnetic circuit suddenly, because the presence of an inductive discharge voltage may break the insulation or injure the operator;
- In order to open those circuits, disconnect switches or circuit breakers must be used.

6.1 PRELIMINARY INSPECTION

Before the first operation of the motor or after long periods out of operation, the following items must be inspected:

1. Check if the motor is correctly aligned;
2. Check if the motor feet were fixed with the torque recommended in this manual. The motor must be doweled to the base;
3. Check if the motor is clean and if the packages, measuring instruments and alignment devices were removed from the motor operating area;
4. Check if the motor is properly grounded;
5. Measure the insulation resistance of the windings, making sure they are within the specified value;
6. Check if coupling connecting components are in perfect operating conditions, duly tightened and greased, when necessary;
7. Check if the bearings are not damaged, if they are properly fixed and aligned;
8. Check if the bearings are properly lubricated. The lubricant must be of the type specified on the nameplate. Check the oil level of oil-lubricated bearings. Bearings with forced lubrication must have the oil pressure and flow as specified in their nameplate;
9. Check if the field control and the excitation system are properly connected according to the instruction in the specific installation manual;
10. Check if the protection relay is parameterized and operating according to the selectivity study;
11. Check if the power grid cables are properly connected to the motor main terminals and ensure they are properly tightened and no short-circuit possibility exists;
12. Inspect the cooling system. In water-cooled motors, inspect the operation of the radiator water supply system. In motors with forced ventilation, check the rotation direction of the fans;
13. Inspect the state of the brush holders and slip rings (if any), ensuring the brushes are well seated and aligned with the slip rings and sliding easily within the brush holders;
14. Motor air inlets and outlets must be unobstructed;
15. The moving parts of the motor must be protected to prevent accidents;
16. The terminal box covers must be properly fastened;
17. Test the high-pressure oil injection system (if any), ensuring its proper operation;
18. Check if the brake is properly fixed and adjusted (if any). Check the operation of the brake control panel;
19. Test the hydraulic unit operation (if any), ensuring its proper operation;
20. When spinning the motor rotor, check if it does not present strange noises.

6.2 FIRST START

6.2.1 Initial starting procedure

After all preliminary inspections have been carried out, proceed according to the directions presented next in order to perform the first start of the uncoupled motor:

1. Turn off the space heater;
2. Set the protections in the motor protection/excitation panel;
3. In oil-lubricated bearings, check the oil level;
4. In bearings with forced-lubrication, start the oil circulation system and check the level, flow and pressure of the oil, making sure that they comply with the data on the nameplate.
5. If the system has an oil flow detection device, it must be waited until the return signal from the oil circulation system of both bearings is received, which makes sure that the oil has reached the bearings;
6. Turn on the industrial water cooling system checking the required flow and pressure (motors with air-water heat exchanger);
7. Turn on the fans (motors with forced ventilation);
8. Switch on the high-pressure oil injection system (if any), keeping it on as informed in the motor technical documentation until the bearings can get the lubrication by self-pumping;
9. Release the brakes (if any);
10. Check the motor rotation direction;



ATTENTION

In order to invert the rotation direction of motors with single direction, it is necessary to consult WEG.

11. Start the motor according to section 7 of this manual;
12. Keep the motor rotating at rated speed and write down the bearing temperatures at 1-minute intervals until they become constant. Any sudden or continuous increase in the bearing temperature indicates lubrication or friction surface abnormality;
13. Monitor the temperature, oil level of the bearings and the vibration levels. If there is a significant variation of any value, interrupt the motor start process, identify possible causes and make the necessary correction;
14. When the bearing temperatures stabilize, it is possible to start the motor with load and operate it normally.



ATTENTION

The noncompliance with the procedures described in section 6.2 may impair the motor performance, cause damages and even lead to its burnout, voiding the warranty.

6.3 OPERATION

After a first successful starting test with no load, couple the motor to the driven load and then perform the starting and operation as follows:

1. Turn off the space heater;
2. Set the protections in the control panel;
3. Switch on the hydraulic unit (if any);
4. Switch on the oil circulation system of the bearings (if any); Check the level, flow and pressure of the oil, making sure that they comply with the data on the nameplate;
5. The pressure or flow return signal of the oil circulation system in the bearings must be confirmed, making sure that the oil has reached the bearings;
6. Start the industrial water cooling system, checking the required flow and pressure (motors with air-water heat exchanger);
7. Turn on the fans (motors with forced ventilation);
8. Switch on the high-pressure oil injection system (if any), keeping it on as informed in the motor technical documentation, until the bearings can get the lubrication by self-pumping;
9. Run the motor coupled to the load until its temperature stabilizes and check for unusual noises, abnormal vibrations or excessive heating. If significant vibration variations occur in the set after the temperature stabilizes, it is necessary to check the alignment and the leveling;
10. Measure and compare the consumed electric current to the value indicated on the nameplate. In continuous duty, without load oscillation, the value of the current measured must not exceed the value indicated on the motor nameplate multiplied by the service factor;



ATTENTION

All the control and measurement instruments must be monitored permanently so that occasional changes will be detected immediately and their causes solved before proceeding with the operation.

6.3.1 Re-synchronization

If the motor loses synchronism, the excitation circuit will present a field current above the normal value of the motor, supplied by the excitation panel before this operating condition.

To put the motor back to synchronism, it is necessary to disconnect the field power supply for a period of two to three seconds after the synchronism loss.

If the motor control system is adjusted for resynchronization after the loss of synchronism, the following criteria must be observed:

1. Disconnect the field supply for at least two seconds in order to allow the motor induced field current to activate the discharge circuit and/or the insertion of the discharge resistor and, thus, reduce the transient torques during resynchronization.
2. The resynchronization time must not exceed the motor normal start sequence time.
3. Normally, the removal of the excitation is necessary for a successful resynchronization;
4. The motor control panel must distinguish start failure from loss of synchronism, so that an attempt of resynchronization will not occur immediately after a start failure.

The quantity and the duration of resynchronization attempts must be limited according to each motor project.

6.3.2 Data recording

The following data must be collected and recorded periodically during the motor operation:

- Temperature of the bearings;
- Oil level of the bearings;
- Stator winding temperature;
- Water inlet and outlet temperatures;
- Vibration level;
- Field and stator voltage and current.

At the beginning of operation, the values must be checked every fifteen minutes. After some hours of operation, check these values every hour. After some time, these intervals may be progressively increased, but those values must be recorded daily for a period of five to six weeks.

6.3.3 Temperatures

- The temperature of the bearings, stator winding and ventilation air (if any) must be monitored while the motor is operating.
- The temperature of the bearings and stator winding stabilize in a period between four to eight hours of operation;
- The stator winding temperature depends on the motor load condition. Therefore, its operation data (voltages, currents, frequency) must be monitored during the motor operation.

6.3.4 Bearings

The system start, as well as the first hours of operation, must be monitored carefully.

Before putting the motor operation, verify:

- If the high-pressure oil injection system (if any) is ON;
- If the external lubrication system (if any) is ON;
- If the used lubricant complies with all specifications;
- The lubricant characteristics;
- The oil level (oil-lubricated bearings);
- If the bearing alarm and trip temperatures are set;
- During the first starting, it is important to pay attention to abnormal vibrations or noises. If the bearing is not running silently and smoothly, the motor must be shut down immediately.
- In case of overheating, the motor must be shut down immediately, bearings and temperature sensors must be inspected and the causes corrected;
- The motor must operate for several hours until bearing temperatures stabilize within the specified limits;
- After the bearing temperatures stabilize, check if there are no leaks through the plugs, gaskets or shaft end.

6.3.4.1 High-pressure oil injection system

In bearings which have the option of shaft lifting when starting or stopping by means of oil pressure, the activation of this system is done by means of an external oil pump, and the following procedure must be observed:



ATTENTION

The high-pressure oil injection system must be switched on before putting the motor into operation and during the shutdown procedure, as informed in the motor technical documentation.

6.3.5 Radiators

During the operation of motors with air-water heat exchanger, it is necessary:

- Control the temperature at the radiator inlet and outlet and, if necessary, correct the water flow;
- Adjust the water pressure just to overcome the resistance in the pipes and in the radiator;
- In order to control the motor operation, it is recommended to install thermometers at the radiator air and water inlet and outlet, recording these temperatures at certain intervals;
- When installing the thermometers, recording or signaling instruments (siren, lights) can also be installed in certain places.

6.3.5.1 Inspection of the performance of the radiator

- For operation control purposes, it is recommended that water and air temperatures at the radiator inlets and outlets be measured and recorded periodically;
- The radiator performance is expressed by the temperatures difference between cold water and cold air during normal operation. This difference must be checked periodically. If an increase in this difference is observed after a long period of normal operation, verify the need for radiator cleaning.
- The accumulation of air inside the radiator can lead to a performance reduction or to its damage. In this case, a deaeration of the radiator and the pipes may solve the problem;
- The water pressure differential can be considered an indicator of the need for cleaning the radiator.
- It is also recommended to measure and record the difference between the water pressure before and after the radiator. Periodically, the newly measured values must be compared to the original value, and an increase of the pressure differential indicates the need for cleaning the radiator.

6.4 SHUTDOWN

In order to stop the motor, proceed as follows:

- Switch off the excitation;
- Open the main stator circuit breaker;
- Switch off the voltage regulator;
- Turn on the high-pressure oil injection system (if any) when the motor reaches the speed specified in the technical documentation;
- Apply the brakes (if any) as informed in the motor technical documentation;

After the motor stops completely:

- Switch off the high-pressure oil injection system (if any);
- Switch off the oil circulation system of the bearings (if any);
- Switch off the hydraulic unit (if any);
- Shut down the industrial water system (if any);
- Switch off the forced ventilation system (if any);
- Switch on the space heaters. They must be kept ON until the next motor operation.



DANGER

Even after switching off the motor, while the rotor is rotating, there is danger to life by touching any of the motor active parts.



ATTENTION

Motor terminal boxes equipped with capacitors must not be opened before their full discharge. Capacitor discharge time: five minutes after shutting down the motor.

7 MAINTENANCE

7.1 GENERAL

A proper maintenance program includes the following recommendations:

- Keep clean the motor and associated equipment;
- Measure the winding insulation resistance periodically;
- Measure the temperature of windings, bearings and cooling system periodically ;
- Check the wear, operation of the lubrication system and useful life of the bearings;
- Measure the motor vibration levels;
- Inspect the cooling system;
- Inspect associated equipment;
- Check all the motor accessories, protections and connections, ensuring that they are operating properly.



ATTENTION

Noncompliance with the recommendations of section may cause undesired stoppages of the equipment.

The frequency of such inspections depends on local application conditions.

Every time that it becomes necessary to transport the motor, the shaft must be properly locked to prevent damages to the bearings. Use the device supplied with the motor to lock the shaft.

If the motor requires reconditioning or replacement of any damaged part, consult WEG.

7.2 GENERAL CLEANING

- Keep the frame clean, without external accumulation of oil or dust, in order to facilitate the heat exchange with the environment;
- The inside of the motor must also be kept clean, and free from dust, debris and oils;
- For cleaning, use brushes or clean cotton cloths. If the dust is not abrasive, the cleaning must be done with an industrial vacuum cleaner, "aspiring" the dirt from the fan cover and the dust accumulated on the fan blades and on the frame;
- The grounding brush compartment (if any) must be kept clean, without dust accumulation;
- Debris impregnated with oil or moisture can be removed with a cloth soaked in appropriate solvents;
- Clean the terminal boxes when necessary. Terminals and connectors must be kept clean, free of rust and in perfect operating conditions. Avoid the presence of grease or verdigris in the connection parts.

7.3 BRUSHES COMPARTMENT CLEANING

- The brushes compartment must be kept clean, without dust accumulation from the wear of the electric brushes;
- The brushes compartment must be cleaned with a vacuum cleaner, removing the dust of the brushes from the motor;
- The slip ring set must be cleaned with a dry clean cloth which does not release lint;
- Clean the spaces between the slip rings with a vacuum cleaner hose with a plastic crevice tool;

- Do not use solvents to clean the slip rings, because the vapors of such products impair the operation of the brushes and the slip rings;
- Air filters (if any) must be removed and cleaned every two months.

7.4 WINDINGS INSPECTION

Yearly, the windings must be submitted to a complete visual inspection, recording and repairing all and every damage or defect observed.

The winding insulation resistance measurements must be done at regular intervals, especially during humid weather and after prolonged motor stoppages. Low values or sudden variations in the insulation resistance must be investigated.

The windings must be submitted to complete visual inspections at frequent intervals, recording and repairing all and every damage or defect observed.

The winding insulation resistance may be increased up to a proper value in points where it is low (due to excessive dust and moisture) by means of dust removal and by drying the winding moisture.

7.5 WINDING CLEANING

In order to obtain a more satisfactory operation and a longer useful life of the insulated windings, it is recommended to keep them free of dirt, oil, metal dust, contaminants, etc.

Therefore, it is necessary to inspect and clean the windings periodically, according to the recommendations of the "Maintenance Plan" of this manual. If reimpregnation is necessary, consult WEG.

The windings may be cleaned with an industrial vacuum cleaner with a non-metallic crevice tool or just a dry cloth.

For extreme dirt conditions, it may be necessary to use a proper liquid solvent for cleaning. This cleaning must be quick to prevent prolonged exposure of the windings to the solvent effects.

After being cleaned with solvents, the windings must be completely dried.

Measure the insulation resistance and the polarization index in order to assess the winding insulation conditions.

Winding drying time after cleaning varies depending on the weather conditions such as temperature, humidity, etc.



DANGER

Most solvents currently used are highly toxic and/or flammable. Solvents must not be used in the straight parts of the coils of high-voltage motors, because they may affect the protection against corona effect.

7.5.1 Inspections

The following inspections must be carried out after the windings are carefully cleaned:

- Check the insulations of the windings and connections.
- Check if spacers, bindings, slot wedges, bandages and supports are properly fixed;

- Check for breaks, faulty welds, short-circuit between turns and against the frame in the coils and connections. In case any fault is detected, consult WEG.
- Ensure that all cables are properly connected and that terminal fixation components are duly tightened. Retighten, if necessary.

7.5.2 Re-impregnation

If any layer of resin on the windings is damaged during cleaning or inspection, such parts must be corrected with adequate material (in this case, consult WEG).

7.5.3 Insulation resistance

The insulation resistance must be measured after the completion of all of the maintenance procedures.



ATTENTION

Before putting the motor back into operation, it is essential to measure the winding insulation resistance and ensure that the measured values meet the specifications.

7.6 COOLING SYSTEM MAINTENANCE

- The pipes of the air-air heat exchanger (if any) must be kept clean and unobstructed to ensure a perfect heat exchange. In order to remove the dirt accumulated in the pipes, a rod with a round brush on the tip may be used.
- In case of air-water heat exchangers, periodic cleaning in the radiator pipes is necessary to remove all and any incrustation.



NOTE

If the motor has filters in the air inlets and/or outlets, they must be cleaned with compressed air. If the dust is difficult to remove, wash the filters with cold water and neutral detergent and dry them in the horizontal position; In case the filters are impregnated with dust containing grease, it is necessary to wash them with gasoline, kerosene or another petroleum solvent or hot water with P3 additive; All the filters must be dried after the cleaning. Do not twist them; Replace the filter if necessary.

7.6.1 Radiators

The degree of dirt in the radiator can be detected by the increase of the temperature at the air outlet. When the temperature of the cold air, under the same operating conditions, exceeds the specified value, it can be assumed that the pipes are dirty.

If corrosion is found in the radiator, it is necessary to provide adequate protection (i.e., zinc anodes, cover with plastic, epoxy or other similar products) in order to prevent further damage to the parts already affected. The external surface of all the radiator parts must be always kept in good conditions.

Instructions for removal and maintenance of the radiator

In order to remove the radiator for maintenance, use the following procedure:

1. Close all the water inlet and outlet valves after stopping the ventilation;
2. Drain the water through the radiator drain plugs;
3. Remove the heads, keeping the bolts, nuts, washers and seals (gaskets) in a safe place;
4. Brush the inside of the pipes carefully with nylon brushes in order to remove residues. If damages to the radiator tubes are found during the cleaning, they must be repaired;
5. Reassemble the heads, replacing the gaskets, if necessary.

7.7 VIBRATION

Any evidence of increase in the unbalance or vibration of the motor must be investigated immediately.



ATTENTION

After torquing or disassembling any machine screw, it is necessary to apply Loctite.

7.8 SLIP RINGS

The slip rings must be kept clean and smooth. They must be cleaned monthly, removing all the dust accumulated between the rings (see section 7.3). In case the slip rings are disassembled, their centering must be ensured in the assembly, in order to prevent ovalization or radial run-outs. It must also be assured the proper positioning of the brushes on the rings (100% contact). In case those procedures are not observed, the slip rings and brushes will present wearing issues.

7.9 BRUSH HOLDER AND BRUSHES

The **brush holders** must stay in the radial direction regarding the slip rings and distant a maximum of 4 mm from the contact surfaces, preventing rupture or damage to the brushes, as shown in Figure 7.1.

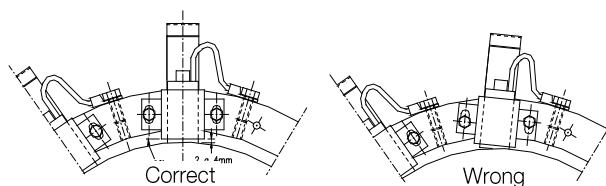

Figure 7.1: Brush holder assembly

Brushes



ATTENTION

The brushes must be inspected weekly in order to ensure their free slide in the brush holder. Worn brushes must be replaced.

The brushes must be replaced by brushes equal to the original ones.

Never mix different kinds of brushes.

Any change in the type or quantity of brushes can only be made with the authorization of WEG.

The brushes must be inspected weekly during operation. Those with excessive wear must be replaced.

In motors that always operate in the same rotation direction, the brushes must be seated in this direction only, and not in alternate movements. During the shaft return movement, the brushes must be lifted (Figure 7.2).

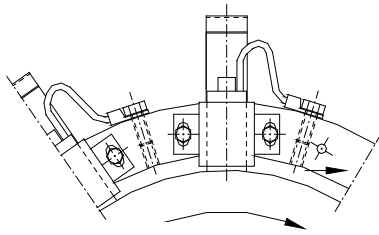

Figure 7.2: Brush seating

The brushes must be seated with even pressure on the contact surface of the ring in order to ensure an even distribution of the current and a low wear of the brushes. It is important that all the assembled brushes have the same contact pressure, with a tolerance of +/- 10%. Greater deviations lead to an uneven current distribution, resulting in an uneven wear of the brushes. The control of the brush pressure is done with a dynamometer. Springs presenting low pressure must be replaced.

7.10 SHAFT GROUNDING DEVICE

The shaft grounding brush (if any) avoids the circulation of electric current through the bearings, which is detrimental to their operation. The brush is put in contact with the shaft and connected by a cable to the motor frame, which must be grounded. Make sure that the brush holder fastening and its connection to the frame have been made correctly.

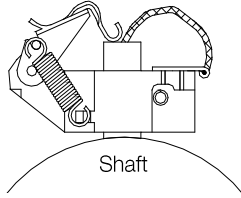

Figure 7.1: Shaft grounding brush

Drying oil is used to protect the motor shaft against rust during transportation. In order to ensure the proper operation of the grounding brush, this oil, as well as any residue between the shaft and the brush, must be removed before starting the motor. The brush must be constantly monitored during operation, and it must be replaced by another one of the same quality (granulation) at the end of its useful life.

7.11 EXCITER MAINTENANCE

7.11.1 Exciter

In order to have a good performance of its components, the motor exciter compartment must be kept clean. Clean it regularly, following the procedures described in this manual.

Windings

Check the main exciter and auxiliary exciter winding insulation resistance regularly so as to determine their insulation conditions, following the procedures described in this manual.

7.12 BEARING MAINTENANCE

7.12.1 Grease-lubricated rolling bearings

7.12.1.1 Lubrication instructions

The lubrication system was designed in such a way that during the lubrication of the rolling bearings, all the old grease is removed from the rolling bearing races and expelled through a drain which enables the exit of the grease, but prevents the ingress of dust or other harmful contaminants.

This drain also prevents damage to the rolling bearings by the known problem of excessive lubrication.

It is recommended to make the lubrication with the motor in operation in order to ensure the renewal of the grease in the rolling bearing housing.

If that is not possible due to the presence of rotating parts near the grease nipple (pulleys, etc.) which may put the operator at risk, follow the procedures below:

- With the motor stopped, inject approximately half of the total intended amount of grease and operate the motor for approximately one minute at rated speed;
- Stop the motor and inject the rest of the grease.



ATTENTION

The injection of all the grease with the motor stopped may lead to the penetration of part of the lubricant into the motor through the internal seal of the rolling bearing cap.

It is important to clean the grease nipples prior to lubrication in order to prevent foreign materials from being dragged into the rolling bearing. For lubrication, use only manual grease gun.



NOTE

The rolling bearing data, amount and type of grease and lubrication intervals are informed on a bearing nameplate affixed to the motor. Check this information before performing the lubrication.

- The lubrication intervals informed on the nameplate consider a 70°C working temperature of the rolling bearing;
- Based on the operating temperature ranges listed in Table 7.1, apply the following correction factors for the rolling bearing lubrication intervals:

Table 7.1: Reduction factor for lubrication intervals

Bearing operating temperature	Reduction factor
Below 60 °C	1.59
Between 70 and 80 °C	0.63
Between 80 and 90 °C	0.40
Between 90 and 100 °C	0.25
Between 100 and 110 °C	0.16

7.12.1.2 Procedures for rolling bearing relubrication

1. Remove the drain cover;
2. Clean with a cotton cloth around the hole of the grease nipple;
3. With the rotor operating, inject the grease with a manual grease gun until grease starts coming out from the drain or until the proper amount of grease has been injected.
4. Keep the motor running long enough so that the grease excess passes through the drain;
5. Inspect the bearing temperature to make sure there was no significant change;
6. Put the drain plug back in place.

7.12.1.3 Rolling bearing relubrication with drawer device for grease removal

In order to relubricate the bearings, the old grease is removed by means of the device with a drawer installed on each bearing.

Lubrication procedure:

1. Before starting the lubrication of the bearing, clean the grease nipple with a cotton cloth;
2. Remove the rod with drawer to remove the old grease, clean the drawer and put it back in place;
3. With the motor running, inject the amount of grease specified on the rolling bearing nameplate by means of a manual grease gun;
4. The excess of grease comes out through the bearing lower drain and is deposited in the drawer;
5. Keep the motor running long enough for the grease excess to drain;
6. Remove the excess of grease, by pulling the drawer rod and cleaning the drawer. This procedure must be repeated as many times as necessary until the drawer no longer retains grease;
7. Inspect the bearing temperature to ensure that there was no significant change.

7.12.2 Type and amount of grease

The relubrication of the bearings must always be done with the original grease, specified on the bearing nameplate and in the documentation of the motor.



ATTENTION

WEG does not recommend the use of greases different from the original one.

It is important to perform a correct lubrication, i.e. to apply the correct grease and in the proper quantity, because either poor or excessive lubrication will damage the rolling bearings.

Excessive amount of grease cause temperature increase, due to the great resistance it offers to the movement of the bearing rotating parts. Consequently, due to the heating, the grease can completely lose its lubricating characteristics.

7.12.3 Grease compatibility

You can say that greases are compatible when the properties of the mixture lie within the property ranges of the greases individually. In general, greases with the same type of soap are compatible; however, depending on the proportion of the mixture, there might be incompatibility. Therefore, it is not recommended to mix

different types of grease without consulting the grease supplier or WEG.

Some thickeners and basic oils cannot be mixed, because they do not form a homogeneous mixture. In this case, one cannot rule the possibility of hardening or softening of the grease, or reduction of the dropping point of the resulting mixture.



ATTENTION

Greases with different types of base must never be mixed.
For example: Lithium-based greases must never be mixed with sodium or calcium-based greases.

7.12.4 Bearing disassembly

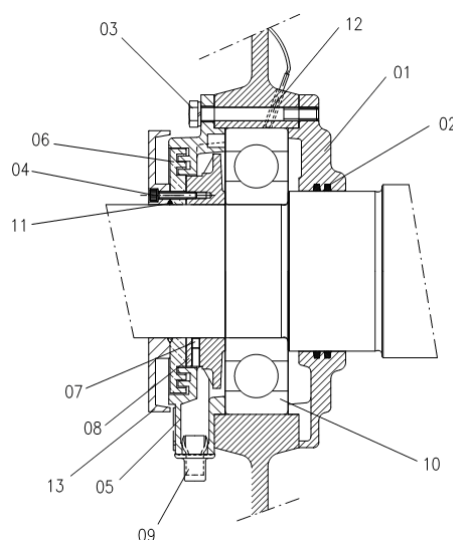

Figure 7.3: Parts of the grease-lubricated rolling bearing

Figure 7.3 legend:

1. Inner bearing cap
2. White felt
3. Bearing cap fastening screw
4. Disc fastening screw
5. Outer bearing cap
6. Labyrinth taconite seal
7. Grease flinger fastening screw
8. Grease flinger
9. Grease collecting drawer
10. Rolling bearing
11. Grease nipple
12. Thermal protector
13. External closing disc

Before disassembling:

- Remove the extension tubes from the grease inlet and outlet;
- Thoroughly clean the external part of the bearing;
- Remove the grounding brush (if any);
- Remove the temperature sensors from the bearing

Disassembly

In order to disassemble the bearing, proceed according to the directions below:

1. Remove the screws (4) that fix the closing disc (13);
2. Remove the Labyrinth taconite seal (6);
3. Remove the screws (3) from the bearing caps (1 and 5);
4. Remove the outer bearing cap (5);
5. Remove the screw (7) that fixes the grease flinger (8);

6. Remove the grease flinger (8);
7. Remove the D-end shield;
8. Remove the rolling bearing (10);
9. Remove the inner bearing cap (1), if necessary.



ATTENTION

- During the bearing disassembly, it is necessary to be careful not to damage the balls, rollers or shaft surface;
- Keep the disassembled parts in a safe and clean place.

7.12.4.1 Bearing assembly

- Clean the bearings completely and inspect the disassembled parts and the inside of the bearing caps;
- Make sure the rolling bearing, shaft and bearing cap surfaces are perfectly smooth;
- Fill up to ¾ of the inner and outer bearing cap deposits with the recommended grease (Figure 7.4) and lubricate the rolling bearing with enough grease before assembling it;
- Before assembling the rolling bearing on the shaft, heat it up to a temperature between 50 °C and 100 °C;
- For the complete assembly of the bearing, follow the disassembly instructions in the reverse order.
- The efficiency of sealing against taconita will be given by the filling of grease between the protrusions of the labyrinth seal and outer ring (if any)

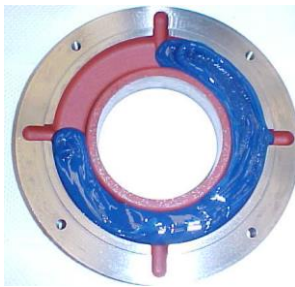

Figure 7.4: Outer bearing cap



ATTENTION

When the bearing is opened, inject the new grease through the grease nipple to expel the old grease found in the grease inlet tube, and apply the new grease in the rolling bearing, to the inner and outer rings, filling 3/4 of the empty spaces, as shown in Figure 7.4. In case of double bearings (ball bearing + roller bearing), also fill 3/4 of the empty spaces between the intermediate rings. Never clean the rolling bearing with cotton-based cloths, because they leave some lint, working as solid particles.



NOTE

WEG is not liable for the change of grease or for any damages arising from this change.

7.12.5 Oil-lubricated rolling bearing

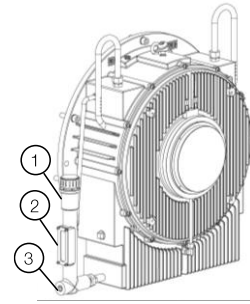

Figure 7.5: Oil-lubricated rolling bearing

Figure 7.5 legend:

1. Oil inlet
2. Oil sight glass
3. Oil outlet

7.12.5.1 Lubrication instructions

Oil drainage: When it is necessary to change the bearing oil, remove the oil outlet plug (3) and drain the oil completely.

To fill the bearing with oil:

- Close the oil outlet with the plug (3);
- Remove the oil inlet plug (1);
- Fill it with the specified oil up to the level indicated in the oil sight glass.



NOTES

1. All threaded holes that are not used must be closed with plugs and no fitting may present leaks;
2. The oil level is reached when the lubricant can be seen approximately in the middle of the sight glass;
3. The use of excessive amount of oil will not damage the bearing; but it can cause leaks through the shaft seals;
4. Never use hydraulic oil or mix it with the bearing lubricant oil.

7.12.5.2 Oil type

The type and quantity of the **lubricant oil** to be used are specified on the nameplate affixed to the motor.

7.12.5.3 Oil change

The bearing oil change must be done according to the intervals, which depend on the bearing operating temperatures, shown in Table 7.2:

Table 7.2: Oil change intervals

Bearing operating temperature	Bearing oil change intervals
Below 75 °C	20,000 hours
Between 75 and 80 °C	16,000 hours
Between 80 and 85 °C	12,000 hours
Between 85 and 90 °C	8,000 hours
Between 90 and 95 °C	6,000 hours
Between 95 and 100 °C	4,000 hours

The lifespan of the bearings depends on their operating conditions, on the motor operating conditions and on the maintenance procedures.

Proceed according to the following directions:

- The oil selected for the application must have the proper viscosity for the bearing operating temperature. The type of oil recommended by WEG already considers these criteria;
- Insufficient quantity of oil may damage the bearing;
- The minimum recommended oil level is reached when the lubricant can be seen in the lower part of the oil sight glass with the motor stopped.

ATTENTION

The oil level must be inspected daily and must remain in the middle of the oil sight glass.

7.12.5.4 Bearing operation

The system start, as well as the first hours of operation, must be monitored carefully.

Before starting, check:

- If the oil used complies with the specification on the nameplate;
- The lubricant characteristics;
- The oil level;
- The alarm and trip temperatures set for the bearing.

During the first start, it is necessary to stay alert for unusual vibrations or noises. If the bearing does not operate in a silently and smooth way, the motor must be shut down immediately. The motor must operate for some hours until the bearing temperatures stabilize. In case of overheating of the bearings, the motor must be shut down for inspection of the bearings and temperature sensors.

Check if there is no oil leak through the plugs, gaskets or shaft end.

7.12.5.5 Bearing disassembly

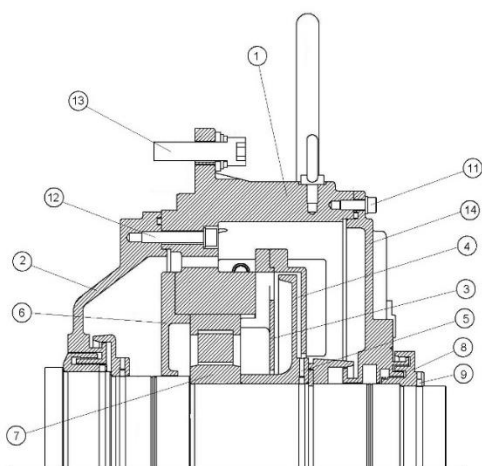

Figure 7.6: Parts of the oil-lubricated rolling bearing

Figure 7.6 legend:

1. Outer oil tank
2. Inner oil tank
3. Outer bearing cap
4. Oil flinger
5. Screw
6. Inner bearing cap
7. Rolling bearing
8. Labyrinth taconite seal
9. Screw
10. Breather
11. Outer tank fastening screw
12. Inner tank fastening screw
13. End shield fastening screw
14. Bearing protection cover

Before disassembling:

- Clean the whole bearing externally;
- Remove the oil completely from the bearing;
- Remove the temperature sensor from the bearing;
- Remove the grounding brush (if any);
- Provide a support for the shaft in order to hold the rotor during the disassembly.

Disassembly:

In order to disassemble the bearing, proceed according to the following guidelines:

1. Remove the screw (9) that fastens the labyrinth taconite seal (8);
2. Remove the labyrinth taconite seal (8);
3. Remove the screws (11) that fasten the bearing protection cover (14);
4. Remove the protection cover (14);
5. Remove the screws (5) that fasten the oil flinger (4) and remove it;
6. Remove the bolts that fix the external bearing cap (3) and remove it;
7. Remove the screws (12 and 13);
8. Remove the outer oil tank (1);
9. Remove the rolling bearing (7);
10. If complete disassembly of the bearing is necessary, remove the inner bearing cap (6) and the inner oil tank (2).

ATTENTION

- During the bearing disassembly, it is necessary to be careful not to damage the balls, rollers or shaft surface;
- Keep the disassembled parts in a safe and clean place.

7.12.5.6 Bearing assembly

- Clean the rolling bearing and the oil tanks thoroughly, and inspect all the parts before the bearing assembly.
- Make sure the rolling bearing contact surfaces are smooth and free of signs of scratches or corrosion;
- Before inserting the rolling bearing onto the shaft, heat it up to a temperature between 50 to 100 °C;
- For the complete assembly of the bearing, follow the disassembly instructions in the reverse order.

ATTENTION

During the bearing assembly, apply sealant (e.g. Curil T) in order to seal the surfaces of the oil tank.

7.12.6 Sleeve bearings

7.12.6.1 Bearing data

Dry sump bearings or those that use two oil outlets per bearing do not have an oil level sight glass. It is therefore not necessary to check the oil level.

The characteristic data, such as oil flow, quantity and type, are indicated on the bearing nameplate and must be strictly observed; otherwise, overheating and damages to the bearings may occur. The hydraulic installation (for bearings with forced lubrication) and oil the supply for the motor bearings are responsibilities of the user.

7.12.6.2 Bearing installation and operation

For information on the bill of materials, assembly and disassembly instructions, and maintenance details, refer to the specific installation and operation manual of the bearings.

7.12.6.3 Cooling by water circulation

The sleeve bearings with cooling by water circulation have a serpentine inside the oil tank through which the water circulates.

In order to assure an efficient bearing cooling, the circulating water must have at the bearing inlet a temperature below or equal to the ambient, so that the cooling takes place.

The water pressure must be 0.1 bar and the flow equal to 0.7 l/s. The pH must be neutral.



NOTE

Under no circumstances can water leak into the oil tank, because this will contaminate the lubricant.

7.12.6.4 Oil change

Self-lubricated bearings:

The bearing oil change must be done according to the intervals, which depend on the bearing operating temperatures, shown in Table 7.3:

Table 7.3: Oil change intervals

Bearing operating temperature	Bearing oil change intervals
Below 75 °C	20,000 hours
Between 75 and 80 °C	16,000 hours
Between 80 and 85 °C	12,000 hours
Between 85 and 90 °C	8,000 hours
Between 90 and 95 °C	6,000 hours
Between 95 and 100 °C	4,000 hours

Bearings with (external) oil circulation:

The oil of the bearings must be changed every 20,000 hours of operation or whenever the lubricant presents modifications in its characteristics. The oil viscosity and pH must be checked regularly.



NOTE

The oil level must be inspected daily, and it must remain in the middle of the oil sight glass.

The bearings must be lubricated with the specified oil, observing the flow rate informed on their nameplate; All threaded holes that are not used must be closed with plugs and no fitting may present leaks. The oil level is reached when the lubricant can be seen approximately in the middle of the sight glass. The use of a larger amount of oil will not damage the bearing; but it can cause leaks through the shaft seals.



ATTENTION

The care with the lubrication will determine the useful life of the bearings and the safety in the motor operation. Therefore, the following recommendations must be observed:

- The selected lubricant oil must be the one with proper viscosity for the operating temperature of the bearings. That must be observed at every oil change or periodical maintenances;
- Never use or mix hydraulic oil with the lubricant oil of the bearings;
- Lack of lubricant, due to incomplete filling or non-monitoring of the level, can damage the bearing shells;
- The minimum oil level is reached when the lubricant can be seen in the lower part of the sight glass with the motor stopped.

7.12.7 Sealings

Make visual inspection of the sealings, making sure that the dragging marks of the seals on the shaft do not compromise its integrity and checking for cracks and broken parts. Cracked or broken parts must be replaced. In case of bearing maintenance, in order to assemble the seal, it is necessary to carefully clean the seal contact surfaces and its enclosure, and cover the sealing with a non-hardening component (e.g.: Curil T). The two halves of the labyrinth taconite seal must be joined by a garter spring.

The drain holes located in the lower half of the seal must be cleaned and unobstructed.

Improper installation can damage the sealing and cause oil leakage.



ATTENTION

For further information on the disassembly and assembly of sleeve bearing seals, refer to the specific manual of this equipment.

7.12.8 Sleeve bearing operation

The system start, as well as the first hours of operation, must be monitored carefully.

Before starting, check:

- If the oil inlet and outlet tubes (if any) are clean. Clean the tubes by pickling, if necessary;
- If the used oil complies with the specification on the nameplate;
- The lubricant characteristics;
- The oil level;
- The alarm and trip temperatures set for the bearing.

During the first start, it is necessary to stay alert for unusual vibrations or noises. If the bearing is not running silently and smoothly, the motor must be shut down immediately.

The motor must operate for several hours until the bearing temperatures stabilize. In case of overheating of the bearings, the motor must be shut down for inspection of the bearings and temperature sensors.

Check if there is no oil leak through the plugs, gaskets or shaft end.

7.12.9 Sleeve bearing maintenance

The sleeve bearing maintenance includes:

- Periodic checking of the oil level and its lubricating conditions;
- Checking the bearing noise and vibration levels;
- Monitoring of the operating temperatures and retightening of the fastening and assembly screws;
- In order to facilitate the heat exchange with the environment, the frame must be kept clean, without external oil or dust accumulation;
- The NDE bearing is electrically insulated. The spherical seat surfaces of the bearing shell on the frame are covered with insulating material. Never remove this cover;
- The anti-rotation pin is also insulated, and the seals are made of non-conducting material;

Temperature control devices that are in contact with the bearing shell must also be properly insulated.

7.12.10 Protection setting



ATTENTION

The following temperatures must be set on the bearing protection system:

ALARM: 110 °C

TRIP: 120 °C

The alarm temperature must be set for 10 °C above the operating temperature, not exceeding the limit of 110 °C.

7.12.11 Disassembly/assembly of the bearing temperature sensors

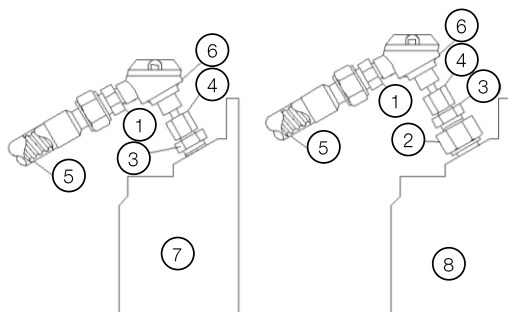

Figure 7.7: Pt100 on the bearings

Figure 7.7 legend:

1. Reduction nipple
2. Insulating adapter
3. Locknut
4. Bulb
5. Flexible metal tube
6. Pt-100 temperature sensor
7. Non-insulated bearing
8. Insulated bearing

Disassembly instructions:

If it is necessary to remove the Pt100 for bearing maintenance, proceed according to the following instructions:

- Remove the Pt100 carefully, locking the locknut (3) and unscrewing just the Pt100 from the bulb (4);
- Parts (2) and (3) must not be disassembled.

Assembly instructions:



ATTENTION

Before assembling the Pt100 on the bearing, check if it does not contain marks of knock or any other damage that may compromise its operation.

- Insert the Pt100 into the bearing;
- Restrain the locknut (3) with a wrench;
- Screw the bulb (4), adjusting it so that the tip of the Pt100 touches the contact surface of the bearing.



NOTES

- The assembly of the Pt100 on non-insulated bearings must be done directly on the bearing, without the insulating adapter (2);
- The tightening torque to assemble the Pt100 and the adapters must not exceed 10 Nm.

8 MOTOR DISASSEMBLY AND ASSEMBLY



ATTENTION

All the repair, disassembly and assembly services must be performed only by properly qualified and trained professionals; otherwise, equipment damage and personal injury may occur. If any further explanations are necessary, consult WEG.

The disassembly and assembly sequence depend on the motor model.

Always use proper tools and devices. Any damaged part (cracks, dents on machined parts, faulty threads) must be replaced, avoiding restorations..

8.1 PARTS

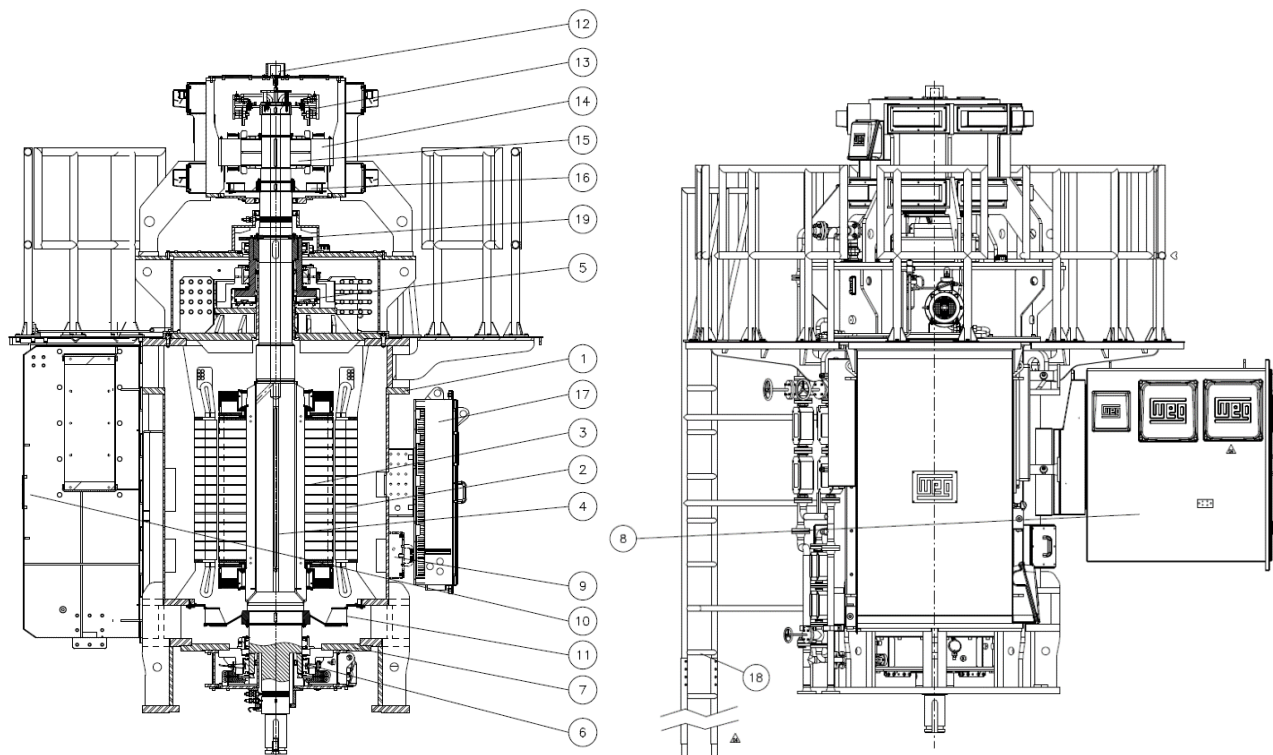

	Description	WEG Item
1	FRAME	12779912
2	STATOR	12759989
3	ROTOR	12758799
4	SHAFT	12783782
5	TOP BEARING	12744124
6	BOTTOM BEARING	12744125
7	BOTTOM BEARING BRACKET	12774367
8	SATOR TERMINAL BOX	12774043
9	SPACE HEATERS	12589577
10	HEAT EXCHANGER	12763575
11	FAN	12775260
12	ENCODER	12784507
13	RECTIFIER WHEEL	12799035
14	STATOR OF MAIN EXCITER	10148358
15	ROTOR OF MAIN EXCITER	12784947
16	FAN OF EXCITATION	11815521
17	ACCESSORIES TERMINAL BOX	12778648
18	LADDER	12791326
19	AXIAL PROBE PROVISION	12779975

8.2 DISASSEMBLY

The following precautions must be taken when disassembling the electric motor:

1. Always use proper tools and devices to disassemble the motor;
2. Before disassembling the motor, disconnect the cooling water and lubrication pipes (if any);
3. Disconnect the motor electrical connections and those of the accessories;
4. Remove the heat exchanger and the noise suppressor (if any);
5. Remove the bearing temperature sensors and the grounding brush;
6. In order to prevent damages to the rotor and coil heads, support the shaft on both drive and non-drive ends;
7. In order to disassemble the bearings, follow the procedures described in this manual;
8. The removal of the rotor from the motor must be done with a suitable device and with extreme care so that the rotor does not drag on the stator laminated core or coil heads, thus preventing damages.

8.3 ASSEMBLY

Below are some cares to be observed when the motor is assembled:

1. Always use proper tools and devices to assemble the motor;
2. To assemble the motor, use the disassembly procedure in the reverse order;
3. Any damaged part (cracks, dents on machined parts, faulty threads) must be replaced, always avoiding restorations.

Table 8.1 shows the recommended tightening torques of the bolts for the assembly of the motor or its parts:

Table 8.1: Bolt tightening torque

Material / Resistance class		Carbon steel / 8.8 or above		Stainless steel / A2 – 70 or above	
Type of fastening		Metal / Metal	Metal / Insulation	Metal / Metal	Metal / Insulation
% Yield strength		60%	33%	70%	33%
Diam.	Pitch (mm)	Tightening torque of the screws (Nm)			
M3	0.5	0.9	0.5	0.75	0.4
M4	0.7	2.1	1	1.8	1
M5	0.8	4.2	2	3.6	1.7
M6	1	8	4.4	6.2	3.4
M8	1.25	19.5	10.7	15	8.3
M10	1.5	40	21	30	16.5
M12	1.75	68	37	52	28
M14	2	108	60	84	46
M16	2	168	92	130	72
M18	2.5	240	132	180	100
M20	2.5	340	187	255	140
M22	2.5	470	260	350	190
M24	3	590	330	440	240
M27	3	940	510	700	390
M30	3.5	1170	640	880	480
M33	3.5	1730	950	1300	710
M36	4	2060	1130	1540	840
M42	4.5	3300	1800	2470	1360
M48	5	5400	2970	4050	2230



NOTE

- The strength class is usually indicated on the head of the hexagonal bolt;
- When there is no marking on the bolt, it indicates that the strength class of the bolt is 4.6;
- Allen-type hexagon socket cap bolts have strength class 12.9.

8.4 AIR GAP MEASUREMENT

After disassembling and assembling the motor, it is necessary to measure the air gap in order to check the concentricity between rotor and stator.

Measure the air gap between the metal support of the shaft seal the motors, measure shaft at four shaft equidistant points (45°, 135°, 225° and 315°). The difference between the air gap measurements at two diametrically opposed points should be less than 10% of the average air gap.



NOTA

When the motor is supplied disassembled, an assembly manual is provided with it, describing the procedures for assembly on site. Always use proper tools and devices to assemble the motor. Any damaged part (cracks, dents on machined parts, faulty threads) must be replaced, always avoiding restorations.



ATTENTION

The bearing can only be closed after completion and projected from the air gap

For the single bearing:

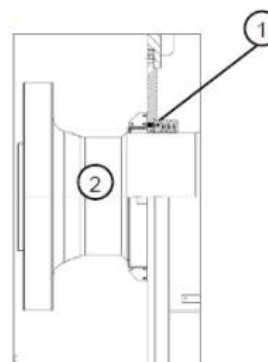

Figure 8.1: DE shaft seal

Legend of Figure 8.1

1. DE shaft seal
2. Motor shaft

8.5 GENERAL RECOMMENDATIONS



ATTENTION

All services described herein must be performed by specialized and experienced personnel; otherwise, personal injuries or damages to the equipment may occur. If you have any questions, contact WEG.

9 MAINTENANCE PLAN

The maintenance plan described in Table 9.1 is only referential, considering that the intervals between each maintenance intervention may vary according to the motor location and operating conditions.

Table 9.1: Maintenance plan

EQUIPMENT	Weekly	Monthly	3 months	6 months	Annually	3 years	Note
STATOR							
Visual inspection of the stator.					x		
Cleanliness control.					x		
Inspection of slot wedges.						x	
Check of the fastening of the stator terminals.					x		
Measurement of the winding insulation resistance.					x		
ROTOR							
Cleanliness control.					x		
Visual inspection.					x		
Inspection of the shaft (wear, incrustations).						x	
EXCITER							
Cleaning control				x			
Test diodes, thyristors and varistors					x		
Inspect the windings					x		
Inspect connections and operation of triggering circuit					x		
BEARINGS							
Noise, vibration, oil flow, leak and temperature control	x						
Lubricant quality control					x		
Inspect the bearing shell and shaft track (sleeve bearing)						x	
Change the lubricant							According to period indicated on the bearing nameplate
AIR-WATER HEAT EXCHANGER							
Inspection of the radiators.					x		
Cleaning of the radiators.					x		
Replacement of the gaskets of the radiator heads.					x		
TERMINAL BOX AND GROUNDING TERMINALS							
Internal cleaning of the terminal boxes.					x		
Retightening of the screws.					x		
PROTECTION AND CONTROL EQUIPMENT							
Test operation					x		
Record values	x						
Disassemble and test its operation						x	
COUPLING							
Inspect alignment					x		Check after first week of operation
Inspect fixation					x		
WHOLE MOTOR							
Inspect noise and vibration	x						
Drain condensate			x				
Retighten the bolts					x		
Clean terminal boxes					x		
Refasten electric and grounding connections					x		

10 ABNORMALITIES, CAUSES AND SOLUTIONS



NOTE

The instructions of Table 10.1 present only a basic list of abnormalities, causes and corrective actions. In case of questions, consult WEG.

Table 10.1: Basic list of abnormalities, causes and corrective actions

ABNORMALITY	POSSIBLE CAUSES	CORRECTION
Neither coupled nor uncoupled does the motor start	▪ At least two power cables are interrupted, without voltage	▪ Check the control panel, the power cables, and the terminals.
	▪ Rotor is locked	▪ Unlock the rotor
	▪ Damaged bearing	▪ Repair or replace the bearing
	▪ Excessive load at start	▪ Check the load characteristics at start
	▪ Stator circuit is open	▪ Measure and compare the stator phase resistances
	▪ Problems in the brushes	▪ Brushes may be worn, dirty or seated incorrectly
	▪ Open field winding	▪ Check the logic for the application logic of the excitation system field
Motor starts with no load, but fails when load is applied It starts very slowly and will not reach the rated speed	▪ Power supply voltage is too low	▪ Measure the power supply voltage, and set it to the correct value
	▪ Very high voltage drop in the power cables	▪ Check the cross section of the power cables
	▪ Rotor bars (damper winding) are damaged or interrupted	▪ Check and repair the rotor bars (cage)
	▪ A power cable was interrupted after the start	▪ Check the connection of the power cables
Very high no load current	▪ Failure in excitation (power factor too low – out of synchronism)	▪ Check the power factor and correct the failure in the excitation
Hot spots in the stator winding	▪ Short-circuit between turns	▪ Rewind the stator
	▪ Interruption of the parallel wires or phases of the stator winding	
	▪ Defective electrical connections	▪ Redo the connections
Stator winding becomes very hot under load	▪ Fans operating in the wrong direction	▪ Correct the rotation direction of the fans
	▪ Inadequate cooling due to dirt in the heat exchanger (if any)	▪ Clean the pipes of the heat exchanger
	▪ Overload	▪ Measure the stator voltage, reduce the load, check the motor application
	▪ Excessive number of starts or very high load inertia	▪ Reduce the number of starts
	▪ Supply voltage too high, increasing the iron loss	▪ Do not exceed 110% of the rated voltage, except otherwise specified on the nameplate
	▪ Supply voltage is too low, therefore the current is too high	▪ Check the supply voltage and the voltage drop on the motor
	▪ Interruption in a power cable or in a winding phase	▪ Measure the current in all the phases and, if necessary, correct it
	▪ Rotor drags against the stator	▪ Check the air gap, operating conditions (vibration...), bearing conditions
	▪ The operating condition does not correspond to the data on the nameplate	▪ Keep the operating condition according to the motor nameplate reduce the load
	▪ Unbalance in the power supply (blown fuse, wrong command)	▪ Check if there is voltage unbalance or operation with two phases and correct it
	▪ Obstructed ventilation (air inlet or outlet)	▪ Remove obstructions from the air inlet and outlet

ABNORMALITY	POSSIBLE CAUSES	CORRECTION
Hot spots in the rotor	▪ Interruptions or failure in the insulation of the rotor winding	▪ Repair the rotor winding
	▪ Motor overexcited	▪ Check and correct the exciting current
Heating in the damper winding (rotor)	▪ High negative sequence current	▪ Correct voltage unbalance; ▪ Check the line harmonics (correct)
Abnormal noise during operation with load	▪ Mechanical causes: The noise normally decreases when the speed reduces; see also: "noisy operation when uncoupled"	▪ Check mechanical causes (balancing, alignment, coupling and bearings)
	▪ Electrical causes: The noise ceases when the motor is shut down. Consult the manufacturer	▪ Perform electrical and magnetic analysis
When coupled, there is noise; when uncoupled, the noise disappears	▪ Defect in the coupling parts or in the driven machine	▪ Check the power transmission, the coupling and the alignment
	▪ Defect in the gear coupling	▪ Align the driving set, check the gear box position
	▪ Defect in the coupling	▪ Align the motor and the driven machine
	▪ Problems in the foundation	▪ Repair the foundation
	▪ Faulty balancing of the components or of the driven machine	▪ Perform new balancing
	▪ Power supply voltage is too high	▪ Check the supply voltage and the current with no load
	▪ Wrong rotation direction of the motor	▪ Invert the connection of two phases
Noisy operation when uncoupled	▪ Unbalance. Noise remains during deceleration after disconnecting the voltage.	▪ Perform new balancing
	▪ Interruption in one phase of the stator winding	▪ Measure the current at all connecting cables
	▪ Fastening screws are loose	▪ Retighten and lock the screws
	▪ The rotor balancing conditions become worse after the assembly of the coupling	▪ Balance the coupling
	▪ Resonance in the foundation	▪ Adjust the foundation
	▪ Motor frame is deformed	▪ Check flatness of the base
	▪ Bent shaft	▪ Correct or replace the shaft ▪ Check the rotor balancing and eccentricity
	▪ Air-gap is not even	▪ Check shaft warping or rolling bearing wear
Sparking	▪ Badly seated brushes	▪ Correct the seating of the brushes and adjust a normal and even pressure
	▪ Low pressure between the brushes and rings	▪ Correct the pressure of the spring through the adjustment (if any) or replace the springs or the brush holder
	▪ Overload	▪ Adjust the load to the motor characteristics or dimension a new motor for the application
	▪ Slip rings in poor conditions (ovalized, rough surfaces, with grooves...)	▪ Machine the slip rings
	▪ Brushes stuck in their housing	▪ Check the mobility of the brushes in the compartments
	▪ Excessive vibration	▪ Check cause of the vibration and correct it
	▪ Low exciting current causing damages to the slip rings	▪ Adjust the brushes to the real excitation operating condition and machine the slip rings

11 DECLARATION OF CONFORMITY

EU Declaration of Conformity



Manufacturers:

WEG Equipamentos Elétricos S.A.
 Av. Prefeito Waldemar Grubba, 3000
 89256-900 - Jaraguá do Sul – SC – Brazil
www.weg.net

WEG Industrie (India) PVT. LTD.
 Plot nº E-20 (North), SIPCOT Industrial Complex
 Phase II – Expansion II.
 Mornapalli Village, Hosur 635 109
 Tamil Nadu - India
www.weg.net/in

WEG MEXICO, S.A. DE C.V
 Carretera Jorobas - Tula Km 3.5, Manzana 5,
 Lote 1, Fraccionamiento Parque Industrial Huehuetoca,
 Municipio de Huehuetoca, C.P. 54680,
 CD. de Mexico y Área Metropolitana – Mexico
www.weg.net/mx

WEG (Nantong) Electric Motor Manufacturing CO., LTD.
 No. 128# - Xinkai South Road, Nantong
 Economic & Technical Development
 Zone, Nantong, Jiangsu Province – China
www.weg.net/cn

WEGeuro – Industria Eléctrica S.A.
 Rua Eng Frederico Ulrich,
 4470-605 – Maia – Porto – Portugal
www.weg.net/pt
 Contact person: Luís Filipe Oliveira Silva Castro Araújo
 Authorised Representative in the European Union
(Single Contact Point)

The manufacturer declares under sole responsibility that:

WEG synchronous and asynchronous motors, WEG generators and their components used for following lines:

M..., W60, WGM, G...S and AN10

.....

when installed, maintained and used in applications for which they were designed, and in compliance with the relevant installation standards and manufacturer's instructions, comply with the provisions of the following relevant European Union harmonization legislation, wherever applicable:

Low Voltage Directive 2014/35/EU*
Machinery Directive 2006/42/EC**

EMC Directive 2014/30/EU (electric motors are considered inherently benign in terms of electromagnetic compatibility)

The fulfilment of the safety objectives of the relevant European Union harmonisation legislation has been demonstrated by compliance with the following standards, wherever applicable:

**EN 60034-1:2010 + AC:2010/ EN 60034-3:2008 / EN 60034-5:2001 + A1:2007/ EN 60034-6:1993/
 EN 60034-7:1993 + A1:2001/ EN 60034-8:2007 + A1: 2014/ EN 60034-9:2005 + A1:2007/
 EN 60034-11:2004/ EN 60034-12:2002 + A1:2007/ EN 60034-14:2004 + A1:2007/
 EN 60204-1:2018 and EN IEC 60204-11:2019**

CE marking in: **1998**

* Electric motors designed for use with a voltage rating higher than 1000V are not considered under the scope.

** Low voltage electric motors are not considered under the scope and electric motors designed for use with a voltage rating higher than 1000V are considered partly completed machinery and are supplied with a

Declaration of Incorporation:

The products above cannot be put into service until the machinery into which they have been incorporated has been declared in conformity with the Machinery Directive.

A Technical Documentation for the products above is compiled in accordance with part B of annex VII of Machinery Directive 2006/42/EC.

We undertake to transmit, in response to a reasoned request by the national authorities, relevant information on the partly completed machinery identified above through WEG authorised representative established in the European Union. The method of transmission shall be electronic or physical method and shall be without prejudice to the intellectual property rights of the manufacturer.

Signed for and on behalf of the manufacturer:
Rodrigo Fumo Fernandes
 Engineering director

Jaraguá do Sul, April 14th, 2022

DEC3222-Rev00 - English 1/1

12 ENVIRONMENTAL INFORMATION

12.1 PACKAGE

Electric motors are supplied in cardboard, polymer, wood or metallic material packages. These materials are recyclable or reusable and must be properly disposed according to the current regulations of each country. All the wood used in the packaging of WEG motors comes from reforestation and receives anti-fungal treatment.

12.2 PRODUCT

Electric motors, under the constructive aspect, are manufactured mainly with ferrous metals (steel, cast iron), nonferrous metals (copper, aluminum) and plastic. The electric motor, in general, is a product that has a long useful life; however, when it must be disposed, WEG recommends that the materials of the packaging and of the product be properly separated and sent for recycling.

The non-recyclable materials must be properly disposed according to the environmental regulations, i.e., in industrial landfill, co-processed in cement kilns or incinerated. The service providers for recycling, disposal in industrial landfills, co-processing or incineration of waste must be properly licensed by the environmental agency of each state to carry out these activities.

12.3 HAZARDOUS WASTE

Grease and oil waste used to lubricate the bearings should be disposed, according to the instructions of the relevant environmental agencies, because its improper disposal can cause impacts to the environment.

13 SERVICE NETWORK

To consult the Service Network, access the website www.weg.net.

14 WARRANTY TERMS

These products, when operated under the conditions stipulated by WEG in the operating manual for such product, are warranted against defects in workmanship and materials for twelve (12) months from start-up date or eighteen (18) months from manufacturer shipment date, whichever occurs first.

However, this warranty does not apply to any product which has been subject to misuse, misapplication, neglect (including without limitation, inadequate maintenance, accident, improper installation, modification, adjustment, repair or any other cases originated from inadequate applications).

The company will neither be responsible for any expenses incurred in installation, removal from service, consequential expenses such as financial losses nor transportation costs as well as tickets and accommodation expenses of a technician when this is requested by the customer.

The repair and/or replacement of parts or components, when effected by WEG within the Warranty period do not give Warranty extension, unless otherwise expressed in writing by WEG.

This constitutes WEG's only warranty in connection with this sale and is in lieu of all other warranties, expressed or implied, written or oral.

There are no implied warranties of merchantability or fitness for a particular purpose that apply to this sale.

No employee, agent, dealer, repair shop or other person is authorized to give any warranties on behalf of WEG nor to assume for WEG any other liability in connection with any of its products.

In case this happens without WEG's authorization, Warranty is automatically cancelled.

LIABILITY

Except as specified in the foregoing paragraph entitled "Warranty Terms for Engineering Products", the company shall have no obligation or liability whatsoever to the purchaser, including, without limitation, any claims for consequential damages or labor costs, by reason of any breach of the express warranty described therein.

The purchaser further hereby agrees to indemnify and hold the company harmless from any causes of action (other than cost of replacing or repairing the defective product as specified in the foregoing paragraph entitled "Warranty Terms for Engineering Products"), arising directly or indirectly from the acts, omissions or negligence of the purchaser in connection with or arising out of the testing, use, operation, replacement or repair of any product described in this quotation and sold or furnished by the company to the purchaser.



WEG Equipamentos Elétricos S.A.
International Division
Av. Prefeito Waldemar Grubba, 3000
89256-900 - Jaraguá do Sul - SC - Brazil
Phone: 55 (47) 3276-4002
Fax: 55 (47) 3276-4060
www.weg.net



+55 47 3276.4000



energia@weg.net



Jaraguá do Sul - SC - Brazil