

Installation Instruction



FLANGE, OPERATING HANDLE (FHU ACW800)

- ▣ Be sure to read the instruction manual and safety precautions before use products.
- ▣ This manual should be given to the person who use products and maintain them.

SAFETY PRECAUTIONS

- ▣ Before installation, wiring, operation, maintenance or inspection of the device, be sure to read the warning message carefully and ensure proper operation.
- ▣ Please follow the instructions, they are very important.
- * In this instruction, level of danger is classified by

- ⚠ **DANGER** It may result in death or serious injury.
- ⚠ **CAUTION** It may result in injury or physical damage.

⚠ DANGER

* Turn off the power before mounting, withdrawing, wiring, maintenance or inspection.
Failure to do it may result in electric shocks and burns.

⚠ CAUTION

1. Do not use deformed or damaged MCCB or operating handle.
2. Mounting, removal, wiring, maintenance and checking should be done by authorized or certified personnel.
3. Operating handle should not be used in severe environment such as high temperature, humidity, dusty, corrosive gas and excessive vibration.
4. Mounting should be done according to the instruction manual. Mistakes on mounting may be a cause for a ACW and operation handle or cause an accident such as operator do himself an injury.

1. INSTALLATION INSTRUCTION

1. Turn off and lock out all power supplying the circuit breaker and all other equipment within the enclosure before installing.
2. Determine mounting location for the handle and circuit breaker. See Figure. 1 and Tables 1 and 2.
3. The handle can be mounted on right side of flange type enclosures.
4. A latch is provided for applications where no interlocking door latch mechanism is provided.
5. The PLATE ASS'Y BASE FH-1 mounts to the circuit breaker and can be padlocked in the "OFF" position.

NOTE : THE MINIMUM BEND RADIUS FOR THE CABLE IS THREE & ONE-HALF (3-1/2) INCHES.
Prepare the mounting holes for the handle and circuit breaker and remove burrs.

2. HANDLE INSTALLATION-See Figures 3 and 4.

1. Secure O-RING into handle groove. Mount handle and frame to the enclosure flange using the two M6X18 (+)PH, P/W screws. Tighten screws to 75 in-lbs.
2. Place the PLATE FLANGE LINK onto the LINK CONNECTION PIN and secure with the E-ring, D8.
3. Attach the PLATE LOCK LINK to the PLATE LOCK FLANGE using the M6X10 screw. Tighten nuts to 25 in-lbs.
4. Close the enclosure door. This should release the PLATE LOCK LINK allowing the handle to be turned ON. If the handle cannot be turned ON, adjust PLATE HOOK LOCK downward in its slot and repeat item 4.
5. Turn handle ON and attempt to open door. The PLATE LOCK LINK should hold the door closed. If the door can be opened, readjust the PLATE HOOK LOCK upward in its slot. Repeat steps 3 and 4 to insure that the door can not be opened when the handle is in the ON position.

Figure. 1 and 2 shows the location of the handle and door catch when mounted on the enclosure.

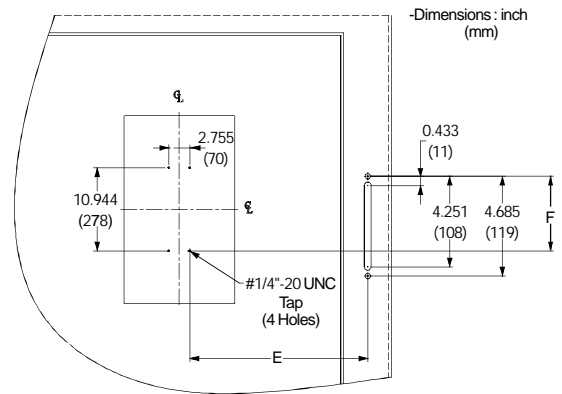

<Fig. 1>

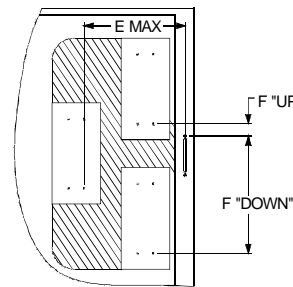

<Fig. 2>

ENCLOSURE DEPTH	MAXIMUM "E" DIMENSION	
	FHU-60	FHU-72
10	25	30
12	24	29
16	23	28
18	22	27
20	21	26
24	20	25
30	19	24
36	18	23

Dimensions : inch

ENCLOSURE DEPTH	MAXIMUM "F" DIMENSION			
	62 cable		72 cable	
	UP	DOWN	UP	DOWN
10	17	31	20	34
12	17	31	19	33
16	17	28	19	30
18	17	28	19	30
20	16	26	18	28
24	14	26	16	28
30	11	24	13	26
36	6	21	8	22

Dimensions : inch

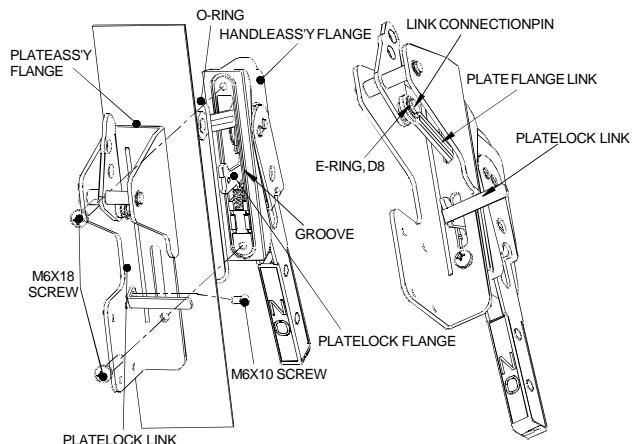

<Fig. 3>

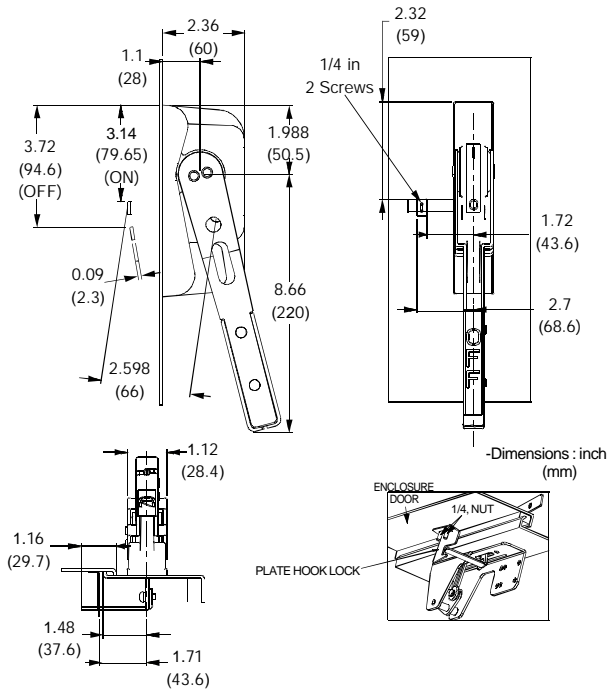

<Fig. 4>

3. BREAKER AND BREAKER OPERATOR INSTALLATION-See Figure. 5

1. Turn the circuit breaker ON.
2. Attach circuit breaker and PLATE ASS'Y,BASE FHU to the back panel using four N°.1/4"-20 UNC screws as shown at Figure 5. Tighten screws to 150 in-lbs.
3. Attach the PLATE FIXED CABLE TO PLATE ASS'Y BASE FH3 using M5x10 screw. Tighten screws to 25 in-lbs.

* DANGER- Confirm that suppling power has been turned off.
 * CAUTION-DON'T PUSH TRIP BUTTON WITH FINGERS.

4. CABLE INSTALLATION - See Figure. 6

1. Secure cable to PLATE ASS'Y FLANGE with HOLDER FLANGE CABLE using M5X10 screws. Tighten screws to 75 in-lbs. HOLDER FLANGE CABLE must interlock with groove in cable.
2. Move handle to OFF position and pull cable to it's maximum stroke Shim cable connecting and attach into hole of LINK ASS'Y. Secure with E-ring.
3. Attach end of cable to PLATE ASS'Y BASE FHU as described below.
 NOTE: To ensure proper adjustment and to prevent possible damage to the operator, Follow the remaining steps carefully.
4. Move the handle to it's maximum ON position.
5. Adjust the top cable mounting nut to M5 from start of cable thread as shown in Detail A.
6. Insert end of the cable rod through the hole in the PLATE BAR TAB And place the cable mounting threads into the slotted FIXED TAB PLATE of the PLATE ASS'Y BASE FHU. Tight cable mounting nut (M12) And adjustment nut (M12) until the cable is secured to the tab.
7. After install the mounting nut and adjustment nut. Handle is maximum On position.

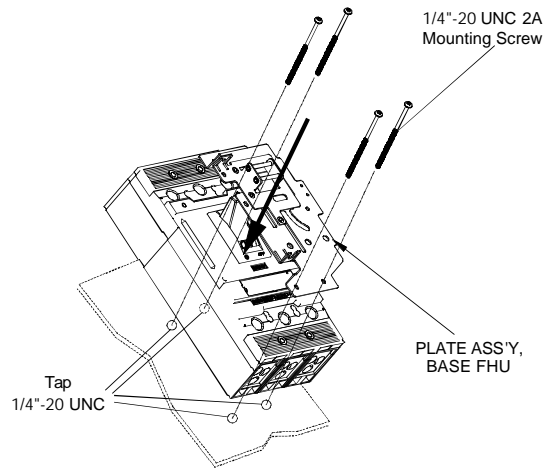

<Fig. 5>

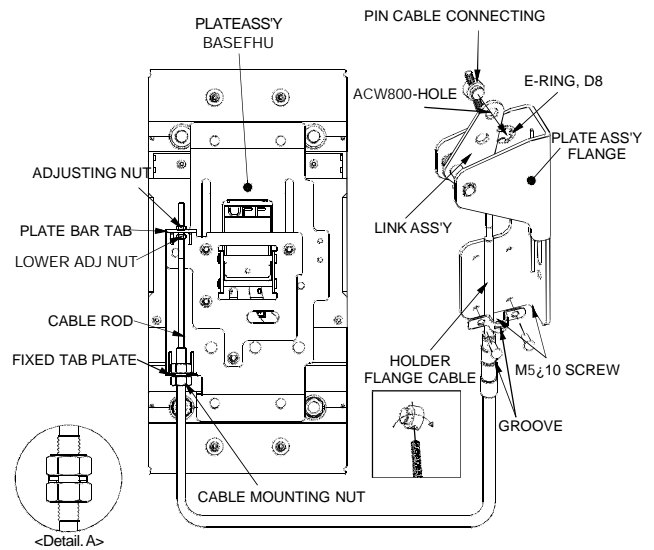

<Fig. 6>

5. CABLE ADJUSTMENT

1. Check that the circuit breaker turns OFF and ON by moving the operating handle. If circuit breaker does not turn ON, loosen adjusting nut and tight lower adj nut to PLATE BAR TAB. Repeat if required.
2. Turn the circuit breaker ON and trip it by pushing the "trip" button (not using your finger).
3. If the circuit breaker does not reset, loose the lower adj nut and tight adjusting nut to PLATE BAR TAB. Repeat if required.

* DANGER- Confirm that suppling power has been turned off.
 * CAUTION-DON'T PUSH TRIP BUTTON WITH FINGERS.

