



**GARANTIA / WARRANTY / GARANTÍA /
GÄHRLEISTUNG:**

A WEG oferece garantia limitada contra defeitos de fabricação ou de materiais de seus produtos. Para mais informações acesse nosso site:
WEG provides a limited warranty for its products against defects in materials and workmanship. For more information access our site:
WEG ofrece garantía limitada contra defectos de fabricación o de materiales de sus productos. Para más informaciones acceda al WEG sitio:
WEG bietet eine beschränkte Gewährleistung für ihre Produkte gegen Herstellungs- und Materialfehler. Für weitere Informationen besuchen Sie bitte unsere Webseite:
www.weg.net/warranty-automation

ATENÇÃO:

- Desconecte da rede elétrica antes de proceder qualquer trabalho neste equipamento.
- Somente profissionais qualificados podem efetuar a instalação e manutenção.
- Obedeçam normas nacionais, estaduais, locais e instruções de operação.

WARNING:

- Disconnect power before proceeding with any work on this equipment.
- Installation and maintenance by technical personnel only.
- Attend the national, regional and local standards and follow the operating instruction.

ATENCIÓN:

- Desconectar de la red eléctrica antes de hacer cualquier trabajo en este equipamiento.
- Recomendase instalación por profesional calificado.
- Respetar normas nacionales y locales.
- Producto destinado a utilización en instalaciones eléctricas de baja tensión.

WARNUNG:

- Bevor irgend eine Arbeit am Gerät vorgenommen wird, muss sichergestellt sein, dass die Einheit stromlos und freigeschaltet ist.
- Sämtliche Arbeiten an der Einheit dürfen daher ausschließlich nur von Fachpersonal vorgenommen werden.
- Die jeweils geltenden nationalen, örtlichen und anlagenspezifischen Bestimmungen und Erfordernisse sind zu berücksichtigen.

10002458130.09
WEG Automação
www.weg.net

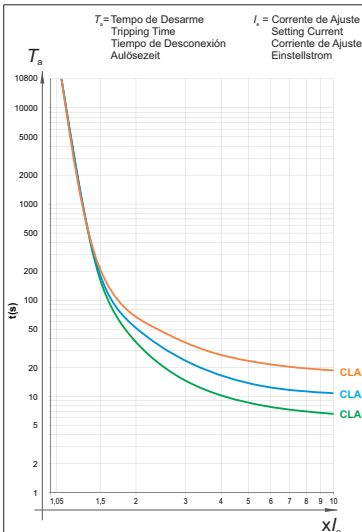
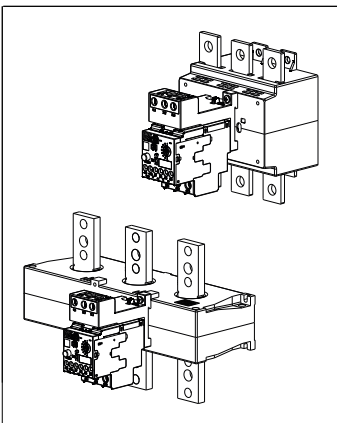

As curvas representadas são típicas, baseadas na norma IEC 60947-4-1.
The curves shown are typical, based on IEC 60947-4-1.
Las curvas representadas son típicas, baseadas en la norma IEC 60947-4-1.
Die dargestellten Kurven sind typisch, basierend auf IEC 60947-4-1.

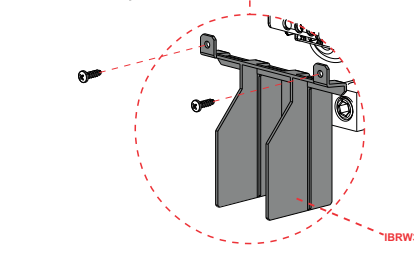
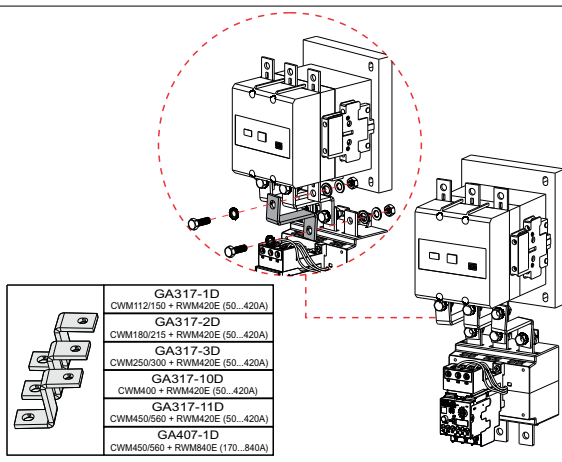
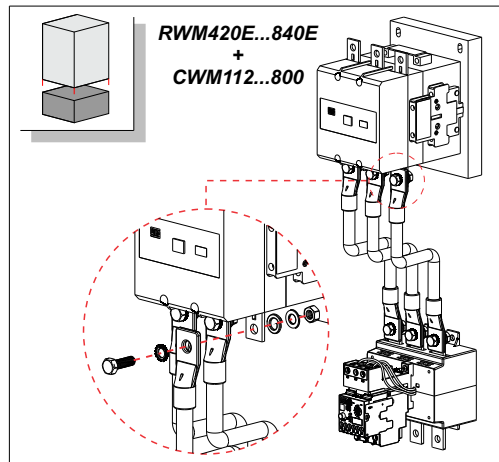
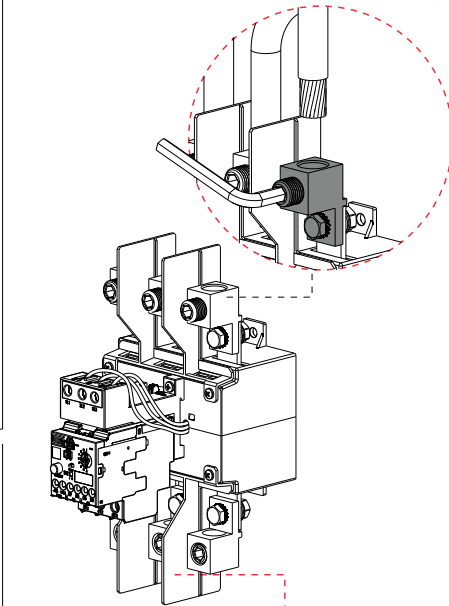
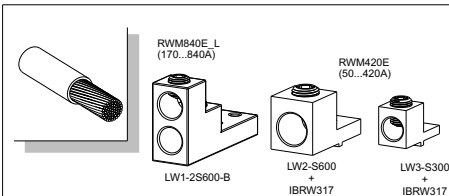

IBRW317

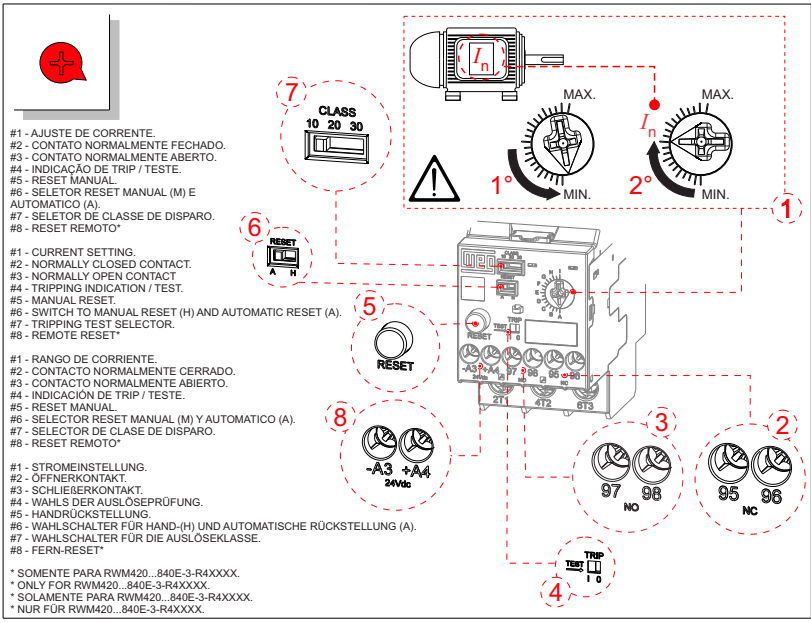
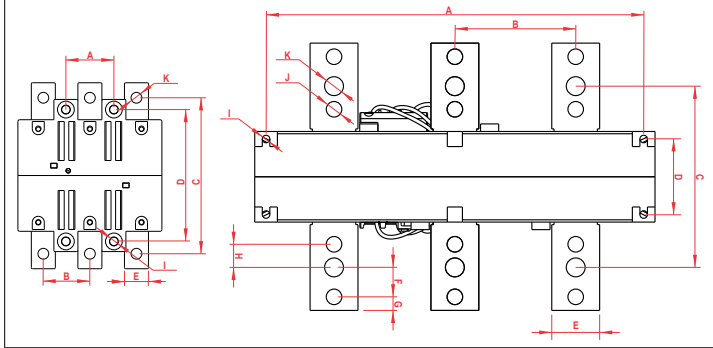
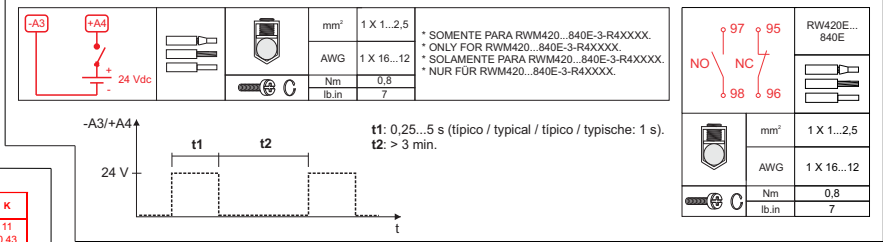
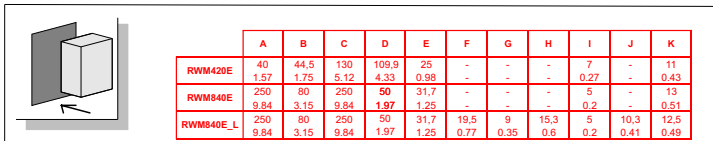
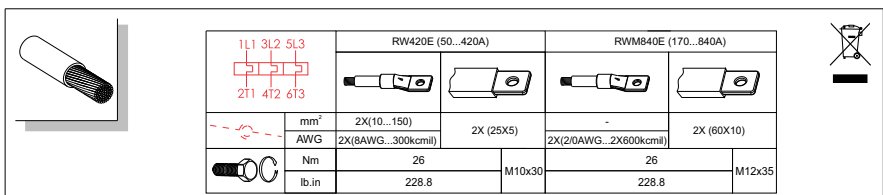
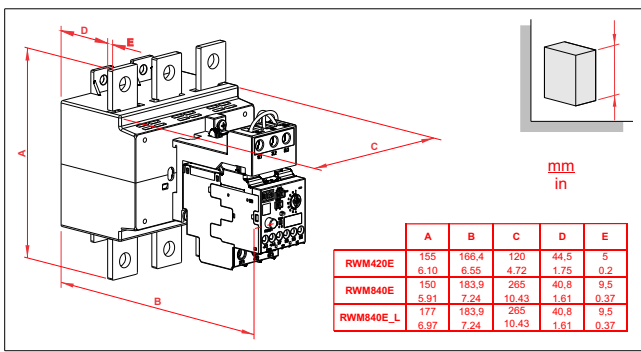

WEG IMPORTERS IN THE EUROPEAN UNION
AUSTRIA - WATT DRIVE ANTRIEBSTECHNIK GMBH - Wöllersdorfer Str. 68, 2753 Markt Piesting, Wiener, Austria; **BELGIUM** - WEG BENELUX S.A. - Rue de l'Industrie 30/D, 1400 Nivelles, Belgium; **FRANCE** - WEG FRANCE SAS - 13 Rue du Morellon, 38297 Saint Quentin Fallavier, France; **GERMANY** - WEG GERMANY GMBH - Geigerstraße 7, 50169 Industriegebiet Tünnich 3, Kerpen, Germany; **ITALY** - WEG ITALIA S.R.L. - Via Viganò de Vizzi, 93/95, 20092 Cinesello Balsamo, Milano, Italy; **NETHERLANDS** - WEG NETHERLANDS - Hanzepoort 23C, 7575 DB Oldenzaal, Netherlands; **PORTUGAL** - WEG EURO-INDUSTRIA ELECTRICA S.A. - R. Eng. Frederico Ulrich 605, 4471-908 Maia, Portugal; **SPAIN** - WEG IBERIA INDUSTRIAL S.L. - C/ Tierra de Barros, 5-7, 28823 Coslada, Madrid, Spain; **SCANDINAVIA** - WEG SCANDINAVIA AB - Box 27, 435 21, 43533 Mölninge, Sweden; **UNITED KINGDOM** - WEG (UK) LTD - Broad Ground Road, Redditch B988YP, Worcestershire, United Kingdom.
 Information valid for WEG Group Importers.