

CPTW Series

Control Power Transformers

Compact and Economical Solutions



www.weg.net | 1-800-ASK-4WEG

VOLTAGE TABLE

VA	Primary Voltage	Secondary Voltage	Part Number
3000	220 x 440, 230 x 460, 240 x 480	110, 115, 120	CPTW3K0-ASC
Max Depth	Max Width	Max Height	Mounting Depth
7.82"	9.00"	7.62"	4.25"
Mounting Width	Mounting Hole Depth	Mounting Hole Width	Phase
6.50"	0.44"	1.00"	1
Frequency	Shipping Weight	Voltage Group	
50/60 Hz	53.0 lbs.	A	

WEG

WEG is a leader in the design and manufacturing of electrical equipment for industrial, commercial and utility applications. Our products are designed to provide reliable, efficient and safe solutions for your specific needs. We are committed to providing the highest quality products and services to our customers.

DIAGRAM

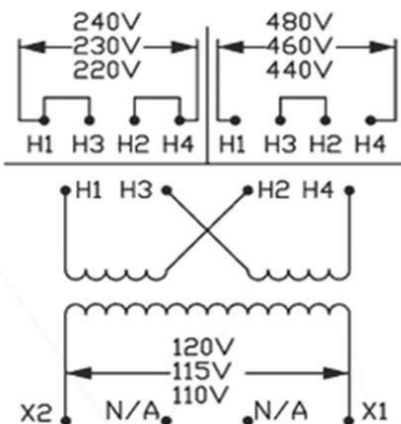

SPECIFICATIONS

- Class 180°C (356°F) insulation system with 115°C (239°F) temperature rise.
- All transformers up to 750VA come with pre-installed secondary fuse kits, ready to accept 13/32" x 1 1/2" midget or Class CC fuses.
- Two parallel jumper links come standard with transformers with dual primary voltages.
- All transformers up to 3kVA include a built-in mounting adapter for fuse blocks.