

WEG Molded Case Circuit Breakers

UBW225

User's Manual

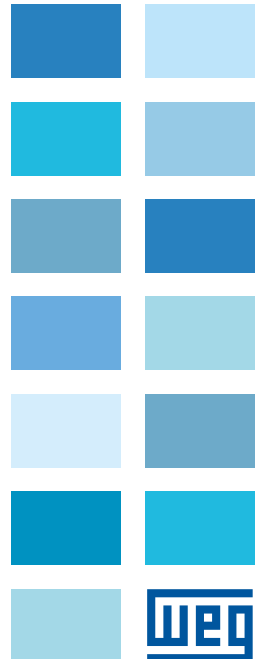
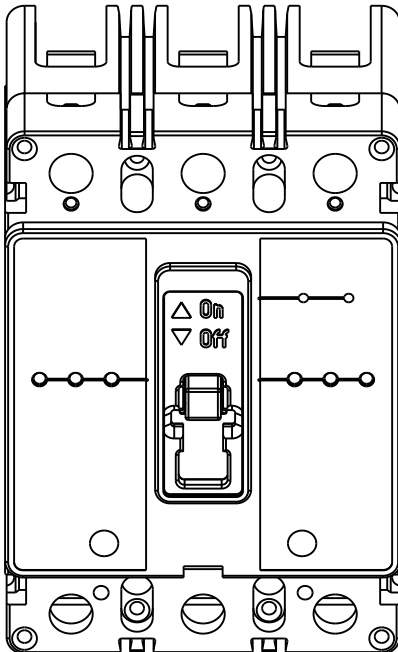

**WARNING**

- Do not attempt to install or perform maintenance on equipment while it is energized. Death, severe personal injury or substantial property damage can result from contact with energized equipment. Always verify that no voltage is present before proceeding with the task, and always follow generally accepted safety procedures.
- WEG is not liable for the misapplication or misinstallation of its products.

The user is cautioned to observe all recommendations, warnings and cautions relating to the safety of personnel and equipment, as well as all general and local health and safety laws, codes and procedures.

The recommendations and information contained herein are based on WEG experience and judgment, but should not be considered to be all-inclusive or covering every application or circumstance which may arise. If any questions arise, contact WEG for further information or instructions.

1. INTRODUCTION

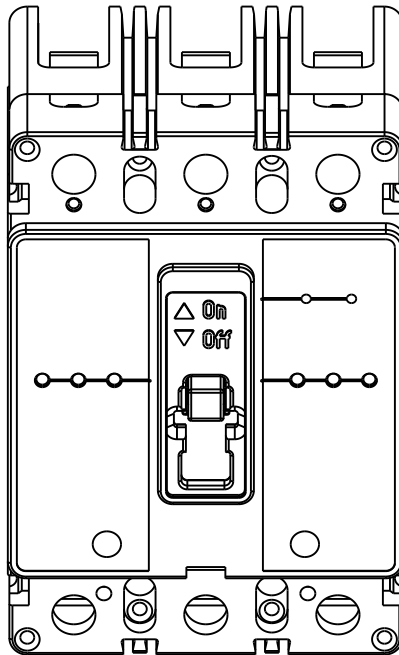

Figure 1: UBW225 circuit breaker and molded case switches

The UBW225 circuit breakers (Figure 1) are rated from 15 A to 225 A continuous current thermal-magnetic circuit breakers. Circuit breakers are listed in accordance with Underwriters Laboratories, Inc. Standard UL 489, and satisfy the (P1) requirements of the International Electrotechnical Commission Recommendation No. IEC 157-1.

2. INSTALLATION

The installation procedure consists of inspecting and mounting the circuit breaker, connecting and torquing the line and load terminations, and attaching terminal shields or barriers, when supplied. To install the circuit breaker perform the following steps:

Note: the UBW225 circuit breakers are factory sealed. UL 489 requires that internal accessories be installed at the factory. Where local codes and standards permit and UL listing is not required, internal accessories can be field installed. Accessory installation should be done before the circuit breaker is mounted and connected.

Mounting hardware and unmounted terminations (where required) are supplied in separate packages.

1. Make sure that the circuit breaker is suitable for the installation by comparing nameplate data with system requirements. Inspect the circuit breaker for completeness and check for damage before mounting.



WARNING

- Before mounting the circuit breaker in an electrical system, make sure there is no voltage present where work is to be performed. The voltages in energized equipment can cause injury or death.

2. Depending on the equipment configuration the circuit breaker can be mounted using different styles of hardware. The following steps describe how to mount the circuit breaker using standard hardware. When special hardware is needed (for example, with the electrical operator), the instruction leaflet describing the accessory also describes the special mounting arrangements.

Note: before mounting the circuit breaker, check if the termination devices should be installed first. See terminations instructions.

3. To mount the circuit breaker, perform the following steps:
 - a. For individual mounting panels, make sure that mounting panel is predrilled using bolt drilling plan (Figure 2). For panelboard mounting, only load end support mounting holes are required. For deadfront cover applications make sure panel cover is cut out to correct escutcheon dimensions (Figure 3).

**CAUTION**

- Do not exceed connector/bus capacity in WEG power line.

- If circuit breaker includes factory installed internal accessories, make sure accessory wiring can be reached when the circuit breaker is mounted.
- Position circuit breaker on mounting surface.
- Install mounting screws, washers, and nuts. Tighten screws firmly, but do not exceed 28 pound-inches (3.16 N.m).

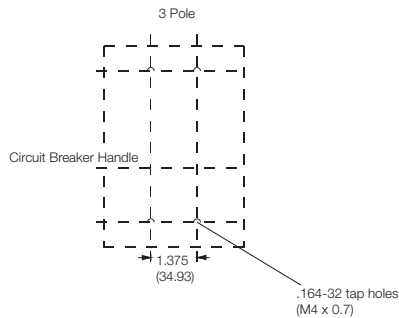

Figure 2: circuit breaker mounting bolt drilling plans

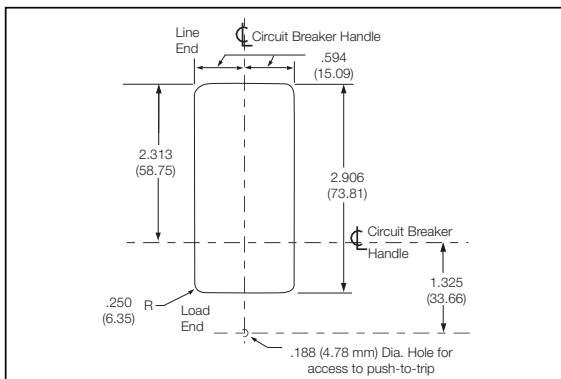

Figure 3: circuit breaker escutcheon dimensions

- If an optional terminal end cover is to be installed with the circuit breaker (usually line end only), it must be positioned before cable is connected to terminals.

CAUTION

- When aluminum conductors are used, the application of a suitable joint compound is recommended to reduce the possibility of terminal overheating. Terminal overheating can cause nuisance tripping and damage to the circuit breaker.

- After mounting the circuit breaker, line and load terminals and accessory leads should be connected (see accessory schematic diagram on side of circuit breaker.)

Note: if terminal shield or interphase barriers are to be installed on the circuit breaker, install them after the terminals are connected.

- If required, install terminal shield on circuit breaker cover with mounting screws provided.
- If required, install an interphase barrier by sliding barrier into dovetail grooves between terminals.
- After the circuit breaker is installed, check all mounting hardware and terminal connecting hardware for correct torque loading. Torque values for line/load terminals are given in Tables 1, 2, and 3 and on the circuit breaker nameplate.

Note: see Section 5 for additional details for HFDDC.

| Terminal catalog number | Terminal body material | Screw head type | AWG wire range | Metric wire range | Wire type | Torque value, Lb. in.(N.m) |
|--------------------------|------------------------|-----------------|----------------|-------------------|-----------|----------------------------|
| LT3 UBW225 ¹⁾ | Aluminum | 3/16 socket hex | #4-4/0 | 25-95 | Cu/Al | 120 (13.6) |
| WT3 UBW225 | Aluminum | 5/32 socket hex | #14-2 | 25-95 | Cu/Al | 70 (7.9) |
| WT6 UBW225 | Aluminum | 3/32 socket hex | #14-6 | 2.5-10 | Cu/Al | 25 (2.8) |

Table 1: terminal types

Note: 1) Package of three.

| Metric wire range | Torque value N.m | AWG wire range | Torque value, Lb.-In. |
|-------------------|------------------|----------------|-----------------------|
| 2.5-6 | 3.96 | #14-#10 | 35 |
| 10 | 4.52 | #8 | 40 |
| 16-25 | 5.09 | #6-#4 | 45 |
| 35-95 | 5.65 | #3-4/0 | 50 |

Table 2: terminal torque values for slotted head

3. MANUAL OPERATION

Manual operation of the circuit breaker is controlled by the circuit breaker handle and the PUSH-TO-TRIP button. The circuit breaker handle has three indicated positions, two of which are shown on the cover with raised lettering to indicate ON and OFF. On the sliding handle barrier, ON, OFF, and trip are also shown by a color-coded strip for each circuit breaker handle position: red for ON, white for tripped, and green for OFF. On the sliding handle barrier, ON/OFF is also shown with the international symbols I/O (see Figure 4.)

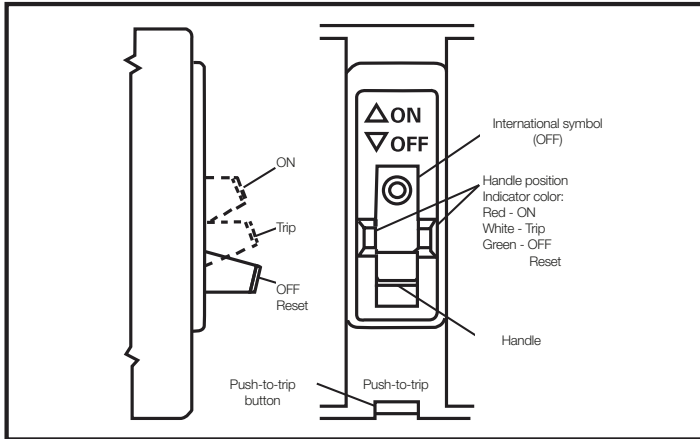

Figure 4: circuit breaker manual controls

3.1. CIRCUIT BREAKER RESET

After tripping, the circuit breaker is reset by moving the circuit breaker handle to the extreme OFF position.

Note: in the event of a thermal trip, the circuit breaker cannot be reset until the thermal element cools.

3.2. PUSH-TO-TRIP BUTTON

The PUSH-TO-TRIP button checks the tripping function and is used to periodically exercise the operating mechanism.

4. INSPECTION AND FIELD TESTING

UBW225 molded case circuit breakers are designed to provide years of almost maintenance-free operation. The following procedure describes how to inspect and test a circuit breaker in service.

4.1. INSPECTION

Circuit breakers in service should be inspected periodically. The inspection should include the following checks 1 thru 7.



WARNING

- Before inspecting the circuit breaker in an electrical system, make sure the circuit breaker is switched to the off position and there is no voltage present where work is to be performed. Special attention should be paid to reverse feed applications to ensure no voltage is present. The voltages in energized equipment can cause injury or death.



CAUTION

- Make sure that cleaning agents or solvents used to clean the circuit breaker are suitable for the job. Some commercial cleaning agents will damage the name plates or molded parts.

1. Remove dust, dirt, soot, grease, or moisture from the surface of the circuit breaker using a lint-free dry cloth, brush, or vacuum cleaner. Do not blow debris into circuit breaker. If contamination is found, look for the source and eliminate the problem.
2. Switch circuit breaker to ON and OFF several times to be sure that the mechanical linkages are free and do not bind. If mechanical linkages are not free, replace circuit breaker.
3. Press the PUSH-TO-TRIP button to mechanically trip the circuit breaker. Trip, reset, and switch circuit breaker ON several times. If mechanism does not reset each time the circuit breaker is tripped, replace the circuit.
4. Check base, cover, and operating handle for cracks, chipping, and discoloration. Circuit breakers should be replaced if cracks or severe discoloration is found.
5. Check terminals and connectors for looseness or signs of over-heating. Overheating will show as discoloration, melting, or blistering of conductor insulation, or as pitting or melting of conductor surfaces due to arcing. If there is no evidence of overheating or looseness, do not disturb or tighten the connections. If there is evidence of overheating, terminations should be cleaned or replaced. Before re-energizing the circuit breaker, all terminations and cable should be refurbished to the condition when originally installed.
6. Check circuit breaker mounting hardware. Tighten if necessary.
7. Check area where circuit breaker is installed for any safety hazards, including personal safety and fire hazards. Exposure to certain types of chemicals can cause deterioration of electrical connections.

4.2. FIELD TESTING

Any field testing should be done in accordance with applicable NEMA Standards.

5. HFDDC

The instructions for installation, testing, maintenance, or repair herein are provided for the use of the product in general commercial applications and may not be appropriate for use in nuclear applications. Additional instructions may be available upon specific request to replace, amend, or supplement these instructions to qualify them for use with the product in safety-related applications in a nuclear facility.

The information, recommendations, descriptions, and safety notations in this document are based on WEG's experience and judgment with respect to Retrofitting of Power Breakers. This instructional literature is published solely for information purposes and should not be considered all-inclusive. If further information is required, you should consult an authorized WEG sales representative. The sale of the product shown in this literature is subject to the terms and conditions outlined in appropriate WEG selling policies or other contractual agreement between the parties. This literature is not intended to and does not enlarge or add to any such contract. The sole source governing the rights and remedies of any purchaser of this equipment is the contract between the purchaser and WEG.

NO WARRANTIES, EXPRESSED OR IMPLIED, INCLUDING WARRANTIES OF FITNESS FOR A PARTICULAR PURPOSE OR MERCHANTABILITY, OR WARRANTIES ARISING FROM COURSE OF DEALING OR USAGE OF TRADE, ARE MADE REGARDING THE INFORMATION, RECOMMENDATIONS, AND DESCRIPTIONS CONTAINED HEREIN. In no event will WEG be responsible to the purchaser or user in contract, in tort (including negligence), strict liability or otherwise for any special, indirect, incidental or consequential damage or loss whatsoever, including but not limited to damage or loss of use of equipment, plant or power system, cost of capital, loss of power, additional expenses in the use of existing power facilities, or claims against the purchaser or user by its customers resulting from the use of the information, recommendations and description contained herein.

WEG Worldwide Operations

ARGENTINA

San Francisco - Cordoba
Phone: +54 3564 421484
info-ar@weg.net

Cordoba - Cordoba
Phone: +54 351 4641366
weg-morbe@weg.com.ar

Buenos Aires
Phone: +54 11 42998000
ventas@pulverlux.com.ar

AUSTRALIA

Scoresby - Victoria
Phone: +61 3 97654600
info-au@weg.net

AUSTRIA

Markt Piesting - Wiener
Neustadt-Land
Phone: +43 2633 4040
watt@wattdrive.com

BELGIUM

Nivelles - Belgium
Phone: +32 67 888420
info-be@weg.net

BRAZIL

Jaraguá do Sul - Santa
Catarina
Phone: +55 47 32764000
info-br@weg.net

CHILE

La Reina - Santiago
Phone: +56 2 27848900
info-cl@weg.net

CHINA

Nantong - Jiangsu
Phone: +86 513 85989333
info-cn@weg.net

Changzhou - Jiangsu
Phone: +86 519 88067692
info-cn@weg.net

COLOMBIA

San Cayetano - Bogota
Phone: +57 1 4160166
info-co@weg.net

ECUADOR

El Batán - Quito
Phone: +593 2 5144339
ceccato@weg.net

FRANCE

Saint-Quentin-Fallavier - Isère
Phone: +33 4 74991135
info-fr@weg.net

GERMANY

Türnich - Kerpen
Phone: +49 2237 92910
info-de@weg.net

Balingen - Baden-
Württemberg
Phone: +49 7433 90410
info@weg-antriebe.de

GHANA

Accra
Phone: +233 30 2766490
info@zestghana.com.gh

INDIA

Bangalore - Karnataka
Phone: +91 80 41282007
info-in@weg.net

Hosur - Tamil Nadu
Phone: +91 4344 301577
info-in@weg.net

ITALY

Cinisello Balsamo - Milano
Phone: +39 2 61293535
info-it@weg.net

JAPAN

Yokohama - Kanagawa
Phone: +81 45 5503030
info-jp@weg.net

MALAYSIA

Shah Alam - Selangor
Phone: +60 3 78591626
info@wattdrive.com.my

MEXICO

Huehuetoca - Mexico
Phone: +52 55 53214275
info-mx@weg.net

Tizayuca - Hidalgo
Phone: +52 77 97963790

NETHERLANDS

Oldenzaal - Overijssel
Phone: +31 541 571080
info-nl@weg.net

PERU

La Victoria - Lima
Phone: +51 1 2097600
info-pe@weg.net

PORTUGAL

Maia - Porto
Phone: +351 22 9477700
info-pt@weg.net

RUSSIA and CIS

Saint Petersburg
Phone: +7 812 363 2172
sales-wes@weg.net

SOUTH AFRICA

Johannesburg
Phone: +27 11 7236000
info@zest.co.za

SPAIN

Coslada - Madrid
Phone: +34 91 6553008
wegiberia@wegiberia.es

SINGAPORE

Singapore
Phone: +65 68589081
info-sg@weg.net

Singapore
Phone: +65 68622220
watteuro@watteuro.com.sg

SCANDINAVIA

Mölnlycke - Sweden
Phone: +46 31 888000
info-se@weg.net

UK

Redditch - Worcestershire
Phone: +44 1527 513800
info-uk@weg.net

UNITED ARAB EMIRATES

Jebel Ali - Dubai
Phone: +971 4 8130800
info-ae@weg.net

USA

Duluth - Georgia
Phone: +1 678 2492000
info-us@weg.net

Minneapolis - Minnesota
Phone: +1 612 3788000

VENEZUELA

Valencia - Carabobo
Phone: +58 241 8210582
info-ve@weg.net

For those countries where there is not a WEG own operation, find our local distributor at www.weg.net.



WEG Group - Automation Business Unit
Jaraguá do Sul - SC - Brazil
Phone: +55 (47) 3276-4000
automacao@weg.net
www.weg.net

