

Instruction Manual

EXP-IO- SENS-100-ADV

I/O Expansion card

- 2 PT100 Analog Inputs
- 1 Klixon / PTC / KTY84 Input
- 1 Klixon / PTC / KTY84 Output
- 2 Analog Outputs

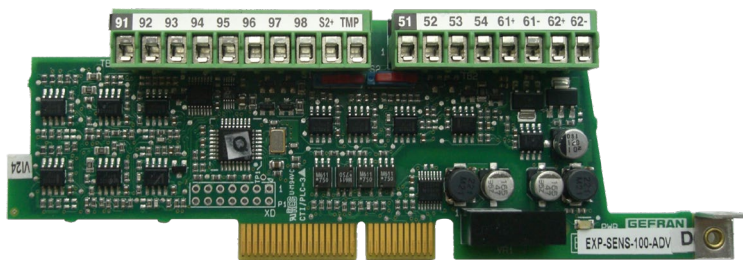

① Drive Requirements

The EXP-IO-SENS-100-ADV card is designed for the following drives:

- Drive Type: ADV200 WA (all versions); Recommended Firmware Release: 1.0 or later.
- Drive Type: ADV200 (all versions); Firmware Release: 7.0 or later.

② Description

The EXP-IO-SENS-100-ADV is an optional expansion card for the ADV200 and ADV200 WA product family. This card enables measurement of ambient temperature values via PT100 external probe, and of motor temperatures via Klixon, PTC or KTY84 external probe. The following I/O terminals are available on the card:

- 2 x Inputs for temperature measurement via PT100 probe (-20°C ÷ 180°C / -4°F ÷ 356°F) or alternately working as 2 x analog inputs for analog measurement (selection via software configuration);
- 1 x Input for temperature measurement via Klixon, PTC or KTY84 probe;
- 1 x Output for Klixon, PTC or KTY84 probe power supply;
- 2 x Analog Outputs.

About the Analog Outputs:

- The analog outputs are manually configurable by means of a dedicated dip switch to select current or voltage mode (see picture in the next paragraph);
- The analog outputs can work in current mode within the range of 0 ÷ 20mA or in voltage mode within the range of 0 ÷ 10V.



NOTE The drive can host one single card.







③ Connections

Card pin out details are shown below:

91	92	93	94	95	96	97	98	S2+	TMP	nu	51	52	53	54	61+	61-	62+	62-
----	----	----	----	----	----	----	----	-----	-----	----	----	----	----	----	-----	-----	-----	-----

Terminal	Name	Function	Max.
91	I-source Thermistor 1	Output current Thermistor 1	DO NOT CONNECT CURRENT OR VOLTAGE SOURCE (max 11V@1.3mA)
92	V+ Thermistor 1	Positive Input Voltage Thermistor 1	DO NOT CONNECT CURRENT OR VOLTAGE SOURCE (max 12V)
93	V- Thermistor 1	Negative Input Voltage Thermistor 1	DO NOT CONNECT CURRENT OR VOLTAGE SOURCE (max 12V)
94	I-sink Thermistor 1	Input current Thermistor 1	DO NOT CONNECT CURRENT OR VOLTAGE SOURCE (max 11V@-1.1mA)
95	I-source Thermistor 2	Output current Thermistor 2	DO NOT CONNECT CURRENT OR VOLTAGE SOURCE (max 11V@1.3mA)
96	V+ Thermistor 2	Positive Input Voltage Thermistor 2	DO NOT CONNECT CURRENT OR VOLTAGE SOURCE (max 12V)
97	V- Thermistor 2	Negative Input Voltage Thermistor 2	DO NOT CONNECT CURRENT OR VOLTAGE SOURCE (max 12V)
98	I-sink Thermistor 2	Input current Thermistor 2	DO NOT CONNECT CURRENT OR VOLTAGE SOURCE (max 11V@-1.3mA)
S2+	Power supply Klixon, PTC, KTY84	Output Power supply @ 10V limited in current to the sensors.	Max 7mA@10.1V
TMP	Measurement sensor Klixon, PTC, KTY84	Input for temperature measurement (PTC or KTY84) or switch for Klixon.	DO NOT CONNECT CURRENT OR VOLTAGE SOURCE (max 12V)
nu	NOT USED		
51	V1+ or I1+ measurement	Positive Analog Input 1 for Voltage measurement 0-10V or current measurement 0-20mA	Max 12V/24mA
52	V1- or I1- measurement	Negative Analog Input 1 for Voltage measurement 0-10V or current measurement 0-20mA	Max 12V/24mA
53	V2+ or I2+ measurement	Positive Analog Input 2 for Voltage measurement 0-10V or current measurement 0-20mA	Max 12V/24mA
54	V2- or I2- measurement	Negative Analog Input 2 for Voltage measurement 0-10V or current measurement 0-20mA	Max 12V/24mA
61+	Analog Output 1	Positive Analog Output 1 for Voltage 0-10V or current 0-20mA	DO NOT CONNECT CURRENT OR VOLTAGE SOURCE (max 11V@21mA)
61-	Analog Output 1	Negative Analog Output 1 for Voltage 0-10V or current 0-20mA	DO NOT CONNECT CURRENT OR VOLTAGE SOURCE (max 11V@-21mA)
62+	Analog Output 2	Positive Analog Output 2 for Voltage 0-10V or current 0-20mA	DO NOT CONNECT CURRENT OR VOLTAGE SOURCE (max 11V@21mA)
62-	Analog Output 2	Negative Analog Output 2 for Voltage 0-10V or current 0-20mA	DO NOT CONNECT CURRENT OR VOLTAGE SOURCE (max 11V@-21mA)

Analog Output 1 and 2 dip-switches for voltage or current selection:

		
S1	 V  I	<p>Channel 1 analog output factory-configured for output 0 – 10V</p>
S2	 V  I	<p>Channel 2 analog output factory-configured for output 0 – 10V</p>

4 Functional Block Diagram

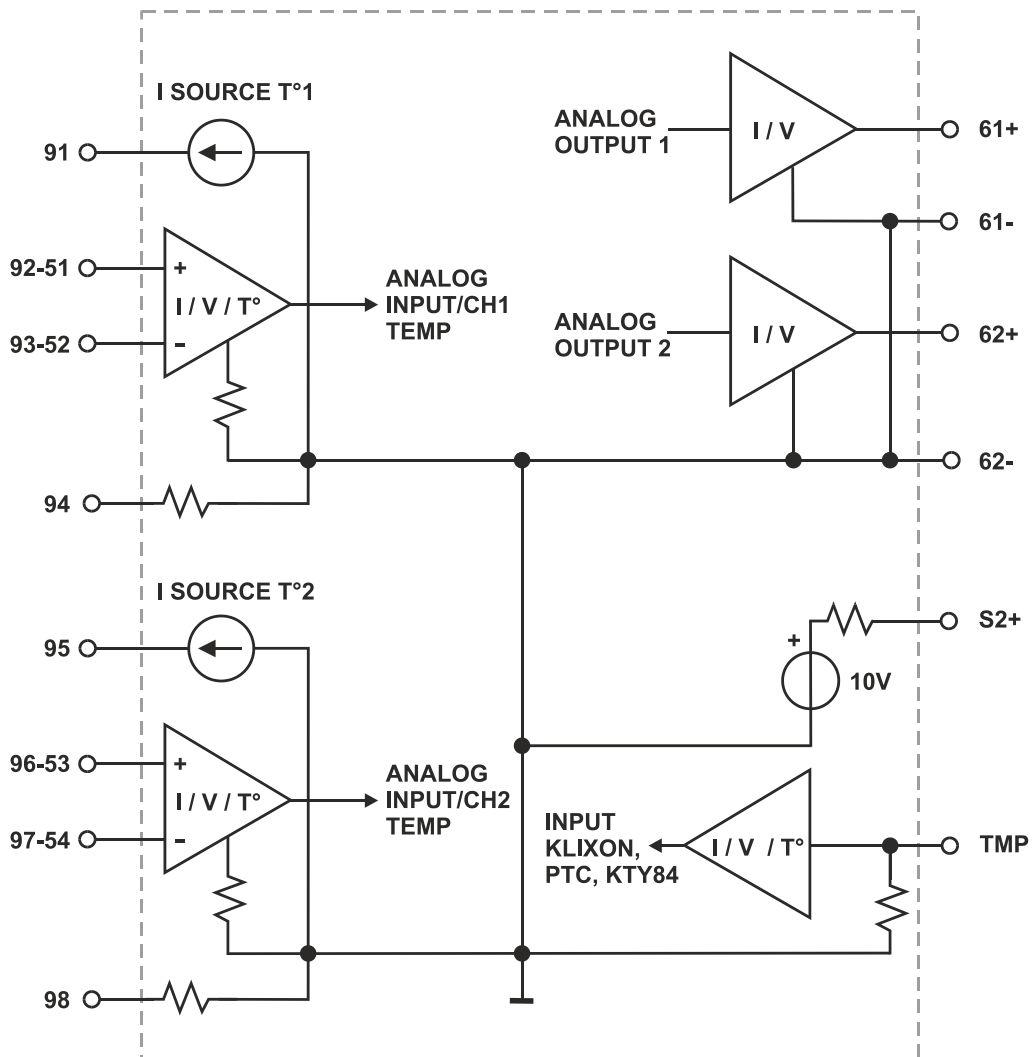

Note:

Terminals 92-93 and 96-97 can be used as ANALOG INPUT

Terminals 51-52 and 53-54 can be used as TEMPERATURE SENSOR INPUT

5 Probe Wiring Diagrams

This section describes the wiring schema for connecting thermistors, RTD and sensors with reference to the most frequently used configuration. If the distance between the probe and the drive is longer than 3 meters (9.84 feet) 4-wire configuration is advisable.

- **PT-100 2-wire connection:**

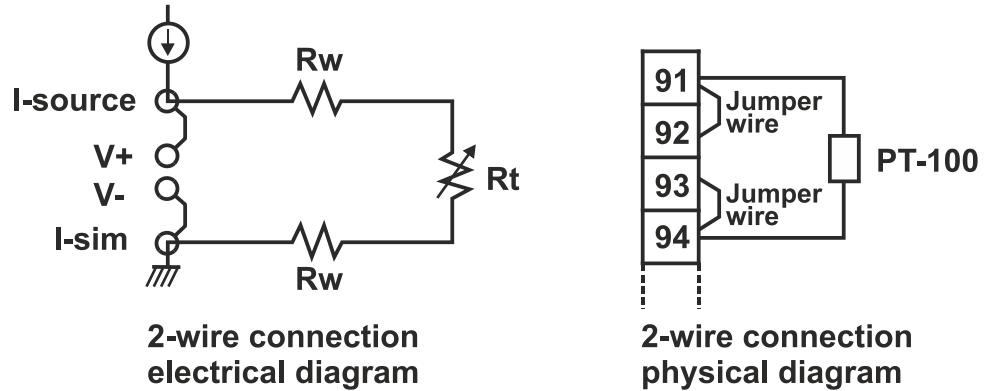

where R_w is the resistance of the wire and R_t is the resistance of the probe. Use shielded cables to connect the PT-100 to the card and shortcut the shield to the metal cover of the drive (System Ground).

- **PT-100 3-wire connection:**

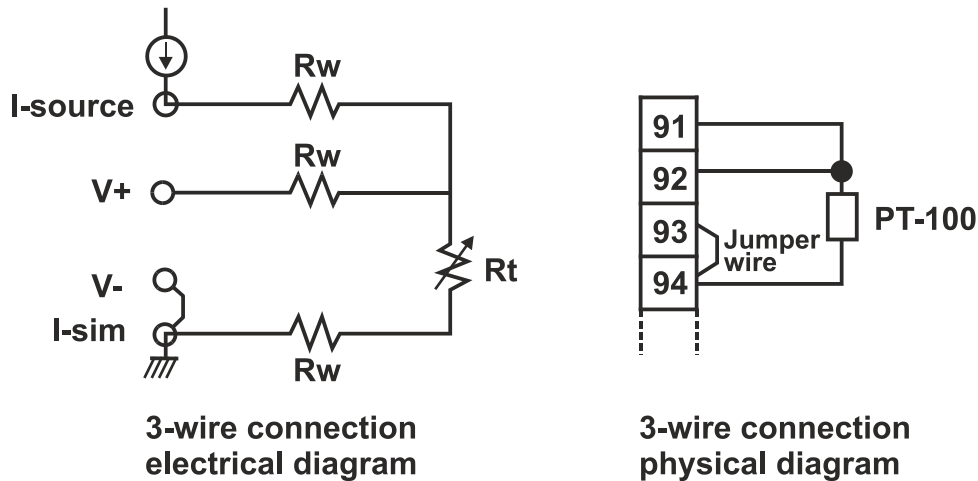

where R_w is the resistance of the wire and R_t is the resistance of the probe. Use two twisted pair shielded cables to connect the PT-100/NI-100 to the card and shortcut the shield to the metal cover of the drive (System Ground).

- PT-100 4-wire connection:

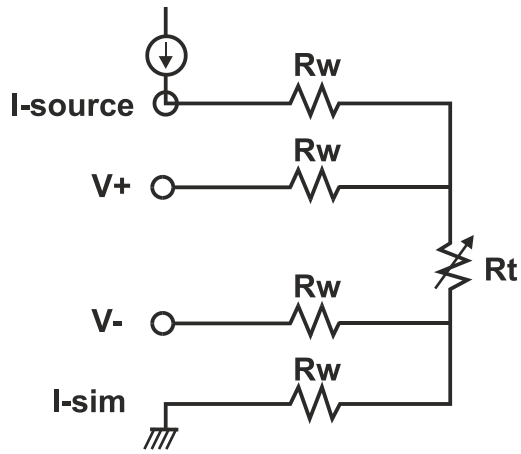

4-wire connection
electrical diagram

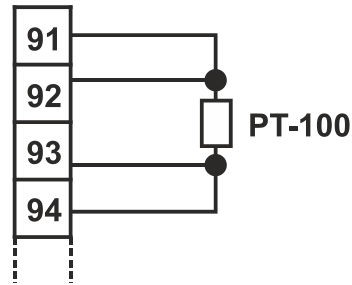

4-wire connection
physical diagram

where R_w is the resistance of the wire and R_t is the resistance of the probe. Use two twisted pair shielded cables to connect the PT-100/NI-100 to the card and shortcut the shield to the metal cover of the drive (System Ground).

- Klixon / PTC / KTY84 connections:

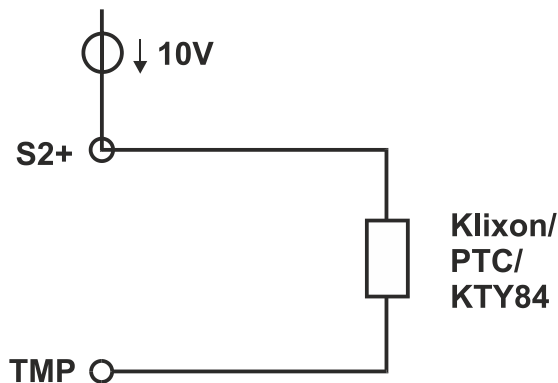

Electrical diagram

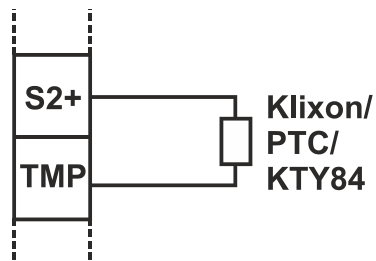

Physical diagram

Use twisted pair shielded cables to connect the probes to the card and shortcut the shield to the metal cover of the drive (System Ground).

⑥ Installation

To install the card refer to the “*Installation of optional cards*” chapter in the “ADV200 WA & ADV200 Quick Start” installation handbook. This chapters describes the procedure for installing the SENSE card.

During installation bear in mind the following:

- Do not connect an external voltage or current generator to the ports as specified in the connections table;
- The analog I/O terminations have no mutual galvanic insulation. Galvanic insulation is only available between the terminations and the control card.
- **CAUTION: Use only the supplied screws !**

Power LED:

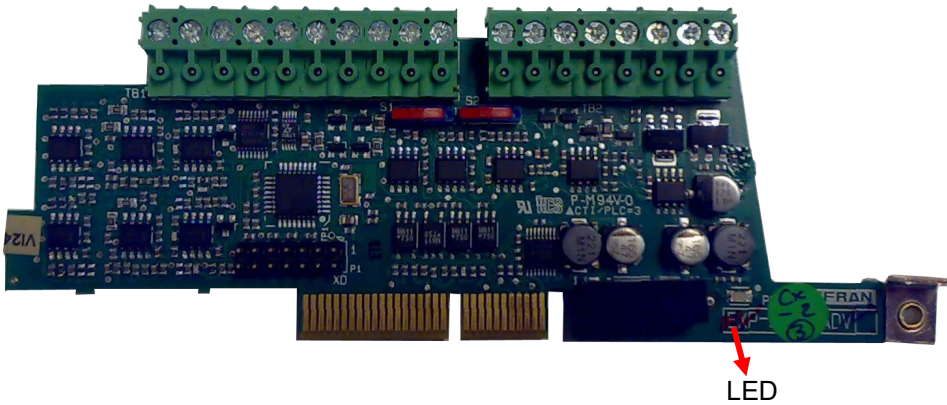

7 Commissioning

Once the card is installed the commissioning phase can start. Use the keypad to go to menu 02, which will show that the card is properly recognized and ready to operate:

T+	T-	EN	LOC	Ilim	n=0	AL
<input type="checkbox"/>	<input type="checkbox"/>	<input type="checkbox"/>	<input type="checkbox"/>	<input type="checkbox"/>	<input checked="" type="checkbox"/>	<input type="checkbox"/>
02.15		PAR: 532				
Slot1 card type						
I/O 6						
Value: 5633						

T+	T-	EN	LOC	Ilim	n=0	AL
<input type="checkbox"/>	<input type="checkbox"/>	<input type="checkbox"/>	<input type="checkbox"/>	<input type="checkbox"/>	<input checked="" type="checkbox"/>	<input type="checkbox"/>
02.16		PAR: 532				
Slot2 card type						
I/O 6						
Value: 5633						



NOTE

I/O 6 identifies the EXP-IO-SENS-100-ADV card. The Slot where the card is plugged in is shown.

8 Ordering Information

When ordering the EXP-IO-SENS-100-ADV card please quote commercial code: **S5L40**.

WEG Automation Europe S.r.l.
Via Carducci, 24 - 21040 Gerenzano [VA] ITALY
Rh. +39 02 967601 - Fax +39 02 9682653 - info.motion@weg.net - www.weg.net