

ATENÇÃO:
-Desconecte da rede elétrica antes de proceder qualquer trabalho neste equipamento.
-Somente profissionais qualificados podem efetuar a instalação e manutenção.
-Obedecer normas nacionais, estaduais, locais e instruções de operação.

WARNING:
-Installation and maintenance to be performed by authorized personnel only.
-User is cautioned to observe all recommendations, warnings and cautions relating to safety of personnel and equipment as well as general and local health and safety laws, codes and procedures.

ATENCIÓN:
- Desconectar de la red eléctrica antes de hacer cualquier trabajo en este equipamiento.
- Recomendase instalación por profesional calificado.
- Respetar normas nacionales y locales.
- Producto destinado a utilización en instalaciones eléctricas de baja tensión.

WARNING:
- Bevor irgend eine Arbeit am Gerät vorgenommen wird, muss sichergestellt sein, dass die Einheit stromlos und freigeschaltet ist.
- Sämtliche Arbeiten an der Einheit dürfen daher ausschließlich nur von Fachpersonal vorgenommen werden.
- Die jeweils geltenden nationalen, örtlichen und anlagenspezifischen Bestimmungen und Erfordernisse sind zu berücksichtigen.

CT DWB160 3ph

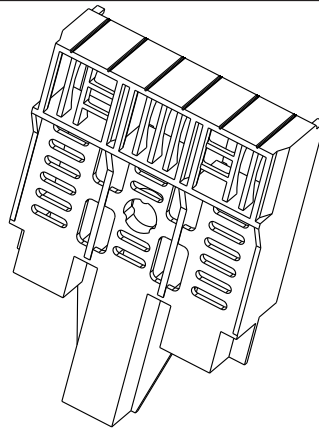
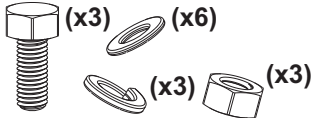
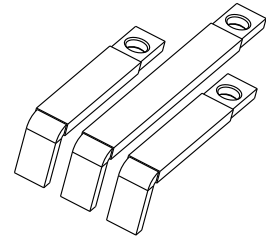

CB DWB160

CT DWB160 4ph

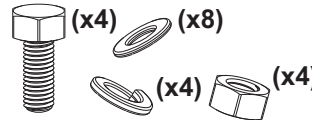
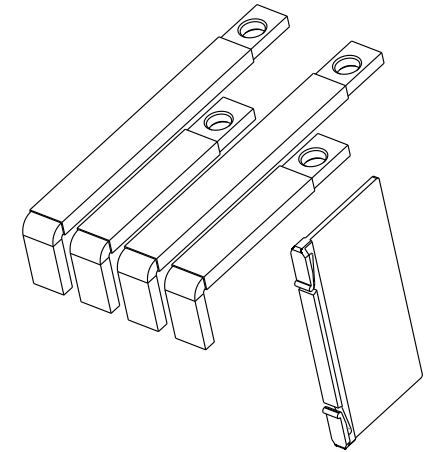

DANGER
RISK OF ELECTRIC SHOCK,
BURN OR EXPLOSION

- 1) TURN OFF AND LOCK OUT ALL POWER SUPPLYING THIS EQUIPMENT BEFORE WORKING ON OR INSIDE EQUIPMENT.
 - 2) REPLACE ALL DEVICES, DOORS, AND COVERS BEFORE TURNING ON POWER TO THIS EQUIPMENT.
 - 3) ALWAYS VERIFY THAT NO VOLTAGE IS PRESENT BEFORE WORKING ON OR INSIDE EQUIPMENT, AND ALWAYS FOLLOW GENERALLY ACCEPTED SAFETY PROCEDURES.
- FAILURE TO FOLLOW THESE INSTRUCTIONS WILL RESULT IN DEATH OR SEVERE INJURY.**

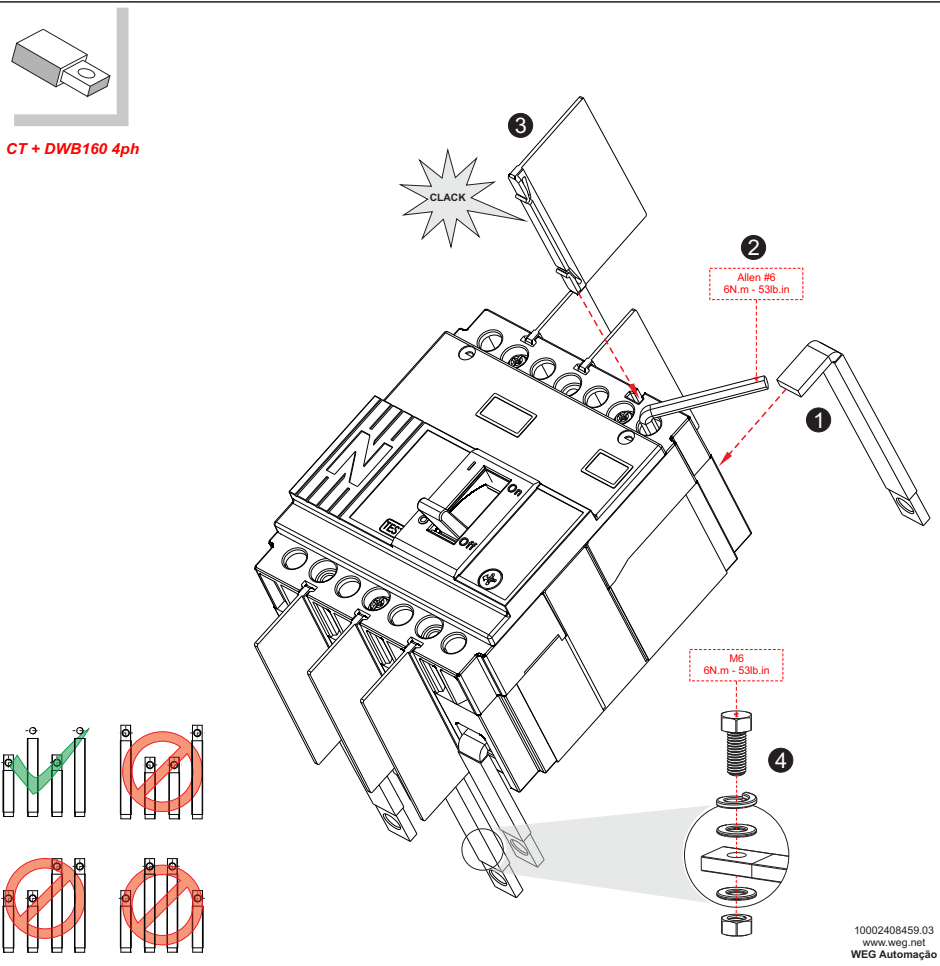
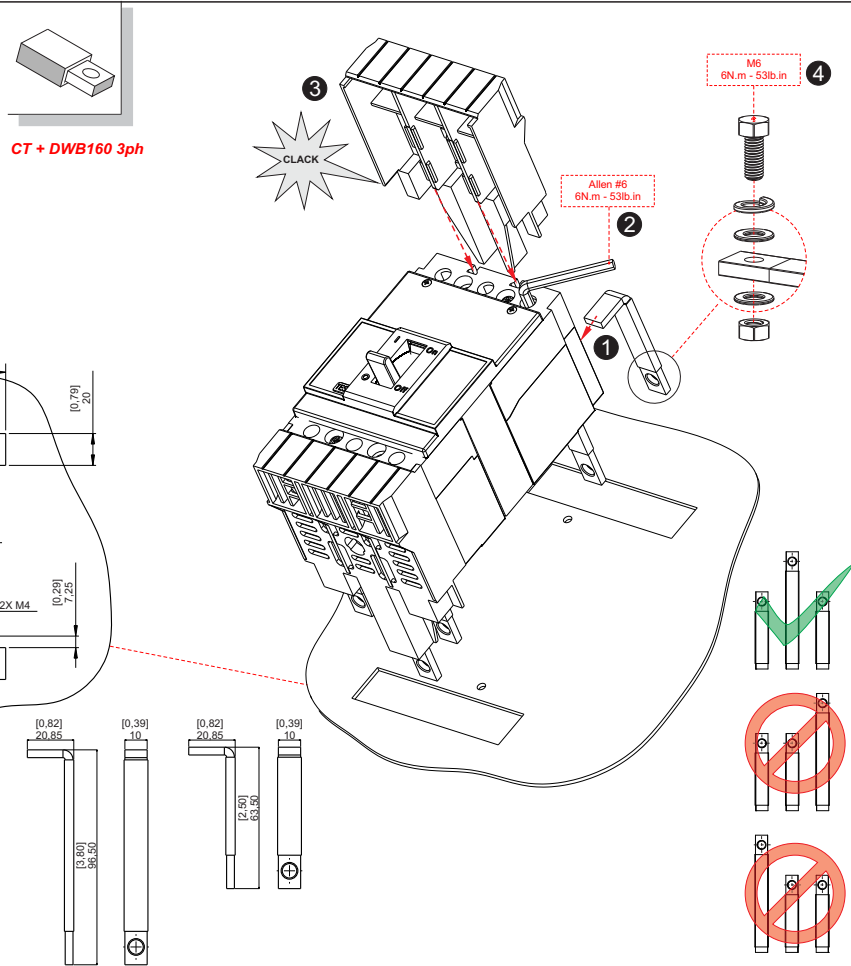

CT DWB250 3ph

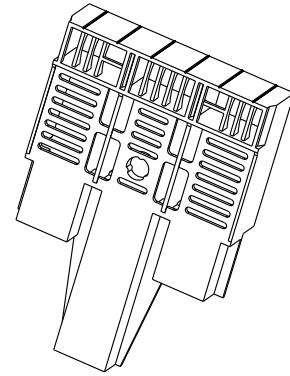
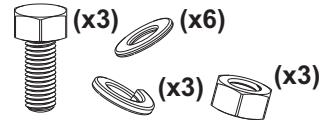
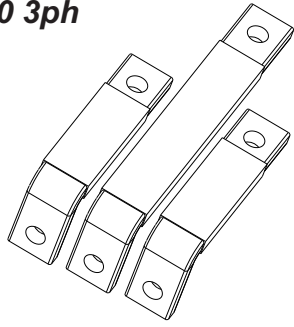

CB DWB250

CT DWB250 4ph

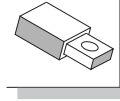
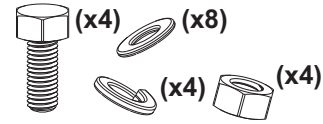
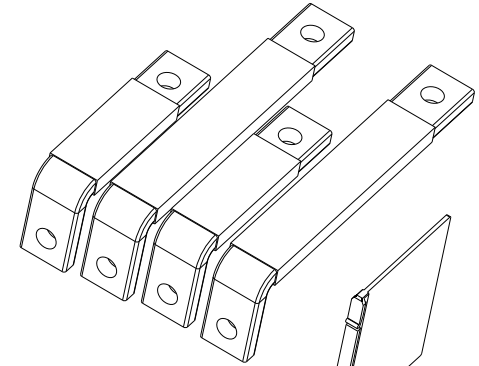

CT + DWB250 3ph

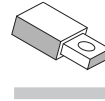
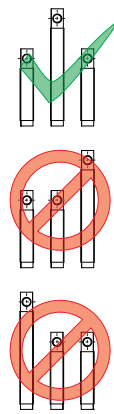
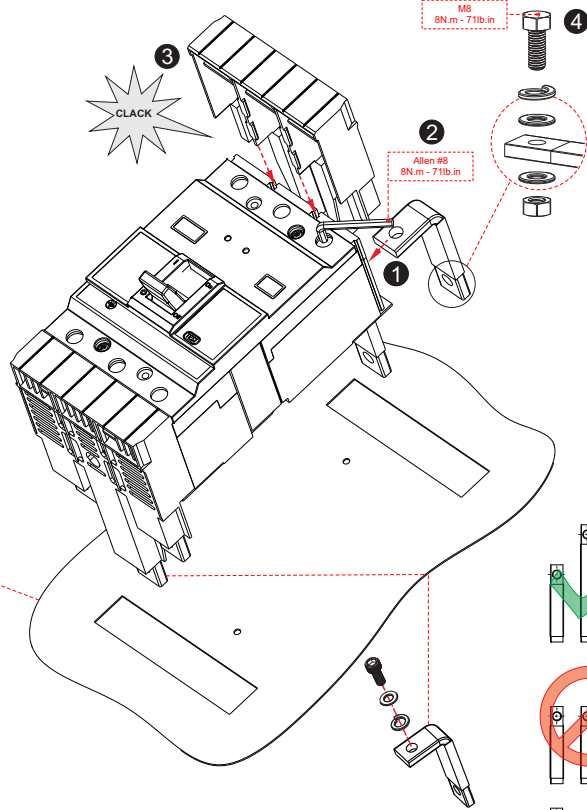
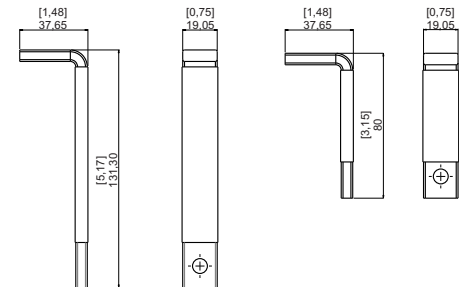
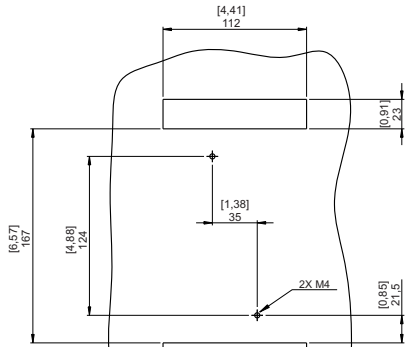

CT + DWB250 4ph

