

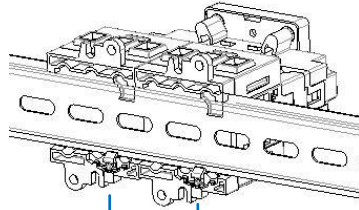

MANUAL DE INSTALAÇÃO
INSTRUCTION MANUAL
MANUAL DE INSTALACIÓN
SERIE MSWR25/40

SWITCH-DISCONNECTOR SIX POLES /CHANGE-OVER

DIRECT COMMAND

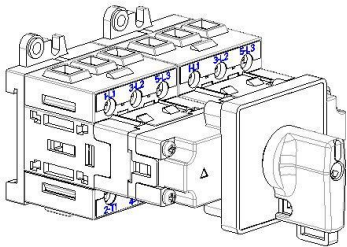

MOVE DOWN CURSOR
BY SCREWDRIVER

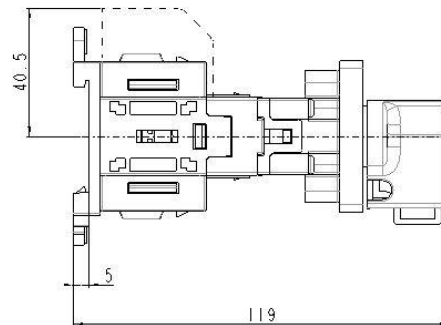
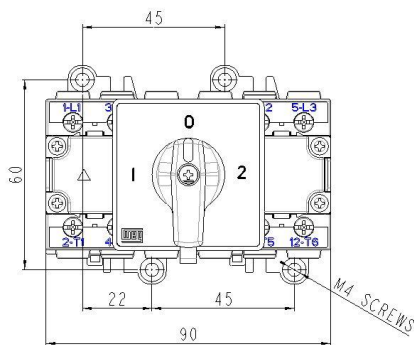
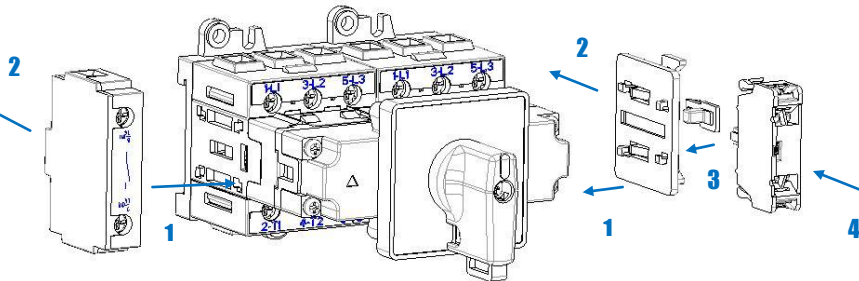
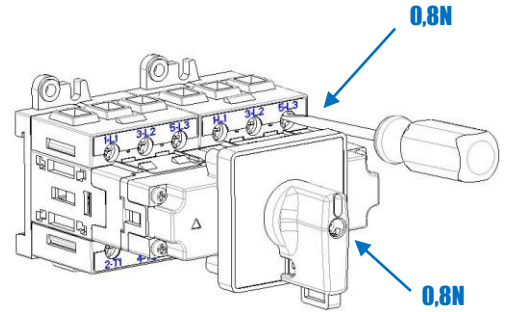

ATENÇÃO: Para prevenir choques elétricos, desconecte a fonte de alimentação antes da instalação ou manutenção.

ATTENTION: To prevent electrical shock disconnect from power source before installing or servicing



ATENCIÓN: Para prevención de choque eléctrico desconecte de la fuente de alimentación antes de una instalación o mantenimiento