

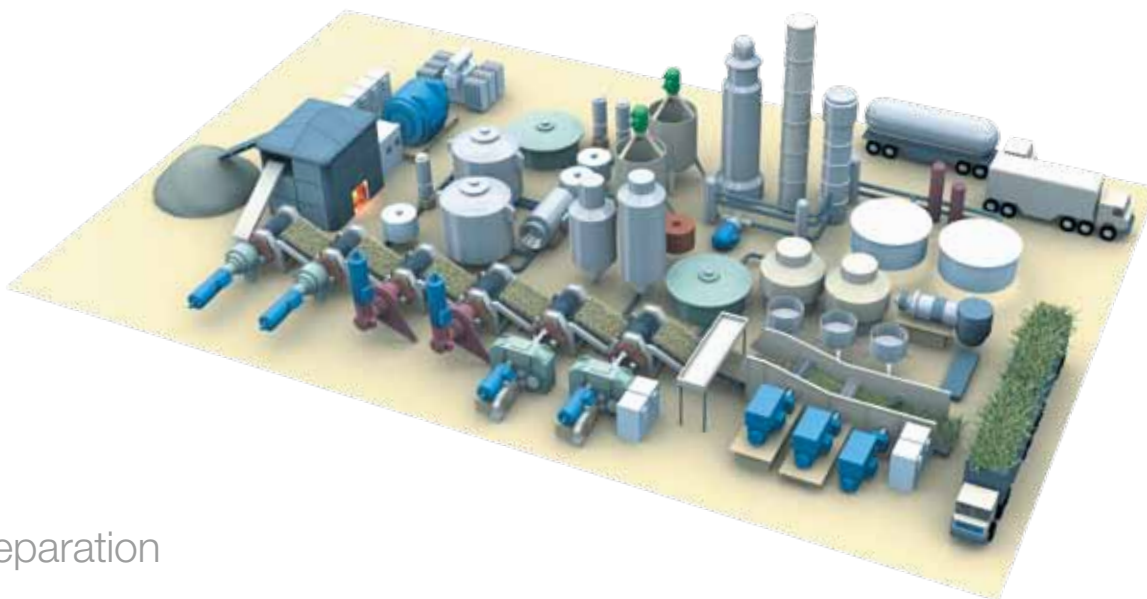

Solutions for Sugar & Ethanol Industry



Designed with modern technology and high performance, WEG products offer low maintenance, high reliability and major flexibility for the sugar and alcohol industry, resulting in efficient industrial solutions.



Preparation

M Line Motor (Squirrel-Cage and Slip-Ring Motors)

The “M” line motors were designed with high technology and are suitable to drive chippers, levelers or shredders and, regardless of their configuration (squirrel cage or slip ring), ensure high performance and reliable operation.

In power ratings up to 50,000 kW, frame size 280 to 1,800 (IEC) and voltage up to 13,800 V, WEG “M” line motors can be supplied in two basic configurations: squirrel cage motor or slip ring motor.

■ Squirrel cage rotor

Due to the design versatility and excellent operation conditions, the squirrel cage motor ensures high performance, requires low maintenance, low investment and thus is considered the best solution for sugar cane preparation processes.

The main starting methods are:

- Direct-on-line starting (DOL)
- Start by frequency inverter
- Pony-Motor starting
- Start with soft starter or autotransformer

The choice between a squirrel cage motor and slip ring motor should be based on the characteristics and the moment of inertia of the machines applied in the cane preparation process, on the demanded output power and the operating curve.

■ Wound rotor motor (slip ring motor):

The selection of slip ring motors is the best solution for starting high inertia loads and resisting torques, the main features of chippers, shredders and leveler drives.

The main characteristic of the slip ring motors is the insertion of resistance in the rotor (secondary) circuit thus providing higher start torque at low starting current.

These motors can be supplied with fixed brush holders or with a motorized brush lifting system for applications where the insertion of a resistance in the rotor (secondary) circuit during operation is required. In this application, the resistance in the rotor (secondary) circuit is inserted to the rotor winding through the brushes and slip rings only during motor start-up. After rated operating conditions are reached, the rotor is short-circuited, the brushes are lifted automatically and the motor operates as a squirrel cage motor thus preventing unnecessary brush and slip ring wear



Advantages of slip ring induction motor with a brush lifting system:

- There is no unnecessary carbon brush and slip ring wear.
- Reduced machine stop times for slip ring interventions and replacement of carbon brushes.
- Very little accumulation of carbon brush powder inside the motor maintaining high insulation levels of the rotor winding.
- Increase of carbon brush and slip ring lifetime and, consequently increase of the motor lifetime.

Medium Voltage Switchgears and Controlgears – MCCs

The MCCs are assembled and tested for voltages ranging from 2.3 kV to 36 kV. The MCCs meet the requirements specified in standard NBR IEC 62271-200 ensuring easy assembly and maintenance works with high flexibility to match the different characteristics of the sugar and alcohol sector.

Advantages

- Available in a variety of options and forms of internal separation to meet customer needs and requirements
- Quick replacement of circuit breakers and contactors due to the interchangeability of the cart
- Low maintenance
- Modular construction allows for easy and fast expansion
- Quick factory assembly
- Simple and safe operations
- Easy access to the compartments through doors and removable covers for maintenance works
- Cart for circuit breaker/contactator transport (optional)
- Interlocking system against incorrect operations

Applications

The MCCs are used for a wide range of applications in MV systems, including:

- Utility substations
- Main protection and sectioning of factories and industrial installations
- Pumping stations
- Train systems
- Thermal and hydroelectric power generation plants
- Medium voltage motor start
- Unit substations
- Load distribution boards
- Interlinking panels
- Fixed and variable capacitor banks

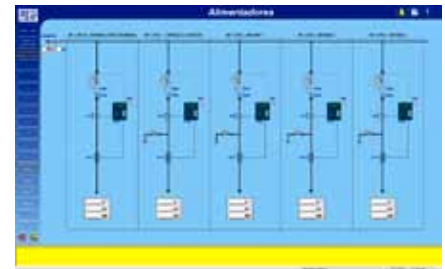

Medium Voltage Switchgear - Model MTW

The MTW switchgear is resistant to internal arch ensuring safe operations. It is also fitted with several interlock devices between the door of the circuit breaker compartment and the circuit breaker extraction cart.

The used circuit breaker is **maintenance-free** and can be placed in the extracted position without requiring the opening of the switchgear door.

WEG switchgears, designed for application in power generation systems, meet IEC 62271-200 requirements. The whole structure receives a special surface treatment to withstand the aggressive environments present in the sugar and alcohol plants.

Advantages

- Loss of Service continuity category: LSC2B-PM
- Resistant to internal arch
- High degree of protection for the user
- Reduced dimensions, allowing smaller electrical room for installation
- Circuit breaker can be moved from the testing position to the insertion position and vice versa with the door of the switching compartment closed
- Option for ground sectioning
- Structure, components and dimensions standardization
- Mechanical switch control with closed door
- Cables can be accessed from the front side



Sugar Cane Mill

WEG offers, as solution for the sugar cane milling process, its “H” line motors which, in spite of their compactness and reduced weight, ensure high reliability, require low maintenance and are very tough in operation. In general, these motors are driven by modern frequency inverters that allow torque control over the whole motor speed range enabling network communication, display of readiness, prompt parameter change and granting high operation versatility. Whether with a single drive for all cylinders or with individual drives for each cylinder, the “H” line motors, due to their compactness, allow several arrangements for the twin mill drives.

H Line Motors (squirrel Cage)

- Power rating from 100 to 3.150 kW
- Voltages 220 from 11,000 V
- Speed range from 3,600 rpm to 600 rpm
- Both directions of rotation
- Speed change of each cylinder separately (when fitted with individual drives for each cylinder)
- Total protection against overload with immediate motor stop
- Simple automation of the milling process
- Easy measurement of the output, torque and speed
- Low maintenance
- Reduced size, weight and cost
- Improvement in plant efficiency
- Increase of extraction capacity
- Reuse of the steam for energy generation
- Better cost-benefit ratio to increase mill capacity
- Civil installations are lighter and simpler
- High speed gearbox is not required

Sugarcane Mill Control Block Diagrams

WEG can provide the best solution by replacing steam turbines with electric adjustable speed drive systems and supplying complete automation for the milling process with flexible control algorithm, with speed and torque monitoring system, control of the soaking time, power supply, temperature and lubrication system.

Milling cylinder synchronization

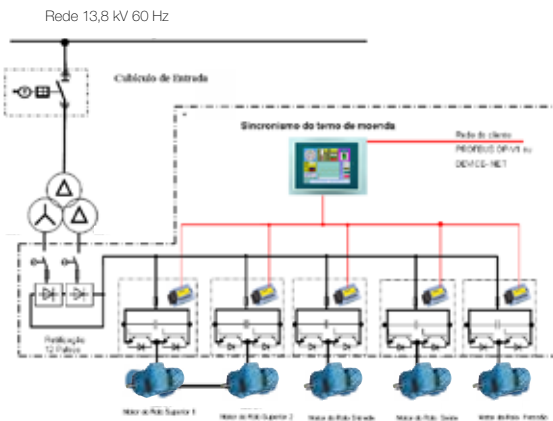

Mill monitoring and control system

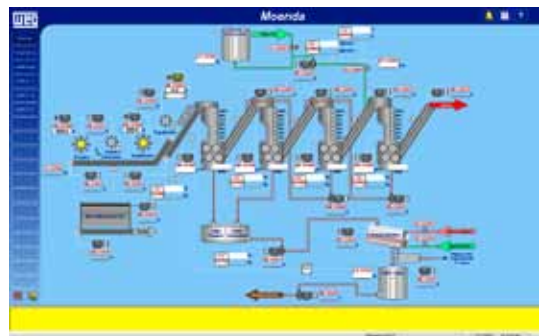

Dry transformers

Safety and excellent cost/benefit ratio.

Advantages:

- There is no explosion risk and flame propagation if extinguished as soon as the heat source is eliminated since the impregnation resin has self-extinguishing properties.
- There is no environmental contamination and no toxic gas release.
- No complex civil engineering works are required (firewall, oil sump). Transformer can be installed near the load center.
- Reduced dimensions (in the area required for the installation of an oil-filled transformer you can install a dry transformer with double output).

Characteristics:

- Power rating: 300 to 15,000 kVA
- Voltage Classes: 7.2 - 15 - 24.2 and 36.2 kV
- Insulation Class: F (155°C)
- Degree of Protection: IP 00 to IP 55
- Standards: ABNT - NBR10295/IEC60076-11

MVW-01 Medium Voltage Frequency Drive

The MVW-01 variable frequency drive has been designed with state-of-art technology through a multilevel structure with high voltage IGBTs (6.5 kV) reducing the harmonic currents in the motor to extremely low levels.

Trying to demystify the application of medium voltage frequency drives, the MVW01 line follows the same programming philosophy of WEG low voltage inverters.

The medium voltage frequency drives, Model MVW-01, are fitted with technological innovations by joining sturdiness, simplicity, reliability and safety into a compact solution with last generation technology.

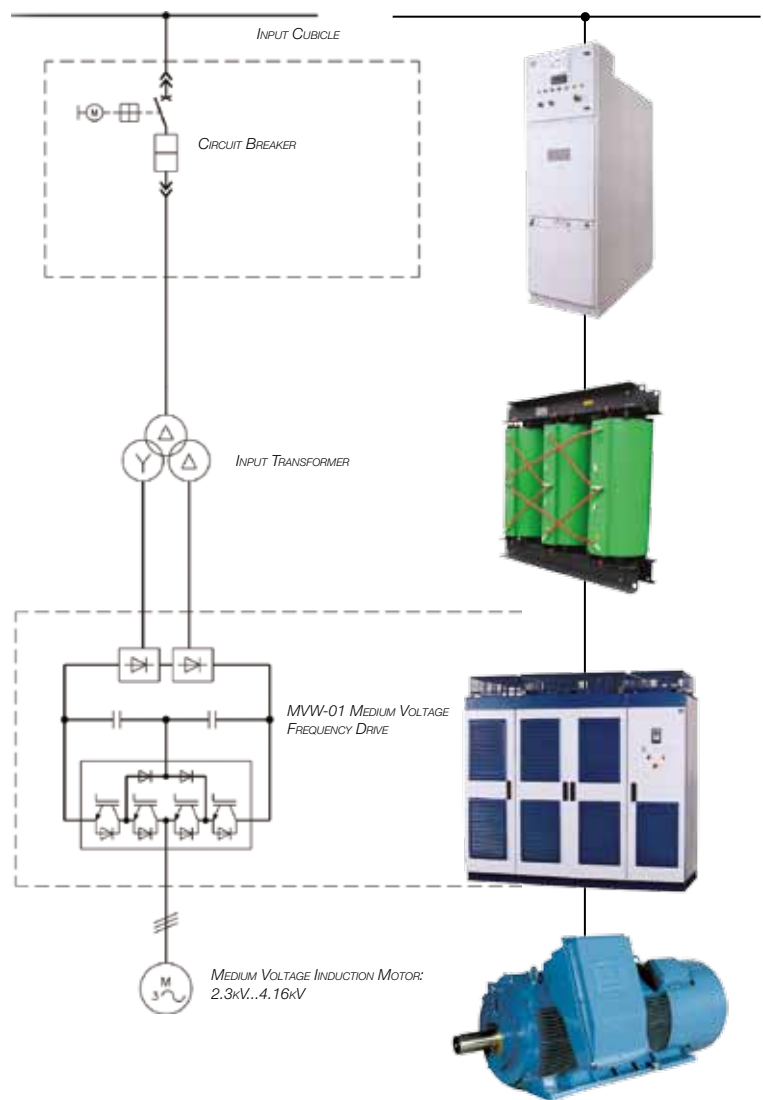

CFW11 - Modular Drive

The CFW-11M (modular drive) is the new generation of WEG VSDs for high powers. It is available for power ratings from 400 to 2500 HP and voltages from 380 to 690 V, with 6 and 12 pulse input or regenerative rectifier.

The modular construction allows the AFW-11M (modular drive) to be configured according to the required customer power ratings.

The used concept of book format modules (width much smaller than depth) allows high size reduction and drive compactness.

Configuration example with 5 UP11 and 6 pulse rectifier

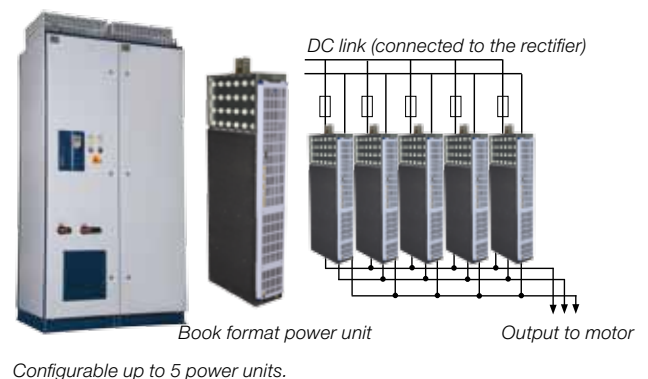
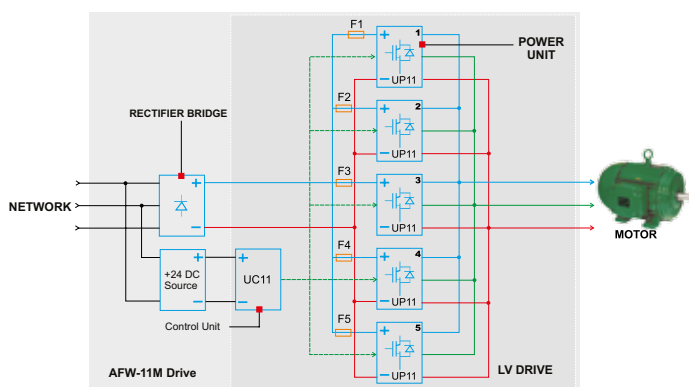

Note: The fuses shown in the block diagram above are not included in the VSD CFW-11M, but are part of the AFW-11M drive.

Energy Generation

WEG offers a complete solution for energy generation. The developed products ensure high quality and technology standards and meet world market requirements. WEG also offers a well-trained technical team with engineers to provide technical support to its customers and ensure the most efficient solution for energy generation.

Generators

WEG "S" Line Turbogenerators (4 poles) are manufactured for power ratings up to 50,000 kW (62,500 kVA) and frame sizes ranging from 400 to 1,250 (IEC). They can be operated up to 13,800 V and are manufactured within a high technological verticalization process which ensures the absolute quality of the components.

The "S" Line Turbogenerators are engineered products and are designed according to the requirements of each customer.



Switchgear and Controlgear

The controlgears and switchgears consist of MTW and PNW steel plates ensuring degree of protection IP-4x.

The switchgear is intended for generator control and protection meeting IEC 62271-200 / IEC 694 requirements and is certified for tests up to 50 kA.

The main equipment includes:

- Generator Output Panels
- Generator Surge and Excitation Panels
- Generator Neutral and Grounding Connection Panel
- Generator Control, Protection and Excitation Panel
- Energy Import/Export Panel
- Auxiliary Operation Panel
- Interconnection Panel with Utility
- Distribution Panel
- 24Vdc or 125Vdc Battery Set and Battery Charger



Transformers

WEG transformers can be applied to all steps of the production process of the sugar and alcohol mill, from the voltage step-down and step-up substation (for energy export) up to the supply of the secondary substations that supply all areas of the plant, such as the chipper, sugar plant, distillery, water treatment station (ETA) and the sugarcane twin mill (in the 12 pulse inverters), etc.



Turbogenerator Monitoring and Control

The WEG Monitoring and Control System for turbogenerators ensures total integration between the operator and the generation center and provides accurate visual information on the temperature, pressure, vibration, lubrication and protection status of the turbogenerator.

The maintenance is facilitated by the information displayed on the online historical variable record, trend charts and turbogenerator operation data.

The energy production and consumption reports can be easily accessed via data bank enabling the integration with the management systems.

The easiness and flexibility of the energy import and export control makes the plant operation more operator-friendly.

Turbogenerator Monitoring and Control System

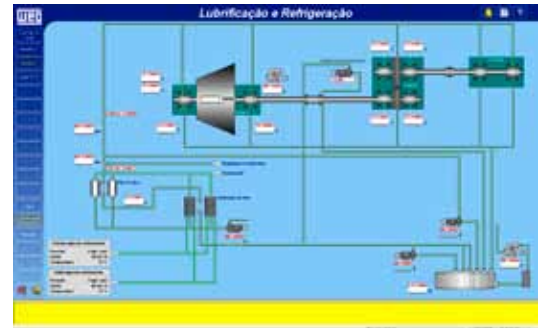

Substation

Conventional and movable substations in turn-key system, classes up to 550 kW. WEG offers high voltage substations in turn-key systems.

In terms of supply, besides the traditional WEG supply package (transformers, MV/HV panels, digital systems, electric and electronic components, etc.), all the other equipment and services (from design to start-up) required to deliver ready-to-use substations to the customer are included.



Substation Monitoring and Control System

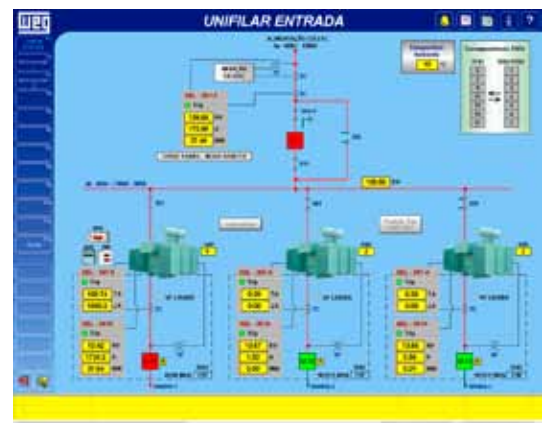

Process

W22 Plus and W22 Premium

The WEG new W22 motor line ensures more efficiency and reliability to the industry.

- Longer maintenance intervals
- Low noise level
- Low vibration level
- Easy, quick and flexible installation
- Interchangeability
- Longer lubrication intervals
- Lower operating temperature
- Longer lifetimes



Wwash Motors

The WEG Wwash motor line has been specially developed for environments where careful hygiene and washing procedures are required.

The Wwash motor is painted with the exclusive WEG NOBAC® coating which has anti-microbial properties supplying reliable and up-dated solutions for the cases where hygiene and reliability are crucial.



Ex Motors to be driven by Frequency drives

Explosion-Proof (Ex-d) and Non-Sparking (Ex-n):

- These motors can be operated in a frequency range from 6 to 70 Hz (II-pole motors, meeting several applications in the sugar and alcohol industry).
- Ex-d motors are designed to operate in the Classified Area - Zone 1 (ABNT/IEC), Group IIA / IIB. They are suitable to be operated in Temperature Class T4 and thus can be installed in environments with ambient temperature up to 60°C.
- Ex-n Motors are designed to operate in the Classified Area - Zone 2, Group IIA / IIB / IIC - T3 (ABNT/IEC). They are suitable to be operated in Temperature Class T3 and thus can be installed in environments with ambient temperature up to 40°C.



Process Automation

WEG offers a complete solution for the whole sugar and alcohol production process starting with instrument design up to the monitoring and controlling system. WEG's specialist team in the sugar and alcohol industry can provide a high integration between the different automation and process control levels. The automation focused on the requirements of each customer allows the creation of an integrated and customized system that makes plant operation and maintenance easier.

Main Characteristics of the System Integration:

- Automation & Network Architecture
- Control variable detailing
- P&I flowchart (Process & Instrumentation)
- P&ID Flowchart (Process & Instrument diagram)
- Interconnection diagrams
- Descriptions of the control loop and interlocks
- Instrument data sheets
- Field design, managing and material list
- Typical instrument details
- Process calculating log
- Calculating log for the communication network
- Development of Application Software for PLC, Supervisory Program and HMIs
- Integration of intelligent MCCs

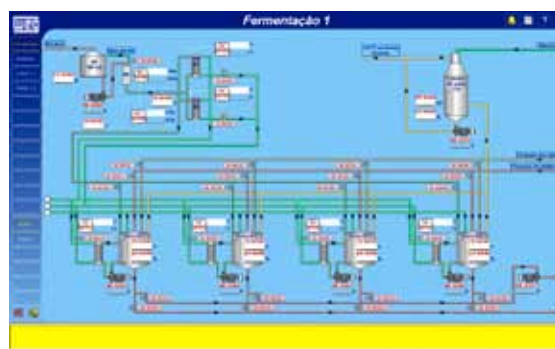
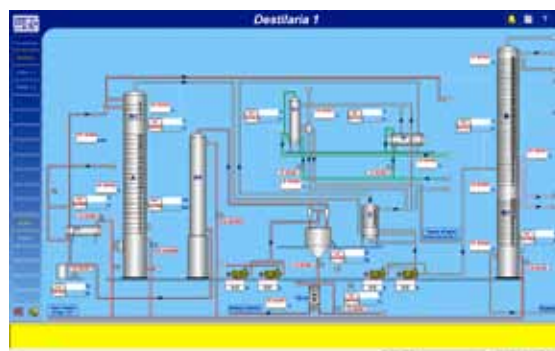

Remote Operation and Maintenance

Internet connection allows a safe and prompt remote intervention for immediate maintenance and operation works in the plant with reduced cost.



Supervisory and control stations with tele-command via internet

WEG CFW-11 Variable Frequency Drive

The CFW-11 frequency inverter is a variable speed drive designed with state-of-art technology for driving three-phase motors. This drive can be used in a wide range of applications in the sugar and alcohol industry since it is designed for running on either Normal or Heavy Duty Cycle loads. Its performance is excellent, providing increased productivity and an improvement in the quality of the process in which it is used.

Advantages:

- Modular and compact
- 12-pulse rectifier for harmonics reduction
- Regenerative rectifier for centrifugal machines
- High robustness and durability



1.5 to 40 HP
200-240 V – single-phase
(up to 3 HP) or three-phase
2 to 60 HP 380-480 V – three-phase

SSW-06 - Soft-Starter

The SSW-06 Series Soft-Starters are static starters designed for the acceleration, deceleration and protection of three phase induction motors. The voltage control applied to the motor, by means of thyristor firing angle variation allows smooth starting and stopping. Proper variable adjustment enables to optimize the motor starting torque so that the starting current is as low as possible. WEG SSW-06 Series Soft-Starters, microprocessor based and totally digital, are produced with state-of-the art technology and are designed to ensure the highest performance in the starting and stopping procedures of induction motors providing a complete process drive solution at low-cost. The Human-Machine Interface (HMI) allows easy parameter setting thus enabling an easy motor start-up and operation. The incorporated "Pump Control" feature allows efficient pump control avoiding water hammer in the pipeline. The torque control function allows motor acceleration and deceleration by linear speed ramp.



WEG CFW-08 and CFW09 Variable Frequency Drives

The CFW-08 and CFW-09 are variable speed drive series with the state-of-the-art technology for three phase induction motors. The used Vectrue® Technology allows the new generation of WEG Variable Frequency Drives combining the V/F, Sensorless Vector and Closed Loop Vector (with encoder) control techniques in one product. All these control techniques can be programmed via parameters. Innovations also have been introduced for applications that require an optimal braking torque, named as “Optimal Braking®”. This new feature eliminates, in some applications, the need for dynamic braking resistor resulting in a simpler, more compact and economic solution for motor drives.



Vectrue Technology®

- Programmable V/f scalar and vector controls available in the same product
- Sensorless vector control and optionally with encoder control
- Sensorless vector control allows high torque and quick response even at low speeds and at startup
- The self-tuning function automatically sets the vector control to the motor and to the load

Applications:

- Centrifugal pumps
- Process dosing pumps
- Fans / Blowers
- Stirrers & Mixers
- Extruding machines
- Conveyors
- Roller Tables
- Granulators / Peletizers
- Dryers and Rotating ovens
- Rotating filter
- Coilers / decoilers
- Cutting and Welding Machines



Low Voltage Motor Control Center

Highly standardized, these products were designed to provide easy assembly, installation, maintenance, future updates and interchangeability between control units of the same size and function.

They are certified (available) as fully type-tested assemblies (TTA) or partially type-tested assemblies (PTTA) to IEC 60439 and as Type 1 and Type 2 Coordination in accordance with IEC 60947. WEG MCCs ensure reliable operation and maintenance, mainly what applies to Brazilian Regulatory Rule for Electrical Installations and Services (NR-10).

The MCCs are available in two versions:

- **Conventional MCC** - arranged by column compartments with fixed or withdrawable units;
- **Intelligent MCC** - It has the same features as the conventional MCC version. However each drawer can incorporate a soft-starter, a variable frequency drive, a microprocessor based relay thus adding protection, monitoring, control and communication functions in a Fieldbus network with access to digital control and monitoring systems.



WEG coatings offer complete solutions for machine and equipment protection ensuring higher corrosion resistance and reducing maintenance interventions.

WEGTHANE ANTIFUNGO 508

WEGTHANE ANTIFUNGO 508 is an aliphatic & acrylic high solid PU finish coating. **It has excellent antifungal properties for external coating of alcohol storage tanks** ensuring better gloss and color retention during longer periods when compared with the conventional aliphatic PU coatings. In addition to that, the aliphatic acrylic PU finish coating also ensures excellent corrosion, waterproofing and weathering protection. This aliphatic acrylic PU finish coating with high solid content applied over the primer WEGPOXI ERD 322 ensures **a quick paint dry and is ideal for system protection.**



WEG FENOXI

WEG Fenoxi paint is recommended for coating of sugar manufacturing equipment and storage tanks (including alcohol) since it ensures excellent corrosion protection in aggressive environments and is certified for contact with alcoholic foods.



LACKPOXI AE DF

LACKPOXI AE DF is an anticorrosion epoxy primer of high thickness. This coating is not toxic and has been **certified by the Institutes Adolf Lutz and Ital** making this paint ideal for internal coating of drinking water tanks, piping, machines and equipment for the food industry.

SYNTHETIC ENAMEL

WEG Tintas also has a complete line of fast drying, high gloss synthetic enamel coatings recommended for protection and aesthetic equipment finishing.

WEGTERM CVA 660 600°C

This coating is resistant to temperatures up to 600 °C and can be applied directly onto carbon steel substrates such as outside surface of chimneys, furnaces, boilers, heat exchangers, piping and equipment operating at high temperatures.

ZINC ETHYL SILICATE N2231 ALUMINUM

This coating offers cathodic protection (Zn) and barrier protection (Al) and ensures fast drying times of internal coatings of gas spray towers and chimneys with excellent resistance to moisture and temperatures up to 500 °C.

Services

As market leader in the supply of motors and generators for the sugar and alcohol sector, WEG also offers all factory services as well as field services including inspections, repairs and retrofitting of medium and large size machines including other brands.



- DC motors and DC generators up to 10,000 kW
- Three-phase induction motors (squirrel cage or slip ring) up to 50,000 kW (low, middle and high voltage)
- Synchronous motors (with brushes or brushless) up to 50,000 kW (low, medium and high voltage)
- Turbogenerators up to 62,500 kVA
- Hydrogenerators up to 200,000 kVA
- Power transformers in voltage classes up to 550 kV



WEG Worldwide Operations

ARGENTINA

WEG EQUIPAMIENTOS
ELECTRICOS
San Francisco - Cordoba
Phone: +54 3564 421 484
info-ar@weg.net
www.weg.net/ar

WEG PINTURAS - Pulverlux
Buenos Aires
Phone: +54 11 4299 8000
tintas@weg.net

AUSTRALIA

WEG AUSTRALIA
Victoria
Phone: +61 3 9765 4600
info-au@weg.net
www.weg.net/au

AUSTRIA

WATT DRIVE - WEG Group
Markt Piesting - Vienna
Phone: +43 2633 404 0
watt@wattdrive.com
www.wattdrive.com

BELGIUM

WEG BENELUX
Nivelles - Belgium
Phone: +32 67 88 84 20
info-be@weg.net
www.weg.net/be

BRAZIL

WEG EQUIPAMENTOS ELÉTRICOS
Jaraguá do Sul - Santa Catarina
Phone: +55 47 3276-4002
info-br@weg.net
www.weg.net/br

CHILE

WEG CHILE
Santiago
Phone: +56 2 784 8900
info-cl@weg.net
www.weg.net/cl

CHINA

WEG NANTONG
Nantong - Jiangsu
Phone: +86 0513 8598 9333
info-cn@weg.net
www.weg.net/cn

COLOMBIA

WEG COLOMBIA
Bogotá
Phone: +57 1 416 0166
info-co@weg.net
www.weg.net/co

FRANCE

WEG FRANCE
Saint Quentin Fallavier - Lyon
Phone: +33 4 74 99 11 35
info-fr@weg.net
www.weg.net/fr

GERMANY

WEG GERMANY
Kerpen - North Rhine Westphalia
Phone: +49 2237 9291 0
info-de@weg.net
www.weg.net/de

GHANA

ZEST ELECTRIC GHANA
WEG Group
Accra
Phone: +233 30 27 664 90
info@zestghana.com.gh
www.zestghana.com.gh

INDIA

WEG ELECTRIC INDIA
Bangalore - Karnataka
Phone: +91 80 4128 2007
info-in@weg.net
www.weg.net/in

WEG INDUSTRIES INDIA

Hosur - Tamil Nadu
Phone: +91 4344 301 501
info-in@weg.net
www.weg.net/in

ITALY

WEG ITALIA
Cinisello Balsamo - Milano
Phone: +39 02 6129 3535
info-it@weg.net
www.weg.net/it

JAPAN

WEG ELECTRIC MOTORS
JAPAN
Yokohama City - Kanagawa
Phone: +81 45 550 3030
info-jp@weg.net
www.weg.net/jp

MALAYSIA

WATT EURO-DRIVE - WEG Group
Shah Alam, Selangor
Phone: 603 78591626
info@wattdrive.com.my
www.wattdrive.com

MEXICO

WEG MEXICO
Huehuetoca
Phone: +52 55 5321 4231
info-mx@weg.net
www.weg.net/mx

VOLTRAN - WEG Group

Tizayuca - Hidalgo
Phone: +52 77 5350 9354
www.voltran.com.mx

NETHERLANDS

WEG NETHERLANDS
Oldenzaal - Overijssel
Phone: +31 541 571 080
info-nl@weg.net
www.weg.net/nl

PERU

WEG PERU
Lima
Phone: +51 1 472 3204
info-pe@weg.net
www.weg.net/pe

PORTUGAL

WEG EURO
Maia - Porto
Phone: +351 22 9477705
info-pt@weg.net
www.weg.net/pt

RUSSIA and CIS

WEG ELECTRIC CIS
Saint Petersburg
Phone: +7 812 363 2172
info-ru@weg.net
www.weg.net/ru

SOUTH AFRICA

ZEST ELECTRIC MOTORS
WEG Group
Johannesburg
Phone: +27 11 723 6000
info@zest.co.za
www.zest.co.za

SPAIN

WEG IBERIA
Madrid
Phone: +34 91 655 30 08
info-es@weg.net
www.weg.net/es

SINGAPORE

WEG SINGAPORE
Singapore
Phone: +65 68589081
info-sg@weg.net
www.weg.net/sg

SCANDINAVIA

WEG SCANDINAVIA
Kungsbacka - Sweden
Phone: +46 300 73 400
info-se@weg.net
www.weg.net/se

UK

WEG ELECTRIC MOTORS U.K.
Redditch - Worcestershire
Phone: +44 1527 513 800
info-uk@weg.net
www.weg.net/uk

UNITED ARAB EMIRATES

WEG MIDDLE EAST
Dubai
Phone: +971 4 813 0800
info-ae@weg.net
www.weg.net/ae

USA

WEG ELECTRIC
Duluth - Georgia
Phone: +1 678 249 2000
info-us@weg.net
www.weg.net/us

ELECTRIC MACHINERY

WEG Group
Minneapolis - Minnesota
Phone: +1 612 378 8000
www.electricmachinery.com

VENEZUELA

WEG INDUSTRIAS VENEZUELA
Valencia - Carabobo
Phone: +58 241 821 0582
info-ve@weg.net
www.weg.net/ve

For those countries where there is not a WEG own operation, find our local distributor at www.weg.net.



WEG Group
Jaraguá do Sul - SC - Brazil
Phone: +55 47 3276 4000
info-br@weg.net
www.weg.net

