



Storage of medium-sized rotating electrical machines

Jorge Luis Morales Gularte
WEG
Brazil
gularte@weg.net

Summary – The rotating electrical machines used in different applications are supplied in ideal operating conditions and are supposed to operate as soon as possible.

Depending on the application, however, the machine may remain stored for weeks, months and even years until it is installed and begins operation. That might cause changes in their electrical and mechanical properties.

Many factors influence the properties of the machine during the storage period, such as ambient temperature, moisture, contamination, corrosive agents, salt spray, vibration, etc.

The maintenance areas of the companies are increasingly adopting preventive measures so as to prevent operating problems at the start-up or replacement of electric motors or generators.

The main effects caused by long periods of storage are the corrosion of machined parts, damage to bearings and reduction of the insulation resistance of the windings.

It is very important that the users be aware that the preventive maintenance during storage is as important as the maintenance during the operation of their machines. Several procedures and measures must be part of the maintenance plan for storage of machines.

In this article we discuss the problems that may occur with medium-sized rotating electrical machines subject to long periods of storage and cares that must be taken so that these problems do not occur or are minimized.

It is understood by medium-sized electrical machines with a frame size IEC 280 to 1250 and frame sizes NEMA 44 to 200.

INDEX OF TERMS: ELECTRICAL MACHINE, STORAGE, MAINTENANCE;

1 INTRODUCTION

There are several situations in which users of rotating electrical machines need to store it or keep it stopped for long periods. Among them we can point out:

- The growing need of industries to keep spare machines in stock so as to avoid long shutdowns for maintenance, and maintain their manufacturing processes in operation;
- The construction of new industrial plants or power generation plants that need to keep their machines stored until the beginning of operations;
- Long shutdowns for maintenance.

We can consider "long term storage" a situation in which a machine remains stopped for a period over two months and, therefore, already requires special maintenance care.

That's why companies are increasingly seeking information and planning not only the maintenance of machines in operation, but also of those that are stopped.

A good preventive maintenance plan can prevent many problems at the time of commissioning and start-up of machines stopped for long periods.

Machines with special construction features often require special care during storage.

Parts and accessories supplied separately from the machine also require special care when stored for long periods.

This article mentions constructive parts that require maintenance, the procedures to be adopted for maintenance during storage and care prior to start-up of induction motors, synchronous motors and generators, DC motors and generators, in horizontal and vertical mounting versions, used in different applications.

All inspections and procedures must be performed by experienced people with expertise and with deep knowledge on rotating electrical machines.



2 CONSTRUCTIVE PARTS

Figure 1 shows the cross section of an induction motor listing the main parts that are typically part of a rotating electric machine, as follows:

1. Frame
2. Stator
3. Rotor
4. Bearing
5. Shaft
6. Fans
7. Air-air heat exchanger



Figure 1: Parts of an induction motor

3 LONG STORAGE

When stored for a long period before startup, the machine is exposed to external influences, such as temperature variations, humidity, aggressive agents, etc.

The external machined parts, such as shaft and flanges, and voids inside the machine, such as in the bearings, in the terminal box and in the windings are exposed to those agents. As a result, after long periods of storage, the insulation resistance of the winding may decrease, bearings and machined parts may rust and the properties of the bearing lubricant may change.

All these influences increase the risk of malfunction or damage to the machine during start-up.

4 STORAGE LOCATION

Preferably, the rotating electrical machines must be stored in a closed, covered, clean and ventilated place free from moisture, corrosive agents, vibration and extreme temperature variations.

It is also necessary that the storage place have electric power for the space heaters.

The space around each stored machine must be enough to provide easy access for the maintenance operator to perform the required periodic inspections and tests.

5 EXTERNAL STORAGE

It is not recommended to store rotating electrical machines outdoors without cover, because the weather causes serious damage to this kind of equipment. If this situation cannot be avoided, some protective measures must be taken, such as placing the package on pallets or foundations to prevent it from sinking into the soil, completely covering the package with a canvas or tough plastic and providing a cover (roof) so as to avoid direct action of rain, sun, snow, dust, salt spray or other harmful agent.

6 INSPECTIONS

In order to keep the original features and prevent problems during start-up, the stored machines must be inspected periodically and records of the inspections should be filed.

6.1 INSPECTION OF THE PAINTING

Besides the aesthetic function, the painting also serves as a protection against corrosion.

The painting must be inspected periodically during the storage of the machine and repaired when necessary.

6.2 INSPECTION OF THE MACHINED PARTS

The exposed machined surfaces of the machines must be coated with an anticorrosive agent. This agent must remain on these surfaces until the installation of the machine, and reapplied whenever necessary.

In order to remove that protection during the installation of the machine, one uses specific alkyd diluent.



Figure 2: Anticorrosive product on machined parts

6.3 INSPECTION OF THE TERMINAL BOX

During periodic inspections of stored machines, the terminal boxes must be inspected in order to detect any signs of moisture, corrosion or faults in the sealing.

The cover sealing must not let moisture or dirt in the machine.

Inspect insulators, connectors and connecting bars of the conductors and replace those showing signs of cracks, broken pieces or other physical damages.

The terminal boxes that show signs of corrosion must be repaired or replaced before making any electrical connection.



Figure 3: Terminal boxes

6.4 INSPECTIONS OF THE BRUSHES

When the machine has electric brushes, they must be lifted in the brush holder or removed from the machine during the storage period, thus avoiding corrosion or marks on the slip rings or commutator. The slip rings must be covered with paraffin or a thin film of oil. It is important to remember to completely remove this protection before putting the machine into operation.



Figure 4: Brushes removed from the brush holder

7 CONSERVATION OF THE BEARINGS

The bearings have metal parts which have sliding contact and require exceptional condition for their proper operation and consequently of the machine. Therefore, it is one of the most important maintenance items during storage.

The ideal conservation condition of the bearing is when it is in operation, spinning and lubricating its components.

When not in operation, if the maintenance and conservation procedures are not observed, damage to the bearings may occur, which will only show at the start-up.

This chapter contains the main types of bearings, mounting positions and the care required during the storage period or stoppage of the machine.

7.1 TRANSPORTATION LOCK

In order to avoid damages to the bearings during the handling and transportation of the machines, a shaft lock must be used, like the example shown in Figure 5. This lock must be kept during storage and removed for the bearing maintenance procedures.

When the preventive procedure is finished up, if the machine remains stored, the shaft lock must be reinstalled and removed at the machine start-up.



Figure 5: Shaft lock



Figure 7: Oil-lubricated rolling bearing

7.2 BEARINGS OF HORIZONTAL MACHINES

7.2.1 ROLLING BEARINGS

Figure 6 shows a grease-lubricated rolling bearing and Figure 7 shows an oil-lubricated rolling bearing.

The rolling bearings are lubricated at the factory for tests on the machine and the lubricant must remain in the bearings throughout the storage period. If the oil-lubricated rolling bearings were transported without oil, they must be filled with the oil type and level specified by the manufacturer before the machine is stored.

In order to lubricate and preserve the internal parts of the bearings, it is recommended to spin the machine shaft 10 to 15 revolutions every 2 months. To do so, it is necessary to remove the shaft lock. After 6 months of storage, the bearings must be relubricated. After two years it is recommended to disassemble, wash, inspect and relubricate the bearings.

The bearing manufacturers recommend that sealed bearing – which cannot be relubricated – be replaced after 2 years of storage.



Figure 6: Grease-lubricated rolling bearing

7.2.2 HYDRODYNAMIC BEARINGS

The hydrodynamic bearings, also known as plain bearings or sleeve bearings, are lubricated at the factory for tests on the machine and the lubricant must remain in the bearings throughout the storage period.

If the bearings were transported without oil, they must be filled with the oil type and level specified by the manufacturer before the machine is stored. The conservation procedure of the hydrodynamic bearing during the storage period may vary according to the type of bearing. For the most common type, with oil tank and loose oil ring, the recommended procedure is to spin the shaft 10 to 15 revolutions at a speed of at least 30 rpm every 2 months.

The hydrodynamic bearings with dry crankcase and without loose oil ring require forced lubrication for their operation and also for the shaft spinning during storage. Thus, the external lubrication system or jacking system, if present, need to be connected for the spinning procedure.

If it is not possible to spin the machine shaft, it is recommended to disassemble the bearings, clean them and apply an anticorrosive compound on the bearing shells, contact surface of the shaft and internal parts of the bearing. It is also recommended to put dehumidifier bags (silica gel) inside to absorb humidity.

Reassemble the bearing and, to prevent the ingress of moisture and impurities, it is necessary to completely seal the bearing, closing the threaded holes and sealing the gaps between shaft and bearing with waterproof tape.

In order to preserve the internal parts of the bearing, this procedure must be repeated every 6 months of storage and after 2 years it is recommended to disassemble the bearing and preserve the parts.

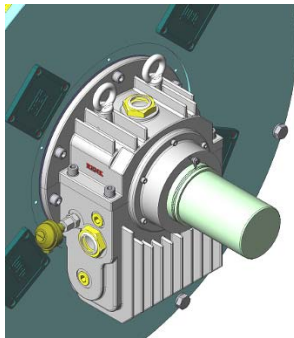

Figure 8: Hydrodynamic bearing

7.2.3 MACHINES WITH A SINGLE BEARING

For some specific applications, the electrical machine may have only the rear bearing, with the coupling done by shafts and flanges of the coupled machines.

Since the machine does not have front bearing, the shaft remains locked during the storage period and the lock is only removed at the installation.

If the rear bearing is a rolling bearing, it needs to be relubricated every 6 months and before start-up. It is also necessary an assessment of the conditions of the bearing before putting the machine into operation.

If the rear bearing is a hydrodynamic bearing, the bearing conservation is basically the protection of the bearing shells, shaft contact surface and bearing internal parts by applying an anticorrosive compound, using dehumidifiers and sealing the bearing, according to the procedure described in item 7.2.2. Before the start-up, the hydrodynamic bearing needs to be disassembled so as to assess the conditions of the bearing, especially the lower bearing shell, which was subject to the weight of the machine rotor.



Figure 9: Machine with single bearing

7.3 BEARINGS OF VERTICAL MACHINES

The types of bearings used in rotating electrical machines with vertical mounting depend on the size, characteristics of the electric machine and the characteristics of the machine coupled to it. The speed of the machine, the axial thrust imposed by the load and the direction are important factors for this definition.

The recommendations for maintenance of the bearings of vertical machines during storage vary according to the type of bearing, as follows:



Figure 10: Example of vertical electrical rotating

7.3.1 VERTICAL GREASE-LUBRICATED ROLLING BEARINGS

The conservation of grease-lubricated bearings mounted vertically is basically the lubrication of its internal parts, the spinning of the machine shaft 10 to 15 revolutions every 2 months and the relubrication every 6 months of storage. After 2 years of storage the regreaseable bearings must be disassembled, washed and relubricated, and sealed bearings must be replaced.

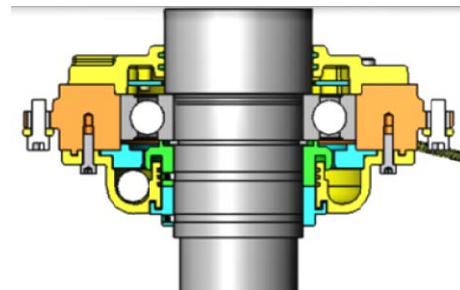

Figure 11: Upper grease-lubricated bearing

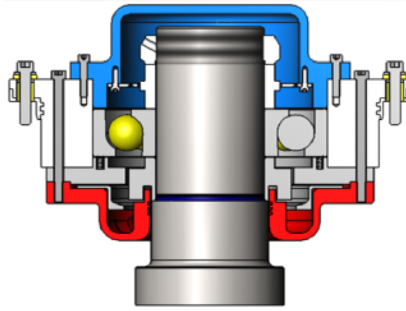

Figure 12: Lower grease-lubricated bearing

7.3.2 VERTICAL OIL-LUBRICATED ROLLING BEARINGS

On machines with rolling bearings submerged in oil, it is allowed to spin the shaft making oil circulate through contact parts.

The rolling bearings not submerged in oil require the contact parts to be lubricated before spinning the shaft.

When the bearings have oil self-pumping, the minimum speed for pumping oil must be observed; therefore, it is recommended that the machine be operated at rated speed for the oil to be pumped to the bearings and lubricate them.

The rolling bearings not submerged may also have lubrication forced through an external oil pump or oil mist system. For those cases the bearing lubrication system must be activated before spinning the machine shaft so as to keep the internal parts of the bearing lubricated.

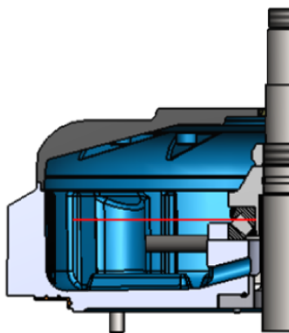

Figure 13: Vertical rolling bearing lubricated by oil - submerged

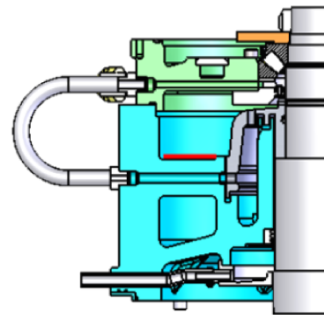

Figure 14: Vertical rolling bearing lubricated by oil bumping

7.3.3 VERTICAL HYDRODYNAMIC BEARINGS

Vertical machines with hydrodynamic bearings are usually composed of a guide/thrust bearing and another guide bearing. The rotor weight and load thrust are supported by shoes of the thrust and guide bearing.

During the storage period, before spinning the shaft, which must be done every two months to preserve the bearings, it is necessary that the rotor be lifted a few millimeters by using a lever or hydraulic jack so as to create the oil film between the shoes and the bearing runner.

If it is not possible to spin the machine shaft, it is recommended to disassemble the bearings, clean them and apply an anticorrosive compound. We also recommend the use of bags of dehumidifier (silica gel) inside the bearing to absorb humidity. Assemble the bearing again, closing the threaded holes and sealing the gaps between the shaft and bearing with waterproof tape so there is no penetration of dirt and moisture.

All flanges (e.g., oil inlet and outlet) must be sealed.

Repeat this procedure every 6 months, replacing also the dehumidifiers.

If the storage period is over 2 years, it is recommended to disassemble and preserve the bearing parts.

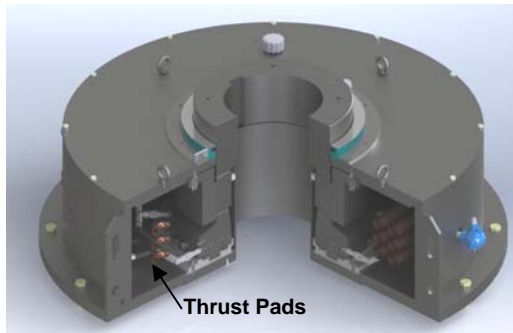

Figure 15: Vertical hydrodynamic bearing (thrust and guide)

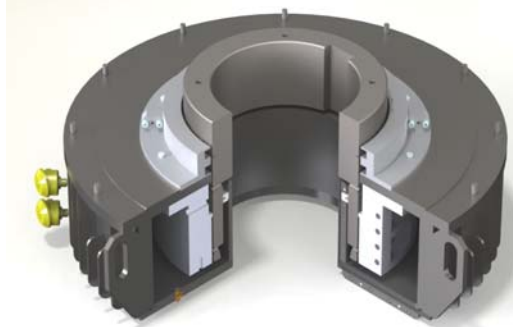

Figure 16: Hydrodynamic bearing (guide)

8 CONSERVATION OF THE INSULATION

8.1 INSULATION RESISTANCE

When an insulating material separates two conductors under the influence of a difference of potential, leakage currents appear. The insulation resistance corresponds to the resistance that the insulating material imposes to the passage of this leakage current, which can flow through the insulating mass or its surface.

8.2 EFFECT OF HUMIDITY ON THE INSULATION

Regardless how clean the winding surface is, if the winding temperature is below the dew point of the ambient air, a film of moisture may form on the surface of insulation, which can reduce the insulation resistance or polarization index. The effect is more evident if the surface is also contaminated, or if there are cracks in the insulation.

During the storage period, especially in environments with rapid changes of temperature, the inside of the machine must be maintained at a temperature 2 to 3°C above the ambient temperature so as to prevent water condensation within the machine. This can be achieved by connecting the space heater which is normally provided as an accessory of the machine.

If the machine has no space heater, incandescent light bulbs or another kind of heater may be used

inside the machine.

The drain, normally located in the lower part of the machine, must be periodically opened in order to remove possible condensed water.

8.3 CONTROL OF THE INSULATION RESISTANCE

The insulation resistance of the windings must be regularly measured during the storage of the machines so as to ensure that the humidity levels and other environmental factors will not damage the winding insulation.

The objective of controlling the insulation resistance during the storage period and before start-up is to identify when this resistance falls to a level at which an insulation fault may occur when the rated voltage is applied to the winding. Constant reductions in the values of the insulation resistance indicate the presence of humidity and/or dirt on the windings, and must be eliminated.

8.4 MEASUREMENT OF THE INSULATION RESISTANCE

The measurement of the insulation resistance is made with a specific device (megohmmeter) to measure high resistance in MΩ.

The high DC voltage imposed by the equipment will cause a small current flow (micro-amps) through the winding and insulation. The intensity of the electric current depends on the applied voltage, system capacitance, total electric resistance and temperature of the material. For a fixed voltage, the higher the current, the lower the resistance ($U=I.R$, $R=U/I$). The total resistance is the sum of the conductor internal resistance (small value) plus the insulation resistance in MΩ.

The value of the insulation resistance varies inversely, in an exponential base, to the winding temperature. Therefore, during the test of insulation resistance, the winding temperature must be recorded and the measured value of the insulation resistance must be converted to 40°C, according to the curve in Figure 17, provided by NBR 5383 / IEEE-43 standard.

The test voltages for the windings recommended by standard IEEE-43, are shown in Table 1:



Table 1: Test voltages

Rated voltage of the winding (V)	Insulation resistance test - continuous voltage (V)
< 1000	500
1000 - 2500	500 - 1000
2501 - 5000	1000 - 2500
5001 - 12000	2500 - 5000
> 12000	5000 - 10000

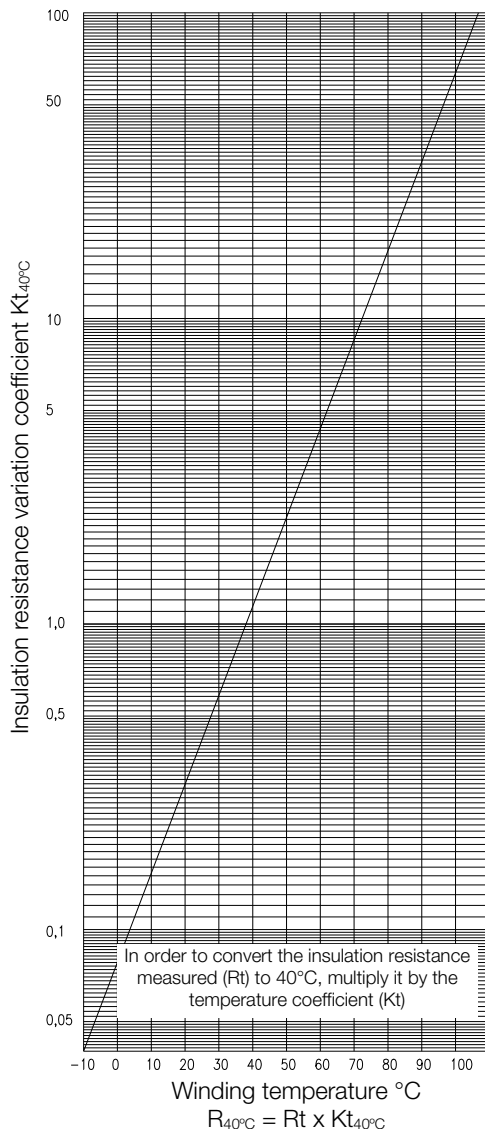

Figure 17: Insulation resistance variation coefficient according to the temperature

8.4.1 STATOR WINDINGS

In order to measure the insulation resistance of the machine stator windings, the megohmmeter must be connected between the machine frame and the stator terminals, as shown in the example in Figure 18, seeing that the frame must be grounded. This measurement is usually made directly in the machine terminal box.

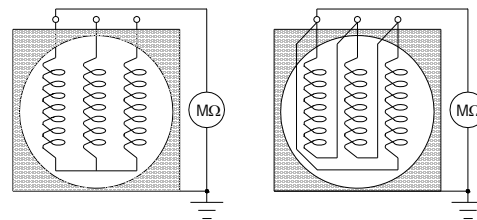

Figure 18: Megohmmeter connection

This test does not evaluate the integrity of the insulation between turns or between phases of the winding, but the insulation conditions of the winding in relation to the grounded part of the machine.

8.4.2 ROTOR WINDINGS

In order to measure the insulation resistance of the rotor winding of brushless synchronous machines (motors and generators), it is necessary to have access to the machine exciter. The measurement is made between the connecting cable of the rotor and machine shaft. In order to do so, it is necessary to loosen the rotor cables connected to the diode wheel of the exciter rotor.

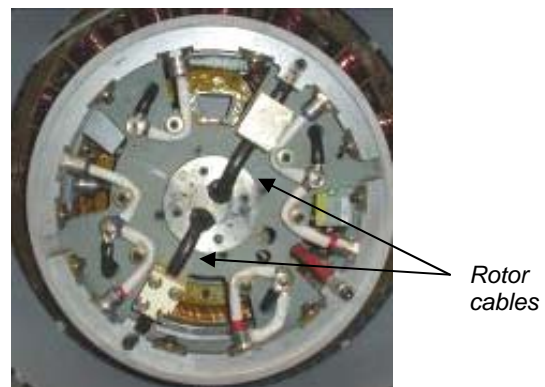

Figure 19: Example of diode wheel of a brushless synchronous machine

On machines that have slip rings (synchronous motors, synchronous generators and wound asynchronous motors), the measurement is made between the slip rings and the machine shaft. For this it is necessary to lift or remove all brushes.



Slip rings

Figure 20: Example of slip rings and brushes of a synchronous machine

On DC machines, the measurement is made between the commutator and the motor shaft, with the brushes lifted or removed from the machine.



Commutator

Figure 21: Commutator of a DC motor

8.4.3 EXCITER WINDINGS OF SYNCHRONOUS MACHINES

On brushless synchronous machines, the measurement of the insulation resistance of the stator windings of the main exciter and auxiliary exciter (PMG) can be made directly in the terminal box between the connecting terminals and the frame.

For measurement on the main exciter rotor, it is necessary to disconnect the cables from the main rotor winding connected to the diodes. Also loosen the connections of the exciter rotor winding to the diode wheel. The measurement is made between the wires or cables of the exciter rotor winding and the frame.

8.4.4 INSULATED COMPONENTS

As the windings are electrically insulated from the structural part of the machine, other components, such as insulators, brush holders and accessories (space heater, temperature sensors, etc.) are also insulated and need to be inspected during the storage so as to ensure that the insulation resistance is within the recommended values. The test voltages normally used for these

components are 500V for space heaters and brush holders and 100V for other accessories. (WEG criteria). The insulation resistance test with applied voltage is not recommended for the temperature sensors.

8.4.5 INSULATED BEARINGS

Some machines may have one or both bearings insulated. A good insulation on the bearing is necessary to eliminate the possibility of current flow through the bearing, which can be induced by voltages of the shaft in large machines.

The verification of the insulation resistance of the bearing is done at the factory during the final assembly and tests of the machine. During the storage of the assembled machine, the measurement of the insulation of the bearing can be performed only when both bearings are insulated. The measurement is made directly from each bearing to the shaft, taking care to remove the shaft grounding brush (if any).

In machines where only one of the bearings is insulated, it is not possible to measure the insulation resistance of the insulated bearing without the other bearing being disassembled and insulated. In those cases the measurement is recommended only when the machine is disassembled for maintenance.

The minimum insulation resistance recommended for insulated bearings is 10K.

8.5 POLARIZATION INDEX

Another method for determining the quality of the insulation of an electrical machine is the polarization index test (PI).

The polarization index is the ratio of two readings of time-resistance: one is made after 1 minute and another after 10 minutes as of the beginning of the test.

The results of the polarization index are obtained by dividing the test value of 10 minutes by the test value of 1 minute. A low value of polarization index indicates problems with the insulation. Item 8.7 shows the minimum value recommended for PI, according to the IEEE-43 standard.



8.6 DIELECTRIC ABSORPTION TEST

The time-resistance test can be done in electrical machines, regardless the size and temperature. The test voltage is applied for a 10 minutes, with the data recorded every 10 seconds from the first to the last minute. The interpretation of the insulation resistance versus time curve determines the insulation condition.

When the insulation is good, the insulation resistance starts low and increase as the capacitive leakage current decreases, as in the curve shown in Figure 22. This test is particularly useful to determine the degree of humidity and ingress of oil which generate leakage currents and occasionally short-circuits on circuits, causing a flattening effect on the dielectric absorption curve shown in Figure 22.

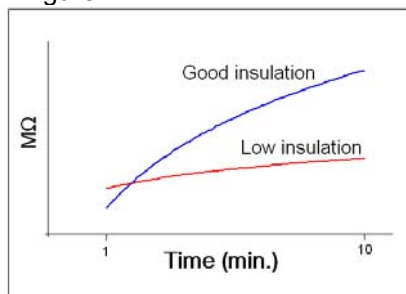

Figure 22: Dielectric absorption

8.7 EVALUATION OF THE INSULATION

According to IEEE-43 standard, the minimum value recommended for the insulation resistance and polarization index on rotating electrical machines, converted to 40°C, must be considered according to Table 2:

Table 2: Minimum values of IR and PI

Tested winding	RI1min
Manufactured up to 1970	kV + 1
Manufactured after 1970	100MΩ
Windings in general with kV < 1.	5MΩ
Minimum polarization index (PI) = 2	

8.8 DRYING METHODS FOR THE WINDINGS

8.8.1 PREMISES

If the insulation resistance measured is below the recommended values in Table 2 and the cause for this is humidity, the windings must undergo a drying procedure.

The final temperature recommended for drying insulated windings is 120°C.

In all drying procedures, the insulation resistance and the temperature of the windings must be monitored throughout the process. The winding

temperature must not exceed the maximum temperature of the insulation class and the procedure can be finished when the values of insulation resistance become constant.

8.8.2 DRYING IN AN OVEN

The drying of the winding in an oven requires the machine to be disassembled and only the part where the winding (rotor, stator, etc.) is must undergo the drying process.

The temperature must be gradually increased until the desired value is reached and the recommended increase in temperature is at most 30°C per hour.

In order to avoid the formation of steam inside the winding, it is recommended to keep the temperature of 80°C for about 6 hours before reaching the maximum drying temperature (120°C).

8.8.3 DRYING WITH INTERNAL ELECTRIC HEATERS

The process is to apply heat inside the machine frame, without the need of disassembling it, by means of light bulbs or electric heaters and direct a fan or exhaust fan to the coil to remove the moisture.

Radiant heaters that generate heat by infrared waves are not recommended for this process because some parts of the windings may overheat and burn before other parts of the winding reach the required temperature.

8.8.4 DRYING WITH FORCED HOT AIR

In order to dry the winding using forced hot air, it is necessary to build a system with duct and electrical heaters.

This device is installed in one of the machine air inlet (open machines) or through one of the openings for inspection (closed machines), while the opposite side must have an opening for the air exit.

Hot air is blown into the machine, which passes through the windings drying and removing the humidity.

In this process, it is not necessary to disassemble the machine.



8.8.5 DRYING BY ELECTRICAL CURRENT CIRCULATION

One of the most effective means of drying the windings of an electric machine is the circulation of current through the windings.

One of the recommended methods is applying a voltage to the terminals of the winding through a source of DC voltage (12 or 24 VDC) with high-current capacity and voltage adjustment (welding machines are normally used).

Alternate current sources can also be used, but only when it is possible to remove the rotor from the inside of the machine so as to prevent its excessive heating.

In synchronous motors and generators, the current circulation can be done with the machine working as a generator and the terminals of the stator windings connected in short circuit.

8.8.5.1 DRYING OF THE STATOR WINDINGS

The process of drying the stator windings of rotating electrical machines in general (motors and generators) can be done with the machine stopped without disassembling it.

The windings must be connected in series so that the same current flows through all the windings. The DC voltage must be applied to the windings and slowly raised until it reaches around 15% to 25% of the rated current of the winding. Keep the voltage at this level and monitor the temperature rise by means of the temperature sensors. When the winding temperature stabilizes, increase the voltage gradually, such that the temperature increment is around 30°C per hour.

When 80°C is reached, keep this winding temperature for approximately six hours and then raise it up to the maximum drying temperature (120°C), maintaining it for two or three more hours until the winding is completely dry.

On three-phase windings with only three accessible terminals, the application of current must be done between one of the phases and the other two connected in parallel, changing the phases every one hour. The phase connected alone will have twice the current of the other two and its temperature must be preferably monitored and controlled.

8.8.5.2 DRYING BY THE SHORT CIRCUIT METHOD

Specifically for synchronous machines (motors and generators), one of the simplest and most economical winding drying methods can be used. In order to do so, the machine must be driven by the primary machine (turbine, diesel engine etc.)

running under normal speed, bearing lubrication and cooling operating conditions, but with no load. The stator terminals are connected in short circuit and the excitation (field) is gradually activated in the manual mode, so that the stator current also increases gradually.

Like the other procedures, the ideal temperature increase to dry the winding is 30°C per hour, and, in order to do so, the procedure must start with the stator current around 15% to 25% of the rated current of the winding, increasing gradually.

The winding temperature must be monitored through the temperature sensors and must not exceed 120°C at the end of the process.

This method is quite effective, since it allows drying both the stator and rotor of the machine. With the rotor spinning, the air circulates inside and helps expelling the humidity from the machine.

8.8.5.3 DRYING OF THE ROTOR WINDINGS

In order to perform the drying by current circulation on rotor windings of synchronous generators and motors, which do not feature sensors to monitor the temperature, it is necessary to calculate the winding temperature during the drying process. By making a precise record of the winding ohmic resistance and temperature before beginning the procedure, it is possible to calculate the average temperature of the winding through a precise measurement, at regular time intervals, of the electric current and DC voltage applied during the drying process, as follows:

- Calculation of the winding ohmic resistance:
 $Re = Vdc / Idc$

Where

Re = Winding resistance in Ω

Vdc = Applied voltage in V

Idc = Direct current measured in A

- Calculation of the average temperature of the winding:

$$Te = [(Re-R1) / R1]. (235+t1) + t1 \text{ [}^\circ\text{C]}$$

Where:

Te = average temperature of the winding [$^\circ\text{C}$];

t1 = winding temperature before the procedure (practically the same as that of the cooling medium) [$^\circ\text{C}$];

R1 = ohmic resistance of the winding measured before the procedure [Ω];

Re = ohmic resistance of the winding measured during the procedure [Ω];

Measure the insulation resistance at the end of the drying process, making sure it is within the values recommended by the IEEE-43 standard.



The voltage must not be applied through the slip rings, but directly to the rotor winding cables.

This procedure is not used for wound rotors of induction motors (wound-rotor motors) and DC motors.

8.8.5.4 CARES IN THE DRYING OF WINDINGS BY CURRENT CIRCULATION

Pay careful attention to the following aspects of the drying process by current circulation:

- Each machine has specific characteristics. Therefore, before starting the drying process, the manufacturer of the machine must always be consulted in order to define the criteria to execute the procedure (voltage, current temperature), etc.
- The process must only be done when it is observed that the humidity on the windings is the cause of the low insulation of the machine.
- When the winding is very humid, first a pre-drying must be done with force hot air.
- In no phase of the process shall the temperature on the windings exceed the maximum process temperature (120°C).
- The temperature increments on the winding shall not exceed 30° per hour.
- When 80°C is reached, keep this winding temperature for approximately six hours and then raise it up to the maximum drying temperature (120°C), maintaining it for two or three more hours until the winding is completely dry.
- The job must be done by experienced people and with deep knowledge on the process, since the incorrect application of current or improper control of the winding temperature may cause damages or even the complete burn of the winding.

9 PREPARATION FOR START-UP

In order to ensure the good operation of an electrical rotating machine which remained stored or stopped for a long period, some procedures must be observed before starting it:

- The machine must be removed from the package carefully, avoiding damages to the paint or to the external machined parts;
- Inspect the machine externally, especially the paint, machined parts, flanges, shaft;
- Clean all the machine and remove the anticorrosive agent from the external machined parts;

- The bearings must be inspected and lubricated before the start-up;
- The insulation resistance of the windings must be measured and comply the minimum values recommended by the IEEE-43 standard.
- In machines with brushes, inspect the slip rings or commutator and put the brushes back on the brush holders, making sure they can move freely inside their compartment.
- Check the operation of all accessories;
- The shaft lock must be removed and kept to be used when the machine needs to be transported.

10 EXAMPLES OF PROBLEMS ON MACHINES STORED WITHOUT THE PROPER CARE

The examples below try to show some problems occurred on rotating electrical machines stored or stopped for long periods without the proper care.



Figure 23: Static corrosion on the external track of the bearing

Figure 23 shows a rolling bearing with significant corrosion marks. The corrosion of the rolling bearing may happen because the lubricant does not contain proper rust and corrosion inhibitors to protect the metal surfaces or because of the lack of lubrication of the metal parts when the moving parts of the roller bearing remain static for a long time (without spinning).



Figure 24: Surface marks (false brinelling)

Figure 24 shows the internal track of a rolling bearing with equidistant surface marks. This kind of fault is caused by the vibration of the rolling bearing in a static position, which makes the rolling elements vibrate against the track in a single place and, after some time, it may even remove small pieces of metal surfaces.



Figure 25: Marks on the bearing shell

Figure 25 shows the fault on the lower bearing shell of a hydrodynamic bearing caused by the weight of the shaft. This kind of fault occurs when the shaft remains static for a long period, without the formation of the oil film between the sliding surfaces of the shaft and the bearing shell.



Figure 26: Humidity on the windings

Figure 26 shows the windings with drops formed by water condensation within the machine. This kind of fault occurs when the storage environment presents significant temperature variations and space heaters are not used to keep the internal temperature of the machine above the ambient temperature. The humidity reduces the insulation resistance of the windings.



Figure 27: Corrosion on the shaft

Figure 27 shows the shaft with significant signs of rust and corrosion. This occurs when the machined part is exposed to a humid or contaminated environment without any kind of anticorrosive protection.

11 RECOMMENDATIONS

The unpleasant surprises caused by faults presented during commissioning and start-up of rotating electrical machines can and must be prevented with proper inspection and maintenance procedures during the storage period.

A good maintenance plan during the storage must encompass visual inspections, cleaning, insulation resistance and polarization index tests, bearing conservation, connection of the space heater, inspection of the paint and exposed machined parts, application of anticorrosive compounds, and other procedures informed by the manufacturer of the machine.



12 CONCLUSION

The kinds of rotating electrical machines vary significantly according to their size, components, mounting, application and operation.

Preserving due proportions and specialties, all rotating electrical machines need care both in the storage and start-up.

The topics presented in this article offer orientation and recommendations for the correct storage of the main kinds of medium-sized rotating electrical machines. However, it is also necessary that the specific characteristics of each machine and the instructions of the manufacturer be evaluated and carefully observed.

13 REFERENCES

- [1] IEEE-43 – Recommended Practice for Testing Insulation Resistance of Rotating Machinery, New York, Institute of Electrical and Electronics Engineers, 2000.
- [2] Fowle, Frank Fuller; Knowlton, A. E. Standard Handbook for Electrical Engineers, 7th edition, Washington.
- [3] Storage of Electric Motors, IEEE, 1995.
- [4] Electric Motor Storage: Protecting Your Investment, IEEE, 2011.
- [5] Teste de Resistência de Isolação – Fluke / Vortex.
- [6] Guide to Electric Motor Bearing Lubrication – Exxon Mobil, catalog nr. 02-F2003767, USA, 2002.