

**ADDENDUM TO THE
CFW-08 FREQUENCY
INVERTER USER
MANUAL**



User's Guide

CONTENTS

- 1. Quick Parameter Reference 04
- 2. Block Diagram (User Manual Item 2.3) 05
- 3. Mounting Specifications (User Manual Item 3.1.2) 06
- 4. Positioning and Fixing (User Manual Item 3.1.3) 07
- 5. Panel Mounting (User Manual Item 3.1.3.1) 07
- 6. Location of Power Terminals, Grounding Terminals and Control
 - Terminals Connections (User Manual Item 3.2.2) 08
- 7. Wiring and Circuit-Breakers for the Power and Grounding
 - Connections (User's Guide Item 3.2.3) 08
 - 7.1 Wiring and Circuit-Breakers 08
 - 7.2 Fuses (Branch Circuit Protection) 09
- 8. Recommended Tightening Torque (User Manual Item 3.2.3) 09
- 9. Power Connections (User Manual Item 3.2.4) 09
- 10. Line Reactor (User Manual Item 8.19) 10
- 11. Dynamic Braking (User Manual Item 8.21) 10
- 12. Technical Specification (User Manual Item 9.1) 11
- 13. WEG High Efficiency IV Pole Motor Data (User Manual Item 9.3) 11

ATTENTION: INFORMATION PRESENTED IN THIS ADDENDUM APPLIES ONLY TO 500-600V POWER SUPPLY CFW-08 MODELS

A new software version (V4.2x) was developed, to the 500-600V power supply new models (1.7A, 3.0A, 4.3A, 7.0A, 10A and 12A/500-600V) . This new software was created from V4.1X with the following modifications:

1. Quick Parameter Reference

Parameter	Function	Adjustable Range	Factory Setting	Unit	User Setting	Page
P004	DC Link Voltage	0 a 1000	-	V		91
P007	Motor Voltage	0 a 700	-	V		91
P136	Manual Torque Boost (IxR Compensation)	0.0 a 30.0	2.0	%		96
P151	DC Link Regulation Level	575V models: 809 to 1000	972	V		100
P295	Rated Inverter Current (Inom)	300 = 1.0A 301 = 1.6A 302 = 2.6A 303 = 2.7A 304 = 4.0A 305 = 4.3A 306 = 6.5A 307 = 7.0A 308 = 7.3A 309 = 10A 310 = 13A 311 = 16A 312 = 22A 313 = 24A 314 = 28A 315 = 30A 316 = 33A 317 = 1.7A 318 = 3.0A 319 = 12A	According to the inverter model	-		121

Table 1 – 575V Models parameters

2. Block Diagram (User Manual Item 2.3)

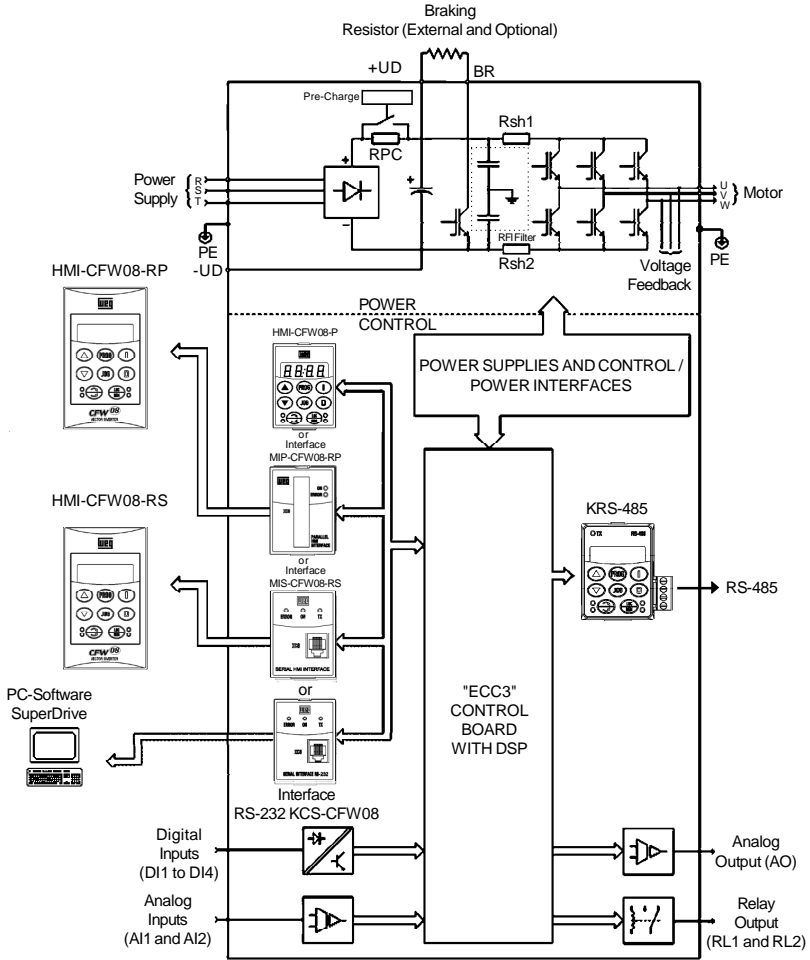

Figure 1 - Block diagram for the models:
1.7-3.0-4.3-7.0-10-12A/500-600V

3. Mounting Specifications (User Manual Item 3.1.2)

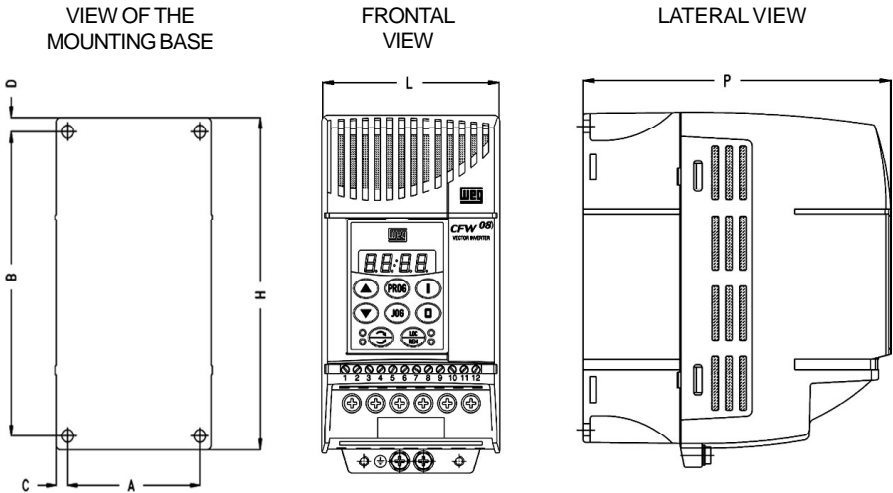

Figure 2 – CFW-08 Mounting Specifications

Inverter Model	Dimensions			Fixing Base				Mounting Screw	Weight Kg (lb)	Degree of Protection
	Width L mm (in)	Height H mm (in)	Depth P mm (in)	A mm (in)	B mm (in)	C mm (in)	D mm (in)			
1.7A / 500-600V	143 (5.63)	203 (7.99)	165 (6.50)	121 (4.76)	180 (7.09)	11 (0.43)	10 (0.39)	M5 (3/16)	2.5 (5.5)	IP20/NEMA1
3.0A / 500-600V	143 (5.63)	203 (7.99)	165 (6.50)	121 (4.76)	180 (7.09)	11 (0.43)	10 (0.39)	M5 (3/16)	2.5 (5.5)	IP20/NEMA1
4.3A / 500-600V	143 (5.63)	203 (7.99)	165 (6.50)	121 (4.76)	180 (7.09)	11 (0.43)	10 (0.39)	M5 (3/16)	2.5 (5.5)	IP20/NEMA1
7.0A / 500-600V	143 (5.63)	203 (7.99)	165 (6.50)	121 (4.76)	180 (7.09)	11 (0.43)	10 (0.39)	M5 (3/16)	2.5 (5.5)	IP20/NEMA1
10A / 500-600V	143 (5.63)	203 (7.99)	165 (6.50)	121 (4.76)	180 (7.09)	11 (0.43)	10 (0.39)	M5 (3/16)	2.5 (5.5)	IP20/NEMA1
12A / 500-600V	143 (5.63)	203 (7.99)	165 (6.50)	121 (4.76)	180 (7.09)	11 (0.43)	10 (0.39)	M5 (3/16)	2.5 (5.5)	IP20/NEMA1

Table 2 – CFW08 dimensions for mechanical installation of the 500-600V models

4. Positioning and Fixing (User Manual Item 3.1.3)

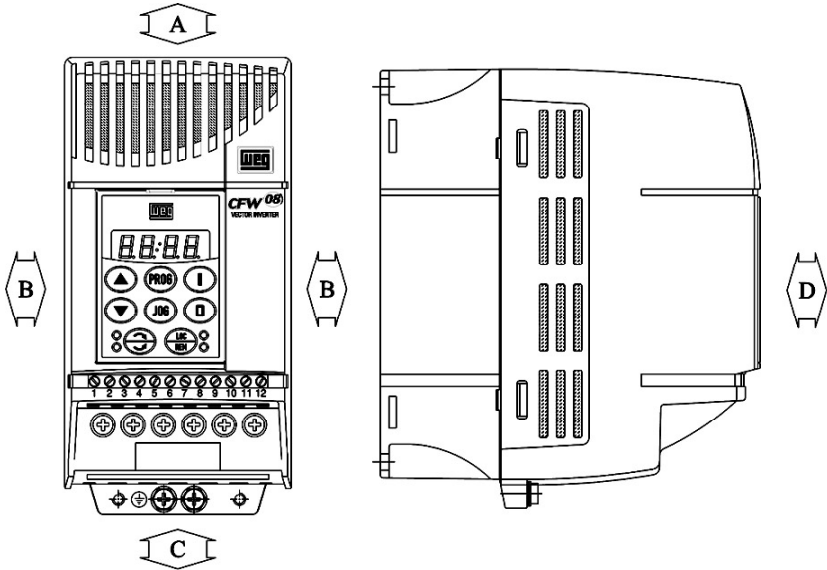

Figure 3 – Free spaces for cooling

Inverter Model	A		B		C		D	
1.7A / 500-600V	40mm	1.57in	30mm	1.18in	50mm	2in	50mm	2in
3.0A / 500-600V	40mm	1.57in	30mm	1.18in	50mm	2in	50mm	2in
4.3A / 500-600V	40mm	1.57in	30mm	1.18in	50mm	2in	50mm	2in
7.0A / 500-600V	40mm	1.57in	30mm	1.18in	50mm	2in	50mm	2in
10A / 500-600V	40mm	1.57in	30mm	1.18in	50mm	2in	50mm	2in
12A / 500-600V	40mm	1.57in	30mm	1.18in	50mm	2in	50mm	2in

Table 3 – Recommended free spaces

5. Panel Mounting (User Manual Item 3.1.3.1)

Inverter Model	CFM	l/s	m3/min
1.7A, 3.0A, 4.3A, 7.0A, 10A and 12A /575V	22.0	10.4	0.62

Table 4 – Cooling air flow requirements

6. Location of Power Terminals, Grounding Terminals and Control Terminals Connections (User Manual Item 3.2.2)

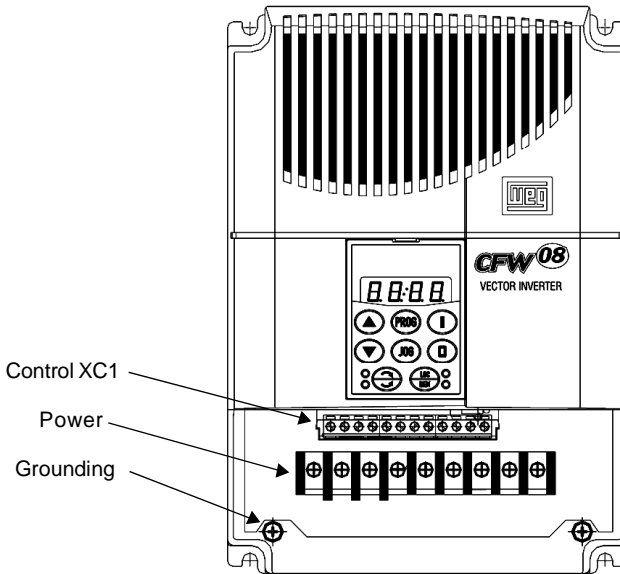

Figure 4 – Models: 1.7-3.0-4.3-7.0-10-12A/500-600V

7. Wiring Circuit-Breakers and Fuses for the Power and Grounding Connections (User Manual Item 3.2.3)

7.1 Wiring and Circuit-Breakers

Rated Inverter Current [A]	Power Cables [mm ²]	Grounding Wiring [mm ²]	Maximum Power Cables [mm ²]	Maximum Grounding Wiring [mm ²]	Circuit Breaker (Optional)	
					Current	WEG Model
1.7A / 500-600V	1.5	2.5	4.0	4.0	2.5	MPW25-2.5
3.0A / 500-600V	1.5	2.5	4.0	4.0	4.0	MPW25-4.0
4.3A / 500-600V	1.5	2.5	4.0	4.0	6.3	MPW25-6.3
7.0A / 500-600V	2.5	2.5	4.0	4.0	10	MPW25-10
10A / 500-600V	2.5	2.5	4.0	4.0	16	MPW25-16
12A / 500-600V	2.5	2.5	4.0	4.0	18	MPW25-20

Table 5 – Recommended wiring and circuit-breakers – use only copper wire (70°C)

7.2 Fuses (Branch Circuit Protection)

Reated Inverter Current [A]	UL Class J Fuses [A]	Fuse I ² t @25°C (A ² s)
1.7A / 500-600V	15	4000
3.0A / 500-600V	15	4000
4.3A / 500-600V	15	4000
7.0A / 500-600V	15	4000
10A / 500-600V	15	4000
12A / 500-600V	25	5500

Table 6 - Recommended fuses

8. Recommended Tightening Torque (User Manual Item 3.2.3)

Inverter Model	Grounding Wiring		Power Cables		Screw type
	N.m	Lbf.in	N.m	Lbf.in	
1.7A / 500-600V	0.5	4.34	1.0	8.68	Philips N° PH2/fenda
3.0A / 500-600V	0.5	4.34	1.0	8.68	Philips N° PH2/fenda
4.3A / 500-600V	0.5	4.34	1.0	8.68	Philips N° PH2/fenda
7.0A / 500-600V	0.5	4.34	1.0	8.68	Philips N° PH2/fenda
10A / 500-600V	0.5	4.34	1.0	8.68	Philips N° PH2/fenda
12A / 500-600V	0.5	4.34	1.0	8.68	Philips N° PH2/fenda

Table 7 – Recommended tightening torque for power and grounding connections

9. Power Connections (User Manual Item 3.2.4)

Models: 1.7-3.0-4.3-7.0-10-12A/500-600V – Three Phase Power Supply.

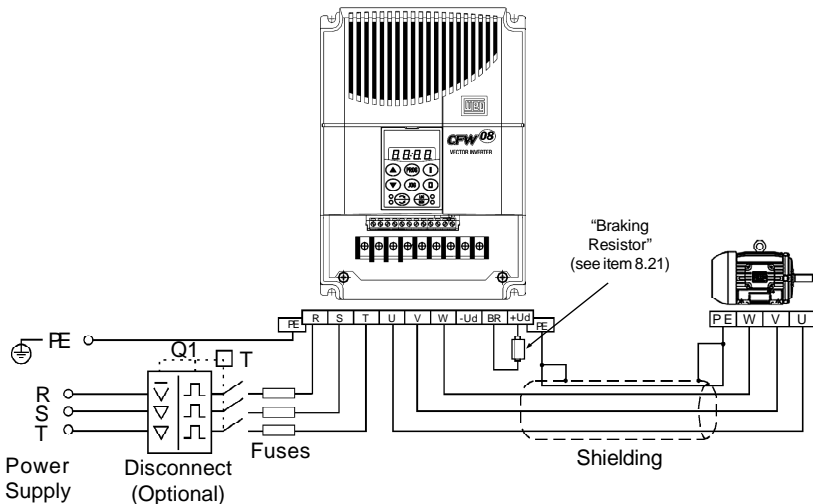

Figure 5 – Power Connections

10. Line Reactor (User Manual Item 8.19)

Inverter Model	Minimum Line Impedance		
	With rated load at the inverter output (Is = Isnom)	With 80% of the rated load (Is = 0.8.Isnom)	With 50% of the rated load (Is = 0.5.Isnom)
1.7A / 500-600V	0.25%	0.1%	0.05%
3.0A / 500-600V	0.5%	0.25%	
4.3A / 500-600V	0.5%	0.25%	
7.0A / 500-600V	0.5%	0.25%	
10A / 500-600V	1.0%	0.5%	
12A / 500-600V	1.0%	0.5%	

Table 8 – Minimum network impedance for several load conditions

As an alternative criterion, we recommend to add a line reactor always the transformer that supplies the inverter has rated output higher than indicated in the table below.

Inverter Model	Transformer Apparent Power [kVA]
1.7A / 500-600V	30 x rated inverter apparent power [kVA]
3.0A / 500-600V	10 x rated inverter apparent power [kVA]
4.3-7.0-10 / 500-600V	7.5 x rated inverter apparent power [kVA]
12A / 500-600V	4 x rated inverter apparent power [kVA]

Table 9 – Alternative criteria for use of line reactor – Maximum values of the transformer power

11. Dynamic Braking (User Manual Item 8.21)

Inverter Model	Maximum Braking Current	P _{max} (Maximum Resistor Power)	RMS Braking Current (*1)	P _{rated} (Rated Resistor Power)	Recommended Resistor	Recommended Wiring
1.7A / 500-600V	1,2	1,2kW	0,6	0,3kW	825	1.5mm ² / 16 AWG
3.0A / 500-600V	2,6	2,6kW	1,3	0,7kW	392	1.5mm ² / 16 AWG
4.3A / 500-600V	4,0	4,0kW	2,0	1,0kW	249	1.5mm ² / 16 AWG
7.0A / 500-600V	6,0	5,9kW	3,0	1,5kW	165	1.5mm ² / 16 AWG
10A / 500-600V	9,0	8,9kW	4,5	2,2kW	110	2.5mm ² / 14 AWG
12A / 500-600V	12,2	12,2kW	6,1	3,1kW	82	2.5mm ² / 14 AWG

Table 10 - Recommended braking resistors

(*1) The rms braking current can be determined by:

$$I_{rms} = I_{max} \times \sqrt{\frac{t_{br} [\text{min}]}{5}}$$

where t_{br} corresponds to the sum of the braking times during the most severe 5 minute cycle.

12. Technical Specification (User Manual Item 9.1)

500-600V Power Supply:

Model: Current (A)/Voltage(V)	1.7/ 500-600	3.0/ 500-600	4.3/ 500-600	7.0/ 500-600	10/ 500-600	12/ 500-600
Power (kVA)	1.7	3.0	4.3	7.0	10	12
Rated output current (A)	1.7	3.0	4.3	7.0	10	12
Maximum output current (A)	2.6	4.5	6.5	10.5	15	18
Power Supply	Three-phase					
Rated input current (A)	2.1	3.7	5.2	8.5	12.2	14.6
Switching frequency (kHz)	5	5	5	5	5	5
Maximum motor power	1HP/ 0.75kW	2HP/ 1.5kW	3HP/ 2.2kW	5HP/ 3.7kW	7.5HP/ 5.5kW	10HP/ 7.5kW
Dynamic Braking	Yes					
Internal class A RFI filter (optional)	No					
Footprint class A RFI filter (optional)						
External class B RFI filter (optional)						
Watt Loss (W)	40	70	100	160	230	280
Dimensions (Height x Width x Depth)	203x143x165mm					

Table 11 – Technical information about the inverter 500-600V models

13.WEG High Efficiency IV Pole Motor Data (User Manual Item 9.3)

Power [P404]		Frame	Voltage [P400] (V)	Current [P401] (A)	Frequency [P403] (Hz)	Speed [P402] (rpm)	Efficiency at rated load. η [P399] (%)	Power Factor at Rated Load. $\cos \phi$ [P407]	Stator Resistance [P409]
(CV)	(kW)								
1	0.75	143T	575	1.19	60	1765	82.5	0.77	15.07
2	1.5	145T		2.16		1750	84.0	0.83	8.08
3	2.2	182T		3.12		1765	87.5	0.81	9.57
5	3.7	184T		5.18		1750	87.5	0.82	5.95
7.5	5.5	213T		7.62		1765	89.5	0.81	4.57
10	7.5	215T		10.2		1760	90.2	0.82	2.93

Table 12 - Weg motor data



0899.5584_E2



www.weg.net