

APS9 ALL PURPOSE SOFT STARTER PANEL



APS9 (All Purpose Soft Starter Panel)

The WEG All Purpose Soft Starter (APS9) is designed to meet a wide range of soft starting application needs, having ratings for both the most demanding Heavy Duty (HD) applications and standard Normal Duty (ND) applications. The 1.15 service factor and 65kaic interrupting rating coupled with an outdoor friendly heavy duty, white, UL Type 12/3R/4 enclosure, make the APS9 suitable to install anywhere, indoor or outdoor, including wash down locations. The full start rated (AC3) bypass starter provides direct on-line starting in emergency situations. The full suite of door operators, and Bluetooth keypad provides all the options you will need to meet any control situation. From rock crushers to irrigation pumps, the APS9 is your one solution for all critical starting applications.



Standard Features

- Built with WEG Next generation new SSW900 soft starter.
- Rated for 65KA SCCR as a standard.
- Input voltage: 208/230/460VAC. (460VAC as a standard. CPT wiring modification needed for 208 or 230VAC input voltage).
- Dual duty rated soft starter panel, unique concept in the market:
 - Normal Duty: 350% for 30s. 1.00 SF.
 - Heavy Duty: 450% for 30s. 1.15 SF.
- UL 3R/4/12 rated White heavy duty rated enclosure suitable for dusty, wet or outdoor applications.
- Narrow design requires less space, floor mounting of enclosure available with optional leg kit.
- Main 65KA rated Circuit Breaker with through the door rotary handle.
- Service Entrance Rated.
- Full HP rated AC3 emergency bypass contactor with Class-30 overload relay helps to start and run the motor across the line in case of soft starter failure.
 - “Soft Starter-off-Bypass” selector switch mounted inside an enclosure.
- Fused Control Power Transformer (208/230/460VAC - 120VAC).
- Electronic circuit board with wire harnesses to replace most of the control wiring; makes it easier and faster to replace the components.
- Termination for customer supplied remote Start/Stop & External interlock dry contacts.
- “Motor running” and “system fault” dry contacts available for customer use.
- Enclosure door mounted:
 - SSW900 Soft starter graphical keypad with RTC, “Help” Menu, USB port & built-in Bluetooth (Bluetooth allows easy programming & monitoring of SSW900 using Cell phone app “WEG WPS”)
 - “Hand-Off-Auto” Selector switch.
 - “Start” illuminated (Run light) PB, “Stop” PB, E-stop PB, “SSW Reset” Illuminated (System Fault light) PB.
 - Power On, Bypass Enabled & External interlock disabled Pilot lights.

APS9 Catalog Number Sequence

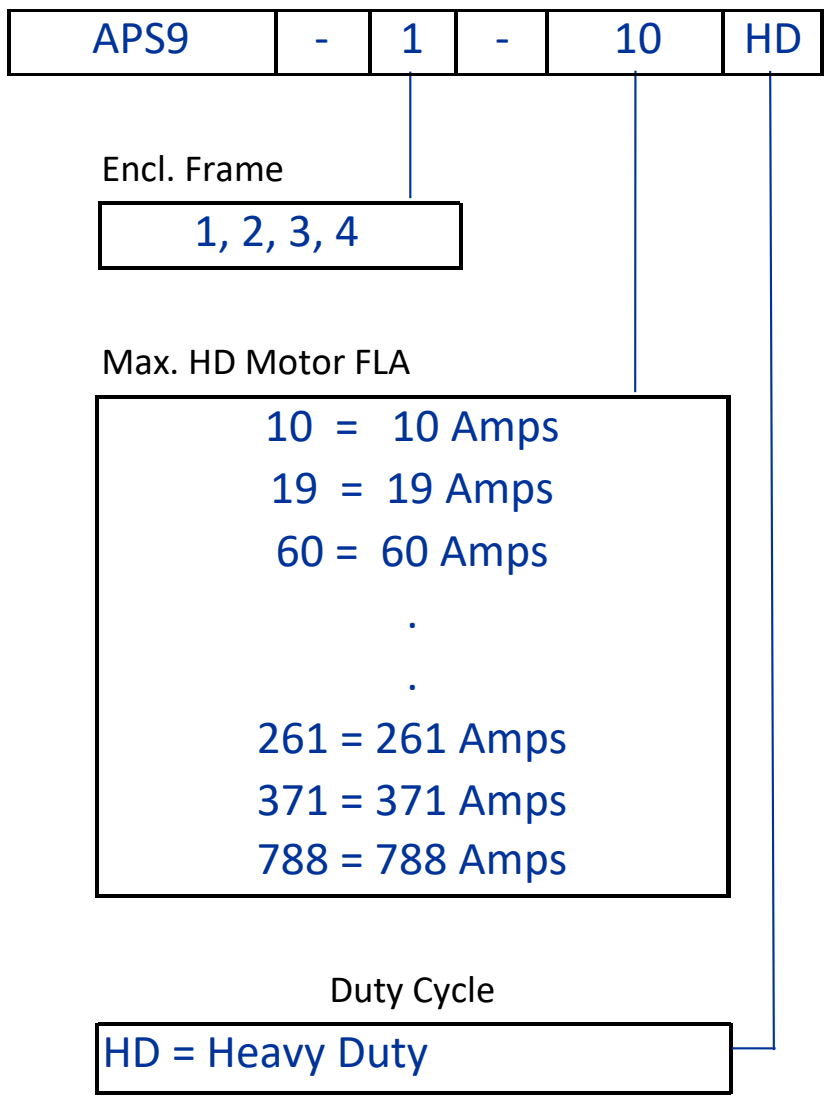

APS9-UL TYPE 12/3R/4 Enclosure

HEAVY DUTY (H.D.) ¹ - 1.15 SF 450% FLA for 30 Seconds				NORMAL DUTY (N.D.) ² - 1.00 SF 350% FLA for 30 Seconds				CATALOG NUMBER	ENCLOSURE FRAME	APPROX. WEIGHT (LB)
H.D.-MAX. MOTOR FLA	MOTOR HP ³			N.D.-MAX. MOTOR FLA	MOTOR HP ³					
	460VAC	230VAC	208VAC		460VAC	230VAC	208VAC			
10	5	3	2	10	5	3	2	APS9-1-10HD	1	150
19	10	5	5	22	15	7.5	5	APS9-1-19HD		150
31	20	10	10	40	30	10	10	APS9-1-31HD		155
43	30	15	10	55	40	20	15	APS9-1-43HD		155
60	40	20	20	77	60	25	25	APS9-1-60HD		155
77	60	25	25	97	75	30	30	APS9-1-77HD		155
96	75	30	30	120	100	40	40	APS9-1-96HD		155
125	100	40	40	161	125	60	50	APS9-1-125HD		175
156	125	60	50	180	150	60	60	APS9-2-156HD	2	210
185	150	60	60	238	200	75	75	APS9-2-185HD		230
261	200	100	75	300	250	100	100	APS9-3-261HD	3	275
302	250	100	100	383	300	150	125	APS9-3-302HD		310
371	300	150	125	477	400	150	150	APS9-3-371HD⁴		360
481	400	200	150	619	500	250	200	APS9-4-481HD	4	975
551	450	200	200	708	600	250	-	APS9-4-551HD		975
616	500	250	-	792	700	300	-	APS9-4-616HD		1060
788	700	300	-	960	800	400	-	APS9-4-788HD		1060

NOTES:

- H.D. = Heavy Duty (450% for 30s), 1.15 S.F. Application Example Crusher, Conveyor, Shredder, Chipper, Ball/Hammer Mil etc.
- N.D. = Normal Duty (350% for 30s), 1.0 S.F.
- The above "HP" ratings are based on motor FLAs as listed in NEC Table 430-150. Please select the APS9 panel by comparing actual motor FLA with "Max. Motor FLA" for a given voltage & application type (HD/ND).
- All APS9 panels are rated for 65KA SCCR except "APS9-3-371HD" which is rated for 18KA SCCR. This model will be upgraded to 65KA SCCR soon.

APS9-ACCESSORIES

Type	Catalog Number	Description
Leg kit for floor mounting	WENCL-ESL16-06-00	6" Tall Leg kit for APS9 enclosure frame-1 or 3, supplied loose
	WENCL-ESL18-06-00	6" Tall Leg kit for APS9 enclosure frame-2, supplied loose
	WENCL-ESL16-12-00	12" Tall Leg kit for APS9 enclosure frame-1 or 3, supplied loose
	WENCL-ESL18-12-00	12" Tall Leg kit for APS9 enclosure frame-2, supplied loose

APS9 ENCLOSURE FRAME SIZE:

Enclosure Frame: 1, 2 & 3

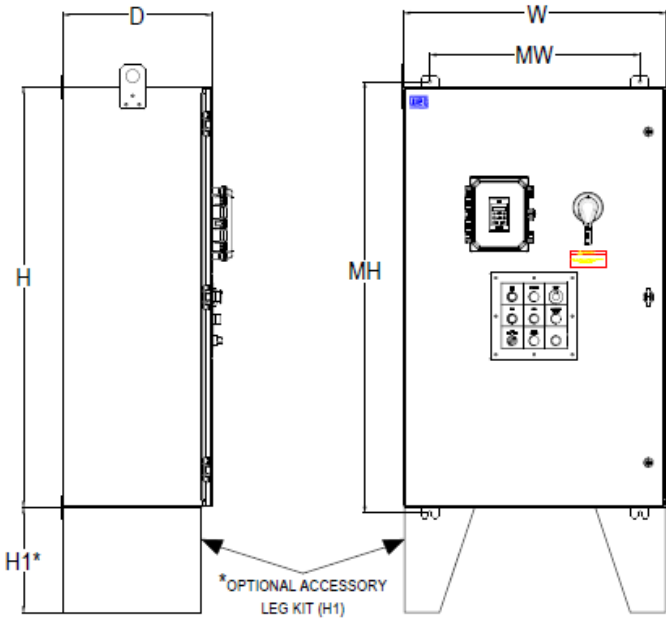

Enclosure Frame: 4

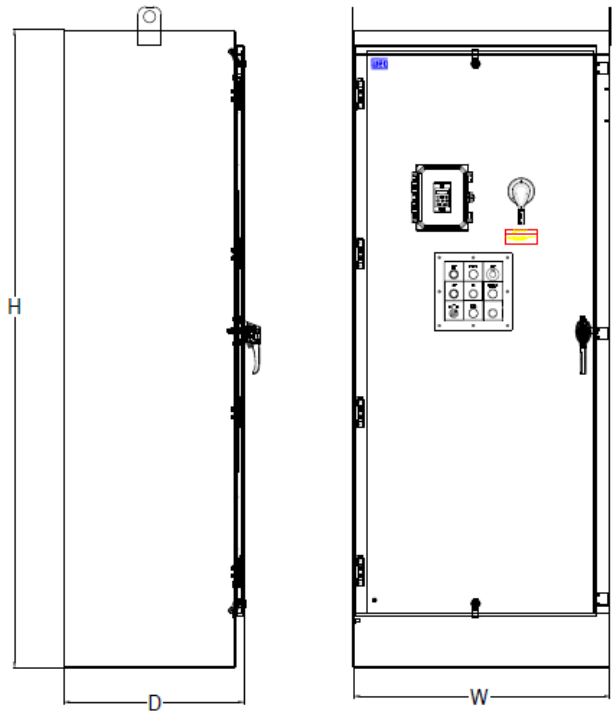

ENCL. FRAME	W (in)	D (in)	H (in)	H1* (in)	MH (in)	MW (in)	MOUNTING
1	20	16	32	6/12	33.25	14	Wall (Floor with optional 6" or 12" tall floor kit)
2	24	18	37	6/12	38.25	18	
3	30	16	48	6/12	49.25	24	
4	33	22	82	-	-	-	Free Standing

* Optional Leg Kit Accessory 6" or 12" Tall



OPTIONAL ACCESSORIES - LEG KITS

6" Tall Leg Kit

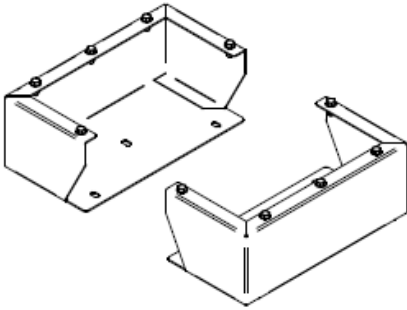

12" Tall Leg Kit

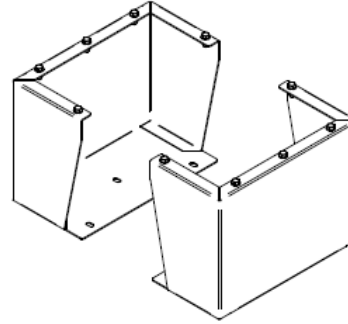

CONVERSION FROM 3/460VAC TO 3/230VAC OR 3/208VAC SUPPLY VOLTAGE:

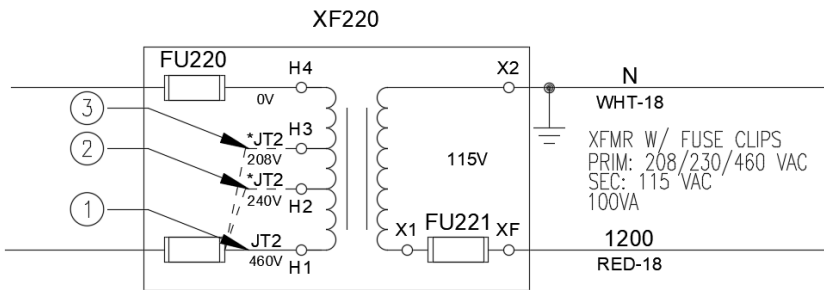

NOTE: CONTROL POWER TRANSFORMER IS CONFIGURED FROM FACTORY AS 460-480V INPUT SUPPLY VOLTAGE.

CUSTOMER MUST RECONFIGURE FOR 208V OR 230-240V INPUT SUPPLY VOLTAGE BY RETERMINATING XF220 JUMPER 'JT2' ONTO COORESPONDING PIN.

SEE TRANSFORMER CONFIGURATION TABLE

TRANSFORMER CONFIGURATION TABLE			200VA FUSE SIZE	
XF220 INPUT SUPPLY VOLTAGE	JT2* WIRING PIN	200VA FUSE SIZE		
		*FU220 (CC)	**FU221 (MIDGET)	
① 460 VAC (DEFAULT)	H1			
② 230 VAC	H2	2.0 A	2.75 A	
③ 208 VAC	H3			

APPLICATIONS

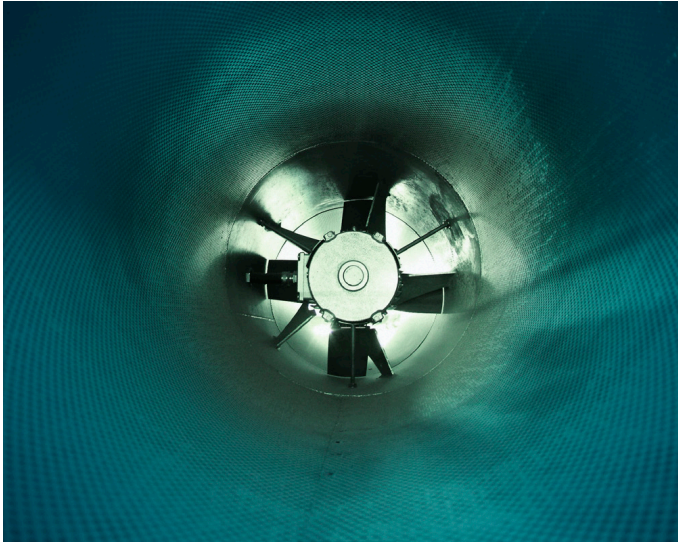

Cement and Mining



- Dosing pumps
- Sifters / vibrating tables
- Dynamic graders
- Conveyor belts

Chemical and Petrochemical



- Fans / exhaust fans
- Centrifugal pumps
- Dosing pumps
- Centrifuges
- Stirrers / mixers
- Compressors
- Soap extruders

Wood



- Veneer machines
- Polishing machines
- Cutting machines
- Wood chippers
- Saw and planes

Plastic and Rubber



- Extruders
- Blowers
- Mixers
- Calenders
- Granulators

Water & Wastewater



- Centrifugal-pumps
- Suppression systems

Food & Beverage



- Continuous centrifuges
- Roller tables
- Conveyor belts
- Bottling lines

Ceramic



- Fans / exhaust fans
- Continuous dryers / ovens
- Ball mills
- Roller tables
- Conveyor belts

Steel and Metallurgy



- Fans / exhaust fans
- Conveyors
- Drilling machines / grinders
- Pumps

Glass



- Fans / exhaust fans
- Continuous dryers / ovens
- Roller tables

Textile



- Stirrers / mixers
- Dryers / washing machines

Light Duty: Agitator, Bow Thruster - Zero Pitch, Compressor - Rotary Vane, Compressor - Scroll, Feeder - screw, Lathe machines, Molding Machine, Roller table.

Normal Duty: Ball mill, Bow Thruster - Loaded, Compressor - Reciprocating, Compressor - Rotary Screw, Conveyor - unloaded, Grinder, Hammer mill, Mixer, Pelletizers, Pump, Pump Jack, Rolling mill, Saw, Screen vibrating, Tumblers, Fan - Low Inertia, Sifters/vibrating tables, Dynamic Graders, Extruder, Calender, Blower, Granulators, Continuous Dryer and Oven, Suppression systems, Bottling lines.

Heavy Duty: Centrifuge, Crusher, Conveyor - loaded, Fan - High Inertia, Shredder, Wood chipper, Press, flywheel, Compressor - Centrifugal.

For WEG's worldwide
operations visit our website



www.weg.net - 1-800-ASK-4WEG



WEG Electric Corp.
6655 Sugarloaf Parkway
Duluth, GA 30097
Phone: 1-800-ASK-4WEG
www.weg.net

Please contact your authorized distributor: