

Three phase induction motors cooled by water jacket

W line - Squirrel cage rotor
Horizontal and Vertical

Installation, Operation and Maintenance Manual





Installation, Operation and Maintenance Manual

Model: WGM

Document Number: 11239449

Language: English

Revision: 13

June 2024

Dear Customer,

Thank you for purchasing a WEG motor. Our products are developed with the highest standards of quality and efficiency which ensures outstanding performance.

Since electric motors play a major role in the comfort and well-being of humankind, it must be identified and treated as a driving machine with characteristics that involve specific care, such as proper storage, installation and maintenance

All efforts have been made to ensure that the information contained in this manual is faithful to the configurations and applications of the motor.

Therefore, we recommend that you read this manual carefully before proceeding with the installation, operation or maintenance of the motor in order to ensure safe and reliable operation of your equipment and facility. If you need any further information, please contact WEG.

Always keep this manual close to the motor, so that it can be consulted whenever necessary.



ATTENTION

1. It is imperative to follow the procedures contained in this manual for the warranty to be valid;
2. The motor installation, operation and maintenance procedures must be performed only by qualified personnel.



NOTES

1. The total or partial reproduction of information supplied in this manual is authorized, provided that reference is made to its source. If this manual is lost, an electronic PDF file is available at www.weg.net or another printed copy may be requested.

WEG EQUIPAMENTOS ELÉTRICOS S.A.

TABLE OF CONTENTS

1	INTRODUCTION	11
1.1	SAFETY WARNINGS IN THE MANUAL.....	11
2	GENERAL INSTRUCTIONS	12
2.1	QUALIFIED PERSONNEL	12
2.2	SAFETY INSTRUCTIONS	12
2.3	STANDARDS	12
2.4	ENVIRONMENTAL CONDITIONS.....	12
2.5	OPERATING CONDITIONS.....	13
2.6	VOLTAGE AND FREQUENCY	13
3	RECEIVING, HANDLING AND STORAGE.....	14
3.1	RECEIVING.....	14
3.2	HANDLING	14
3.2.1	Vertical motor positioning.....	15
3.3	STORAGE	15
3.3.1	Outdoor storage.....	15
3.3.2	Extended storage.....	15
3.3.2.1	Storage location	15
3.3.2.1.1	Indoor storage.....	16
3.3.2.1.2	Outdoor storage	16
3.3.2.2	Separate parts.....	16
3.3.3	Preservation during the storage.....	16
3.3.3.1	Cooling system.....	16
3.3.3.2	Space heater.....	16
3.3.3.3	Insulation resistance.....	16
3.3.3.4	Exposed machined surfaces	16
3.3.3.5	Sealing	16
3.3.3.6	Bearings.....	17
3.3.3.6.1	Grease-lubricated rolling bearing.....	17
3.3.3.7	Terminal boxes.....	17
3.3.3.8	Inspections and records during storage	17
3.3.3.9	Predictive / preventive maintenance.....	17
3.3.3.10	Maintenance plan during storage	18
3.3.4	Preparation for commissioning	19
3.3.4.1	Cleaning.....	19
3.3.4.2	Bearing lubrication.....	19
3.3.4.3	Insulation resistance verification	19
3.3.4.4	Cooling system.....	19
3.3.4.5	Others	19
4	INSTALLATION	20
4.1	INSTALLATION SITE.....	20
4.2	SHAFT LOCK.....	20
4.3	ROTATION DIRECTION	20
4.4	INSULATION RESISTANCE.....	20
4.4.1	Safety Instructions	20
4.4.2	General considerations	20
4.4.3	Measurement on the stator windings	20
4.4.4	Additional Information	21
4.4.5	Conversion of the measured values	21
4.4.6	Polarization Index (P.I).....	21
4.4.7	Recommended Minimum Values	21
4.5	PROTECTIONS	21
4.5.1	Thermal protections	21
4.5.1.1	Temperature limits for the windings.....	22
4.5.1.2	Alarm and trip temperatures	22
4.5.1.3	Installation of temperature sensors	22
4.5.1.4	Temperature and ohmic resistance of the PT100 thermoresistance	23
4.5.1.5	Space heater.....	23
4.5.2	Water leak sensor.....	23
4.5.3	Water temperature sensor	23
4.6	COOLING.....	24
4.6.1	Cooling system characteristics	24
4.6.2	Cooling water characteristics	24

4.6.2.1	Cooling water temperature	24
4.6.3	Protective devices	24
4.7	ELECTRICAL ASPECTS	25
4.7.1	Electrical connections	25
4.7.1.1	Main electrical connections	25
4.7.1.2	Grounding	25
4.7.2	Connection diagrams	26
4.7.2.1	Connection diagrams according to IEC60034-8	26
4.7.2.1.1	Stator connection diagrams	26
4.7.2.2	Connection diagrams according to NEMA MG1	27
4.7.2.2.1	Stator connection diagrams	27
4.7.2.3	Rotation direction	27
4.7.2.4	Accessory connection diagrams	27
4.8	MECHANICAL ASPECTS	28
4.8.1	Base	28
4.8.2	Base loads	28
4.8.3	Base types	28
4.8.3.1	Concrete base	28
4.8.3.2	Sliding base	28
4.8.3.3	Metal base	29
4.8.3.4	Anchor bolts	29
4.8.4	Natural frequency of the base	29
4.8.5	Leveling	29
4.8.6	Alignment	29
4.8.7	Doweling	30
4.8.8	Couplings	30
4.8.8.1	Direct coupling	31
4.8.8.2	Gear coupling	31
4.8.8.3	Belt drive	31
5	STARTING	32
5.1	DIRECT ON-LINE STARTING	32
5.2	DIRECT ONLINE STARTING FREQUENCY	32
5.3	LOCKED ROTOR CURRENT	32
5.4	STARTING WITH REDUCED CURRENT	32
6	COMMISSIONING	33
6.1	PRELIMINARY INSPECTION	33
6.2	FIRST STARTING	33
6.3	OPERATION	33
6.3.1	General	34
6.3.2	Temperatures	34
6.3.3	Bearings	34
6.3.4	Cooling system	34
6.3.5	Vibration	34
6.3.6	Shutdown	34
7	MAINTENANCE	35
7.1	GENERAL	35
7.2	GENERAL CLEANING	35
7.3	WINDING MAINTENANCE	35
7.3.1	Winding inspection	35
7.3.2	Winding cleaning	35
7.3.3	Inspections	35
7.3.4	Reimpregnation	35
7.3.5	Insulation Resistance	36
7.4	COOLING SYSTEM MAINTENANCE	36
7.5	VIBRATION	36
7.6	MOTOR OUT OF OPERATION	36
7.7	SHAFT GROUNDING DEVICE	36
7.8	ENCODER MAINTENANCE	36
7.9	BEARING MAINTENANCE	37
7.9.1	Grease-lubricated rolling bearings	37
7.9.1.1	Instructions for lubrication	37
7.9.1.2	Procedures for rolling bearing relubrication	37
7.9.1.3	Rolling bearing relubrication with drawer device for grease removal	37
7.9.1.4	Type and amount of grease	37
7.9.1.5	Alternative greases	38

7.9.1.6	Procedure for changing the grease	38
7.9.1.7	Low temperature greases	38
7.9.1.8	Grease compatibility	38
7.9.1.9	Disassembly – horizontal bearings	39
7.9.1.10	Disassembly – vertical bearings	40
7.9.1.10.1	Before disassembling	40
7.9.1.10.2	Lower bearing disassembly	40
7.9.1.10.3	Upper bearing disassembly	40
7.9.1.11	Bearing assembly	41
7.9.2	Rolling bearing replacement	41
7.9.3	Bearing protection	41
7.9.3.1	Protection settings	41
7.9.3.2	Disassembly/assembly of the sleeve bearing temperature sensors	41
8	MOTOR DISASSEMBLY AND ASSEMBLY	42
8.1	HORIZONTAL MOTORS	42
8.1.1	Disassembly	42
8.1.2	Assembly	42
8.2	VERTICAL MOTORS	43
8.2.1	Disassembly	43
8.2.2	Assembly	43
8.3	AIR-GAP MEASUREMENT	44
8.4	TIGHTENING TORQUE	44
8.5	SPARE PARTS	44
9	MAINTENANCE PLAN	45
10	ABNORMALITIES, CAUSES AND SOLUTIONS	46
11	DECLARATION OF CONFORMITY	48
12	ENVIRONMENTAL INFORMATION	49
12.1	PACKAGE	49
12.2	PRODUCT	49
12.3	HAZARDOUS WASTE	49
13	SERVICE NETWORK	49
14	WARRANTY TERM	50

1 INTRODUCTION

This manual contains information regarding low and high-voltage, three-phase induction motors.

Motors with special features can be supplied with specific documents (drawings, connection diagram, characteristic curves etc.). Those documents, together with this manual, must be thoroughly evaluated before proceeding with the installation, operation or maintenance of the motor.

In order to use a frequency inverter, it is mandatory to follow the instructions contained in the specific technical documentation of the motor and in the manual of the frequency inverter.

If any additional explanation about motors with major special features is necessary, consult WEG. All procedures and standards contained in this manual must be observed in order to ensure proper operation of the motor and the safety of the personnel involved in its operation. Following these procedures is also important to ensure the validity of the motor warranty. Thus, we recommend the careful reading of this manual before the installation and operation of the motor. If any further information is still necessary, consult WEG.

1.1 SAFETY WARNINGS IN THE MANUAL

In this manual, the following safety warnings are used:



DANGER

Failure to observe the procedures recommend in this warning may result in death, serious injuries and extensive equipment damage.



ATTENTION

Failure to observe the procedures recommend in this warning may result in equipment damage.



NOTE

This provides important information for correct understanding and proper operation of the product.

2 GENERAL INSTRUCTIONS

All the personnel involved with the assembly, operation or maintenance of electrical installations must be permanently informed and updated on the standards and safety instructions that guide the job and are advised to strictly comply with them. Before beginning any job, the person in charge must make sure that all points have been duly observed and warn the respective personnel about the danger inherent to the task to be performed.

Improper application, inadequate handling or maintenance of the motor, may cause serious injuries and/or material damages.

Therefore, it is highly recommended that these services be always performed by qualified personnel.

2.1 QUALIFIED PERSONNEL

The term qualified personnel means those who, because of their training, experience, education level, and knowledge of the applicable standards, specifications, accident prevention, safety standards and operating conditions, have been authorized by the persons in charge to execute the necessary tasks, and who are able to recognize and avoid any possible danger. Such qualified personnel must also know and be able to provide first aid procedures if necessary. The entire start-up, maintenance and repair tasks must only be performed by qualified personnel.

2.2 SAFETY INSTRUCTIONS



DANGER

During normal operation of this equipment, a hazard associated with energized or rotating components with high voltage or elevated temperatures exists. Thus, the operation with open terminal boxes, unprotected couplings, improper handling, or failure to comply with the operating standards, may cause severe personal injuries and material damages.



ATTENTION

When devices and equipment are used outside the industrial environment, the user must ensure the safety of the equipment by adopting proper protection and safety measures during installation (for example, keep people away, avoid contact of children, etc.).

Those responsible for the safety of the installation must ensure that:

- Only qualified personnel install and operate the equipment;
- They have this manual and all other documents supplied with the motor at hand, as well as that they perform the tasks in strict compliance with the service instructions, relevant standards and specific product documentation;



ATTENTION

Failure to comply with installation and safety standards may void the product warranty. Firefighting equipment and first aid notices must be available in visible and easily accessible locations at the work site.

Qualified personnel must also observe:

- All the technical data regarding the allowed applications (operating conditions, connections and installation environment), included in the catalog, in the purchase order documents, in the operating instructions, in manuals and all other documentation;
- The specific regulations and conditions for the local installation;
- The use of suitable tools and equipment for handling and transportation;
- That the protective devices of the individual components are removed shortly before installation. Individual parts must be stored in vibration-free environments, avoiding falls and ensuring their protection against aggressive agents and/or that they do not jeopardize people.

2.3 STANDARDS

The motors are specified, designed, manufactured and tested according to the standards described in Table 2.1. The applicable standards are specified in the commercial contract, which may indicate other national or international standards, depending on the application or installation location.

Table 2.1: Applicable standards

	IEC / NBR	NEMA
Specification	IEC60034-1 / NBR 17094	MG1-1,10,20
Dimensions	IEC60072 / NBR 15623	MG1-4,11
Tests	IEC60034-2 / NBR 5383	MG1-12
Levels of protection	IEC60034-5 / NBR IEC 60034-5	MG1-5
Cooling	IEC60034-6 / NBR IEC 60034-6	MG1-6
Mounting	IEC60034-7 / NBR IEC 60034-7	MG1-4
Noise	IEC60034-9 / NBR IEC 60034-9	MG1-9
Mechanical Vibration	IEC60034-14 / NBR IEC 60034-14	MG1-7
Terminal marking	IEC60034-8 / NBR 15367	MG1-2
Mechanical Tolerances	ISO286 / NBR6158	MG1-4
Balancing	ISO1940	MG1-7

2.4 ENVIRONMENTAL CONDITIONS

The motor was designed according to the specific environmental conditions (temperature and altitude) of your application, and are described on the nameplate and in the datasheet of the motor.



ATTENTION

For the use of water-cooled motors in ambient temperatures below +5°C, antifreeze additives must be added to the water.

2.5 OPERATING CONDITIONS

In order for the product warranty to be valid, the motor must be operated according to nominal data indicated on its nameplate, observing all applicable standards and information contained in this manual.

2.6 VOLTAGE AND FREQUENCY

It is very important to ensure a proper power supply for the motor. The conductors and the entire protection system must ensure the quality of the power supply at the motor terminals within the limits, in accordance with the IEC60034-1 standard:

- Voltage: may vary within a range of $\pm 10\%$ of the rated value;
- Frequency: may vary within a range of -5% to $+3\%$ of the rated value.

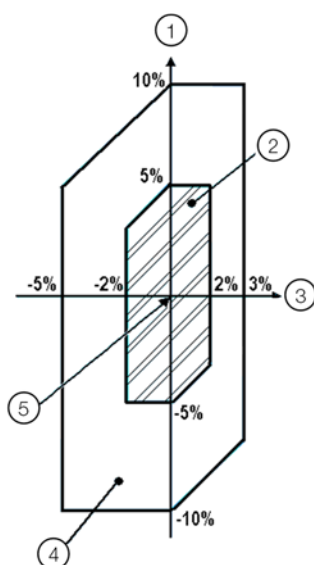

Figure 2.1: Voltage and frequency variation limits

Figure 2.1 legend:

1. Voltage
2. Zone A
3. Frequency
4. Zone B (outside zone A)
5. Voltage with rated characteristics

The motor must be able to perform its main function continuously in Zone A, but it may not fully meet its performance characteristics at rated voltage and frequency (refer to the point with rated characteristics in Figure 2.1), when it may present some deviations. The temperature rises may be above those at rated voltage and frequency.

The motor must be able to perform its main function in Zone B, but regarding the performance characteristics at rated voltage and frequency, it may present deviations greater than those of Zone A. The temperature rises may be higher than those observed at rated voltage and frequency, and they will most likely be higher than those in Zone A.

Prolonged operation in the periphery of Zone B is not recommended.

3 RECEIVING, HANDLING AND STORAGE

3.1 RECEIVING

All motors were tested and are in perfect operating conditions. The machined surfaces are protected against corrosion. The package must be inspected upon receipt for occasional damages during transportation.

 **ATTENTION**
Any damage must be photographed, documented and reported immediately to the carrier, the insurer and WEG. The non-communication of this damage will void the warranty.

 **ATTENTION**
Parts supplied in additional packages must be checked upon receipt.

- When lifting the package (or container), the proper hoisting points, the weight indicated on the package or on the nameplate and the operating capacity and conditions of the hoisting equipment must be observed;
- Motors packed in wooden crates must always be lifted by their own lifting lugs or by a proper forklift; they must never be lifted by the package;
- The package can never be overturned. Place it on the floor carefully (without impact) in order to avoid damage to the bearing;
- Do not remove the grease for protection against corrosion from the shaft end, or the closing plugs present in the terminal box holes. These protections must remain in place until the moment of the final assembly.
- A complete visual inspection of the motor must be carried out after removing the package;
- The shaft locking system must be removed just before the installation and stored to be used in future transportation of the motor.

3.2 HANDLING

Horizontal motors must be handled as shown in Figure 3.1;

- The lifting chains or cables must have a maximum angle of 30° from the vertical;
- In order to lift the motor, use only the lifting lugs provided for that purpose.

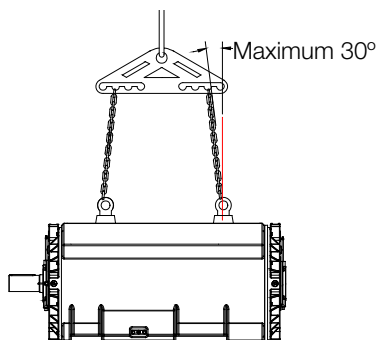

Figure 3.1: Horizontal motor handling

Vertical motors must be handled as shown in Figure 3.2; Always use the upper lifting lugs of the motor for handling it in the vertical position, making sure the chains and cables are also in the vertical position, avoiding too much stress on the lifting lugs.

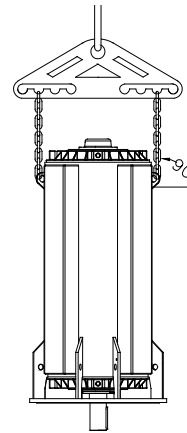

Figure 3.2: Vertical motor handling



NOTES

- Observe the indicated weight. Do not lift the motor causing jolts or put it down abruptly on the floor, because this may cause damage to the bearings;
- In order to lift the motor, use only the lifting lugs provided for that purpose. If necessary, use a crossbeam to protect parts of the motor.
- The lifting lugs on the heat exchanger, end shields, bearings, radiator, terminal box, etc. are designed to handle these components only separately;
- Never use the shaft to lift the motor;
- The frame lifting lugs are intended to lift only the motor. Never use them to lift the motor-driven machine set.



ATTENTION

- In order to move or transport the motor, the shaft must be locked with the locking device supplied with the motor.
- Lifting equipment and devices must be able to withstand the motor weight.

3.2.1 Vertical motor positioning

Vertical motors are supplied with lifting lugs at the drive end DE and non-drive end NDE. Some motors are transported in the horizontal position and need to be moved to the original position. The following procedure shows how to move motors from the horizontal position to the vertical position and vice versa.

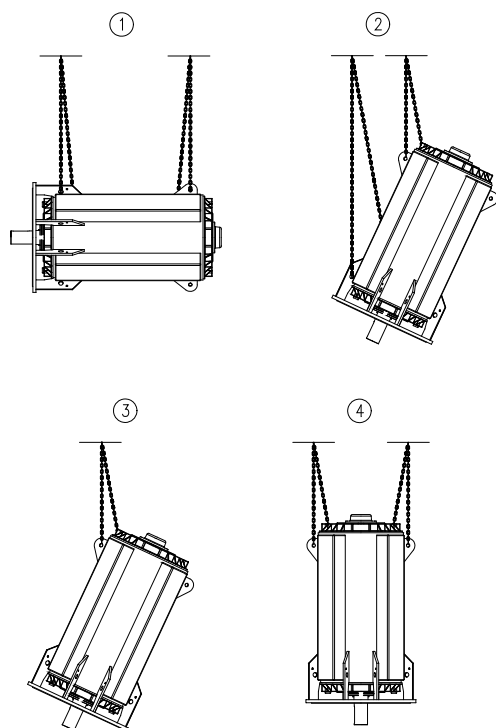

Figure 3.3: Vertical motor positioning

1. Lift the motor with the side lifting lugs using two hoists;
2. Lower the motor drive end (DE) and lift the non-drive end (NDE) at the same time until balance is reached;
3. Loosen the DE cables and turn the motor 180° in order to enable the connection of these cables to the other lifting lugs of the NDE;
4. Connect the loose cables to the NDE lifting lugs and lift them until the motor reaches the vertical position.



ATTENTION

Failure to comply with these recommendations may cause damage to the equipment, personal injuries or both.

3.3 STORAGE

If the Motor is not installed immediately after reception, it must remain inside the package and stored in a location protected against moisture, vapors, sudden changes in temperature, rodents and insects.

The motor must be stored in vibration-free locations in order to avoid bearing damage.



ATTENTION

Space heaters must remain powered during storage in order to avoid moisture condensation inside the motor. Any damage to the paint or corrosion protection of the machined parts must be repaired.

3.3.1 Outdoor storage

The motor must be stored in a dry location, free of flooding and vibrations.

Repair any damages on the package before storing the motor, which is needed to ensure proper storage conditions.

Place the motor on platforms or foundations that ensure protection against humidity from the ground and prevent it from sinking into the soil. Free air circulation underneath the motor must be assured.

The cover used to protect the motor against the bad weather must not be in contact with its surfaces. In order to ensure free air circulation between the motor and such covers, place wooden blocks as spacers.

3.3.2 Extended storage

When the motor is stored for a long period of time (two months or more) before start-up, it is exposed to external agents, such as temperature variations, moisture, aggressive agents, etc.

The empty spaces inside the motor – such as rolling bearings, terminal boxes, and windings – are exposed to humidity, which can cause condensation, and, depending on the degree of air contamination, aggressive substances may also penetrate these empty spaces.

Consequently, after long periods of storage, the winding insulation resistance may drop below the acceptable values, internal components, such as rolling bearings, may oxidize, and the lubricant power of the lubricant agent in the bearings may be adversely affected.

All of these influences increase the risk of damages before starting the motor.



ATTENTION

To assure that the motor warranty be valid, it is necessary to make sure that all preventive measures described in this manual, such as constructive aspects, maintenance, packaging, storage, and periodical inspections, are followed and recorded.

The extended storage instructions are valid for motors that remain stored for long periods (two months or more) before start-up or motors already installed that are in a prolonged stoppage, considering the same period.



ATTENTION

For extended periods of stoppage or storage, the water inside of the frame must be drained.

3.3.2.1 Storage location

In order to ensure the best storage conditions for the motor during long periods, the chosen location must strictly meet the criteria described in sections 1.1.1.1.1 and 3.3.2.1.2.

3.3.2.1.1 Indoor storage

In order to ensure better storage conditions for the motor, the storage site must comply strictly with the criteria described below:

- The storage site must be closed, covered, dry, free of air contaminants (moisture, vapor, dust, particles and aggressive fumes) and free of flooding;
- The site should be protected against sudden temperature variations, humidity, rodents and insects;
- Vibration-free location, to avoid damaging to the motor bearings;
- The floor must be of leveled concrete with resistant structure to support the motor weight;
- Must have system to fire detection and extinguishing;
- Be provided with electricity for supplying the space heaters with power failure detection system;
- Exclusive site to store electrical machines (do not mix with other equipment and/or products that could prejudice the correct motor storage);
- Site with facilities of cargo handling services, suitable to allow the motor handling and removal;
- There must be no gas present, such as chlorine, sulfur dioxide or acids;
- The site must have ventilation system with air filter;
- Ambient temperature between 5°C and 50°C, and should not present sudden temperature variation;
- Relative air humidity <50%;
- Must have prevention against dirt and dust deposition;
- The motor should be stored on a suitable metal base that prevents the absorption of moisture from the floor.

If any of these requirements is not met in the storage site, WEG suggests that additional protections be added to the motor package during the storage period, as follows:

- A closed wooden crate or the like with an electrical installation that allows the energization of the space heaters;
- If there is a risk of infestation and fungus formation, the package must be protected in the storage place by spraying it or painting it with appropriate chemicals;
- The package preparation must be prepared carefully by an experienced person.

3.3.2.1.2 Outdoor storage



ATTENTION
Outdoor storage of the motor is not recommended.

In case outdoor storage is unavoidable, the motor must be packed in specific packaging for such conditions, as follows:

- For outdoor storage (exposed to the weather), besides the packaging recommended for indoor storage, the package must be covered with protection against dust, moisture and other odd materials, using resistant canvas or plastic.
- The package must be placed on platforms or foundations that ensure protection against dirt and moisture and prevent it from sinking into the soil;
- After the package is covered, a shelter must be erected to protect it against direct rain, snow and excessive sun heat.



ATTENTION
In case the motor remains stored for long periods (two months or more), it is recommended to inspect it regularly as specified in the section Maintenance plan during storage of this manual.

3.3.2.2 Separate parts

- If parts are supplied separately (terminal boxes, heat exchanger, end shields, etc.), these parts must be mounted on motor to store it;
- Spare parts must be stored in an adequate place, as specified in sections 3.3.2.1.1 and 3.3.2.1.2 of this manual.
- The relative humidity inside the package must not exceed 50%.
- Rolling bearings must not be subject to shocks, falls or storage with vibration or humidity, which can cause marks on the internal tracks or on the balls, reducing their useful life.

3.3.3 Preservation during the storage

3.3.3.1 Cooling system

After the motor operation, to preserve the cooling system during long-term storage, the following criteria must be strictly observed:

- Blow hot air in one of the holes for 15 to 20 minutes, to eliminate the moisture from inside the frame inner channels;
- After drying, the water inlet and outlet should be closed.

3.3.3.2 Space heater

Space heaters must remain powered during storage to avoid moisture condensation inside the motor and ensure that the winding insulation resistance remains within acceptable levels.

The space heaters drive circuit must be unique and the voltage and current of this circuit must be measured and recorded monthly.

It is recommended that a signal be installed near the motor to indicate that the space heaters are energized.

3.3.3.3 Insulation resistance

During the storage period, the insulation resistance of the motor windings must be measured and recorded every two months, and before the motor installation or eventually if there is any change in the preservation process (E.g. prolonged lack of electricity).

The measurement procedures and the criteria for acceptance of the results shall be according to IEEE-43 Standard.

Any insulation resistance reduction must be investigated.

3.3.3.4 Exposed machined surfaces

All exposed machined surfaces (e.g., shaft end and flanges) are protected at the factory with a temporary protective agent (rust inhibitor).

This protection coating must be reapplied at least every six months or when removed and/or damaged.

Recommended Product: Protective agent Anticorit BW
Supplier: Fuchs

3.3.3.5 Sealing

The rubber seals, gaskets, plugs and cable glands of the motor shall be inspected annually and replaced, if necessary.

3.3.3.6 Bearings

3.3.3.6.1 Grease-lubricated rolling bearing

- The rolling bearings are lubricated at the factory for the motor tests.



ATTENTION

In order to keep the bearings in good condition during the storage period, **the shaft locking device must be removed every two months, and the motor rotor must be rotated at least 10 complete turns at 30 rpm** to circulate the grease and preserve the internal parts of the bearings.

- Before putting the motor into operation, the rolling bearings must be lubricated;
- If the motor remains stored for a period exceeding two years, the rolling bearings must be disassembled, washed, inspected and relubricated.

3.3.3.7 Terminal boxes

When the insulation resistance of the motor windings is measured, the main terminal box and the other terminal boxes must also be inspected, observing the following aspects:

- The inside must be dry, clean and free of any dust accumulation;
- The contact elements cannot present corrosion;
- The seals must be in proper condition;
- The cable inlets must be correctly sealed.



ATTENTION

If any of these items are not in proper condition, proceeds the adequate maintenance and, if necessary, replace damaged parts.

3.3.3.8 Inspections and records during storage

The stored motor must be inspected periodically and inspection records must be filed.

The following items must be inspected:

1. Check the motor for physical damages and repair it, if necessary;
2. Inspection of the cleanliness conditions;
3. Check for signs of water condensation inside the motor;
4. Check of the protective coating conditions of the exposed machined parts;
5. Check the paint conditions, and repair if necessary;
6. Check for aggressive agents signs;
7. Check the operation of the space heaters;
8. Measure and record the ambient temperature and relative humidity around the motor;
9. Measure and record the temperature, insulation resistance and polarization index of the stator winding;
10. Make sure that the storage location complies with the criteria described in section 3.3.2.1.

3.3.3.9 Predictive / preventive maintenance

WEG recommends that, every 3 years of storage, the stored motor be sent to a WEG Authorized Repair Shop or to WEG own factory, in order to perform a complete predictive maintenance.

The complete predictive maintenance procedure comprises disassembling the complete motor for inspection and, after assembly, performing a routine test in the laboratory.

3.3.3.10 Maintenance plan during storage

During the storage period, the motor maintenance must be performed and recorded according to the plan described in Table 3.1.

Table 3.1: Storage plan

	Monthly	2 months	6 months	2 years	Before start-up	Notes
STORAGE LOCATION						
Inspect the cleanliness conditions		X			X	
Inspect the humidity and temperature conditions		X				
Inspect for insect infestation signs		X				
PACKAGE						
Inspect for damages			X			
Check the internal relative humidity		X				
Replace the desiccant in the package (if any)			X			Whenever necessary.
SPACE HEATER						
Check the operating conditions	X					
Measure the circuit voltage and frequency	X					
Check the function of the signal system (if any)			X			
WHOLE MOTOR						
Perform external cleaning			X		X	
Check the painting conditions			X			
Check the rust inhibitor on the exposed machined parts			X			
Reapply the rust inhibitor			X			
Drain the water condensed inside the motor			X			
Inspect the rubber seals and gaskets	X					
Complete predictive maintenance						According to section 3.3.3.9
WINDINGS						
Measure the winding temperature		X			X	
Measure the insulation resistance		X			X	
Measure the polarization index		X			X	
TERMINAL BOX AND GROUNDING TERMINALS						
Clean the interior of the terminal boxes				X	X	
Inspect the seals and gaskets				X	X	
BEARINGS						
Rotate the shaft		X				
Relubricate the bearing					X	
Disassemble and clean the bearing						If the storage period exceeds 2 years.

3.3.4 Preparation for commissioning

3.3.4.1 Cleaning

- The internal and external parts of the motor must be free of oil, water, dust and dirt.
- Remove the rust inhibitor from the exposed surfaces with a cloth damped in a petroleum-based solvent;
- Make sure that the bearings and cavities used for lubrication are free of dirt and that the cavity plugs are correctly sealed and tightened. Oxidation and marks on the bearing seats and on the shaft must be carefully removed.

3.3.4.2 Bearing lubrication

Use the lubricant specified for bearing lubrication. Information on the bearings and lubricants are indicated on the bearing nameplates, and the lubrication must be done as described in section 1.1 of this manual, always considering the type of bearing.

3.3.4.3 Insulation resistance verification

Before putting the motor into operation, the insulation resistance must be measured according to section 3.3.3.3 of this manual.

3.3.4.4 Cooling system

If the motor remains out of operation for a long period (two months or more), it must be ensured that water circulates freely through the motor cooling system before putting it back into operation.

3.3.4.5 Others

Follow the other procedures described in section 6 of this manual before putting the motor into operation.

4 INSTALLATION

4.1 INSTALLATION SITE

Electric motors must be installed in easily accessible places, allowing periodic inspections, on-site maintenance and, if necessary, removal for external services.

The following environmental conditions must be ensured:

- Clean and well-ventilated location;
- The installation of other equipment or walls must not block or hinder the motor ventilation;
- The area around and above the motor must be sufficient for maintenance or handling;
- The environment must be in accordance with the motor protection degree.

4.2 SHAFT LOCK

The motor leaves the factory with a lock on the shaft to prevent damages to the bearings during transportation. This lock must be removed prior to motor installation.



ATTENTION

The shaft-locking device must be installed whenever the motor is removed from its base (uncoupled) in order to prevent damages to the bearings during transportation.

The shaft end is protected at the factory with a temporary protective agent (rust inhibitor). During the motor installation, it is necessary to remove this product from the grounding brush (if any) contact track on the shaft.

4.3 ROTATION DIRECTION

The motor rotation direction is indicated by a plate affixed to the frame on the drive end and in the motor specific documentation.



ATTENTION

Motors supplied with a single rotation direction must not operate in the opposite direction. In order to operate the motor in the direction opposite to the specified, consult WEG.

4.4 INSULATION RESISTANCE

4.4.1 Safety Instructions



DANGER

In order to measure the insulation resistance, the motor must be turned off and stopped.

The winding being tested must be connected to the frame and grounded until all residual electrostatic charges are removed. Capacitors (if any) must also be grounded before disconnecting and separating the terminals to measure the insulation resistance. Failure to comply with these procedures may result in personal injury.

4.4.2 General considerations

When the motor is not immediately put into operation, it must be protected against moisture, high temperatures, and dirt, thus avoiding impacts on the insulation resistance.

The winding insulation resistance must be measured before putting the motor into operation.

If the environment is too humid, the insulation resistance must be measured periodically during storage. It is difficult to establish fixed rules for the actual value of winding insulation resistance, as it varies according to the environmental conditions (temperature, humidity), machine cleanliness conditions (dust, oil, grease, dirt) and quality and condition of the insulating material used. The evaluation of the periodical follow-up records is useful to conclude whether the motor is able to operate.

4.4.3 Measurement on the stator windings

The insulation resistance must be measured with a megohmmeter. The testing voltage for the motor windings must be in accordance with Table 4.1 and IEEE43 standard.

Table 4.1: Voltage for the winding Insulation resistance test

Winding rated voltage (V)	Insulation resistance test - continuous voltage (V)
< 1000	500
1000 - 2500	500 - 1000
2501 - 5000	1000 - 2500
5001 - 12000	2500 - 5000
> 12000	5000 - 10000

Before measuring the stator winding insulation resistance:

- Disconnect all connections to the stator terminals;
- Disconnect and insulate all CTs and PTs (if any);
- Ground the motor frame;
- Measure the winding temperature;
- Ground all temperature sensors;
- Check the humidity.

The insulation resistance measurement of the stator windings must be done in the main terminal box.

The megohmmeter must be connected between the motor frame and the winding.

The frame must be grounded and the three phases of the stator winding must remain connected to the neutral point, according to Figure 4.1.

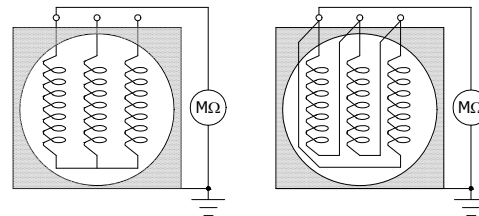

Figure 4.1: Megohmmeter connection

Whenever possible, each phase must be isolated and tested separately. The separate test allows the comparison between the phases. When a phase is tested, the other two phases must be grounded to the same ground of the frame, according to Figure 4.2.

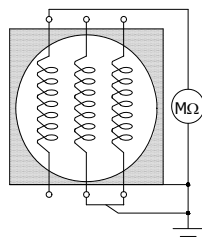

Figure 4.2: Connection of the megohmmeter to separate phases

If the total winding measurement presents a value below the recommended, the neutral connections must be opened and the insulation resistance of each phase must be measured separately.



ATTENTION

Much higher values may be frequently obtained from motors in operation for long periods of time. Comparison with values obtained in previous tests on the same motor - under similar load, temperature and humidity conditions - may be an excellent parameter to evaluate the winding insulation conditions, instead of using the value obtained in a single test as the basis. Significant or sudden reductions are considered suspicious.

4.4.4 Additional Information



ATTENTION

After measuring the insulation resistance, ground the tested winding in order to discharge it. The testing voltage to measure the insulation resistance of the space heater must be 500 Vdc and for the other accessories, 100 Vdc. It is not recommended to measure the insulation resistance of thermal protectors.

4.4.5 Conversion of the measured values

The insulation resistance measured on the windings shall be converted to 40 ° C using the correction factor provided in Figure 4.3 (IEEE43 standard) and applying the following formula:

$$R_c = K_t \cdot R_t$$

Where:

R40 = referred insulation resistance at 40 ° C

Kt = Insulation resistance correction factor as a function of temperature, as shown in Figure 4.3,

Rt = measured insulation resistance.

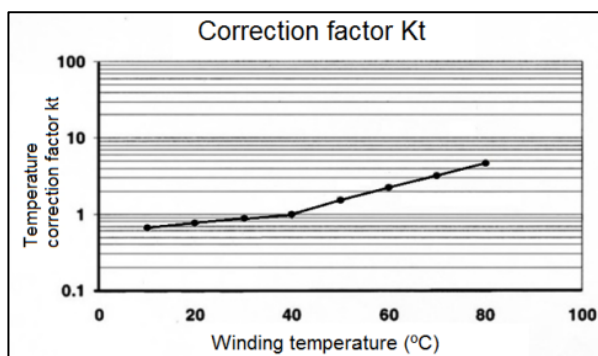

Figure 4.3: Insulation resistance correction factor due to temperature

The values used to generate the curve of Figure 4.3 are shown in Table 4.2.

Table 4.2: Correction factors (Kt) due to temperature

t (°C)	Correction factor (kt)
10	0,7
20	0,8
30	0,9
40	1,0
50	1,5
60	2,3
70	3,3
80	4,6

4.4.6 Polarization Index (P.I)

The polarization index is defined by the ratio between the insulation resistance measured in 10 minutes and the insulation resistance measured in 1 minute. This measurement procedure is always carried out at relatively constant temperatures. The polarization index allows the assessment of the motor insulation conditions.



DANGER

In order to avoid accidents, the winding must be grounded immediately after measuring the insulation resistance.

4.4.7 Recommended Minimum Values

According to IEEE-43 Standard, the recommended minimum values for winding insulation resistance (R.I.) and Polarization Index (I.P.) are shown in Table 4.3:

Table 4.3: Minimum R.I. e I.P. values

Winding voltage	Minimum R.I. (converted to 40°C)	Minimum I.P.
Up to 1000 V	5 MΩ	Not applicable
Greater than 1000 V	100 MΩ	2

4.5 PROTECTIONS

Motors used in continuous duty must be protected against overloads by means of a motor integral device, or an independent protection device, which is generally a thermal relay with rated or adjustable current equal to or below the value obtained by multiplying the full load motor supply current by:

- 1.25 for motors with service factor equal to or above 1.15;
- 1.15 for motors with service factor equal to 1.0.

Motors also have protection devices against overheating (in cases of overloads, locked rotor, low voltage, lack of motor ventilation).

4.5.1 Thermal protections

The over-temperature protections devices are installed on the main stator, bearings and other parts that require temperature monitoring and thermal protection. These sensors must be connected to an external temperature monitoring and protection system. The type of temperature sensor, the connection terminals and the setting temperatures for alarm and shutdown are given in the motor CONNECTION DIAGRAM.

4.5.1.1 Temperature limits for the windings

The temperature of the hottest spot of the winding must be kept below the limit of the insulation thermal class. The total temperature is obtained by the sum of the ambient temperature and the temperature rise (T), plus the difference between the average temperature of the winding and the hottest spot of the winding. The ambient temperature must not exceed 40 °C, in accordance with NBR IEC60034-1 standard. Above this temperature, the working conditions are considered special and the motor specific documentation must be consulted.

Table 4.4 shows the numerical values and the composition of the acceptable temperature at the hottest spot on the winding.

Table 4.4: Insulation class

Insulation class		B	F	H
Ambient temperature	°C	40	40	40
T = temperature rise (temperature measurement method by resistance variation)	°C	80	105	125
Difference between the hottest spot and the average temperature	°C	10	10	15
Total: temperature of the hottest point	°C	130	155	180



ATTENTION

If the motor operates with winding temperatures above the limits of the insulation thermal class, the lifespan of the insulation, and hence that of the motor, will be significantly reduced, or it may even result in the motor burnout.

4.5.1.2 Alarm and trip temperatures

The motor alarm and trip temperatures must be set at the lowest possible value. These temperatures can be determined based on the factory tests or through the motor operating temperature. The alarm temperature can be set 10 °C above the machine operating temperature at full load, always considering the highest ambient temperature on site.



ATTENTION

The alarm and trip values may be determined as a result of experience, but they must not exceed the values indicated in the motor wiring diagram.



ATTENTION

The motor protection devices are listed in the WEG drawing – Connection diagram. Not using these devices is the sole responsibility of the user and, in case of damage to the motor, it will void the warranty.

4.5.1.3 Installation of temperature sensors

To avoid noise in the Pt100 sensor signals, which may cause errors in temperature readings, the following precautions should be taken when installing this equipment:

- The connecting cables must be shielded and the shield must be grounded;
- The installation of the signal cables should be done in a linear manner, avoiding turns and should not be installed near of the power cables.
- The cables connection must be tightened to prevent poor contact or loose.

It is recommended that reading the temperature signal of the Pt100 by specific instruments for temperature acquisition in electric machines, as these instruments have filters capable of eliminate the inherent noise of the application.

4.5.1.4 Temperature and ohmic resistance of the PT100 thermoresistance

Table 4.5 shows the temperature as a function of the ohmic resistance measured across PT100 RTDs.

$$\text{Formula: } \frac{\Omega - 100}{0.386} = \text{°C}$$

Table 4.5: Temperature X Resistance (Pt100)

° C	0	1	2	3	4	5	6	7	8	9
0	100.00	100.39	100.78	101.17	101.56	101.95	102.34	102.73	103.12	103.51
10	103.90	104.29	104.68	105.07	105.46	105.95	106.24	106.63	107.02	107.40
20	107.79	108.18	108.57	108.96	109.35	109.73	110.12	110.51	110.90	111.28
30	111.67	112.06	112.45	112.83	113.22	113.61	113.99	114.38	114.77	115.15
40	115.54	115.93	116.31	116.70	117.08	117.47	117.85	118.24	118.62	119.01
50	119.40	119.78	120.16	120.55	120.93	121.32	121.70	122.09	122.47	122.86
60	123.24	123.62	124.01	124.39	124.77	125.16	125.54	125.92	126.31	126.69
70	127.07	127.45	127.84	128.22	128.60	128.98	129.37	129.75	130.13	130.51
80	130.89	131.27	131.66	132.04	132.42	132.80	133.18	133.56	133.94	134.32
90	134.70	135.08	135.46	135.84	136.22	136.60	136.98	137.36	137.74	138.12
100	138.50	138.88	139.26	139.64	140.02	140.39	140.77	141.15	141.53	141.91
110	142.29	142.66	143.04	143.42	143.80	144.17	144.55	144.93	145.31	145.68
120	146.06	146.44	146.81	147.19	147.57	147.94	148.32	148.70	149.07	149.45
130	149.82	150.20	150.57	150.95	151.33	151.70	152.08	152.45	152.83	153.20
140	153.58	153.95	154.32	154.70	155.07	155.45	155.82	156.19	156.57	156.94
150	157.31	157.69	158.06	158.43	158.81	159.18	159.55	159.93	160.30	160.67

4.5.1.5 Space heater

When the motor is equipped with a space heater to prevent internal water condensation during long periods out of operation, it must be assured that the space heater is energized shortly after turning the motor off, and that it is de-energized before the motor is put into operation.

The values of the space heater supply voltage and power are informed in the connection diagram and in the specific plate affixed to the motor.

4.5.2 Water leak sensor

When requested by the user, the motors can be supplied with a water leak sensor, installed internally in the lower part of the frame. The sensor detects any water leaks from the cooling system into the motor. This sensor must be connected to the control panel, according to the motor connection diagram.



NOTE

The water leak sensor (if any) is installed in the lowest part of the motor.

4.5.3 Water temperature sensor

The temperature sensors installed at the water inlet and outlet (if any) are used to monitor the water temperature.

The water inlet temperature is indicated on a specific plate of the cooling system affixed to the motor frame.

4.6 COOLING

The motor cooling system type may vary according to its application.

Only the correct installation of the motor and of the cooling system can ensure its continuous operation without overheating.



ATTENTION

The protection devices of the cooling system (if any) must be monitored periodically.
The air and/or water inlets and outlets (if any) must not be obstructed, because this could cause overheating and even lead to the motor burnout. For further details, refer to the motor dimensional drawing.

4.6.1 Cooling system characteristics

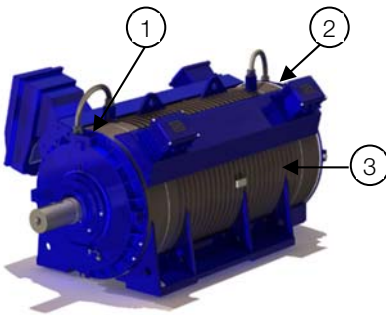

Figure 4.4: WGM motor cooling

Figure 4.4 legend:

1. Water inlet
2. Water outlet
3. Frame with internal channels for water circulation

On water jacket cooled motors, the internal heat is dissipated by the water circulating inside the frame. The water supply system must be installed by the user, complying with the characteristics specified on the cooling system nameplate affixed to the motor frame.



ATTENTION

- In order to ensure proper operation and prevent overheating of the motor, the data of the cooling system informed on the motor cooling system nameplate must be strictly followed;
- The water inlets and outlets must not be obstructed, because it can cause overheating or even lead to burning the motor.

Table 4.6: Cooling system technical characteristics (referential values)

Frame	Flow (L/min.)	Maximum load loss (bar)	Maximum working pressure (bar)
315	35	1	4
355	45	1	4
400	55	1	4
450	80	1	4
500	90	1	4
560	100	1	4

4.6.2 Cooling water characteristics

Make use of treated industrial water with the following characteristics:

- pH: 6.0 a 8.0;
- Chlorides: < 40 ppm;
- Sulphates < 50 ppm;
- Nitrates < 10 ppm;
- Iron: < 0.2 ppm
- Ammonia: < 10 ppm;
- Conductivity: < 500µS/cm;
- Maximum size of charged particles in the water: ≤ 0.1mm.



ATTENTION

In an emergency case, the motor can also be cooled with seawater for up to a maximum of 30 consecutive days; however, that can only be done twice during the motor useful life. After the operation with seawater, it is necessary to clean the cooling circuit with treated industrial water.

4.6.2.1 Cooling water temperature

Motors cooled by water jacket are able to operate with the cooling water temperature in the inlet as specified in the project and indicated on the plate affixed to the motor.

4.6.3 Protective devices



ATTENTION

The cooling system protection devices must be monitored periodically. The water inlet and outlet must not be obstructed, because it can cause overheating or even lead to burning the motor. For more details, consult the motor DIMENSIONAL DRAWING.

4.7 ELECTRICAL ASPECTS

4.7.1 Electrical connections



ATTENTION

Analyze the electrical connection diagram supplied with the motor carefully before beginning the connection of the main cables and those of the accessories. For the electrical connection of auxiliary equipment, refer to their specific manuals.

4.7.1.1 Main electrical connections

The location of stator terminal box is identified in the specific motor DIMENSIONAL DRAWING.

The location of stator terminal box is identified in the specific motor DIMENSIONAL DRAWING.

Make sure the cross section and insulation of the main connection cables are suitable for the motor current and voltage.

The motor must rotate in the rotation direction specified on the nameplate and on the sign arrow affixed to the motor drive end.



NOTE

The rotation direction is, by convention, determined looking to the shaft end at the motor drive end.

Motors with a single rotation direction must only rotate in the indicated direction.

In order to operate the motor in the rotation direction opposite to the specified, consult WEG.



ATTENTION

Before making the connections between the motor and the power supply, it is necessary to perform a careful measurement of the winding insulation resistance.

In order to connect the motor main power supply cables, unscrew the cover of the stator terminal box, cut the sealing rings (standard motors without cable gland) according to the diameter of the cables to be used and insert the cables in the sealing rings. Cut the power supply cables to the necessary length, strip the ends and mount the cable lugs that will be used.

4.7.1.2 Grounding

The motor frame and the main terminal box must be grounded before connecting the motor to the supply system.

Connect the metallic sheath of the cables (if any) to the common grounding conductor. Cut the grounding conductor to the proper length and connect it to the terminal in the terminal box and/or on the frame.

Fasten all connections firmly.



ATTENTION

Do not use washers made of steel or other materials with low electrical conductivity to fasten the cable lugs.

4.7.2 Connection diagrams

4.7.2.1 Connection diagrams according to IEC60034-8

The following connection diagrams show the terminal identification in the terminal box and the possible connections for the motors.

4.7.2.1.1 Stator connection diagrams

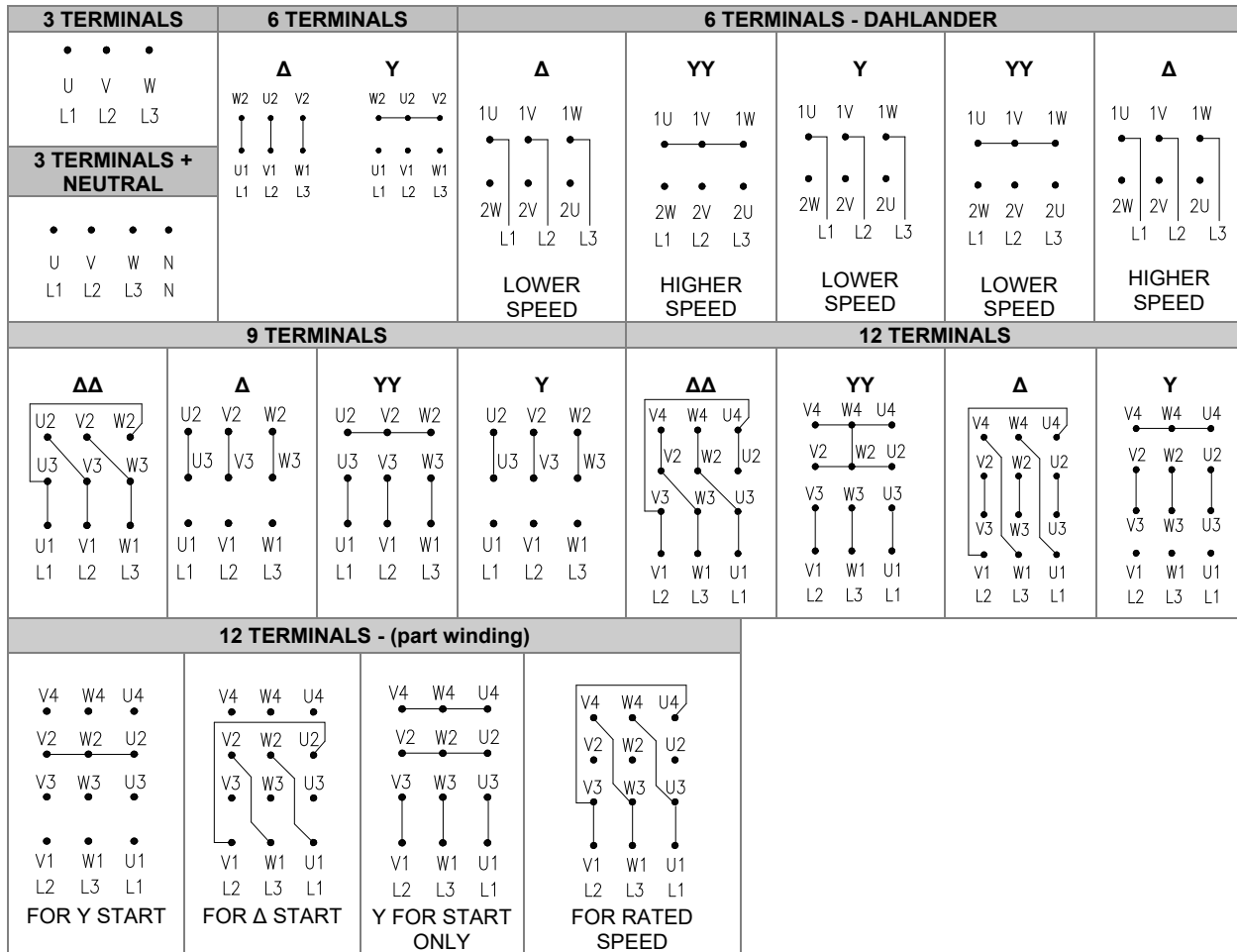

NOTE

When two or more motor connecting cables are used in parallel in order to divide the electric current, the identification of these cables is made with an additional suffix separated by a hyphen, according to Figure 4.5.

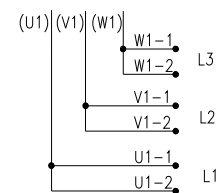
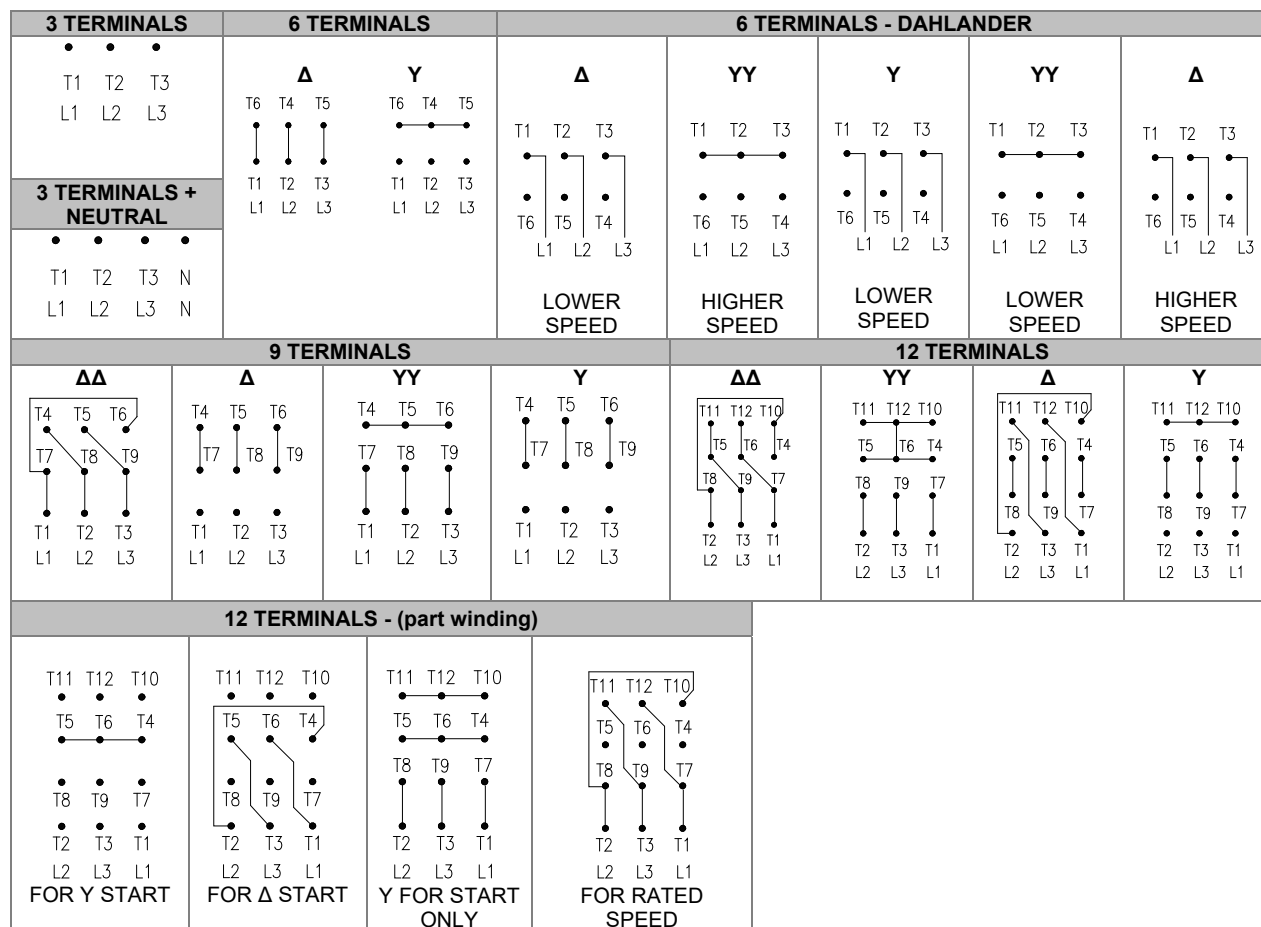

Figure 4.5: Parallel connections

4.7.2.2 Connection diagrams according to NEMA MG1

4.7.2.2.1 Stator connection diagrams



NOTE

When two or more motor connecting cables are used in parallel in order to divide the electric current, the identification of these cables is made with an additional suffix separated by a hyphen, according to Figure 4.6.

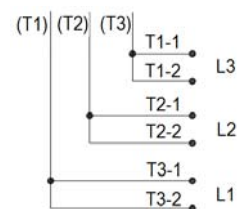

Figure 4.6: Parallel connections

4.7.2.3 Rotation direction

- The rotation direction is indicated on the nameplate and must be observed looking to the shaft end at the motor drive end. The rotation direction must be checked before coupling the motor to the driven machine;
- Motors with terminal identification and connections as described in this manual have clockwise rotation direction, according to IEC60034-8 standard;
- In order to invert the rotation direction, it is necessary to swap any two phases;
- Motors with a single rotation direction, as indicated on the nameplate and on sign plate affixed to the frame, have unidirectional fan and must be operated only in the specified rotation direction. In order to invert the rotation direction of unidirectional motors, consult WEG.

4.7.2.4 Accessory connection diagrams

For the correct installation of the accessories, refer to the drawing in the specific CONNECTION DIAGRAM of the motor.

4.8 MECHANICAL ASPECTS

4.8.1 Base

- The base or structure where the motor will be installed must be sufficiently rigid, flat, free of external vibration and capable to withstand the mechanical loads to which it will be submitted;
- If the dimensioning of the base is not carefully executed, this may cause vibration in the base, on the motor and the driven machine;
- The base structural design must be done based on the dimensional drawing, on the information about foundation mechanical loads, and on the motor anchoring method.
- The customer is responsible for the design and construction of the foundation according to the requirements described in Natural frequency of the base.



ATTENTION

Place shims of different thicknesses between the motor supporting surfaces and the base in order to allow a precise alignment.



NOTE

The user is responsible for dimensioning and building the foundation where the motor will be installed.

4.8.2 Base loads

Based on Figure 4.7, base loads can be calculated by the equations:

$$F_1 = +0.5.m.g. + \frac{(4C \max)}{(A)}$$

$$F_2 = +0.5.m.g. - \frac{(4C \max)}{(A)}$$

Where: F1 and F2 - Reaction of the feet on the base (N)
g - Acceleration of gravity (9.81m/s²)
 m - Motor mass (kg)
 Cmax - Maximum torque (Nm)
 A - Obtained from the motor dimensional drawing (m)

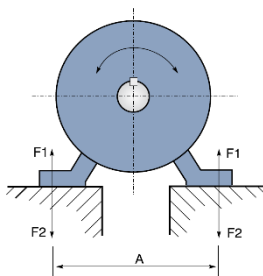

Figure 4.7: Foundation loads

4.8.3 Base types

4.8.3.1 Concrete base

The type and size of the foundation, bolts and anchoring plates depend on the motor size and type.

Example of base preparation:

- Remove all the dirt from the foundation to ensure a proper binding between the foundation blocks and the mortar.
- Fasten the foundation blocks to the motor feet using bolts.
- Use shims of different thicknesses (total thickness of approximately 2 mm) between the motor feet and the foundation surfaces in order to obtain a precise vertical alignment.
- In order to ensure the centralization of the bolts regarding the foot holes, use a metallic or a cardboard (prespan) sheet as bushing, making possible a precise horizontal alignment later.
- **Place shims or leveling bolts under the foundation blocks** to ensure proper leveling and perfect alignment of the motor with the driven machine. After the mortar is applied, the alignment must be precisely controlled. Occasional small corrections may be done with washers or metal sheets or by readjusting the clearance of the fastening bolts.
- Tighten all the fastening bolts firmly. Make sure the motor feet surfaces are supported evenly without distorting the motor frame.

For precise fixation, introduce two tapered pins after finishing the test.

4.8.3.2 Sliding base

In case of pulley drive, the motor must always be mounted on a sliding base (rails), and the lower part of the belt must be tightened.

The rail closer to the driving pulley must be mounted so that the positioning bolt is placed between the motor and the driven machine. The other rail must be mounted with the bolt in the opposite position, as shown in Figure 4.8. The motor is bolted on rails and positioned on the foundation.

The driving pulley is then aligned so that its center and the center of the driven pulley are in the same plane, and the motor and machine shafts are perfectly parallel. The belt must not be stretched too much. After the alignment, the rails are fixed.

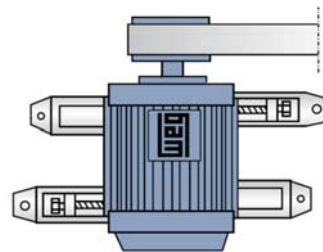

Figure 4.8: Sliding base

4.8.3.3 Metal base

The motor must rest evenly on the metal base in order to prevent deformations of the frame. Occasional errors in the height of the surface that supports the motor feet can be corrected with shims (a maximum height of 2 mm is recommended).

Do not remove the machines from the common base to align them. The base must be leveled on the foundation by using spirit levels or other leveling devices.

When a metal base is used to align the height of the motor shaft end with the machine shaft end, it must be leveled on the concrete base.

After the base has been leveled, the anchor bolts tightened and the couplings checked, then the metal base and the anchor bolts are cemented.

4.8.3.4 Anchor bolts

Anchor bolts are devices to fasten the motors directly on the foundation when the motors are applied with elastic coupling. This coupling type is characterized by the absence of loads on the bearings.

The anchor bolts must neither be painted, nor present rust, since that impairs the adhesion to the concrete, loosening them.

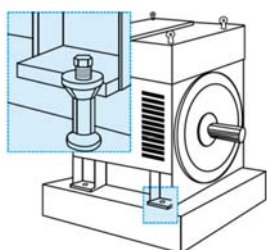

Figure 4.9: Anchor bolts

4.8.4 Natural frequency of the base

In order to ensure a safe operation, the motor must be precisely aligned with the coupled equipment and both must be properly balanced.

As a requirement, the motor installation base must be flat and meet the requirements of DIN 4024-1 standard. In order to verify if the criteria of the standard are being met, the following potential vibration excitation frequencies generated by the motor and coupled machine must be checked:

- The motor rotation frequency;
- The double of the rotation frequency;
- The double of the motor electric frequency.

According to DIN 4024-1 standard, the natural frequencies of the base or foundation must be away from these potential excitation frequencies, as specified next:

- The first natural frequency of the base or foundation (first order natural frequency of the base) must be out of the range from 0.8 to 1.25 times any of the potential excitation frequencies above;
- The other natural frequencies of the base or foundation must be out of the range from 0.9 to 1.1 times any of the potential excitation frequencies above.

4.8.5 Leveling

The motor must rest on a surface with flatness of up to 0.08 mm/m.

Verify whether the motor is perfectly leveled, both in the vertical and horizontal planes. Make the proper adjustments by placing shims under the motor. The motor leveling must be checked with proper equipment.



NOTE

At least 75% of the motor foot support surfaces must rest on the motor base.

4.8.6 Alignment

The motor must be correctly aligned with the driven machine.



ATTENTION

Incorrect alignment can damage the bearings, generate excessive vibration and even break the shaft.

The alignment must be done according to the coupling manufacturer recommendations.

The motor and driven machine shafts must be aligned in the axial and radial directions, as shown in Figure 4.10 and Figure 4.11.

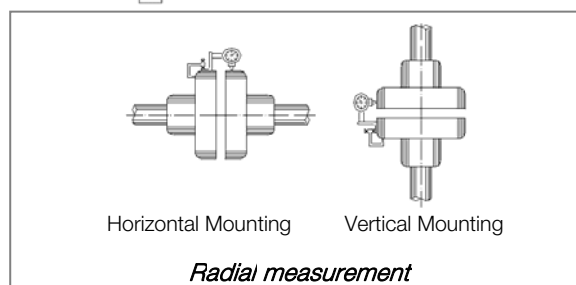
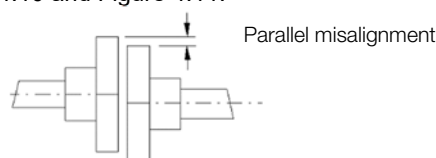

Figure 4.10: Parallel alignment

Figure 4.10 shows the parallel misalignment of the two shaft ends and the practical way to measure it by using suitable dial gauges.

The measurement is performed in four points 90° away from each other with the two half-couplings rotating together in order to eliminate effects of support surface irregularities on the dial gauge tip. Choosing the upper vertical point as 0°, half of the difference between the dial gauge measurements at the 0° and 180° points represents the vertical coaxial error. In case of deviation, it must be corrected by adding or removing leveling shims. Half of the difference between the dial gauge measurements at the 90° and 270° points represents the horizontal coaxial error.

These measurements indicate when it is necessary to lift or lower the motor, or move it to the right or to the left on the drive end in order to eliminate the coaxial error.

Half of the maximum difference among the dial gauge measurements in a complete rotation represents the maximum eccentricity found.

The misalignment in a complete shaft rotation, with rigid or semiflexible coupling, cannot exceed 0.03 mm. When flexible couplings are used, greater values than those indicated above are acceptable, provided that they do not exceed the value allowed by the coupling manufacturer. It is recommended to keep a safety margin for these values.

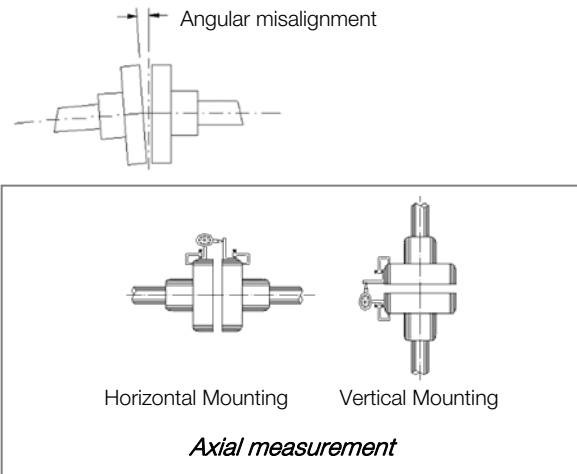

Figure 4.11: Angular alignment

Figure 4.11 shows the angular misalignment and a practical form to measure it. The measurement is done in four points 90° away from each other, with the two half-couplings rotating together in order to eliminate effects of support surface irregularities on the dial gauge tip. Choosing the upper vertical point as 0°, half of the difference between the dial gauge measurements at the 0° and 180° points represents the vertical misalignment. In case of deviation, it must be corrected by adding or removing alignment shims. Half the difference between the dial gauge measurements at the 90° and 270° points represents the horizontal misalignment, which must be properly corrected by displacing the motor in the lateral/angular direction. Half of the maximum difference among the dial gauge measurements in a complete rotation represents the maximum angular misalignment found. The misalignment in a complete shaft rotation, with rigid or semi flexible coupling, cannot exceed 0.03 mm. When flexible couplings are used, greater values than those indicated above are acceptable, provided that they do not exceed the value allowed by the coupling manufacturer. It is recommended to keep a safety margin for these values.

In the alignment/leveling, the influence of the temperature on the motor and the driven machine must be taken into account. Different expansions of the parts may change the alignment/leveling conditions during operation.

4.8.7 Doweling

After aligning the set and having assured a perfect alignment (both, hot and cold), the motor must be doweled to the anchor plate or to the base, as shown in Figure 4.12.

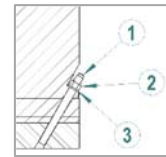

Figure 4.12: Dowel pin set

Figure 4.12 legend:

1. Dowel pin (optional supply)
2. Nut (optional supply)
3. Washer (optional supply)



NOTE

For the doweling, the motor has a pre-hole with $\varnothing 9$ mm, which must be first expanded to $\varnothing 11.5$ mm, and then reamed to $\varnothing 12$ mm with a taper of 1:50.

4.8.8 Couplings

Only proper couplings, which convey only torque without generating transversal forces, must be used. For both flexible and rigid couplings, the shaft centers of the coupled machines must be in a single line. Flexible couplings mitigate the effects of residual misalignments and prevent transmission of vibration between the coupled machines, which does not occur when rigid couplings are used.

The coupling must be mounted or removed with the aid of proper devices and never by means of rudimentary tools, such as hammers, sledgehammers, etc. Follow the manufacture's instructions when mounting or removing couplings or other drive elements and cover them with a touch guard. For trial run in uncoupled state, lock or remove the shaft end key. Avoid excessive radial and axial bearing loads (note manufacture's documentation). The balance of the machine is indicated as H= half and F= full key. In half key cases coupling must be half key balanced without a key. In case of protruding, visible part of the shaft end key, establish mechanical balance.



ATTENTION

Dowel pins, nuts, washers and leveling shims may be supplied with the motor, when requested in the purchase order.



NOTES

The user is responsible for the motor installation (unless otherwise specified by commercial agreement). WEG is not liable for damages to the motor, associated equipment and installation occurred because of:

- Transmission of excessive vibration;
- Poor installations;
- Faulty alignment;
- Improper storage conditions;
- Noncompliance with the instructions before start-up;
- Incorrect electrical connections.

4.8.8.1 Direct coupling

Because of issues about cost, space economy, problems with belt sliding and more safety against accidents, direct coupling must be used whenever possible. Also, direct coupling is preferable in case of transmission with reduction gearing.



ATTENTION

Align the shaft ends carefully, and, whenever possible, use flexible coupling, leaving a minimum clearance (E) of 3 mm between the couplings, as shown in Figure 4.13.

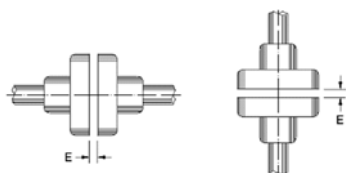

Figure 4.13: Axial clearance of the coupling (E)

4.8.8.2 Gear coupling

Gear couplings badly aligned generate vibration in the transmission itself and in the motor. Therefore, caution must be taken so that the shafts be perfectly aligned, rigorously parallel in case of spur gear transmissions and in a correct angle in case of transmissions by bevel or helical gears.

The gear teeth meshing can be controlled with the insertion of a paper strip, on which the trace of all teeth shows up after a gear turn.

4.8.8.3 Belt drive

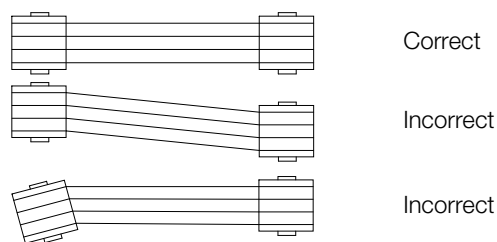

Figure 4.14: Belt drive

When a reduction or increase in speed is required, the belt transmission is the most indicated.

In order to avoid unnecessary stress on the bearings, the shafts and the pulleys must be perfectly aligned.

Belts that operate obliquely transmit alternating jolts to the rotor and will be able to damage the bearings.

Belt slippage can be prevented by applying a resin like material, such as pitch for instance.

The belt tension must be just enough to prevent slippage during operation.



NOTE

Belts too tensioned increase the load on the shaft end, causing vibration and fatigue, or even the break of the shaft.

Avoid using too small pulleys, since they cause flexion of the motor shaft because of the belt traction force that, which increases as the diameter of the pulley decreases.



ATTENTION

Consult WEG for the correct sizing of the pulley.



NOTE

Always use properly balanced pulleys. Avoid extra key lengths, because they increase the unbalancing mass and increase the motor vibration.

5 STARTING

5.1 DIRECT ON-LINE STARTING

It is the simplest and most economically feasible method; however, it must only be used when the starting current does not affect the power grid.

Bear in mind that the starting current of motors may reach 6 to 7 times the rated current value. Therefore, it must be ensured that this current (I_p) will not affect the supply of other consumers because of the high voltage drop in the power grid.

The machine must be started/can be started when the temperature recorded at PT-100's of the three phases is equal to or greater than -20°C

When turning off the machine the heating resistors of the temperature rise circuit must be turned off.

There is an interlocking system so that the main machine's drive circuit breaker is only activated when the temperature recorded on the winding is greater than or equal to -20°C .

This requirement is met in one of the three situations:

- a) When the power grid is "strong" enough and the motor current is negligible in relation to the grid capacity.
- b) The motor is always started without load, which reduces the starting time and, in turn, the duration of the starting current and the momentary voltage drop, which is acceptable for the other consumers of the grid;
- c) When DOL starting is duly authorized by the local electric utility company.

When the motor starting current is high, the following detrimental consequences may occur:

- a) The high voltage drop in the power supply system may cause interference in equipment installed in this system;
- b) The protection system (cables, contactors) must be oversized, increasing the installation costs.



NOTE

In some cases, there is an imposition of the electric utility companies that limits the voltage drop of the grid.

5.2 DIRECT ONLINE STARTING FREQUENCY

Since induction motors have a high starting current, the time spent to accelerate loads with high inertia results in a quick rise of the motor temperature. If the intervals between successive starts are too short, the temperature of the windings will rise quickly, reducing their useful life or even burning them. The NBR 17094 and IEC60034-1 standards establishes a minimum starting duty to which the motors must be able to comply:

- a) Two successive starts: the first one with the motor cold, i.e., with its windings at ambient temperature, and the second one right afterwards, but only after the motor has decelerated to a full stop;
- b) One start with the motor hot, i.e., with the windings at continuous duty temperature.

The first condition simulates the case in which the first motor start is aborted, for instance, by the trip of the motor protection, when a second motor start is permitted right afterwards.

The second condition simulates the case of an accidental motor shutdown under normal operation, for instance, by power outage, when the motor restart is allowed right after the power is reestablished.



NOTE

Special starting conditions must be checked in the specific motor documentation before starting the procedure.

5.3 LOCKED ROTOR CURRENT

The motor nameplate indicates the value of I_p/I_n , which is the relation between the starting current and the rated current of the motor.

5.4 STARTING WITH REDUCED CURRENT

If direct online starting is not possible, the following starting systems can be used in order to reduce the motor starting current.

- Star-delta starter;
- Series-parallel starter;
- Autotransformer starter;
- Static starter or soft-starter;
- Frequency inverter.

6 COMMISSIONING

When the motor is started for the first time or after a prolonged standstill, several aspects must be considered besides the regular operation procedures.



ATTENTION

- Avoid any contact with electric circuits;
- Even low-voltage circuits may be life threatening;
- In any electromagnetic circuit, overvoltage may occur under certain operating conditions;
- Do not open an electromagnetic circuit suddenly, because the presence of an inductive discharge voltage may break the insulation or injure the operator;
- In order to open those circuits, disconnect switches or circuit breakers must be used.

6.1 PRELIMINARY INSPECTION

Before the first motor start or after long periods out of operation, the following items must be inspected:

1. Check if all the motor fastening bolts are tightened;
2. Measure the winding insulation resistances, making sure they are within the specified values;
3. Check if the motor is clean and if the packages, measuring instruments and alignment devices were removed from the motor operating area;
4. Check if coupling connecting components are in perfect operating conditions, duly tightened and greased, where necessary;
5. Check if the motor is correctly aligned;
6. Check if the bearings are properly lubricated. The lubricant must be of the type specified on the nameplate;
7. Inspect connections and parameterization of accessories and protections;
8. Check if all electrical connections comply with the motor connection diagram;
9. The cables connected to the stator and rotor main terminals must be properly tightened in order to prevent their short-circuit or loosening;
10. The terminal box covers must be correctly fastened;
11. Inspect the operation of the motor cooling water supply system;
12. Motor air inlets and outlets must be unobstructed;
13. The moving parts of the motor must be protected to prevent accidents;
14. Check if the power supply voltage and frequency comply with the data on the motor nameplate;

6.2 FIRST STARTING

After all preliminary inspections have been carried out proceed according to the directions presented next in order to perform the first start of the uncoupled motor:

1. Turn off the space heaters;
2. Set the protections in the control panel;
3. Turn on the cooling water system, checking the necessary flow and pressure, and the temperature of the cooling water;
4. Rotate the motor shaft slowly in order to check that no part is being dragged or any abnormal noises are occurring;
5. Start the motor with no load, making sure that it rotates smoothly without strange noises;
6. Check the rotation direction with the motor uncoupled from the load. In order to invert the rotation direction of the motor, just invert the connection of any two phases;
7. Keep the motor rotating at rated speed and write down the bearing temperatures at 1-minute intervals until they become constant. Any sudden increase in bearing temperature indicates lubrication or friction surface abnormality;
8. Monitor the bearing temperatures and the vibration levels. If there is a significant variation of any value, interrupt the motor starting, identify possible causes and make the necessary corrections;
9. When the bearing temperatures stabilize, it is possible to proceed to the other motor operation steps.



ATTENTION

The noncompliance with the procedures described in section 6.2 may impair the motor performance, cause damages and even lead to its burnout, voiding the warranty.

6.3 OPERATION

The operating procedures vary considerably depending on the motor application and the type of control equipment used.

The general procedures are described in this manual.

For the control system operating procedures, refer to the specific manual of this equipment.

6.3.1 General

After a first successful starting test, couple the motor to the driven load, and then the starting procedure can be reinitiated, as follows:

- Start the motor coupled to the load until its temperature stabilizes and check for unusual noises, abnormal vibrations or excessive heating. If significant vibration variations occur regarding the initial operation condition until the condition after reaching thermal stability, then it is necessary to check the alignment and the leveling.
- Measure the current consumption and compare it to the value given on the nameplate.
- In continuous duty, without load variation, the measured current must not exceed the value indicated on the nameplate multiplied by the service factor;
- All the instruments and devices for measurement and control must be permanently monitored to detect occasional alterations, determine their causes and make the proper corrections.

6.3.2 Temperatures

- The temperatures of the bearings, stator winding and cooling system must be monitored while the motor is operating.
- These temperatures must stabilize within 4 to 8 hours of operation.
- The stator winding temperature depends on the machine load; therefore, the driven load must also be monitored during the motor.

6.3.3 Bearings

The system start, as well as the first hours of operation, must be monitored carefully.

- During the first starting, it is important to pay attention to unusual vibrations or noises; If the bearing is not working silently and smoothly, shut the motor down, identify the cause and correct it;
- In case of overheating, the motor must be shut down immediately for the inspection of bearings and temperature sensors, and the correction of possible causes;
- After the bearing temperatures stabilize, check if there are no leaks through the plugs, gaskets or shaft end.

6.3.4 Cooling system



ATTENTION

The motor cannot be operated without water in the cooling system.

- Adjust the water flow and pressure, as indicated on the plate affixed to the motor;
- For operation control purposes, it is recommended that the cooling water temperatures at the inlet and outlet as well as the differential pressure at the water inlet and outlet be measured and recorded periodically;
- These values must be periodically compared to the original value, and an increase in the pressure differential or a water temperature rise indicates the need for cleaning the motor water circuit.

6.3.5 Vibration

The motors are balanced at the factory in compliance with the vibration limits established by IEC60034-14, NEMA MG1 – Part 7 and NBR 11390 standards (except when the purchase contract specifies different values). The vibration measurements are carried out on the NDE and DE bearings, in the vertical, horizontal and axial directions. When the customer sends the half coupling to WEG, the motor is balanced with the half coupling mounted on the shaft. Otherwise, according to the standards above, the motor is balanced with half-key (i.e., the key slot is filled with a bar of the same width, thickness and height of the key slot during the balancing operation).

The maximum vibration levels met by WEG for running motors are given in the wiring diagram.

The main vibration causes are:

- Misalignment between the motor and the driven equipment;
- Improper fastening of the motor to the base, with “loose shims” under one or more motor feet, and loose fastening bolts;
- Improper or insufficiently rigid base;
- External vibrations proceeding from other equipment.



ATTENTION

Operating the motor with vibration above the values contained in its wiring diagram may impair its useful life and/or performance.

6.3.6 Shutdown

In order to shut down the motor, proceed as follows:

- Reduce the load of the driven equipment, if possible;
- Open the main circuit breaker.

After the motor stops completely:

- Shut down the motor cooling water supply system;
- Switch on the space heaters. They must be kept ON until the next motor operation.



DANGER

Even after switching the motor off, while the rotor is rotating, there is danger to life by touching any of the motor active parts.



ATTENTION

The terminal boxes of motors equipped with capacitors must not be opened before the discharge time.
Discharge time of the capacitors: five minutes after shutting down the motor.

7 MAINTENANCE

7.1 GENERAL

A proper maintenance program for electric motors includes the following recommendations:

- Keep the motor and the associated equipment clean;
- Measure the winding insulation resistance periodically;
- Measure the temperature of windings, bearings and cooling system periodically;
- Check the wear, operation of the lubrication system and useful life of the bearings;
- Measure the motor vibration levels;
- Inspect the cooling system;
- Inspect associated equipment;
- Inspect all the motor accessories, protections and connections, ensuring that they are operating properly;



ATTENTION

The resistors must be de-energized before opening the connection box cover, whenever maintenance is carried out.



ATTENTION

Noncompliance with the recommendations of section 7.1 may cause undesired stoppages of the equipment.

The frequency of such inspections depends on the local application conditions.

Every time that it becomes necessary to transport the motor, the shaft must be properly locked to prevent damages to the bearings. Use the device supplied with the motor to lock the shaft.

If the motor requires reconditioning or replacement of any damaged part, consult WEG.

7.2 GENERAL CLEANING

- Keep the frame clean, without external accumulation of oil or dust, in order to facilitate the heat exchange with the environment;
- The inside of the motor must also be kept clean, free of dust, debris and oils;
- For cleaning, use brushes or clean cotton cloths. If the dust is not abrasive, the cleaning must be done with an industrial vacuum cleaner, "aspiring" the dirt from the fan cover and the dust accumulated on the fan blades and on the frame;
- Debris impregnated with oil or moisture can be removed with a cloth soaked in appropriate solvents;
- Clean the terminal boxes when necessary. Terminals and connectors must be kept clean, free of rust and in perfect operating conditions. Avoid the presence of grease or verdigris in the connection parts.

7.3 WINDING MAINTENANCE

To obtain more satisfactory operation and a longer life of the motor, the windings should be inspected and cleaned annually.

7.3.1 Winding inspection

Yearly, the windings must be submitted to a complete visual inspection, recording and repairing all and every damage or defect observed.

The winding insulation resistance measurements must be done at regular intervals, especially during humid weather and after prolonged motor stoppages.

Low values or sudden variations in the insulation resistance must be investigated.

The windings must be submitted to complete visual inspections at frequent intervals, recording and repairing all and every damage or defect observed.

The winding insulation resistance can be increased up to an adequate value in the points where it is low (as a result of excessive dust and moisture) by means of the dust removal and by drying the winding moisture.

7.3.2 Winding cleaning

In order to obtain a more satisfactory operation and a longer useful life of the insulated windings, it is recommended to keep them free of dirt, oil, metal dust, contaminants, etc. Therefore, it is necessary to inspect and clean the windings periodically, according to the recommendations of the "Maintenance Plan" of this manual. If reimpregnation is necessary, consult WEG. The windings may be cleaned with an industrial vacuum cleaner with a non-metallic crevice tool or just a dry cloth.

For extreme dirt conditions, it may be necessary to use a proper liquid solvent for cleaning. This cleaning must be quick to prevent prolonged exposure of the windings to the solvent effects. After being cleaned with solvents, the windings must be completely dried. Measure the insulation resistance and the polarization index in order to assess the winding insulation conditions. Winding drying time after cleaning varies depending on the weather conditions such as temperature, humidity, etc.



DANGER

Most solvents currently used are highly toxic and/or flammable.

Solvents must not be used in the straight parts of the coils of high-voltage motors, because they may affect the protection against corona effect.

7.3.3 Inspections

The following inspections must be carried out after the windings are carefully cleaned:

- Check the insulations of the winding and connections;
- Check if spacers, bindings, slot wedges, bandages and supports are properly fixed;
- Check for breaks, faulty welds, short-circuit between turns and against the frame in the coils and connections. In case any fault is detected, consult WEG.
- Ensure that all cables are properly connected and that terminal fixation components are duly tightened. Retighten, if necessary.

7.3.4 Reimpregnation

If any layer of resin on the windings is damaged during cleaning or inspection, such parts must be corrected with adequate material (in this case, consult WEG).

7.3.5 Insulation Resistance

The insulation resistance must be measured after the completion of all of the maintenance procedures.



ATTENTION

Before putting the motor back into operation, it is essential to measure the winding insulation resistance and ensure that the measured values meet the specifications.



NOTE

When the motor is equipped with a water leak sensor, it also serves as a drain, and must be removed in order to drain the condensed water from inside the motor.

7.4 COOLING SYSTEM MAINTENANCE

- Inspect and clean the cooling channels periodically according to the maintenance plan of this manual;
- The external part of the frame and the water connections must be kept in good conditions;
- If there is a freezing risk, antifreeze additive must be used in the cooling water.
- Add additives to the cooling water in proper quantities for protection against corrosion and algae growth;
- The type and number of additives used must be specified by the manufacturer of these additives and in accordance with the environmental conditions where the motor is installed.

7.5 VIBRATION

Any evidence of increase in the unbalance or vibration of the motor must be investigated immediately.



ATTENTION

After torquing or disassembling any machine screw, it is necessary to apply Loctite.

7.6 MOTOR OUT OF OPERATION

When the motor is stopped, water may condense inside. In horizontal motors, this water must be removed through the drain located at the lowest point of the end shields, as shown in Figure 7.1.

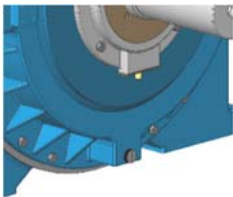

Figure 7.1: Drain of horizontal motors

In vertical motors, the drain is located in the motor lower end shield, as show in Figure 7.2.

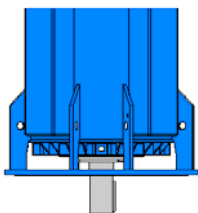

Figure 7.2: Drain of vertical motors

- If the motor remains stopped in environments with negative temperatures, the freezing of the motor cooling circuit water must be prevented. This can be done by draining all the water from the frame or by using antifreeze additives in the water;
- In order to remove the water from the frame of horizontal motors, disconnect the water supply hoses and inject compressed air into one of the water inlets until it drains out completely;
- In order to remove the water from the frame of vertical motors, disconnect the water supply hose and allow it to drain completely through the lower opening;
- For storage during long periods, follow the procedures described in this manual;
- Turn on the space heaters so that the temperature inside the motor be kept slightly above the ambient temperature, avoiding water condensation and consequent drop of the winding insulation resistance and oxidation of metallic parts.

7.7 SHAFT GROUNDING DEVICE

The shaft grounding brush (if any) avoids the circulation of electric current through the bearings, which is detrimental to their operation. The brush is put in contact with the shaft and connected by a cable to the motor frame, which must be grounded. Make sure that the brush holder fastening and its connection to the frame have been made correctly.

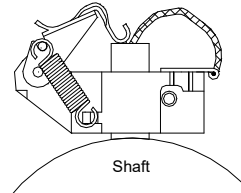

Figure 7.3: Shaft grounding brush

Drying oil is used to protect the motor shaft against rust during transportation. In order to ensure the proper operation of the grounding brush, this oil, as well as any residue between the shaft and the brush, must be removed before starting the motor. The brush must be constantly monitored during operation, and it must be replaced by another one of the same quality (granulation) at the end of its useful life.

7.8 ENCODER MAINTENANCE

The correct installation of the encoder (if any) is very important for its operation. Both disassembly and assembly must be done by skilled and trained personnel, according to the procedures contained in the specific manual of the equipment manufacturer. If any further explanations are necessary, consult WEG.

7.9 BEARING MAINTENANCE

7.9.1 Grease-lubricated rolling bearings



NOTE

The rolling bearing data, amount and type of grease, and lubrication intervals are informed on a bearing nameplate affixed to the motor.

The bearings shall be relubricated annually or according to the lubrication interval stated on the bearings nameplate, whichever occurs first.

- The informed lubrication intervals, consider a 70 °C working temperature of the rolling bearing;
- Based on the operating temperature ranges listed in Table 7.1, apply the following correction factors for the rolling bearing lubrication intervals:

Table 7.1: Reduction factor for lubrication intervals

Bearing operating temperature	Reduction factor
Below 60 °C	1.59
Between 70 and 80 °C	0.63
Between 80 and 90 °C	0.40
Between 90 and 100 °C	0.25
Between 100 and 110 °C	0.16

7.9.1.1 Instructions for lubrication

The lubrication system was designed in such a way that during the lubrication of the rolling bearings, all the old grease is removed from the rolling bearing races and expelled through a drain which enables the exit of the grease, but prevents the ingress of dust or other harmful contaminants.

This drain also prevents damage to the rolling bearings by excessive lubrication.

It is recommended to make the lubrication with the motor in operation in order to ensure the renewal of the grease in the rolling bearing housing.

If that is not possible due to the presence of rotating parts near the grease nipple (pulleys, etc.) which may put the operator at risk, follow the procedures below:

- With the motor stopped, inject approximately half of the total intended amount of grease and operate the motor for approximately one minute at full speed;
- Stop the motor and inject the rest of the grease.



ATTENTION

The injection of all the grease with the motor stopped may lead to the penetration of part of the lubricant into the motor through the internal seal of the rolling bearing cap; It is important to clean the grease nipples prior to lubrication in order to prevent foreign materials from being dragged into the rolling bearing. For lubrication, use only manual grease gun.

7.9.1.2 Procedures for rolling bearing relubrication

1. Remove the drain plug;
2. Clean with a cotton cloth around the hole of the grease nipple;
3. With the rotor operating, inject the grease with a manual grease gun until grease starts coming out from the drain or until the proper amount of grease, informed in Table 7.3, has been injected.
4. Keep the motor running long enough so that the grease excess passes through the drain;
5. Inspect the bearing temperature to make sure there was no significant change;
6. Put the drain plug back in place.

7.9.1.3 Rolling bearing relubrication with drawer device for grease removal

In order to relubricate the bearings, the old grease is removed by means of the device with a drawer installed on each bearing.

Lubrication procedure:

1. Before starting the lubrication of the bearing, clean the grease nipple with a cotton cloth;
2. Remove the rod with drawer to remove the old grease, clean the drawer and put it back in place;
3. With the motor running, inject the amount of grease specified on the rolling bearing nameplate by means of a manual grease gun;
4. The excess of grease comes out through the bearing lower drain and is deposited in the drawer;
5. Leave the motor running long enough for the grease excess to drain;
6. Remove the excess of grease, by pulling the drawer rod and cleaning the drawer. This procedure must be repeated as many times as necessary until the drawer no longer retains grease;
7. Inspect the bearing temperature to ensure that there was no significant change.

7.9.1.4 Type and amount of grease

The relubrication of the bearings must always be done with the **original grease**, specified on the bearing nameplate and in the documentation of the motor.



ATTENTION

WEG does not recommend the use of greases different from the motor original grease.

It is important to perform a correct lubrication, i.e., to apply the correct grease and in the proper quantity, because either poor or excessive lubrication will damage the rolling bearings.

Excessive amount of grease cause temperature increase, due to the great resistance it offers to the movement of the bearing rotating parts. Consequently, due to the heating, the grease can completely lose its lubricating characteristics.

7.9.1.5 Alternative greases

If it is not possible to use the original grease, the alternative greases listed in Table 7.2 can be used, under the following conditions:

1. The motor speed must not exceed the limit speed of the grease, according to the type of rolling bearing, as informed in Table 7.3;
2. The bearing lubrication interval must be corrected by multiplying the interval informed on the bearing nameplate by the multiplication factor informed in Table 7.2;
3. Use the correct procedure to change the grease, according to section 7.9.1.6 of this manual.

Table 7.2: Options and characteristics of the alternative greases for regular applications

Manufacturer	Grease	Constant operating temperature (°C)	Multiplication factor
Exxon Mobil	UNIREX N3 (Lithium Complex Soap)	(-30 to +150)	0.90
Shell	GADUS S2 V100 3 (Lithium Soap)	(-30 to +130)	0.85
Petrobras	LUBRAX INDUSTRIAL GMA-2 (Lithium Soap)	(0 to +130)	0.85
Shell	GADUS S3 T100 2 (Diurea Soap)	(-20 to +150)	0.94
SKF	LGHP 2 (Polyurea Soap)	(-40 to +150)	0.94

Table 7.3 shows the most common rolling bearings used in horizontal motors, the quantity of grease and the speed limit for using optional greases.

Table 7.3: Application of alternative greases

Rolling bearing	Grease quantity (g)	Limit speed of the grease [rpm] Horizontal motors				
		GADUS S3 T100 2	LGHP 2	Unirex N3	GADUS S2 V100 3	Lubrax Industrial GMA-2
6220	30	3000	3000	1800	1800	1800
6232	70	1800	1800	1500	1200	1200
6236	85	1500	1500	1200	1200	1200
6240	105	1200	1200	1200	1000	1000
6248	160	1200	1200	1500	900	900
6252	190	1000	1000	900	900	900
6315	30	3000	3000	3000	1800	1800
6316	35	3000	3000	1800	1800	1800
6317	40	3000	3000	1800	1800	1800
6319	45	1800	1800	1800	1800	1800
6320	50	1800	1800	1800	1800	1800
6322	60	1800	1800	1800	1500	1500
6324	75	1800	1800	1800	1500	1500
6326	85	1800	1800	1500	1500	1500
6328	95	1800	1800	1500	1200	1200
6330	105	1500	1500	1500	1200	1200
NU 232	70	1500	1500	1200	1200	1200
NU 236	85	1500	1500	1200	1000	1000
NU 238	95	1200	1200	1200	1000	1000
NU 240	105	1200	1200	1000	900	900
NU 248	160	1000	1000	900	750	750
NU 252	195	1000	1000	750	750	750
NU 322	60	1800	1800	1800	1500	1500
NU 324	75	1800	1800	1500	1200	1200
NU 326	85	1800	1800	1500	1200	1200
NU 328	95	1500	1500	1200	1200	1200
NU 330	105	1500	1500	1200	1000	1000
NU 336	145	1200	1200	1000	900	900

7.9.1.6 Procedure for changing the grease

In order to replace the **POLYREX EM103** grease by one of the alternative greases, the bearings must be opened to remove the old grease and then filled with the new grease.

If it is not possible to open the bearings, the old grease must be purged by applying new grease until it begins to appear in the exit drawer with the motor running.

In order to replace the **PETAMO GHY 133 N** grease by one of the alternative greases, you must first open the bearings, completely remove the old grease, and then fill it with new grease.



ATTENTION

When the bearing is opened, inject the new grease through the grease nipple to expel the old grease found in the grease inlet tube, and apply the new grease in the rolling bearing, to the inner and outer bearing caps, filling 3/4 of the empty spaces. In case of double bearings (ball bearing + roller bearing), also fill 3/4 of the empty spaces between the intermediate rings. Never clean the rolling bearing with cotton-based cloths, because they may release some lint, working as solid particles.



NOTE

WEG is not liable for the grease change or for any damages arising from this change.

7.9.1.7 Low temperature greases

Table 7.4: Grease for application at low temperatures

Manufacturer	Grease	Constant operating temperature (°C)	Application
Exxon Mobil	MOBILITH SHC 100 (Lithium Soap and Synthetic Oil)	(-50 to +150)	Low temperature

7.9.1.8 Grease compatibility

You can say that greases are compatible when the properties of the mixture are within the property ranges of the greases individually.

In general, greases with the same type of soap are compatible; however, depending on the proportion of the mixture, there might be incompatibility. Therefore, it is not recommended to mix different types of grease without consulting the grease supplier or WEG.

Some thickeners and basic oils cannot be mixed, because they do not form a homogeneous mixture. In this case, one cannot rule the possibility of hardening or softening of the grease, or reduction of the dropping point of the resulting mixture.



ATTENTION

Greases with different types of base must never be mixed. For example: Lithium-based greases must never be mixed with sodium or calcium-based greases.

7.9.1.9 Disassembly – horizontal bearings

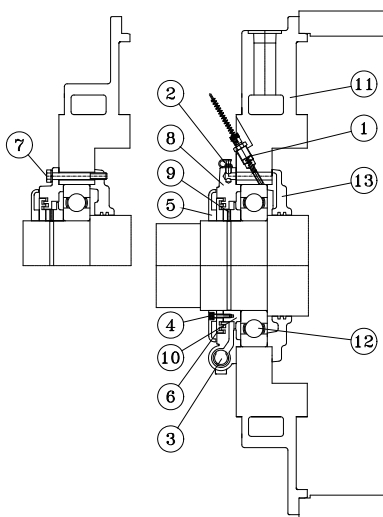

Figure 7.4: DE bearing

Figure 7.4 legend:

1. Temperature sensor
2. Grease nipple
3. Grease collecting drawer
4. Screw
5. Protection disc
6. Labyrinth taconite seal
7. Screw
8. Outer bearing cap
9. Screw
10. Grease flinger
11. ND-end shield
12. Rolling bearing
13. Inner bearing cap

Before disassembling:

- Remove the water from the cooling circuit, as described in section 7.6 of this manual;
- Place the motor in the horizontal position (vertical machines);
- Remove the extension tubes from the grease inlet and outlet;
- Thoroughly clean the external part of the bearing;
- Remove the grounding brush (if any);
- Remove the temperature sensors.

DE bearing disassembly

In order to disassemble the bearing, proceed according to the following guidelines:

1. Remove the screws (4), protection disc (5) and the labyrinth taconite seal (6);
2. Remove the screws (7) from the outer and inner bearing caps (8 and 13);
3. Remove the outer bearing cap (8);
4. Remove the screw (9) that fixes the grease flinger (10);
5. Remove the grease flinger (10);
6. Remove the D-end shield (11);
7. Remove the rolling bearing (12);
8. Remove the inner bearing cap (13) if necessary.

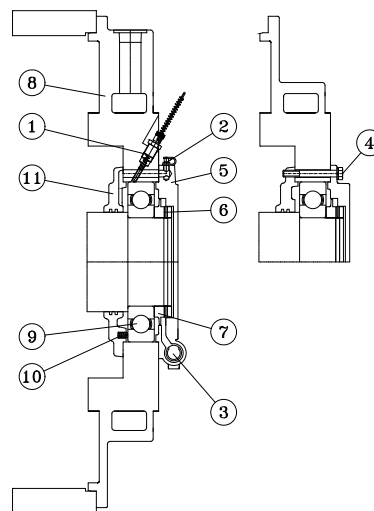

Figure 7.5: NDE bearing

Figure 7.5 legend:

1. Temperature sensor
2. Grease nipple
3. Grease collecting drawer
4. Screw
5. Outer bearing cap
6. Screw
7. Grease flinger
8. ND-end shield
9. Rolling bearing
10. Spring
11. Inner bearing cap

NDE bearing disassembly

In order to disassemble the bearing, proceed according to the following guidelines:

1. Remove the screws (4) from the outer and inner bearing caps (5 and 11);
2. Remove the outer bearing cap (5);
3. Remove the screw (6) that fixes the grease flinger (7);
4. Remove the grease flinger (7);
5. Remove the ND-end shield (8);
6. Remove the rolling bearing (9);
7. Remove the inner bearing cap (11) if necessary.



ATTENTION

- During the bearing disassembly, it is necessary to be careful not to damage the balls, rollers or shaft surface;
- Keep the disassembled parts in a safe and clean place.

7.9.1.10 Disassembly – vertical bearings

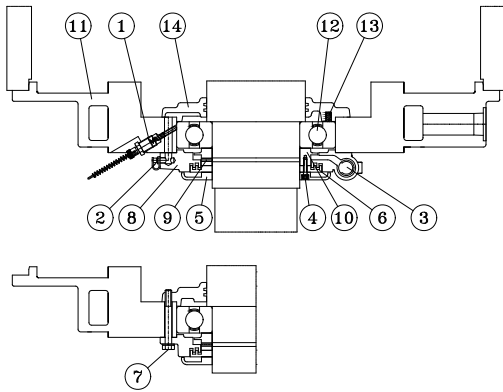

Figure 7.6: Lower bearing

Figure 7.6 legend:

1. Temperature sensor
2. Grease nipple
3. Grease collecting drawer
4. Screw
5. Protection disc
6. Labyrinth taconite seal
7. Screw
8. Outer bearing cap
9. Screw
10. Grease flinger
11. Lower end shield
12. Rolling bearing
13. Spring
14. Inner bearing cap

7.9.1.10.1 Before disassembling

- Remove the water from the cooling circuit, as described in section 7.6 of this manual;
- Remove the extension tubes from the grease inlet and outlet;
- Thoroughly clean the external part of the bearing;
- Remove the grounding brush (if any);
- Remove the temperature sensors.

7.9.1.10.2 Lower bearing disassembly

In order to disassemble the bearing, proceed according to the following guidelines:

1. Place the motor in the horizontal position;
2. Remove the screws (4), protection disc (5) and the labyrinth taconite seal (6);
3. Remove the screws (7) from the outer and inner bearing caps (8 and 14);
4. Remove the outer bearing cap (8);
5. Remove the screw (9) that fixes the grease flinger (10);
6. Remove the grease flinger (10);
7. Remove the lower end shield (11);
8. Remove the rolling bearing (12);
9. Remove the inner bearing cap (14), if necessary.

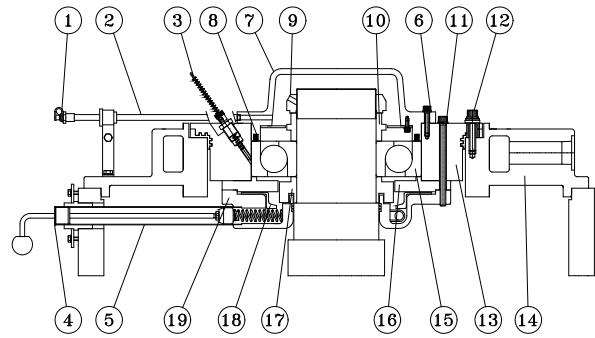

Figure 7.7: Upper bearing

Figure 7.7 legend:

1. Grease nipple
2. Grease inlet tube
3. Temperature sensor
4. Grease collecting drawer
5. Grease outlet tube
6. Screw
7. Outer bearing cap
8. Spring
9. KMT nut
10. Spacer ring
11. Screw
12. Screw
13. Bearing hub
14. Upper end shield
15. Rolling bearing
16. Intermediate ring
17. Grease flinger
18. Guiding ring
19. Inner bearing cap

7.9.1.10.3 Upper bearing disassembly

In order to disassemble the bearing, proceed according to the following guidelines:

1. Support the motor shaft with a hydraulic jack;
2. Remove the screws (6) from the outer bearing cap of the rolling bearing (7);
3. Remove the outer bearing cap (7);
4. Remove the KMT nut (9);
5. Remove the screws (11 and 12) and remove the bearing hub;
6. Remove the upper end shield (14);
7. Move the intermediate ring and the inner bearing cap away from the bearing in order to obtain space to place the device to remove the rolling bearing;
8. Remove the rolling bearing (15);
9. Remove the grease flinger (17), the intermediate ring and the inner bearing cap, if necessary.



ATTENTION

- During the bearing disassembly, it is necessary to be careful not to damage the balls, rollers or shaft surface;
- Keep the disassembled parts in a safe and clean place.

7.9.1.11 Bearing assembly

- Clean the bearings completely and inspect the disassembled parts and the inside of the bearing caps;
- Make sure the rolling bearing, shaft and bearing cap surfaces are perfectly smooth;
- Fill up to $\frac{3}{4}$ of the inner and outer bearing cap deposits with the recommended grease (Figure 7.8) and lubricate the rolling bearing with enough grease before assembling it;
- Before assembling the rolling bearing on the shaft, heat it up to a temperature between 50 °C and 100 °C;
- For the complete assembly of the bearing, follow the disassembly instructions in the reverse order.
- The efficiency of sealing against taconita will be given by the filling of grease between the protrusions of the labyrinth seal and outer ring (if any)

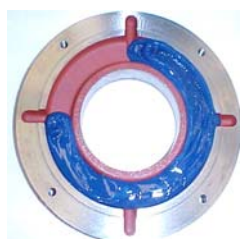

Figure 7.8: Outer bearing cap

7.9.2 Rolling bearing replacement

The disassembly of rolling bearings must be done with an appropriate tool (rolling bearing puller). The arms of the puller must be placed on the lateral surface of the bearing inner ring to be disassembled or on an adjacent part.

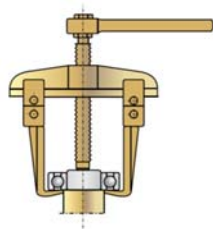

Figure 7.9: Tool for rolling bearing extraction

7.9.3 Bearing protection

7.9.3.1 Protection settings



ATTENTION

The following temperatures must be set on the bearing protection system:
 Alarm 110 °C – Trip 120 °C
 The alarm temperature must be set 10 °C above the operating temperature, not exceeding the limit of 110 °C.

7.9.3.2 Disassembly/assembly of the sleeve bearing temperature sensors

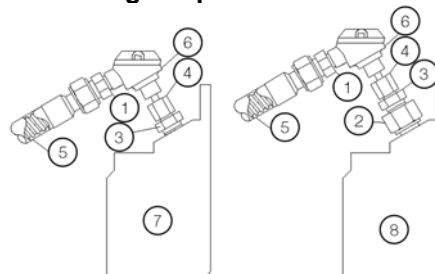

Figure 7.10: Pt100 on the bearings

Figure 7.10 legend:

- 1.Reduction nipple
- 2.Insulating adapter
- 3.Locknut
- 4.Bulb
- 5.Flexible metal tube
- 6.Pt-100 temperature sensor
- 7.Non-insulated bearing
- 8.Insulated bearing

Disassembly instructions:

If it is necessary to remove the Pt100 for bearing maintenance, proceed according to the following instructions:

- Remove the Pt100 carefully, locking the locknut (3), and unscrewing just the Pt100 from the bulb (4);
- Parts (2) and (3) must not be disassembled.

Assembly instructions:



ATTENTION

Before assembling the Pt100 on the bearing, check if it does not contain marks of knock or any other damage that may compromise its operation.

- Insert the Pt100 into the bearing;
- Restrain the locknut (3) with a wrench;
- Screw it in the bulb (4), adjusting it so that the tip of the Pt100 touches the outer surface of the bearing.



NOTES

- The assembly of the Pt100 on non-insulated bearings must be done directly on the bearing, without the insulating adapter (2);
- The tightening torque to assemble the Pt100 and the adapters must not exceed 10Nm.

8 MOTOR DISASSEMBLY AND ASSEMBLY



ATTENTION

All the repair, disassembly and assembly services must be performed only by properly qualified and trained professionals; otherwise, equipment damage and personal injury may occur. If any further explanations are necessary, consult WEG.

The disassembly and assembly sequences depend on the motor model.

Always use proper tools and devices. Any damaged part (cracks, dents on machined parts, faulty threads) must be replaced, avoiding restorations.

8.1 HORIZONTAL MOTORS

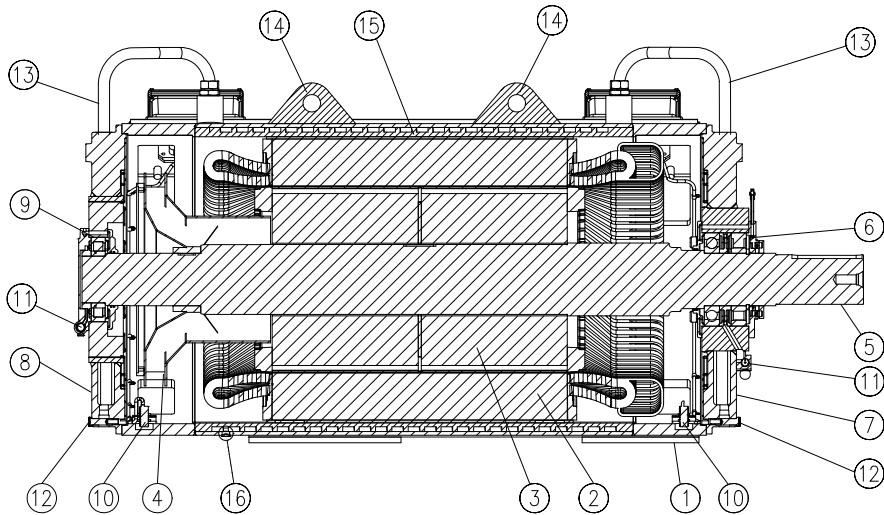

Figure 8.1: Horizontal motor

Figure 8.1: Horizontal motor legend:

1. Feet
2. Stator
3. Rotor
4. Internal fan
5. Shaft
6. DE bearing
7. D-end shield
8. ND-end shield
9. NDE bearing
10. Water leak sensor
11. Grease collecting drawer
12. Drain to remove condensed water
13. Water passage hose
14. Lifting lugs
15. Frame
16. Drain to remove the water from the cooling circuit

8. Disassemble the NDE bearing (9) and the ND-end shield (8);
9. In order to disassemble the bearings, follow the procedures described in the section Bearing disassembly/assembly of this manual;
10. Using a proper device, remove the rotor (3) from the stator (2) by the non-drive end of the motor, taking care not to drag the rotor against the stator laminated core or coil heads.

8.1.2 Assembly

The following precautions must be taken when assembling the motor:

8.1.1 Disassembly

The following precautions must be taken when disassembling the electric motor:

1. Before disassembling the motor, disconnect the pipes of the cooling water supply;
2. Disconnect and remove the water passage hoses (13);
3. Disconnect the motor electrical connections and those of the accessories;
4. Remove the grease nipple extenders and the device to remove the grease from the bearings;
5. Remove the bearing temperature sensors and the grounding brush (if any);
6. In order to prevent damages to the rotor and coil heads, support the shaft on both drive and non-drive ends;
7. Disassemble the DE bearing (6) and the D-end shield (7);

1. Using a proper device, insert the rotor (3) into the stator (2) by the non-drive end of the motor, taking care not to drag the rotor against the stator laminated core or coil heads.
2. Assemble the DE bearing (6) and the D-end shield (7), following the procedure of section 1.1.1.1;
3. Assemble the NDE bearing (9) and the ND-end shield (8), following the procedure described in section 1.1.1.1;
4. Connect the water passage hoses (13);
5. Install the grease nipple extenders and the device to remove the grease from the bearings;
6. Install the bearing temperature sensors and grounding brush (if any);
7. Fill the rolling bearings with the proper amount of grease through the DE and NDE grease nipples.

8.2 VERTICAL MOTORS

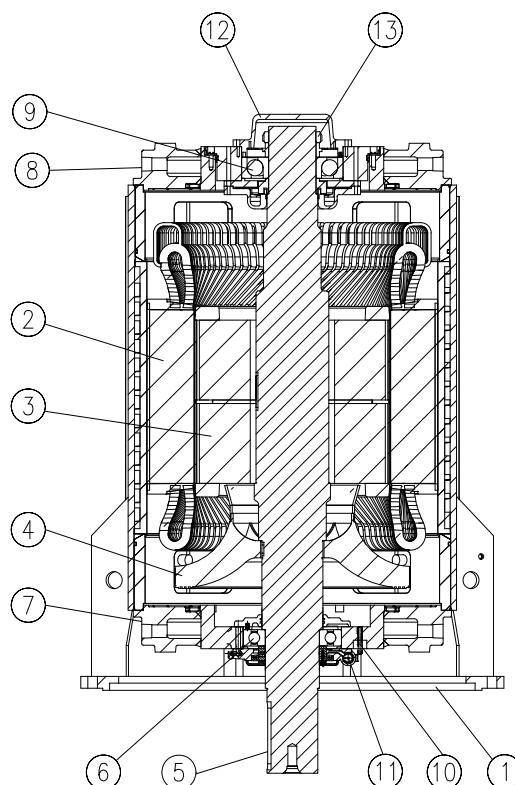

Figure 8.2: Vertical motor

Figure 8.2: Vertical motor legend:

1. Flange
2. Stator
3. Rotor
4. Internal fan
5. Shaft
6. Lower bearing
7. Lower end shield
8. Upper end shield
9. Upper bearing
10. Water leak sensor / drain
11. Grease relief
12. Shaft protection cover
13. Fastening nut of the upper rolling bearing

8.2.1 Disassembly

The following precautions must be taken when disassembling the electric motor:

1. Before disassembling the motor, disconnect the cooling water supply pipes and place the motor in the horizontal position;
2. Disconnect and remove the water passage hoses;
3. Disconnect the motor electrical connections and those of the accessories;
4. Remove the grease nipple extenders and the device to remove the grease from the bearings;
5. Remove the bearing temperature sensors and the grounding brush (if any);
6. In order to prevent damages to the rotor and coil heads, support the shaft on both drive and non-drive ends;
7. Disassemble the lower bearing (6) and the lower end shield (7);
8. Remove the shaft protection cover (12) and the fastening nut of the upper rolling bearing (13);
9. Disassemble the upper bearing (9) and the upper end shield (8);
10. In order to disassemble the bearings, follow the procedures described in the section Bearing disassembly/assembly of this manual;

11. Using a proper device, remove the rotor (3) from the stator (2) by the non-drive end of the motor, taking care not to drag the rotor against the stator laminated core or coil heads.

8.2.2 Assembly

The following precautions must be taken when assembling the motor:

1. Using a proper device, insert the rotor (3) into the stator (2) by the non-drive end of the motor, taking care not to drag the rotor against the stator laminated core or coil heads.
2. Assemble the DE bearing (6) and the D-end shield (7), following the procedure of section 1.1.1.1;
3. Assemble the NDE bearing (9) and the ND-end shield (8), following the procedure described in this manual;
4. Connect the water passage hoses (13);
5. Install the grease nipple extenders and the device to remove the grease from the bearings;
6. Install the bearing temperature sensors and the grounding brush (if any);
7. Fill the rolling bearings with the appropriate amount of grease through the DE and NDE grease nipples

8.3 AIR-GAP MEASUREMENT

After disassembling and assembling the motor, it is necessary to measure the air gap in order to check the concentricity between rotor and stator. Measure the air gap between the metal support of the shaft seal the motors, measure shaft at four shaft equidistant points (45°, 135°, 225° and 315°). The difference between the air gap measurements at two diametrically opposed points should be less than 10% of the average air gap.

ATTENTION

The bearing can only be closed after completion and projected from the air gap

For the single bearing:

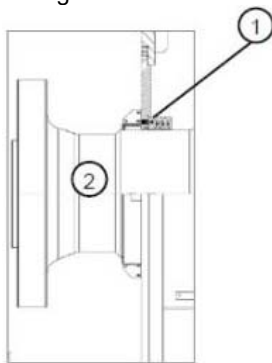

Figure 8.3: DE shaft seal

Legend of Figure 8.3:

1. DE shaft seal
2. Motor shaft

8.4 TIGHTENING TORQUE

The Table 8. and Table 8.2 shows the tightening torques of the screws recommended for assembling the motor.

Table 8.1: Screw tightening torque for metal/metal parts

Material / Resistance class		Carbon Steel / 8.8 or above		Stainless steel / A2 – 70 or above	
% Yield Strength		70%		70%	
Lubricant		Dry	Molycote 1000	Dry	Molycote 1000
Diam	Pitch (mm)	Screws tightening torque (Nm)			
M4	0,7	2,1	1,8	1,8	1,3
M5	0,8	4,2	3,6	3,6	2,7
M6	1	8	6	6,2	4,5
M8	1,25	19,5	15	15	11
M10	1,5	40	29	30	22
M12	1,75	68	51	52	38
M14	2	108	81	84	61
M16	2	168	126	130	94
M18	2,5	240	174	180	130
M20	2,5	340	245	255	184
M22	2,5	470	335	350	251
M24	3	590	424	440	318
M27	3	940	621	700	466
M30	3,5	1170	843	880	632
M33	3,5	1730	1147	1300	860
M36	4	2060	1473	1540	1105
M42	4,5	3300	2359	2470	1770
M48	5	5400	3543	4050	2657

Table 8.2: Screw tightening torque for metal/isolated parts

Material / Resistance class		Carbon Steel / 8.8 or above		Stainless steel / A2 – 70 or above	
% Yield Strength		40%		40%	
Lubricant		Dry	Molycote 1000	Dry	Molycote 1000
Diam	Pitch (mm)	Screws tightening torque (Nm)			
M4	0,7	1	1	1	1,3
M5	0,8	2	2	1,7	2,7
M6	1	4,4	3	3,4	4,5
M8	1,25	10,7	7,5	8,3	11
M10	1,5	21	15	16,5	22
M12	1,75	37	26	28	38
M14	2	60	42	46	61
M16	2	92	65	72	94
M18	2,5	132	90	100	130
M20	2,5	187	126	140	184
M22	2,5	260	172	190	251
M24	3	330	218	240	318
M27	3	510	320	390	466
M30	3,5	640	433	480	632
M33	3,5	950	590	710	860
M36	4	1130	758	840	1105
M42	4,5	1800	1213	1360	1770
M48	5	2970	1822	2230	2657

8.5 SPARE PARTS

When ordering spare parts, please indicate the motor type and serial number as specified on the nameplate. WEG recommends that the following spare parts are kept in stock:

Spare Parts		
• Recommended	▲ Highly recommended	
LA Bearing Temperature Sensor		▲
LOA Bearing Temperature Sensor		▲
Heating resistor		▲
Grounding brush		▲
Lubricant for bearing		▲
Bearing for LA bearing		▲
Bearing for LOA bearing		▲
Teflon seal		▲
Cylindrical pressure spring for LA bearings		▲
Cylindrical pressure spring for LOA bearing		▲
Vibration signal converter for LA bearing (if applicable)	•	
Vibration signal converter for LOA bearing (if applicable)	•	
Temperature sensor for water (if applicable)	•	
Water leakage sensor assembly (if applicable)	•	
Repeater relay for water leakage sensor (if applicable)	•	
Water regulating valve (if applicable)	•	
Inner circlip for LA bearing	•	
Inner circlip for LOA bearing	•	
External circlip for LA bearing	•	
External circlip for LOA bearing	•	
Grease centrifuge for LA bearing	•	
Grease centrifuge for LOA bearing	•	
Ring with labyrinth for bearing LA	•	
Ring with labyrinth for LOA bearing	•	
Protective ring for LA bearing	•	
Protective ring for LOA bearing	•	

Spare parts should be stored in a clean, dry, well-ventilated environment and, if possible, at a constant temperature.

9 MAINTENANCE PLAN

The maintenance plan described in Table 9.1 is only referential, and the intervals between each maintenance intervention may vary according to the motor location and operating conditions.

For the associated equipment, such as the water supply unit or control and protection system, it is necessary to refer to their specific manuals.

Table 9.1: Maintenance plan

MOTOR PART	Weekly	Monthly	3 months	6 months	Annual	3 years	
STATOR							
Visual inspection of the stator.				x			
Cleaning of the stator.						x	
Inspection of the slot wedges.						x	
Verification of the fastening of stator terminals.				x			
Measurement of the winding insulation resistance.				x			
ROTOR							
Visual inspection.				x			
Cleaning of the rotor.						x	
Inspection of the shaft (wear, incrustations).						x	
BEARINGS							
Control of noise, vibration, leaks and temperature.	x						
Lubricant quality control.				x			
Lubricant change.							According to the period indicated on the bearing nameplate.
COOLING SYSTEM							
Verification of the temperature, flow and pressure of the cooling water.	x						
Inspection of the cooling water quality.		x					
Inspection of water pipes and hoses.		x					
Cleaning of the internal channels of the frame and end shields.		x					If there is evidence of change in the water flow, perform the cleaning at shorter intervals.
PROTECTION AND CONTROL EQUIPMENT							
Recording of the values.		x					
Inspection of the operation.		x					
Disassembly and operation test.						x	
COUPLING							
Inspection of the alignment.					x		Check after the first week of operation.
Inspection of the coupling fastening.					x		Check after the first week of operation.
WHOLE MOTOR							
Inspection of the cleanliness, noise and vibration.	x						
Drainage of condensed water.				x			
Retightening of the screws.				x			
Cleaning of the terminal boxes.				x			
Retightening of electrical and grounding connections.				x			

10 ABNORMALITIES, CAUSES AND SOLUTIONS



NOTE

The instructions of Table 10.1 present only a basic list of abnormalities, causes and corrective actions. In case of questions, consult WEG.

Table 10.1: Basic list of abnormalities, causes and corrective actions

ABNORMALITY	POSSIBLE CAUSES	CORRECTION
Neither coupled nor uncoupled does the motor start	▪ At least two power cables are interrupted, without voltage	▪ Check the control panel, the power cables and the terminals
	▪ Rotor is locked	▪ Unlock the rotor
	▪ Damaged bearing	▪ Replace the bearing
Motor starts with no load, but fails when load is applied. It starts very slowly and does not reach the rated speed	▪ Load torque is too high during the start.	▪ Do not apply load to the driven machine during the start
	▪ Power supply voltage is too low	▪ Measure the power supply voltage and set it to the correct value.
	▪ Very high voltage drop in the power cables	▪ Check the sizing of the installation (transformer, cable section, relays, circuit breakers, etc.)
	▪ Rotor with faulty or interrupted bars	▪ Check and repair the rotor winding
The stator current oscillates under load with double the slip frequency. The motor presents a humming noise during starting	▪ A power cable was interrupted after the start	▪ Check the power cables
	▪ Rotor winding is interrupted	▪ Check and repair the rotor winding
Very high no load current	▪ Power supply voltage is too high	▪ Measure the power supply voltage and set it to the correct value
Hot spots in the stator winding.	▪ Short-circuit between turns	▪ Rewind the stator
	▪ Interruption of parallel wires or phases of the stator winding	▪ Redo the connection of the stator cables
	▪ Faulty connection	▪ Redo the connection
Hot spots in the rotor.	▪ Interruptions in the rotor bars	▪ Repair the rotor or replace it
Abnormal noise during operation with load.	▪ Mechanical causes	▪ The noise normally decreases when the speed reduces; see also: “noisy operation when uncoupled”
	▪ Electrical causes	▪ The noise disappears when the motor is switched off. Contact the manufacturer
When coupled, there is noise; when uncoupled, the noise disappears	▪ Defect in the coupling parts or in the driven machine	▪ Check the power transmission, the coupling and the alignment
	▪ Defect in the gear coupling	▪ Align the driving set
	▪ Unaligned/unleveled base	▪ Align/level the motor and the driven machine
	▪ Faulty balancing of the components or of the driven machine	▪ Perform new balancing
	▪ Defective coupling	▪ Repair the coupling
	▪ Wrong rotation direction of the motor	▪ Invert the connection of two phases

ABNORMALITY	POSSIBLE CAUSES	CORRECTION
Stator winding becomes very hot under load	<ul style="list-style-type: none"> ▪ Insufficient cooling due to dirty water channels 	<ul style="list-style-type: none"> ▪ Clean the water passage channels
	<ul style="list-style-type: none"> ▪ Overload 	<ul style="list-style-type: none"> ▪ Measure the stator current. Reduce the load. Analyze the motor application
	<ul style="list-style-type: none"> ▪ High number of starts or moment of inertia too high 	<ul style="list-style-type: none"> ▪ Reduce the number of starts
	<ul style="list-style-type: none"> ▪ Voltage too high, therefore, the iron losses increase 	<ul style="list-style-type: none"> ▪ Do not exceed 110% of the rated voltage, except when otherwise specified on the nameplate
	<ul style="list-style-type: none"> ▪ Voltage too low, therefore, the current is very high 	<ul style="list-style-type: none"> ▪ Check the supply voltage and the voltage drop on the motor
	<ul style="list-style-type: none"> ▪ Interruption in a power cable or in a winding phase 	<ul style="list-style-type: none"> ▪ Measure the current in all the phases and, if necessary, correct it
	<ul style="list-style-type: none"> ▪ Rotor drags against the stator 	<ul style="list-style-type: none"> ▪ Check the air-gap, operating conditions (vibration etc.), bearing conditions
	<ul style="list-style-type: none"> ▪ The operating condition does not correspond to the nameplate data 	<ul style="list-style-type: none"> ▪ Keep the operating condition according to the nameplate or reduce the load
	<ul style="list-style-type: none"> ▪ Unbalance in the power supply (blown fuse, wrong command) 	<ul style="list-style-type: none"> ▪ Check if there is voltage unbalance or operation with two phases and correct it
	<ul style="list-style-type: none"> ▪ Dirty windings 	<ul style="list-style-type: none"> ▪ Clean the windings
<ul style="list-style-type: none"> ▪ Rotation direction is not compatible with the used fan 	<ul style="list-style-type: none"> ▪ Check the fan regarding to the motor rotation direction 	
Noisy operation when uncoupled	<ul style="list-style-type: none"> ▪ Unbalance 	<ul style="list-style-type: none"> ▪ Perform new balancing
	<ul style="list-style-type: none"> ▪ Interruption in one phase of the stator winding 	<ul style="list-style-type: none"> ▪ Measure the current of all connecting cables
	<ul style="list-style-type: none"> ▪ Fastening screws are loose 	<ul style="list-style-type: none"> ▪ Retighten and lock the screws
	<ul style="list-style-type: none"> ▪ The rotor balancing conditions become worse after the assembly of the coupling 	<ul style="list-style-type: none"> ▪ Balance the coupling
	<ul style="list-style-type: none"> ▪ Resonance in the foundation 	<ul style="list-style-type: none"> ▪ Adjust the foundation
	<ul style="list-style-type: none"> ▪ Motor frame deformed 	<ul style="list-style-type: none"> ▪ Check flatness of the base
	<ul style="list-style-type: none"> ▪ Bent shaft 	<ul style="list-style-type: none"> ▪ Check the rotor balancing and eccentricity
	<ul style="list-style-type: none"> ▪ Air-gap is not even 	<ul style="list-style-type: none"> ▪ Check shaft warping or rolling bearing wear

11 DECLARATION OF CONFORMITY

EU Declaration of Conformity

**Manufacturers:**

WEG Equipamentos Elétricos S.A.
Av. Prefeito Waldemar Grubba, 3000
89256-900 - Jaraguá do Sul – SC – Brazil
www.weg.net

WEG Industrie (India) PVT. LTD.
Plot n° E-20 (North), SIPCOT Industrial Complex
Phase II – Expansion II.
Mornapalli Village, Hosur 635 109
Tamil Nadu - India
www.weg.net/in

WEG MEXICO, S.A. DE C.V
Carretera Jorobas - Tula Km 3.5, Manzana 5,
Lote 1, Fraccionamiento Parque Industrial Huehuetoca,
Municipio de Huehuetoca, C.P. 54680,
CD. de Mexico y Área Metropolitana – Mexico
www.weg.net/mx

WEG (Nantong) Electric Motor Manufacturing CO., LTD.
No. 128# - Xinkai South Road, Nantong
Economic & Technical Development
Zone, Nantong, Jiangsu Province – China
www.weg.net/cn

WEGeuro – Industria Eléctrica S.A.
Rua Eng Frederico Ulrich,
4470-605 – Maia – Porto – Portugal
www.weg.net/pt
Contact person: Luís Filipe Oliveira Silva Castro Araújo
Authorised Representative in the European Union
(Single Contact Point)

The manufacturer declares under sole responsibility that:

WEG synchronous and asynchronous motors, WEG generators and their components used for following lines:

M..., W60, WGM, G...S and AN10

.....

when installed, maintained and used in applications for which they were designed, and in compliance with the relevant installation standards and manufacturer's instructions, comply with the provisions of the following relevant European Union harmonization legislation, wherever applicable:

Low Voltage Directive 2014/35/EU*
Machinery Directive 2006/42/EC**

EMC Directive 2014/30/EU (electric motors are considered inherently benign in terms of electromagnetic compatibility)

The fulfilment of the safety objectives of the relevant European Union harmonisation legislation has been demonstrated by compliance with the following standards, wherever applicable:

**EN 60034-1:2010 + AC:2010/ EN 60034-3:2008 / EN 60034-5:2001 + A1:2007/ EN 60034-6:1993/
EN 60034-7:1993 + A1:2001/ EN 60034-8:2007 + A1: 2014/ EN 60034-9:2005 + A1:2007/
EN 60034-11:2004/ EN 60034-12:2002 + A1:2007/ EN 60034-14:2004 + A1:2007/
EN 60204-1:2018 and EN IEC 60204-11:2019**

CE marking in: **1998**

* Electric motors designed for use with a voltage rating higher than 1000V are not considered under the scope.

** Low voltage electric motors are not considered under the scope and electric motors designed for use with a voltage rating higher than 1000V are considered partly completed machinery and are supplied with a

Declaration of Incorporation:

The products above cannot be put into service until the machinery into which they have been incorporated has been declared in conformity with the Machinery Directive.

A Technical Documentation for the products above is compiled in accordance with part B of annex VII of Machinery Directive 2006/42/EC.

We undertake to transmit, in response to a reasoned request by the national authorities, relevant information on the partly completed machinery identified above through WEG authorised representative established in the European Union. The method of transmission shall be electronic or physical method and shall be without prejudice to the intellectual property rights of the manufacturer.

Signed for and on behalf of the manufacturer:
Rodrigo Fumo Fernandes
Engineering director

Jaraquá do Sul, April 14th, 2022

DEC3222-Rev00 - English 1/1

12 ENVIRONMENTAL INFORMATION

12.1 PACKAGE

Electric motors are supplied in cardboard, polymer, wood or metallic material packages. These materials are recyclable or reusable and must be properly disposed according to the current regulations of each country. All the wood used in the packaging of WEG motors comes from reforestation and receives anti-fungal treatment.

12.2 PRODUCT

Electric motors, under the constructive aspect, are manufactured mainly with ferrous metals (steel, cast iron), nonferrous metals (copper, aluminum) and plastic. The electric motor, in general, is a product that has a long useful life; however, when it must be disposed, WEG recommends that the materials of the packaging and of the product be properly separated and sent for recycling.

The non-recyclable materials must be properly disposed according to the environmental regulations, i.e., in industrial landfills, co-processed in cement kilns or incinerated. The service providers for recycling, disposal in industrial landfills, co-processing or incineration of waste must be properly licensed by the environmental agency of each state to carry out these activities.

12.3 HAZARDOUS WASTE

Grease and oil waste used to lubricate the bearings should be disposed, according to the instructions of the relevant environmental agencies, because its improper disposal can cause impacts to the environment.

13 SERVICE NETWORK

To consult the Service Network, access the website www.weg.net.

14 WARRANTY TERM

These products, when operated under the conditions stipulated by WEG in the operating manual for such product, are warranted against defects in workmanship and materials for twelve (12) months from start-up date or eighteen (18) months from manufacturer shipment date, whichever occurs first.

However, this warranty does not apply to any product which has been subject to misuse, misapplication, neglect (including without limitation, inadequate maintenance, accident, improper installation, modification, adjustment, repair or any other cases originated from inadequate applications).

The company will neither be responsible for any expenses incurred in installation, removal from service, consequential expenses such as financial losses nor transportation costs as well as tickets and accommodation expenses of a technician when this is requested by the customer.

The repair and/or replacement of parts or components, when effected by WEG within the Warranty period do not give Warranty extension, unless otherwise expressed in writing by WEG.

This constitutes WEG's only warranty in connection with this sale and is in lieu of all other warranties, expressed or implied, written or oral.

There are no implied warranties of merchantability or fitness for a particular purpose that apply to this sale.

No employee, agent, dealer, repair shop or other person is authorized to give any warranties on behalf of WEG nor to assume for WEG any other liability in connection with any of its products.

In case this happens without WEG's authorization, Warranty is automatically cancelled.

LIABILITY

Except as specified in the foregoing paragraph entitled "Warranty Terms for Engineering Products", the company shall have no obligation or liability whatsoever to the purchaser, including, without limitation, any claims for consequential damages or labor costs, by reason of any breach of the express warranty described therein.

The purchaser further hereby agrees to indemnify and hold the company harmless from any causes of action (other than cost of replacing or repairing the defective product as specified in the foregoing paragraph entitled "Warranty Terms for Engineering Products"), arising directly or indirectly from the acts, omissions or negligence of the purchaser in connection with or arising out of the testing, use, operation, replacement or repair of any product described in this quotation and sold or furnished by the company to the purchaser.



WEG Group - Energy Business Unit
Jaraguá do Sul - SC - Brazil
Phone: 55 (47) 3276-4000
energia@weg.net
www.weg.net



+55 47 3276.4000



energia@weg.net



Jaraguá do Sul - SC - Brazil