

Industrial Motors
Commercial &
Appliance Motors
Automation
Digital &
Systems
Energy
Transmission &
Distribution
Coatings

VBWB - Withdrawable Vacuum Circuit Breaker

Reliability and
robustness for
your needs



Driving efficiency and sustainability





S U M M A R Y

Introduction

04

Benefits

05

Main characteristics

06

Technical data

06

Construction characteristics

07

Coding

08

Accessories

09

Wiring diagram

16

Dimensions

22

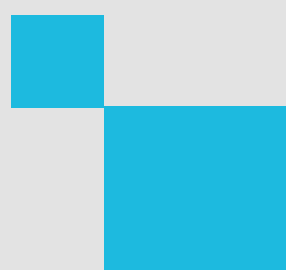





Reliability and robustness

for your needs

The VBWB withdrawable vacuum circuit breaker has a sturdy and compact structure for electrical circuit protection cubicles that require reliability and robustness. Due to its extraction system, the user can conduct scheduled inspections, maintenance and exchanges, minimizing the risks of compromising the delivery of electrical energy to its customers.

The circuit breaker has electrical contacts inside vacuum interrupter, embedded in an epoxy resin pole that guarantees the interruption of the electric current during a short circuit, extinguishing the electric arc inside the bottle.

The embedded pole reduces the energy generated by the electric arc, thus extending the service life of the electrical contact.



Benefits



Complete range of accessories



Easy accessory assembly and product setup



Compliance with severe protection requirements for electrical circuits



Embedded poles that reduce electric arc and ensure extended service life

Main characteristics

Vacuum interrupter

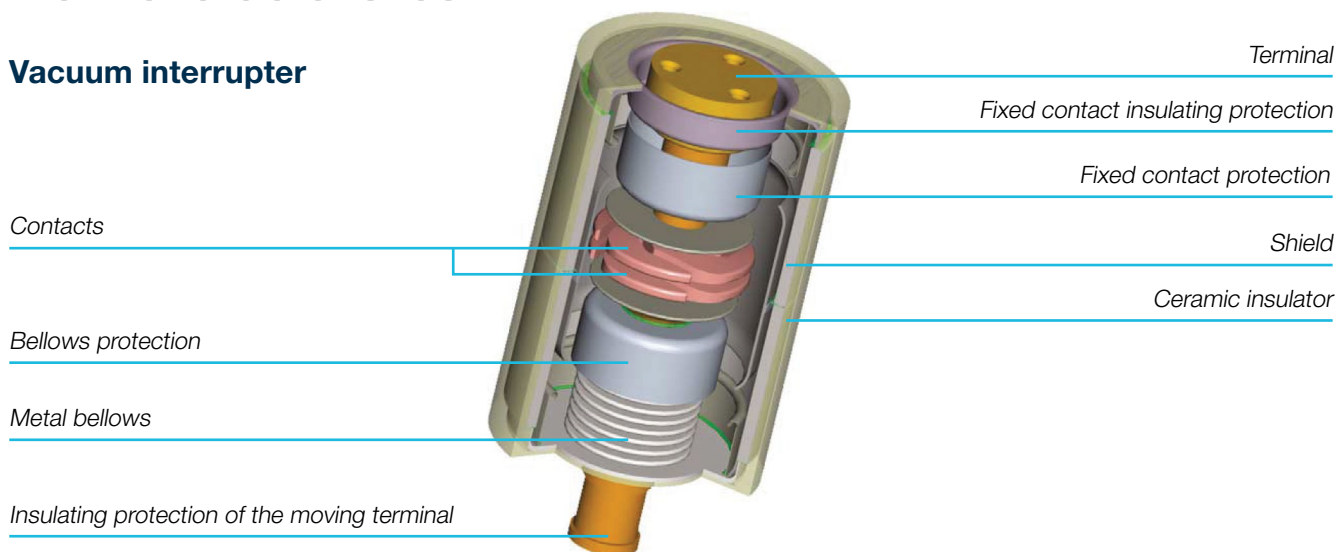

The VBWB line with Withdrawable Mechanism offers two models, with currents of 1,250 and 2,500 A.



Ur (kV)	Isc (kA)	Ir (A)
17.5	25	1,250
17.5	31.5	1,250
17.5	31.5	2,500

Technical data

Standard	IEC 62271-100			
		3P	3P	3P
Poles		3P	3P	3P
Rated voltage	Ur [kV]	17.5	17.5	17.5
Rated insulation voltage	Us [kV]	17.5	17.5	17.5
Withstand voltage	Ud (1min) [kV]	38	38	38
Impulse withstand voltage	Up [kV]	95	95	95
Rated frequency	fr [Hz]	50 / 60 Hz	50 / 60 Hz	50 / 60 Hz
Rated normal current (40°C)	Ir [A]	1,250	1,250	2,500
Rated breaking capacity (rated short-circuit breaking current symmetrical)	Isc [kA]	25	31.5	31.5
Rated short-time withstand current (3s)	Ik [kA]	25	31.5	31.5
Making capacity (50Hz)	Ip [kA]	63	79	79
Making capacity (60Hz)	Ip [kA]	65	82	82
Making capacity considering Isc		2.5 x Isc (50Hz) 2.6 x Isc (60Hz)	2.5 x Isc (50Hz) 2.6 x Isc (60Hz)	2.5 x Isc (50Hz) 2.6 x Isc (60Hz)
Operation sequence		0 - 0.3s - CO - 15s - CO	0 - 0.3s - CO - 15s - CO	0 - 0.3s - CO - 15s - CO
Electric Contacts		10 NA + 10 NF	10 NA + 10 NF	10 NA + 10 NF
Maximum switching quantity without load	Cicles	10,000	10,000	10,000
Mechanical switching class		M2	M2	M2
Electrical switching class		E2	E2	E2
Operating switching class		S1	S1	S1
Capacitive switching class		C2	C2	C2
Opening time	[ms]	≤60	≤60	≤60
Closing time	[ms]	≤70	≤70	≤70
Arching time	[ms]	10 - 15	10 - 15	10 - 15
Total breaking time	[ms]	≤75	≤75	≤75
Weight	[kg]	104	104	188
High		H [mm]	621.5	690
Width		W [mm]	502	853
Deep		D [mm]	665	641
Distance between poles		P [mm]	150	275
Operating temperature		[°C]	-5...+40	-5...+40

Construction characteristics

VBWB-F

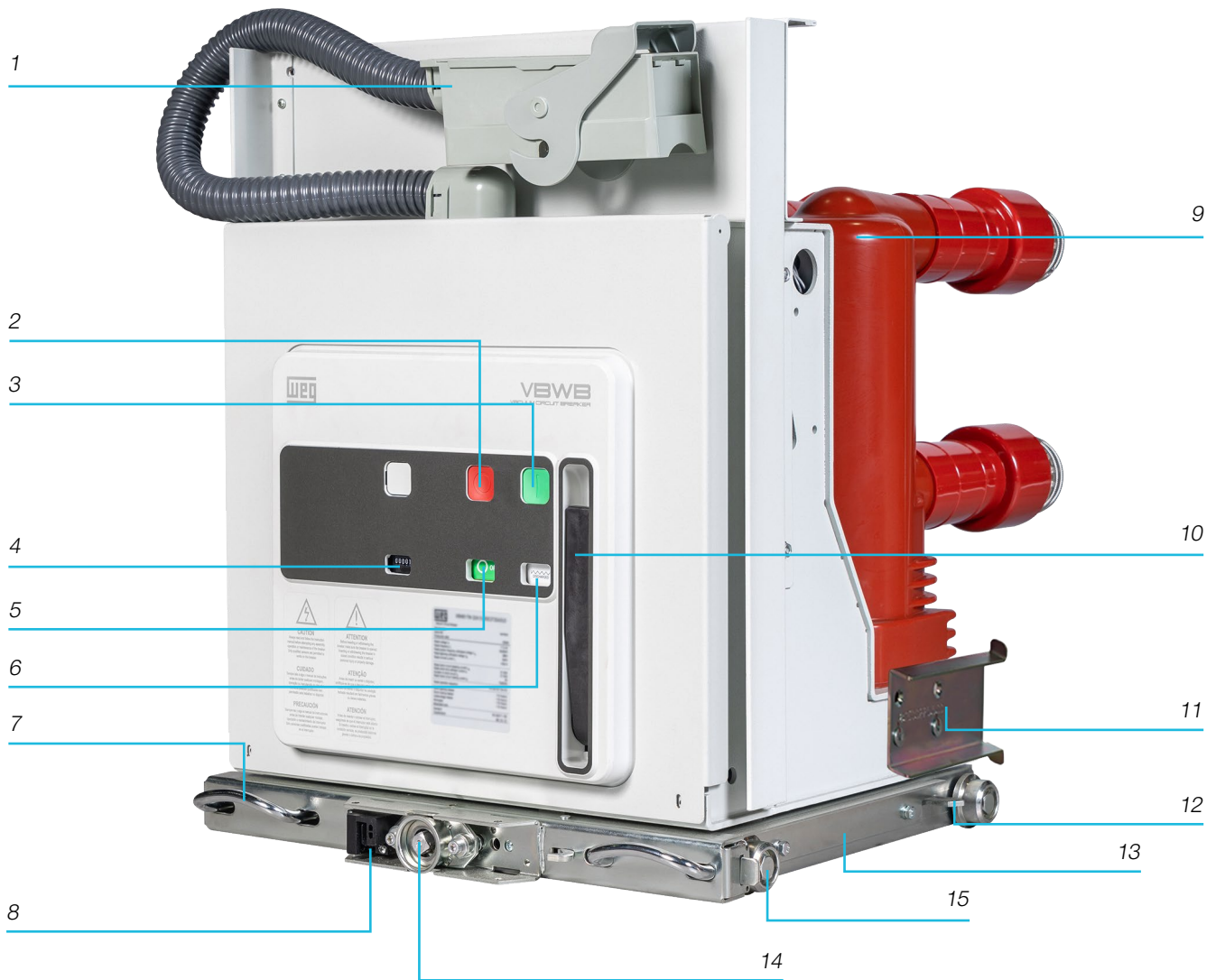

- | | |
|--|---|
| <ol style="list-style-type: none"> 1. Control power connector 2. Opening pushbutton 3. Closing pushbutton 4. Mechanical operation counter 5. Circuit breaker open/closed mechanical indicator 6. Operation spring charged/discharged mechanical indicator 7. Insertion/extraction handles on the panel 8. Interlock between circuit breaker and circuit breaker compartment door | <ol style="list-style-type: none"> 9. Embedded pole 10. Spring loading lever 11. Device for activating the shutters of the circuit breaker electric panel enclosure 12. Grounding switch interlocking device 13. Truck 14. Truck drive spindle (insertion/extraction) 15. Panel fixing latches |
|--|---|

Coding

VCB VBWB

F 17 12 31-15 WO-M1 C1 O1

Pole position	Code
Front	F

Rated voltage	Code
17.5 kV	17

Rated current	Code
1,250 A	12
2,500 A	25

Rated breaking capacity	Code
25 kA	25 ¹⁾
31.5 kA	31

Poles distance ⁵⁾	Code
150 mm	15
275 mm	27

Type	Code
Withdrawable	W0
Withdrawable with motor 125 V _{DC}	W1

Spring charging motor	Code
Without	M0
100 - 130 V _{AC/DC}	M1
200 - 250 V _{AC/DC}	M2
24 V _{DC}	M3

Accessories	Code
Without	
Key block	K
Individual paddlock for pushbuttons	I
Simultaneous paddlock for pushbuttons	S

Mechanical locking coil ⁴⁾	Code
Without	
100 - 130 V _{AC/DC}	L1
200 - 250 V _{AC/DC}	L2
24 V _{DC}	L3

Undervoltage release ^{2,3)}	Code
Without	
100 - 130 V _{AC/DC}	U1
200 - 250 V _{AC/DC}	U2
24 V _{DC}	U3

Additional shunt opening ²⁾	Code
Without	
100 - 130 V _{AC/DC}	S1
200 - 250 V _{AC/DC}	S2
24 V _{DC}	S3

Shunt opening release	Code
Without	O0
100 - 130 V _{AC/DC}	O1
200 - 250 V _{AC/DC}	O2
24 V _{DC}	O3

Shunt closing release	Code
Without	C0
100 - 130 V _{AC/DC}	C1
200 - 250 V _{AC/DC}	C2
24 V _{DC}	C3

Standard accessories	Operation counter
	Truck position contact
	Mechanical interlock with door
	Mechanical interlock between VBWB and truck
	Auxiliary contacts of the truck (1NO+1NC+2NOC)
	With antipumping system

- Notes: 1) Available only in the W0 version.
 2) It is not possible to install undervoltage release and additional shunt opening. It must be selected undervoltage or additional shunt opening coil.
 3) Undervoltage release must be actuated all the time for keeping the VCB operating.
 4) The mechanical locking coil must be energized for closing the VCB.
 5) Code 15 is for VBWB of 1,250 A and code 27 is for VBWB of 2,500 A.

Accessories

The VBWB circuit breaker has a complete line of accessories to guarantee a complete solution for industrial applications.

Motor-operated truck for insertion and extraction of the circuit breaker (-MAT)

- It allows the remote insertion and extraction of the circuit breaker into the electrical panel.
- Product code W0 is for the car with manual extraction.
- Product code W1 is for the motorized car with a operating voltage of 125 Vdc.

Characteristics		Specification
Reference		Motor-operated truck E-10
Supply voltage	(Vn)	125 Vdc
Inrush current	(A)	3.5
Rated output power		180 W
Duty cycle		S2 (1min)
Operating voltage		85 - 110%

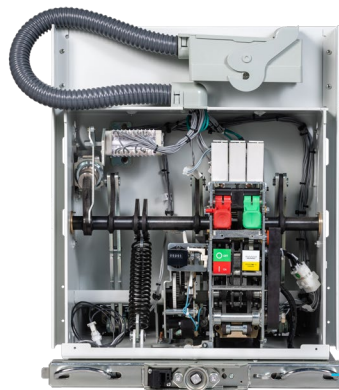

Truck - manual or motor-operated version

Note: illustrative drawings.

Accessories

Geared motor for loading closing spring (-MAS)

- The geared motor charges the spring that close the circuit breaker.
- The spring is automatically charged after the circuit breaker closes.
- When necessary, it allows manually charging the spring using the spring loading lever.

Characteristics	Specification		
Reference	VBWB-AM C03	VBWB-AM D13	VBWB-AM D23
Code	17175264	17175261	17175260
Supply voltage (Vn)	24 V _{dc}	100 - 130 V _{AC} / V _{dc}	200 - 250 V _{AC} / V _{dc}
Rated current (A)	6.5	1.4	0.7
Rated output power	V _{dc} = 40 W; V _{AC} = 40 VA	V _{dc} = 40 W; V _{AC} = 40 VA	V _{dc} = 40 W; V _{AC} = 40 VA
Rated rotational speed	8 rpm	8 rpm	8 rpm
Rated torque	50 Nm	50 Nm	50 Nm
Charging time	6 - 7s	6 - 7s	6 - 7s
Duty cycle	S2 (1min)	S2 (1min)	S2 (1min)
Operating voltage	85 - 110%	85 - 110%	85 - 110%

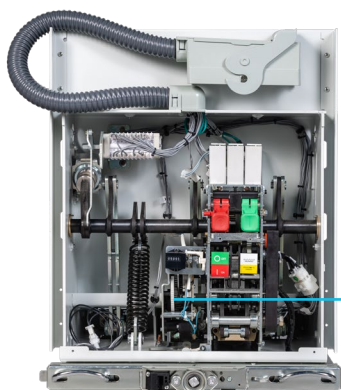

Geared motor for loading closing spring (-MAS)

Shunt closing release (-MBC)

- It allows closing the circuit breaker by an electrical command (the springs must be previously charged).
- The electrical pulse must be greater than 200 ms for closing the VBWB.

Characteristics	Specification		
Reference	MBC VBWB C03	MBC VBWB E56	MBC VBWB E57
Code	16119643	16119644	16119646
Supply voltage (Vn)	24 V _{dc}	100 - 130 V _{AC} / V _{dc}	200 - 250 V _{AC} / V _{dc}
Operating voltage	85 - 110% V _{AC}	85 - 110% V _{AC}	85 - 110% V _{AC}
	70 - 110% V _{dc}	70 - 110% V _{dc}	70 - 110% V _{dc}
Consumption	Inrush power V _{dc} = 300 W / V _{AC} = 300 VA	V _{dc} = 400 W / V _{AC} = 400 VA	V _{dc} = 500 W / V _{AC} = 500 VA
	Continuous power V _{dc} = 2 W / V _{AC} = 2 VA	V _{dc} = 2 W / V _{AC} = 2 VA	V _{dc} = 2 W / V _{AC} = 2 VA
Opening time	≤ 50 ms	≤ 50 ms	≤ 50 ms
Closing time	≤ 70 ms	≤ 70 ms	≤ 70 ms
Insulation voltage	2000 V 50/60 Hz (1 min)	2000 V 50/60 Hz (1 min)	2000 V 50/60 Hz (1 min)



Shunt closing release

Note: illustrative drawings.

Accessories

Shunt opening release (-MB01)

- It allows opening the circuit breaker by an electrical command.
- The electrical pulse must be greater than 35 ms for open the VBWB.

Characteristics		Specification		
Reference		MB01 VBWB C03	MB01 VBWB E56	MB01 VBWB E57
Code		16119584	16119585	15830558
Supply voltage	(Vn)	24 V _{DC}	100 - 130 V _{AC} / V _{DC}	200 - 250 V _{AC} / V _{DC}
Operating voltage		85 - 110% V _{AC}	85 - 110% V _{AC}	85 - 110% V _{AC}
		70 - 110% V _{DC}	70 - 110% V _{DC}	70 - 110% V _{DC}
Consumption	Inrush power	V _{DC} = 300 W / V _{AC} = 300 VA	V _{DC} = 400 W / V _{AC} = 400 VA	V _{DC} = 500 W / V _{AC} = 500 VA
	Continuous power	V _{DC} = 2 W / V _{AC} = 2 VA	V _{DC} = 2 W / V _{AC} = 2 VA	V _{DC} = 2 W / V _{AC} = 2 VA
Opening time		≤ 50 ms	≤ 50 ms	≤ 50 ms
Closing time		≤ 70 ms	≤ 70 ms	≤ 70 ms
Insulation voltage		2000 V 50/60 Hz (1 min)	2000 V 50/60 Hz (1 min)	2000 V 50/60 Hz (1 min)

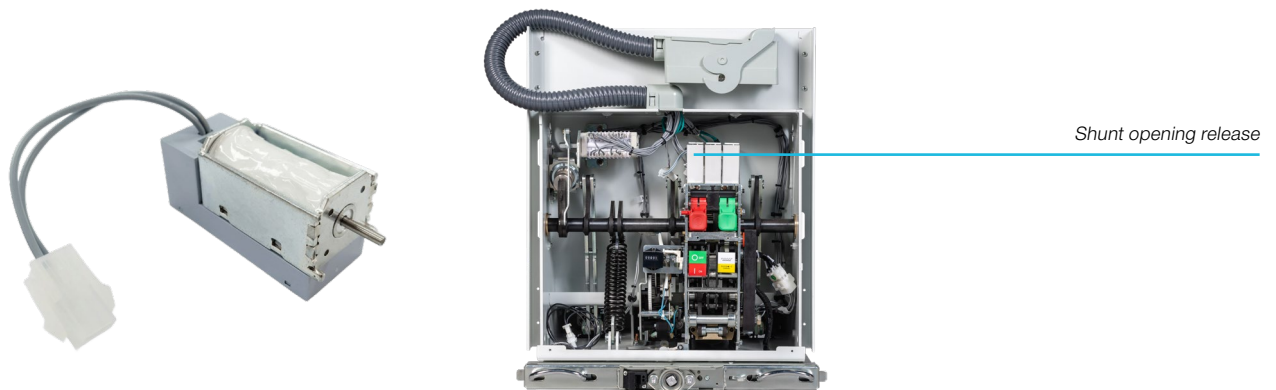

Additional shunt opening release (-MB02)

- It allows opening the circuit breaker by an electrical command.
- The electrical pulse must be greater than 35 ms for open the VBWB.

Characteristics		Specification		
Reference		MB02 VBWB C03	MB02 VBWB E56	MB02 VBWB E57
Code		16119586	16119587	16119638
Supply voltage	(Vn)	24 V _{DC}	100 - 130 V _{AC} / V _{DC}	200 - 250 V _{AC} / V _{DC}
Operating voltage		85 - 110% V _{AC}	85 - 110% V _{AC}	85 - 110% V _{AC}
		70 - 110% V _{DC}	70 - 110% V _{DC}	70 - 110% V _{DC}
Consumption	Inrush power	V _{DC} = 300 W / V _{AC} = 300 VA	V _{DC} = 400 W / V _{AC} = 400 VA	V _{DC} = 500 W / V _{AC} = 500 VA
	Continuous power	V _{DC} = 2 W / V _{AC} = 2 VA	V _{DC} = 2 W / V _{AC} = 2 VA	V _{DC} = 2 W / V _{AC} = 2 VA
Opening time		≤ 50 ms	≤ 50 ms	≤ 50 ms
Closing time		≤ 70 ms	≤ 70 ms	≤ 70 ms
Insulation voltage		2000 V 50/60 Hz (1 min)	2000 V 50/60 Hz (1 min)	2000 V 50/60 Hz (1 min)

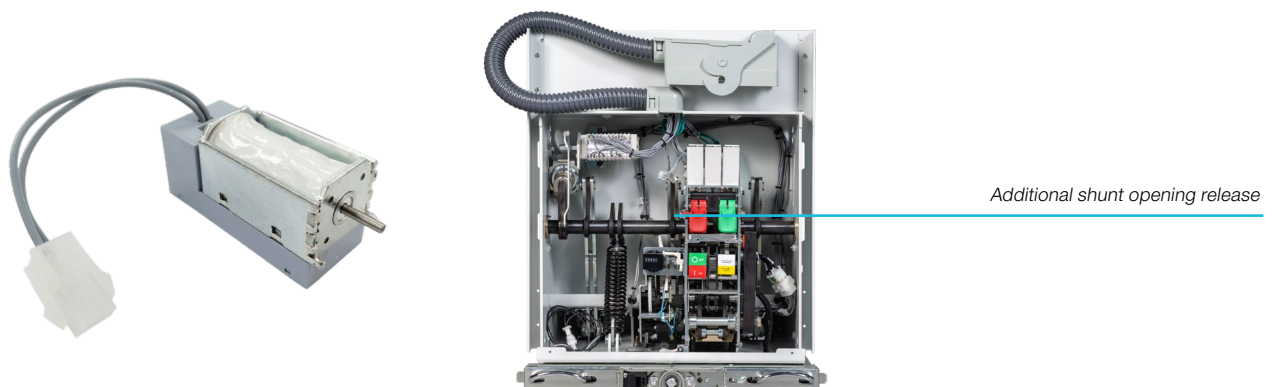

Note: illustrative drawings.

Accessories

Shunt undervoltage release (-MBU)

- It requires constant power to maintain the circuit breaker in the closed position and to trigger a trip in the event of a voltage drop or control power failure.

Characteristics	Specification		
Reference	MBU VBWB C03	MBU VBWB E56	MBU VBWB E57
Code	16119647	16119678	16119679
Supply voltage (Vn)	24 V _{DC}	100 - 130 V _{AC} / V _{DC}	200 - 250 V _{AC} / V _{DC}
Consumption	Inrush power	V _{DC} = 600 W / V _{AC} = 600 VA	V _{DC} = 1200 W / V _{AC} = 1200 VA
	Continuous power	V _{DC} = 5 W / V _{AC} = 5 VA	V _{DC} = 5 W / V _{AC} = 5 VA
Operating voltage range (closing the circuit breaker)	85 - 110%	85 - 110%	85 - 110%
Dropout voltage range (opening the circuit breaker)	35 - 70%	35 - 70%	35 - 70%
Opening time	≤ 70 ms	≤ 70 ms	≤ 70 ms
Insulation voltage	2000 V 50/60 Hz (1 min)	2000 V 50/60 Hz (1 min)	2000 V 50/60 Hz (1 min)

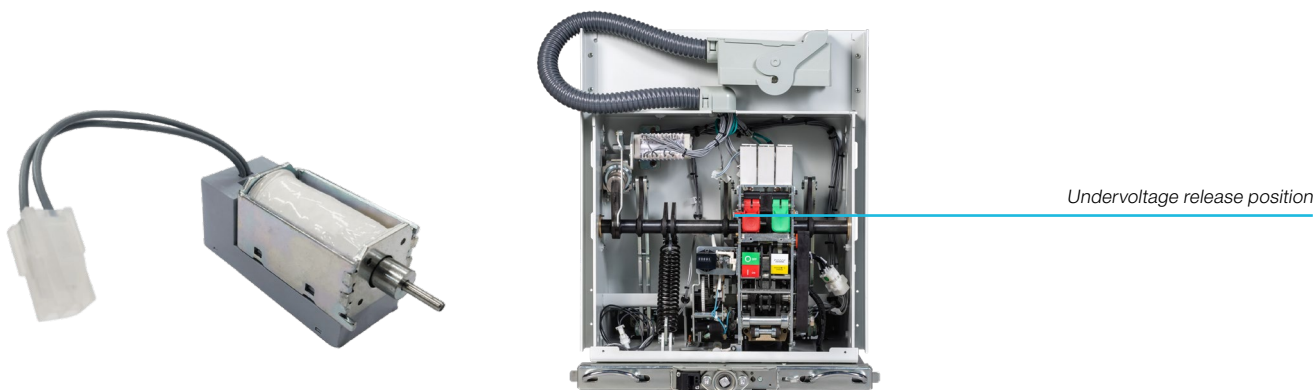

Locking magnet on the operating mechanism (-RLE1)

- Requires power to enable breaker closing.
- It can be de-energized once closed.
- Re-energization required for subsequent closing.

Characteristics	Specification		
Reference	RLE1 VBWB C03	RLE1 VBWB E56	RLE1 VBWB E57
Code	16119685	16119686	16119698
Supply voltage (Vn)	24 V _{DC}	100 - 130 V _{AC} / V _{DC}	200 - 250 V _{AC} / V _{DC}
Consumption	Inrush power	V _{DC} = 600 W / V _{AC} = 600 VA	V _{DC} = 1200 W / V _{AC} = 1200 VA
	Continuous power	V _{DC} = 5 W / V _{AC} = 5 VA	V _{DC} = 5 W / V _{AC} = 5 VA
Operating voltage range (closing the circuit breaker)	85 - 110%	85 - 110%	85 - 110%
Dropout voltage range (opening the circuit breaker)	35 - 70%	35 - 70%	35 - 70%
Opening time	≤ 70 ms	≤ 70 ms	≤ 70 ms
Insulation voltage	2000 V 50/60 Hz (1 min)	2000 V 50/60 Hz (1 min)	2000 V 50/60 Hz (1 min)

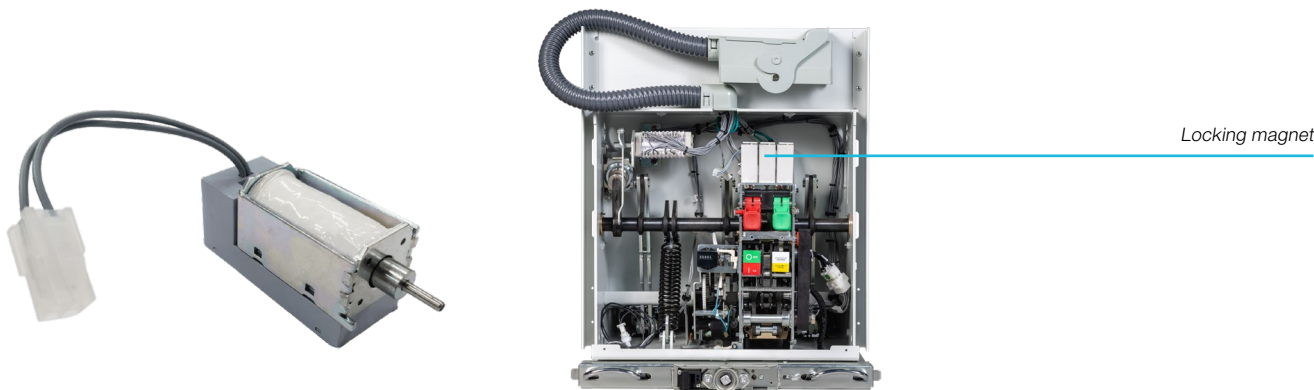

Note: illustrative drawings.

Accessories

Key lock

- It allows locking the VBWB circuit breaker in the OFF position.
- Code for selection: K

Circuit breakers	Reference	Code
VBWB	VBWB-BK1	17175103

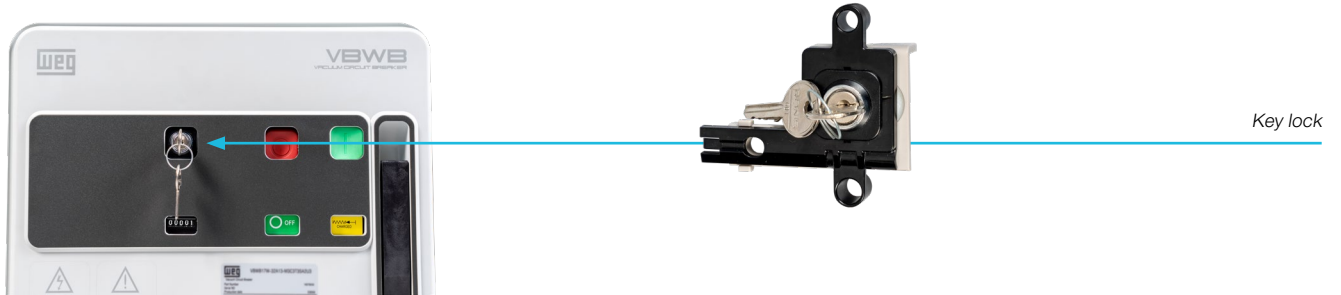

Key lock

Padlocks

- They allow you to simultaneously or individually lock the VBWB operation buttons.
- Code for selection of simultaneous VBWB lock: S
- Code for selection of individual VBWB lock: I
- Code for selection of button protection: P

Circuit breakers	Reference	Code	Action
VBWB	Simultaneous VBWB lock	17175106	Simultaneously locks the opening and closing buttons
VBWB	Individual VBWB lock	17175105	Allows individual lock of the opening or closing pushbuttons
VBWB	VBWB button protection	17175101	Protects the operation buttons and only allows operation with the button key

Simultaneous lock



Individual lock



Individual lock



Accessories

Condenser trip device

This device electrically trips the circuit breaker within a preset time when the control power is OFF. It operates by means of the discharge of a capacitor on the shunt opening release, with that being possible within the period indicated in the table below.

It includes an indication lamp to signal whether the capacitor is charged and a discharge button. Installation on panel door.



Characteristics	Specification	
Reference	VBW-UC D58	VBW-UC D64
Code	12231110	12231111
Power Supply (Vac)	100 - 110	200 - 220
Frequency (Hz)	50/60	50/60
Rated output voltage (V)	140 - 155	280 - 310
Charging time (s)	10	10
Operation time (s)	30	30
Operating voltage range	85 - 110%	85 - 110%
Capacitance (µF)	1,000	560

Terminal arrangement

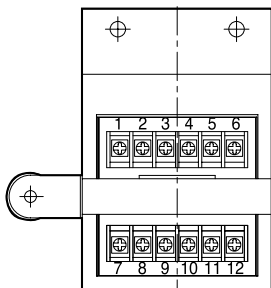

External dimension

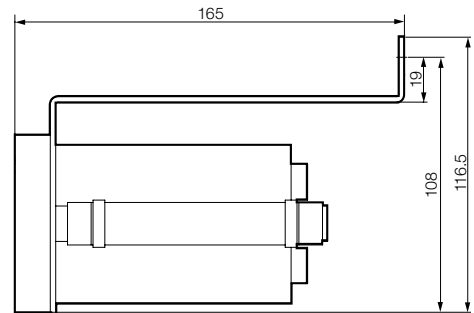
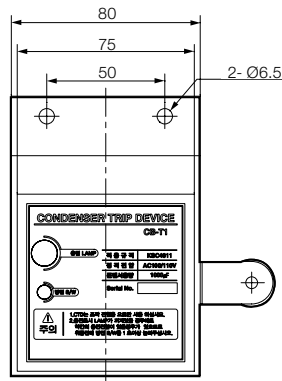

Circuit diagram

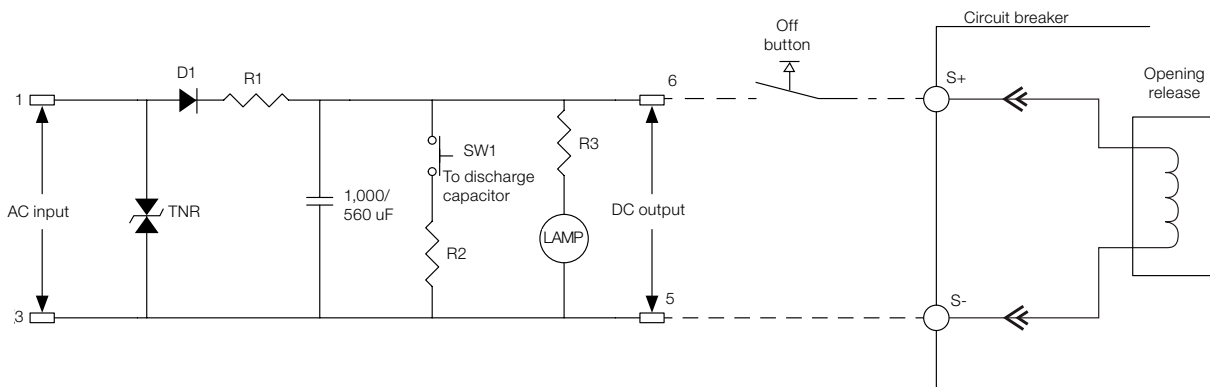









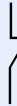

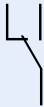

Wiring diagram

The wiring diagrams will be represented with the circuit breaker in the contacts open position, in “Service/Inserted”¹⁾ and spring discharged condition.

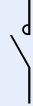
Graphic symbols used in the wiring diagrams, in accordance with IEC 60617, are:

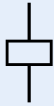
Graphic symbols for wiring diagrams

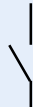
Symbol	Description	Symbol	Description
	Actuator (impulse operated)		Normally closed contact
	Ground (general symbol)		Switch contact
	Structure		Position switch. Normally open.
	Conductor connection point		Position switch. Normally closed.
	Plug and socket (male/female)		Contactor, normally open main contact of contactor
	Diode (general symbol)		Operation device (general symbol)
	Motor (general symbol)		Normally open contact

The designations of the acronyms of the components used in the diagrams, according to the IEC 81346-2 standard, are:

- BER: SOR test device to monitor system continuity of the opening and closing coil winding.
- BGB1: auxiliary contact.
- BGD1: cubicle door position contact.
- BGE3: position switches indicating grounding switch in the open position and not in operation (handle not inserted).
- BGS1: ring charging motor contact.
- MBU: undervoltage release.
- QAB: general circuit breaker accessories.
- RLE1: lock. It mechanically inhibits the closing of the circuit breaker contacts if it is de-energized.
- SFC: button or contact for closing the circuit breaker.
- SFC3: button or contact for electrical operation of circuit breaker insertion.

Note: 1) Situation in which the circuit breaker terminals are in contact with the cubicle terminals.

Wiring diagram

- BGS2: spring charged/discharged indication contact.
- BGT1¹⁾: contacts for indicating circuit breaker in the inserted position.
- BGT2¹⁾: contacts for indicating circuit breaker in the extracted position.
- BGT3¹⁾: circuit breaker position contact; open during insulation displacement.
- MAS: spring charging motor.
- MAT: truck motor.
- MBC: shunt closing release.
- MBO1: shunt opening release.
- MBO2: additional shunt opening release.
- SFC4: button or contact for circuit breaker extraction electrical operation.
- SFO: button or contact for opening the circuit breaker.
- XDB: circuit breaker circuit terminal.
- XDB1: circuit breaker circuit connector
- XDB1, ..., 200: accessory connectors.
- KFA1: auxiliary contactor for circuit breaker electrical insertion operation.
- KFA2: contactor.

WEG circuit breakers have five sets of wiring diagrams. They are composed of the configurations available for sale. They are:

Available configurations to form the circuit breaker wiring diagram

Description of the figures	Figure	Standard circuit breaker	Circuit breaker with additional shunt opening release and motorized truck	Circuit breaker with undervoltage release and non-motorized truck	Circuit breaker with additional shunt opening release and non-motorized truck	Electrical diagram with undervoltage release and motorized truck
Spring charging motor	1	X	X	X	X	X
Shunt closing release	2	X	X	X	X	X
Control locking electromagnet	3		X			X
	4			X	X	
Undervoltage release	5			X		
	6					X
Shunt opening release	7	X	X	X	X	X
Additional shunt opening release	8		X		X	
Spring charged/discharged indication contact	9	X	X	X	X	X
Auxiliary contacts	10		X			X
	11	X		X	X	
Auxiliary contacts of the truck	12		X			X
	13	X		X	X	
Grounding circuit	14	X	X	X	X	X
Insertion/extraction motor circuit	15		X			X

Note: 1) Contacts located inside the truck.

Wiring diagram

Figure 1: Spring charging motor

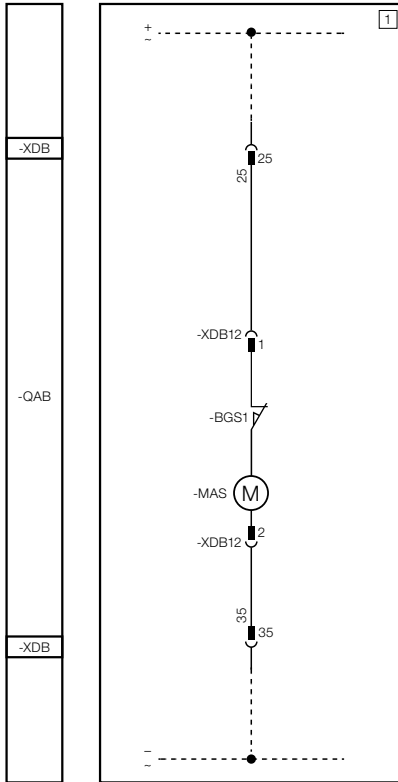

Figure 2: Shut closing release

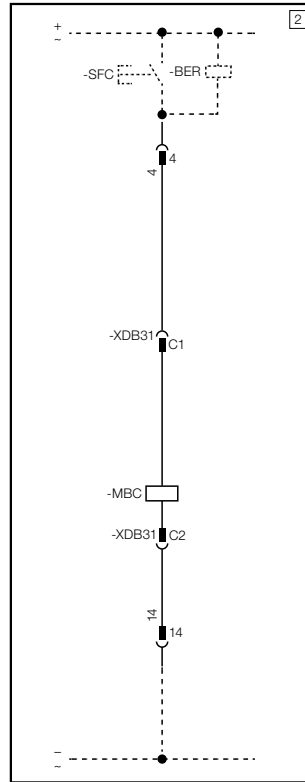

Figure 3: Control locking electromagnet

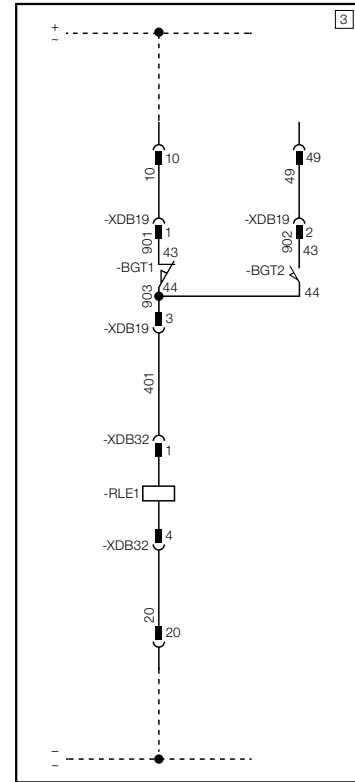

Figure 4: Control locking electromagnet

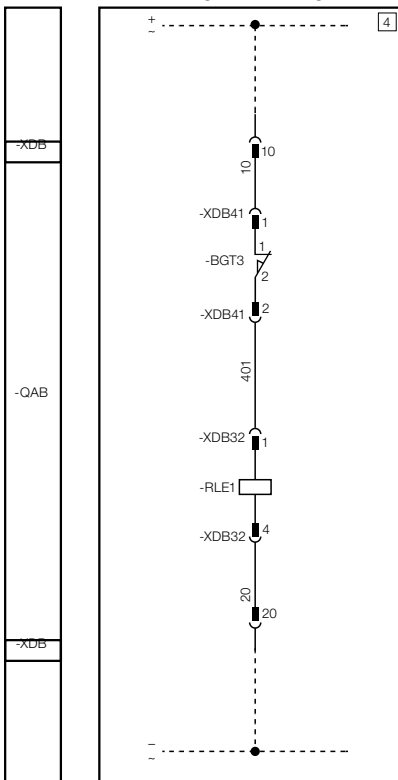

Figure 5: Undervoltage release

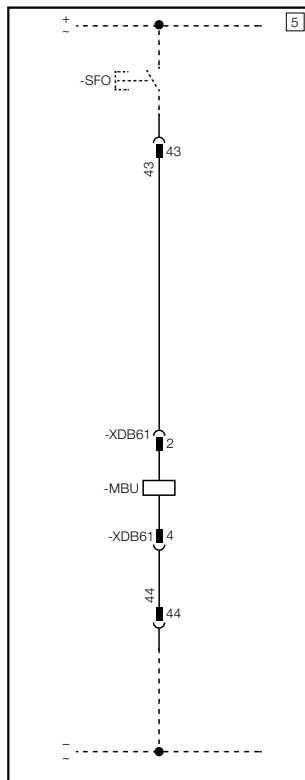
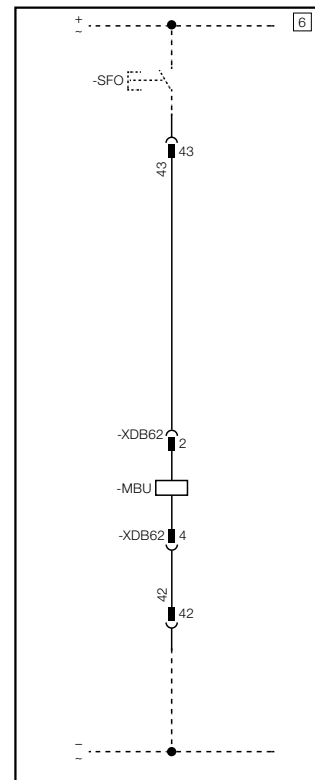

Figure 6: Undervoltage release



Wiring diagram

Figure 7: Shunt opening release

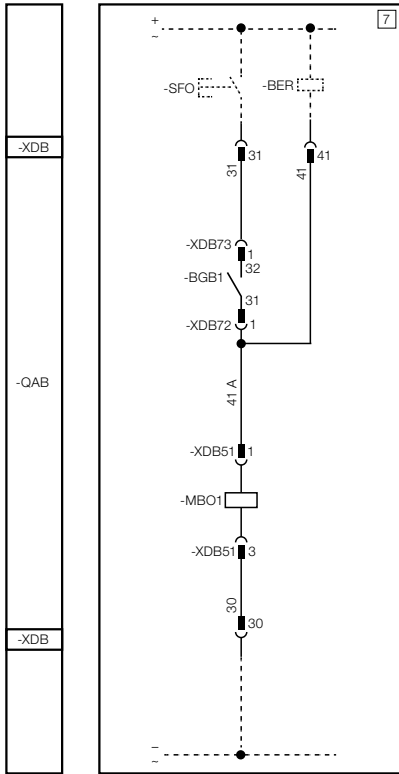

Figure 8: Additional shunt opening release

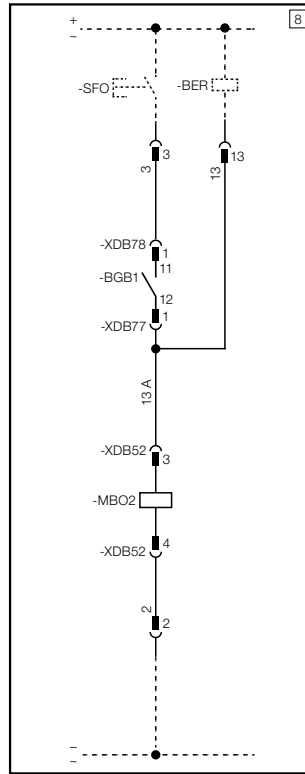

Figure 9: Spring charged/discharged indication contact

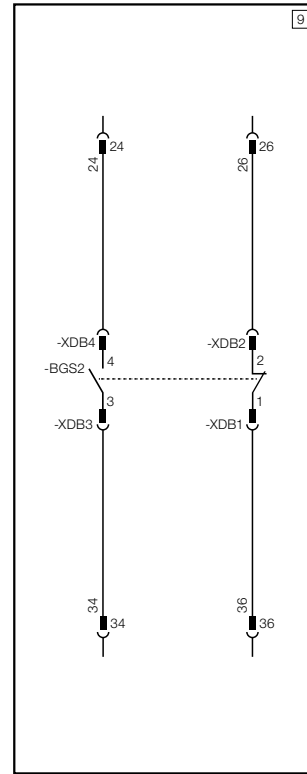
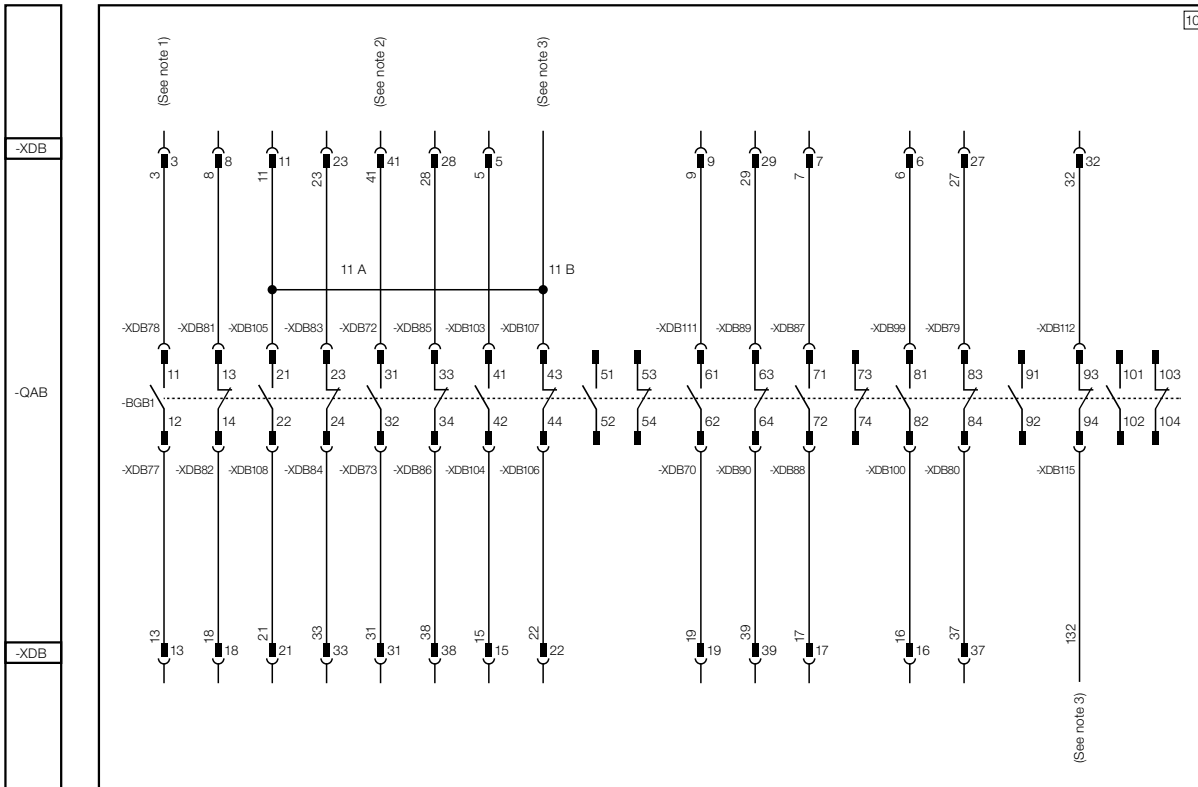

Figure 10: Auxiliary contacts



Notes: 1) When additional shunt opening release is requested, the contact -BGB1 (11-12) is not available.
 2) When shunt opening release is requested, the contact -BGB1 (31-32) is not available.
 3) This circuit continues in figure 15.



Wiring diagram

Figure 11: Auxiliary contacts

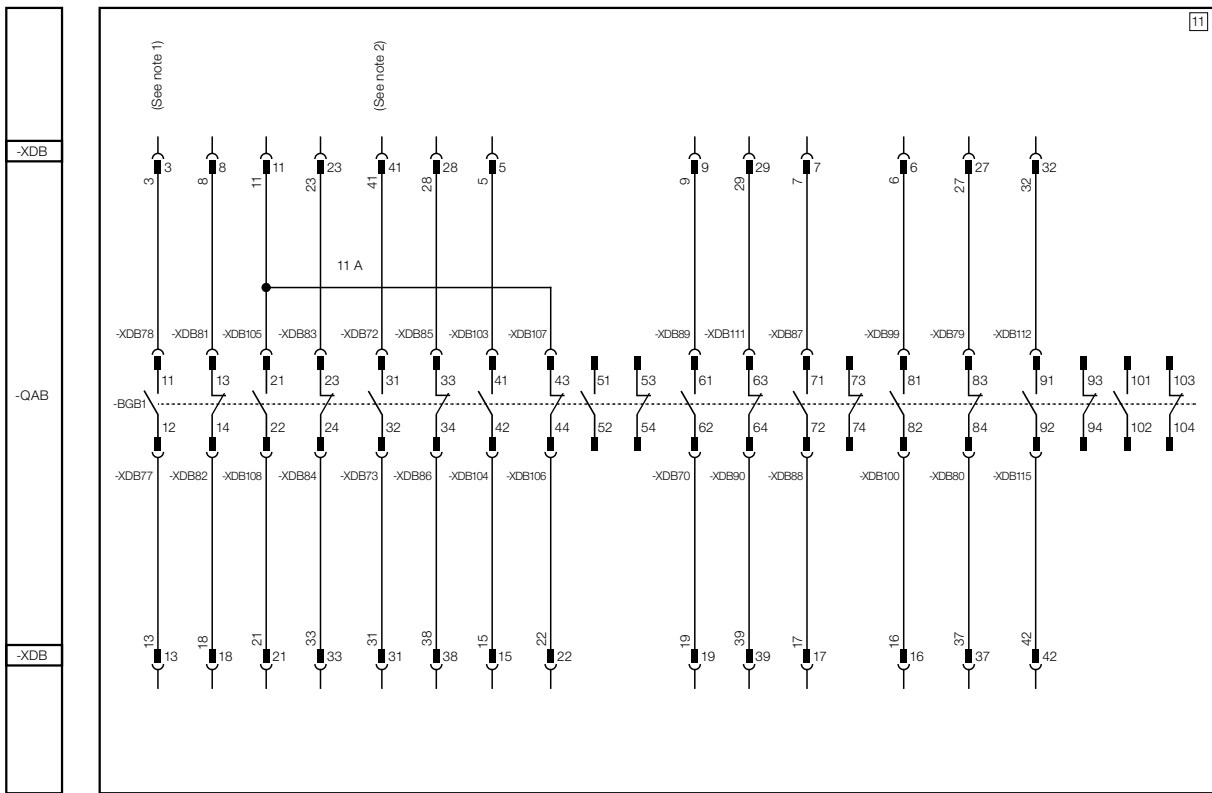

- Notes: 1) When additional shunt opening release is requested, the contact -BGB1 (11-12) is not available.
 2) When shunt opening release is requested, the contact -BGB1 (31-32) is not available.
 3) This circuit continues in figure 15.

Figure 12: Auxiliary contacts of the truck

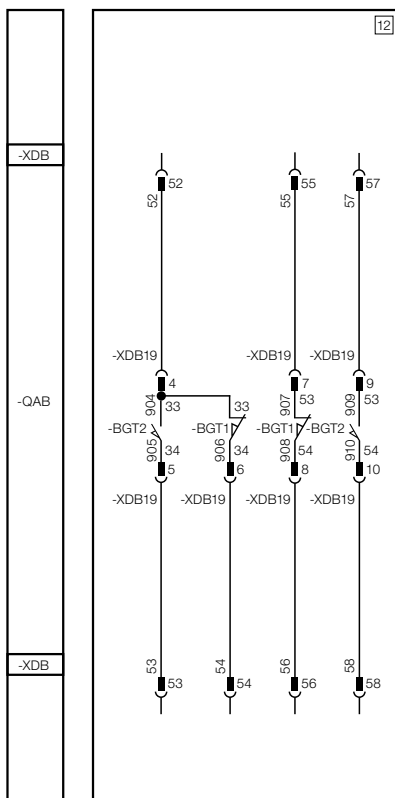

Figure 13: Auxiliary contacts of the truck

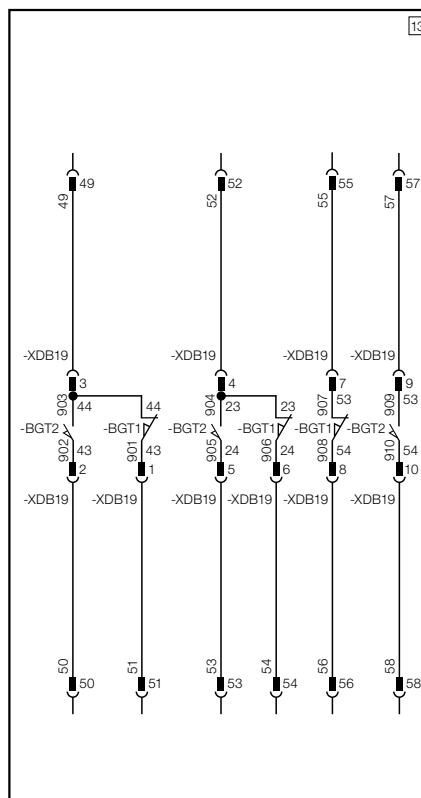
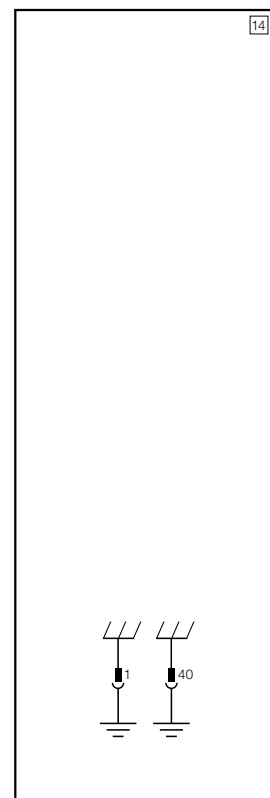
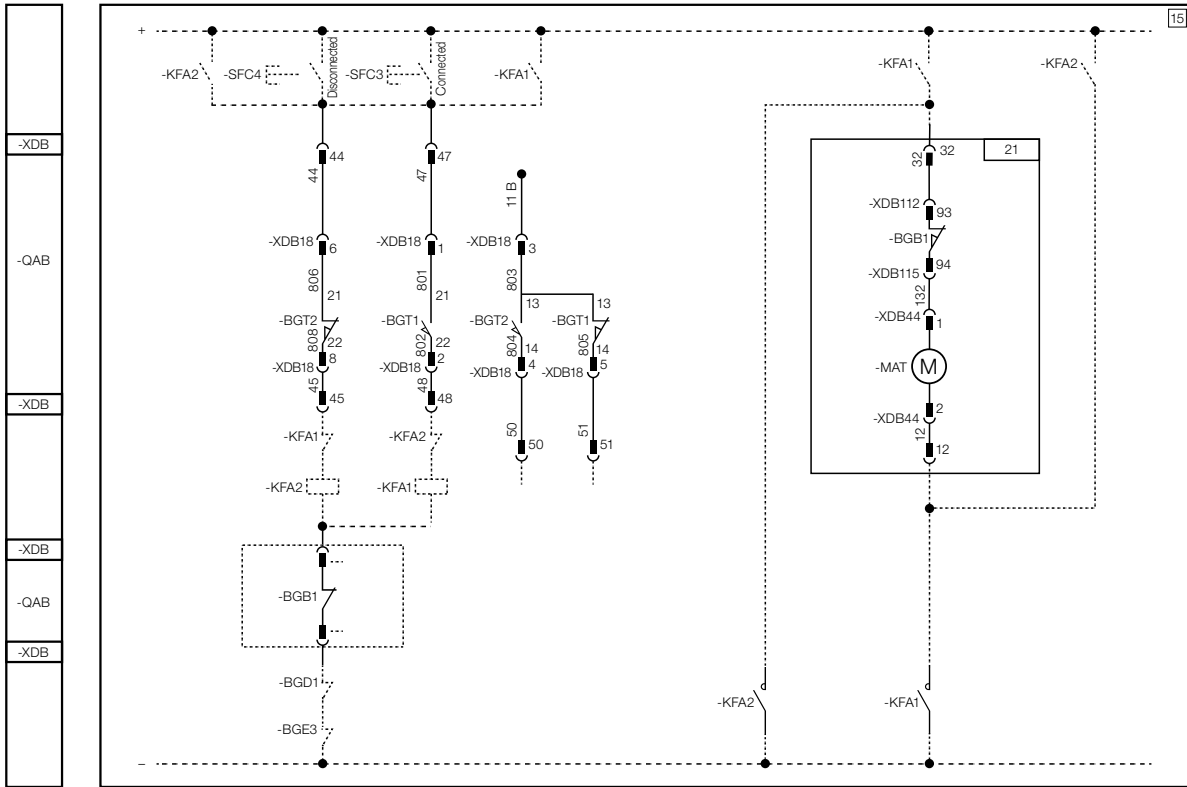

Figure 14: Grounding circuit



Wiring diagram

Figure 15: Insertion/extraction motor circuit



Dimensions

VBWB 17.5 kV, 1,250 A

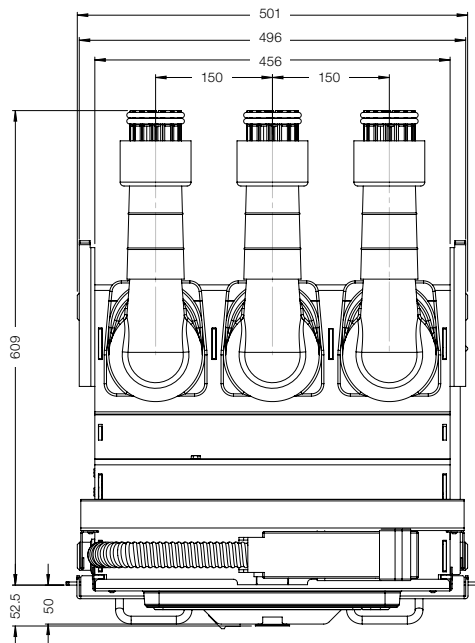
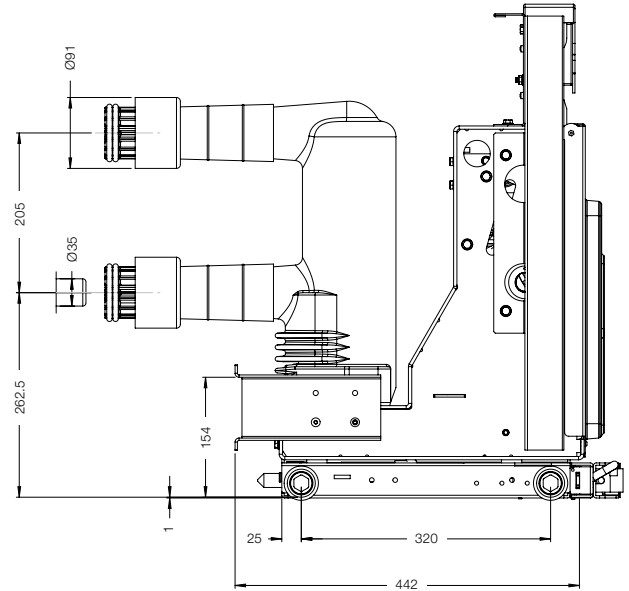
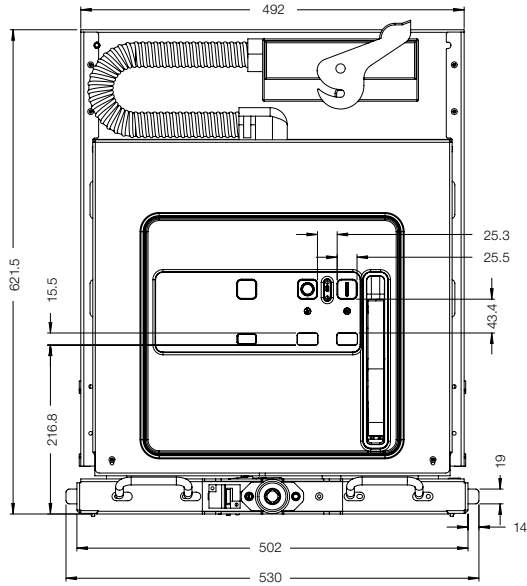

Dimensions

VBWB 17.5 kV, 2,500 A

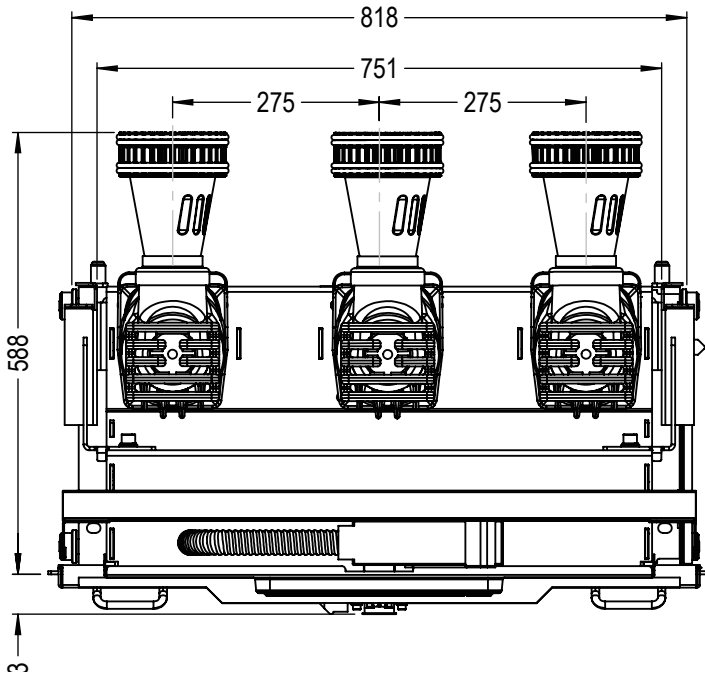
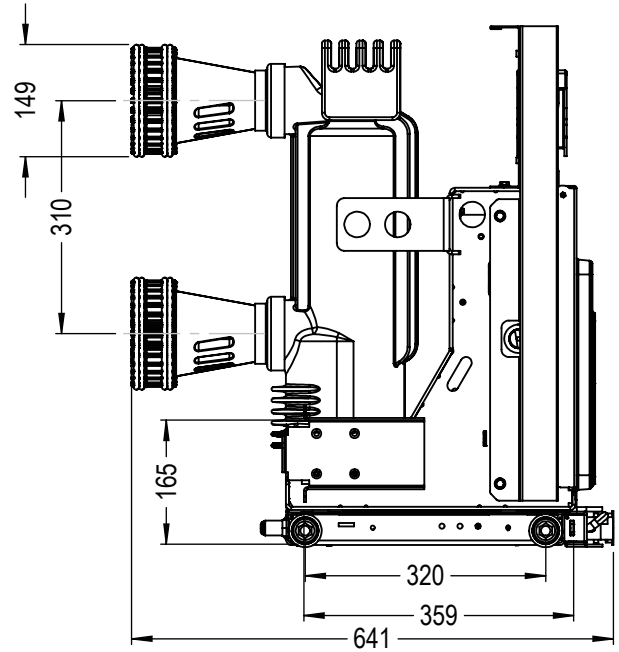
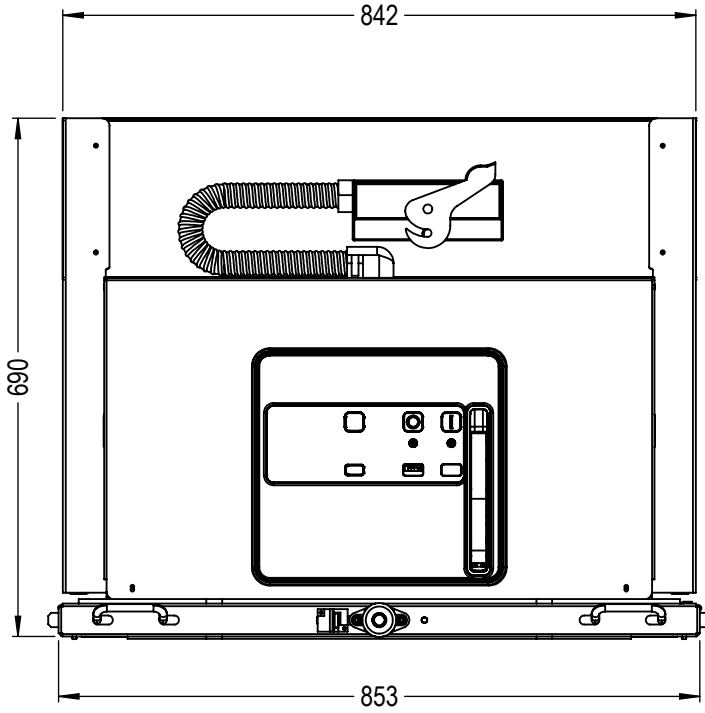

Global presence

is essential, as much
as understanding
your needs.

Global Presence

With more than 45,000 employees worldwide, WEG is one of the largest electric motors, electronic equipments and systems manufacturers. We are constantly expanding our portfolio of products and services with expertise and market knowledge. We create integrated and customized solutions ranging from innovative products to complete after-sales service.

WEG's know-how guarantees our **VBWB - Withdrawable Vacuum Circuit Breaker** is the right choice for your application and business, assuring safety, efficiency and reliability.



Availability is to have a global support network



Partnership is to create solutions that suits your needs



Competitive edge is to unite technology and innovation

Learn More

High performance and reliable products to improve your production process.

Excellence is to provide a whole solution in industrial automation that improves our customers productivity.

Visit:

www.weg.net



youtube.com/wegvideos



The scope of WEG Group solutions is not limited to products and solutions presented in this catalogue.

To see our portfolio, contact us.

For WEG's worldwide operations visit our website



www.weg.net



 +55 47 3276.4000

 automacao@weg.net

 Jaraguá do Sul - SC - Brazil

Cod: 50141352 | Rev: 03 | Date (m/y): 02/2026.

The values shown are subject to change without prior notice.
The information contained is reference values.