

## CFW11

### RHMIF-01

#### Installation Guide Guía de Instalación Guia de Instalação

English/Español/Português



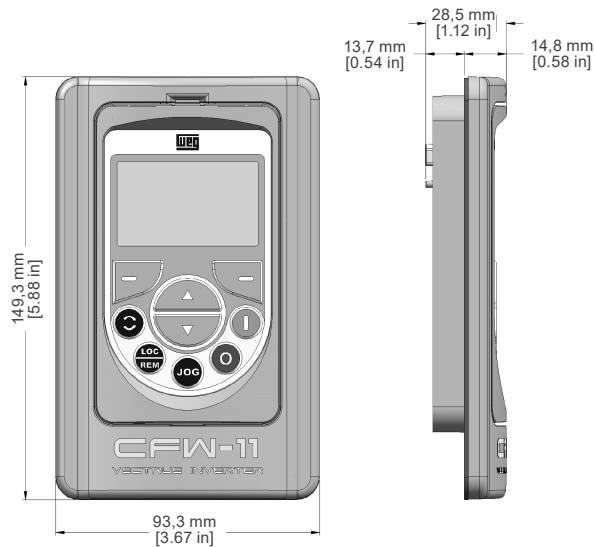

### Details for Mounting Plate Detalles de la Placa de Montaje Detalhes para Chapa de Montagem

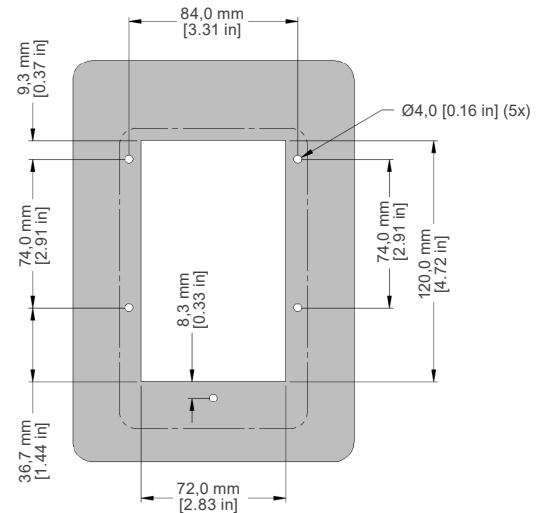

#### NOTE!

- The 2 M3 x 5.8 spacers for securing the cable to the HMI are supplied with the inverter (included in control cable shielding kit).



#### ¡NOTA!

- Los 2 espaciadores M3 x 5.8 para la fijación del cable en la IHM son suministrados con el convertidor de frecuencia (incluido en el kit de puesta a tierra de los cables de control).



#### NOTA!

- Os 2 espaçadores M3 x 5.8 para a fixação do cabo na HMI são fornecidos com o inversor (incluídos no kit de aterramento dos cabos de controle).



#### NOTE!

- The RHMIF kit can be mounted on plates with thickness that vary from 1,5 mm to 3,0 mm (0.06 in to 0.12 in).



#### ¡NOTA!

- El Kit RHMIF puede ser montado en chapas que varían de 1,5 mm a 3,0 mm de espesor.



#### NOTA!

- O Kit RHMIF pode ser montado em chapas que variam de 1,5 mm a 3,0 mm de espessura.