

# SAFETY AND PRECISION IN INSTANT STOPS FOR HAZARDOUS AREAS.

## Industrial Motors

Commercial & Appliance  
Motors

Automation

Digital &  
Systems

Energy

Transmission &  
Distribution

Coatings

## W22Xtb Brake Motor Zone 21/22

The motors are ideal for applications where precise and safe stops, position control and energy savings are essential. By choosing this line, your company will be operating safely and reliably in hazardous areas such as Zone 21 and 22, Groups IIIA, IIIB and IIIC, temperature class T125 °C, thus ensuring the safety in the processing of grain and cereal, textile fiber, powder coatings, polymers, among other applications.

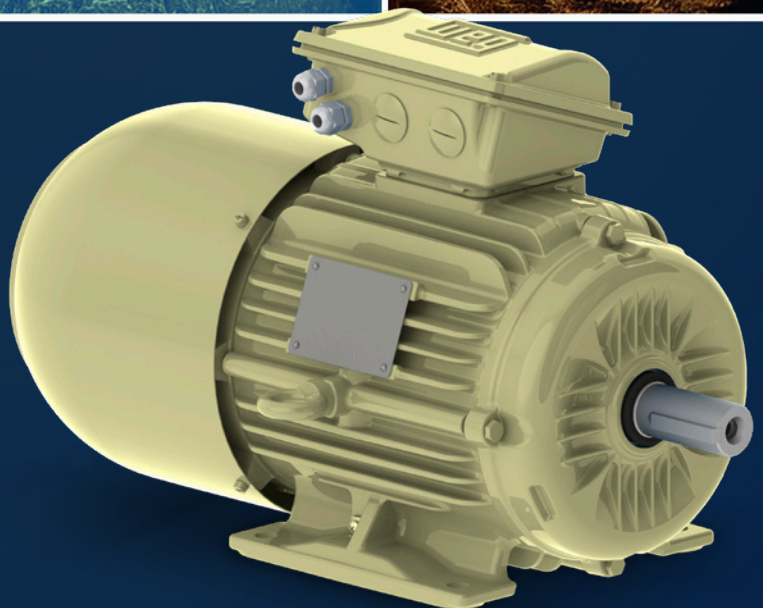

Driving efficiency and sustainability

# W22Xtb Brake Motor

## Zone 21/22

### Standard

- Rated power: 0.16 to 100 cv
- Number of Poles: 2 to 8
- Frames: 63 to 250S/M
- Frequency: 60 Hz
- Efficiency: IR3 Premium
- Voltage:
  - 220/380 V (frames 63 to 132M/L)
  - 220/380/440 V (frames 160M and 250S/M)
- Brake power supply: 220-240 V
- Normally closed brake
- Category: N
- Painting scheme: RAL 1002
- Insulation class: F (DT 80K)
- Mounting B3D
- Frame and terminal box material:
  - Cast iron FC-200
- Fan material:
  - Plastic (frames 63 to 132M/L)
  - Aluminum (frames 160M to 250S/M)
- Shaft material: AISI 1040/45
- Ball bearings
- DE bearing gasket:
  - Oil seal (frames 63 to 80)
  - W3Seal® (frames 90 and 250S/M)
- Thermistor Trip 140 °C

### Optional items

- Vibration level: Level B
- Winding thermal protection: Thermostat, thermistor or Pt100
- Space heater
- Drip cover for vertical mounting
- Tropicalized internal painting
- Stainless steel screws
- Insulation class: "H"
- Able to operate with VSD
- Microswitch to monitor the air gap or brake opening (from frame 100L up)
- Brake power supply:
  - 380-415 V
  - 440-480 V
- Manual Unlocking Lever
- Type-1 Flange for Gearbox

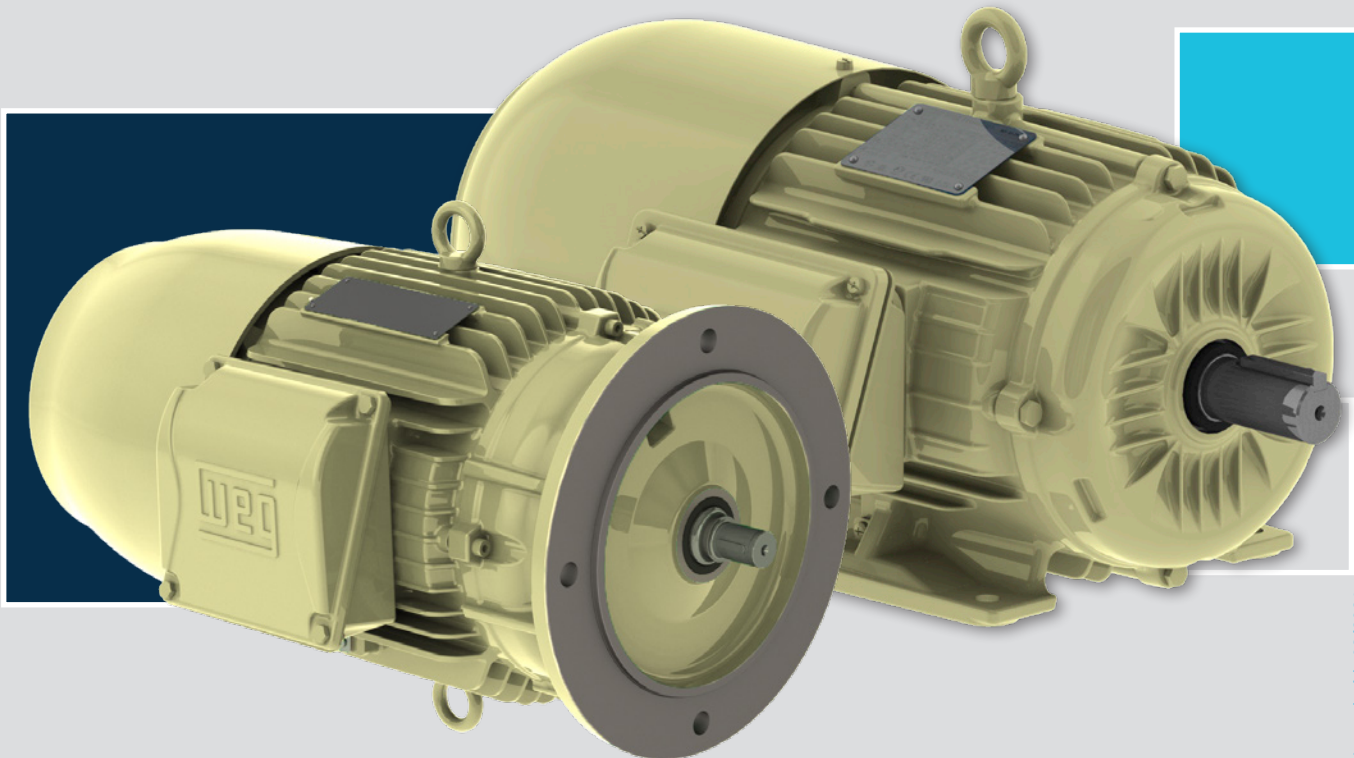

+55 47 3276.4000

motores@weg.net

Jaraguá do Sul - SC - Brazil