

DeviceNet

CFW900-CCAN-W

User's Guide

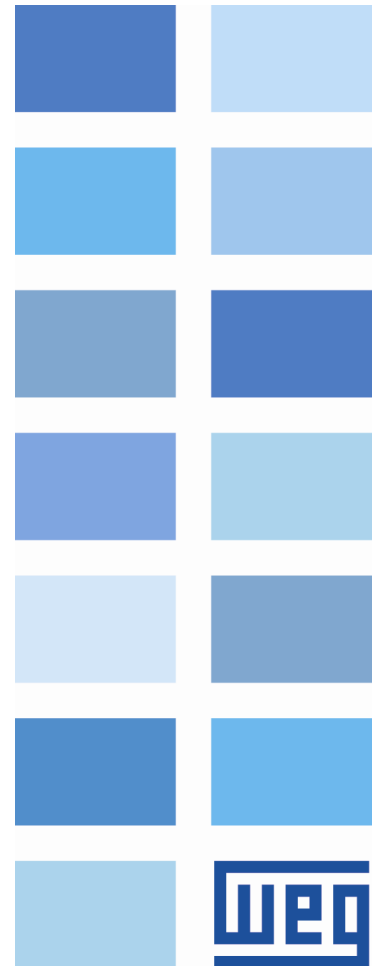



DeviceNet User's Guide

Series: CFW900

Software version: 1.07.XX

Language: English

Document: 10009145116 / 03

Publication Date: 04/2023

The information below describes the reviews made in this manual.

Version	Revision	Description
V1.02.XX	R00	First edition.
V1.04.XX	R01	General review and parameter list update.
V1.06.XX	R02	General review and parameter list update.
V1.07.XX	R03	General review and parameter list update.

CONTENTS

ABOUT THE MANUAL	6
ABBREVIATIONS AND DEFINITIONS	6
NUMERICAL REPRESENTATION	6
DOCUMENTS	6
1 MAIN CHARACTERISTICS	7
2 INTERFACE DESCRIPTION	8
2.1 DEVICENET ACCESSORY	8
2.2 CONNECTOR	8
2.3 POWER SUPPLY	8
3 DEVICENET NETWORK INSTALLATION	9
3.1 BAUD RATE	9
3.2 ADDRESS IN THE DEVICENET NETWORK	9
3.3 TERMINATION RESISTOR	9
3.4 CABLE	9
3.5 CONNECTION IN THE NETWORK	10
4 S STATUS	11
S5 Communications	11
S5.1 Status and Commands	11
S5.7 CAN/CANopen/DNet	13
5 C CONFIGURATION	16
C9 COMMUNICATIONS	16
C9.2 I/O Data	16
C9.8 CAN/CANopen/DNet	17
6 OPERATION IN THE DEVICENET NETWORK	25
6.1 CYCLIC DATA	25
6.1.1 Input words	25
6.1.2 Output Words	26
6.2 ACYCLIC DATA	27
6.3 EDS FILE	27
6.4 SUPPORTED OBJECT CLASSES	27
6.4.1 Identity Class (01h)	28
6.4.2 Message Router Class (02h)	28
6.4.3 DeviceNet Class (03h)	28
6.4.4 Assembly Class (04h)	28
6.4.5 Connection Class (05h)	29
6.4.5.1 Instance 1: Explicit Message	29
6.4.5.2 Instance 2: Polled	30
6.4.5.3 Instance 4: Change of State/Cyclic	30
6.4.6 Motor Data Class (28h)	30
6.4.7 Control Supervisor Class (29h)	31
6.4.8 AC/DC Drive Class (2Ah)	31
6.4.9 Acknowledge Handler Class (2Bh)	32
6.4.10 Manufacturer Specific Classes (64h, 65h and 66h)	32

7 STARTUP GUIDE	33
7.1 INSTALLING THE ACCESSORY	33
7.2 CONFIGURING THE EQUIPMENT	33
7.3 CONFIGURING THE MASTER	33
7.4 COMMUNICATION STATUS	34
7.5 OPERATION USING PROCESS DATA	34
7.6 ACCESS TO PARAMETERS – ACYCLIC MESSAGES	34
8 FAULTS AND ALARMS	35
9 PARAMETER STRUCTURE	36
10 QUICK REFERENCES	38

ABOUT THE MANUAL

This manual supplies the necessary information for the operation of the CFW900 frequency inverter using the DeviceNet protocol. This manual must be used together with the CFW900 user's manual and programming manual.

ABBREVIATIONS AND DEFINITIONS

ASCII	American Standard Code for Information Interchange
CAN	Controller Area Network
CiA	CAN in Automation
CIP	Common Industrial Protocol
CRC	Cyclic Redundancy Check
HMI	Human-Machine Interface
ISO	International Organization for Standardization
ODVA	Open DeviceNet Vendor Association
OSI	Open Systems Interconnection
PLC	Programmable Logic Controller
ro	read only
rw	read/write
RTR	Remote Transmission Request

NUMERICAL REPRESENTATION

Decimal numbers are represented by means of digits without suffix. Hexadecimal numbers are represented with the letter 'h' after the number. Binary numbers are represented with the letter 'b' after the number.

DOCUMENTS

The DeviceNet protocol was developed based on the following specifications and documents:

Document	Version	Source
CAN Specification	2.0	CiA
Volume One - Common Industrial Protocol (CIP) Specification	3.2	ODVA
Volume Three - DeviceNet Adaptation of CIP	1.4	ODVA
Planning and Installation Manual - DeviceNet Cable System	PUB00027R1	ODVA

In order to obtain this documentation, consult ODVA, which is nowadays the organization that keeps, publishes and updates the information related to the DeviceNet network.

1 MAIN CHARACTERISTICS

Below are the main characteristics for communication of the frequency inverter CFW900 with DeviceNet accessory.

- Uses the Set of Predefined Master/Slave Connections (Group 2 Only Server).
- It is supplied with an EDS file for the network master configuration.
- Allows up to 50 input words and 50 output words for cyclic data communication.
- Acyclic data available for parameterization (Explicit Messages).

2 INTERFACE DESCRIPTION

2.1 DEVICENET ACCESSORY

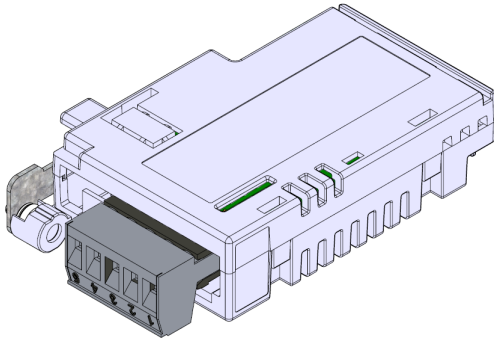

CFW900-CCAN-W:

- Supplied items:
 - Installation guide.
 - CANopen/DeviceNet communication module.

2.2 CONNECTOR

The DeviceNet communication module has a 5-wire plug-in connector with the following pin assignment:

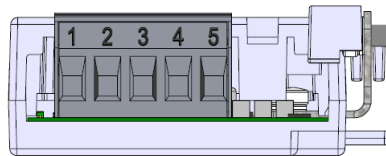

Table 2.1: Pin assignment of connector for DeviceNet interface

Pin	Name	Function
1	V-	Negative pole of the power supply
2	CAN_L	Communication signal CAN_L
3	Shield	Cable shield
4	CAN_H	Communication signal CAN_H
5	V+	Positive pole of the power supply

2.3 POWER SUPPLY

The power supply of the network must be able to supply enough current to power up the equipments and interfaces connected to the network. The data for individual consumption and input voltage are presented in tables 2.2 and 2.3.

Table 2.2: Power Supply (Vdc)

Minimum	Maximum	Recommended
11 V	30 V	24 V

Table 2.3: Current

Typical	Maximum
30 mA	50 mA

3 DEVICENET NETWORK INSTALLATION

The DeviceNet network, such as several industrial communication networks, for being many times applied in aggressive environments with high exposure to electromagnetic interference, requires that certain precautions be taken in order to guarantee a low communication error rate during its operation. Recommendations to perform the connection of the product in this network are presented next.



NOTE!

Detailed recommendations on how to perform the installation are available at document "Planning and Installation Manual" (item **DOCUMENTS**).

3.1 BAUD RATE

Equipments with DeviceNet interface generally allow the configuration of the desired baud rate, ranging from 125 Kbit/s até 500 Kbit/s. The baud rate that can be used by the equipment depends on the length of the cable used in the installation. The table 3.1 shows the baud rates and the maximum cable length that can be used in the installation, according to the protocol recommendation.

Table 3.1: Supported baud rates and cable length

Baud Rate	Cable length
125 Kbit/s	500 m
250 Kbit/s	250 m
500 Kbit/s	100 m

All network equipment must be programmed to use the same communication baud rate.

3.2 ADDRESS IN THE DEVICENET NETWORK

Each DeviceNet network device must have an address or MAC ID, and may range from 0 to 63. This address must be unique for each equipment.

3.3 TERMINATION RESISTOR

The use of termination resistors at the ends of the bus is essential to avoid line reflection, which can impair the signal and cause communication errors. Termination resistors of 121Ω | 0.25 W must be connected between the signals CAN_H and CAN_L at the ends of the main bus.

3.4 CABLE

The connection of CAN_L and CAN_H signals must be done with shielded twisted pair cable. The following table shows the recommended characteristics for the cable.

Table 3.2: DeviceNet cable characteristics

Cable Length (m)	Resistance per Meter (m Ω /m)	Conductor Cross Section (mm ²)
0 ... 40	70	0.25 ... 0.34
40 ... 300	<60	0.34 ... 0.60
300 ... 600	<40	0.50 ... 0.60
600 ... 1000	<26	0.75 ... 0.80

It is necessary to use a twisted pair cable to provide additional 24Vdc power supply to equipments that need this signal. It is recommended to use a certified DeviceNet cable.

3.5 CONNECTION IN THE NETWORK

In order to interconnect the several network nodes, it is recommended to connect the equipment directly to the main line without using derivations. If you use derivations, the limits of length for derivation defined by the DeviceNet specification must be observed. During the cable installation the passage near to power cables must be avoided, because, due to electromagnetic interference, this makes the occurrence of transmission errors possible.

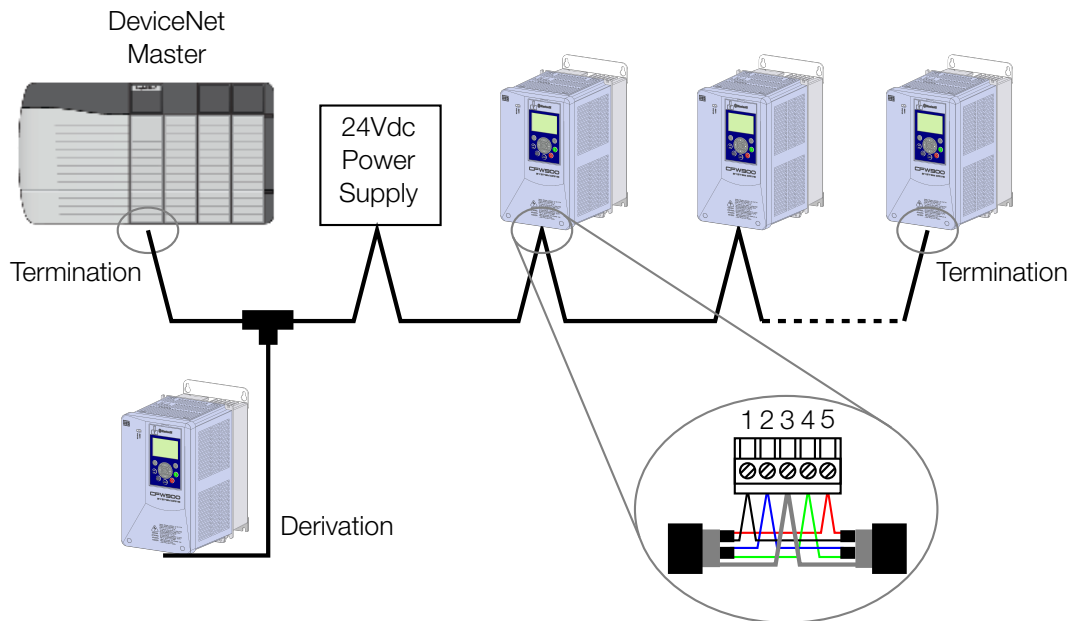

Figure 3.1: DeviceNet network installation example

In order to avoid problems with current circulation caused by difference of potential among ground connections, it is necessary that all the devices be connected to the same ground point.

To avoid voltage difference problems between the power supplies of the network devices, it is recommended that the network is fed by only one power supply and the signal is provided to all devices through the cable. If it is required more than one power supply, these should be referenced to the same point. Use the power supply to power the bus cable system only.

The maximum number of devices connected to a single segment of the network is limited to 64. Repeaters can be used for connecting a bigger number of devices.

4 S STATUS

This menu contains the status information of the inverter, motor, control accessories and networks. It is also possible to access information related to the functional safety of the inverter. It allows viewing the reading variables of the CFW900.

NOTE!

All parameters in this menu can only be viewed on the HMI display, and cannot be changed by the user, unless they are linked to the parameters in the **Configuration** menu.

S5 COMMUNICATIONS

It allows viewing the parameters used for monitoring and controlling the CFW900 inverter using communication interfaces.

S5.1 Status and Commands

It allows viewing the CFW900 logical status and commands.

S5.1 Status and Commands

.1 Status Word 1	0 ... 15 Bit
.2 Speed	-200.00 ... 200.00 %
.3 Status Word 2	0 ... 15 Bit
.4 Status Word 3	0 ... 1 Bit

.1 Status Word 1 It indicates the operating status of the inverter. Each bit represents a status.

Bit	Value/Description
Bit 0 STO	0 = No: STO function is inactive (inverter operational) 1 = Yes: STO function is active (inverter locked)
Bit 1 Run Command	0 = No: no run command active 1 = Yes: run command active
Bit 2 Local	0 = No: inverter in Remote command mode 1 = Yes: inverter in Local command mode (via HMI)
Bit 3 Not used	Not used.
Bit 4 No Quick Stop	0 = No: quick stop command active 1 = Yes: no quick stop command active
Bit 5 2nd Ramp	0 = No: 1st Ramp acceleration and deceleration by C6.1.1 and C6.1.2 1 = Yes: 2nd Ramp acceleration and deceleration by C6.1.4 and C6.1.5
Bit 6 Config. Mode	0 = No: inverter in normal operation 1 = Yes: inverter in configuration status. It indicates a special condition in which the inverter cannot be enabled
Bit 7 Alarm	0 = No: without alarm 1 = Yes: with alarm active
Bit 8 Running	0 = No: motor is stopped 1 = Yes: motor is running according to reference and command
Bit 9 Enabled	0 = No: inverter is general disabled 1 = Yes: inverter is general enabled
Bit 10 Reverse	0 = No: motor running in the forward direction 1 = Yes: motor running in the reverse direction
Bit 11 JOG	0 = No: no JOG command active 1 = Yes: JOG command is active
Bit 12 Remote 2	0 = No: inverter in Remote 1 command mode 1 = Yes: inverter in Remote 2 command mode
Bit 13 Undervoltage	0 = No: without undervoltage 1 = Yes: with undervoltage
Bit 14 Not used	Not used.
Bit 15 Fault	0 = No: normal operation 1 = Yes: fault acting

.2 Speed It indicates the actual speed of the motor driven by the inverter in percentage of the maximum speed.

- S5.1.2 = 0.00 % ⇒ motor speed = 0 rpm
- S5.1.2 = 100.00 % ⇒ motor speed = C4.3.1.1.2

Intermediate or higher speed values can be obtained by using this scale. For example, if the value read is 25.0 %, considering C4.3.1.1.2 = 1800 rpm, to obtain the value in rpm you must calculate:

100.00 % : 1800 rpm
 25.00 % : Speed

$$\text{Speed} = \frac{25.00 \times 1800}{100.00}$$

Speed = 450 rpm

Negative values indicate motor rotating in the reverse direction of rotation.

.3 Status Word 2 It indicates other status of the inverter functions. Each bit represents a status.

Bit	Value/Description
Bit 0 Self-tuning	0 = No: inverter is not running the Self-tuning routine. 1 = Yes: inverter is running the Self-tuning routine for estimating motor parameters
Bit 1 Not used	Not used.
Bit 2 Pre-Charge OK	0 = No: pre-charge of the DC link capacitors not completed 1 = Yes: pre-charge of the DC link capacitors completed
Bit 3 SF Reduction	0 = No: output frequency reduction inactive 1 = Yes: output frequency reduction active
Bit 4 Not used	Not used.
Bit 5 Decel. Ramp	0 = No: no deceleration 1 = Yes: inverter decelerating
Bit 6 Accel. Ramp	0 = No: no acceleration 1 = Yes: inverter accelerating
Bit 7 Freeze Ramp	0 = No: ramp in normal operation 1 = Yes: the path of the ramp is frozen by some command source or internal function
Bit 8 Setpoint OK	0 = No: motor speed has not reached the reference yet 1 = Yes: motor speed has reached the reference
Bit 9 DC Voltage Limitation	0 = No: DC link limitation or current limitation inactive 1 = Yes: DC link limitation or current limitation active
Bit 10 Current Limitation	0 = No: current limitation inactive 1 = Yes: current limitation active
Bit 11 Torque Limitation	0 = No: torque limitation inactive 1 = Yes: torque limitation active
Bit 12 Ride-Through	0 = No: Ride-through not running 1 = Yes: running Ride-through
Bit 13 Flying Start	0 = No: Flying start not running 1 = Yes: running Flying start
Bit 14 DC Braking	0 = No: DC braking inactive 1 = Yes: DC braking active
Bit 15 PWM pulses	0 = No: PWM voltage pulses at the output disabled 1 = Yes: PWM voltage pulses at the output enabled

.4 Status Word 3 Indicates other states of the inverter functions. Each bit represents a state.

Bit	Value/Description
Bit 0 SD Card	SD card detection is performed only during the inverter initialization, so the inverter does not detect SD card disconnection during operation. 0 = No: SD card not connected 1 = Yes: SD card connected
Bit 1 Not used	Not used.

S5.7 CAN/CANopen/DNet

Status of the CAN communication accessory and the protocols that use this interface.

S5.7 CAN/CANopen/DNet

.1 CAN Controller Status	0 ... 6
.2 Control Word	0 ... 7 Bit
.3 Speed Reference	-200.00 ... 200.00 %
.5 Received Telegrams	0 ... 65535
.6 Transmitted Telegrams	0 ... 65535
.7 Bus Off Counter	0 ... 65535
.8 Lost Messages	0 ... 65535
.11 DNet Network Status	0 ... 5
.12 DNet Master Status	0 ... 1

.1 CAN Controller Status It allows identifying whether the CAN interface is properly installed, and whether the communication presents errors.

Indication	Description
0 = Disabled	CAN interface inactive. It occurs when the equipment does not have a CAN protocol programmed in C9.8.1.
1 = Auto-Baud	Running function for automatic baud rate detection (only for DeviceNet protocol).
2 = CAN Active	CAN interface active and without error.
3 = Warning	CAN controller has reached the warning status.
4 = Error Passive	CAN controller has reached error passive status.
5 = Bus Off	CAN controller has reached bus off status.
6 = No Bus Power	The CAN interface has no power supply between pins 1 and 5 of the connector.

.2 Control Word It indicates the status of the control word via CAN interface. This parameter can only be changed via CAN interface. For other sources, only read access is allowed.

For the commands written in this parameter to be executed, the inverter must be programmed to be commanded via CAN/CO/DN. This programming is done through menu C4.

Each bit of this word represents a command that can be executed on the inverter.

Bit	Value/Description
Bit 0 Enable Ramp	0 = No: it stops the motor by deceleration ramp 1 = Yes: the motor turns according to the acceleration ramp until reaching the speed reference value
Bit 1 General Enable	0 = No: it disables the inverter completely, interrupting the motor power supply 1 = Yes: it enables the inverter completely, allowing the operation of the motor
Bit 2 Run Reverse	0 = No: turn the motor in the direction of the reference signal (forward direction) 1 = Yes: run the motor in the opposite direction of the reference signal (reverse direction)
Bit 3 Enable JOG	0 = No: it disables the JOG function 1 = Yes: it enables the JOG function
Bit 4 R1/R2 Mode	0 = R1: it selects the Remote 1 command mode 1 = R2: it selects the Remote 2 command mode
Bit 5 2nd Ramp	0 = No: 1st Ramp acceleration and deceleration according to parameters C6.1.1 and C6.1.2 1 = Yes: 2nd Ramp acceleration and deceleration according to parameters C6.1.4 and C6.1.5
Bit 6 No Quick Stop	0 = No: it enables quick stop 1 = Yes: it disables quick stop
Bit 7 Fault Reset	0 = No: not used 1 = Yes: in the transition, if a fault is active, it resets the fault

.3 Speed Reference It indicates the speed reference sent via CAN interface to the motor driven by the inverter in percentage of the maximum speed. This parameter can only be changed via CAN interface. For other sources, only read access is allowed.

For the reference written in this parameter to be used, the inverter must be programmed to use the speed reference

via CAN/CO/DNET. This programming is done through menu C4.

- S5.7.3 = 0.00 % ⇒ speed reference = 0 rpm
- S5.7.3 = 100.00 % ⇒ speed reference = C4.3.1.1.2

Intermediate or higher speed values can be obtained by using this scale. For example, if the desired value for the reference is 900 rpm, considering C4.3.1.1.2 = 1800 rpm, it should be calculated:

100.00 % : 1800 rpm
 Reference % : 900 rpm

$$\text{Reference \%} = \frac{900 \times 100.00}{1800}$$

Reference % = 50 %

Negative values can be used to reverse the direction of rotation of the motor. The direction of rotation of the motor, however, also depends on the value of the rotation direction command bit in S1.6.1:

- Bit Rotation Direction = 1 and S5.7.3 > 0: reference for the forward direction
- Bit Rotation Direction = 1 and S5.7.3 < 0: reference for the reverse direction
- Bit Rotation Direction = 0 and S5.7.3 > 0: reference for the reverse direction
- Bit Rotation Direction = 0 and S5.7.3 < 0: reference for the forward direction

.5 Received Telegrams This parameter works as a cyclic counter that is incremented every time a CAN telegram is received. It provides feedback to the operator if the device is able to communicate with the network.

.6 Transmitted Telegrams This parameter works as a cyclic counter that is incremented every time a CAN telegram is transmitted. It provides feedback to the operator if the device is able to communicate with the network.

.7 Bus Off Counter Cyclic counter that indicates the number of times the equipment went into the bus off state on the CAN network.

.8 Lost Messages It is a cyclic counter that indicates the number of messages the CAN interface received but could not be processed. In case the number of lost messages frequently increases, it is recommended to reduce the baud rate used in the CAN network.



NOTE!

These counters are reset to zero whenever the equipment is turned off, reset or reach the maximum limit set in the parameter.

.11 DNet Network Status It indicates the DeviceNet network status.

Indication	Description
0 = Offline	No power supply or not online. Communication cannot be established.
1 = Online Not Conn.	Device online but not connected. Slave has successfully completed the MacID verification procedure. This means that the baud rate setting is correct (or correctly detected in case of using autobaud) and that there are no other nodes in the network with the same address. However, at this stage, there is still no communication with the master.
2 = Online Connected	Device operational and under normal conditions. Master allocated a set of I/O type connections with the slave. In this step, the data exchange takes place through I/O type connections.
3 = Conn. Timed Out	One or more I/O type connections timed out.
4 = Link Failure	It indicates that the slave cannot enter the network due to address problems or due to bus off. Check if the address is not already being used by another device, if the baud rate selected is correct or if there are problems in the installation.
5 = Auto-Baud	Equipment running routine of the autobaud mechanism.

.12 DNet Master Status It indicates the status of the DeviceNet network master. It may be in “operation mode” (Run) or in “configuration mode” (Idle).

Indication	Description
0 = Run	Reading and writing telegrams are processed and updated normally by the master
1 = Idle	Only reading telegrams from the slaves are updated by the master. Writing, in this case, is disabled

NOTE!

When communication is disabled, this parameter does not represent the actual status of the master.

5 C CONFIGURATION

It allows changing the setting parameters of CFW900. Depending on the property of the parameter, it is possible to adjust its value according to the table below.

Property	Description
Stopped	Parameter can only be changed when the motor is stopped.
Model	Default value may change depending on the inverter model.

NOTE!

Parameter options with the description "Reserved" are for WEG's exclusive use.

C9 COMMUNICATIONS

It sets the CFW900 to exchange information via communication network.

C9.2 I/O Data

It sets the cyclic data exchange area of the communication networks.

C9.2.1 Reading Data

It configures a set of 16-bit parameters to be read via communication network.

C9.2.1 Reading Data
C9.2.1.1 Word #1

C9.2.1.1 to C9.2.1.100

C9.2.1 Reading Data
C9.2.1.100 Word #100

Range: 0 ... 9999

Default: 0

Properties: Stopped

Description:

It selects the address (Net Id) of the parameter whose content should be provided in the reading area for the fieldbus interfaces (input: sent to the network master).

The size of the referenced parameter must be taken into account. If the data size is greater than 16 bits, the configuration parameter of the next programmable word must be set to the same address.

C9.2.2 Writing Data

It configures a set of 16-bit parameters to be written via communication network.

C9.2.2 Writing Data
C9.2.2.2 Word #1

C9.2.2.2 to C9.2.2.101

C9.2.2 Writing Data
C9.2.2.101 Word #100

Range:	0 ... 9999	Default: 0
Properties:	Stopped	

Description:

It selects the address (Net Id) of the parameter whose content should be provided in the writing area for the fieldbus interfaces (output: received from the network master).

The size of the referenced parameter must be taken into account. If the data size is greater than 16 bits, the configuration parameter of the next programmable word must be set to the same address.

C9.8 CAN/CANopen/DNet

It sets CAN communication accessory and protocols that use this interface.

C9.8 CAN/CANopen/DNet
C9.8.1 Protocol

Range:	0 ... 2	Default: 2
Properties:	Stopped	

Description:

It allows selecting the desired protocol for the CAN interface.

Indication	Description
0 = Disabled	It disables the CAN interface.
1 = CANopen	It enables the CAN interface with CANopen protocol.
2 = DeviceNet	It enables the CAN interface with DeviceNet protocol.

C9.8 CAN/CANopen/DNet
C9.8.2 Address

Range:	0 ... 127	Default: 63
Properties:	Stopped	

Description:

It allows programming the address used for CAN communication of the device. It is necessary that each device on the network has a different address from the others. Valid addresses for this parameter depend on the protocol selected in C9.8.1:

- C9.8.1 = 1 (CANopen): valid addresses: 1 to 127.
- C9.8.1 = 2 (DeviceNet): valid addresses: 0 to 63.

NOTE!

After changing this configuration, the modification will only take effect if the CAN interface is not exchanging cyclical data with the network.

C9.8 CAN/CANopen/DNet
C9.8.3 Baud Rate

Range:	0 ... 5	Default: 0
Properties:	Stopped	

Description:

It allows programming the desired value for the baud rate of the CAN interface in bit per second. This rate must be the same for all devices connected to the network. The supported baud rates for the device depend on the protocol set in C9.8.1:

- C9.8.1 = 1 (CANopen): any rate indicated in this parameter can be used, but it does not have the automatic rate detection function (autobaud).
- C9.8.1 = 2 (DeviceNet): Only rates of 500, 250 and 125 Kbit/s are supported. Other options enable the automatic rate detection function (autobaud).

For the autobaud function, after a successful detection, the baud rate parameter (C9.8.3) automatically changes to the detected rate. To run the autobaud function again, it is necessary to change the parameter C9.8.3 to one of the autobaud options.

Indication	Description
0 = 1 Mbps/Auto	CAN baud rate (automatic detection for DeviceNet).
1 = Reserved/Auto	Automatic detection for DeviceNet.
2 = 500 Kbps	CAN baud rate.
3 = 250 Kbps	CAN baud rate.
4 = 125 Kbps	CAN baud rate.
5 = 100 Kbps/Auto	CAN baud rate (automatic detection for DeviceNet).

NOTE!

After changing this configuration, the modification will only take effect if the CAN interface is not exchanging cyclical data with the network.

C9.8 CAN/CANopen/DNet
C9.8.4 Bus Off Reset

Range: 0 ... 1 **Default:** 0
Properties: Stopped

Description:

It allows programming the behavior of the equipment when detecting a bus off error on the CAN interface.

Indication	Description
0 = Manual	If bus off occurs, A134/F234 will be displayed on the HMI and the communication will be disabled. In case of alarm, the action programmed in parameter C9.1.2.2 will be executed. For the equipment to communicate again via CAN interface, it will be necessary to disable and enable the interface, or restart the product.
1 = Automatic	If bus off occurs, the communication will be automatically restarted, and the error will be ignored. In this case the alarm will not be displayed on the HMI and the device will not execute the action described in C9.1.2.2.

C9.8 CAN/CANopen/DNet
C9.8.5 DeviceNet I/O Instances

Range: 0 ... 10 **Default:** 0
Properties: Stopped

Description:

It allows selecting the Assembly class instance used during the exchange of I/O data with the network master.

The CFW900 frequency inverter has eleven setting options. Four of them follow the standard defined in the ODVA AC/DC Drive Profile. The others represent specific words for the CFW900 frequency inverter. The table below detail each of these control and status words.

Indication	Description
0 = 20/70 CIP	Basic Speed, these instances represent the simplest operation interface of a device according to the AC/DC Drive Profile
1 = 21/71 CIP	Extended Speed, these instances represent a slightly improved interface for operating the device that follows the AC/DC Device Profile
2 ... 3 = Not used	Not used.
4 = 120/170 CIP + I/O data	They have the same data format as the 20/70 CIP Basic Speed Control instances. In addition, it is possible to program up to 48 parameters of the equipment itself for reading and/or 48 for writing via network
5 = 121/171 CIP + I/O data	They have the same data format as the 21/71 CIP Extended Speed Control instances. In addition, it is possible to program up to 48 parameters of the device itself for reading and/or 48 for writing via network
6 ... 7 = Not used	Not used.
8 = 100/150 Manuf. + I/O data	These instances represent the operating interface of the device according to the CFW900 frequency inverter profile. Besides the control and status words, speed reference and effective value, it is possible to program up to 48 parameters of the device itself for reading and/or writing via network
9 = 101/151 Manuf. + I/O data	These instances represent an interface very similar to the 100/150 Manufacturer Speed Control + configurable I/O data, with the only difference being the possibility of sending the torque limit
10 = 102/152 Config I/O data	In these instances it is possible to program up to 50 parameters of the equipment itself for reading and/or 50 for writing via network

NOTE!

After changing this configuration, the modification will only take effect if the CAN interface is not exchanging cyclical data with the network.

C9.8 CAN/CANopen/DNet
C9.8.6 DNet Reading 1st Word

Range: 1 ... 100

Default: 1

Properties: Stopped

Description:

It sets the index of the first programmable reading word for data exchange with the network (input to the network master).

C9.8 CAN/CANopen/DNet
C9.8.7 DNet Reading Quantity

Range: 0 ... 50

Default: 0

Properties: Stopped

Description:

It sets the number of programmable reading words for data exchange with the network (input to the network master), from the first configured word.

C9.8 CAN/CANopen/DNet
C9.8.8 DNet Writing 1st Word

Range: 1 ... 100

Default: 1

Properties: Stopped

Description:

It sets the index of the first programmable writing word for data exchange with the network (output to the network master).

C9.8 CAN/CANopen/DNet
C9.8.9 DNet Writing Quantity

Range: 0 ... 50

Default: 0

Properties: Stopped

Description:

It sets the number of programmable writing words for data exchange with the network (output to the network master), from the first configured word.

The mappings of the drive's control and monitoring words are presented below.

C9.8.5 = 0, 20/70 CIP Basic Speed (2 words):

Status (Input)

Instance	Byte	Bit 7	Bit 6	Bit 5	Bit 4	Bit 3	Bit 2	Bit 1	Bit 0
70	0						Running1		Faulted
	1	-							
	2	Speed Actual (low byte)							
	3	Speed Actual (high byte)							

Control (Output)

Instance	Byte	Bit 7	Bit 6	Bit 5	Bit 4	Bit 3	Bit 2	Bit 1	Bit 0
20	0						Fault Reset		Run Fwd
	1	-							
	2	Speed Reference (low byte)							
	3	Speed Reference (high byte)							

C9.8.5 = 1, 21/71 CIP Extended Speed (2 words):

Status (Input)

Instance	Byte	Bit 7	Bit 6	Bit 5	Bit 4	Bit 3	Bit 2	Bit 1	Bit 0
71	0	At Reference	Ref. from Net	Ctrl from Net	Ready	Running2 (Rev)	Running1 (Fwd)	Warning	Faulted
	1	Drive State							
	2	Speed Actual (low byte)							
	3	Speed Actual (high byte)							

Control (Output)

Instance	Byte	Bit 7	Bit 6	Bit 5	Bit 4	Bit 3	Bit 2	Bit 1	Bit 0
21	0		NetRef	NetCtrl			Fault Reset	Run Rev	Run Fwd
	1	-							
	2	Speed Reference (low byte)							
	3	Speed Reference (high byte)							

The following tables present the meaning of the data for instances 20/70 and 21/71.

Status

Bit	Value/Description
Bit 0 Faulted	0: frequency inverter is not in a fault condition 1: a fault has been recorded by the frequency inverter
Bit 1 Warning	0: frequency inverter is not in alarm condition 1: frequency inverter is in alarm condition
Bit 2 Running1 (Fwd)	0: motor is not rotating clockwise 1: motor is rotating clockwise
Bit 3 Running2 (Rev)	0: motor is not rotating counterclockwise 1: motor is rotating counterclockwise
Bit 4 Ready	0: frequency inverter is not ready to operate 1: frequency inverter is ready to operate (states Ready, Enabled or Stopping)
Bit 5 Ctrl from Net	0: drive is controlled locally 1: drive is controlled remotely
Bit 6 Ref. from Net	0: speed reference is not being sent via the DeviceNet network 1: indicates that the speed reference is being sent via the DeviceNet network
Bit 7 At Reference	0: frequency inverter has not yet reached the programmed speed 1: frequency inverter has reached the programmed speed

- Byte 1 indicates the drive status:
 - 0 = Non Existent
 - 1 = Startup
 - 2 = Not Ready
 - 3 = Ready
 - 4 = Enabled
 - 5 = Stopping
 - 6 = Fault Stop
 - 7 = Faulted
- Bytes 2 (low) and 3 (high) represent the actual motor speed in rpm.

Control

Bit	Value/Description
Bit 0 Run Fwd	0: it stops the motor 1: it runs the motor clockwise
Bit 1 Run Rev	0: it stops the motor 1: it runs the motor counterclockwise
Bit 2 Fault Reset	0: no function 1: if in a fault condition, then it executes the inverter reset
Bits 3 and 4	Reserved
Bit 5 NetCtrl	0: it selects the local mode 1: it selects the remote mode
Bit 6 NetRef	0: speed reference is not being sent via network 1: speed reference being sent via the network
Bits 7	Reserved

- Bytes 2 (low) and 3 (high) represent motor speed setpoint in rpm.

C9.8.5 = 4, 120/170 CIP Basic Speed (2 words) + I/O data (up to 48 words):

It has the same semantics as the instances of the 20/70 class but with the possibility of programming up to 48 reading words (C9.8.6 and C9.8.7) and/or 48 drive writing words (C9.8.8 and C9.8.9).

Status

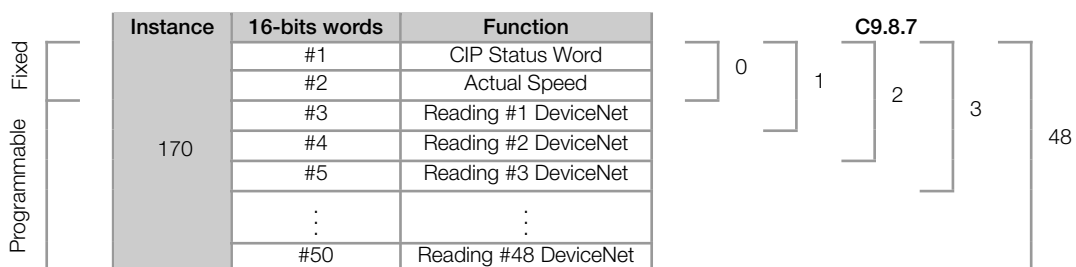

Control

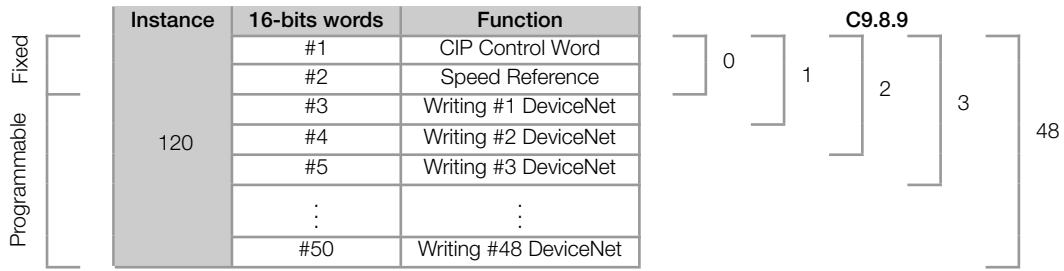

C9.8.5 = 5, 121/171 CIP Extended Speed (2 words) + I/O data (up to 48 words):

It has the same semantics as the instances of the 21/71 class but with the possibility of programming up to 48 reading words (C9.8.6 and C9.8.7) and/or 48 drive writing words (C9.8.8 and C9.8.9).

Status

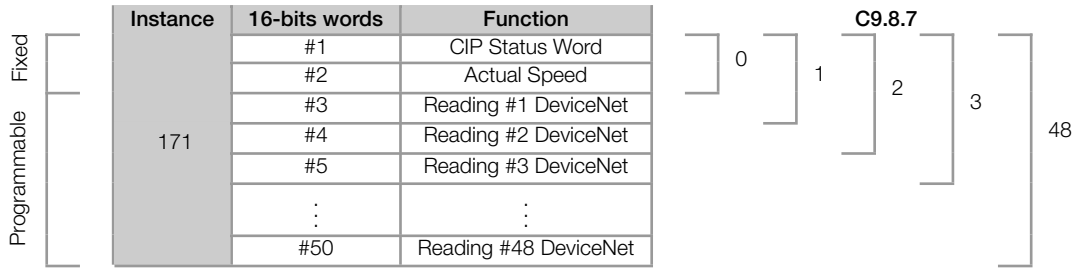

Control

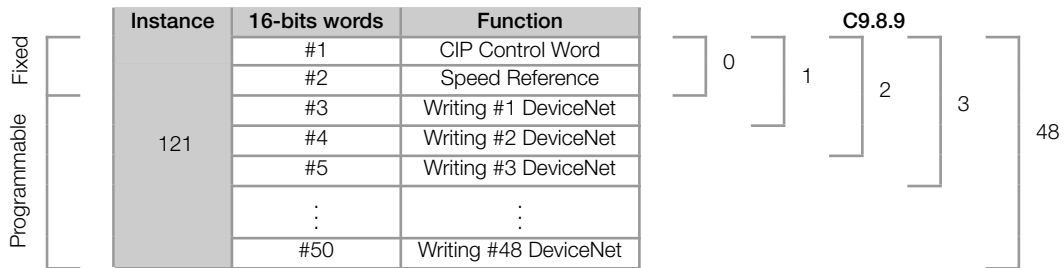

C9.8.5 = 8, 100/150 CIP Manufacturer Speed (2 words) + I/O data (up to 48 words):

Status (Input)

Bit	15	14	13	12	11	10	9	8	7	6	5	4	3	2	1	0
Function	Fault	Not Used	Undervoltage	Remote 2	JOG	Reverse	Enabled	Running	Alarm	Config. Mode	2nd Ramp	No Quick Stop	Not Used	Local	Run Command	STO

Control (Output)

Bit	15	14	13	12	11	10	9	8	7	6	5	4	3	2	1	0
Function	Reserved								Fault Reset	No Quick Stop	2nd Ramp	R1/R2 Mode	Enable JOG	Turn Reverse	General Enable	Enable Ramp

Status

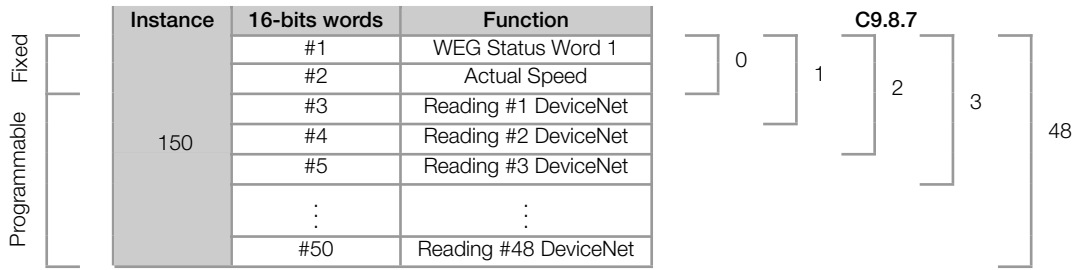

Control

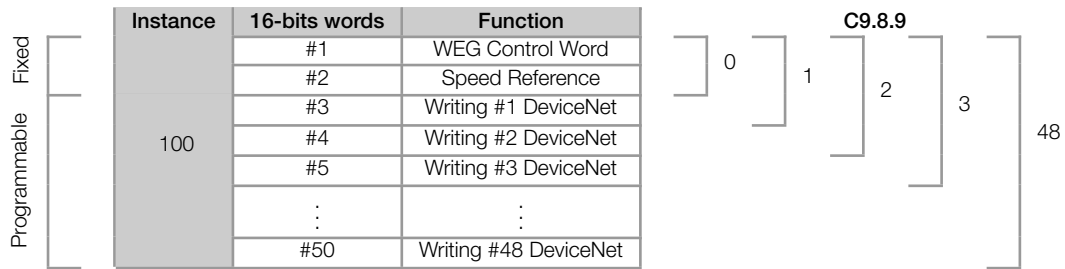

C9.8.5 = 9, 101/151 CIP Manufacturer Speed and Torque (3 words) + I/O data (up to 47 words):

Status (Input)

Bit	15	14	13	12	11	10	9	8	7	6	5	4	3	2	1	0
Function	Fault	Not Used	Undervoltage	Remote 2	JOG	Reverse	Enabled	Running	Alarm	Config. Mode	2nd Ramp	No Quick Stop	Not Used	Local	Run Command	STO

Control (Output)

Bit	15	14	13	12	11	10	9	8	7	6	5	4	3	2	1	0
Function	Reserved								Fault Reset	No Quick Stop	2nd Ramp	R1/R2 Mode	Enable JOG	Turn Reverse	General Enable	Enable Ramp

Status

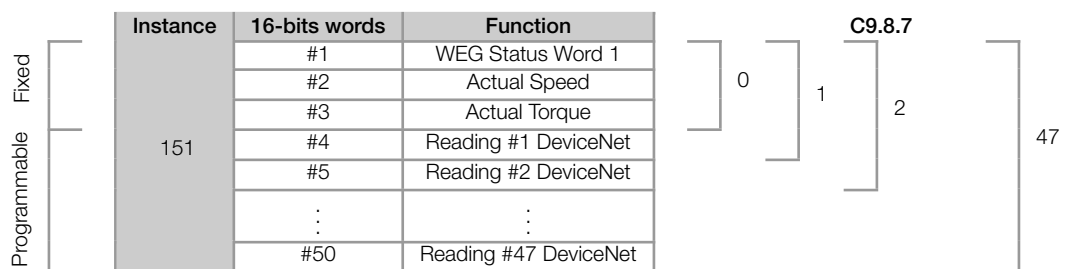

Control

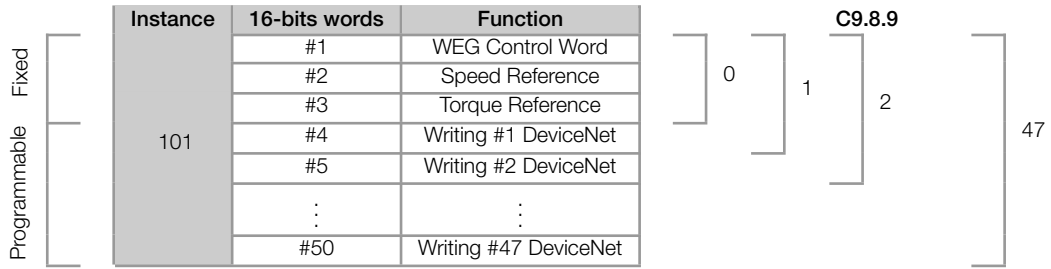

C9.8.5 = 10, 102/152 CIP Configurable I/O data (up to 50 words):

This instance is completely open and allows the user to program any equipment parameter up to the limit of 50 reading words (C9.8.6 and C9.8.7) and/or 50 writing words (C9.8.8 and C9.8.9).

Status

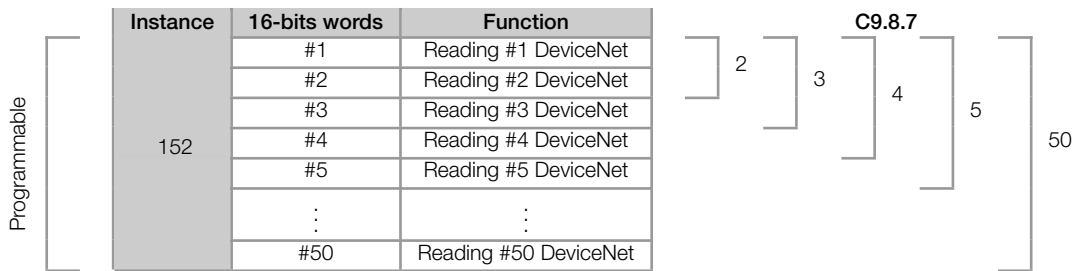

Control

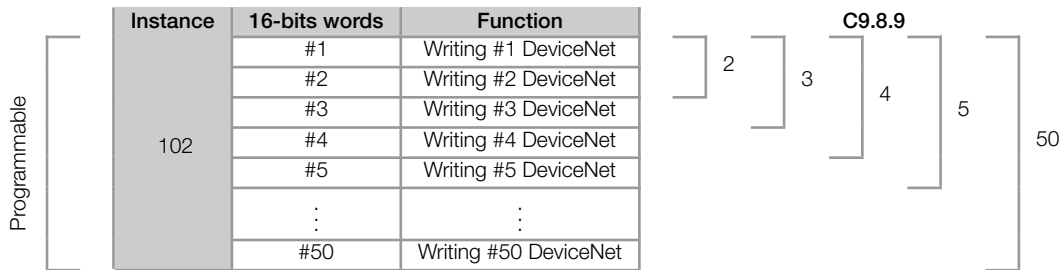

6 OPERATION IN THE DEVICENET NETWORK

6.1 CYCLIC DATA

Cyclic data is the data normally used for status monitoring and equipment control. For DeviceNet protocol, the interface supports an I/O connection that allows communication up to 50 input words and 50 output words.

It is necessary the configuration to be made both at the slave and master, i.e., the same amount of input words and output words must be set in the CFW900 and in the master.

I/O connections have different formats, called I/O instances. One of these instances must be selected by the user through parameter C9.8.5. For the following examples, we suppose C9.8.5 CAN/CANopen/DNet DeviceNet I/O Instances is equal to 102/152 Config I/O data.

6.1.1 Input words

The CFW900 frequency inverter has a reading area with 100 16-bits words available for cyclic data exchange of communication networks. The data available in the reading area (input) is sent to the network master. This area is shared by all communication protocols.

To map an object in the reading area, follow the steps below.

1. Configure parameter C9.8.6. This parameter indicate which of the reading words starts the input area.
2. Configure on parameter C9.8.7 the quantity of input words which must be transmitted via network.
3. Parameters C9.2.1.1 até C9.2.1.100 enable to configure the data that must be provided on the reading words. Those parameters must contain the network addresses (Net Id) of the data that must be transmitted on the respective reading words. The Net Id list is available on the table 10.1. Consider the size of each parameter mentioned in this list when programming each word.

Example

The example below presents a configuration for DeviceNet considering the following parameters to be mapped:

- S5.1.1 Status and Commands Status Word 1.
- S5.1.3 Status and Commands Status Word 2.
- S5.1.2 Status and Commands Speed.
- S2.3.1 Inverter Output Current.

Searching for parameter information on the table 10.1:

Mapped Parameter	Net Id	Size	Qty Mapped Words	Example Value
S5.1.1 Status and Commands Status Word 1	680	16bit	1	786 = 0312h
S5.1.3 Status and Commands Status Word 2	690	16bit	1	33288 = 8208h
S5.1.2 Status and Commands Speed	681	16bit	1	6500 (65.00 %)
S2.3.1 Inverter Output Current	3	16bit	1	23 (2.3 A)

Therefore, the configuration must be performed as shown below:

1. C9.8.6 CAN/CANopen/DNet DNet Reading 1st Word = 26 → first transmitted word via network is word #26.
2. C9.8.7 CAN/CANopen/DNet DNet Reading Quantity = 4 → sum of column “Qty mapped words”.

3. Table 6.1 presents the configuration parameters of the words and the content of the reading words.

Table 6.1: Example of reading words configuration.

Configuration Parameter	Mapped Parameter	Net Id	Input Area Value
C9.2.1.26 Reading Data Word #26	S5.1.1	680	0312h
C9.2.1.27 Reading Data Word #27	S5.1.3	690	8208h
C9.2.1.28 Reading Data Word #28	S5.1.2	681	1964h
C9.2.1.29 Reading Data Word #29	S2.3.1	3	0017h



NOTE!

- Mapping of invalid parameters or not available will return zero value.
- The data is transmitted as an integer value, without the indication of the decimal places.
- To obtain the network address (Net Id) of the parameters and the number of decimal places, refer to the item 10.

6.1.2 Output Words

The CFW900 frequency inverter has a writing area with 50 16-bits words available for cyclic data exchange of communication networks. The data available in the write area (output) is received from the network master. This area is shared by all communication protocols.

To map an object in the writing area, follow the steps below.

1. Configure parameter C9.8.8. This parameter indicate which of the writing words starts the output area.
2. Configure on parameter C9.8.9 the quantity of writing words which must be transmitted via network.
3. Parameters C9.2.2.2 to C9.2.2.101 enable to configure the data that must be provided on the writing words. Those parameters must contain the network address (Net Id) of the data that must be transmitted on the respective writing words. The Net Id list is available on the table 10.1. Consider the size of each parameter mentioned in list when programming each word.

Exemplo

The example below presents a configuration for DeviceNet considering the following parameters to be mapped:

- S5.7.2 CAN/CANopen/DNet Control Word.
- S5.7.3 CAN/CANopen/DNet Speed Reference.
- C6.1.1 Speed Control Ramps Acceleration Time.

Searching parameter information on the table 10.1:

Mapped Parameter	Net Id	Size	Qty Mapped Words	Example Value
S5.7.2 CAN/CANopen/DNet Control Word	684	16bit	1	83 = 0053h
S5.7.3 CAN/CANopen/DNet Speed Reference	685	16bit	1	2500 (25.00) = 9C4h
C6.1.1 Speed Control Ramps Acceleration Time	100	16bit	1	100 (10.0) = 0064h

Therefore, the configuration must be performed as shown below:

1. C9.8.8 CAN/CANopen/DNet DNet Writing 1st Word = 1 → first word transmitted via network is the word #1.

2. C9.8.9 CAN/CANopen/DNet DNet Writing Quantity = 3 → sum of column “Qty mapped words”.
3. The table 6.2 presents the configuration parameters of the words and the content of the writing words.

Table 6.2: Example of configuration of the writing words.

Configuration Parameter	Mapped Parameter	Net Id	Output Area Value
C9.2.2.2 Writing Data Word #1	S5.7.2	684	0053h
C9.2.2.3 Writing Data Word #2	S5.7.3	685	9C4h
C9.2.2.4 Writing Data Word #3	C6.1.1	100	0064h



NOTE!

- Mapping of readonly parameters (status, diagnostics) or invalid parameters will have no effect.
- Parameters that have the property *Stopped*, when mapped on the writing words, are only changed when the motor is stopped.
- The parameters written using these words are not saved in non-volatile memory. Thus, if the equipment is turned off and back on, these parameters will return to their original value.
- The data is transmitted as an integer value, without the indication of the decimal places.
- To obtain the network address (Net Id) of the parameters, refer to the item 10.

6.2 ACYCLIC DATA

In addition to the cyclic data, the interface also provides acyclic data via explicit messaging. Using this type of communication, you can access any equipment parameter. Access to this type of data is commonly done using instructions for reading or writing data, which should indicate the class, instance, and attribute to the desired parameter. The Manufacturer Specific Classes (64h, 65h and 66h) describe how to address the parameters for CFW900 frequency inverter.

6.3 EDS FILE

Each device on an DeviceNet network has an EDS configuration file, which contains information about the device functions on the network. This file is used by a master or configuration software to program devices present at DeviceNet network.

The EDS file is available from WEG website (<http://www.weg.net>). It is important to note if the EDS configuration file is compatible with the firmware version of the CFW900 frequency inverter.

6.4 SUPPORTED OBJECT CLASSES

Any DeviceNet equipment is modeled as a set of objects. The objects are responsible for defining the function that each device will have. In other words, depending on the objects the device implements, it may be a communication adapter, an AC/DC drive, a photoelectric sensor, etc. Mandatory and optional objects are defined for each Device Profile. The CFW900 frequency inverter supports all mandatory classes defined for the AC/DC Device Profile. It also supports Manufacturer Specific classes. The following sections present detailed information about these object classes.

6.4.1 Identity Class (01h)

Provides general information about the device identity such as VendorID, Product Name, Serial Number, etc.. The following attributes are implemented:

Table 6.3: Identity Class instance attributes

Attribute	Method	Name	Default	Description
1	GET	Vendor ID	355h	Manufacturer identifier
2	GET	Device Type	2Bh	Product Type
3	GET	Product Code	1700h	Product Code
4	GET	Revision	According to the equipment firmware version	Firmware revision
5	GET	Status		Device status
6	GET	Serial Number	Different for each CFW900	Serial Number
7	GET	Product Name	CFW900	Product name

6.4.2 Message Router Class (02h)

Provides information on the explicit message router object. This class does not have any attribute implemented in the CFW900.

6.4.3 DeviceNet Class (03h)

This class is responsible for maintaining the configuration and the state of the physical connections of the DeviceNet node. The following attributes are implemented:

Table 6.4: DeviceNet Class attributes

Atributte	Method	Name	Min/Max	Default	Description
1	GET	Revision	1 - 65535		Revision of the DeviceNet Object Class definition upon which the implementation is based

Table 6.5: DeviceNet Class instance attributes

Atributte	Method	Name	Min/Max	Default	Description
1	GET/SET	MAC ID	0 - 63	63	Node address
2	GET/SET	Baud Rate	0 - 2	0	Communication baud rate
3	GET/SET	Bus-Off Interrupt	0 - 1	1	Bus-off reset
4	GET/SET	Bus-Off Counter	0 - 255		Bus-off counter
5	GET	Allocation Information			Information about allocation byte

6.4.4 Assembly Class (04h)

This class is responsible for grouping several attributes in only one connection. Only the attribute Data (3) is implemented in the CFW900.

Table 6.6: Assembly class instance attributes

Atributte	Method	Name	Description
3	GET	Data	Data contained in the assembly object

The Assembly class contains the following instances in the CFW900:

Table 6.7: *Assembly class instances*

Instance	Size	Description
100	2 bytes	Producing Instance
101	4 bytes	Producing Instance
...	...	Producing Instance
149	100 bytes	Producing Instance
150	2 bytes	Consuming Instance
151	4 bytes	Consuming Instance
...	...	Consuming Instance
199	100 bytes	Consuming Instance

6.4.5 Connection Class (05h)

This class allocates and manages the internal resources associated with both I/O and Explicit Messaging connections. The following attributes are implemented:

6.4.5.1 Instance 1: Explicit Message

Table 6.8: *Connection Class – Instance 1: Explicit Message*

Attribute	Method	Name	Description
1	GET	State	Object state
2	GET	Instance Type	I/O or explicit
3	GET	Transport Class trigger	Defines the connection behavior
4	GET	Produced Connection ID	ID field for transmission
5	GET	Consumed Connection ID	ID field value representing received msg
6	GET	Initial Comm. Charac.	Defines message groups related to this connection
7	GET	Produced Connection Size	Maximum size (bytes) of this transmission connection
8	GET	Consumed Connection Size	Maximum size (bytes) of this reception connection
9	GET/SET	Expected Packet Rate	Defines timing associated to this connection
12	GET/SET	Watchdog Timeout Action	Action for inactivity/watchdog timeout
13	GET	Produced Connection Path Length	Number of bytes in the producer connection
14	GET	Produced Connection Path	Specifies the path of the data producer objects
15	GET	Consumed Connection Path Length	Number of bytes in the consumer connection
16	GET	Consumed Connection Path	Specifies the path of the data consumer objects
17	GET	Production Inhibit Time	Defines the minimum time between new data production
18	GET/SET	Connection Timeout Multiplier	

6.4.5.2 Instance 2: Polled

Table 6.9: Connection Class – Instance 2: Polled

Attribute	Method	Name	Description
1	GET	State	Object state
2	GET	Instance Type	I/O or explicit
3	GET	Transport Class trigger	Defines the connection behavior
4	GET	Produced Connection ID	ID field for transmission
5	GET	Consumed Connection ID	ID field value representing received msg
6	GET	Initial Comm. Charac.	Defines message groups related to this connection
7	GET	Produced Connection Size	Maximum size (bytes) of this transmission connection
8	GET	Consumed Connection Size	Maximum size (bytes) of this reception connection
9	GET/SET	Expected Packet Rate	Defines timing associated to this connection
12	GET	Watchdog Timeout Action	Action for inactivity/watchdog timeout
13	GET	Produced Connection Path Length	Number of bytes in the producer connection
14	GET	Produced Connection Path	Specifies the path of the data producer objects
15	GET	Consumed Connection Path Length	Number of bytes in the consumer connection
16	GET	Consumed Connection Path	Specifies the path of the data consumer objects
17	GET	Production Inhibit Time	Defines the minimum time between new data production
18	GET/SET	Connection Timeout Multiplier	

6.4.5.3 Instance 4: Change of State/Cyclic

Table 6.10: Connection Class – Instance 4: Change of State/Cyclic

Attribute	Method	Name	Description
1	GET	State	Object state
2	GET	Instance Type	I/O or explicit
3	GET	Transport Class trigger	Defines the connection behavior
4	GET	Produced Connection ID	ID field for transmission
5	GET	Consumed Connection ID	ID field value representing received msg
6	GET	Initial Comm. Charac.	Defines message groups related to this connection
7	GET	Produced Connection Size	Maximum size (bytes) of this transmission connection
8	GET	Consumed Connection Size	Maximum size (bytes) of this reception connection
9	GET/SET	Expected Packet Rate	Defines timing associated to this connection
12	GET	Watchdog Timeout Action	Action for inactivity/watchdog timeout
13	GET	Produced Connection Path Length	Number of bytes in the producer connection
14	GET	Produced Connection Path	Specifies the path of the data producer objects
15	GET	Consumed Connection Path Length	Number of bytes in the consumer connection
16	GET	Consumed Connection Path	Specifies the path of the data consumer objects
17	GET	Production Inhibit Time	Defines the minimum time between new data production
18	GET/SET	Connection Timeout Multiplier	

6.4.6 Motor Data Class (28h)

This class stores the information on the motor connected to the product. The following attributes have been implemented:

Table 6.11: Motor Data Class attributes

Attribute	Method	Name	Min/Max	Description
1	GET	Revision	1 - 65535	Revision of the Motor Data Object Class Definition upon which the implementation is based
2	GET	Max Instance	1 - 65535	Maximum instance number

Table 6.12: Motor Data Class instance attributes

Attribute	Method	Name	Min/Max	Unit	Default	Description
3	GET	Motor Type	0 - 10	-	7	0 = Non Standard Motor 1 = PM DC Motor 2 = FC DC Motor 3 = PM Synchronous Motor 4 = FC Synchronous Motor 5 = Switched Reluctance Motor 6 = Wound Rotor Induction Motor 7 = Squirrel Cage Induction Motor 8 = Stepper Motor 9 = Sinusoidal PM BL Motor 10 = Trapezoidal PM BL Motor
6	GET/SET	Rated Current	0-999.9	100mA		Nominal current
7	GET/SET	rated Voltage	0-600	V		Nominal voltage

6.4.7 Control Supervisor Class (29h)

Responsible for modeling the drive management functions. The following attributes have been implemented:

Table 6.13: Control Supervisor Class attributes

Attribute	Method	Name	Min/Max	Description
1	GET	Revision	1 - 65535	Revision of the Control Supervisor Object Class Definition upon which the implementation is based
2	GET	Max Instance	1 - 65535	Maximum instance number

Table 6.14: Control Supervisor Class instance attributes

Attribute	Method	Name	Min/Max	Default	Description
3	GET/SET	Run 1	0 - 1	-	Run Fwd
4	GET/SET	Run 2	0 - 1	-	Run Rev
5	GET/SET	NetCtrl	0 - 1	0	0 = Local control 1 = Remote control
6	GET	State	0 - 7	-	0 = Vendor specific 1 = Startup 2 = Not Ready 3 = Ready 4 = Enable 5 = Stopping 6 = Fault Stop 7 = Fault
7	GET	Running 1	0 - 1	0	0 = Other state 1 = (Enabled and Run1) or (Stopping and Running1) or (Fault Stop and Running1)
8	GET	Running 2	0 - 1	0	0 = Other state 1 = (Enabled and Run2) or (Stopping and Running2) or (Fault Stop and Running2)
9	GET	Ready	0 - 1	0	0 = Other state 1 = Ready or Enabled or Stopping
10	GET	Faulted	0 - 1	0	0 = No error 1 = Error
11	GET	Warning	0 - 1	0	0 = No warnings
12	GET/SET	Fault Reset	0 - 1	0	0 = No action 0 -> 1 = Error reset
15	GET	Ctrl from Net	0 - 1	0	0 = Local control 1 = Remote control

6.4.8 AC/DC Drive Class (2Ah)

Contains specific information of an AC/DC Drive such as operation mode, speed and torque ranges. The following attributes have been implemented:

Table 6.15: AC/DC Drive Class attributes

Attribute	Method	Name	Min/Max	Description
1	GET	Revision	1 - 65535	Revision of the AC/DC Drive Object Class Definition upon which the implementation is based
2	GET	Max Instance	1 - 65535	Maximum instance number

Table 6.16: AC/DC Drive Class instance attributes

Attribute	Method	Name	Min/Max	Default	Description
4	GET/SET	NetRef 2	0 - 1	0	0 = Local reference 1 = Remote reference
6	GET	DriveMode	1 - 2	-	1 = Speed control (open loop) 2 = Speed control (closed loop)
7	GET	Speed Actual	0 - 9999		Actual speed (best approximation)
8	GET/SET	Speed Ref	0 - 9999	0	Speed reference



NOTE!

The CFW900 will work in speed mode independently of the content of the DriveMode attribute.

6.4.9 Acknowledge Handler Class (2Bh)

This class is responsible for managing the reception of acknowledgment messages.

Table 6.17: Acknowledge Handler Class instance attributes

Attribute	Method	Name
1	GET/SET	Acknowledge Timer
2	GET/SET	Retry Limit
3	GET	COS Production Connection Instance

6.4.10 Manufacturer Specific Classes (64h, 65h and 66h)

The Manufacturer Specific Classes are used for mapping all CFW900 parameters. This classes allow the user to read from and write to any parameter through the network. The Manufacturer Specific Class use DeviceNet explicit messages.



NOTE!

- The data is transmitted as an integer value, without the indication of the decimal places.
- To obtain the class, instance and attribute of each parameter, refer to the item 10.

7 STARTUP GUIDE

The main steps to start up the CFW900 frequency inverter in DeviceNet network are described below. These steps represent an example of use. Check out the specific chapters for details on the indicated steps.

7.1 INSTALLING THE ACCESSORY

1. Install the communication accessory, as indicated in the installation guide supplied with the accessory.
2. Connect the cable to the accessory, considering the recommended instructions in network installation, as described in item 3.5:
 - Use shielded cable.
 - Properly ground network equipment.
 - Avoid laying communication cables next to power cables.

7.2 CONFIGURING THE EQUIPMENT

1. Follow the recommendations described in the user manual to program the device parameters related to the motor parameterization, desired functions for the I/O signals, etc.
2. Program the command sources as desired for the application in menu C4.
3. Configure communication parameters, such as address and baudrate in C9.8.
4. Program the desired action for the equipment in case of communication fault in C9.1.
5. Define which data will be read and written at frequency inverter CFW900 using menu C9.2. Among the main parameters that can be used to control the device, we can mention:
 - S5.1.1 Status and Commands Status Word 1 (read)
 - S5.1.3 Status and Commands Status Word 2 (read)
 - S5.7.2 CAN/CANopen/DNet Control Word (write)

7.3 CONFIGURING THE MASTER

The way the network configuration is done depends greatly on the used client and the configuration tool. It is essential to know the tools used to perform this activity. In general, the following steps are necessary to perform the network configuration.

1. Load the EDS file¹ to the list of devices in the network configuration tool.
2. Select CFW900 frequency inverter from the available list of devices on the network configuration tool. This can be done manually or automatically, if allowed by the tool.
3. During the configuration of the network, it is necessary to define the quantity of I/O data communicated between master and slave, as well as the transmission method of these data. The DeviceNet protocol defines different methods of data exchange, seeing that the module supports the following methods:

Polled: communication method in which the master sends a telegram to each of the slaves of its list (*scan list*). As soon as it receives the request, the slave immediately answers the request of the master. This process is repeated until all slaves are polled, restarting the cycle.

Change of State: communication method in which the data exchange between master and slave only occurs when there are changes in the values monitored/controlled up to a certain time limit. When this limit is reached, the transmission and reception will take place even if changes have not occurred.

¹The EDS file is available from WEG website (<http://www.weg.net>). It is important to note if the EDS configuration file is compatible with the firmware version of the CFW900 frequency inverter.

Cyclic: another communication method very similar to the previous one. The only difference is the production and consumption of messages. In this type of communication, every data exchange occurs at regular time intervals, no matter if they have been changed or not.

Once configured, the network status S5.7.11 indicates Online Connected and the master status S5.7.12 indicates Run. It is in this condition that cyclic data exchange effectively occurs between the slave and the master of the network.

7.4 COMMUNICATION STATUS

Once the network is assembled and the client programmed, it is possible to use the MS LED and parameters of the equipment to identify some status related to the communication.

- The parameters S5.7.11 and S5.7.12 indicate the status of communication between the device and the network master.

The master of the network must also supply information about the communication with the slave.

7.5 OPERATION USING PROCESS DATA

Once the communication is established, the data mapped in the I/O area is automatically updated between master and slave. Among the main parameters that can be used to control the device, we can mention:

- S5.1.1 Status and Commands Status Word 1 (read)
- S5.1.3 Status and Commands Status Word 2 (read)
- S5.7.2 CAN/CANopen/DNet Control Word (write)

It is important to know these parameters to program the master as desired for the application.

7.6 ACCESS TO PARAMETERS – ACYCLIC MESSAGES

Besides the I/O data (cyclic) communication, the DeviceNet protocol also defines a kind of acyclic telegram (*explicit messages*), used especially in asynchronous tasks, such as parameter setting and configuration of the equipment.

The EDS file provides the full parameter list of the equipment, which can be accessed via *explicit messages*. The item 6.2 how to address the parameters of the frequency inverter CFW900 via acyclic messages.

8 FAULTS AND ALARMS

Fault/Alarm	Description	Possible Causes
A133: No Power Supply on the CAN Interface	It actuates when the CAN interface is powered and lack of power supply to the interface is detected. Note: - Measure if there is voltage within the allowed range between pins 1 and 5 of the CAN interface connector.	<ul style="list-style-type: none"> - CAN interface without power supply between pins 1 and 5 of the connector. - Power cables mixed up or reversed. - Poor contact on the CAN interface cable or connector.
A134: Bus Off	Bus off error detection on the CAN interface. If the number of reception or transmission errors detected by the CAN interface is too high, the CAN controller can be taken to the bus off state, where it interrupts the communication and disables the CAN interface. In order to restore communication, it is necessary to turn the product off and on again, or to remove and reconnect the power to the CAN interface, so that communication can be restarted.	<ul style="list-style-type: none"> - Short circuit in the CAN circuit transmission cables. - Changed or reversed cables. - Network devices with different baud rates. - Termination resistors with incorrect values. - Termination resistors installed at one end of the main bus only. - CAN network installation done improperly.
A136: Master in Idle	It actuates when communicating with the network master in Run mode, and transition to Idle mode is detected	<ul style="list-style-type: none"> - Set the switch that controls the master operation of the master to Run or the corresponding bit on the configuration word of the master software. For further explanations, see the documentation of the master in use.
A137: DeviceNet connection timeout	It indicates that one or more DeviceNet I/O connections has expired. It occurs when the cyclic communication between the master and the product is interrupted.	<ul style="list-style-type: none"> - Check the status of the network master. - Check the network installation, broken cable or poor contact on the connections with the network.
F233: No Power Supply on the CAN Interface	It actuates when the CAN interface is powered and lack of power supply to the interface is detected. Note: - Measure if there is voltage within the allowed range between pins 1 and 5 of the CAN interface connector.	<ul style="list-style-type: none"> - CAN interface without power supply between pins 1 and 5 of the connector. - Power cables mixed up or reversed. - Poor contact on the CAN interface cable or connector.
F234: Bus Off	Bus off error detection on the CAN interface. If the number of reception or transmission errors detected by the CAN interface is too high, the CAN controller can be taken to the bus off state, where it interrupts the communication and disables the CAN interface. In order to restore communication, it is necessary to turn the product off and on again, or to remove and reconnect the power to the CAN interface, so that communication can be restarted.	<ul style="list-style-type: none"> - Short circuit in the CAN circuit transmission cables. - Changed or reversed cables. - Network devices with different baud rates. - Termination resistors with incorrect values. - Termination resistors installed at one end of the main bus only. - CAN network installation done improperly.
F236: Master in Idle	It actuates when communicating with the network master in Run mode, and transition to Idle mode is detected	<ul style="list-style-type: none"> - Set the switch that controls the master operation of the master to Run or the corresponding bit on the configuration word of the master software. For further explanations, see the documentation of the master in use.
F237: DeviceNet Connection Timeout	It indicates that one or more DeviceNet I/O connections has expired. It occurs when the cyclic communication between the master and the product is interrupted.	<ul style="list-style-type: none"> - Check the status of the network master. - Check the network installation, broken cable or poor contact on the connections with the network.

9 PARAMETER STRUCTURE

S Status

- └ S1 Inverter
 - └ S1.1 Status
 - └ S1.2 Software Version
 - └ S1.2.2 Details
 - └ S1.3 Inverter Data
 - └ S1.4 Control Accessory Data
 - └ S1.4.1 Backplane
 - └ S1.4.2 Slot A
 - └ S1.4.3 Slot B
 - └ S1.4.4 Slot C
 - └ S1.4.5 Slot D
 - └ S1.4.6 Slot E
 - └ S1.4.7 Slot F
 - └ S1.4.8 Slot G
 - └ S1.5 Date/Hour
 - └ S1.6 Control Words
- └ S2 Measurements
 - └ S2.1 Motor Speed
 - └ S2.2 Motor Torque
 - └ S2.3 Inverter Output
 - └ S2.4 Motor Temperatures
 - └ S2.5 Inverter Temperatures
 - └ S2.5.1 IGBT Temperature
 - └ S2.5.3 Internal Air Temperature
 - └ S2.7 DC Link
 - └ S2.8 Torque Current Limitation
- └ S3 I/Os
 - └ S3.1 Slot X Status
 - └ S3.1.1 Analog Inputs
 - └ S3.1.2 Analog Outputs
 - └ S3.1.3 Digital Inputs
 - └ S3.1.4 Digital Outputs
 - └ S3.1.5 Encoder
 - └ S3.2 Slot A Status
 - └ S3.2.1 Analog Inputs
 - └ S3.2.2 Analog Outputs
 - └ S3.2.3 Digital Inputs
 - └ S3.2.4 Digital Outputs
 - └ S3.2.5 Encoder
 - └ S3.2.6 Temperatures
 - └ S3.3 Slot B Status
 - └ S3.4 Slot C Status
 - └ S3.5 Slot D Status

S Status (cont.)

- └ S3 I/Os (cont.)
 - └ S3.6 Slot E Status
 - └ S3.7 Slot F Status
 - └ S3.8 Slot G Status
- └ S4 Functional Safety
- └ S5 Communications
 - └ S5.1 Status and Commands
 - └ S5.2 Serial RS485
 - └ S5.3 Ethernet
 - └ S5.4 EtherNet/IP
 - └ S5.5 Modbus TCP
 - └ S5.7 CAN/CANopen/DNet
 - └ S5.9 Bluetooth
- └ S6 SoftPLC
 - └ S6.1 Program Execution
 - └ S6.2 Control and References
- └ S7 User

D Diagnostics

- └ D1 Faults
 - └ D1.1 Actual
 - └ D1.2 History
- └ D2 Alarms
 - └ D2.1 Actual
 - └ D2.2 History
- └ D3 Hour Control
- └ D4 Inverter and Control Access.
 - └ D4.1 Inverter
 - └ D4.1.1 Fan Speed
 - └ D4.1.2 Temperatures
 - └ D4.1.3 DC Link
 - └ D4.1.4 Control Voltages
 - └ D4.1.5 Motor Overl. Fault
 - └ D4.1.6 Thermal Management
 - └ D4.2 Control Accessories
 - └ D4.2.1 Diag. Slot A
 - └ D4.2.2 Diag. Slot B
 - └ D4.2.3 Diag. Slot C
 - └ D4.2.4 Diag. Slot D
 - └ D4.2.5 Diag. Slot E
 - └ D4.2.6 Diag. Slot F
 - └ D4.2.7 Diag. Slot G
- └ D5 Changed Parameters

D Diagnostics (cont.)

- └ D5 Changed Parameters (cont.)
 - └ D5.1 Configuration
 - └ D5.2 Application

C Configuration

- └ C1 Inverter and Power Supply
 - └ C1.1 Power Supply
 - └ C1.2 Inverter Use
 - └ C1.3 Switching Frequency
 - └ C1.4 PWM Modulation
 - └ C1.5 Fans Configuration
 - └ C1.6 Other Inverter Config.
- └ C2 Motor
 - └ C2.1 Motor Data
 - └ C2.2 Motor Model Parameters
- └ C3 Control
 - └ C3.1 Configuration
 - └ C3.2 Scalar (V/F) and VVW+ Control
 - └ C3.2.1 V/F Curve
 - └ C3.2.2 VVW+ Optimization
 - └ C3.2.2.1 VVW+ Induction Motor
 - └ C3.2.2.2 VVW+ PM Motor
 - └ C3.2.3 Current Stabilization
 - └ C3.2.4 Pre-Magnetization
 - └ C3.2.5 I/F Control
 - └ C3.3 Vector Control
 - └ C3.3.1 Configuration
 - └ C3.3.2 Regulators
 - └ C3.3.2.1 Speed Regulator
 - └ C3.3.2.2 Torque Regulator
 - └ C3.3.2.3 Flux Regulator
 - └ C3.3.2.4 Current Regulator
 - └ C3.3.3 Output Voltage Limiter
 - └ C3.3.4 Torque Mode
 - └ C3.3.4.1 Speed Limiter
 - └ C3.3.5 Speed Mode
 - └ C3.3.5.1 Torque Limiter
 - └ C3.3.7 Speed Steady State Estimator
 - └ C3.3.9 Online Parameter Estimation
 - └ C3.4 Current Limiter
 - └ C3.5 DC Link Voltage Limiter
 - └ C3.5.1 DC Link Volt.Limit.Config.
 - └ C3.5.2 Scalar and VVW+ Control

C Configuration (cont.)

- └─ C3 Control (cont.)
 - └─ C3.5 DC Link Voltage Limiter (cont.)
 - └─ C3.5.3 Vector Control
 - └─ C3.6 Dynamic Braking
 - └─ C3.7 DC braking
 - └─ C3.8 Flying Start
 - └─ C3.8.1 Flying Start Setting
 - └─ C3.8.2 Scalar and VVW+ Control
 - └─ C3.8.3 Vector Control
 - └─ C3.9 Ride-Through
 - └─ C3.9.1 Ride-Through Config.
 - └─ C3.9.2 Scalar and VVW+ Control
 - └─ C3.9.3 Vector Control
 - └─ C3.10 Advanced Energy Saving
- └─ C4 Commands and References
 - └─ C4.1 LOC/REM Mode Config.
 - └─ C4.2 Commands
 - └─ C4.2.1 R1 Config. Commands
 - └─ C4.2.2 R2 Config. Commands
 - └─ C4.2.3 DIs Config. for Commands
 - └─ C4.2.4 HMI Config. for Commands
 - └─ C4.3 References
 - └─ C4.3.1 Speed
 - └─ C4.3.1.1 Speed Ref. Range
 - └─ C4.3.1.2 Speed Ref. Source
 - └─ C4.3.1.3 Ref. HMI, AIs and FIs
 - └─ C4.3.1.4 E.P. Ref.-DIs Config.
 - └─ C4.3.1.5 Multispeed Ref.
 - └─ C4.3.1.6 Skip Speed
 - └─ C4.3.2 JOG Speed
 - └─ C4.3.3 Torque
- └─ C5 I/Os
 - └─ C5.1 Slot X
 - └─ C5.1.1 Slot X - Analog Inputs
 - └─ C5.1.2 Slot X - Analog Outputs
 - └─ C5.1.3 Slot X - Digital Inputs
 - └─ C5.1.4 Slot X - Digital Outputs
 - └─ C5.1.5 Slot X-Encoder
 - └─ C5.2 Slot A
 - └─ C5.2.1 Slot A-Analog Inputs
 - └─ C5.2.2 Slot A - Analog Outputs
 - └─ C5.2.4 Slot A - Digital Outputs
 - └─ C5.2.5 Slot A-Encoder

C Configuration (cont.)

- └─ C5 I/Os (cont.)
 - └─ C5.2 Slot A (cont.)
 - └─ C5.2.6 Slot A-Temperatures
 - └─ C5.3 Slot B
 - └─ C5.3.1 Slot B-Analog Inputs
 - └─ C5.3.2 Slot B-Analog Outputs
 - └─ C5.3.4 Slot B-Digital Outputs
 - └─ C5.3.5 Slot B-Encoder
 - └─ C5.3.6 Slot B-Temperatures
 - └─ C5.4 Slot C
 - └─ C5.4.1 Slot C-Analog Inputs
 - └─ C5.4.2 Slot C-Analog Outputs
 - └─ C5.4.4 Slot C-Digital Outputs
 - └─ C5.4.5 Slot C-Encoder
 - └─ C5.4.6 Slot C-Temperatures
 - └─ C5.5 Slot D
 - └─ C5.5.1 Slot D-Analog Inputs
 - └─ C5.5.2 Slot D-Analog Outputs
 - └─ C5.5.4 Slot D-Digital Outputs
 - └─ C5.5.5 Slot D-Encoder
 - └─ C5.5.6 Slot D-Temperatures
 - └─ C5.6 Slot E
 - └─ C5.6.1 Slot E-Analog Inputs
 - └─ C5.6.2 Slot E-Analog Outputs
 - └─ C5.6.4 Slot E-Digital Outputs
 - └─ C5.6.5 Slot E-Encoder
 - └─ C5.6.6 Slot E-Temperatures
 - └─ C5.7 Slot F
 - └─ C5.7.1 Slot F-Analog Inputs
 - └─ C5.7.2 Slot F-Analog Outputs
 - └─ C5.7.4 Slot F-Digital Outputs
 - └─ C5.7.5 Slot F-Encoder
 - └─ C5.7.6 Slot F-Temperatures
 - └─ C5.8 Slot G
 - └─ C5.8.1 Slot G-Analog Inputs
 - └─ C5.8.2 Slot G-Analog Outputs
 - └─ C5.8.4 Slot G-Digital Outputs
 - └─ C5.8.5 Slot G-Encoder
 - └─ C5.8.6 Slot G-Temperatures
 - └─ C5.9 DO Operation Levels
- └─ C6 Ramps
 - └─ C6.1 Speed Control Ramps
 - └─ C6.2 Torque Control Ramps

C Configuration (cont.)

- └─ C7 Protections
 - └─ C7.1 Power Supply Phase Loss
 - └─ C7.2 Ground Fault
 - └─ C7.4 Motor Overload Fault
 - └─ C7.5 Over/Undertemp. Prot.
 - └─ C7.6 Fan Speed Fault
 - └─ C7.7 Motor Overspeed
 - └─ C7.8 Pre-charge
 - └─ C7.9 Auto-Reset
 - └─ C7.10 External Fault/Alarm
 - └─ C7.11 Thermal Management
- └─ C8 Functional Safety
- └─ C9 Communications
 - └─ C9.1 Communication Errors
 - └─ C9.1.1 Master Offline
 - └─ C9.1.2 Master Idle/Prog
 - └─ C9.2 I/O Data
 - └─ C9.2.1 Reading Data
 - └─ C9.2.2 Writing Data
 - └─ C9.3 Serial RS485
 - └─ C9.4 Ethernet
 - └─ C9.5 EtherNet/IP
 - └─ C9.6 Modbus TCP
 - └─ C9.8 CAN/CANopen/DNet
 - └─ C9.10 Bluetooth
 - └─ C9.11 SymbiNet
- └─ C10 SoftPLC
 - └─ C10.1 Configuration
 - └─ C10.2 Engineering Unit
- └─ C11 HMI
 - └─ C11.1 Configuration
 - └─ C11.2 Main Screen
 - └─ C11.3 User
 - └─ C11.3.1 Login
 - └─ C11.3.2 Change password
- └─ C12 Backup

W Wizards
A Application

- └─ A1 User Parameters

10 QUICK REFERENCES



Table 10.1: Characteristics of the parameters for the communication protocol

Parameter	Description	Range of values	Decimal places	Class	Instance	Attribute	CIP data type	Net Id	Size	Qty mapped words
S1 Status/Inverter										
S1.1	Status									
S1.1.1	Inverter	0 = Ready 1 = Run 2 = Undervoltage 3 = Fault 4 = Configuration 5 = STO 6 = Power Off 7 = Disabled 8 = SS1 9 = Self-Tuning		64h	01h	6Ah	USINT	6	enum	1
S1.1.2	HMI	0 = Ready 1 = Run 2 = Sub 3 = Fault 4 = Config 5 = STO 6 = P.Off 7 = Disab. 8 = SS1 9 = SelfTun		64h	0Bh	6Eh	USINT	1010	enum	1
S1.1.3	Pre-Charge	0 = Running 1 = Completed		64h	15h	97h	USINT	2051	enum	1
S1.1.4	Config	0 = No Config 1 = Run/Stop Dlx 2 = Forward R1 3 = Forward R2 4 = Reverse R1 5 = Reverse R2 6 = 3-wire Start/Stop 7 = Direction of Rotation Dlx 8 = JOG Dlx 9 = R1/R2 Dlx 10 = Ramp selection Dlx 11 = Oriented Startup 12 = Backup 13 = Not used 14 = SS1 configuration 15 = Switching Frequency 16 = Undefined model		64h	01h	95h	USINT	49	enum	1



Parameter	Description	Range of values	Decimal places	Class	Instance	Attribute	CIP data type	Net Id	Size	Qty mapped words
		17 = Encoder Vector Control 18 = ENC Acc. not configured 19 = Alx/Fix Speed Ref. 20 = PM Motor Control 21 = General Enable Dlx 22 = Multispeed 23 = Not used 24 = Electronic Potentiometer 25 = FI used as DI 26 = Alx/Fix Torque Ref.								
S1.2	Software Version									
S1.2.2	Details									
S1.3	Inverter Data									
S1.3.2	Inverter Serial No.	0 to 4294967295	0	64h	15h	9Ch	UDINT	2056	32bit	2
S1.3.3	Power Board Serial No.	0 to 4294967295	0	64h	15h	9Eh	UDINT	2058	32bit	2
S1.3.4	Power - Options/Voltages	Bit 0 = 200 V Bit 1 = 208/220/230/240 V Bit 2 = 380 V Bit 3 = 400/415 V Bit 4 = 440/460 V Bit 5 = 480 V Bit 6 = 500/525 V Bit 7 = 550/575/600 V Bit 8 = 660/690 V Bit 9 = DC Link Power Supply Bit 10 = Single-phase Power Supply Bit 11 = Three-phase Power Supply Bit 12 = Not used		64h	15h	A4h	WORD	2064	13bit	1
S1.3.5	Rated Current	0.0 to 6553.0 A	1	64h	0Dh	C3h	UINT	1295	16bit	1
S1.3.6	Effective Rated Current	0.0 to 6553.0 A	1	64h	0Dh	C7h	UINT	1299	16bit	1
S1.3.7	Inverter Model Version	0 to 4294967295	0	64h	64h	96h	UDINT	9950	32bit	2
S1.4	Control Accessory Data									
S1.4.1	Backplane									
S1.4.1.1	Model	0 = Disconnected 1 = CFW900-4SLOTS 2 = CFW900-7SLOTS		64h	47h	64h	USINT	7000	enum	1
S1.4.2	Slot A									
S1.4.2.1	Accessory Identified	0 = Unknown 1 = No Accessory 2 = CFW900-IOAI-01 3 = CFW900-IOD-01 4 = CFW900-REL-01 5 = CFW900-TEMP-01 6 = CFW900-ENC-01 7 = Not used 8 = CFW900-CCAN-W		64h	4Ah	6Eh	USINT	7310	enum	1



Parameter	Description	Range of values	Decimal places	Class	Instance	Attribute	CIP data type	Net Id	Size	Qty mapped words
		9 = Not used								
S1.4.3	Slot B									
S1.4.3.1	Accessory Identified	0 = Unknown 1 = No Accessory 2 = CFW900-IOAI-01 3 = CFW900-IOD-01 4 = CFW900-REL-01 5 = CFW900-TEMP-01 6 = CFW900-ENC-01 7 = Not used 8 = CFW900-CCAN-W 9 = Not used		64h	4Dh	6Eh	USINT	7610	enum	1
S1.4.4	Slot C									
S1.4.4.1	Accessory Identified	0 = Unknown 1 = No Accessory 2 = CFW900-IOAI-01 3 = CFW900-IOD-01 4 = CFW900-REL-01 5 = CFW900-TEMP-01 6 = CFW900-ENC-01 7 = Not used 8 = CFW900-CCAN-W 9 = Not used		64h	50h	6Eh	USINT	7910	enum	1
S1.4.5	Slot D									
S1.4.5.1	Accessory Identified	0 = Unknown 1 = No Accessory 2 = CFW900-IOAI-01 3 = CFW900-IOD-01 4 = CFW900-REL-01 5 = CFW900-TEMP-01 6 = CFW900-ENC-01 7 = Not used 8 = CFW900-CCAN-W 9 = Not used		64h	53h	6Eh	USINT	8210	enum	1
S1.4.6	Slot E									
S1.4.6.1	Accessory Identified	0 = Unknown 1 = No Accessory 2 = CFW900-IOAI-01 3 = CFW900-IOD-01 4 = CFW900-REL-01 5 = CFW900-TEMP-01 6 = CFW900-ENC-01 7 = Not used 8 = CFW900-CCAN-W 9 = Not used		64h	56h	6Eh	USINT	8510	enum	1



Parameter	Description	Range of values	Decimal places	Class	Instance	Attribute	CIP data type	Net Id	Size	Qty mapped words
S1.4.7	Slot F									
S1.4.7.1	Accessory Identified	0 = Unknown 1 = No Accessory 2 = CFW900-IOAI-01 3 = CFW900-IOD-01 4 = CFW900-REL-01 5 = CFW900-TEMP-01 6 = CFW900-ENC-01 7 = Not used 8 = CFW900-CCAN-W 9 = Not used		64h	59h	6Eh	USINT	8810	enum	1
S1.4.8	Slot G									
S1.4.8.1	Accessory Identified	0 = Unknown 1 = No Accessory 2 = CFW900-IOAI-01 3 = CFW900-IOD-01 4 = CFW900-REL-01 5 = CFW900-TEMP-01 6 = CFW900-ENC-01 7 = Not used 8 = CFW900-CCAN-W 9 = Not used		64h	5Ch	6Eh	USINT	9110	enum	1
S1.5	Date/Hour									
S1.5.1	Actual	to	0	64h	0Bh	6Ch	UDINT	1008	NONE	2
S1.6	Control Words									
S1.6.1	Global	Bit 0 = Enable Ramp Bit 1 = General Enable Bit 2 = Run Reverse Bit 3 = Enable JOG Bit 4 = R1/R2 Mode Bit 5 = 2nd Ramp Bit 6 = No Quick Stop Bit 7 = Fault Reset		64h	07h	A6h	WORD	666	8bit	1
S1.6.2	HMI	Bit 0 = Enable Ramp Bit 1 = General Enable Bit 2 = Run Reverse Bit 3 = Enable JOG Bit 4 = LOC/REM Mode Bit 5 = 2nd Ramp Bit 6 = No Quick Stop Bit 7 = Reset Fault		64h	07h	A8h	WORD	668	8bit	1
S1.6.3	DI	Bit 0 = Enable Ramp Bit 1 = General Enable Bit 2 = Run Reverse		64h	07h	AAh	WORD	670	8bit	1



Parameter	Description	Range of values	Decimal places	Class	Instance	Attribute	CIP data type	Net Id	Size	Qty mapped words
		Bit 3 = Enable JOG Bit 4 = R1/R2 Mode Bit 5 = 2nd Ramp Bit 6 = No Quick Stop Bit 7 = Fault Reset								
S2 Status/Measurements										
S2.1	Motor Speed									
S2.1.1	Reference	0 to 60000 rpm	0	64h	01h	65h	UINT	1	16bit	1
S2.1.2	Total Reference	0 to 60000 rpm	0	64h	0Bh	6Fh	UINT	1011	16bit	1
S2.1.3	Actual Value	0 to 60000 rpm	0	64h	01h	66h	UINT	2	16bit	1
S2.1.4	Encoder	0 to 65535 rpm	0	64h	01h	8Ah	UINT	38	16bit	1
S2.1.5	Estimated Value	0 to 60000 rpm	0	64h	01h	8Bh	UINT	39	16bit	1
S2.2	Motor Torque									
S2.2.1	Reference	-400.0 to 400.0 %	1	64h	01h	70h	INT	12	s16bit	1
S2.2.2	Total Reference	-400.0 to 400.0 %	1	64h	1Fh	A8h	REAL	3068	TIME	2
S2.2.3	Estimated Value	-400.0 to 400.0 %	1	64h	01h	6Dh	INT	9	s16bit	1
S2.3	Inverter Output									
S2.3.1	Current	0.0 to 4500.0 A	1	64h	01h	67h	UINT	3	16bit	1
S2.3.2	Voltage	0 to 2000 V	0	64h	01h	6Bh	UINT	7	16bit	1
S2.3.3	Frequency	0.0 to 1020.0 Hz	1	64h	01h	69h	UINT	5	16bit	1
S2.3.4	cos phi	-1.00 to 1.00	2	64h	01h	6Fh	INT	11	s16bit	1
S2.3.5	Power	0.00 to 655.35 kW	2	64h	01h	6Eh	UINT	10	16bit	1
S2.3.6	Energy GWh	0 to 999 GWh	0	64h	1Fh	91h	UINT	3045	16bit	1
S2.3.7	Energy MWh	0 to 999 MWh	0	64h	1Fh	92h	UINT	3046	16bit	1
S2.3.8	Energy kWh	0.0 to 999.9 kWh	1	64h	01h	94h	UINT	48	16bit	1
S2.3.9	Current Switc. Freq.	0.00 to 16.00 kHz	2	64h	1Fh	8Ch	UINT	3040	16bit	1
S2.4	Motor Temperatures									
S2.4.1	Thermal Image	0.00 to 655.35 %	2	64h	04h	A4h	UINT	364	16bit	1
S2.4.3	Sensor Measured Value	-100.0 to 250.0 °C	1	64h	04h	A5h	INT	365	s16bit	1
S2.5	Inverter Temperatures									
S2.5.1	IGBT Temperature									
S2.5.1.1	Phase U/T1 IGBT1	-50.0 to 250.0 °C	1	64h	15h	78h	INT	2020	s16bit	1
S2.5.1.2	Phase V/T2 IGBT1	-50.0 to 250.0 °C	1	64h	15h	79h	INT	2021	s16bit	1
S2.5.1.3	Phase W/T3 IGBT1	-50.0 to 250.0 °C	1	64h	15h	7Ah	INT	2022	s16bit	1
S2.5.3	Internal Air Temperature									
S2.5.3.1	Power	-50.0 to 250.0 °C	1	64h	15h	81h	INT	2029	s16bit	1
S2.5.3.2	Control	-50.0 to 250.0 °C	1	64h	0Ah	BEh	INT	990	s16bit	1
S2.7	DC Link									
S2.7.1	Voltage	0 to 2000 V	0	64h	01h	68h	UINT	4	16bit	1
S2.8	Torque Current Limitation									
S2.8.1	Aix Global Torque	0.0 to 400.0 %	1	64h	1Fh	BEh	UINT	3090	16bit	1
S3 Status I/Os										
S3.1	Slot X Status									
S3.1.1	Analog Inputs									
S3.1.1.1	A11	-100.00 to 100.00 %	2	64h	47h	75h	INT	7017	s16bit	1
S3.1.1.2	A12	-100.00 to 100.00 %	2	64h	47h	76h	INT	7018	s16bit	1
S3.1.2	Analog Outputs									



Parameter	Description	Range of values	Decimal places	Class	Instance	Attribute	CIP data type	Net Id	Size	Qty mapped words
S3.1.2.1	AO1	-100.00 to 100.00 %	2	64h	47h	83h	INT	7031	s16bit	1
S3.1.2.2	AO1 Network	-100.00 to 100.00 %	2	64h	47h	87h	INT	7035	s16bit	1
S3.1.2.3	AO1 SoftPLC	-100.00 to 100.00 %	2	64h	47h	8Bh	INT	7039	s16bit	1
S3.1.2.4	AO2	-100.00 to 100.00 %	2	64h	47h	84h	INT	7032	s16bit	1
S3.1.2.5	AO2 Network	-100.00 to 100.00 %	2	64h	47h	88h	INT	7036	s16bit	1
S3.1.2.6	AO2 SoftPLC	-100.00 to 100.00 %	2	64h	47h	8Ch	INT	7040	s16bit	1
S3.1.3	Digital Inputs									
S3.1.3.1	DI	Bit 0 = DI1 Bit 1 = DI2 Bit 2 = DI3 Bit 3 = DI4 Bit 4 = DI5 Bit 5 = DI6		64h	47h	74h	WORD	7016	6bit	1
S3.1.3.2	FI5	-100.00 to 100.00 %	2	64h	47h	BAh	INT	7086	s16bit	1
S3.1.3.3	FI5 (Hz)	0 to 32000 Hz	0	64h	47h	BCh	UINT	7088	16bit	1
S3.1.3.4	FI6	-100.00 to 100.00 %	2	64h	47h	BBh	INT	7087	s16bit	1
S3.1.3.5	FI6 (Hz)	0 to 32000 Hz	0	64h	47h	BDh	UINT	7089	16bit	1
S3.1.4	Digital Outputs									
S3.1.4.1	DO	Bit 0 = DO1 Bit 1 = DO2		64h	47h	7Fh	WORD	7027	2bit	1
S3.1.4.2	DO Network	Bit 0 = DO1 Bit 1 = DO2		64h	47h	80h	WORD	7028	2bit	1
S3.1.4.3	DO SoftPLC	Bit 0 = DO1 Bit 1 = DO2		64h	47h	81h	WORD	7029	2bit	1
S3.1.4.4	FO1	-100.00 to 100.00 %	2	64h	47h	BEh	INT	7090	s16bit	1
S3.1.4.5	FO1 (Hz)	0 to 32000 Hz	0	64h	47h	C0h	UINT	7092	16bit	1
S3.1.4.6	FO1 Network	-100.00 to 100.00 %	2	64h	47h	C2h	INT	7094	s16bit	1
S3.1.4.7	FO1 SoftPLC	-100.00 to 100.00 %	2	64h	47h	C4h	INT	7096	s16bit	1
S3.1.4.8	FO2	-100.00 to 100.00 %	2	64h	47h	BFh	INT	7091	s16bit	1
S3.1.4.9	FO2 (Hz)	0 to 32000 Hz	0	64h	47h	C1h	UINT	7093	16bit	1
S3.1.4.10	FO2 Network	-100.00 to 100.00 %	2	64h	47h	C3h	INT	7095	s16bit	1
S3.1.4.11	FO2 SoftPLC	-100.00 to 100.00 %	2	64h	47h	C5h	INT	7097	s16bit	1
S3.1.5	Encoder									
S3.1.5.1	Number of Revolutions	0 to 65535	0	64h	47h	6Fh	UINT	7011	16bit	1
S3.1.5.2	Revolution Fraction	0 to 65535	0	64h	47h	70h	UINT	7012	16bit	1
S3.1.5.3	Speed	-60000 to 60000 rpm	0	64h	47h	72h	DINT	7014	s32bit	2
S3.2	Slot A Status									
S3.2.1	Analog Inputs									
S3.2.1.1	AI1	-100.00 to 100.00 %	2	64h	4Ah	75h	INT	7317	s16bit	1
S3.2.1.2	AI2	-100.00 to 100.00 %	2	64h	4Ah	76h	INT	7318	s16bit	1
S3.2.1.3	AI3	-100.00 to 100.00 %	2	64h	4Ah	77h	INT	7319	s16bit	1
S3.2.2	Analog Outputs									
S3.2.2.1	AO1	-100.00 to 100.00 %	2	64h	4Ah	83h	INT	7331	s16bit	1
S3.2.2.2	AO1 Network	-100.00 to 100.00 %	2	64h	4Ah	87h	INT	7335	s16bit	1
S3.2.2.3	AO1 SoftPLC	-100.00 to 100.00 %	2	64h	4Ah	8Bh	INT	7339	s16bit	1



Parameter	Description	Range of values	Decimal places	Class	Instance	Attribute	CIP data type	Net Id	Size	Qty mapped words
S3.2.2.4	AO2	-100.00 to 100.00 %	2	64h	4Ah	84h	INT	7332	s16bit	1
S3.2.2.5	AO2 Network	-100.00 to 100.00 %	2	64h	4Ah	88h	INT	7336	s16bit	1
S3.2.2.6	AO2 SoftPLC	-100.00 to 100.00 %	2	64h	4Ah	8Ch	INT	7340	s16bit	1
S3.2.3	Digital Inputs									
S3.2.3.1	DI	Bit 0 = DI1 Bit 1 = DI2 Bit 2 = DI3 Bit 3 = DI4 Bit 4 = DI5 Bit 5 = DI6 Bit 6 = DI7 Bit 7 = DI8		64h	4Ah	74h	WORD	7316	8bit	1
S3.2.4	Digital Outputs									
S3.2.4.1	DO	Bit 0 = DO1 Bit 1 = DO2 Bit 2 = DO3 Bit 3 = DO4 Bit 4 = DO5 Bit 5 = DO6 Bit 6 = DO7 Bit 7 = DO8		64h	4Ah	7Fh	WORD	7327	8bit	1
S3.2.4.2	DO Network	Bit 0 = DO1 Bit 1 = DO2 Bit 2 = DO3 Bit 3 = DO4 Bit 4 = DO5 Bit 5 = DO6 Bit 6 = DO7 Bit 7 = DO8		64h	4Ah	80h	WORD	7328	8bit	1
S3.2.4.3	DO SoftPLC	Bit 0 = DO1 Bit 1 = DO2 Bit 2 = DO3 Bit 3 = DO4 Bit 4 = DO5 Bit 5 = DO6 Bit 6 = DO7 Bit 7 = DO8		64h	4Ah	81h	WORD	7329	8bit	1
S3.2.5	Encoder									
S3.2.5.1	Number of Revolutions	0 to 65535	0	64h	4Ah	6Fh	UINT	7311	16bit	1
S3.2.5.2	Revolution Fraction	0 to 65535	0	64h	4Ah	70h	UINT	7312	16bit	1
S3.2.5.3	Speed	-60000 to 60000 rpm	0	64h	4Ah	72h	DINT	7314	s32bit	2
S3.2.5.4	Search Zero	0 = Inactive 1 = Completed		64h	4Ah	71h	USINT	7313	enum	1
S3.2.6	Temperatures									



Parameter	Description	Range of values	Decimal places	Class	Instance	Attribute	CIP data type	Net Id	Size	Qty mapped words
S3.2.6.1	Sensor 1	-100.0 to 250.0 °C	1	64h	4Ah	79h	INT	7321	s16bit	1
S3.2.6.2	Sensor 2	-100.0 to 250.0 °C	1	64h	4Ah	7Ah	INT	7322	s16bit	1
S3.2.6.3	Sensor 3	-100.0 to 250.0 °C	1	64h	4Ah	7Bh	INT	7323	s16bit	1
S3.2.6.4	Sensor 4	-100.0 to 250.0 °C	1	64h	4Ah	7Ch	INT	7324	s16bit	1
S3.2.6.5	Sensor 5	-100.0 to 250.0 °C	1	64h	4Ah	7Dh	INT	7325	s16bit	1
S3.2.6.6	Sensor 6	-100.0 to 250.0 °C	1	64h	4Ah	7Eh	INT	7326	s16bit	1
S3.3	Slot B Status									
S3.3.1	Analog Inputs									
S3.3.1.1	AI1	-100.00 to 100.00 %	2	64h	4Dh	75h	INT	7617	s16bit	1
S3.3.1.2	AI2	-100.00 to 100.00 %	2	64h	4Dh	76h	INT	7618	s16bit	1
S3.3.1.3	AI3	-100.00 to 100.00 %	2	64h	4Dh	77h	INT	7619	s16bit	1
S3.3.2	Analog Outputs									
S3.3.2.1	AO1	-100.00 to 100.00 %	2	64h	4Dh	83h	INT	7631	s16bit	1
S3.3.2.2	AO1 Network	-100.00 to 100.00 %	2	64h	4Dh	87h	INT	7635	s16bit	1
S3.3.2.3	AO1 SoftPLC	-100.00 to 100.00 %	2	64h	4Dh	8Bh	INT	7639	s16bit	1
S3.3.2.4	AO2	-100.00 to 100.00 %	2	64h	4Dh	84h	INT	7632	s16bit	1
S3.3.2.5	AO2 Network	-100.00 to 100.00 %	2	64h	4Dh	88h	INT	7636	s16bit	1
S3.3.2.6	AO2 SoftPLC	-100.00 to 100.00 %	2	64h	4Dh	8Ch	INT	7640	s16bit	1
S3.3.3	Digital Inputs									
S3.3.3.1	DI	Bit 0 = DI1 Bit 1 = DI2 Bit 2 = DI3 Bit 3 = DI4 Bit 4 = DI5 Bit 5 = DI6 Bit 6 = DI7 Bit 7 = DI8		64h	4Dh	74h	WORD	7616	8bit	1
S3.3.4	Digital Outputs									
S3.3.4.1	DO	Bit 0 = DO1 Bit 1 = DO2 Bit 2 = DO3 Bit 3 = DO4 Bit 4 = DO5 Bit 5 = DO6 Bit 6 = DO7 Bit 7 = DO8		64h	4Dh	7Fh	WORD	7627	8bit	1
S3.3.4.2	DO Network	Bit 0 = DO1 Bit 1 = DO2 Bit 2 = DO3 Bit 3 = DO4 Bit 4 = DO5 Bit 5 = DO6 Bit 6 = DO7 Bit 7 = DO8		64h	4Dh	80h	WORD	7628	8bit	1
S3.3.4.3	DO SoftPLC	Bit 0 = DO1		64h	4Dh	81h	WORD	7629	8bit	1



Parameter	Description	Range of values	Decimal places	Class	Instance	Attribute	CIP data type	Net Id	Size	Qty mapped words
		Bit 1 = DO2 Bit 2 = DO3 Bit 3 = DO4 Bit 4 = DO5 Bit 5 = DO6 Bit 6 = DO7 Bit 7 = DO8								
S3.3.5	Encoder									
S3.3.5.1	Number of Revolutions	0 to 65535	0	64h	4Dh	6Fh	UINT	7611	16bit	1
S3.3.5.2	Revolution Fraction	0 to 65535	0	64h	4Dh	70h	UINT	7612	16bit	1
S3.3.5.3	Speed	-60000 to 60000 rpm	0	64h	4Dh	72h	DINT	7614	s32bit	2
S3.3.5.4	Search Zero	0 = Inactive 1 = Completed		64h	4Dh	71h	USINT	7613	enum	1
S3.3.6	Temperatures									
S3.3.6.1	Sensor 1	-100.0 to 250.0 °C	1	64h	4Dh	79h	INT	7621	s16bit	1
S3.3.6.2	Sensor 2	-100.0 to 250.0 °C	1	64h	4Dh	7Ah	INT	7622	s16bit	1
S3.3.6.3	Sensor 3	-100.0 to 250.0 °C	1	64h	4Dh	7Bh	INT	7623	s16bit	1
S3.3.6.4	Sensor 4	-100.0 to 250.0 °C	1	64h	4Dh	7Ch	INT	7624	s16bit	1
S3.3.6.5	Sensor 5	-100.0 to 250.0 °C	1	64h	4Dh	7Dh	INT	7625	s16bit	1
S3.3.6.6	Sensor 6	-100.0 to 250.0 °C	1	64h	4Dh	7Eh	INT	7626	s16bit	1
S3.4	Slot C Status									
S3.4.1	Analog Inputs									
S3.4.1.1	AI1	-100.00 to 100.00 %	2	64h	50h	75h	INT	7917	s16bit	1
S3.4.1.2	AI2	-100.00 to 100.00 %	2	64h	50h	76h	INT	7918	s16bit	1
S3.4.1.3	AI3	-100.00 to 100.00 %	2	64h	50h	77h	INT	7919	s16bit	1
S3.4.2	Analog Outputs									
S3.4.2.1	AO1	-100.00 to 100.00 %	2	64h	50h	83h	INT	7931	s16bit	1
S3.4.2.2	AO1 Network	-100.00 to 100.00 %	2	64h	50h	87h	INT	7935	s16bit	1
S3.4.2.3	AO1 SoftPLC	-100.00 to 100.00 %	2	64h	50h	8Bh	INT	7939	s16bit	1
S3.4.2.4	AO2	-100.00 to 100.00 %	2	64h	50h	84h	INT	7932	s16bit	1
S3.4.2.5	AO2 Network	-100.00 to 100.00 %	2	64h	50h	88h	INT	7936	s16bit	1
S3.4.2.6	AO2 SoftPLC	-100.00 to 100.00 %	2	64h	50h	8Ch	INT	7940	s16bit	1
S3.4.3	Digital Inputs									
S3.4.3.1	DI	Bit 0 = DI1 Bit 1 = DI2 Bit 2 = DI3 Bit 3 = DI4 Bit 4 = DI5 Bit 5 = DI6 Bit 6 = DI7 Bit 7 = DI8		64h	50h	74h	WORD	7916	8bit	1
S3.4.4	Digital Outputs									
S3.4.4.1	DO	Bit 0 = DO1 Bit 1 = DO2 Bit 2 = DO3 Bit 3 = DO4		64h	50h	7Fh	WORD	7927	8bit	1



Parameter	Description	Range of values	Decimal places	Class	Instance	Attribute	CIP data type	Net Id	Size	Qty mapped words
S3.4.4.2	DO Network	Bit 4 = DO5 Bit 5 = DO6 Bit 6 = DO7 Bit 7 = DO8								
		Bit 0 = DO1 Bit 1 = DO2 Bit 2 = DO3 Bit 3 = DO4 Bit 4 = DO5 Bit 5 = DO6 Bit 6 = DO7 Bit 7 = DO8		64h	50h	80h	WORD	7928	8bit	1
S3.4.4.3	DO SoftPLC	Bit 0 = DO1 Bit 1 = DO2 Bit 2 = DO3 Bit 3 = DO4 Bit 4 = DO5 Bit 5 = DO6 Bit 6 = DO7 Bit 7 = DO8		64h	50h	81h	WORD	7929	8bit	1
S3.4.5	Encoder									
S3.4.5.1	Number of Revolutions	0 to 65535	0	64h	50h	6Fh	UINT	7911	16bit	1
S3.4.5.2	Revolution Fraction	0 to 65535	0	64h	50h	70h	UINT	7912	16bit	1
S3.4.5.3	Speed	-60000 to 60000 rpm	0	64h	50h	72h	DINT	7914	s32bit	2
S3.4.5.4	Search Zero	0 = Inactive 1 = Completed		64h	50h	71h	USINT	7913	enum	1
S3.4.6	Temperatures									
S3.4.6.1	Sensor 1	-100.0 to 250.0 °C	1	64h	50h	79h	INT	7921	s16bit	1
S3.4.6.2	Sensor 2	-100.0 to 250.0 °C	1	64h	50h	7Ah	INT	7922	s16bit	1
S3.4.6.3	Sensor 3	-100.0 to 250.0 °C	1	64h	50h	7Bh	INT	7923	s16bit	1
S3.4.6.4	Sensor 4	-100.0 to 250.0 °C	1	64h	50h	7Ch	INT	7924	s16bit	1
S3.4.6.5	Sensor 5	-100.0 to 250.0 °C	1	64h	50h	7Dh	INT	7925	s16bit	1
S3.4.6.6	Sensor 6	-100.0 to 250.0 °C	1	64h	50h	7Eh	INT	7926	s16bit	1
S3.5	Slot D Status									
S3.5.1	Analog Inputs									
S3.5.1.1	AI1	-100.00 to 100.00 %	2	64h	53h	75h	INT	8217	s16bit	1
S3.5.1.2	AI2	-100.00 to 100.00 %	2	64h	53h	76h	INT	8218	s16bit	1
S3.5.1.3	AI3	-100.00 to 100.00 %	2	64h	53h	77h	INT	8219	s16bit	1
S3.5.2	Analog Outputs									
S3.5.2.1	AO1	-100.00 to 100.00 %	2	64h	53h	83h	INT	8231	s16bit	1
S3.5.2.2	AO1 Network	-100.00 to 100.00 %	2	64h	53h	87h	INT	8235	s16bit	1
S3.5.2.3	AO1 SoftPLC	-100.00 to 100.00 %	2	64h	53h	8Bh	INT	8239	s16bit	1
S3.5.2.4	AO2	-100.00 to 100.00 %	2	64h	53h	84h	INT	8232	s16bit	1
S3.5.2.5	AO2 Network	-100.00 to 100.00 %	2	64h	53h	88h	INT	8236	s16bit	1
S3.5.2.6	AO2 SoftPLC	-100.00 to 100.00 %	2	64h	53h	8Ch	INT	8240	s16bit	1
S3.5.3	Digital Inputs									



Parameter	Description	Range of values	Decimal places	Class	Instance	Attribute	CIP data type	Net Id	Size	Qty mapped words
S3.5.3.1	DI	Bit 0 = DI1 Bit 1 = DI2 Bit 2 = DI3 Bit 3 = DI4 Bit 4 = DI5 Bit 5 = DI6 Bit 6 = DI7 Bit 7 = DI8		64h	53h	74h	WORD	8216	8bit	1
S3.5.4	Digital Outputs									
S3.5.4.1	DO	Bit 0 = DO1 Bit 1 = DO2 Bit 2 = DO3 Bit 3 = DO4 Bit 4 = DO5 Bit 5 = DO6 Bit 6 = DO7 Bit 7 = DO8		64h	53h	7Fh	WORD	8227	8bit	1
S3.5.4.2	DO Network	Bit 0 = DO1 Bit 1 = DO2 Bit 2 = DO3 Bit 3 = DO4 Bit 4 = DO5 Bit 5 = DO6 Bit 6 = DO7 Bit 7 = DO8		64h	53h	80h	WORD	8228	8bit	1
S3.5.4.3	DO SoftPLC	Bit 0 = DO1 Bit 1 = DO2 Bit 2 = DO3 Bit 3 = DO4 Bit 4 = DO5 Bit 5 = DO6 Bit 6 = DO7 Bit 7 = DO8		64h	53h	81h	WORD	8229	8bit	1
S3.5.5	Encoder									
S3.5.5.1	Number of Revolutions	0 to 65535	0	64h	53h	6Fh	UINT	8211	16bit	1
S3.5.5.2	Revolution Fraction	0 to 65535	0	64h	53h	70h	UINT	8212	16bit	1
S3.5.5.3	Speed	-60000 to 60000 rpm	0	64h	53h	72h	DINT	8214	s32bit	2
S3.5.5.4	Search Zero	0 = Inactive 1 = Completed		64h	53h	71h	USINT	8213	enum	1
S3.5.6	Temperatures									
S3.5.6.1	Sensor 1	-100.0 to 250.0 °C	1	64h	53h	79h	INT	8221	s16bit	1
S3.5.6.2	Sensor 2	-100.0 to 250.0 °C	1	64h	53h	7Ah	INT	8222	s16bit	1
S3.5.6.3	Sensor 3	-100.0 to 250.0 °C	1	64h	53h	7Bh	INT	8223	s16bit	1
S3.5.6.4	Sensor 4	-100.0 to 250.0 °C	1	64h	53h	7Ch	INT	8224	s16bit	1



Parameter	Description	Range of values	Decimal places	Class	Instance	Attribute	CIP data type	Net Id	Size	Qty mapped words
S3.5.6.5	Sensor 5	-100.0 to 250.0 °C	1	64h	53h	7Dh	INT	8225	s16bit	1
S3.5.6.6	Sensor 6	-100.0 to 250.0 °C	1	64h	53h	7Eh	INT	8226	s16bit	1
S3.6	Slot E Status									
S3.6.1	Analog Inputs									
S3.6.1.1	AI1	-100.00 to 100.00 %	2	64h	56h	75h	INT	8517	s16bit	1
S3.6.1.2	AI2	-100.00 to 100.00 %	2	64h	56h	76h	INT	8518	s16bit	1
S3.6.1.3	AI3	-100.00 to 100.00 %	2	64h	56h	77h	INT	8519	s16bit	1
S3.6.2	Analog Outputs									
S3.6.2.1	AO1	-100.00 to 100.00 %	2	64h	56h	83h	INT	8531	s16bit	1
S3.6.2.2	AO1 Network	-100.00 to 100.00 %	2	64h	56h	87h	INT	8535	s16bit	1
S3.6.2.3	AO1 SoftPLC	-100.00 to 100.00 %	2	64h	56h	8Bh	INT	8539	s16bit	1
S3.6.2.4	AO2	-100.00 to 100.00 %	2	64h	56h	84h	INT	8532	s16bit	1
S3.6.2.5	AO2 Network	-100.00 to 100.00 %	2	64h	56h	88h	INT	8536	s16bit	1
S3.6.2.6	AO2 SoftPLC	-100.00 to 100.00 %	2	64h	56h	8Ch	INT	8540	s16bit	1
S3.6.3	Digital Inputs									
S3.6.3.1	DI	Bit 0 = DI1 Bit 1 = DI2 Bit 2 = DI3 Bit 3 = DI4 Bit 4 = DI5 Bit 5 = DI6 Bit 6 = DI7 Bit 7 = DI8		64h	56h	74h	WORD	8516	8bit	1
S3.6.4	Digital Outputs									
S3.6.4.1	DO	Bit 0 = DO1 Bit 1 = DO2 Bit 2 = DO3 Bit 3 = DO4 Bit 4 = DO5 Bit 5 = DO6 Bit 6 = DO7 Bit 7 = DO8		64h	56h	7Fh	WORD	8527	8bit	1
S3.6.4.2	DO Network	Bit 0 = DO1 Bit 1 = DO2 Bit 2 = DO3 Bit 3 = DO4 Bit 4 = DO5 Bit 5 = DO6 Bit 6 = DO7 Bit 7 = DO8		64h	56h	80h	WORD	8528	8bit	1
S3.6.4.3	DO SoftPLC	Bit 0 = DO1 Bit 1 = DO2 Bit 2 = DO3 Bit 3 = DO4 Bit 4 = DO5		64h	56h	81h	WORD	8529	8bit	1



Parameter	Description	Range of values	Decimal places	Class	Instance	Attribute	CIP data type	Net Id	Size	Qty mapped words
		Bit 5 = DO6 Bit 6 = DO7 Bit 7 = DO8								
S3.6.5	Encoder									
S3.6.5.1	Number of Revolutions	0 to 65535	0	64h	56h	6Fh	UINT	8511	16bit	1
S3.6.5.2	Revolution Fraction	0 to 65535	0	64h	56h	70h	UINT	8512	16bit	1
S3.6.5.3	Speed	-60000 to 60000 rpm	0	64h	56h	72h	DINT	8514	s32bit	2
S3.6.5.4	Search Zero	0 = Inactive 1 = Completed		64h	56h	71h	USINT	8513	enum	1
S3.6.6	Temperatures									
S3.6.6.1	Sensor 1	-100.0 to 250.0 °C	1	64h	56h	79h	INT	8521	s16bit	1
S3.6.6.2	Sensor 2	-100.0 to 250.0 °C	1	64h	56h	7Ah	INT	8522	s16bit	1
S3.6.6.3	Sensor 3	-100.0 to 250.0 °C	1	64h	56h	7Bh	INT	8523	s16bit	1
S3.6.6.4	Sensor 4	-100.0 to 250.0 °C	1	64h	56h	7Ch	INT	8524	s16bit	1
S3.6.6.5	Sensor 5	-100.0 to 250.0 °C	1	64h	56h	7Dh	INT	8525	s16bit	1
S3.6.6.6	Sensor 6	-100.0 to 250.0 °C	1	64h	56h	7Eh	INT	8526	s16bit	1
S3.7	Slot F Status									
S3.7.1	Analog Inputs									
S3.7.1.1	AI1	-100.00 to 100.00 %	2	64h	59h	75h	INT	8817	s16bit	1
S3.7.1.2	AI2	-100.00 to 100.00 %	2	64h	59h	76h	INT	8818	s16bit	1
S3.7.1.3	AI3	-100.00 to 100.00 %	2	64h	59h	77h	INT	8819	s16bit	1
S3.7.2	Analog Outputs									
S3.7.2.1	AO1	-100.00 to 100.00 %	2	64h	59h	83h	INT	8831	s16bit	1
S3.7.2.2	AO1 Network	-100.00 to 100.00 %	2	64h	59h	87h	INT	8835	s16bit	1
S3.7.2.3	AO1 SoftPLC	-100.00 to 100.00 %	2	64h	59h	8Bh	INT	8839	s16bit	1
S3.7.2.4	AO2	-100.00 to 100.00 %	2	64h	59h	84h	INT	8832	s16bit	1
S3.7.2.5	AO2 Network	-100.00 to 100.00 %	2	64h	59h	88h	INT	8836	s16bit	1
S3.7.2.6	AO2 SoftPLC	-100.00 to 100.00 %	2	64h	59h	8Ch	INT	8840	s16bit	1
S3.7.3	Digital Inputs									
S3.7.3.1	DI	Bit 0 = DI1 Bit 1 = DI2 Bit 2 = DI3 Bit 3 = DI4 Bit 4 = DI5 Bit 5 = DI6 Bit 6 = DI7 Bit 7 = DI8		64h	59h	74h	WORD	8816	8bit	1
S3.7.4	Digital Outputs									
S3.7.4.1	DO	Bit 0 = DO1 Bit 1 = DO2 Bit 2 = DO3 Bit 3 = DO4 Bit 4 = DO5 Bit 5 = DO6 Bit 6 = DO7 Bit 7 = DO8		64h	59h	7Fh	WORD	8827	8bit	1



Parameter	Description	Range of values	Decimal places	Class	Instance	Attribute	CIP data type	Net Id	Size	Qty mapped words
S3.7.4.2	DO Network	Bit 0 = DO1 Bit 1 = DO2 Bit 2 = DO3 Bit 3 = DO4 Bit 4 = DO5 Bit 5 = DO6 Bit 6 = DO7 Bit 7 = DO8		64h	59h	80h	WORD	8828	8bit	1
S3.7.4.3	DO SoftPLC	Bit 0 = DO1 Bit 1 = DO2 Bit 2 = DO3 Bit 3 = DO4 Bit 4 = DO5 Bit 5 = DO6 Bit 6 = DO7 Bit 7 = DO8		64h	59h	81h	WORD	8829	8bit	1
S3.7.5	Encoder									
S3.7.5.1	Number of Revolutions	0 to 65535	0	64h	59h	6Fh	UINT	8811	16bit	1
S3.7.5.2	Revolution Fraction	0 to 65535	0	64h	59h	70h	UINT	8812	16bit	1
S3.7.5.3	Speed	-60000 to 60000 rpm	0	64h	59h	72h	DINT	8814	s32bit	2
S3.7.5.4	Search Zero	0 = Inactive 1 = Completed		64h	59h	71h	USINT	8813	enum	1
S3.7.6	Temperatures									
S3.7.6.1	Sensor 1	-100.0 to 250.0 °C	1	64h	59h	79h	INT	8821	s16bit	1
S3.7.6.2	Sensor 2	-100.0 to 250.0 °C	1	64h	59h	7Ah	INT	8822	s16bit	1
S3.7.6.3	Sensor 3	-100.0 to 250.0 °C	1	64h	59h	7Bh	INT	8823	s16bit	1
S3.7.6.4	Sensor 4	-100.0 to 250.0 °C	1	64h	59h	7Ch	INT	8824	s16bit	1
S3.7.6.5	Sensor 5	-100.0 to 250.0 °C	1	64h	59h	7Dh	INT	8825	s16bit	1
S3.7.6.6	Sensor 6	-100.0 to 250.0 °C	1	64h	59h	7Eh	INT	8826	s16bit	1
S3.8	Slot G Status									
S3.8.1	Analog Inputs									
S3.8.1.1	AI1	-100.00 to 100.00 %	2	64h	5Ch	75h	INT	9117	s16bit	1
S3.8.1.2	AI2	-100.00 to 100.00 %	2	64h	5Ch	76h	INT	9118	s16bit	1
S3.8.1.3	AI3	-100.00 to 100.00 %	2	64h	5Ch	77h	INT	9119	s16bit	1
S3.8.2	Analog Outputs									
S3.8.2.1	AO1	-100.00 to 100.00 %	2	64h	5Ch	83h	INT	9131	s16bit	1
S3.8.2.2	AO1 Network	-100.00 to 100.00 %	2	64h	5Ch	87h	INT	9135	s16bit	1
S3.8.2.3	AO1 SoftPLC	-100.00 to 100.00 %	2	64h	5Ch	8Bh	INT	9139	s16bit	1
S3.8.2.4	AO2	-100.00 to 100.00 %	2	64h	5Ch	84h	INT	9132	s16bit	1
S3.8.2.5	AO2 Network	-100.00 to 100.00 %	2	64h	5Ch	88h	INT	9136	s16bit	1
S3.8.2.6	AO2 SoftPLC	-100.00 to 100.00 %	2	64h	5Ch	8Ch	INT	9140	s16bit	1
S3.8.3	Digital Inputs									
S3.8.3.1	DI	Bit 0 = DI1 Bit 1 = DI2 Bit 2 = DI3		64h	5Ch	74h	WORD	9116	8bit	1



Parameter	Description	Range of values	Decimal places	Class	Instance	Attribute	CIP data type	Net Id	Size	Qty mapped words
		Bit 3 = DI4 Bit 4 = DI5 Bit 5 = DI6 Bit 6 = DI7 Bit 7 = DI8								
S3.8.4	Digital Outputs									
S3.8.4.1	DO	Bit 0 = DO1 Bit 1 = DO2 Bit 2 = DO3 Bit 3 = DO4 Bit 4 = DO5 Bit 5 = DO6 Bit 6 = DO7 Bit 7 = DO8		64h	5Ch	7Fh	WORD	9127	8bit	1
S3.8.4.2	DO Network	Bit 0 = DO1 Bit 1 = DO2 Bit 2 = DO3 Bit 3 = DO4 Bit 4 = DO5 Bit 5 = DO6 Bit 6 = DO7 Bit 7 = DO8		64h	5Ch	80h	WORD	9128	8bit	1
S3.8.4.3	DO SoftPLC	Bit 0 = DO1 Bit 1 = DO2 Bit 2 = DO3 Bit 3 = DO4 Bit 4 = DO5 Bit 5 = DO6 Bit 6 = DO7 Bit 7 = DO8		64h	5Ch	81h	WORD	9129	8bit	1
S3.8.5	Encoder									
S3.8.5.1	Number of Revolutions	0 to 65535	0	64h	5Ch	6Fh	UINT	9111	16bit	1
S3.8.5.2	Revolution Fraction	0 to 65535	0	64h	5Ch	70h	UINT	9112	16bit	1
S3.8.5.3	Speed	-60000 to 60000 rpm	0	64h	5Ch	72h	DINT	9114	s32bit	2
S3.8.5.4	Search Zero	0 = Inactive 1 = Completed		64h	5Ch	71h	USINT	9113	enum	1
S3.8.6	Temperatures									
S3.8.6.1	Sensor 1	-100.0 to 250.0 °C	1	64h	5Ch	79h	INT	9121	s16bit	1
S3.8.6.2	Sensor 2	-100.0 to 250.0 °C	1	64h	5Ch	7Ah	INT	9122	s16bit	1
S3.8.6.3	Sensor 3	-100.0 to 250.0 °C	1	64h	5Ch	7Bh	INT	9123	s16bit	1
S3.8.6.4	Sensor 4	-100.0 to 250.0 °C	1	64h	5Ch	7Ch	INT	9124	s16bit	1
S3.8.6.5	Sensor 5	-100.0 to 250.0 °C	1	64h	5Ch	7Dh	INT	9125	s16bit	1
S3.8.6.6	Sensor 6	-100.0 to 250.0 °C	1	64h	5Ch	7Eh	INT	9126	s16bit	1
S4 Status\Functional Safety										
S4.1	Status			64h	01h	BEh	USINT	90	enum	1



Parameter	Description	Range of values	Decimal places	Class	Instance	Attribute	CIP data type	Net Id	Size	Qty mapped words
S4.2	SS1-t Delay Time	0 = Not used 1 = STO 2 = Operational 3 = Programming 4 = SS1-t 5 = Fault 0 to 999 s	0	64h	01h	C0h	UINT	92	16bit	1
S5 Status\Communications										
S5.1	Status and Commands									
S5.1.1	Status Word 1	Bit 0 = STO Bit 1 = Run Command Bit 2 = Local Bit 3 = Not used Bit 4 = No Quick Stop Bit 5 = 2nd Ramp Bit 6 = Config. Mode Bit 7 = Alarm Bit 8 = Running Bit 9 = Enabled Bit 10 = Reverse Bit 11 = JOG Bit 12 = Remote 2 Bit 13 = Undervoltage Bit 14 = Not used Bit 15 = Fault		64h	07h	B4h	WORD	680	16bit	1
S5.1.2	Speed	-200.00 to 200.00 %	2	64h	07h	B5h	INT	681	s16bit	1
S5.1.3	Status Word 2	Bit 0 = Self-tuning Bit 1 = Not used Bit 2 = Pre-Charge OK Bit 3 = SF Reduction Bit 4 = Not used Bit 5 = Decel. Ramp Bit 6 = Accel. Ramp Bit 7 = Freeze Ramp Bit 8 = Setpoint OK Bit 9 = DC Voltage Limitation Bit 10 = Current Limitation Bit 11 = Torque Limitation Bit 12 = Ride-Through Bit 13 = Flying Start Bit 14 = DC Braking Bit 15 = PWM pulses		64h	07h	BEh	WORD	690	16bit	1
S5.1.4	Status Word 3	Bit 0 = SD Card Bit 1 = Not used		64h	07h	BFh	WORD	691	2bit	1
S5.2	Serial RS485									
S5.2.1	Interface Status	0 = Inactive		64h	08h	87h	USINT	735	enum	1



Parameter	Description	Range of values	Decimal places	Class	Instance	Attribute	CIP data type	Net Id	Size	Qty mapped words
S5.2.2	Control Word	1 = Active 2 = Timeout Error Bit 0 = Enable Ramp Bit 1 = General Enable Bit 2 = Run Reverse Bit 3 = Enable JOG Bit 4 = R1/R2 Mode Bit 5 = 2nd Ramp Bit 6 = No Quick Stop Bit 7 = Fault Reset		64h	07h	B6h	WORD	682	8bit	1
S5.2.3	Speed Reference	-200.00 to 200.00 %	2	64h	07h	B7h	INT	683	s16bit	1
S5.2.5	Received Telegrams	0 to 65535	0	64h	08h	88h	UINT	736	16bit	1
S5.2.6	Transmitted Telegrams	0 to 65535	0	64h	08h	89h	UINT	737	16bit	1
S5.2.7	Telegramms with Error	0 to 65535	0	64h	08h	8Ah	UINT	738	16bit	1
S5.2.8	Reception Errors	0 to 65535	0	64h	08h	8Bh	UINT	739	16bit	1
S5.3	Ethernet									
S5.3.1	Interface Status	Bit 0 = Link 1 Bit 1 = Link 2		64h	09h	BEh	WORD	890	2bit	1
S5.3.2	Control Word	Bit 0 = Enable Ramp Bit 1 = General Enable Bit 2 = Run Reverse Bit 3 = Enable JOG Bit 4 = R1/R2 Mode Bit 5 = 2nd Ramp Bit 6 = No Quick Stop Bit 7 = Fault Reset		64h	07h	A4h	WORD	664	8bit	1
S5.3.3	Speed Reference	-200.00 to 200.00 %	2	64h	07h	A5h	INT	665	s16bit	1
S5.3.5	Actual IP Address	0.0.0.0 to 255.255.255.255		64h	09h	92h	UDINT	846	STRING	2
S5.3.6	MQTT Status	0 = Inactive 1 = No Connection 2 = Connected		64h	09h	8Dh	USINT	841	enum	1
S5.3.7	Last Public. MQTT	to	0	64h	09h	8Eh	UDINT	842	NONE	2
S5.3.8	SNTP - Status	0 = Inactive 1 = No Connection 2 = Connected		64h	08h	B2h	USINT	778	enum	1
S5.3.9	SNTP - Last update	to	0	64h	08h	B4h	UDINT	780	NONE	2
S5.3.10	SymbiNet: Groups Status	Bit 0 = Group 1 Status Bit 1 = Group 2 Status Bit 2 = Group 3 Status Bit 3 = Group 4 Status Bit 4 = Group 5 Status Bit 5 = Group 6 Status Bit 6 = Group 7 Status Bit 7 = Group 8 Status		64h	0Bh	A7h	WORD	1067	8bit	1



Parameter	Description	Range of values	Decimal places	Class	Instance	Attribute	CIP data type	Net Id	Size	Qty mapped words
S5.4	EtherNet/IP									
S5.4.1	EIP Master Status	0 = Run 1 = Idle		64h	09h	A9h	USINT	869	enum	1
S5.4.2	Communication Status	0 = Inactive 1 = No Connection 2 = Connected 3 = I/O Connection Timeout 4 = Duplicate IP		64h	09h	AAh	USINT	870	enum	1
S5.4.3	DLR Topology	0 = Linear 1 = Ring		64h	09h	B0h	USINT	876	enum	1
S5.4.4	DLR Status	0 = Idle State 1 = Normal State 2 = Fault State		64h	09h	B1h	USINT	877	enum	1
S5.5	Modbus TCP									
S5.5.1	Communication Status	0 = Inactive 1 = No Connection 2 = Connected 3 = Timeout Error		64h	09h	A0h	USINT	860	enum	1
S5.5.2	Received Telegrams	0 to 65535	0	64h	09h	A1h	UINT	861	16bit	1
S5.5.3	Transmitted Telegrams	0 to 65535	0	64h	09h	A2h	UINT	862	16bit	1
S5.5.4	Active Connections	0 to 4	0	64h	09h	A3h	UINT	863	16bit	1
S5.7	CAN/CANopen/DNet									
S5.7.1	CAN Controller Status	0 = Disabled 1 = Auto-Baud 2 = CAN Active 3 = Warning 4 = Error Passive 5 = Bus Off 6 = No Bus Power		64h	08h	69h	USINT	705	enum	1
S5.7.2	Control Word	Bit 0 = Enable Ramp Bit 1 = General Enable Bit 2 = Run Reverse Bit 3 = Enable JOG Bit 4 = R1/R2 Mode Bit 5 = 2nd Ramp Bit 6 = No Quick Stop Bit 7 = Fault Reset		64h	07h	B8h	WORD	684	8bit	1
S5.7.3	Speed Reference	-200.00 to 200.00 %	2	64h	07h	B9h	INT	685	s16bit	1
S5.7.5	Received Telegrams	0 to 65535	0	64h	08h	6Ah	UINT	706	16bit	1
S5.7.6	Transmitted Telegrams	0 to 65535	0	64h	08h	6Bh	UINT	707	16bit	1
S5.7.7	Bus Off Counter	0 to 65535	0	64h	08h	6Ch	UINT	708	16bit	1
S5.7.8	Lost Messages	0 to 65535	0	64h	08h	6Dh	UINT	709	16bit	1



Parameter	Description	Range of values	Decimal places	Class	Instance	Attribute	CIP data type	Net Id	Size	Qty mapped words
S5.7.9	CANopen Comm. Status	0 = Inactive 1 = Reserved 2 = Comm. Enabled 3 = Enab. Error Ctrl. 4 = Guarding Error 5 = Heartbeat Error		64h	08h	79h	USINT	721	enum	1
S5.7.10	CANopen Node Status	0 = Inactive 1 = Initialization 2 = Stopped 3 = Operational 4 = Pre-Operational		64h	08h	7Ah	USINT	722	enum	1
S5.7.11	DNet Network Status	0 = Offline 1 = Online Not Conn. 2 = Online Connected 3 = Conn. Timed Out 4 = Link Failure 5 = Auto-Baud		64h	08h	74h	USINT	716	enum	1
S5.7.12	DNet Master Status	0 = Run 1 = Idle		64h	08h	75h	USINT	717	enum	1
S5.9	Bluetooth									
S6 Status\SoftPLC										
S6.1	Program Execution									
S6.1.1	Status	0 = No Program 1 = Saving Program 2 = Invalid Program 3 = Program Stopped 4 = Program Running		64h	33h	64h	USINT	5000	enum	1
S6.1.2	Time	0 to 65535 ms	0	64h	33h	65h	UINT	5001	16bit	1
S6.2	Control and References									
S6.2.1	Control Word	Bit 0 = Enable Ramp Bit 1 = General Enable Bit 2 = Run Reverse Bit 3 = Enable JOG Bit 4 = R1/R2 Mode Bit 5 = 2nd Ramp Bit 6 = No Quick Stop Bit 7 = Fault Reset		64h	34h	6Eh	WORD	5110	8bit	1
S6.2.3	Speed Reference	-200.00 to 200.00 %	2	64h	34h	70h	INT	5112	s16bit	1
S7 Status\User										
S7.1	Login Active	0 = Administrator 1 = Operator 2 ... 5 = Not used		64h	02h	C7h	USINT	199	enum	1



Parameter	Description	Range of values	Decimal places	Class	Instance	Attribute	CIP data type	Net Id	Size	Qty mapped words
D1 Diagnostics\Faults										
D1.1	Actual									
D1.1.1	Fault 1	0 to 1999	0	64h	01h	A0h	UINT	60	16bit	1
D1.1.2	Fault 2	0 to 1999	0	64h	01h	A1h	UINT	61	16bit	1
D1.1.3	Fault 3	0 to 1999	0	64h	01h	A2h	UINT	62	16bit	1
D1.1.4	Fault 4	0 to 1999	0	64h	01h	A3h	UINT	63	16bit	1
D1.1.5	Fault 5	0 to 1999	0	64h	01h	A4h	UINT	64	16bit	1
D1.2	History									
D2 Diagnostics\Alarms										
D2.1	Actual									
D2.1.1	Alarm 1	0 to 1999	0	64h	01h	96h	UINT	50	16bit	1
D2.1.2	Alarm 2	0 to 1999	0	64h	01h	97h	UINT	51	16bit	1
D2.1.3	Alarm 3	0 to 1999	0	64h	01h	98h	UINT	52	16bit	1
D2.1.4	Alarm 4	0 to 1999	0	64h	01h	99h	UINT	53	16bit	1
D2.1.5	Alarm 5	0 to 1999	0	64h	01h	9Ah	UINT	54	16bit	1
D2.2	History									
D3 Diagnostics\Hour Control										
D4 Diagnostics\Inverter and Control Access.										
D4.1	Inverter									
D4.1.1	Fan Speed									
D4.1.1.1	Power Fan 1 Speed	0 to 30000 rpm	0	64h	15h	72h	UINT	2014	16bit	1
D4.1.1.2	Power Fan 2 Speed	0 to 30000 rpm	0	64h	15h	73h	UINT	2015	16bit	1
D4.1.1.3	Power Fan 3 Speed	0 to 30000 rpm	0	64h	15h	74h	UINT	2016	16bit	1
D4.1.1.4	Power Fan 4 Speed	0 to 30000 rpm	0	64h	15h	75h	UINT	2017	16bit	1
D4.1.1.5	Int. Fan 1 Speed	0 to 30000 rpm	0	64h	15h	76h	UINT	2018	16bit	1
D4.1.1.6	Int. Fan 2 Speed	0 to 30000 rpm	0	64h	15h	77h	UINT	2019	16bit	1
D4.1.2	Temperatures									
D4.1.2.2	Control Temperature 2	-50.0 to 250.0 °C	1	64h	0Ah	BFh	INT	991	s16bit	1
D4.1.2.3	Control Temperature 3	-50.0 to 250.0 °C	1	64h	0Ah	C0h	INT	992	s16bit	1
D4.1.2.4	Power Temp. 2	-50.0 to 250.0 °C	1	64h	15h	82h	INT	2030	s16bit	1
D4.1.3	DC Link									
D4.1.3.1	100 Hz Harmonic	0.0 to 999.9 V	1	64h	07h	7Ch	UINT	624	16bit	1
D4.1.3.2	120 Hz Harmonic	0.0 to 999.9 V	1	64h	07h	7Dh	UINT	625	16bit	1
D4.1.4	Control Voltages									
D4.1.4.1	Voltage 24V IO	0.00 to 655.35 V	2	64h	0Bh	68h	UINT	1004	16bit	1
D4.1.4.2	Battery Voltage	0.00 to 655.35 V	2	64h	0Bh	67h	UINT	1003	16bit	1
D4.1.4.3	Voltage 3.3V Control	0.00 to 655.35 V	2	64h	0Bh	69h	UINT	1005	16bit	1
D4.1.4.4	Voltage 24V Control	0.00 to 655.35 V	2	64h	0Bh	6Ah	UINT	1006	16bit	1
D4.1.4.5	Voltage 3.3V IO	0.00 to 655.35 V	2	64h	0Bh	6Bh	UINT	1007	16bit	1
D4.1.4.6	Voltage 5V AUI	0.00 to 655.35 V	2	64h	0Bh	66h	UINT	1002	16bit	1
D4.1.5	Motor Overl. Fault									
D4.1.5.1	lxt Motor Level	0 to 100 %	0	64h	01h	89h	UINT	37	16bit	1
D4.1.6	Thermal Management									
D4.1.6.1	IGBT Overload Status	0 = No Overload 1 = Slow Curve Overload 2 = Fast Curve 1 Overload		64h	0Dh	64h	USINT	1200	enum	1



Parameter	Description	Range of values	Decimal places	Class	Instance	Attribute	CIP data type	Net Id	Size	Qty mapped words
D4.1.6.2	IGBT Overload Counter	3 = Fast Curve 2 Overload 0.00 to 100.00 %	2	64h	0Dh	65h	UINT	1201	16bit	1
D4.1.6.3	Heatsink Temp.	0.00 to 655.35 °C	2	64h	1Fh	A3h	UINT	3063	16bit	1
D4.1.6.4	IGBT Junction Temp.	0.00 to 655.35 °C	2	64h	1Fh	A2h	UINT	3062	16bit	1
D4.1.6.5	Diode Junction Temp.	0.00 to 655.35 °C	2	64h	1Fh	A6h	UINT	3066	16bit	1
D4.2	Control Accessories									
D4.2.1	Diag. Slot A									
D4.2.1.1	Status	0 = Not Connected 1 = Initializing 2 = Active 3 = Error		64h	4Bh	64h	USINT	7400	enum	1
D4.2.1.2	Error Cause	0 = No Error 1 = Recognition Error 2 = Accessory Not Supported 3 = Initialization Error 4 = Not used 5 = Incorrect Accessory 6 = Disconnected 7 = Data Error 1 8 = Not used		64h	4Bh	65h	USINT	7401	enum	1
D4.2.1.3	Temperature	-100.0 to 250.0 °C	1	64h	4Bh	6Ah	INT	7406	s16bit	1
D4.2.2	Diag. Slot B									
D4.2.2.1	Status	0 = Not Connected 1 = Initializing 2 = Active 3 = Error		64h	4Eh	64h	USINT	7700	enum	1
D4.2.2.2	Error Cause	0 = No Error 1 = Recognition Error 2 = Accessory Not Supported 3 = Initialization Error 4 = Not used 5 = Incorrect Accessory 6 = Disconnected 7 = Data Error 1 8 = Not used		64h	4Eh	65h	USINT	7701	enum	1
D4.2.2.3	Temperature	-100.0 to 250.0 °C	1	64h	4Eh	6Ah	INT	7706	s16bit	1
D4.2.3	Diag. Slot C									
D4.2.3.1	Status	0 = Not Connected 1 = Initializing 2 = Active 3 = Error		64h	51h	64h	USINT	8000	enum	1
D4.2.3.2	Error Cause	0 = No Error 1 = Recognition Error		64h	51h	65h	USINT	8001	enum	1



Parameter	Description	Range of values	Decimal places	Class	Instance	Attribute	CIP data type	Net Id	Size	Qty mapped words
D4.2.3.3	Temperature	2 = Accessory Not Supported 3 = Initialization Error 4 = Not used 5 = Incorrect Accessory 6 = Disconnected 7 = Data Error 1 8 = Not used -100.0 to 250.0 °C	1	64h	51h	6Ah	INT	8006	s16bit	1
D4.2.4	Diag. Slot D									
D4.2.4.1	Status	0 = Not Connected 1 = Initializing 2 = Active 3 = Error		64h	54h	64h	USINT	8300	enum	1
D4.2.4.2	Error Cause	0 = No Error 1 = Recognition Error 2 = Accessory Not Supported 3 = Initialization Error 4 = Not used 5 = Incorrect Accessory 6 = Disconnected 7 = Data Error 1 8 = Not used		64h	54h	65h	USINT	8301	enum	1
D4.2.4.3	Temperature	-100.0 to 250.0 °C	1	64h	54h	6Ah	INT	8306	s16bit	1
D4.2.5	Diag. Slot E									
D4.2.5.1	Status	0 = Not Connected 1 = Initializing 2 = Active 3 = Error		64h	57h	64h	USINT	8600	enum	1
D4.2.5.2	Error Cause	0 = No Error 1 = Recognition Error 2 = Accessory Not Supported 3 = Initialization Error 4 = Not used 5 = Incorrect Accessory 6 = Disconnected 7 = Data Error 1 8 = Not used		64h	57h	65h	USINT	8601	enum	1
D4.2.5.3	Temperature	-100.0 to 250.0 °C	1	64h	57h	6Ah	INT	8606	s16bit	1
D4.2.6	Diag. Slot F									
D4.2.6.1	Status	0 = Not Connected 1 = Initializing 2 = Active 3 = Error		64h	5Ah	64h	USINT	8900	enum	1
D4.2.6.2	Error Cause			64h	5Ah	65h	USINT	8901	enum	1



Parameter	Description	Range of values	Decimal places	Class	Instance	Attribute	CIP data type	Net Id	Size	Qty mapped words
		0 = No Error 1 = Recognition Error 2 = Accessory Not Supported 3 = Initialization Error 4 = Not used 5 = Incorrect Accessory 6 = Disconnected 7 = Data Error 1 8 = Not used								
D4.2.6.3	Temperature	-100.0 to 250.0 °C	1	64h	5Ah	6Ah	INT	8906	s16bit	1
D4.2.7	Diag. Slot G									
D4.2.7.1	Status	0 = Not Connected 1 = Initializing 2 = Active 3 = Error		64h	5Dh	64h	USINT	9200	enum	1
D4.2.7.2	Error Cause	0 = No Error 1 = Recognition Error 2 = Accessory Not Supported 3 = Initialization Error 4 = Not used 5 = Incorrect Accessory 6 = Disconnected 7 = Data Error 1 8 = Not used		64h	5Dh	65h	USINT	9201	enum	1
D4.2.7.3	Temperature	-100.0 to 250.0 °C	1	64h	5Dh	6Ah	INT	9206	s16bit	1
D5 Diagnostics\Changed Parameters										
D5.1	Configuration									
D5.2	Application									
C1 Configuration\Inverter and Power Supply										
C1.1	Power Supply									
C1.1.1	Type	0 = Three-phase AC 1 = Single-phase AC 2 = DC		64h	0Dh	C2h	USINT	1294	enum	1
C1.1.2	Rated Voltage	1 to 1200 V	0	64h	0Dh	C4h	UINT	1296	16bit	1
C1.2	Inverter Use									
C1.2.1	Overload Type	0 = Normal Duty (ND) 1 = Heavy Duty (HD)		64h	0Dh	C6h	USINT	1298	enum	1
C1.3	Switching Frequency									
C1.3.1	User	1.0 to 16.0 kHz	1	64h	0Dh	C5h	UINT	1297	16bit	1
C1.3.2	Minimum	1.00 to 16.00 kHz	2	64h	1Fh	8Ah	UINT	3038	16bit	1
C1.4	PWM Modulation									
C1.4.1	Type	0 = Standard 1 = Not used		64h	29h	64h	USINT	4000	enum	1



Parameter	Description	Range of values	Decimal places	Class	Instance	Attribute	CIP data type	Net Id	Size	Qty mapped words
C1.4.4	PMW Wid. Adj. Long Cab.	2 = Modulation for Long Cable 0.00 to 1.00	2	64h	1Fh	A1h	UINT	3061	16bit	1
C1.4.5	Dead Time Compensation	0 = Disable 1 = Enable		64h	04h	9Ch	USINT	356	enum	1
C1.5	Fans Configuration									
C1.5.1	Power Fan Setting	0 = Off 1 = On 2 = Temp. Control w/ Init.Test 3 = Control by Temperature		64h	15h	64h	USINT	2000	enum	1
C1.5.2	Internal Fan Setting	0 = Off 1 = On 2 = Temp. Control w/ Init.Test 3 = Control by Temperature		64h	15h	65h	USINT	2001	enum	1
C1.6	Other Inverter Config.									
C1.6.1	Invert Output Phase Seq.	0 = U(T1)/V(T2)/W(T3) 1 = W(T3)/V(T2)/U(T1)		64h	1Fh	A0h	USINT	3060	enum	1
C1.6.2	Reset Counters	0 = Disabled 1 = Energy 2 = Fan On 3 = Inverter Enabled		64h	1Fh	93h	USINT	3047	enum	1
C1.6.3	User Delta Temp.	0.0 to 100.0 °C	1	64h	0Dh	C1h	INT	1293	s16bit	1
C1.6.4	Manual Inom Derating	0.0 to 100.0 %	1	64h	0Dh	C0h	UINT	1292	16bit	1
C2 Configuration\Motor										
C2.1	Motor Data									
C2.1.1	Motor Type	0 = Induction 1 = Permanent Magnet (PM)		64h	03h	69h	USINT	205	enum	1
C2.1.2	Motor Power Unit	0 = HP/cv 1 = kW		64h	05h	69h	USINT	405	enum	1
C2.1.3	Rated Power	0.0 to 2000.0	1	64h	05h	68h	UINT	404	16bit	1
C2.1.4	Rated Voltage	1 to 690 V	0	64h	05h	64h	UINT	400	16bit	1
C2.1.5	Rated Current	0.0 to 2223.0 A	1	64h	05h	65h	UINT	401	16bit	1
C2.1.6	Rated Frequency	1 to 500 Hz	0	64h	05h	67h	UINT	403	16bit	1
C2.1.7	Number of Pole Pairs	1 to 48	0	64h	05h	83h	UINT	431	16bit	1
C2.1.8	Rated Speed	0 to 18000 rpm	0	64h	05h	66h	UINT	402	16bit	1
C2.1.9	Rated Efficiency	50.0 to 99.9 %	1	64h	04h	C7h	UINT	399	16bit	1
C2.1.10	Rated cos phi	0.50 to 0.99	2	64h	05h	6Bh	UINT	407	16bit	1
C2.1.11	Service Factor	1.00 to 1.50	2	64h	04h	C6h	UINT	398	16bit	1
C2.1.12	Ventilation	0 = Self-ventilated 1 = Independent		64h	05h	6Ah	USINT	406	enum	1
C2.2	Motor Model Parameters									
C2.2.1	Stator Resistance	0.000 to 10.000 Ω	3	64h	05h	6Dh	UINT	409	16bit	1



Parameter	Description	Range of values	Decimal places	Class	Instance	Attribute	CIP data type	Net Id	Size	Qty mapped words
C2.2.2	Magnetization Reactance	0.0 to 500.0 Ω	1	64h	05h	6Eh	UINT	410	16bit	1
C2.2.3	Leakage Reactance	0.00 to 50.00 Ω	2	64h	05h	6Fh	UINT	411	16bit	1
C2.2.4	Rotor Resistance	0.000 to 10.000 Ω	3	64h	05h	70h	UINT	412	16bit	1
C2.2.5	Rotor Reactance	0.00 to 50.00 Ω	2	64h	05h	71h	UINT	413	16bit	1
C2.2.8	Ke Constant	0.0 to 2000.0	1	64h	05h	87h	UINT	435	16bit	1
C3 Configuration/Control										
C3.1	Configuration									
C3.1.1	Control Type	0 = Scalar 1 = VVW+ 2 = Encoder Vector 3 = Sensorless Vector		64h	03h	66h	USINT	202	enum	1
C3.2	Scalar (V/F) and VVW+ Control									
C3.2.1	V/F Curve									
C3.2.1.1	Manual Torque Boost	0.0 to 20.0 %	1	64h	02h	88h	REAL	136	TIME	2
C3.2.1.2	Low Output Voltage	0.0 to 100.0 %	1	64h	02h	90h	REAL	144	TIME	2
C3.2.1.3	Interm. Output Voltage	0.0 to 100.0 %	1	64h	02h	8Fh	REAL	143	TIME	2
C3.2.1.4	Maximum Output Voltage	0.0 to 100.0 %	1	64h	02h	8Eh	REAL	142	TIME	2
C3.2.1.5	Low Speed	0.0 to 200.0 %	1	64h	02h	93h	UINT	147	16bit	1
C3.2.1.6	Intermediate Speed	0.0 to 200.0 %	1	64h	02h	92h	UINT	146	16bit	1
C3.2.1.7	Field Weakening Start Speed	0.0 to 200.0 %	1	64h	02h	91h	UINT	145	16bit	1
C3.2.1.8	Rated Flux	0.0 to 120.0 %	1	64h	02h	94h	REAL	148	TIME	2
C3.2.2	VVW+ Optimization									
C3.2.2.1.1	Slip Compensator Gain	0.00 to 10.00	2	64h	1Fh	7Ah	UINT	3022	16bit	1
C3.2.2.1.2	Voltage Comp. Gain	0.00 to 5.00	2	64h	1Fh	7Bh	UINT	3023	16bit	1
C3.2.2.1.3	Cut freq. of Slip Filter	1 to 100 Hz	0	64h	1Fh	BCh	UINT	3088	16bit	1
C3.2.2.2.1	MTPA Function	0 = Disable 1 = Enable		64h	07h	77h	USINT	619	enum	1
C3.2.2.2.2	MTPA Optimizer	0 = Disable 1 = Enable		64h	07h	71h	USINT	613	enum	1
C3.2.2.2.3	MTPA Minimum Speed	0 to 100 %	0	64h	07h	76h	UINT	618	16bit	1
C3.2.2.2.4	Efficiency Adjustment Gain	0.000 to 4.000	3	64h	07h	78h	UINT	620	16bit	1
C3.2.2.2.5	Kp MTPA Gain	0.000 to 1.000	3	64h	07h	75h	UINT	617	16bit	1
C3.2.2.2.6	Ki MTPA Gain	0.000 to 1.000	3	64h	07h	74h	UINT	616	16bit	1
C3.2.2.2.7	MTPA Reference	0 to 100 %	0	64h	07h	73h	INT	615	s16bit	1
C3.2.2.2.8	MTPA Minimum Voltage	0 to 100 %	0	64h	07h	72h	UINT	614	16bit	1
C3.2.3	Current Stabilization									
C3.2.3.1	Enable Function	0 = Disable 1 = Enable		64h	04h	9Fh	USINT	359	enum	1
C3.2.3.2	Stabilization Kp Gain	0.000 to 1.999	3	64h	07h	79h	UINT	621	16bit	1
C3.2.3.3	Stabilization Ki Gain	0.000 to 1.999	3	64h	07h	7Ah	UINT	622	16bit	1
C3.2.3.4	Stab. PI Saturation	0.0 to 10.0 %	1	64h	07h	7Bh	UINT	623	16bit	1
C3.2.3.5	Max. Operation Freq.	0 to 300 %	0	64h	1Fh	A7h	UINT	3067	16bit	1
C3.2.4	Pre-Magnetization									
C3.2.4.1	Enable Function			64h	1Fh	B1h	USINT	3077	enum	1



Parameter	Description	Range of values	Decimal places	Class	Instance	Attribute	CIP data type	Net Id	Size	Qty mapped words
C3.2.4.2	Current	0 = Disable 1 = Enable	0	64h	1Fh	7Dh	UINT	3025	16bit	1
C3.2.4.3	Time	0 to 350 %	0	64h	1Fh	7Ch	UINT	3024	16bit	1
C3.2.4.4	Gain	0 to 5000 ms	0	64h	1Fh	7Fh	UINT	3027	16bit	1
C3.2.4.4	Gain	1.0 to 7.0	1	64h	1Fh	7Fh	UINT	3027	16bit	1
C3.2.5	I/F Control									
C3.2.5.1	Enabled	0 = Disable 1 = Enable		64h	1Fh	C1h	USINT	3093	enum	1
C3.2.5.2	Enable on Reversal	0 = Disable 1 = Enable		64h	1Fh	C7h	USINT	3099	enum	1
C3.2.5.3	Current	0 to 200 %	0	64h	1Fh	C2h	UINT	3094	16bit	1
C3.2.5.4	Transition Speed	0 to 100 %	0	64h	1Fh	C3h	UINT	3095	16bit	1
C3.2.5.5	Drag Time	0 to 10 s	0	64h	1Fh	C4h	UINT	3096	16bit	1
C3.2.5.6	Kick-off Speed	0 to 50 %	0	64h	1Fh	C5h	UINT	3097	16bit	1
C3.3	Vector Control									
C3.3.1	Configuration									
C3.3.1.1	Control Mode	0 = Speed 1 = Torque 2 = Defined by DI		64h	1Fh	64h	USINT	3000	enum	1
C3.3.1.2	Control Mode DI Config.	0 = Inactive 1 = DI X-1 2 = DI X-2 3 = DI X-3 4 = DI X-4 5 = DI X-5 6 = DI X-6 7 = DI A-1 8 = DI A-2 9 = DI A-3 10 = DI A-4 11 = DI A-5 12 = DI A-6 13 = DI A-7 14 = DI A-8 15 = DI B-1 16 = DI B-2 17 = DI B-3 18 = DI B-4 19 = DI B-5 20 = DI B-6 21 = DI B-7 22 = DI B-8 23 = DI C-1 24 = DI C-2 25 = DI C-3 26 = DI C-4		64h	1Fh	65h	USINT	3001	enum	1



Parameter	Description	Range of values	Decimal places	Class	Instance	Attribute	CIP data type	Net Id	Size	Qty mapped words
		27 = DI C-5 28 = DI C-6 29 = DI C-7 30 = DI C-8 31 = DI D-1 32 = DI D-2 33 = DI D-3 34 = DI D-4 35 = DI D-5 36 = DI D-6 37 = DI D-7 38 = DI D-8 39 = DI E-1 40 = DI E-2 41 = DI E-3 42 = DI E-4 43 = DI E-5 44 = DI E-6 45 = DI E-7 46 = DI E-8 47 = DI F-1 48 = DI F-2 49 = DI F-3 50 = DI F-4 51 = DI F-5 52 = DI F-6 53 = DI F-7 54 = DI F-8 55 = DI G-1 56 = DI G-2 57 = DI G-3 58 = DI G-4 59 = DI G-5 60 = DI G-6 61 = DI G-7 62 = DI G-8								
C3.3.1.3	Control Encoder	0 = Slot X 1 = Slot A 2 = Slot B 3 = Slot C 4 = Slot D 5 = Slot E 6 = Slot F 7 = Slot G 8 = None		64h	1Fh	75h	USINT	3017	enum	1
C3.3.1.6	Magnetization Mode	0 = General Enable 1 = Run/Stop		64h	02h	B5h	USINT	181	enum	1
C3.3.2	Regulators									



Parameter	Description	Range of values	Decimal places	Class	Instance	Attribute	CIP data type	Net Id	Size	Qty mapped words
C3.3.2.1.1	Adaptive Gain	0 = Disable 1 = Enable		64h	02h	A0h	USINT	160	enum	1
C3.3.2.1.2	Proportional Gain	0.0 to 50.0	1	64h	02h	A1h	UINT	161	16bit	1
C3.3.2.1.3	Integral Gain	0.001 to 1.000	3	64h	02h	A2h	UINT	162	16bit	1
C3.3.2.1.4	Differential Gain	0.00 to 7.99	2	64h	02h	A6h	UINT	166	16bit	1
C3.3.2.1.5	Filter	0.012 to 1.000 s	3	64h	02h	A5h	UINT	165	16bit	1
C3.3.2.2.1	Proportional Gain	0.00 to 5.00	2	64h	1Fh	66h	UINT	3002	16bit	1
C3.3.2.2.2	Integral Gain	0.000 to 1.000	3	64h	1Fh	67h	UINT	3003	16bit	1
C3.3.2.2.3	Differential Gain	0.00 to 7.99	2	64h	1Fh	B8h	UINT	3084	16bit	1
C3.3.2.2.4	Filter	0.012 to 10.000	3	64h	1Fh	74h	UINT	3016	16bit	1
C3.3.2.3.1	Proportional Gain	0.0 to 5.0	1	64h	02h	AFh	UINT	175	16bit	1
C3.3.2.3.2	Integral Gain	0.000 to 1.000	3	64h	02h	B0h	UINT	176	16bit	1
C3.3.2.3.3	Rated Flux	0.0 to 120.0 %	1	64h	02h	B2h	UINT	178	16bit	1
C3.3.2.4.1	Id Prop. Gain	0.00 to 1.99	2	64h	05h	8Ch	UINT	440	16bit	1
C3.3.2.4.2	Id Integral Gain	0.001 to 1.000	3	64h	05h	8Dh	UINT	441	16bit	1
C3.3.2.4.3	Iq Prop. Gain	0.00 to 1.99	2	64h	05h	8Ah	UINT	438	16bit	1
C3.3.2.4.4	Iq Integral Gain	0.001 to 1.000	3	64h	05h	8Bh	UINT	439	16bit	1
C3.3.3	Output Voltage Limiter									
C3.3.3.1	Maximum Output Voltage	0.0 to 120.0 %	1	64h	02h	BEh	UINT	190	16bit	1
C3.3.3.2	Proportional Gain	0.00 to 5.00	2	64h	1Fh	82h	UINT	3030	16bit	1
C3.3.3.3	Integral Gain	0.000 to 1.000	3	64h	1Fh	83h	UINT	3031	16bit	1
C3.3.4	Torque Mode									
C3.3.4.1.1	Direct Speed	0 to 32000 rpm	0	64h	02h	ABh	UINT	171	16bit	1
C3.3.4.1.2	Reverse Speed	0 to 32000 rpm	0	64h	02h	ACH	UINT	172	16bit	1
C3.3.4.1.3	Proportional Gain	0.00 to 5.00	2	64h	1Fh	8Fh	UINT	3043	16bit	1
C3.3.4.1.4	Integral Gain	0.000 to 1.000	3	64h	1Fh	90h	UINT	3044	16bit	1
C3.3.5	Speed Mode									
C3.3.5.1.1	Global Torque	0.0 to 400.0 %	1	64h	1Fh	73h	UINT	3015	16bit	1
C3.3.5.1.2	Torque Q1	0.0 to 400.0 %	1	64h	02h	A9h	UINT	169	16bit	1
C3.3.5.1.3	Torque Q2	0.0 to 400.0 %	1	64h	02h	AAh	UINT	170	16bit	1
C3.3.5.1.4	Torque Q3	0.0 to 400.0 %	1	64h	1Fh	71h	UINT	3013	16bit	1
C3.3.5.1.5	Torque Q4	0.0 to 400.0 %	1	64h	1Fh	72h	UINT	3014	16bit	1
C3.3.5.1.6	Global Torque AI Config.	0 = Inactive 1 = AI X-1 2 = AI X-2 3 = AI A-1 4 = AI A-2 5 = AI A-3 6 = Not used 7 = AI B-1 8 = AI B-2 9 = AI B-3 10 = Not used 11 = AI C-1 12 = AI C-2 13 = AI C-3 14 = Not used 15 = AI D-1		64h	1Fh	6Fh	USINT	3011	enum	1



Parameter	Description	Range of values	Decimal places	Class	Instance	Attribute	CIP data type	Net Id	Size	Qty mapped words
		16 = AI D-2 17 = AI D-3 18 = Not used 19 = AI E-1 20 = AI E-2 21 = AI E-3 22 = Not used 23 = AI F-1 24 = AI F-2 25 = AI F-3 26 = Not used 27 = AI G-1 28 = AI G-2 29 = AI G-3 30 = Not used								
C3.3.5.1.7	Proportional Gain	0.00 to 5.00	2	64h	1Fh	84h	UINT	3032	16bit	1
C3.3.5.1.8	Integral Gain	0.00 to 100.00	2	64h	1Fh	85h	UINT	3033	16bit	1
C3.3.7	Speed Steady State Estimator									
C3.3.7.1	Speed Setting	0.10 to 10.00	2	64h	1Fh	B3h	UINT	3079	16bit	1
C3.3.7.2	Regenerative Compensator	0.00 to 2.00	2	64h	1Fh	9Fh	UINT	3059	16bit	1
C3.3.7.3	Proportional Gain	0.00 to 10.00	2	64h	1Fh	99h	UINT	3053	16bit	1
C3.3.7.4	Integral Gain	0.00 to 10.00	2	64h	1Fh	9Ah	UINT	3054	16bit	1
C3.3.7.5	Filter.	1 to 15 ms	0	64h	1Fh	B7h	UINT	3083	16bit	1
C3.3.9	Online Parameter Estimation									
C3.3.9.1	Estimator Configuration	Bit 0 = Enable Xm Estimator Bit 1 = Enable Taus Estimator Bit 2 = Enable Taur Estimator		64h	1Fh	9Eh	WORD	3058	3bit	1
C3.4	Current Limiter									
C3.4.1	Actuation Level	0 to 300 %	0	64h	02h	87h	UINT	135	16bit	1
C3.4.3	Proportional Gain	0.0 to 5.0	1	64h	1Fh	86h	UINT	3034	16bit	1
C3.4.4	Integral Gain	0.0 to 5.0	1	64h	1Fh	87h	UINT	3035	16bit	1
C3.5	DC Link Voltage Limiter									
C3.5.1	DC Link Volt.Limit.Config.									
C3.5.1.1	Enable Function	0 = Disable 1 = Enable		64h	1Fh	81h	USINT	3029	enum	1
C3.5.2	Scalar and VVW+ Control									
C3.5.2.1	DC Link Volt. Lim.-Level	114.0 to 160.0 %	1	64h	02h	97h	UINT	151	16bit	1
C3.5.2.2	DC Link Volt.Lim.-Kp Gain	0.00 to 9.99	2	64h	02h	98h	UINT	152	16bit	1
C3.5.2.3	DC Link Volt.Lim.-Ki Gain	0.000 to 1.000	3	64h	1Fh	76h	UINT	3018	16bit	1
C3.5.2.4	DC Link Volt.Lim.-Est.Gain	0.000 to 9.999	3	64h	1Fh	7Eh	INT	3026	s16bit	1
C3.5.3	Vector Control									
C3.5.3.1	Optim. Braking Func. Enable	0 = No 1 = Yes		64h	02h	B8h	USINT	184	enum	1
C3.5.3.2	DC Link Volt.Lim.-Level	114.0 to 160.0 %	1	64h	02h	B9h	UINT	185	16bit	1
C3.5.3.3	DC Link Volt.Lim.-Kp Gain	0.00 to 6.39	2	64h	02h	BAh	UINT	186	16bit	1
C3.5.3.4	DC Link Volt.Lim.-Ki Gain	0.000 to 1.000	3	64h	02h	BBh	UINT	187	16bit	1



Parameter	Description	Range of values	Decimal places	Class	Instance	Attribute	CIP data type	Net Id	Size	Qty mapped words
C3.6	Dynamic Braking									
C3.6.1	DC Link Voltage Level	0.1 to 100.0 %	1	64h	02h	99h	UINT	153	16bit	1
C3.7	DC braking									
C3.7.1	Enable Function	0 = Disable 1 = Only Start 2 = Only Stop 3 = Start and Stop 4 = Always Enabled		64h	04h	6Bh	USINT	307	enum	1
C3.7.2	DC-Braking Start Time	0.0 to 15.0 s	1	64h	03h	C7h	UINT	299	16bit	1
C3.7.3	DC-Braking Stop Time	0.0 to 15.0 s	1	64h	04h	64h	UINT	300	16bit	1
C3.7.4	Starting Speed	0 to 450 rpm	0	64h	04h	65h	UINT	301	16bit	1
C3.7.5	Current	0.0 to 100.0 %	1	64h	04h	66h	UINT	302	16bit	1
C3.8	Flying Start									
C3.8.1	Flying Start Setting									
C3.8.1.1	Enable Function	0 = Disable 1 = Enable		64h	1Fh	6Ch	USINT	3008	enum	1
C3.8.1.2	Function Reset	0 = General Enable 1 = Run/Stop		64h	04h	7Fh	USINT	327	enum	1
C3.8.1.3	Tracking	0 = Two Trackings 1 = One Tracking		64h	04h	80h	USINT	328	enum	1
C3.8.1.4	Ramp	0.2 to 60.0 s	1	64h	04h	83h	UINT	331	16bit	1
C3.8.1.5	Disable Flying Start	0 = Inactive 1 = DI X-1 2 = DI X-2 3 = DI X-3 4 = DI X-4 5 = DI X-5 6 = DI X-6 7 = DI A-1 8 = DI A-2 9 = DI A-3 10 = DI A-4 11 = DI A-5 12 = DI A-6 13 = DI A-7 14 = DI A-8 15 = DI B-1 16 = DI B-2 17 = DI B-3 18 = DI B-4 19 = DI B-5 20 = DI B-6 21 = DI B-7 22 = DI B-8		64h	3Dh	70h	USINT	6012	enum	1



Parameter	Description	Range of values	Decimal places	Class	Instance	Attribute	CIP data type	Net Id	Size	Qty mapped words
		23 = DI C-1 24 = DI C-2 25 = DI C-3 26 = DI C-4 27 = DI C-5 28 = DI C-6 29 = DI C-7 30 = DI C-8 31 = DI D-1 32 = DI D-2 33 = DI D-3 34 = DI D-4 35 = DI D-5 36 = DI D-6 37 = DI D-7 38 = DI D-8 39 = DI E-1 40 = DI E-2 41 = DI E-3 42 = DI E-4 43 = DI E-5 44 = DI E-6 45 = DI E-7 46 = DI E-8 47 = DI F-1 48 = DI F-2 49 = DI F-3 50 = DI F-4 51 = DI F-5 52 = DI F-6 53 = DI F-7 54 = DI F-8 55 = DI G-1 56 = DI G-2 57 = DI G-3 58 = DI G-4 59 = DI G-5 60 = DI G-6 61 = DI G-7 62 = DI G-8								
C3.8.2	Scalar and VVW+ Control									
C3.8.2.1	Current	0.0 to 100.0 %	1	64h	04h	84h	UINT	332	16bit	1
C3.8.3	Vector Control									
C3.8.3.1	Flux Reference	0.0 to 100.0 %	1	64h	04h	81h	REAL	329	TIME	2
C3.9	Ride-Through									
C3.9.1	Ride-Through Config.									
C3.9.1.1	Function Enable	0 = Disable 1 = Enable		64h	04h	78h	USINT	320	enum	1
C3.9.2	Scalar and VVW+ Control									



Parameter	Description	Range of values	Decimal places	Class	Instance	Attribute	CIP data type	Net Id	Size	Qty mapped words
C3.9.2.1	DC Link Volt.-Ride-Through	76.0 to 95.0 %	1	64h	1Fh	79h	UINT	3021	16bit	1
C3.9.2.2	Ride-Through-Gain Kp	0.00 to 2.00	2	64h	1Fh	77h	UINT	3019	16bit	1
C3.9.2.3	Ride-Through-Gain Ki	0.000 to 1.000	3	64h	1Fh	78h	UINT	3020	16bit	1
C3.9.3	Vector Control									
C3.9.3.1	DC Link Volt.-Ride-Through	76.0 to 95.0 %	1	64h	04h	7Ah	UINT	322	16bit	1
C3.9.3.2	Ride-Through-Gain Kp	0.00 to 2.00	2	64h	04h	7Dh	UINT	325	16bit	1
C3.9.3.3	Ride-Through-Gain Ki	0.000 to 1.000	3	64h	04h	7Eh	UINT	326	16bit	1
C3.10	Advanced Energy Saving									
C3.10.1	Enable Function	0 = Disable 1 = Enable		64h	1Fh	80h	USINT	3028	enum	1
C3.10.2	Adv. Optimum Flux Config.	0 = Disable 1 = Enable		64h	06h	C0h	USINT	592	enum	1
C3.10.3	Cos phi Reference	0.50 to 0.99	2	64h	1Fh	6Dh	INT	3009	s16bit	1
C3.10.4	Maximum Torque	0 to 150 %	0	64h	06h	BCh	INT	588	s16bit	1
C3.10.5	Minimum Voltage	40 to 80 %	0	64h	06h	BDh	INT	589	s16bit	1
C3.10.6	Minimum Speed	0 to 100 %	0	64h	06h	BEh	INT	590	s16bit	1
C3.10.7	Torque Hysteresis	0 to 30 %	0	64h	06h	BFh	INT	591	s16bit	1
C4 Configuration\Commands and References										
C4.1	LOC/REM Mode Config.									
C4.1.1	Command mode	0 = Always Local 1 = Remote 1 2 = Remote 2 3 = Serial 4 = Not used 5 = CAN/CO/DN 6 = SoftPLC 7 = Not used 8 = Ethernet 9 = Digital Input (DI)		64h	03h	78h	USINT	220	enum	1
C4.1.2	DI Remote 1/Remote 2	0 = Inactive 1 = DI X-1 2 = DI X-2 3 = DI X-3 4 = DI X-4 5 = DI X-5 6 = DI X-6 7 = DI A-1 8 = DI A-2 9 = DI A-3 10 = DI A-4 11 = DI A-5 12 = DI A-6 13 = DI A-7 14 = DI A-8 15 = DI B-1		64h	3Dh	6Fh	USINT	6011	enum	1



Parameter	Description	Range of values	Decimal places	Class	Instance	Attribute	CIP data type	Net Id	Size	Qty mapped words	
		16 = DI B-2 17 = DI B-3 18 = DI B-4 19 = DI B-5 20 = DI B-6 21 = DI B-7 22 = DI B-8 23 = DI C-1 24 = DI C-2 25 = DI C-3 26 = DI C-4 27 = DI C-5 28 = DI C-6 29 = DI C-7 30 = DI C-8 31 = DI D-1 32 = DI D-2 33 = DI D-3 34 = DI D-4 35 = DI D-5 36 = DI D-6 37 = DI D-7 38 = DI D-8 39 = DI E-1 40 = DI E-2 41 = DI E-3 42 = DI E-4 43 = DI E-5 44 = DI E-6 45 = DI E-7 46 = DI E-8 47 = DI F-1 48 = DI F-2 49 = DI F-3 50 = DI F-4 51 = DI F-5 52 = DI F-6 53 = DI F-7 54 = DI F-8 55 = DI G-1 56 = DI G-2 57 = DI G-3 58 = DI G-4 59 = DI G-5 60 = DI G-6 61 = DI G-7 62 = DI G-8									
C4.1.3	HMI LOC/REM key	0 = Disable 1 = Enable		64h	63h	67h	USINT	9803	enum	1	



Parameter	Description	Range of values	Decimal places	Class	Instance	Attribute	CIP data type	Net Id	Size	Qty mapped words
C4.2	Commands									
C4.2.1	R1 Config. Commands									
C4.2.1.1	General Enable	0 = Always enabled 1 = HMI 2 = Serial 3 = Not used 4 = CAN/CO/DN 5 = SoftPLC 6 = Not used 7 = Ethernet 8 = Digital Input (DI)		64h	03h	8Ch	USINT	240	enum	1
C4.2.1.2	Run/Stop	0 = HMI I/O Keys 1 = Serial 2 = Not used 3 = CAN/CO/DN 4 = SoftPLC 5 = Not used 6 = Ethernet 7 = Run/Stop DI 8 = Forward/Reverse DI 9 = 3-Wire Start/Stop DI		64h	03h	7Ch	USINT	224	enum	1
C4.2.1.3	Direction of Rotation	0 = Forward 1 = HMI DR key 2 = Serial 3 = Not used 4 = CAN/CO/DN 5 = SoftPLC 6 = Not used 7 = Ethernet 8 = Direction of Rotation DI 9 = Forward/Reverse DI 10 = Speed Reference		64h	03h	7Bh	USINT	223	enum	1
C4.2.1.4	JOG	0 = Inactive 1 = HMI JOG Key 2 = Serial 3 = Not used 4 = CAN/CO/DN 5 = SoftPLC 6 = Not used 7 = Ethernet 8 = Digital Input (DI)		64h	03h	7Dh	USINT	225	enum	1
C4.2.2	R2 Config. Commands									
C4.2.2.1	General Enable	0 = Always enabled 1 = HMI 2 = Serial		64h	03h	8Dh	USINT	241	enum	1



Parameter	Description	Range of values	Decimal places	Class	Instance	Attribute	CIP data type	Net Id	Size	Qty mapped words
		3 = Not used 4 = CAN/CO/DN 5 = SoftPLC 6 = Not used 7 = Ethernet 8 = Digital Input (DI)								
C4.2.2.2	Run/Stop	0 = HMI I/O Keys 1 = Serial 2 = Not used 3 = CAN/CO/DN 4 = SoftPLC 5 = Not used 6 = Ethernet 7 = Run/Stop DI 8 = Forward/Reverse DI 9 = 3-Wire Start/Stop DI		64h	03h	7Fh	USINT	227	enum	1
C4.2.2.3	Direction of Rotation	0 = Forward 1 = HMI DR key 2 = Serial 3 = Not used 4 = CAN/CO/DN 5 = SoftPLC 6 = Not used 7 = Ethernet 8 = Direction of Rotation DI 9 = Forward/Reverse DI 10 = Speed Reference		64h	03h	7Eh	USINT	226	enum	1
C4.2.2.4	JOG	0 = Inactive 1 = HMI JOG Key 2 = Serial 3 = Not used 4 = CAN/CO/DN 5 = SoftPLC 6 = Not used 7 = Ethernet 8 = Digital Input (DI)		64h	03h	80h	USINT	228	enum	1
C4.2.3	DIs Config. for Commands									
C4.2.3.1	General Enable	0 = Inactive 1 = DI X-1 2 = DI X-2 3 = DI X-3 4 = DI X-4 5 = DI X-5 6 = DI X-6 7 = DI A-1 8 = DI A-2		64h	3Dh	64h	USINT	6000	enum	1



Parameter	Description	Range of values	Decimal places	Class	Instance	Attribute	CIP data type	Net Id	Size	Qty mapped words	
		9 = DI A-3 10 = DI A-4 11 = DI A-5 12 = DI A-6 13 = DI A-7 14 = DI A-8 15 = DI B-1 16 = DI B-2 17 = DI B-3 18 = DI B-4 19 = DI B-5 20 = DI B-6 21 = DI B-7 22 = DI B-8 23 = DI C-1 24 = DI C-2 25 = DI C-3 26 = DI C-4 27 = DI C-5 28 = DI C-6 29 = DI C-7 30 = DI C-8 31 = DI D-1 32 = DI D-2 33 = DI D-3 34 = DI D-4 35 = DI D-5 36 = DI D-6 37 = DI D-7 38 = DI D-8 39 = DI E-1 40 = DI E-2 41 = DI E-3 42 = DI E-4 43 = DI E-5 44 = DI E-6 45 = DI E-7 46 = DI E-8 47 = DI F-1 48 = DI F-2 49 = DI F-3 50 = DI F-4 51 = DI F-5 52 = DI F-6 53 = DI F-7 54 = DI F-8 55 = DI G-1 56 = DI G-2 57 = DI G-3 58 = DI G-4 59 = DI G-5									



Parameter	Description	Range of values	Decimal places	Class	Instance	Attribute	CIP data type	Net Id	Size	Qty mapped words
C4.2.3.2	Run/Stop	60 = DI G-6 61 = DI G-7 62 = DI G-8 0 = Inactive 1 = DI X-1 2 = DI X-2 3 = DI X-3 4 = DI X-4 5 = DI X-5 6 = DI X-6 7 = DI A-1 8 = DI A-2 9 = DI A-3 10 = DI A-4 11 = DI A-5 12 = DI A-6 13 = DI A-7 14 = DI A-8 15 = DI B-1 16 = DI B-2 17 = DI B-3 18 = DI B-4 19 = DI B-5 20 = DI B-6 21 = DI B-7 22 = DI B-8 23 = DI C-1 24 = DI C-2 25 = DI C-3 26 = DI C-4 27 = DI C-5 28 = DI C-6 29 = DI C-7 30 = DI C-8 31 = DI D-1 32 = DI D-2 33 = DI D-3 34 = DI D-4 35 = DI D-5 36 = DI D-6 37 = DI D-7 38 = DI D-8 39 = DI E-1 40 = DI E-2 41 = DI E-3 42 = DI E-4 43 = DI E-5 44 = DI E-6 45 = DI E-7 46 = DI E-8		64h	3Dh	68h	USINT	6004	enum	1



Parameter	Description	Range of values	Decimal places	Class	Instance	Attribute	CIP data type	Net Id	Size	Qty mapped words
C4.2.3.3	3-Wire Start	47 = DI F-1 48 = DI F-2 49 = DI F-3 50 = DI F-4 51 = DI F-5 52 = DI F-6 53 = DI F-7 54 = DI F-8 55 = DI G-1 56 = DI G-2 57 = DI G-3 58 = DI G-4 59 = DI G-5 60 = DI G-6 61 = DI G-7 62 = DI G-8								
		0 = Inactive 1 = DI X-1 2 = DI X-2 3 = DI X-3 4 = DI X-4 5 = DI X-5 6 = DI X-6 7 = DI A-1 8 = DI A-2 9 = DI A-3 10 = DI A-4 11 = DI A-5 12 = DI A-6 13 = DI A-7 14 = DI A-8 15 = DI B-1 16 = DI B-2 17 = DI B-3 18 = DI B-4 19 = DI B-5 20 = DI B-6 21 = DI B-7 22 = DI B-8 23 = DI C-1 24 = DI C-2 25 = DI C-3 26 = DI C-4 27 = DI C-5 28 = DI C-6 29 = DI C-7 30 = DI C-8 31 = DI D-1 32 = DI D-2 33 = DI D-3		64h	3Dh	69h	USINT	6005	enum	1



Parameter	Description	Range of values	Decimal places	Class	Instance	Attribute	CIP data type	Net Id	Size	Qty mapped words	
		34 = DI D-4 35 = DI D-5 36 = DI D-6 37 = DI D-7 38 = DI D-8 39 = DI E-1 40 = DI E-2 41 = DI E-3 42 = DI E-4 43 = DI E-5 44 = DI E-6 45 = DI E-7 46 = DI E-8 47 = DI F-1 48 = DI F-2 49 = DI F-3 50 = DI F-4 51 = DI F-5 52 = DI F-6 53 = DI F-7 54 = DI F-8 55 = DI G-1 56 = DI G-2 57 = DI G-3 58 = DI G-4 59 = DI G-5 60 = DI G-6 61 = DI G-7 62 = DI G-8									
C4.2.3.4	3-Wire Stop	0 = Inactive 1 = DI X-1 2 = DI X-2 3 = DI X-3 4 = DI X-4 5 = DI X-5 6 = DI X-6 7 = DI A-1 8 = DI A-2 9 = DI A-3 10 = DI A-4 11 = DI A-5 12 = DI A-6 13 = DI A-7 14 = DI A-8 15 = DI B-1 16 = DI B-2 17 = DI B-3 18 = DI B-4 19 = DI B-5 20 = DI B-6		64h	3Dh	6Ah	USINT	6006	enum	1	



Parameter	Description	Range of values	Decimal places	Class	Instance	Attribute	CIP data type	Net Id	Size	Qty mapped words	
		21 = DI B-7 22 = DI B-8 23 = DI C-1 24 = DI C-2 25 = DI C-3 26 = DI C-4 27 = DI C-5 28 = DI C-6 29 = DI C-7 30 = DI C-8 31 = DI D-1 32 = DI D-2 33 = DI D-3 34 = DI D-4 35 = DI D-5 36 = DI D-6 37 = DI D-7 38 = DI D-8 39 = DI E-1 40 = DI E-2 41 = DI E-3 42 = DI E-4 43 = DI E-5 44 = DI E-6 45 = DI E-7 46 = DI E-8 47 = DI F-1 48 = DI F-2 49 = DI F-3 50 = DI F-4 51 = DI F-5 52 = DI F-6 53 = DI F-7 54 = DI F-8 55 = DI G-1 56 = DI G-2 57 = DI G-3 58 = DI G-4 59 = DI G-5 60 = DI G-6 61 = DI G-7 62 = DI G-8									
C4.2.3.5	Forward	0 = Inactive 1 = DI X-1 2 = DI X-2 3 = DI X-3 4 = DI X-4 5 = DI X-5 6 = DI X-6 7 = DI A-1		64h	3Dh	6Bh	USINT	6007	enum	1	



Parameter	Description	Range of values	Decimal places	Class	Instance	Attribute	CIP data type	Net Id	Size	Qty mapped words	
		8 = DI A-2 9 = DI A-3 10 = DI A-4 11 = DI A-5 12 = DI A-6 13 = DI A-7 14 = DI A-8 15 = DI B-1 16 = DI B-2 17 = DI B-3 18 = DI B-4 19 = DI B-5 20 = DI B-6 21 = DI B-7 22 = DI B-8 23 = DI C-1 24 = DI C-2 25 = DI C-3 26 = DI C-4 27 = DI C-5 28 = DI C-6 29 = DI C-7 30 = DI C-8 31 = DI D-1 32 = DI D-2 33 = DI D-3 34 = DI D-4 35 = DI D-5 36 = DI D-6 37 = DI D-7 38 = DI D-8 39 = DI E-1 40 = DI E-2 41 = DI E-3 42 = DI E-4 43 = DI E-5 44 = DI E-6 45 = DI E-7 46 = DI E-8 47 = DI F-1 48 = DI F-2 49 = DI F-3 50 = DI F-4 51 = DI F-5 52 = DI F-6 53 = DI F-7 54 = DI F-8 55 = DI G-1 56 = DI G-2 57 = DI G-3 58 = DI G-4									



Parameter	Description	Range of values	Decimal places	Class	Instance	Attribute	CIP data type	Net Id	Size	Qty mapped words
C4.2.3.6	Reverse	59 = DI G-5 60 = DI G-6 61 = DI G-7 62 = DI G-8 0 = Inactive 1 = DI X-1 2 = DI X-2 3 = DI X-3 4 = DI X-4 5 = DI X-5 6 = DI X-6 7 = DI A-1 8 = DI A-2 9 = DI A-3 10 = DI A-4 11 = DI A-5 12 = DI A-6 13 = DI A-7 14 = DI A-8 15 = DI B-1 16 = DI B-2 17 = DI B-3 18 = DI B-4 19 = DI B-5 20 = DI B-6 21 = DI B-7 22 = DI B-8 23 = DI C-1 24 = DI C-2 25 = DI C-3 26 = DI C-4 27 = DI C-5 28 = DI C-6 29 = DI C-7 30 = DI C-8 31 = DI D-1 32 = DI D-2 33 = DI D-3 34 = DI D-4 35 = DI D-5 36 = DI D-6 37 = DI D-7 38 = DI D-8 39 = DI E-1 40 = DI E-2 41 = DI E-3 42 = DI E-4 43 = DI E-5 44 = DI E-6 45 = DI E-7		64h	3Dh	6Ch	USINT	6008	enum	1



Parameter	Description	Range of values	Decimal places	Class	Instance	Attribute	CIP data type	Net Id	Size	Qty mapped words
		46 = DI E-8 47 = DI F-1 48 = DI F-2 49 = DI F-3 50 = DI F-4 51 = DI F-5 52 = DI F-6 53 = DI F-7 54 = DI F-8 55 = DI G-1 56 = DI G-2 57 = DI G-3 58 = DI G-4 59 = DI G-5 60 = DI G-6 61 = DI G-7 62 = DI G-8								
C4.2.3.7	Quick Stop	0 = Inactive 1 = DI X-1 2 = DI X-2 3 = DI X-3 4 = DI X-4 5 = DI X-5 6 = DI X-6 7 = DI A-1 8 = DI A-2 9 = DI A-3 10 = DI A-4 11 = DI A-5 12 = DI A-6 13 = DI A-7 14 = DI A-8 15 = DI B-1 16 = DI B-2 17 = DI B-3 18 = DI B-4 19 = DI B-5 20 = DI B-6 21 = DI B-7 22 = DI B-8 23 = DI C-1 24 = DI C-2 25 = DI C-3 26 = DI C-4 27 = DI C-5 28 = DI C-6 29 = DI C-7 30 = DI C-8 31 = DI D-1 32 = DI D-2		64h	3Dh	65h	USINT	6001	enum	1



Parameter	Description	Range of values	Decimal places	Class	Instance	Attribute	CIP data type	Net Id	Size	Qty mapped words	
		33 = DI D-3 34 = DI D-4 35 = DI D-5 36 = DI D-6 37 = DI D-7 38 = DI D-8 39 = DI E-1 40 = DI E-2 41 = DI E-3 42 = DI E-4 43 = DI E-5 44 = DI E-6 45 = DI E-7 46 = DI E-8 47 = DI F-1 48 = DI F-2 49 = DI F-3 50 = DI F-4 51 = DI F-5 52 = DI F-6 53 = DI F-7 54 = DI F-8 55 = DI G-1 56 = DI G-2 57 = DI G-3 58 = DI G-4 59 = DI G-5 60 = DI G-6 61 = DI G-7 62 = DI G-8									
C4.2.3.8	Direction of Rotation	0 = Inactive 1 = DI X-1 2 = DI X-2 3 = DI X-3 4 = DI X-4 5 = DI X-5 6 = DI X-6 7 = DI A-1 8 = DI A-2 9 = DI A-3 10 = DI A-4 11 = DI A-5 12 = DI A-6 13 = DI A-7 14 = DI A-8 15 = DI B-1 16 = DI B-2 17 = DI B-3 18 = DI B-4 19 = DI B-5		64h	3Dh	6Eh	USINT	6010	enum	1	



Parameter	Description	Range of values	Decimal places	Class	Instance	Attribute	CIP data type	Net Id	Size	Qty mapped words	
		20 = DI B-6 21 = DI B-7 22 = DI B-8 23 = DI C-1 24 = DI C-2 25 = DI C-3 26 = DI C-4 27 = DI C-5 28 = DI C-6 29 = DI C-7 30 = DI C-8 31 = DI D-1 32 = DI D-2 33 = DI D-3 34 = DI D-4 35 = DI D-5 36 = DI D-6 37 = DI D-7 38 = DI D-8 39 = DI E-1 40 = DI E-2 41 = DI E-3 42 = DI E-4 43 = DI E-5 44 = DI E-6 45 = DI E-7 46 = DI E-8 47 = DI F-1 48 = DI F-2 49 = DI F-3 50 = DI F-4 51 = DI F-5 52 = DI F-6 53 = DI F-7 54 = DI F-8 55 = DI G-1 56 = DI G-2 57 = DI G-3 58 = DI G-4 59 = DI G-5 60 = DI G-6 61 = DI G-7 62 = DI G-8									
C4.2.3.9	JOG	0 = Inactive 1 = DI X-1 2 = DI X-2 3 = DI X-3 4 = DI X-4 5 = DI X-5 6 = DI X-6		64h	3Dh	6Dh	USINT	6009	enum	1	



Parameter	Description	Range of values	Decimal places	Class	Instance	Attribute	CIP data type	Net Id	Size	Qty mapped words	
		7 = DI A-1 8 = DI A-2 9 = DI A-3 10 = DI A-4 11 = DI A-5 12 = DI A-6 13 = DI A-7 14 = DI A-8 15 = DI B-1 16 = DI B-2 17 = DI B-3 18 = DI B-4 19 = DI B-5 20 = DI B-6 21 = DI B-7 22 = DI B-8 23 = DI C-1 24 = DI C-2 25 = DI C-3 26 = DI C-4 27 = DI C-5 28 = DI C-6 29 = DI C-7 30 = DI C-8 31 = DI D-1 32 = DI D-2 33 = DI D-3 34 = DI D-4 35 = DI D-5 36 = DI D-6 37 = DI D-7 38 = DI D-8 39 = DI E-1 40 = DI E-2 41 = DI E-3 42 = DI E-4 43 = DI E-5 44 = DI E-6 45 = DI E-7 46 = DI E-8 47 = DI F-1 48 = DI F-2 49 = DI F-3 50 = DI F-4 51 = DI F-5 52 = DI F-6 53 = DI F-7 54 = DI F-8 55 = DI G-1 56 = DI G-2 57 = DI G-3									



Parameter	Description	Range of values	Decimal places	Class	Instance	Attribute	CIP data type	Net Id	Size	Qty mapped words
C4.2.3.10	Ramp Selection	58 = DI G-4 59 = DI G-5 60 = DI G-6 61 = DI G-7 62 = DI G-8 0 = Inactive 1 = DI X-1 2 = DI X-2 3 = DI X-3 4 = DI X-4 5 = DI X-5 6 = DI X-6 7 = DI A-1 8 = DI A-2 9 = DI A-3 10 = DI A-4 11 = DI A-5 12 = DI A-6 13 = DI A-7 14 = DI A-8 15 = DI B-1 16 = DI B-2 17 = DI B-3 18 = DI B-4 19 = DI B-5 20 = DI B-6 21 = DI B-7 22 = DI B-8 23 = DI C-1 24 = DI C-2 25 = DI C-3 26 = DI C-4 27 = DI C-5 28 = DI C-6 29 = DI C-7 30 = DI C-8 31 = DI D-1 32 = DI D-2 33 = DI D-3 34 = DI D-4 35 = DI D-5 36 = DI D-6 37 = DI D-7 38 = DI D-8 39 = DI E-1 40 = DI E-2 41 = DI E-3 42 = DI E-4 43 = DI E-5 44 = DI E-6		64h	3Dh	67h	USINT	6003	enum	1



Parameter	Description	Range of values	Decimal places	Class	Instance	Attribute	CIP data type	Net Id	Size	Qty mapped words
		45 = DI E-7 46 = DI E-8 47 = DI F-1 48 = DI F-2 49 = DI F-3 50 = DI F-4 51 = DI F-5 52 = DI F-6 53 = DI F-7 54 = DI F-8 55 = DI G-1 56 = DI G-2 57 = DI G-3 58 = DI G-4 59 = DI G-5 60 = DI G-6 61 = DI G-7 62 = DI G-8								
C4.2.3.11	Fault Reset	0 = Inactive 1 = DI X-1 2 = DI X-2 3 = DI X-3 4 = DI X-4 5 = DI X-5 6 = DI X-6 7 = DI A-1 8 = DI A-2 9 = DI A-3 10 = DI A-4 11 = DI A-5 12 = DI A-6 13 = DI A-7 14 = DI A-8 15 = DI B-1 16 = DI B-2 17 = DI B-3 18 = DI B-4 19 = DI B-5 20 = DI B-6 21 = DI B-7 22 = DI B-8 23 = DI C-1 24 = DI C-2 25 = DI C-3 26 = DI C-4 27 = DI C-5 28 = DI C-6 29 = DI C-7 30 = DI C-8 31 = DI D-1		64h	3Dh	66h	USINT	6002	enum	1



Parameter	Description	Range of values	Decimal places	Class	Instance	Attribute	CIP data type	Net Id	Size	Qty mapped words
		32 = DI D-2 33 = DI D-3 34 = DI D-4 35 = DI D-5 36 = DI D-6 37 = DI D-7 38 = DI D-8 39 = DI E-1 40 = DI E-2 41 = DI E-3 42 = DI E-4 43 = DI E-5 44 = DI E-6 45 = DI E-7 46 = DI E-8 47 = DI F-1 48 = DI F-2 49 = DI F-3 50 = DI F-4 51 = DI F-5 52 = DI F-6 53 = DI F-7 54 = DI F-8 55 = DI G-1 56 = DI G-2 57 = DI G-3 58 = DI G-4 59 = DI G-5 60 = DI G-6 61 = DI G-7 62 = DI G-8								
C4.2.4	HMI Config. for Commands									
C4.2.4.1	Stop Key Function	0 = Ramp to Stop 1 = General Enable to Stop 2 = Quick Stop		64h	03h	81h	USINT	229	enum	1
C4.3	References									
C4.3.1	Speed									
C4.3.1.1.1	Minimum Reference	0 to 60000 rpm	0	64h	02h	85h	UINT	133	16bit	1
C4.3.1.1.2	Maximum Reference	1 to 60000 rpm	0	64h	02h	86h	UINT	134	16bit	1
C4.3.1.2.1	Remote 1 Mode	0 = Keypad 1 = E.P. 2 = Multispeed 3 = Serial 4 = Not used 5 = CAN/CO/DN 6 = Ethernet 7 = Not used 8 = SoftPLC		64h	03h	79h	USINT	221	enum	1



Parameter	Description	Range of values	Decimal places	Class	Instance	Attribute	CIP data type	Net Id	Size	Qty mapped words
C4.3.1.2.2	Remote 2 Mode	9 = Analog Input (AI) 10 = Frequency Input (FI) 0 = Keypad 1 = E.P 2 = Multispeed 3 = Serial 4 = Not used 5 = CAN/CO/DN 6 = Ethernet 7 = Not used 8 = SoftPLC 9 = Analog Input (AI) 10 = Frequency Input (FI)		64h	03h	7Ah	USINT	222	enum	1
C4.3.1.3.1	Speed Ref. via HMI	0 to 60000 rpm	0	64h	02h	79h	UINT	121	16bit	1
C4.3.1.3.2	Speed Ref. AI Config.	0 = Inactive 1 = AI X-1 2 = AI X-2 3 = AI A-1 4 = AI A-2 5 = AI A-3 6 = Not used 7 = AI B-1 8 = AI B-2 9 = AI B-3 10 = Not used 11 = AI C-1 12 = AI C-2 13 = AI C-3 14 = Not used 15 = AI D-1 16 = AI D-2 17 = AI D-3 18 = Not used 19 = AI E-1 20 = AI E-2 21 = AI E-3 22 = Not used 23 = AI F-1 24 = AI F-2 25 = AI F-3 26 = Not used 27 = AI G-1 28 = AI G-2 29 = AI G-3 30 = Not used		64h	3Dh	75h	USINT	6017	enum	1
C4.3.1.3.3	Speed Ref. FI Config.	0 = Inactive 1 = FI X-5 2 = FI X-6		64h	3Dh	76h	USINT	6018	enum	1



Parameter	Description	Range of values	Decimal places	Class	Instance	Attribute	CIP data type	Net Id	Size	Qty mapped words
C4.3.1.4.1	DI Increase E.P.	0 = Inactive 1 = DI X-1 2 = DI X-2 3 = DI X-3 4 = DI X-4 5 = DI X-5 6 = DI X-6 7 = DI A-1 8 = DI A-2 9 = DI A-3 10 = DI A-4 11 = DI A-5 12 = DI A-6 13 = DI A-7 14 = DI A-8 15 = DI B-1 16 = DI B-2 17 = DI B-3 18 = DI B-4 19 = DI B-5 20 = DI B-6 21 = DI B-7 22 = DI B-8 23 = DI C-1 24 = DI C-2 25 = DI C-3 26 = DI C-4 27 = DI C-5 28 = DI C-6 29 = DI C-7 30 = DI C-8 31 = DI D-1 32 = DI D-2 33 = DI D-3 34 = DI D-4 35 = DI D-5 36 = DI D-6 37 = DI D-7 38 = DI D-8 39 = DI E-1 40 = DI E-2 41 = DI E-3 42 = DI E-4 43 = DI E-5 44 = DI E-6 45 = DI E-7 46 = DI E-8 47 = DI F-1 48 = DI F-2 49 = DI F-3		64h	3Dh	85h	USINT	6033	enum	1



Parameter	Description	Range of values	Decimal places	Class	Instance	Attribute	CIP data type	Net Id	Size	Qty mapped words
		50 = DI F-4 51 = DI F-5 52 = DI F-6 53 = DI F-7 54 = DI F-8 55 = DI G-1 56 = DI G-2 57 = DI G-3 58 = DI G-4 59 = DI G-5 60 = DI G-6 61 = DI G-7 62 = DI G-8								
C4.3.1.4.2	DI Decrease E.P.	0 = Inactive 1 = DI X-1 2 = DI X-2 3 = DI X-3 4 = DI X-4 5 = DI X-5 6 = DI X-6 7 = DI A-1 8 = DI A-2 9 = DI A-3 10 = DI A-4 11 = DI A-5 12 = DI A-6 13 = DI A-7 14 = DI A-8 15 = DI B-1 16 = DI B-2 17 = DI B-3 18 = DI B-4 19 = DI B-5 20 = DI B-6 21 = DI B-7 22 = DI B-8 23 = DI C-1 24 = DI C-2 25 = DI C-3 26 = DI C-4 27 = DI C-5 28 = DI C-6 29 = DI C-7 30 = DI C-8 31 = DI D-1 32 = DI D-2 33 = DI D-3 34 = DI D-4 35 = DI D-5 36 = DI D-6		64h	3Dh	86h	USINT	6034	enum	1



Parameter	Description	Range of values	Decimal places	Class	Instance	Attribute	CIP data type	Net Id	Size	Qty mapped words
		37 = DI D-7 38 = DI D-8 39 = DI E-1 40 = DI E-2 41 = DI E-3 42 = DI E-4 43 = DI E-5 44 = DI E-6 45 = DI E-7 46 = DI E-8 47 = DI F-1 48 = DI F-2 49 = DI F-3 50 = DI F-4 51 = DI F-5 52 = DI F-6 53 = DI F-7 54 = DI F-8 55 = DI G-1 56 = DI G-2 57 = DI G-3 58 = DI G-4 59 = DI G-5 60 = DI G-6 61 = DI G-7 62 = DI G-8								
C4.3.1.5.1	Multispeed Ref. 1	0 to 60000 rpm	0	64h	02h	7Ch	UINT	124	16bit	1
C4.3.1.5.2	Multispeed Ref. 2	0 to 60000 rpm	0	64h	02h	7Dh	UINT	125	16bit	1
C4.3.1.5.3	Multispeed Ref. 3	0 to 60000 rpm	0	64h	02h	7Eh	UINT	126	16bit	1
C4.3.1.5.4	Multispeed Ref. 4	0 to 60000 rpm	0	64h	02h	7Fh	UINT	127	16bit	1
C4.3.1.5.5	Multispeed Ref. 5	0 to 60000 rpm	0	64h	02h	80h	UINT	128	16bit	1
C4.3.1.5.6	Multispeed Ref. 6	0 to 60000 rpm	0	64h	02h	81h	UINT	129	16bit	1
C4.3.1.5.7	Multispeed Ref. 7	0 to 60000 rpm	0	64h	02h	82h	UINT	130	16bit	1
C4.3.1.5.8	Multispeed Ref. 8	0 to 60000 rpm	0	64h	02h	83h	UINT	131	16bit	1
C4.3.1.5.9	Multispeed 1 DI Config.	0 = Inactive 1 = DI X-1 2 = DI X-2 3 = DI X-3 4 = DI X-4 5 = DI X-5 6 = DI X-6 7 = DI A-1 8 = DI A-2 9 = DI A-3 10 = DI A-4 11 = DI A-5 12 = DI A-6 13 = DI A-7 14 = DI A-8 15 = DI B-1		64h	3Dh	82h	USINT	6030	enum	1



Parameter	Description	Range of values	Decimal places	Class	Instance	Attribute	CIP data type	Net Id	Size	Qty mapped words	
		16 = DI B-2 17 = DI B-3 18 = DI B-4 19 = DI B-5 20 = DI B-6 21 = DI B-7 22 = DI B-8 23 = DI C-1 24 = DI C-2 25 = DI C-3 26 = DI C-4 27 = DI C-5 28 = DI C-6 29 = DI C-7 30 = DI C-8 31 = DI D-1 32 = DI D-2 33 = DI D-3 34 = DI D-4 35 = DI D-5 36 = DI D-6 37 = DI D-7 38 = DI D-8 39 = DI E-1 40 = DI E-2 41 = DI E-3 42 = DI E-4 43 = DI E-5 44 = DI E-6 45 = DI E-7 46 = DI E-8 47 = DI F-1 48 = DI F-2 49 = DI F-3 50 = DI F-4 51 = DI F-5 52 = DI F-6 53 = DI F-7 54 = DI F-8 55 = DI G-1 56 = DI G-2 57 = DI G-3 58 = DI G-4 59 = DI G-5 60 = DI G-6 61 = DI G-7 62 = DI G-8									
C4.3.1.5.10	Multispeed 2 DI Config.	0 = Inactive 1 = DI X-1 2 = DI X-2		64h	3Dh	83h	USINT	6031	enum	1	



Parameter	Description	Range of values	Decimal places	Class	Instance	Attribute	CIP data type	Net Id	Size	Qty mapped words	
		3 = DI X-3 4 = DI X-4 5 = DI X-5 6 = DI X-6 7 = DI A-1 8 = DI A-2 9 = DI A-3 10 = DI A-4 11 = DI A-5 12 = DI A-6 13 = DI A-7 14 = DI A-8 15 = DI B-1 16 = DI B-2 17 = DI B-3 18 = DI B-4 19 = DI B-5 20 = DI B-6 21 = DI B-7 22 = DI B-8 23 = DI C-1 24 = DI C-2 25 = DI C-3 26 = DI C-4 27 = DI C-5 28 = DI C-6 29 = DI C-7 30 = DI C-8 31 = DI D-1 32 = DI D-2 33 = DI D-3 34 = DI D-4 35 = DI D-5 36 = DI D-6 37 = DI D-7 38 = DI D-8 39 = DI E-1 40 = DI E-2 41 = DI E-3 42 = DI E-4 43 = DI E-5 44 = DI E-6 45 = DI E-7 46 = DI E-8 47 = DI F-1 48 = DI F-2 49 = DI F-3 50 = DI F-4 51 = DI F-5 52 = DI F-6 53 = DI F-7									



Parameter	Description	Range of values	Decimal places	Class	Instance	Attribute	CIP data type	Net Id	Size	Qty mapped words
		54 = DI F-8 55 = DI G-1 56 = DI G-2 57 = DI G-3 58 = DI G-4 59 = DI G-5 60 = DI G-6 61 = DI G-7 62 = DI G-8								
C4.3.1.5.11	Multispeed 3 DI Config.	0 = Inactive 1 = DI X-1 2 = DI X-2 3 = DI X-3 4 = DI X-4 5 = DI X-5 6 = DI X-6 7 = DI A-1 8 = DI A-2 9 = DI A-3 10 = DI A-4 11 = DI A-5 12 = DI A-6 13 = DI A-7 14 = DI A-8 15 = DI B-1 16 = DI B-2 17 = DI B-3 18 = DI B-4 19 = DI B-5 20 = DI B-6 21 = DI B-7 22 = DI B-8 23 = DI C-1 24 = DI C-2 25 = DI C-3 26 = DI C-4 27 = DI C-5 28 = DI C-6 29 = DI C-7 30 = DI C-8 31 = DI D-1 32 = DI D-2 33 = DI D-3 34 = DI D-4 35 = DI D-5 36 = DI D-6 37 = DI D-7 38 = DI D-8 39 = DI E-1 40 = DI E-2		64h	3Dh	84h	USINT	6032	enum	1



Parameter	Description	Range of values	Decimal places	Class	Instance	Attribute	CIP data type	Net Id	Size	Qty mapped words
		41 = DI E-3 42 = DI E-4 43 = DI E-5 44 = DI E-6 45 = DI E-7 46 = DI E-8 47 = DI F-1 48 = DI F-2 49 = DI F-3 50 = DI F-4 51 = DI F-5 52 = DI F-6 53 = DI F-7 54 = DI F-8 55 = DI G-1 56 = DI G-2 57 = DI G-3 58 = DI G-4 59 = DI G-5 60 = DI G-6 61 = DI G-7 62 = DI G-8								
C4.3.1.6.1	Speed 1	0 to 60000 rpm	0	64h	04h	67h	UINT	303	16bit	1
C4.3.1.6.2	Speed 2	0 to 60000 rpm	0	64h	04h	68h	UINT	304	16bit	1
C4.3.1.6.3	Speed 3	0 to 60000 rpm	0	64h	04h	69h	UINT	305	16bit	1
C4.3.1.6.4	Skip Range	0 to 750 rpm	0	64h	04h	6Ah	UINT	306	16bit	1
C4.3.2	JOG Speed									
C4.3.2.1	JOG Reference	0 to 60000 rpm	0	64h	02h	76h	UINT	118	16bit	1
C4.3.3	Torque									
C4.3.3.1	Torque Reference via HMI	-400.0 to 400.0 %	1	64h	02h	77h	INT	119	s16bit	1
C4.3.3.2	Maximum Torque	0.0 to 400.0 %	1	64h	1Fh	AAh	UINT	3070	16bit	1
C4.3.3.3	Minimum Torque	0.0 to 400.0 %	1	64h	1Fh	ABh	UINT	3071	16bit	1
C4.3.3.4	Torque Ref. Source	0 = Keypad 1 = Analog Input (AI) 2 = Frequency Input (FI)		64h	63h	66h	USINT	9802	enum	1
C4.3.3.5	Torque Ref. AI Config.	0 = Inactive 1 = AI X-1 2 = AI X-2 3 = AI A-1 4 = AI A-2 5 = AI A-3 6 = Not used 7 = AI B-1 8 = AI B-2 9 = AI B-3 10 = Not used 11 = AI C-1 12 = AI C-2		64h	63h	65h	USINT	9801	enum	1



Parameter	Description	Range of values	Decimal places	Class	Instance	Attribute	CIP data type	Net Id	Size	Qty mapped words
		13 = AI C-3 14 = Not used 15 = AI D-1 16 = AI D-2 17 = AI D-3 18 = Not used 19 = AI E-1 20 = AI E-2 21 = AI E-3 22 = Not used 23 = AI F-1 24 = AI F-2 25 = AI F-3 26 = Not used 27 = AI G-1 28 = AI G-2 29 = AI G-3 30 = Not used								
C4.3.3.6	Torque Ref. FI Config.	0 = Inactive 1 = FI X-5 2 = FI X-6		64h	63h	64h	USINT	9800	enum	1
C5 Configuration\I/Os										
C5.1	Slot X									
C5.1.1	Slot X - Analog Inputs									
C5.1.1.1	AI1 Configurations	Bit 0 = Detect Disconnection Bit 2 = Signal Config.		64h	48h	7Eh	WORD	7126	2bit	1
C5.1.1.2	AI1 Filter	0.00 to 16.00 s	2	64h	48h	82h	UINT	7130	16bit	1
C5.1.1.3	AI1 Gain	0.000 to 9.999	3	64h	48h	86h	UINT	7134	16bit	1
C5.1.1.4	AI1 Offset	-100.00 to 100.00 %	2	64h	48h	8Ah	INT	7138	s16bit	1
C5.1.1.5	AI1 Dead Zone	0.00 to 100.00 %	2	64h	48h	8Eh	UINT	7142	16bit	1
C5.1.1.6	AI2 Configurations	Bit 0 = Detect Disconnection Bit 2 = Signal Config.		64h	48h	7Fh	WORD	7127	2bit	1
C5.1.1.7	AI2 Filter	0.00 to 16.00 s	2	64h	48h	83h	UINT	7131	16bit	1
C5.1.1.8	AI2 Gain	0.000 to 9.999	3	64h	48h	87h	UINT	7135	16bit	1
C5.1.1.9	AI2 Offset	-100.00 to 100.00 %	2	64h	48h	8Bh	INT	7139	s16bit	1
C5.1.1.10	AI2 Dead Zone	0.00 to 100.00 %	2	64h	48h	8Fh	UINT	7143	16bit	1
C5.1.2	Slot X - Analog Outputs									
C5.1.2.1	AO1 Signal Type	0 = 0 to 20 mA 1 = 4 to 20 mA 2 = 20 to 0 mA 3 = 20 to 4 mA 4 = 0 to 10 V 5 = 10 to 0 V		64h	48h	B3h	USINT	7179	enum	1
C5.1.2.2	AO1 Gain	0.000 to 9.999	3	64h	48h	B7h	UINT	7183	16bit	1
C5.1.2.3	AO1 Function			64h	48h	BBh	USINT	7187	enum	1



Parameter	Description	Range of values	Decimal places	Class	Instance	Attribute	CIP data type	Net Id	Size	Qty mapped words
		0 = Off (0 %) 1 = On (100%) 2 = Speed Ref. 3 = Total Speed Ref. 4 = Real Speed 5 ... 6 = Not used 7 = Output Current 8 ... 9 = Not used 10 = Output Power 11 ... 12 = Not used 13 = Motor Torque 14 = SoftPLC 15 = PTC 16 = Motor lxt 17 = Encoder Speed 18 = Network 19 = Not used 20 = Torque Ref. 21 = Total Torque Ref.								
C5.1.2.4	AO1 Offset	-100.00 to 100.00 %	2	64h	48h	BFh	INT	7191	s16bit	1
C5.1.2.5	AO2 Signal Type			64h	48h	B4h	USINT	7180	enum	1
		0 = 0 to 20 mA 1 = 4 to 20 mA 2 = 20 to 0 mA 3 = 20 to 4 mA 4 = 0 to 10 V 5 = 10 to 0 V								
C5.1.2.6	AO2 Gain	0.000 to 9.999	3	64h	48h	B8h	UINT	7184	16bit	1
C5.1.2.7	AO2 Function			64h	48h	BCh	USINT	7188	enum	1
		0 = Off (0 %) 1 = On (100%) 2 = Speed Ref. 3 = Total Speed Ref. 4 = Real Speed 5 ... 6 = Not used 7 = Output Current 8 ... 9 = Not used 10 = Output Power 11 ... 12 = Not used 13 = Motor Torque 14 = SoftPLC 15 = PTC 16 = Motor lxt 17 = Encoder Speed 18 = Network 19 = Not used 20 = Torque Ref. 21 = Total Torque Ref.								
C5.1.2.8	AO2 Offset	-100.00 to 100.00 %	2	64h	48h	C0h	INT	7192	s16bit	1
C5.1.3	Slot X - Digital Inputs									



Parameter	Description	Range of values	Decimal places	Class	Instance	Attribute	CIP data type	Net Id	Size	Qty mapped words
C5.1.3.4	DI5 Operation Mode	0 = Polling 1 = Not used 2 = Frequency 3 = Encoder		64h	49h	BDh	USINT	7289	enum	1
C5.1.3.5	FI5 Min Frequency	0 to 32000 Hz	0	64h	49h	ADh	UINT	7273	16bit	1
C5.1.3.6	FI5 Maximum Frequency	0 to 32000 Hz	0	64h	49h	ABh	UINT	7271	16bit	1
C5.1.3.7	FI5 Gain	0.000 to 9.999	3	64h	49h	A9h	UINT	7269	16bit	1
C5.1.3.8	FI5 Offset	-100.00 to 100.00 %	2	64h	49h	A7h	INT	7267	s16bit	1
C5.1.3.9	DI6 Operation Mode	0 = Polling 1 = Not used 2 = Frequency 3 = Encoder		64h	49h	BEh	USINT	7290	enum	1
C5.1.3.10	FI6 Minimum Frequency	0 to 32000 Hz	0	64h	49h	A Eh	UINT	7274	16bit	1
C5.1.3.11	FI6 Maximum Frequency	0 to 32000 Hz	0	64h	49h	AC h	UINT	7272	16bit	1
C5.1.3.12	FI6 Gain	0.000 to 9.999	3	64h	49h	AA h	UINT	7270	16bit	1
C5.1.3.13	FI6 Offset	-100.00 to 100.00 %	2	64h	49h	A8 h	INT	7268	s16bit	1
C5.1.4	Slot X - Digital Outputs									
C5.1.4.1	DO1 Operation Mode	0 = Polling 1 = Frequency		64h	49h	C1h	USINT	7293	enum	1
C5.1.4.2	DO1 Function	0 = Off 1 = On 2 = N* > Nx 3 = N > Nx 4 = N < Ny 5 = N = N* 6 ... 7 = Not used 8 = F > Fx 9 = Is > lx 10 = Is < lx 11 = Torque > Tx 12 = Torque < Tx 13 = Hours Enabled > Hx 14 ... 15 = Not used 16 = Local Mode 17 = Remote 1 Mode 18 = Remote 2 Mode 19 = Run 20 = Ready 21 = STO 22 = No Fault 23 = With Fault 24 = No Alarm 25 = No Fault and Alarm 26 = Network 27 = SoftPLC 28 = Forward Direction		64h	48h	9Bh	USINT	7155	enum	1



Parameter	Description	Range of values	Decimal places	Class	Instance	Attribute	CIP data type	Net Id	Size	Qty mapped words
C5.1.4.3	FO1 Function	29 = Ride-Through 30 = Pre-Charge OK 0 = Off (0 %) 1 = On (100%) 2 = Speed Ref. 3 = Total Speed Ref. 4 = Real Speed 5 ... 6 = Not used 7 = Output Current 8 ... 9 = Not used 10 = Output Power 11 ... 12 = Not used 13 = Motor Torque 14 = SoftPLC 15 = Not used 16 = Motor lxt 17 = Encoder Speed 18 = Network 19 = Not used 20 = Torque Ref. 21 = Total Torque Ref.		64h	49h	AFh	USINT	7275	enum	1
C5.1.4.4	FO1 Minimum Frequency	0 to 32000 Hz	0	64h	49h	B7h	UINT	7283	16bit	1
C5.1.4.5	FO1 Maximum Frequency	0 to 32000 Hz	0	64h	49h	B5h	UINT	7281	16bit	1
C5.1.4.6	FO1 Gain	0.000 to 9.999	3	64h	49h	B3h	UINT	7279	16bit	1
C5.1.4.7	FO1 Offset	-100.00 to 100.00 %	2	64h	49h	B1h	INT	7277	s16bit	1
C5.1.4.10	DO2 Operation Mode	0 = Polling 1 = Frequency		64h	49h	C2h	USINT	7294	enum	1
C5.1.4.11	DO2 Function	0 = Off 1 = On 2 = N* > Nx 3 = N > Nx 4 = N < Ny 5 = N = N* 6 ... 7 = Not used 8 = F > Fx 9 = ls > lx 10 = ls < lx 11 = Torque > Tx 12 = Torque < Tx 13 = Hours Enabled > Hx 14 ... 15 = Not used 16 = Local Mode 17 = Remote 1 Mode 18 = Remote 2 Mode 19 = Run 20 = Ready 21 = STO 22 = No Fault		64h	48h	9Ch	USINT	7156	enum	1



Parameter	Description	Range of values	Decimal places	Class	Instance	Attribute	CIP data type	Net Id	Size	Qty mapped words
		23 = With Fault 24 = No Alarm 25 = No Fault and Alarm 26 = Network 27 = SoftPLC 28 = Forward Direction 29 = Ride-Through 30 = Pre-Charge OK								
C5.1.4.12	FO2 Function	0 = Off (0 %) 1 = On (100%) 2 = Speed Ref. 3 = Total Speed Ref. 4 = Real Speed 5 ... 6 = Not used 7 = Output Current 8 ... 9 = Not used 10 = Output Power 11 ... 12 = Not used 13 = Motor Torque 14 = SoftPLC 15 = Not used 16 = Motor lxt 17 = Encoder Speed 18 = Network 19 = Not used 20 = Torque Ref. 21 = Total Torque Ref.		64h	49h	B0h	USINT	7276	enum	1
C5.1.4.13	FO2 Minimum Frequency	0 to 32000 Hz	0	64h	49h	B8h	UINT	7284	16bit	1
C5.1.4.14	FO2 Maximum Frequency	0 to 32000 Hz	0	64h	49h	B6h	UINT	7282	16bit	1
C5.1.4.15	FO2 Gain	0.000 to 9.999	3	64h	49h	B4h	UINT	7280	16bit	1
C5.1.4.16	FO2 Offset	-100.00 to 100.00 %	2	64h	49h	B2h	INT	7278	s16bit	1
C5.1.5	Slot X-Encoder									
C5.1.5.1	Number of Pulses	1 to 65535 ppr	0	64h	48h	7Bh	UINT	7123	16bit	1
C5.2	Slot A									
C5.2.1	Slot A-Analog Inputs									
C5.2.1.1	A11 Settings	Bit 0 = Detect Disconnection Bit 2 = Signal Setting		64h	4Bh	7Eh	WORD	7426	2bit	1
C5.2.1.2	A11 Filter	0.00 to 16.00 s	2	64h	4Bh	82h	UINT	7430	16bit	1
C5.2.1.3	A11 Gain	0.000 to 9.999	3	64h	4Bh	86h	UINT	7434	16bit	1
C5.2.1.4	A11 Offset	-100.00 to 100.00 %	2	64h	4Bh	8Ah	INT	7438	s16bit	1
C5.2.1.5	A11 Dead Zone	0.00 to 100.00 %	2	64h	4Bh	8Eh	UINT	7442	16bit	1
C5.2.1.6	A12 Settings	Bit 0 = Detect Disconnection Bit 2 = Signal Setting		64h	4Bh	7Fh	WORD	7427	2bit	1
C5.2.1.7	A12 Filter	0.00 to 16.00 s	2	64h	4Bh	83h	UINT	7431	16bit	1
C5.2.1.8	A12 Gain	0.000 to 9.999	3	64h	4Bh	87h	UINT	7435	16bit	1
C5.2.1.9	A12 Offset	-100.00 to 100.00 %	2	64h	4Bh	8Bh	INT	7439	s16bit	1
C5.2.1.10	A12 Dead Zone	0.00 to 100.00 %	2	64h	4Bh	8Fh	UINT	7443	16bit	1



Parameter	Description	Range of values	Decimal places	Class	Instance	Attribute	CIP data type	Net Id	Size	Qty mapped words
C5.2.1.11	AI3 Settings	Bit 0 = Detect Disconnection Bit 2 = Signal Setting		64h	4Bh	80h	WORD	7428	2bit	1
C5.2.1.12	AI3 Filter	0.00 to 16.00 s	2	64h	4Bh	84h	UINT	7432	16bit	1
C5.2.1.13	AI3 Gain	0.000 to 9.999	3	64h	4Bh	88h	UINT	7436	16bit	1
C5.2.1.14	AI3 Offset	-100.00 to 100.00 %	2	64h	4Bh	8Ch	INT	7440	s16bit	1
C5.2.1.15	AI3 Dead Zone	0.00 to 100.00 %	2	64h	4Bh	90h	UINT	7444	16bit	1
C5.2.2	Slot A - Analog Outputs									
C5.2.2.1	AO1 Signal Type	0 = 0 to 20 mA 1 = 4 to 20 mA 2 = 20 to 0 mA 3 = 20 to 4 mA 4 = 0 to 10 V 5 = 10 to 0 V 6 ... 7 = Not used		64h	4Bh	B3h	USINT	7479	enum	1
C5.2.2.2	AO1 Gain	0.000 to 9.999	3	64h	4Bh	B7h	UINT	7483	16bit	1
C5.2.2.3	AO1 Function	0 = Off (0 %) 1 = On (100%) 2 = Speed Ref. 3 = Total Speed Ref. 4 = Real Speed 5 ... 6 = Not used 7 = Output Current 8 ... 9 = Not used 10 = Output Power 11 ... 12 = Not used 13 = Motor Torque 14 = SoftPLC 15 = PTC 16 = Motor Ixt 17 = Encoder Speed 18 = Network 19 = Not used 20 = Torque Ref. 21 = Total Torque Ref.		64h	4Bh	BBh	USINT	7487	enum	1
C5.2.2.4	AO1 Offset	-100.00 to 100.00 %	2	64h	4Bh	BFh	INT	7491	s16bit	1
C5.2.2.5	AO2 Signal Type	0 = 0 to 20 mA 1 = 4 to 20 mA 2 = 20 to 0 mA 3 = 20 to 4 mA 4 = 0 to 10 V 5 = 10 to 0 V 6 ... 7 = Not used		64h	4Bh	B4h	USINT	7480	enum	1
C5.2.2.6	AO2 Gain	0.000 to 9.999	3	64h	4Bh	B8h	UINT	7484	16bit	1
C5.2.2.7	AO2 Function	0 = Off (0 %) 1 = On (100%)		64h	4Bh	BCh	USINT	7488	enum	1



Parameter	Description	Range of values	Decimal places	Class	Instance	Attribute	CIP data type	Net Id	Size	Qty mapped words
		2 = Speed Ref. 3 = Total Speed Ref. 4 = Real Speed 5 ... 6 = Not used 7 = Output Current 8 ... 9 = Not used 10 = Output Power 11 ... 12 = Not used 13 = Motor Torque 14 = SoftPLC 15 = PTC 16 = Motor lxt 17 = Encoder Speed 18 = Network 19 = Not used 20 = Torque Ref. 21 = Total Torque Ref.								
C5.2.2.8	AO2 Offset	-100.00 to 100.00 %	2	64h	4Bh	C0h	INT	7492	s16bit	1
C5.2.4	Slot A - Digital Outputs									
C5.2.4.1	DO1 Function	0 = Off 1 = On 2 = N* > Nx 3 = N > Nx 4 = N < Ny 5 = N = N* 6 ... 7 = Not used 8 = F > Fx 9 = Is > lx 10 = Is < lx 11 = Torque > Tx 12 = Torque < Tx 13 = Hours Enabled > Hx 14 ... 15 = Not used 16 = Local Mode 17 = Remote 1 Mode 18 = Remote 2 Mode 19 = Run 20 = Ready 21 = STO 22 = No Fault 23 = With Fault 24 = No Alarm 25 = No Fault and Alarm 26 = Network 27 = SoftPLC 28 = Forward Direction 29 = Ride-Through 30 = Pre-Charge OK		64h	4Bh	9Bh	USINT	7455	enum	1
C5.2.4.4	DO2 Function	0 = Off		64h	4Bh	9Ch	USINT	7456	enum	1



Parameter	Description	Range of values	Decimal places	Class	Instance	Attribute	CIP data type	Net Id	Size	Qty mapped words
		1 = On 2 = N* > Nx 3 = N > Nx 4 = N < Ny 5 = N = N* 6 ... 7 = Not used 8 = F > Fx 9 = Is > lx 10 = Is < lx 11 = Torque > Tx 12 = Torque < Tx 13 = Hours Enabled > Hx 14 ... 15 = Not used 16 = Local Mode 17 = Remote 1 Mode 18 = Remote 2 Mode 19 = Run 20 = Ready 21 = STO 22 = No Fault 23 = With Fault 24 = No Alarm 25 = No Fault and Alarm 26 = Network 27 = SoftPLC 28 = Forward Direction 29 = Ride-Through 30 = Pre-Charge OK								
C5.2.4.7	DO3 Function	0 = Off 1 = On 2 = N* > Nx 3 = N > Nx 4 = N < Ny 5 = N = N* 6 ... 7 = Not used 8 = F > Fx 9 = Is > lx 10 = Is < lx 11 = Torque > Tx 12 = Torque < Tx 13 = Hours Enabled > Hx 14 ... 15 = Not used 16 = Local Mode 17 = Remote 1 Mode 18 = Remote 2 Mode 19 = Run 20 = Ready 21 = STO 22 = No Fault 23 = With Fault		64h	4Bh	9Dh	USINT	7457	enum	1



Parameter	Description	Range of values	Decimal places	Class	Instance	Attribute	CIP data type	Net Id	Size	Qty mapped words
C5.2.4.10	DO4 Function	24 = No Alarm 25 = No Fault and Alarm 26 = Network 27 = SoftPLC 28 = Forward Direction 29 = Ride-Through 30 = Pre-Charge OK		64h	4Bh	9Eh	USINT	7458	enum	1
C5.2.4.13	DO5 Function	0 = Off 1 = On 2 = N* > Nx 3 = N > Nx 4 = N < Ny 5 = N = N* 6 ... 7 = Not used 8 = F > Fx 9 = Is > Ix 10 = Is < Ix 11 = Torque > Tx 12 = Torque < Tx 13 = Hours Enabled > Hx 14 ... 15 = Not used 16 = Local Mode 17 = Remote 1 Mode 18 = Remote 2 Mode 19 = Run 20 = Ready 21 = STO 22 = No Fault 23 = With Fault 24 = No Alarm 25 = No Fault and Alarm 26 = Network 27 = SoftPLC 28 = Forward Direction 29 = Ride-Through 30 = Pre-Charge OK		64h	4Bh	9Fh	USINT	7459	enum	1



Parameter	Description	Range of values	Decimal places	Class	Instance	Attribute	CIP data type	Net Id	Size	Qty mapped words
		14 ... 15 = Not used 16 = Local Mode 17 = Remote 1 Mode 18 = Remote 2 Mode 19 = Run 20 = Ready 21 = STO 22 = No Fault 23 = With Fault 24 = No Alarm 25 = No Fault and Alarm 26 = Network 27 = SoftPLC 28 = Forward Direction 29 = Ride-Through 30 = Pre-Charge OK								
C5.2.4.16	DO6 Function	0 = Off 1 = On 2 = N* > Nx 3 = N > Nx 4 = N < Ny 5 = N = N* 6 ... 7 = Not used 8 = F > Fx 9 = Is > Ix 10 = Is < Ix 11 = Torque > Tx 12 = Torque < Tx 13 = Hours Enabled > Hx 14 ... 15 = Not used 16 = Local Mode 17 = Remote 1 Mode 18 = Remote 2 Mode 19 = Run 20 = Ready 21 = STO 22 = No Fault 23 = With Fault 24 = No Alarm 25 = No Fault and Alarm 26 = Network 27 = SoftPLC 28 = Forward Direction 29 = Ride-Through 30 = Pre-Charge OK		64h	4Bh	A0h	USINT	7460	enum	1
C5.2.4.19	DO7 Function	0 = Off 1 = On 2 = N* > Nx 3 = N > Nx		64h	4Bh	A1h	USINT	7461	enum	1



Parameter	Description	Range of values	Decimal places	Class	Instance	Attribute	CIP data type	Net Id	Size	Qty mapped words
		4 = N < Ny 5 = N = N* 6 ... 7 = Not used 8 = F > Fx 9 = Is > Ix 10 = Is < Ix 11 = Torque > Tx 12 = Torque < Tx 13 = Hours Enabled > Hx 14 ... 15 = Not used 16 = Local Mode 17 = Remote 1 Mode 18 = Remote 2 Mode 19 = Run 20 = Ready 21 = STO 22 = No Fault 23 = With Fault 24 = No Alarm 25 = No Fault and Alarm 26 = Network 27 = SoftPLC 28 = Forward Direction 29 = Ride-Through 30 = Pre-Charge OK								
C5.2.4.22	DO8 Function	0 = Off 1 = On 2 = N* > Nx 3 = N > Nx 4 = N < Ny 5 = N = N* 6 ... 7 = Not used 8 = F > Fx 9 = Is > Ix 10 = Is < Ix 11 = Torque > Tx 12 = Torque < Tx 13 = Hours Enabled > Hx 14 ... 15 = Not used 16 = Local Mode 17 = Remote 1 Mode 18 = Remote 2 Mode 19 = Run 20 = Ready 21 = STO 22 = No Fault 23 = With Fault 24 = No Alarm 25 = No Fault and Alarm 26 = Network		64h	4Bh	A2h	USINT	7462	enum	1



Parameter	Description	Range of values	Decimal places	Class	Instance	Attribute	CIP data type	Net Id	Size	Qty mapped words
		27 = SoftPLC 28 = Forward Direction 29 = Ride-Through 30 = Pre-Charge OK								
C5.2.5	Slot A-Encoder									
C5.2.5.1	Number of Pulses	1 to 65535 ppr	0	64h	4Bh	7Bh	UINT	7423	16bit	1
C5.2.5.2	Settings	Bit 0 = Broken Cable A Bit 2 = Broken Cable B Bit 4 = Broken Cable Z Bit 6 = Search Zero Bit 7 = Signal Direction		64h	4Bh	7Ch	WORD	7424	5bit	1
C5.2.6	Slot A-Temperatures									
C5.2.6.1	Sensor Type	0 = PT100 1 = PT1000 2 = Single PTC 3 = Triple PTC		64h	4Bh	92h	USINT	7446	enum	1
C5.2.6.2	Overtemperature Config.	Bit 0 = S1 Sensor F/A Bit 2 = S2 Sensor F/A Bit 4 = S3 Sensor F/A Bit 6 = S4 Sensor F/A Bit 8 = S5 Sensor F/A Bit 10 = S6 Sensor F/A		64h	4Bh	93h	WORD	7447	6bit	1
C5.2.6.3	Measurement Error Config.	Bit 0 = S1 Sensor F/A Bit 2 = S2 Sensor F/A Bit 4 = S3 Sensor F/A Bit 6 = S4 Sensor F/A Bit 8 = S5 Sensor F/A Bit 10 = S6 Sensor F/A		64h	4Bh	94h	WORD	7448	6bit	1
C5.2.6.4	Temp. 1 Sensor Setpoint	-100.0 to 250.0 °C	1	64h	4Bh	95h	INT	7449	s16bit	1
C5.2.6.5	Temp. 2 Sensor Setpoint	-100.0 to 250.0 °C	1	64h	4Bh	96h	INT	7450	s16bit	1
C5.2.6.6	Temp. 3 Sensor Setpoint	-100.0 to 250.0 °C	1	64h	4Bh	97h	INT	7451	s16bit	1
C5.2.6.7	Temp. 4 Sensor Setpoint	-100.0 to 250.0 °C	1	64h	4Bh	98h	INT	7452	s16bit	1
C5.2.6.8	Temp. 5 Sensor Setpoint	-100.0 to 250.0 °C	1	64h	4Bh	99h	INT	7453	s16bit	1
C5.2.6.9	Temp. 6 Sensor Setpoint	-100.0 to 250.0 °C	1	64h	4Bh	9Ah	INT	7454	s16bit	1
C5.3	Slot B									
C5.3.1	Slot B-Analog Inputs									
C5.3.1.1	A11 Settings	Bit 0 = Detect Disconnection Bit 2 = Signal Setting		64h	4Eh	7Eh	WORD	7726	2bit	1
C5.3.1.2	A11 Filter	0.00 to 16.00 s		64h	4Eh	82h	UINT	7730	16bit	1
C5.3.1.3	A11 Gain	0.000 to 9.999	3	64h	4Eh	86h	UINT	7734	16bit	1
C5.3.1.4	A11 Offset	-100.00 to 100.00 %	2	64h	4Eh	8Ah	INT	7738	s16bit	1
C5.3.1.5	A11 Dead Zone	0.00 to 100.00 %	2	64h	4Eh	8Eh	UINT	7742	16bit	1
C5.3.1.6	A12 Settings	Bit 0 = Detect Disconnection		64h	4Eh	7Fh	WORD	7727	2bit	1



Parameter	Description	Range of values	Decimal places	Class	Instance	Attribute	CIP data type	Net Id	Size	Qty mapped words
C5.3.1.7	AI2 Filter	Bit 2 = Signal Setting 0.00 to 16.00 s	2	64h	4Eh	83h	UINT	7731	16bit	1
C5.3.1.8	AI2 Gain	0.000 to 9.999	3	64h	4Eh	87h	UINT	7735	16bit	1
C5.3.1.9	AI2 Offset	-100.00 to 100.00 %	2	64h	4Eh	8Bh	INT	7739	s16bit	1
C5.3.1.10	AI2 Dead Zone	0.00 to 100.00 %	2	64h	4Eh	8Fh	UINT	7743	16bit	1
C5.3.1.11	AI3 Settings			64h	4Eh	80h	WORD	7728	2bit	1
		Bit 0 = Detect Disconnection Bit 2 = Signal Setting								
C5.3.1.12	AI3 Filter	0.00 to 16.00 s	2	64h	4Eh	84h	UINT	7732	16bit	1
C5.3.1.13	AI3 Gain	0.000 to 9.999	3	64h	4Eh	88h	UINT	7736	16bit	1
C5.3.1.14	AI3 Offset	-100.00 to 100.00 %	2	64h	4Eh	8Ch	INT	7740	s16bit	1
C5.3.1.15	AI3 Dead Zone	0.00 to 100.00 %	2	64h	4Eh	90h	UINT	7744	16bit	1
C5.3.2	Slot B-Analog Outputs									
C5.3.2.1	AO1 Signal Type	0 = 0 to 20 mA 1 = 4 to 20 mA 2 = 20 to 0 mA 3 = 20 to 4 mA 4 = 0 to 10 V 5 = 10 to 0 V 6 ... 7 = Not used		64h	4Eh	B3h	USINT	7779	enum	1
C5.3.2.2	AO1 Gain	0.000 to 9.999	3	64h	4Eh	B7h	UINT	7783	16bit	1
C5.3.2.3	AO1 Function	0 = Off (0 %) 1 = On (100%) 2 = Speed Ref. 3 = Total Speed Ref. 4 = Real Speed 5 ... 6 = Not used 7 = Output Current 8 ... 9 = Not used 10 = Output Power 11 ... 12 = Not used 13 = Motor Torque 14 = SoftPLC 15 = PTC 16 = Motor lxt 17 = Encoder Speed 18 = Network 19 = Not used 20 = Torque Ref. 21 = Total Torque Ref.		64h	4Eh	BBh	USINT	7787	enum	1
C5.3.2.4	AO1 Offset	-100.00 to 100.00 %	2	64h	4Eh	BFh	INT	7791	s16bit	1
C5.3.2.5	AO2 Signal Type	0 = 0 to 20 mA 1 = 4 to 20 mA 2 = 20 to 0 mA 3 = 20 to 4 mA 4 = 0 to 10 V 5 = 10 to 0 V		64h	4Eh	B4h	USINT	7780	enum	1



Parameter	Description	Range of values	Decimal places	Class	Instance	Attribute	CIP data type	Net Id	Size	Qty mapped words
C5.3.2.6	AO2 Gain	6 ... 7 = Not used 0.000 to 9.999	3	64h	4Eh	B8h	UINT	7784	16bit	1
C5.3.2.7	AO2 Function	0 = Off (0 %) 1 = On (100%) 2 = Speed Ref. 3 = Total Speed Ref. 4 = Real Speed 5 ... 6 = Not used 7 = Output Current 8 ... 9 = Not used 10 = Output Power 11 ... 12 = Not used 13 = Motor Torque 14 = SoftPLC 15 = PTC 16 = Motor lxt 17 = Encoder Speed 18 = Network 19 = Not used 20 = Torque Ref. 21 = Total Torque Ref.		64h	4Eh	BCh	USINT	7788	enum	1
C5.3.2.8	AO2 Offset	-100.00 to 100.00 %	2	64h	4Eh	C0h	INT	7792	s16bit	1
C5.3.4	Slot B-Digital Outputs									
C5.3.4.1	DO1 Function	0 = Off 1 = On 2 = N* > Nx 3 = N > Nx 4 = N < Ny 5 = N = N* 6 ... 7 = Not used 8 = F > Fx 9 = Is > lx 10 = Is < lx 11 = Torque > Tx 12 = Torque < Tx 13 = Hours Enabled > Hx 14 ... 15 = Not used 16 = Local Mode 17 = Remote 1 Mode 18 = Remote 2 Mode 19 = Run 20 = Ready 21 = STO 22 = No Fault 23 = With Fault 24 = No Alarm 25 = No Fault and Alarm 26 = Network 27 = SoftPLC		64h	4Eh	9Bh	USINT	7755	enum	1



Parameter	Description	Range of values	Decimal places	Class	Instance	Attribute	CIP data type	Net Id	Size	Qty mapped words
C5.3.4.4	DO2 Function	28 = Forward Direction 29 = Ride-Through 30 = Pre-Charge OK 0 = Off 1 = On 2 = N* > Nx 3 = N > Nx 4 = N < Ny 5 = N = N* 6 ... 7 = Not used 8 = F > Fx 9 = Is > Ix 10 = Is < Ix 11 = Torque > Tx 12 = Torque < Tx 13 = Hours Enabled > Hx 14 ... 15 = Not used 16 = Local Mode 17 = Remote 1 Mode 18 = Remote 2 Mode 19 = Run 20 = Ready 21 = STO 22 = No Fault 23 = With Fault 24 = No Alarm 25 = No Fault and Alarm 26 = Network 27 = SoftPLC 28 = Forward Direction 29 = Ride-Through 30 = Pre-Charge OK		64h	4Eh	9Ch	USINT	7756	enum	1
C5.3.4.7	DO3 Function	0 = Off 1 = On 2 = N* > Nx 3 = N > Nx 4 = N < Ny 5 = N = N* 6 ... 7 = Not used 8 = F > Fx 9 = Is > Ix 10 = Is < Ix 11 = Torque > Tx 12 = Torque < Tx 13 = Hours Enabled > Hx 14 ... 15 = Not used 16 = Local Mode 17 = Remote 1 Mode 18 = Remote 2 Mode		64h	4Eh	9Dh	USINT	7757	enum	1



Parameter	Description	Range of values	Decimal places	Class	Instance	Attribute	CIP data type	Net Id	Size	Qty mapped words
		19 = Run 20 = Ready 21 = STO 22 = No Fault 23 = With Fault 24 = No Alarm 25 = No Fault and Alarm 26 = Network 27 = SoftPLC 28 = Forward Direction 29 = Ride-Through 30 = Pre-Charge OK								
C5.3.4.10	DO4 Function	0 = Off 1 = On 2 = N* > Nx 3 = N > Nx 4 = N < Ny 5 = N = N* 6 ... 7 = Not used 8 = F > Fx 9 = Is > Ix 10 = Is < Ix 11 = Torque > Tx 12 = Torque < Tx 13 = Hours Enabled > Hx 14 ... 15 = Not used 16 = Local Mode 17 = Remote 1 Mode 18 = Remote 2 Mode 19 = Run 20 = Ready 21 = STO 22 = No Fault 23 = With Fault 24 = No Alarm 25 = No Fault and Alarm 26 = Network 27 = SoftPLC 28 = Forward Direction 29 = Ride-Through 30 = Pre-Charge OK		64h	4Eh	9Eh	USINT	7758	enum	1
C5.3.4.13	DO5 Function	0 = Off 1 = On 2 = N* > Nx 3 = N > Nx 4 = N < Ny 5 = N = N* 6 ... 7 = Not used 8 = F > Fx		64h	4Eh	9Fh	USINT	7759	enum	1



Parameter	Description	Range of values	Decimal places	Class	Instance	Attribute	CIP data type	Net Id	Size	Qty mapped words
		9 = Is > Ix 10 = Is < Ix 11 = Torque > Tx 12 = Torque < Tx 13 = Hours Enabled > Hx 14 ... 15 = Not used 16 = Local Mode 17 = Remote 1 Mode 18 = Remote 2 Mode 19 = Run 20 = Ready 21 = STO 22 = No Fault 23 = With Fault 24 = No Alarm 25 = No Fault and Alarm 26 = Network 27 = SoftPLC 28 = Forward Direction 29 = Ride-Through 30 = Pre-Charge OK								
C5.3.4.16	DO6 Function	0 = Off 1 = On 2 = N* > Nx 3 = N > Nx 4 = N < Ny 5 = N = N* 6 ... 7 = Not used 8 = F > Fx 9 = Is > Ix 10 = Is < Ix 11 = Torque > Tx 12 = Torque < Tx 13 = Hours Enabled > Hx 14 ... 15 = Not used 16 = Local Mode 17 = Remote 1 Mode 18 = Remote 2 Mode 19 = Run 20 = Ready 21 = STO 22 = No Fault 23 = With Fault 24 = No Alarm 25 = No Fault and Alarm 26 = Network 27 = SoftPLC 28 = Forward Direction 29 = Ride-Through 30 = Pre-Charge OK		64h	4Eh	A0h	USINT	7760	enum	1



Parameter	Description	Range of values	Decimal places	Class	Instance	Attribute	CIP data type	Net Id	Size	Qty mapped words
C5.3.4.19	DO7 Function	0 = Off 1 = On 2 = N* > Nx 3 = N > Nx 4 = N < Ny 5 = N = N* 6 ... 7 = Not used 8 = F > Fx 9 = Is > Ix 10 = Is < Ix 11 = Torque > Tx 12 = Torque < Tx 13 = Hours Enabled > Hx 14 ... 15 = Not used 16 = Local Mode 17 = Remote 1 Mode 18 = Remote 2 Mode 19 = Run 20 = Ready 21 = STO 22 = No Fault 23 = With Fault 24 = No Alarm 25 = No Fault and Alarm 26 = Network 27 = SoftPLC 28 = Forward Direction 29 = Ride-Through 30 = Pre-Charge OK		64h	4Eh	A1h	USINT	7761	enum	1
C5.3.4.22	DO8 Function	0 = Off 1 = On 2 = N* > Nx 3 = N > Nx 4 = N < Ny 5 = N = N* 6 ... 7 = Not used 8 = F > Fx 9 = Is > Ix 10 = Is < Ix 11 = Torque > Tx 12 = Torque < Tx 13 = Hours Enabled > Hx 14 ... 15 = Not used 16 = Local Mode 17 = Remote 1 Mode 18 = Remote 2 Mode 19 = Run 20 = Ready 21 = STO		64h	4Eh	A2h	USINT	7762	enum	1



Parameter	Description	Range of values	Decimal places	Class	Instance	Attribute	CIP data type	Net Id	Size	Qty mapped words
		22 = No Fault 23 = With Fault 24 = No Alarm 25 = No Fault and Alarm 26 = Network 27 = SoftPLC 28 = Forward Direction 29 = Ride-Through 30 = Pre-Charge OK								
C5.3.5	Slot B-Encoder									
C5.3.5.1	Number of Pulses	1 to 65535 ppr	0	64h	4Eh	7Bh	UINT	7723	16bit	1
C5.3.5.2	Settings	Bit 0 = Broken Cable A Bit 2 = Broken Cable B Bit 4 = Broken Cable Z Bit 6 = Search Zero Bit 7 = Signal Direction		64h	4Eh	7Ch	WORD	7724	5bit	1
C5.3.6	Slot B-Temperatures									
C5.3.6.1	Sensor Type	0 = PT100 1 = PT1000 2 = Single PTC 3 = Triple PTC		64h	4Eh	92h	USINT	7746	enum	1
C5.3.6.2	Overtemperature Config.	Bit 0 = S1 Sensor F/A Bit 2 = S2 Sensor F/A Bit 4 = S3 Sensor F/A Bit 6 = S4 Sensor F/A Bit 8 = S5 Sensor F/A Bit 10 = S6 Sensor F/A		64h	4Eh	93h	WORD	7747	6bit	1
C5.3.6.3	Broken Cable Config.	Bit 0 = S1 Sensor F/A Bit 2 = S2 Sensor F/A Bit 4 = S3 Sensor F/A Bit 6 = S4 Sensor F/A Bit 8 = S5 Sensor F/A Bit 10 = S6 Sensor F/A		64h	4Eh	94h	WORD	7748	6bit	1
C5.3.6.4	Temp. 1 Sensor Setpoint	-100.0 to 250.0 °C	1	64h	4Eh	95h	INT	7749	s16bit	1
C5.3.6.5	Temp. 2 Sensor Setpoint	-100.0 to 250.0 °C	1	64h	4Eh	96h	INT	7750	s16bit	1
C5.3.6.6	Temp. 3 Sensor Setpoint	-100.0 to 250.0 °C	1	64h	4Eh	97h	INT	7751	s16bit	1
C5.3.6.7	Temp. 4 Sensor Setpoint	-100.0 to 250.0 °C	1	64h	4Eh	98h	INT	7752	s16bit	1
C5.3.6.8	Temp. 5 Sensor Setpoint	-100.0 to 250.0 °C	1	64h	4Eh	99h	INT	7753	s16bit	1
C5.3.6.9	Temp. 6 Sensor Setpoint	-100.0 to 250.0 °C	1	64h	4Eh	9Ah	INT	7754	s16bit	1
C5.4	Slot C									
C5.4.1	Slot C-Analog Inputs									
C5.4.1.1	AI1 Settings	Bit 0 = Detect Disconnection Bit 2 = Signal Setting		64h	51h	7Eh	WORD	8026	2bit	1
C5.4.1.2	AI1 Filter	0.00 to 16.00 s	2	64h	51h	82h	UINT	8030	16bit	1

Parameter	Description	Range of values	Decimal places	Class	Instance	Attribute	CIP data type	Net Id	Size	Qty mapped words
C5.4.1.3	AI1 Gain	0.000 to 9.999	3	64h	51h	86h	UINT	8034	16bit	1
C5.4.1.4	AI1 Offset	-100.00 to 100.00 %	2	64h	51h	8Ah	INT	8038	s16bit	1
C5.4.1.5	AI1 Dead Zone	0.00 to 100.00 %	2	64h	51h	8Eh	UINT	8042	16bit	1
C5.4.1.6	AI2 Settings	Bit 0 = Detect Disconnection Bit 2 = Signal Setting		64h	51h	7Fh	WORD	8027	2bit	1
C5.4.1.7	AI2 Filter	0.00 to 16.00 s	2	64h	51h	83h	UINT	8031	16bit	1
C5.4.1.8	AI2 Gain	0.000 to 9.999	3	64h	51h	87h	UINT	8035	16bit	1
C5.4.1.9	AI2 Offset	-100.00 to 100.00 %	2	64h	51h	8Bh	INT	8039	s16bit	1
C5.4.1.10	AI2 Dead Zone	0.00 to 100.00 %	2	64h	51h	8Fh	UINT	8043	16bit	1
C5.4.1.11	AI3 Settings	Bit 0 = Detect Disconnection Bit 2 = Signal Setting		64h	51h	80h	WORD	8028	2bit	1
C5.4.1.12	AI3 Filter	0.00 to 16.00 s	2	64h	51h	84h	UINT	8032	16bit	1
C5.4.1.13	AI3 Gain	0.000 to 9.999	3	64h	51h	88h	UINT	8036	16bit	1
C5.4.1.14	AI3 Offset	-100.00 to 100.00 %	2	64h	51h	8Ch	INT	8040	s16bit	1
C5.4.1.15	AI3 Dead Zone	0.00 to 100.00 %	2	64h	51h	90h	UINT	8044	16bit	1
C5.4.2	Slot C-Analog Outputs									
C5.4.2.1	AO1 Signal Type	0 = 0 to 20 mA 1 = 4 to 20 mA 2 = 20 to 0 mA 3 = 20 to 4 mA 4 = 0 to 10 V 5 = 10 to 0 V 6 ... 7 = Not used		64h	51h	B3h	USINT	8079	enum	1
C5.4.2.2	AO1 Gain	0.000 to 9.999	3	64h	51h	B7h	UINT	8083	16bit	1
C5.4.2.3	AO1 Function	0 = Off (0 %) 1 = On (100%) 2 = Speed Ref. 3 = Total Speed Ref. 4 = Real Speed 5 ... 6 = Not used 7 = Output Current 8 ... 9 = Not used 10 = Output Power 11 ... 12 = Not used 13 = Motor Torque 14 = SoftPLC 15 = PTC 16 = Motor lxt 17 = Encoder Speed 18 = Network 19 = Not used 20 = Torque Ref. 21 = Total Torque Ref.		64h	51h	BBh	USINT	8087	enum	1
C5.4.2.4	AO1 Offset	-100.00 to 100.00 %	2	64h	51h	BFh	INT	8091	s16bit	1
C5.4.2.5	AO2 Signal Type	0 = 0 to 20 mA		64h	51h	B4h	USINT	8080	enum	1



Parameter	Description	Range of values	Decimal places	Class	Instance	Attribute	CIP data type	Net Id	Size	Qty mapped words
C5.4.2.6	AO2 Gain	1 = 4 to 20 mA 2 = 20 to 0 mA 3 = 20 to 4 mA 4 = 0 to 10 V 5 = 10 to 0 V 6 ... 7 = Not used 0.000 to 9.999	3	64h	51h	B8h	UINT	8084	16bit	1
C5.4.2.7	AO2 Function	0 = Off (0 %) 1 = On (100%) 2 = Speed Ref. 3 = Total Speed Ref. 4 = Real Speed 5 ... 6 = Not used 7 = Output Current 8 ... 9 = Not used 10 = Output Power 11 ... 12 = Not used 13 = Motor Torque 14 = SoftPLC 15 = PTC 16 = Motor lxt 17 = Encoder Speed 18 = Network 19 = Not used 20 = Torque Ref. 21 = Total Torque Ref.		64h	51h	BCh	USINT	8088	enum	1
C5.4.2.8	AO2 Offset	-100.00 to 100.00 %	2	64h	51h	C0h	INT	8092	s16bit	1
C5.4.4	Slot C-Digital Outputs									
C5.4.4.1	DO1 Function	0 = Off 1 = On 2 = N* > Nx 3 = N > Nx 4 = N < Ny 5 = N = N* 6 ... 7 = Not used 8 = F > Fx 9 = Is > lx 10 = Is < lx 11 = Torque > Tx 12 = Torque < Tx 13 = Hours Enabled > Hx 14 ... 15 = Not used 16 = Local Mode 17 = Remote 1 Mode 18 = Remote 2 Mode 19 = Run 20 = Ready 21 = STO 22 = No Fault		64h	51h	9Bh	USINT	8055	enum	1



Parameter	Description	Range of values	Decimal places	Class	Instance	Attribute	CIP data type	Net Id	Size	Qty mapped words
		23 = With Fault 24 = No Alarm 25 = No Fault and Alarm 26 = Network 27 = SoftPLC 28 = Forward Direction 29 = Ride-Through 30 = Pre-Charge OK								
C5.4.4.4	DO2 Function	0 = Off 1 = On 2 = N* > Nx 3 = N > Nx 4 = N < Ny 5 = N = N* 6 ... 7 = Not used 8 = F > Fx 9 = Is > Ix 10 = Is < Ix 11 = Torque > Tx 12 = Torque < Tx 13 = Hours Enabled > Hx 14 ... 15 = Not used 16 = Local Mode 17 = Remote 1 Mode 18 = Remote 2 Mode 19 = Run 20 = Ready 21 = STO 22 = No Fault 23 = With Fault 24 = No Alarm 25 = No Fault and Alarm 26 = Network 27 = SoftPLC 28 = Forward Direction 29 = Ride-Through 30 = Pre-Charge OK		64h	51h	9Ch	USINT	8056	enum	1
C5.4.4.7	DO3 Function	0 = Off 1 = On 2 = N* > Nx 3 = N > Nx 4 = N < Ny 5 = N = N* 6 ... 7 = Not used 8 = F > Fx 9 = Is > Ix 10 = Is < Ix 11 = Torque > Tx 12 = Torque < Tx		64h	51h	9Dh	USINT	8057	enum	1



Parameter	Description	Range of values	Decimal places	Class	Instance	Attribute	CIP data type	Net Id	Size	Qty mapped words
		13 = Hours Enabled > Hx 14 ... 15 = Not used 16 = Local Mode 17 = Remote 1 Mode 18 = Remote 2 Mode 19 = Run 20 = Ready 21 = STO 22 = No Fault 23 = With Fault 24 = No Alarm 25 = No Fault and Alarm 26 = Network 27 = SoftPLC 28 = Forward Direction 29 = Ride-Through 30 = Pre-Charge OK								
C5.4.4.10	DO4 Function	0 = Off 1 = On 2 = N* > Nx 3 = N > Nx 4 = N < Ny 5 = N = N* 6 ... 7 = Not used 8 = F > Fx 9 = Is > Ix 10 = Is < Ix 11 = Torque > Tx 12 = Torque < Tx 13 = Hours Enabled > Hx 14 ... 15 = Not used 16 = Local Mode 17 = Remote 1 Mode 18 = Remote 2 Mode 19 = Run 20 = Ready 21 = STO 22 = No Fault 23 = With Fault 24 = No Alarm 25 = No Fault and Alarm 26 = Network 27 = SoftPLC 28 = Forward Direction 29 = Ride-Through 30 = Pre-Charge OK		64h	51h	9Eh	USINT	8058	enum	1
C5.4.4.13	DO5 Function	0 = Off 1 = On 2 = N* > Nx		64h	51h	9Fh	USINT	8059	enum	1



Parameter	Description	Range of values	Decimal places	Class	Instance	Attribute	CIP data type	Net Id	Size	Qty mapped words
		3 = N > Nx 4 = N < Ny 5 = N = N* 6 ... 7 = Not used 8 = F > Fx 9 = Is > Ix 10 = Is < Ix 11 = Torque > Tx 12 = Torque < Tx 13 = Hours Enabled > Hx 14 ... 15 = Not used 16 = Local Mode 17 = Remote 1 Mode 18 = Remote 2 Mode 19 = Run 20 = Ready 21 = STO 22 = No Fault 23 = With Fault 24 = No Alarm 25 = No Fault and Alarm 26 = Network 27 = SoftPLC 28 = Forward Direction 29 = Ride-Through 30 = Pre-Charge OK								
C5.4.4.16	DO6 Function	0 = Off 1 = On 2 = N* > Nx 3 = N > Nx 4 = N < Ny 5 = N = N* 6 ... 7 = Not used 8 = F > Fx 9 = Is > Ix 10 = Is < Ix 11 = Torque > Tx 12 = Torque < Tx 13 = Hours Enabled > Hx 14 ... 15 = Not used 16 = Local Mode 17 = Remote 1 Mode 18 = Remote 2 Mode 19 = Run 20 = Ready 21 = STO 22 = No Fault 23 = With Fault 24 = No Alarm 25 = No Fault and Alarm		64h	51h	A0h	USINT	8060	enum	1



Parameter	Description	Range of values	Decimal places	Class	Instance	Attribute	CIP data type	Net Id	Size	Qty mapped words
C5.4.4.19	DO7 Function	26 = Network 27 = SoftPLC 28 = Forward Direction 29 = Ride-Through 30 = Pre-Charge OK 0 = Off 1 = On 2 = N* > Nx 3 = N > Nx 4 = N < Ny 5 = N = N* 6 ... 7 = Not used 8 = F > Fx 9 = Is > lx 10 = Is < lx 11 = Torque > Tx 12 = Torque < Tx 13 = Hours Enabled > Hx 14 ... 15 = Not used 16 = Local Mode 17 = Remote 1 Mode 18 = Remote 2 Mode 19 = Run 20 = Ready 21 = STO 22 = No Fault 23 = With Fault 24 = No Alarm 25 = No Fault and Alarm 26 = Network 27 = SoftPLC 28 = Forward Direction 29 = Ride-Through 30 = Pre-Charge OK		64h	51h	A1h	USINT	8061	enum	1
C5.4.4.22	DO8 Function	0 = Off 1 = On 2 = N* > Nx 3 = N > Nx 4 = N < Ny 5 = N = N* 6 ... 7 = Not used 8 = F > Fx 9 = Is > lx 10 = Is < lx 11 = Torque > Tx 12 = Torque < Tx 13 = Hours Enabled > Hx 14 ... 15 = Not used 16 = Local Mode		64h	51h	A2h	USINT	8062	enum	1



Parameter	Description	Range of values	Decimal places	Class	Instance	Attribute	CIP data type	Net Id	Size	Qty mapped words
		17 = Remote 1 Mode 18 = Remote 2 Mode 19 = Run 20 = Ready 21 = STO 22 = No Fault 23 = With Fault 24 = No Alarm 25 = No Fault and Alarm 26 = Network 27 = SoftPLC 28 = Forward Direction 29 = Ride-Through 30 = Pre-Charge OK								
C5.4.5	Slot C-Encoder									
C5.4.5.1	Number of Pulses	1 to 65535 ppr	0	64h	51h	7Bh	UINT	8023	16bit	1
C5.4.5.2	Settings	Bit 0 = Broken Cable A Bit 2 = Broken Cable B Bit 4 = Broken Cable Z Bit 6 = Search Zero Bit 7 = Signal Direction		64h	51h	7Ch	WORD	8024	5bit	1
C5.4.6	Slot C-Temperatures									
C5.4.6.1	Sensor Type	0 = PT100 1 = PT1000 2 = Single PTC 3 = Triple PTC		64h	51h	92h	USINT	8046	enum	1
C5.4.6.2	Overtemperature Config.	Bit 0 = S1 Sensor F/A Bit 2 = S2 Sensor F/A Bit 4 = S3 Sensor F/A Bit 6 = S4 Sensor F/A Bit 8 = S5 Sensor F/A Bit 10 = S6 Sensor F/A		64h	51h	93h	WORD	8047	6bit	1
C5.4.6.3	Broken Cable Config.	Bit 0 = S1 Sensor F/A Bit 2 = S2 Sensor F/A Bit 4 = S3 Sensor F/A Bit 6 = S4 Sensor F/A Bit 8 = S5 Sensor F/A Bit 10 = S6 Sensor F/A		64h	51h	94h	WORD	8048	6bit	1
C5.4.6.4	Temp. 1 Sensor Setpoint	-100.0 to 250.0 °C	1	64h	51h	95h	INT	8049	s16bit	1
C5.4.6.5	Temp. 2 Sensor Setpoint	-100.0 to 250.0 °C	1	64h	51h	96h	INT	8050	s16bit	1
C5.4.6.6	Temp. 3 Sensor Setpoint	-100.0 to 250.0 °C	1	64h	51h	97h	INT	8051	s16bit	1
C5.4.6.7	Temp. 4 Sensor Setpoint	-100.0 to 250.0 °C	1	64h	51h	98h	INT	8052	s16bit	1
C5.4.6.8	Temp. 5 Sensor Setpoint	-100.0 to 250.0 °C	1	64h	51h	99h	INT	8053	s16bit	1
C5.4.6.9	Temp. 6 Sensor Setpoint	-100.0 to 250.0 °C	1	64h	51h	9Ah	INT	8054	s16bit	1
C5.5	Slot D									



Parameter	Description	Range of values	Decimal places	Class	Instance	Attribute	CIP data type	Net Id	Size	Qty mapped words
C5.5.1	Slot D-Analog Inputs									
C5.5.1.1	AI1 Settings	Bit 0 = Detect Disconnection Bit 2 = Signal Setting		64h	54h	7Eh	WORD	8326	2bit	1
C5.5.1.2	AI1 Filter	0.00 to 16.00 s	2	64h	54h	82h	UINT	8330	16bit	1
C5.5.1.3	AI1 Gain	0.000 to 9.999	3	64h	54h	86h	UINT	8334	16bit	1
C5.5.1.4	AI1 Offset	-100.00 to 100.00 %	2	64h	54h	8Ah	INT	8338	s16bit	1
C5.5.1.5	AI1 Dead Zone	0.00 to 100.00 %	2	64h	54h	8Eh	UINT	8342	16bit	1
C5.5.1.6	AI2 Settings	Bit 0 = Detect Disconnection Bit 2 = Signal Setting		64h	54h	7Fh	WORD	8327	2bit	1
C5.5.1.7	AI2 Filter	0.00 to 16.00 s	2	64h	54h	83h	UINT	8331	16bit	1
C5.5.1.8	AI2 Gain	0.000 to 9.999	3	64h	54h	87h	UINT	8335	16bit	1
C5.5.1.9	AI2 Offset	-100.00 to 100.00 %	2	64h	54h	8Bh	INT	8339	s16bit	1
C5.5.1.10	AI2 Dead Zone	0.00 to 100.00 %	2	64h	54h	8Fh	UINT	8343	16bit	1
C5.5.1.11	AI3 Settings	Bit 0 = Detect Disconnection Bit 2 = Signal Setting		64h	54h	80h	WORD	8328	2bit	1
C5.5.1.12	AI3 Filter	0.00 to 16.00 s	2	64h	54h	84h	UINT	8332	16bit	1
C5.5.1.13	AI3 Gain	0.000 to 9.999	3	64h	54h	88h	UINT	8336	16bit	1
C5.5.1.14	AI3 Offset	-100.00 to 100.00 %	2	64h	54h	8Ch	INT	8340	s16bit	1
C5.5.1.15	AI3 Dead Zone	0.00 to 100.00 %	2	64h	54h	90h	UINT	8344	16bit	1
C5.5.2	Slot D-Analog Outputs									
C5.5.2.1	AO1 Signal Type	0 = 0 to 20 mA 1 = 4 to 20 mA 2 = 20 to 0 mA 3 = 20 to 4 mA 4 = 0 to 10 V 5 = 10 to 0 V 6 ... 7 = Not used		64h	54h	B3h	USINT	8379	enum	1
C5.5.2.2	AO1 Gain	0.000 to 9.999	3	64h	54h	B7h	UINT	8383	16bit	1
C5.5.2.3	AO1 Function	0 = Off (0 %) 1 = On (100%) 2 = Speed Ref. 3 = Total Speed Ref. 4 = Real Speed 5 ... 6 = Not used 7 = Output Current 8 ... 9 = Not used 10 = Output Power 11 ... 12 = Not used 13 = Motor Torque 14 = SoftPLC 15 = PTC 16 = Motor lxt 17 = Encoder Speed 18 = Network 19 = Not used		64h	54h	BBh	USINT	8387	enum	1



Parameter	Description	Range of values	Decimal places	Class	Instance	Attribute	CIP data type	Net Id	Size	Qty mapped words
C5.5.2.4	AO1 Offset	20 = Torque Ref. 21 = Total Torque Ref. -100.00 to 100.00 %	2	64h	54h	BFh	INT	8391	s16bit	1
C5.5.2.5	AO2 Signal Type	0 = 0 to 20 mA 1 = 4 to 20 mA 2 = 20 to 0 mA 3 = 20 to 4 mA 4 = 0 to 10 V 5 = 10 to 0 V 6 ... 7 = Not used		64h	54h	B4h	USINT	8380	enum	1
C5.5.2.6	AO2 Gain	0.000 to 9.999	3	64h	54h	B8h	UINT	8384	16bit	1
C5.5.2.7	AO2 Function	0 = Off (0 %) 1 = On (100%) 2 = Speed Ref. 3 = Total Speed Ref. 4 = Real Speed 5 ... 6 = Not used 7 = Output Current 8 ... 9 = Not used 10 = Output Power 11 ... 12 = Not used 13 = Motor Torque 14 = SoftPLC 15 = PTC 16 = Motor lxt 17 = Encoder Speed 18 = Network 19 = Not used 20 = Torque Ref. 21 = Total Torque Ref.		64h	54h	BCh	USINT	8388	enum	1
C5.5.2.8	AO2 Offset	20 = Torque Ref. 21 = Total Torque Ref. -100.00 to 100.00 %	2	64h	54h	C0h	INT	8392	s16bit	1
C5.5.4	Slot D-Digital Outputs									
C5.5.4.1	DO1 Function	0 = Off 1 = On 2 = N* > Nx 3 = N > Nx 4 = N < Ny 5 = N = N* 6 ... 7 = Not used 8 = F > Fx 9 = Is > lx 10 = Is < lx 11 = Torque > Tx 12 = Torque < Tx 13 = Hours Enabled > Hx 14 ... 15 = Not used 16 = Local Mode		64h	54h	9Bh	USINT	8355	enum	1



Parameter	Description	Range of values	Decimal places	Class	Instance	Attribute	CIP data type	Net Id	Size	Qty mapped words
		17 = Remote 1 Mode 18 = Remote 2 Mode 19 = Run 20 = Ready 21 = STO 22 = No Fault 23 = With Fault 24 = No Alarm 25 = No Fault and Alarm 26 = Network 27 = SoftPLC 28 = Forward Direction 29 = Ride-Through 30 = Pre-Charge OK								
C5.5.4.4	DO2 Function	0 = Off 1 = On 2 = N* > Nx 3 = N > Nx 4 = N < Ny 5 = N = N* 6 ... 7 = Not used 8 = F > Fx 9 = Is > lx 10 = Is < lx 11 = Torque > Tx 12 = Torque < Tx 13 = Hours Enabled > Hx 14 ... 15 = Not used 16 = Local Mode 17 = Remote 1 Mode 18 = Remote 2 Mode 19 = Run 20 = Ready 21 = STO 22 = No Fault 23 = With Fault 24 = No Alarm 25 = No Fault and Alarm 26 = Network 27 = SoftPLC 28 = Forward Direction 29 = Ride-Through 30 = Pre-Charge OK		64h	54h	9Ch	USINT	8356	enum	1
C5.5.4.7	DO3 Function	0 = Off 1 = On 2 = N* > Nx 3 = N > Nx 4 = N < Ny 5 = N = N*		64h	54h	9Dh	USINT	8357	enum	1



Parameter	Description	Range of values	Decimal places	Class	Instance	Attribute	CIP data type	Net Id	Size	Qty mapped words
		6 ... 7 = Not used 8 = F > Fx 9 = Is > Ix 10 = Is < Ix 11 = Torque > Tx 12 = Torque < Tx 13 = Hours Enabled > Hx 14 ... 15 = Not used 16 = Local Mode 17 = Remote 1 Mode 18 = Remote 2 Mode 19 = Run 20 = Ready 21 = STO 22 = No Fault 23 = With Fault 24 = No Alarm 25 = No Fault and Alarm 26 = Network 27 = SoftPLC 28 = Forward Direction 29 = Ride-Through 30 = Pre-Charge OK								
C5.5.4.10	DO4 Function	0 = Off 1 = On 2 = N* > Nx 3 = N > Nx 4 = N < Ny 5 = N = N* 6 ... 7 = Not used 8 = F > Fx 9 = Is > Ix 10 = Is < Ix 11 = Torque > Tx 12 = Torque < Tx 13 = Hours Enabled > Hx 14 ... 15 = Not used 16 = Local Mode 17 = Remote 1 Mode 18 = Remote 2 Mode 19 = Run 20 = Ready 21 = STO 22 = No Fault 23 = With Fault 24 = No Alarm 25 = No Fault and Alarm 26 = Network 27 = SoftPLC 28 = Forward Direction		64h	54h	9Eh	USINT	8358	enum	1



Parameter	Description	Range of values	Decimal places	Class	Instance	Attribute	CIP data type	Net Id	Size	Qty mapped words
C5.5.4.13	DO5 Function	29 = Ride-Through 30 = Pre-Charge OK 0 = Off 1 = On 2 = N* > Nx 3 = N > Nx 4 = N < Ny 5 = N = N* 6 ... 7 = Not used 8 = F > Fx 9 = Is > lx 10 = Is < lx 11 = Torque > Tx 12 = Torque < Tx 13 = Hours Enabled > Hx 14 ... 15 = Not used 16 = Local Mode 17 = Remote 1 Mode 18 = Remote 2 Mode 19 = Run 20 = Ready 21 = STO 22 = No Fault 23 = With Fault 24 = No Alarm 25 = No Fault and Alarm 26 = Network 27 = SoftPLC 28 = Forward Direction 29 = Ride-Through 30 = Pre-Charge OK		64h	54h	9Fh	USINT	8359	enum	1
C5.5.4.16	DO6 Function	0 = Off 1 = On 2 = N* > Nx 3 = N > Nx 4 = N < Ny 5 = N = N* 6 ... 7 = Not used 8 = F > Fx 9 = Is > lx 10 = Is < lx 11 = Torque > Tx 12 = Torque < Tx 13 = Hours Enabled > Hx 14 ... 15 = Not used 16 = Local Mode 17 = Remote 1 Mode 18 = Remote 2 Mode 19 = Run		64h	54h	A0h	USINT	8360	enum	1



Parameter	Description	Range of values	Decimal places	Class	Instance	Attribute	CIP data type	Net Id	Size	Qty mapped words
		20 = Ready 21 = STO 22 = No Fault 23 = With Fault 24 = No Alarm 25 = No Fault and Alarm 26 = Network 27 = SoftPLC 28 = Forward Direction 29 = Ride-Through 30 = Pre-Charge OK								
C5.5.4.19	DO7 Function	0 = Off 1 = On 2 = N* > Nx 3 = N > Nx 4 = N < Ny 5 = N = N* 6 ... 7 = Not used 8 = F > Fx 9 = Is > lx 10 = Is < lx 11 = Torque > Tx 12 = Torque < Tx 13 = Hours Enabled > Hx 14 ... 15 = Not used 16 = Local Mode 17 = Remote 1 Mode 18 = Remote 2 Mode 19 = Run 20 = Ready 21 = STO 22 = No Fault 23 = With Fault 24 = No Alarm 25 = No Fault and Alarm 26 = Network 27 = SoftPLC 28 = Forward Direction 29 = Ride-Through 30 = Pre-Charge OK		64h	54h	A1h	USINT	8361	enum	1
C5.5.4.22	DO8 Function	0 = Off 1 = On 2 = N* > Nx 3 = N > Nx 4 = N < Ny 5 = N = N* 6 ... 7 = Not used 8 = F > Fx 9 = Is > lx		64h	54h	A2h	USINT	8362	enum	1



Parameter	Description	Range of values	Decimal places	Class	Instance	Attribute	CIP data type	Net Id	Size	Qty mapped words
		10 = Is < Ix 11 = Torque > Tx 12 = Torque < Tx 13 = Hours Enabled > Hx 14 ... 15 = Not used 16 = Local Mode 17 = Remote 1 Mode 18 = Remote 2 Mode 19 = Run 20 = Ready 21 = STO 22 = No Fault 23 = With Fault 24 = No Alarm 25 = No Fault and Alarm 26 = Network 27 = SoftPLC 28 = Forward Direction 29 = Ride-Through 30 = Pre-Charge OK								
C5.5.5	Slot D-Encoder									
C5.5.5.1	Number of Pulses	1 to 65535 ppr	0	64h	54h	7Bh	UINT	8323	16bit	1
C5.5.5.2	Settings	Bit 0 = Broken Cable A Bit 2 = Broken Cable B Bit 4 = Broken Cable Z Bit 6 = Search Zero Bit 7 = Signal Direction		64h	54h	7Ch	WORD	8324	5bit	1
C5.5.6	Slot D-Temperatures									
C5.5.6.1	Sensor Type	0 = PT100 1 = PT1000 2 = Single PTC 3 = Triple PTC		64h	54h	92h	USINT	8346	enum	1
C5.5.6.2	Overtemperature Config.	Bit 0 = S1 Sensor F/A Bit 2 = S2 Sensor F/A Bit 4 = S3 Sensor F/A Bit 6 = S4 Sensor F/A Bit 8 = S5 Sensor F/A Bit 10 = S6 Sensor F/A		64h	54h	93h	WORD	8347	6bit	1
C5.5.6.3	Broken Cable Config.	Bit 0 = S1 Sensor F/A Bit 2 = S2 Sensor F/A Bit 4 = S3 Sensor F/A Bit 6 = S4 Sensor F/A Bit 8 = S5 Sensor F/A Bit 10 = S6 Sensor F/A		64h	54h	94h	WORD	8348	6bit	1
C5.5.6.4	Temp. 1 Sensor Setpoint	-100.0 to 250.0 °C	1	64h	54h	95h	INT	8349	s16bit	1
C5.5.6.5	Temp. 2 Sensor Setpoint	-100.0 to 250.0 °C	1	64h	54h	96h	INT	8350	s16bit	1



Parameter	Description	Range of values	Decimal places	Class	Instance	Attribute	CIP data type	Net Id	Size	Qty mapped words
C5.5.6.6	Temp. 3 Sensor Setpoint	-100.0 to 250.0 °C	1	64h	54h	97h	INT	8351	s16bit	1
C5.5.6.7	Temp. 4 Sensor Setpoint	-100.0 to 250.0 °C	1	64h	54h	98h	INT	8352	s16bit	1
C5.5.6.8	Temp. 5 Sensor Setpoint	-100.0 to 250.0 °C	1	64h	54h	99h	INT	8353	s16bit	1
C5.5.6.9	Temp. 6 Sensor Setpoint	-100.0 to 250.0 °C	1	64h	54h	9Ah	INT	8354	s16bit	1
C5.6	Slot E									
C5.6.1	Slot E-Analog Inputs									
C5.6.1.1	AI1 Settings	Bit 0 = Detect Disconnection Bit 2 = Signal Setting		64h	57h	7Eh	WORD	8626	2bit	1
C5.6.1.2	AI1 Filter	0.00 to 16.00 s	2	64h	57h	82h	UINT	8630	16bit	1
C5.6.1.3	AI1 Gain	0.000 to 9.999	3	64h	57h	86h	UINT	8634	16bit	1
C5.6.1.4	AI1 Offset	-100.00 to 100.00 %	2	64h	57h	8Ah	INT	8638	s16bit	1
C5.6.1.5	AI1 Dead Zone	0.00 to 100.00 %	2	64h	57h	8Eh	UINT	8642	16bit	1
C5.6.1.6	AI2 Settings	Bit 0 = Detect Disconnection Bit 2 = Signal Setting		64h	57h	7Fh	WORD	8627	2bit	1
C5.6.1.7	AI2 Filter	0.00 to 16.00 s	2	64h	57h	83h	UINT	8631	16bit	1
C5.6.1.8	AI2 Gain	0.000 to 9.999	3	64h	57h	87h	UINT	8635	16bit	1
C5.6.1.9	AI2 Offset	-100.00 to 100.00 %	2	64h	57h	8Bh	INT	8639	s16bit	1
C5.6.1.10	AI2 Dead Zone	0.00 to 100.00 %	2	64h	57h	8Fh	UINT	8643	16bit	1
C5.6.1.11	AI3 Settings	Bit 0 = Detect Disconnection Bit 2 = Signal Setting		64h	57h	80h	WORD	8628	2bit	1
C5.6.1.12	AI3 Filter	0.00 to 16.00 s	2	64h	57h	84h	UINT	8632	16bit	1
C5.6.1.13	AI3 Gain	0.000 to 9.999	3	64h	57h	88h	UINT	8636	16bit	1
C5.6.1.14	AI3 Offset	-100.00 to 100.00 %	2	64h	57h	8Ch	INT	8640	s16bit	1
C5.6.1.15	AI3 Dead Zone	0.00 to 100.00 %	2	64h	57h	90h	UINT	8644	16bit	1
C5.6.2	Slot E-Analog Outputs									
C5.6.2.1	AO1 Signal Type	0 = 0 to 20 mA 1 = 4 to 20 mA 2 = 20 to 0 mA 3 = 20 to 4 mA 4 = 0 to 10 V 5 = 10 to 0 V 6 ... 7 = Not used		64h	57h	B3h	USINT	8679	enum	1
C5.6.2.2	AO1 Gain	0.000 to 9.999	3	64h	57h	B7h	UINT	8683	16bit	1
C5.6.2.3	AO1 Function	0 = Off (0 %) 1 = On (100%) 2 = Speed Ref. 3 = Total Speed Ref. 4 = Real Speed 5 ... 6 = Not used 7 = Output Current 8 ... 9 = Not used 10 = Output Power 11 ... 12 = Not used 13 = Motor Torque 14 = SoftPLC		64h	57h	BBh	USINT	8687	enum	1



Parameter	Description	Range of values	Decimal places	Class	Instance	Attribute	CIP data type	Net Id	Size	Qty mapped words
C5.6.2.4	AO1 Offset	15 = PTC 16 = Motor lxt 17 = Encoder Speed 18 = Network 19 = Not used 20 = Torque Ref. 21 = Total Torque Ref. -100.00 to 100.00 %	2	64h	57h	BFh	INT	8691	s16bit	1
C5.6.2.5	AO2 Signal Type	0 = 0 to 20 mA 1 = 4 to 20 mA 2 = 20 to 0 mA 3 = 20 to 4 mA 4 = 0 to 10 V 5 = 10 to 0 V 6 ... 7 = Not used		64h	57h	B4h	USINT	8680	enum	1
C5.6.2.6	AO2 Gain	0.000 to 9.999	3	64h	57h	B8h	UINT	8684	16bit	1
C5.6.2.7	AO2 Function	0 = Off (0 %) 1 = On (100%) 2 = Speed Ref. 3 = Total Speed Ref. 4 = Real Speed 5 ... 6 = Not used 7 = Output Current 8 ... 9 = Not used 10 = Output Power 11 ... 12 = Not used 13 = Motor Torque 14 = SoftPLC 15 = PTC 16 = Motor lxt 17 = Encoder Speed 18 = Network 19 = Not used 20 = Torque Ref. 21 = Total Torque Ref.		64h	57h	BCh	USINT	8688	enum	1
C5.6.2.8	AO2 Offset	-100.00 to 100.00 %	2	64h	57h	C0h	INT	8692	s16bit	1
C5.6.4	Slot E-Digital Outputs									
C5.6.4.1	DO1 Function	0 = Off 1 = On 2 = N* > Nx 3 = N > Nx 4 = N < Ny 5 = N = N* 6 ... 7 = Not used 8 = F > Fx 9 = ls > lx 10 = ls < lx		64h	57h	9Bh	USINT	8655	enum	1



Parameter	Description	Range of values	Decimal places	Class	Instance	Attribute	CIP data type	Net Id	Size	Qty mapped words
		11 = Torque > Tx 12 = Torque < Tx 13 = Hours Enabled > Hx 14 ... 15 = Not used 16 = Local Mode 17 = Remote 1 Mode 18 = Remote 2 Mode 19 = Run 20 = Ready 21 = STO 22 = No Fault 23 = With Fault 24 = No Alarm 25 = No Fault and Alarm 26 = Network 27 = SoftPLC 28 = Forward Direction 29 = Ride-Through 30 = Pre-Charge OK								
C5.6.4.4	DO2 Function	0 = Off 1 = On 2 = N* > Nx 3 = N > Nx 4 = N < Ny 5 = N = N* 6 ... 7 = Not used 8 = F > Fx 9 = Is > Ix 10 = Is < Ix 11 = Torque > Tx 12 = Torque < Tx 13 = Hours Enabled > Hx 14 ... 15 = Not used 16 = Local Mode 17 = Remote 1 Mode 18 = Remote 2 Mode 19 = Run 20 = Ready 21 = STO 22 = No Fault 23 = With Fault 24 = No Alarm 25 = No Fault and Alarm 26 = Network 27 = SoftPLC 28 = Forward Direction 29 = Ride-Through 30 = Pre-Charge OK		64h	57h	9Ch	USINT	8656	enum	1
C5.6.4.7	DO3 Function	0 = Off		64h	57h	9Dh	USINT	8657	enum	1



Parameter	Description	Range of values	Decimal places	Class	Instance	Attribute	CIP data type	Net Id	Size	Qty mapped words
		1 = On 2 = N* > Nx 3 = N > Nx 4 = N < Ny 5 = N = N* 6 ... 7 = Not used 8 = F > Fx 9 = Is > lx 10 = Is < lx 11 = Torque > Tx 12 = Torque < Tx 13 = Hours Enabled > Hx 14 ... 15 = Not used 16 = Local Mode 17 = Remote 1 Mode 18 = Remote 2 Mode 19 = Run 20 = Ready 21 = STO 22 = No Fault 23 = With Fault 24 = No Alarm 25 = No Fault and Alarm 26 = Network 27 = SoftPLC 28 = Forward Direction 29 = Ride-Through 30 = Pre-Charge OK								
C5.6.4.10	DO4 Function	0 = Off 1 = On 2 = N* > Nx 3 = N > Nx 4 = N < Ny 5 = N = N* 6 ... 7 = Not used 8 = F > Fx 9 = Is > lx 10 = Is < lx 11 = Torque > Tx 12 = Torque < Tx 13 = Hours Enabled > Hx 14 ... 15 = Not used 16 = Local Mode 17 = Remote 1 Mode 18 = Remote 2 Mode 19 = Run 20 = Ready 21 = STO 22 = No Fault 23 = With Fault		64h	57h	9Eh	USINT	8658	enum	1



Parameter	Description	Range of values	Decimal places	Class	Instance	Attribute	CIP data type	Net Id	Size	Qty mapped words
C5.6.4.13	DO5 Function	24 = No Alarm 25 = No Fault and Alarm 26 = Network 27 = SoftPLC 28 = Forward Direction 29 = Ride-Through 30 = Pre-Charge OK		64h	57h	9Fh	USINT	8659	enum	1
C5.6.4.16	DO6 Function	0 = Off 1 = On 2 = N* > Nx 3 = N > Nx 4 = N < Ny 5 = N = N* 6 ... 7 = Not used 8 = F > Fx 9 = Is > Ix 10 = Is < Ix 11 = Torque > Tx 12 = Torque < Tx 13 = Hours Enabled > Hx 14 ... 15 = Not used 16 = Local Mode 17 = Remote 1 Mode 18 = Remote 2 Mode 19 = Run 20 = Ready 21 = STO 22 = No Fault 23 = With Fault 24 = No Alarm 25 = No Fault and Alarm 26 = Network 27 = SoftPLC 28 = Forward Direction 29 = Ride-Through 30 = Pre-Charge OK		64h	57h	A0h	USINT	8660	enum	1



Parameter	Description	Range of values	Decimal places	Class	Instance	Attribute	CIP data type	Net Id	Size	Qty mapped words
		14 ... 15 = Not used 16 = Local Mode 17 = Remote 1 Mode 18 = Remote 2 Mode 19 = Run 20 = Ready 21 = STO 22 = No Fault 23 = With Fault 24 = No Alarm 25 = No Fault and Alarm 26 = Network 27 = SoftPLC 28 = Forward Direction 29 = Ride-Through 30 = Pre-Charge OK								
C5.6.4.19	DO7 Function	0 = Off 1 = On 2 = N* > Nx 3 = N > Nx 4 = N < Ny 5 = N = N* 6 ... 7 = Not used 8 = F > Fx 9 = Is > Ix 10 = Is < Ix 11 = Torque > Tx 12 = Torque < Tx 13 = Hours Enabled > Hx 14 ... 15 = Not used 16 = Local Mode 17 = Remote 1 Mode 18 = Remote 2 Mode 19 = Run 20 = Ready 21 = STO 22 = No Fault 23 = With Fault 24 = No Alarm 25 = No Fault and Alarm 26 = Network 27 = SoftPLC 28 = Forward Direction 29 = Ride-Through 30 = Pre-Charge OK		64h	57h	A1h	USINT	8661	enum	1
C5.6.4.22	DO8 Function	0 = Off 1 = On 2 = N* > Nx 3 = N > Nx		64h	57h	A2h	USINT	8662	enum	1



Parameter	Description	Range of values	Decimal places	Class	Instance	Attribute	CIP data type	Net Id	Size	Qty mapped words
		4 = N < Ny 5 = N = N* 6 ... 7 = Not used 8 = F > Fx 9 = Is > lx 10 = Is < lx 11 = Torque > Tx 12 = Torque < Tx 13 = Hours Enabled > Hx 14 ... 15 = Not used 16 = Local Mode 17 = Remote 1 Mode 18 = Remote 2 Mode 19 = Run 20 = Ready 21 = STO 22 = No Fault 23 = With Fault 24 = No Alarm 25 = No Fault and Alarm 26 = Network 27 = SoftPLC 28 = Forward Direction 29 = Ride-Through 30 = Pre-Charge OK								
C5.6.5	Slot E-Encoder									
C5.6.5.1	Number of Pulses	1 to 65535 ppr	0	64h	57h	7Bh	UINT	8623	16bit	1
C5.6.5.2	Settings	Bit 0 = Broken Cable A Bit 2 = Broken Cable B Bit 4 = Broken Cable Z Bit 6 = Search Zero Bit 7 = Signal Direction		64h	57h	7Ch	WORD	8624	5bit	1
C5.6.6	Slot E-Temperatures									
C5.6.6.1	Sensor Type	0 = PT100 1 = PT1000 2 = Single PTC 3 = Triple PTC		64h	57h	92h	USINT	8646	enum	1
C5.6.6.2	Overtemperature Config.	Bit 0 = S1 Sensor F/A Bit 2 = S2 Sensor F/A Bit 4 = S3 Sensor F/A Bit 6 = S4 Sensor F/A Bit 8 = S5 Sensor F/A Bit 10 = S6 Sensor F/A		64h	57h	93h	WORD	8647	6bit	1
C5.6.6.3	Broken Cable Config.	Bit 0 = S1 Sensor F/A Bit 2 = S2 Sensor F/A Bit 4 = S3 Sensor F/A		64h	57h	94h	WORD	8648	6bit	1



Parameter	Description	Range of values	Decimal places	Class	Instance	Attribute	CIP data type	Net Id	Size	Qty mapped words
		Bit 6 = S4 Sensor F/A Bit 8 = S5 Sensor F/A Bit 10 = S6 Sensor F/A								
C5.6.6.4	Temp. 1 Sensor Setpoint	-100.0 to 250.0 °C	1	64h	57h	95h	INT	8649	s16bit	1
C5.6.6.5	Temp. 2 Sensor Setpoint	-100.0 to 250.0 °C	1	64h	57h	96h	INT	8650	s16bit	1
C5.6.6.6	Temp. 3 Sensor Setpoint	-100.0 to 250.0 °C	1	64h	57h	97h	INT	8651	s16bit	1
C5.6.6.7	Temp. 4 Sensor Setpoint	-100.0 to 250.0 °C	1	64h	57h	98h	INT	8652	s16bit	1
C5.6.6.8	Temp. 5 Sensor Setpoint	-100.0 to 250.0 °C	1	64h	57h	99h	INT	8653	s16bit	1
C5.6.6.9	Temp. 6 Sensor Setpoint	-100.0 to 250.0 °C	1	64h	57h	9Ah	INT	8654	s16bit	1
C5.7	Slot F									
C5.7.1	Slot F-Analog Inputs									
C5.7.1.1	AI1 Settings	Bit 0 = Detect Disconnection Bit 2 = Signal Setting		64h	5Ah	7Eh	WORD	8926	2bit	1
C5.7.1.2	AI1 Filter	0.00 to 16.00 s	2	64h	5Ah	82h	UINT	8930	16bit	1
C5.7.1.3	AI1 Gain	0.000 to 9.999	3	64h	5Ah	86h	UINT	8934	16bit	1
C5.7.1.4	AI1 Offset	-100.00 to 100.00 %	2	64h	5Ah	8Ah	INT	8938	s16bit	1
C5.7.1.5	AI1 Dead Zone	0.00 to 100.00 %	2	64h	5Ah	8Eh	UINT	8942	16bit	1
C5.7.1.6	AI2 Settings	Bit 0 = Detect Disconnection Bit 2 = Signal Setting		64h	5Ah	7Fh	WORD	8927	2bit	1
C5.7.1.7	AI2 Filter	0.00 to 16.00 s	2	64h	5Ah	83h	UINT	8931	16bit	1
C5.7.1.8	AI2 Gain	0.000 to 9.999	3	64h	5Ah	87h	UINT	8935	16bit	1
C5.7.1.9	AI2 Offset	-100.00 to 100.00 %	2	64h	5Ah	8Bh	INT	8939	s16bit	1
C5.7.1.10	AI2 Dead Zone	0.00 to 100.00 %	2	64h	5Ah	8Fh	UINT	8943	16bit	1
C5.7.1.11	AI3 Settings	Bit 0 = Detect Disconnection Bit 2 = Signal Setting		64h	5Ah	80h	WORD	8928	2bit	1
C5.7.1.12	AI3 Filter	0.00 to 16.00 s	2	64h	5Ah	84h	UINT	8932	16bit	1
C5.7.1.13	AI3 Gain	0.000 to 9.999	3	64h	5Ah	88h	UINT	8936	16bit	1
C5.7.1.14	AI3 Offset	-100.00 to 100.00 %	2	64h	5Ah	8Ch	INT	8940	s16bit	1
C5.7.1.15	AI3 Dead Zone	0.00 to 100.00 %	2	64h	5Ah	90h	UINT	8944	16bit	1
C5.7.2	Slot F-Analog Outputs									
C5.7.2.1	AO1 Signal Type	0 = 0 to 20 mA 1 = 4 to 20 mA 2 = 20 to 0 mA 3 = 20 to 4 mA 4 = 0 to 10 V 5 = 10 to 0 V 6 ... 7 = Not used		64h	5Ah	B3h	USINT	8979	enum	1
C5.7.2.2	AO1 Gain	0.000 to 9.999	3	64h	5Ah	B7h	UINT	8983	16bit	1
C5.7.2.3	AO1 Function	0 = Off (0 %) 1 = On (100%) 2 = Speed Ref. 3 = Total Speed Ref. 4 = Real Speed 5 ... 6 = Not used		64h	5Ah	BBh	USINT	8987	enum	1



Parameter	Description	Range of values	Decimal places	Class	Instance	Attribute	CIP data type	Net Id	Size	Qty mapped words
		7 = Output Current 8 ... 9 = Not used 10 = Output Power 11 ... 12 = Not used 13 = Motor Torque 14 = SoftPLC 15 = PTC 16 = Motor Ixt 17 = Encoder Speed 18 = Network 19 = Not used 20 = Torque Ref. 21 = Total Torque Ref.								
C5.7.2.4	AO1 Offset	-100.00 to 100.00 %	2	64h	5Ah	BFh	INT	8991	s16bit	1
C5.7.2.5	AO2 Signal Type	0 = 0 to 20 mA 1 = 4 to 20 mA 2 = 20 to 0 mA 3 = 20 to 4 mA 4 = 0 to 10 V 5 = 10 to 0 V 6 ... 7 = Not used		64h	5Ah	B4h	USINT	8980	enum	1
C5.7.2.6	AO2 Gain	0.000 to 9.999	3	64h	5Ah	B8h	UINT	8984	16bit	1
C5.7.2.7	AO2 Function	0 = Off (0 %) 1 = On (100%) 2 = Speed Ref. 3 = Total Speed Ref. 4 = Real Speed 5 ... 6 = Not used 7 = Output Current 8 ... 9 = Not used 10 = Output Power 11 ... 12 = Not used 13 = Motor Torque 14 = SoftPLC 15 = PTC 16 = Motor Ixt 17 = Encoder Speed 18 = Network 19 = Not used 20 = Torque Ref. 21 = Total Torque Ref.		64h	5Ah	BCh	USINT	8988	enum	1
C5.7.2.8	AO2 Offset	-100.00 to 100.00 %	2	64h	5Ah	C0h	INT	8992	s16bit	1
C5.7.4	Slot F-Digital Outputs									
C5.7.4.1	DO1 Function	0 = Off 1 = On 2 = N* > Nx 3 = N > Nx		64h	5Ah	9Bh	USINT	8955	enum	1



Parameter	Description	Range of values	Decimal places	Class	Instance	Attribute	CIP data type	Net Id	Size	Qty mapped words
		4 = N < Ny 5 = N = N* 6 ... 7 = Not used 8 = F > Fx 9 = Is > Ix 10 = Is < Ix 11 = Torque > Tx 12 = Torque < Tx 13 = Hours Enabled > Hx 14 ... 15 = Not used 16 = Local Mode 17 = Remote 1 Mode 18 = Remote 2 Mode 19 = Run 20 = Ready 21 = STO 22 = No Fault 23 = With Fault 24 = No Alarm 25 = No Fault and Alarm 26 = Network 27 = SoftPLC 28 = Forward Direction 29 = Ride-Through 30 = Pre-Charge OK								
C5.7.4.4	DO2 Function	0 = Off 1 = On 2 = N* > Nx 3 = N > Nx 4 = N < Ny 5 = N = N* 6 ... 7 = Not used 8 = F > Fx 9 = Is > Ix 10 = Is < Ix 11 = Torque > Tx 12 = Torque < Tx 13 = Hours Enabled > Hx 14 ... 15 = Not used 16 = Local Mode 17 = Remote 1 Mode 18 = Remote 2 Mode 19 = Run 20 = Ready 21 = STO 22 = No Fault 23 = With Fault 24 = No Alarm 25 = No Fault and Alarm 26 = Network		64h	5Ah	9Ch	USINT	8956	enum	1



Parameter	Description	Range of values	Decimal places	Class	Instance	Attribute	CIP data type	Net Id	Size	Qty mapped words
C5.7.4.7	DO3 Function	27 = SoftPLC 28 = Forward Direction 29 = Ride-Through 30 = Pre-Charge OK 0 = Off 1 = On 2 = N* > Nx 3 = N > Nx 4 = N < Ny 5 = N = N* 6 ... 7 = Not used 8 = F > Fx 9 = Is > lx 10 = Is < lx 11 = Torque > Tx 12 = Torque < Tx 13 = Hours Enabled > Hx 14 ... 15 = Not used 16 = Local Mode 17 = Remote 1 Mode 18 = Remote 2 Mode 19 = Run 20 = Ready 21 = STO 22 = No Fault 23 = With Fault 24 = No Alarm 25 = No Fault and Alarm 26 = Network 27 = SoftPLC 28 = Forward Direction 29 = Ride-Through 30 = Pre-Charge OK		64h	5Ah	9Dh	USINT	8957	enum	1
C5.7.4.10	DO4 Function	0 = Off 1 = On 2 = N* > Nx 3 = N > Nx 4 = N < Ny 5 = N = N* 6 ... 7 = Not used 8 = F > Fx 9 = Is > lx 10 = Is < lx 11 = Torque > Tx 12 = Torque < Tx 13 = Hours Enabled > Hx 14 ... 15 = Not used 16 = Local Mode 17 = Remote 1 Mode		64h	5Ah	9Eh	USINT	8958	enum	1



Parameter	Description	Range of values	Decimal places	Class	Instance	Attribute	CIP data type	Net Id	Size	Qty mapped words
		18 = Remote 2 Mode 19 = Run 20 = Ready 21 = STO 22 = No Fault 23 = With Fault 24 = No Alarm 25 = No Fault and Alarm 26 = Network 27 = SoftPLC 28 = Forward Direction 29 = Ride-Through 30 = Pre-Charge OK								
C5.7.4.13	DO5 Function	0 = Off 1 = On 2 = N* > Nx 3 = N > Nx 4 = N < Ny 5 = N = N* 6 ... 7 = Not used 8 = F > Fx 9 = Is > lx 10 = Is < lx 11 = Torque > Tx 12 = Torque < Tx 13 = Hours Enabled > Hx 14 ... 15 = Not used 16 = Local Mode 17 = Remote 1 Mode 18 = Remote 2 Mode 19 = Run 20 = Ready 21 = STO 22 = No Fault 23 = With Fault 24 = No Alarm 25 = No Fault and Alarm 26 = Network 27 = SoftPLC 28 = Forward Direction 29 = Ride-Through 30 = Pre-Charge OK		64h	5Ah	9Fh	USINT	8959	enum	1
C5.7.4.16	DO6 Function	0 = Off 1 = On 2 = N* > Nx 3 = N > Nx 4 = N < Ny 5 = N = N* 6 ... 7 = Not used		64h	5Ah	A0h	USINT	8960	enum	1



Parameter	Description	Range of values	Decimal places	Class	Instance	Attribute	CIP data type	Net Id	Size	Qty mapped words
		8 = F > Fx 9 = Is > Ix 10 = Is < Ix 11 = Torque > Tx 12 = Torque < Tx 13 = Hours Enabled > Hx 14 ... 15 = Not used 16 = Local Mode 17 = Remote 1 Mode 18 = Remote 2 Mode 19 = Run 20 = Ready 21 = STO 22 = No Fault 23 = With Fault 24 = No Alarm 25 = No Fault and Alarm 26 = Network 27 = SoftPLC 28 = Forward Direction 29 = Ride-Through 30 = Pre-Charge OK								
C5.7.4.19	DO7 Function	0 = Off 1 = On 2 = N* > Nx 3 = N > Nx 4 = N < Ny 5 = N = N* 6 ... 7 = Not used 8 = F > Fx 9 = Is > Ix 10 = Is < Ix 11 = Torque > Tx 12 = Torque < Tx 13 = Hours Enabled > Hx 14 ... 15 = Not used 16 = Local Mode 17 = Remote 1 Mode 18 = Remote 2 Mode 19 = Run 20 = Ready 21 = STO 22 = No Fault 23 = With Fault 24 = No Alarm 25 = No Fault and Alarm 26 = Network 27 = SoftPLC 28 = Forward Direction 29 = Ride-Through		64h	5Ah	A1h	USINT	8961	enum	1



Parameter	Description	Range of values	Decimal places	Class	Instance	Attribute	CIP data type	Net Id	Size	Qty mapped words
C5.7.4.22	DO8 Function	30 = Pre-Charge OK 0 = Off 1 = On 2 = N* > Nx 3 = N > Nx 4 = N < Ny 5 = N = N* 6 ... 7 = Not used 8 = F > Fx 9 = Is > Ix 10 = Is < Ix 11 = Torque > Tx 12 = Torque < Tx 13 = Hours Enabled > Hx 14 ... 15 = Not used 16 = Local Mode 17 = Remote 1 Mode 18 = Remote 2 Mode 19 = Run 20 = Ready 21 = STO 22 = No Fault 23 = With Fault 24 = No Alarm 25 = No Fault and Alarm 26 = Network 27 = SoftPLC 28 = Forward Direction 29 = Ride-Through 30 = Pre-Charge OK		64h	5Ah	A2h	USINT	8962	enum	1
C5.7.5	Slot F-Encoder									
C5.7.5.1	Number of Pulses	1 to 65535 ppr	0	64h	5Ah	7Bh	UINT	8923	16bit	1
C5.7.5.2	Settings	Bit 0 = Broken Cable A Bit 2 = Broken Cable B Bit 4 = Broken Cable Z Bit 6 = Search Zero Bit 7 = Signal Direction		64h	5Ah	7Ch	WORD	8924	5bit	1
C5.7.6	Slot F-Temperatures									
C5.7.6.1	Sensor Type	0 = PT100 1 = PT1000 2 = Single PTC 3 = Triple PTC		64h	5Ah	92h	USINT	8946	enum	1
C5.7.6.2	Overtemperature Config.	Bit 0 = S1 Sensor F/A Bit 2 = S2 Sensor F/A Bit 4 = S3 Sensor F/A Bit 6 = S4 Sensor F/A		64h	5Ah	93h	WORD	8947	6bit	1



Parameter	Description	Range of values	Decimal places	Class	Instance	Attribute	CIP data type	Net Id	Size	Qty mapped words
C5.7.6.3	Broken Cable Config.	Bit 8 = S5 Sensor F/A Bit 10 = S6 Sensor F/A		64h	5Ah	94h	WORD	8948	6bit	1
C5.7.6.4	Temp. 1 Sensor Setpoint	Bit 0 = S1 Sensor F/A Bit 2 = S2 Sensor F/A Bit 4 = S3 Sensor F/A Bit 6 = S4 Sensor F/A Bit 8 = S5 Sensor F/A Bit 10 = S6 Sensor F/A -100.0 to 250.0 °C	1	64h	5Ah	95h	INT	8949	s16bit	1
C5.7.6.5	Temp. 2 Sensor Setpoint	-100.0 to 250.0 °C	1	64h	5Ah	96h	INT	8950	s16bit	1
C5.7.6.6	Temp. 3 Sensor Setpoint	-100.0 to 250.0 °C	1	64h	5Ah	97h	INT	8951	s16bit	1
C5.7.6.7	Temp. 4 Sensor Setpoint	-100.0 to 250.0 °C	1	64h	5Ah	98h	INT	8952	s16bit	1
C5.7.6.8	Temp. 5 Sensor Setpoint	-100.0 to 250.0 °C	1	64h	5Ah	99h	INT	8953	s16bit	1
C5.7.6.9	Temp. 6 Sensor Setpoint	-100.0 to 250.0 °C	1	64h	5Ah	9Ah	INT	8954	s16bit	1
C5.8	Slot G									
C5.8.1	Slot G-Analog Inputs									
C5.8.1.1	A11 Settings	Bit 0 = Detect Disconnection Bit 2 = Signal Setting		64h	5Dh	7Eh	WORD	9226	2bit	1
C5.8.1.2	A11 Filter	0.00 to 16.00 s	2	64h	5Dh	82h	UINT	9230	16bit	1
C5.8.1.3	A11 Gain	0.000 to 9.999	3	64h	5Dh	86h	UINT	9234	16bit	1
C5.8.1.4	A11 Offset	-100.00 to 100.00 %	2	64h	5Dh	8Ah	INT	9238	s16bit	1
C5.8.1.5	A11 Dead Zone	0.00 to 100.00 %	2	64h	5Dh	8Eh	UINT	9242	16bit	1
C5.8.1.6	A12 Settings	Bit 0 = Detect Disconnection Bit 2 = Signal Setting		64h	5Dh	7Fh	WORD	9227	2bit	1
C5.8.1.7	A12 Filter	0.00 to 16.00 s	2	64h	5Dh	83h	UINT	9231	16bit	1
C5.8.1.8	A12 Gain	0.000 to 9.999	3	64h	5Dh	87h	UINT	9235	16bit	1
C5.8.1.9	A12 Offset	-100.00 to 100.00 %	2	64h	5Dh	8Bh	INT	9239	s16bit	1
C5.8.1.10	A12 Dead Zone	0.00 to 100.00 %	2	64h	5Dh	8Fh	UINT	9243	16bit	1
C5.8.1.11	A13 Settings	Bit 0 = Detect Disconnection Bit 2 = Signal Setting		64h	5Dh	80h	WORD	9228	2bit	1
C5.8.1.12	A13 Filter	0.00 to 16.00 s	2	64h	5Dh	84h	UINT	9232	16bit	1
C5.8.1.13	A13 Gain	0.000 to 9.999	3	64h	5Dh	88h	UINT	9236	16bit	1
C5.8.1.14	A13 Offset	-100.00 to 100.00 %	2	64h	5Dh	8Ch	INT	9240	s16bit	1
C5.8.1.15	A13 Dead Zone	0.00 to 100.00 %	2	64h	5Dh	90h	UINT	9244	16bit	1
C5.8.2	Slot G-Analog Outputs									
C5.8.2.1	AO1 Signal Type	0 = 0 to 20 mA 1 = 4 to 20 mA 2 = 20 to 0 mA 3 = 20 to 4 mA 4 = 0 to 10 V 5 = 10 to 0 V 6 ... 7 = Not used		64h	5Dh	B3h	USINT	9279	enum	1
C5.8.2.2	AO1 Gain	0.000 to 9.999	3	64h	5Dh	B7h	UINT	9283	16bit	1
C5.8.2.3	AO1 Function			64h	5Dh	BBh	USINT	9287	enum	1



Parameter	Description	Range of values	Decimal places	Class	Instance	Attribute	CIP data type	Net Id	Size	Qty mapped words
		0 = Off (0 %) 1 = On (100%) 2 = Speed Ref. 3 = Total Speed Ref. 4 = Real Speed 5 ... 6 = Not used 7 = Output Current 8 ... 9 = Not used 10 = Output Power 11 ... 12 = Not used 13 = Motor Torque 14 = SoftPLC 15 = PTC 16 = Motor lxt 17 = Encoder Speed 18 = Network 19 = Not used 20 = Torque Ref. 21 = Total Torque Ref.								
C5.8.2.4	AO1 Offset	-100.00 to 100.00 %	2	64h	5Dh	BFh	INT	9291	s16bit	1
C5.8.2.5	AO2 Signal Type	0 = 0 to 20 mA 1 = 4 to 20 mA 2 = 20 to 0 mA 3 = 20 to 4 mA 4 = 0 to 10 V 5 = 10 to 0 V 6 ... 7 = Not used		64h	5Dh	B4h	USINT	9280	enum	1
C5.8.2.6	AO2 Gain	0.000 to 9.999	3	64h	5Dh	B8h	UINT	9284	16bit	1
C5.8.2.7	AO2 Function	0 = Off (0 %) 1 = On (100%) 2 = Speed Ref. 3 = Total Speed Ref. 4 = Real Speed 5 ... 6 = Not used 7 = Output Current 8 ... 9 = Not used 10 = Output Power 11 ... 12 = Not used 13 = Motor Torque 14 = SoftPLC 15 = PTC 16 = Motor lxt 17 = Encoder Speed 18 = Network 19 = Not used 20 = Torque Ref. 21 = Total Torque Ref.		64h	5Dh	BCh	USINT	9288	enum	1
C5.8.2.8	AO2 Offset	-100.00 to 100.00 %	2	64h	5Dh	C0h	INT	9292	s16bit	1
C5.8.4	Slot G-Digital Outputs									



Parameter	Description	Range of values	Decimal places	Class	Instance	Attribute	CIP data type	Net Id	Size	Qty mapped words
C5.8.4.1	DO1 Function	0 = Off 1 = On 2 = N* > Nx 3 = N > Nx 4 = N < Ny 5 = N = N* 6 ... 7 = Not used 8 = F > Fx 9 = Is > lx 10 = Is < lx 11 = Torque > Tx 12 = Torque < Tx 13 = Hours Enabled > Hx 14 ... 15 = Not used 16 = Local Mode 17 = Remote 1 Mode 18 = Remote 2 Mode 19 = Run 20 = Ready 21 = STO 22 = No Fault 23 = With Fault 24 = No Alarm 25 = No Fault and Alarm 26 = Network 27 = SoftPLC 28 = Forward Direction 29 = Ride-Through 30 = Pre-Charge OK		64h	5Dh	9Bh	USINT	9255	enum	1
C5.8.4.4	DO2 Function	0 = Off 1 = On 2 = N* > Nx 3 = N > Nx 4 = N < Ny 5 = N = N* 6 ... 7 = Not used 8 = F > Fx 9 = Is > lx 10 = Is < lx 11 = Torque > Tx 12 = Torque < Tx 13 = Hours Enabled > Hx 14 ... 15 = Not used 16 = Local Mode 17 = Remote 1 Mode 18 = Remote 2 Mode 19 = Run 20 = Ready 21 = STO		64h	5Dh	9Ch	USINT	9256	enum	1



Parameter	Description	Range of values	Decimal places	Class	Instance	Attribute	CIP data type	Net Id	Size	Qty mapped words
		22 = No Fault 23 = With Fault 24 = No Alarm 25 = No Fault and Alarm 26 = Network 27 = SoftPLC 28 = Forward Direction 29 = Ride-Through 30 = Pre-Charge OK								
C5.8.4.7	DO3 Function	0 = Off 1 = On 2 = N* > Nx 3 = N > Nx 4 = N < Ny 5 = N = N* 6 ... 7 = Not used 8 = F > Fx 9 = Is > Ix 10 = Is < Ix 11 = Torque > Tx 12 = Torque < Tx 13 = Hours Enabled > Hx 14 ... 15 = Not used 16 = Local Mode 17 = Remote 1 Mode 18 = Remote 2 Mode 19 = Run 20 = Ready 21 = STO 22 = No Fault 23 = With Fault 24 = No Alarm 25 = No Fault and Alarm 26 = Network 27 = SoftPLC 28 = Forward Direction 29 = Ride-Through 30 = Pre-Charge OK		64h	5Dh	9Dh	USINT	9257	enum	1
C5.8.4.10	DO4 Function	0 = Off 1 = On 2 = N* > Nx 3 = N > Nx 4 = N < Ny 5 = N = N* 6 ... 7 = Not used 8 = F > Fx 9 = Is > Ix 10 = Is < Ix 11 = Torque > Tx		64h	5Dh	9Eh	USINT	9258	enum	1



Parameter	Description	Range of values	Decimal places	Class	Instance	Attribute	CIP data type	Net Id	Size	Qty mapped words
		12 = Torque < Tx 13 = Hours Enabled > Hx 14 ... 15 = Not used 16 = Local Mode 17 = Remote 1 Mode 18 = Remote 2 Mode 19 = Run 20 = Ready 21 = STO 22 = No Fault 23 = With Fault 24 = No Alarm 25 = No Fault and Alarm 26 = Network 27 = SoftPLC 28 = Forward Direction 29 = Ride-Through 30 = Pre-Charge OK								
C5.8.4.13	DO5 Function	0 = Off 1 = On 2 = N* > Nx 3 = N > Nx 4 = N < Ny 5 = N = N* 6 ... 7 = Not used 8 = F > Fx 9 = Is > lx 10 = Is < lx 11 = Torque > Tx 12 = Torque < Tx 13 = Hours Enabled > Hx 14 ... 15 = Not used 16 = Local Mode 17 = Remote 1 Mode 18 = Remote 2 Mode 19 = Run 20 = Ready 21 = STO 22 = No Fault 23 = With Fault 24 = No Alarm 25 = No Fault and Alarm 26 = Network 27 = SoftPLC 28 = Forward Direction 29 = Ride-Through 30 = Pre-Charge OK		64h	5Dh	9Fh	USINT	9259	enum	1
C5.8.4.16	DO6 Function	0 = Off 1 = On		64h	5Dh	A0h	USINT	9260	enum	1



Parameter	Description	Range of values	Decimal places	Class	Instance	Attribute	CIP data type	Net Id	Size	Qty mapped words
		2 = N* > Nx 3 = N > Nx 4 = N < Ny 5 = N = N* 6 ... 7 = Not used 8 = F > Fx 9 = Is > lx 10 = Is < lx 11 = Torque > Tx 12 = Torque < Tx 13 = Hours Enabled > Hx 14 ... 15 = Not used 16 = Local Mode 17 = Remote 1 Mode 18 = Remote 2 Mode 19 = Run 20 = Ready 21 = STO 22 = No Fault 23 = With Fault 24 = No Alarm 25 = No Fault and Alarm 26 = Network 27 = SoftPLC 28 = Forward Direction 29 = Ride-Through 30 = Pre-Charge OK								
C5.8.4.19	DO7 Function	0 = Off 1 = On 2 = N* > Nx 3 = N > Nx 4 = N < Ny 5 = N = N* 6 ... 7 = Not used 8 = F > Fx 9 = Is > lx 10 = Is < lx 11 = Torque > Tx 12 = Torque < Tx 13 = Hours Enabled > Hx 14 ... 15 = Not used 16 = Local Mode 17 = Remote 1 Mode 18 = Remote 2 Mode 19 = Run 20 = Ready 21 = STO 22 = No Fault 23 = With Fault 24 = No Alarm		64h	5Dh	A1h	USINT	9261	enum	1



Parameter	Description	Range of values	Decimal places	Class	Instance	Attribute	CIP data type	Net Id	Size	Qty mapped words
		25 = No Fault and Alarm 26 = Network 27 = SoftPLC 28 = Forward Direction 29 = Ride-Through 30 = Pre-Charge OK								
C5.8.4.22	DO8 Function	0 = Off 1 = On 2 = N* > Nx 3 = N > Nx 4 = N < Ny 5 = N = N* 6 ... 7 = Not used 8 = F > Fx 9 = Is > Ix 10 = Is < Ix 11 = Torque > Tx 12 = Torque < Tx 13 = Hours Enabled > Hx 14 ... 15 = Not used 16 = Local Mode 17 = Remote 1 Mode 18 = Remote 2 Mode 19 = Run 20 = Ready 21 = STO 22 = No Fault 23 = With Fault 24 = No Alarm 25 = No Fault and Alarm 26 = Network 27 = SoftPLC 28 = Forward Direction 29 = Ride-Through 30 = Pre-Charge OK		64h	5Dh	A2h	USINT	9262	enum	1
C5.8.5	Slot G-Encoder									
C5.8.5.1	Number of Pulses	1 to 65535 ppr	0	64h	5Dh	7Bh	UINT	9223	16bit	1
C5.8.5.2	Settings	Bit 0 = Broken Cable A Bit 2 = Broken Cable B Bit 4 = Broken Cable Z Bit 6 = Search Zero Bit 7 = Signal Direction		64h	5Dh	7Ch	WORD	9224	5bit	1
C5.8.6	Slot G-Temperatures									
C5.8.6.1	Sensor Type	0 = PT100 1 = PT1000 2 = Single PTC 3 = Triple PTC		64h	5Dh	92h	USINT	9246	enum	1



Parameter	Description	Range of values	Decimal places	Class	Instance	Attribute	CIP data type	Net Id	Size	Qty mapped words
C5.8.6.2	Overtemperature Config.	Bit 0 = S1 Sensor F/A Bit 2 = S2 Sensor F/A Bit 4 = S3 Sensor F/A Bit 6 = S4 Sensor F/A Bit 8 = S5 Sensor F/A Bit 10 = S6 Sensor F/A		64h	5Dh	93h	WORD	9247	6bit	1
C5.8.6.3	Broken Cable Config.	Bit 0 = S1 Sensor F/A Bit 2 = S2 Sensor F/A Bit 4 = S3 Sensor F/A Bit 6 = S4 Sensor F/A Bit 8 = S5 Sensor F/A Bit 10 = S6 Sensor F/A		64h	5Dh	94h	WORD	9248	6bit	1
C5.8.6.4	Temp. 1 Sensor Setpoint	-100.0 to 250.0 °C	1	64h	5Dh	95h	INT	9249	s16bit	1
C5.8.6.5	Temp. 2 Sensor Setpoint	-100.0 to 250.0 °C	1	64h	5Dh	96h	INT	9250	s16bit	1
C5.8.6.6	Temp. 3 Sensor Setpoint	-100.0 to 250.0 °C	1	64h	5Dh	97h	INT	9251	s16bit	1
C5.8.6.7	Temp. 4 Sensor Setpoint	-100.0 to 250.0 °C	1	64h	5Dh	98h	INT	9252	s16bit	1
C5.8.6.8	Temp. 5 Sensor Setpoint	-100.0 to 250.0 °C	1	64h	5Dh	99h	INT	9253	s16bit	1
C5.8.6.9	Temp. 6 Sensor Setpoint	-100.0 to 250.0 °C	1	64h	5Dh	9Ah	INT	9254	s16bit	1
C5.9	DO Operation Levels									
C5.9.1	Fx Frequency	0.0 to 300.0 Hz	1	64h	03h	B5h	UINT	281	16bit	1
C5.9.2	Fx Hysteresis	0.0 to 15.0 Hz	1	64h	03h	B6h	UINT	282	16bit	1
C5.9.3	Nx/Ny Hysteresis	0 to 900 rpm	0	64h	03h	BBh	UINT	287	16bit	1
C5.9.4	Nx Speed	0 to 18000 rpm	0	64h	03h	BCh	UINT	288	16bit	1
C5.9.5	Ny Speed	0 to 18000 rpm	0	64h	03h	BDh	UINT	289	16bit	1
C5.9.6	Ix Current	0.0 to 200.0 %	1	64h	03h	BEh	UINT	290	16bit	1
C5.9.8	N = N* Range	0 to 18000 rpm	0	64h	03h	C0h	UINT	292	16bit	1
C5.9.9	Torque Tx	0.0 to 200.0 %	1	64h	03h	C1h	UINT	293	16bit	1
C6 Configuration\Ramps										
C6.1	Speed Control Ramps									
C6.1.1	Acceleration Time	0.1 to 999.9 s	1	64h	02h	64h	UINT	100	16bit	1
C6.1.2	Deceleration Time	0.1 to 999.9 s	1	64h	02h	65h	UINT	101	16bit	1
C6.1.3	1st/2nd Ramp Selection	0 = 1st Ramp 1 = 2nd Ramp 2 = Serial 3 = Not used 4 = CAN/CO/DN 5 = SoftPLC 6 = Not used 7 = Ethernet 8 = DI Ramp Selection		64h	02h	69h	USINT	105	enum	1
C6.1.4	2nd Ramp Acceleration Time	0.1 to 999.9 s	1	64h	02h	66h	UINT	102	16bit	1
C6.1.5	2nd Ramp Deceleration Time	0.1 to 999.9 s	1	64h	02h	67h	UINT	103	16bit	1
C6.1.6	Quick Stop Time	0.1 to 999.9 s	1	64h	02h	6Ah	UINT	106	16bit	1
C6.1.7	Ramp Type	0 = Linear 1 = S Ramp		64h	02h	68h	USINT	104	enum	1
C6.2	Torque Control Ramps									



Parameter	Description	Range of values	Decimal places	Class	Instance	Attribute	CIP data type	Net Id	Size	Qty mapped words
C6.2.1	Increment Ramp	0.1 to 999.9 s	1	64h	29h	65h	UINT	4001	16bit	1
C6.2.2	Decrement Ramp	0.1 to 999.9 s	1	64h	29h	66h	UINT	4002	16bit	1
C7 Configuration\Protections										
C7.1	Power Supply Phase Loss									
C7.1.1	Min. Detection Time	0 to 60 s	0	64h	04h	9Dh	UINT	357	16bit	1
C7.1.2	Level Fine Setting	0.1 to 5.0	1	64h	04h	9Eh	UINT	358	16bit	1
C7.2	Ground Fault									
C7.2.1	Configuration	0 = Inactive 1 = Fault Enab.; Standard Level 2 = Fault Enab.; Extended Level		64h	15h	66h	USINT	2002	enum	1
C7.4	Motor Overload Fault									
C7.4.1	Enable Fault	0 = Disable 1 = Fault and Alarm 2 = Fault 3 = Alarm		64h	04h	94h	USINT	348	enum	1
C7.4.2	Alarm Level	10 to 100 %	0	64h	04h	95h	UINT	349	16bit	1
C7.4.3	Factor @ 100% Rat. Speed	0 to 200 %	0	64h	02h	9Ch	INT	156	s16bit	1
C7.4.4	Factor @ 50% Rat. Speed	0 to 200 %	0	64h	02h	9Dh	INT	157	s16bit	1
C7.4.5	Factor @ 5% Rat, Speed	0 to 200 %	0	64h	02h	9Eh	INT	158	s16bit	1
C7.4.6	Motor Thermal Class	0 = Class 5E 1 = Class 10E 2 = Class 15 3 = Class 20E 4 = Class 25 5 = Class 30E 6 = Class 35 7 = Class 40 8 = Class 45		64h	02h	9Fh	USINT	159	enum	1
C7.5	Over/Undertemp. Prot.									
C7.5.1	Configuration	Bit 0 = IGBT Overtemp. Bit 1 = Rectifier Overtemp. Bit 2 = Power Internal Air Overtemp. Bit 3 = Control Internal Air Overtemp. Bit 4 = Undertemperature		64h	04h	99h	WORD	353	5bit	1
C7.5.2	Motor Overtemp. Conf.	0 = Alarm and Fault 1 = Fault 2 = Alarm 3 = Disabled		64h	04h	97h	USINT	351	enum	1
C7.6	Fan Speed Fault									
C7.6.1	Power Fan Config.	0 = Alarm/Fault 1 = Alarm		64h	04h	9Ah	USINT	354	enum	1



Parameter	Description	Range of values	Decimal places	Class	Instance	Attribute	CIP data type	Net Id	Size	Qty mapped words
C7.6.2	Internal Fan Config.	0 = Alarm/Fault 1 = Alarm		64h	0Bh	9Ah	USINT	1054	enum	1
C7.7	Motor Overspeed									
C7.7.1	Maximum Overspeed Level	0.0 to 100.0 %	0	64h	02h	84h	REAL	132	TIME	2
C7.8	Pre-charge									
C7.8.1	Pre-charge Fault Settings	Bit 0 = Phase disconnected Bit 1 = Freq. out of range Bit 2 = Input Voltage Unbalance Bit 3 = Input Phase Unb.		64h	15h	6Ch	WORD	2008	4bit	1
C7.9	Auto-Reset									
C7.9.1	Time	0 to 3600 s	0	64h	04h	8Ch	UINT	340	16bit	1
C7.10	External Fault/Alarm									
C7.10.1	External Alarm DI	0 = Inactive 1 = DI X-1 2 = DI X-2 3 = DI X-3 4 = DI X-4 5 = DI X-5 6 = DI X-6 7 = DI A-1 8 = DI A-2 9 = DI A-3 10 = DI A-4 11 = DI A-5 12 = DI A-6 13 = DI A-7 14 = DI A-8 15 = DI B-1 16 = DI B-2 17 = DI B-3 18 = DI B-4 19 = DI B-5 20 = DI B-6 21 = DI B-7 22 = DI B-8 23 = DI C-1 24 = DI C-2 25 = DI C-3 26 = DI C-4 27 = DI C-5 28 = DI C-6 29 = DI C-7 30 = DI C-8 31 = DI D-1 32 = DI D-2 33 = DI D-3 34 = DI D-4		64h	3Dh	8Ah	USINT	6038	enum	1



Parameter	Description	Range of values	Decimal places	Class	Instance	Attribute	CIP data type	Net Id	Size	Qty mapped words	
		35 = DI D-5 36 = DI D-6 37 = DI D-7 38 = DI D-8 39 = DI E-1 40 = DI E-2 41 = DI E-3 42 = DI E-4 43 = DI E-5 44 = DI E-6 45 = DI E-7 46 = DI E-8 47 = DI F-1 48 = DI F-2 49 = DI F-3 50 = DI F-4 51 = DI F-5 52 = DI F-6 53 = DI F-7 54 = DI F-8 55 = DI G-1 56 = DI G-2 57 = DI G-3 58 = DI G-4 59 = DI G-5 60 = DI G-6 61 = DI G-7 62 = DI G-8									
C7.10.2	External Fault DI	0 = Inactive 1 = DI X-1 2 = DI X-2 3 = DI X-3 4 = DI X-4 5 = DI X-5 6 = DI X-6 7 = DI A-1 8 = DI A-2 9 = DI A-3 10 = DI A-4 11 = DI A-5 12 = DI A-6 13 = DI A-7 14 = DI A-8 15 = DI B-1 16 = DI B-2 17 = DI B-3 18 = DI B-4 19 = DI B-5 20 = DI B-6 21 = DI B-7		64h	3Dh	89h	USINT	6037	enum	1	



Parameter	Description	Range of values	Decimal places	Class	Instance	Attribute	CIP data type	Net Id	Size	Qty mapped words
		22 = DI B-8 23 = DI C-1 24 = DI C-2 25 = DI C-3 26 = DI C-4 27 = DI C-5 28 = DI C-6 29 = DI C-7 30 = DI C-8 31 = DI D-1 32 = DI D-2 33 = DI D-3 34 = DI D-4 35 = DI D-5 36 = DI D-6 37 = DI D-7 38 = DI D-8 39 = DI E-1 40 = DI E-2 41 = DI E-3 42 = DI E-4 43 = DI E-5 44 = DI E-6 45 = DI E-7 46 = DI E-8 47 = DI F-1 48 = DI F-2 49 = DI F-3 50 = DI F-4 51 = DI F-5 52 = DI F-6 53 = DI F-7 54 = DI F-8 55 = DI G-1 56 = DI G-2 57 = DI G-3 58 = DI G-4 59 = DI G-5 60 = DI G-6 61 = DI G-7 62 = DI G-8								
C7.11	Thermal Management									
C7.11.1	Jt, min IGBT Overload Fast Curve	-50 to 200 °C	0	64h	0Dh	66h	INT	1202	s16bit	1
C7.11.2	Temperature Regulator Config.	Bit 0 = Heatsink Temp. Reg. with fsw Operation Bit 1 = Junction Temperature Regulator Bit 2 = Heat sink Temp. Reg. w/ Power Fan Speed		64h	1Fh	89h	WORD	3037	3bit	1



Parameter	Description	Range of values	Decimal places	Class	Instance	Attribute	CIP data type	Net Id	Size	Qty mapped words
C7.11.7	Junction Temp. Regul. - Proport. Gain	0.00 to 20.00	2	64h	1Fh	8Bh	UINT	3039	16bit	1
C7.11.8	Junction Temp. Regul. - Integral Gain	0.00 to 20.00	2	64h	1Fh	A5h	UINT	3065	16bit	1
C7.11.9	NTC Temp. Regul. - Proport. Gain	0.00 to 20.00	2	64h	1Fh	B4h	UINT	3080	16bit	1
C7.11.10	NTC Temp. Regul. - Integral Gain	0.00 to 20.00	2	64h	1Fh	B5h	UINT	3081	16bit	1
C8 Configuration\Functional Safety										
C8.1	SS1-t Ramp Deceleration Time	0.1 to 999.9 s	1	64h	01h	C4h	UINT	96	16bit	1
C9 Configuration\Communications										
C9.1	Communication Errors									
C9.1.1	Master Offline									
C9.1.1.1	Mode	0 = Inactive 1 = Fault 2 = Alarm		64h	09h	C3h	USINT	895	enum	1
C9.1.1.2	Alarm Action	0 = Off 1 = Stop by Ramp 2 = General Disable 3 = Go to R1 4 = Go to R2		64h	09h	C4h	USINT	896	enum	1
C9.1.2	Master Idle/Prog									
C9.1.2.1	Mode	0 = Inactive 1 = Fault 2 = Alarm		64h	09h	C5h	USINT	897	enum	1
C9.1.2.2	Action Alarm	0 = Off 1 = Stop by Ramp 2 = General Disable 3 = Go to R1 4 = Go to R2		64h	09h	C6h	USINT	898	enum	1
C9.2	I/O Data									
C9.2.1	Reading Data									
C9.2.1.1	Word #1	0 to 9999	0	64h	0Eh	64h	INT	1300	s16bit	1
C9.2.1.2	Word #2	0 to 9999	0	64h	0Eh	65h	INT	1301	s16bit	1
C9.2.1.3	Word #3	0 to 9999	0	64h	0Eh	66h	INT	1302	s16bit	1
C9.2.1.4	Word #4	0 to 9999	0	64h	0Eh	67h	INT	1303	s16bit	1
C9.2.1.5	Word #5	0 to 9999	0	64h	0Eh	68h	INT	1304	s16bit	1
C9.2.1.6	Word #6	0 to 9999	0	64h	0Eh	69h	INT	1305	s16bit	1
C9.2.1.7	Word #7	0 to 9999	0	64h	0Eh	6Ah	INT	1306	s16bit	1
C9.2.1.8	Word #8	0 to 9999	0	64h	0Eh	6Bh	INT	1307	s16bit	1
C9.2.1.9	Word #9	0 to 9999	0	64h	0Eh	6Ch	INT	1308	s16bit	1
C9.2.1.10	Word #10	0 to 9999	0	64h	0Eh	6Dh	INT	1309	s16bit	1
C9.2.1.11	Word #11	0 to 9999	0	64h	0Eh	6Eh	INT	1310	s16bit	1
C9.2.1.12	Word #12	0 to 9999	0	64h	0Eh	6Fh	INT	1311	s16bit	1
C9.2.1.13	Word #13	0 to 9999	0	64h	0Eh	70h	INT	1312	s16bit	1
C9.2.1.14	Word #14	0 to 9999	0	64h	0Eh	71h	INT	1313	s16bit	1
C9.2.1.15	Word #15	0 to 9999	0	64h	0Eh	72h	INT	1314	s16bit	1



Parameter	Description	Range of values	Decimal places	Class	Instance	Attribute	CIP data type	Net Id	Size	Qty mapped words
C9.2.1.16	Word #16	0 to 9999	0	64h	0Eh	73h	INT	1315	s16bit	1
C9.2.1.17	Word #17	0 to 9999	0	64h	0Eh	74h	INT	1316	s16bit	1
C9.2.1.18	Word #18	0 to 9999	0	64h	0Eh	75h	INT	1317	s16bit	1
C9.2.1.19	Word #19	0 to 9999	0	64h	0Eh	76h	INT	1318	s16bit	1
C9.2.1.20	Word #20	0 to 9999	0	64h	0Eh	77h	INT	1319	s16bit	1
C9.2.1.21	Word #21	0 to 9999	0	64h	0Eh	78h	INT	1320	s16bit	1
C9.2.1.22	Word #22	0 to 9999	0	64h	0Eh	79h	INT	1321	s16bit	1
C9.2.1.23	Word #23	0 to 9999	0	64h	0Eh	7Ah	INT	1322	s16bit	1
C9.2.1.24	Word #24	0 to 9999	0	64h	0Eh	7Bh	INT	1323	s16bit	1
C9.2.1.25	Word #25	0 to 9999	0	64h	0Eh	7Ch	INT	1324	s16bit	1
C9.2.1.26	Word #26	0 to 9999	0	64h	0Eh	7Dh	INT	1325	s16bit	1
C9.2.1.27	Word #27	0 to 9999	0	64h	0Eh	7Eh	INT	1326	s16bit	1
C9.2.1.28	Word #28	0 to 9999	0	64h	0Eh	7Fh	INT	1327	s16bit	1
C9.2.1.29	Word #29	0 to 9999	0	64h	0Eh	80h	INT	1328	s16bit	1
C9.2.1.30	Word #30	0 to 9999	0	64h	0Eh	81h	INT	1329	s16bit	1
C9.2.1.31	Word #31	0 to 9999	0	64h	0Eh	82h	INT	1330	s16bit	1
C9.2.1.32	Word #32	0 to 9999	0	64h	0Eh	83h	INT	1331	s16bit	1
C9.2.1.33	Word #33	0 to 9999	0	64h	0Eh	84h	INT	1332	s16bit	1
C9.2.1.34	Word #34	0 to 9999	0	64h	0Eh	85h	INT	1333	s16bit	1
C9.2.1.35	Word #35	0 to 9999	0	64h	0Eh	86h	INT	1334	s16bit	1
C9.2.1.36	Word #36	0 to 9999	0	64h	0Eh	87h	INT	1335	s16bit	1
C9.2.1.37	Word #37	0 to 9999	0	64h	0Eh	88h	INT	1336	s16bit	1
C9.2.1.38	Word #38	0 to 9999	0	64h	0Eh	89h	INT	1337	s16bit	1
C9.2.1.39	Word #39	0 to 9999	0	64h	0Eh	8Ah	INT	1338	s16bit	1
C9.2.1.40	Word #40	0 to 9999	0	64h	0Eh	8Bh	INT	1339	s16bit	1
C9.2.1.41	Word #41	0 to 9999	0	64h	0Eh	8Ch	INT	1340	s16bit	1
C9.2.1.42	Word #42	0 to 9999	0	64h	0Eh	8Dh	INT	1341	s16bit	1
C9.2.1.43	Word #43	0 to 9999	0	64h	0Eh	8Eh	INT	1342	s16bit	1
C9.2.1.44	Word #44	0 to 9999	0	64h	0Eh	8Fh	INT	1343	s16bit	1
C9.2.1.45	Word #45	0 to 9999	0	64h	0Eh	90h	INT	1344	s16bit	1
C9.2.1.46	Word #46	0 to 9999	0	64h	0Eh	91h	INT	1345	s16bit	1
C9.2.1.47	Word #47	0 to 9999	0	64h	0Eh	92h	INT	1346	s16bit	1
C9.2.1.48	Word #48	0 to 9999	0	64h	0Eh	93h	INT	1347	s16bit	1
C9.2.1.49	Word #49	0 to 9999	0	64h	0Eh	94h	INT	1348	s16bit	1
C9.2.1.50	Word #50	0 to 9999	0	64h	0Eh	95h	INT	1349	s16bit	1
C9.2.1.51	Word #51	0 to 9999	0	64h	0Eh	96h	INT	1350	s16bit	1
C9.2.1.52	Word #52	0 to 9999	0	64h	0Eh	97h	INT	1351	s16bit	1
C9.2.1.53	Word #53	0 to 9999	0	64h	0Eh	98h	INT	1352	s16bit	1
C9.2.1.54	Word #54	0 to 9999	0	64h	0Eh	99h	INT	1353	s16bit	1
C9.2.1.55	Word #55	0 to 9999	0	64h	0Eh	9Ah	INT	1354	s16bit	1
C9.2.1.56	Word #56	0 to 9999	0	64h	0Eh	9Bh	INT	1355	s16bit	1
C9.2.1.57	Word #57	0 to 9999	0	64h	0Eh	9Ch	INT	1356	s16bit	1
C9.2.1.58	Word #58	0 to 9999	0	64h	0Eh	9Dh	INT	1357	s16bit	1
C9.2.1.59	Word #59	0 to 9999	0	64h	0Eh	9Eh	INT	1358	s16bit	1
C9.2.1.60	Word #60	0 to 9999	0	64h	0Eh	9Fh	INT	1359	s16bit	1
C9.2.1.61	Word #61	0 to 9999	0	64h	0Eh	A0h	INT	1360	s16bit	1
C9.2.1.62	Word #62	0 to 9999	0	64h	0Eh	A1h	INT	1361	s16bit	1
C9.2.1.63	Word #63	0 to 9999	0	64h	0Eh	A2h	INT	1362	s16bit	1
C9.2.1.64	Word #64	0 to 9999	0	64h	0Eh	A3h	INT	1363	s16bit	1
C9.2.1.65	Word #65	0 to 9999	0	64h	0Eh	A4h	INT	1364	s16bit	1
C9.2.1.66	Word #66	0 to 9999	0	64h	0Eh	A5h	INT	1365	s16bit	1



Parameter	Description	Range of values	Decimal places	Class	Instance	Attribute	CIP data type	Net Id	Size	Qty mapped words
C9.2.1.67	Word #67	0 to 9999	0	64h	0Eh	A6h	INT	1366	s16bit	1
C9.2.1.68	Word #68	0 to 9999	0	64h	0Eh	A7h	INT	1367	s16bit	1
C9.2.1.69	Word #69	0 to 9999	0	64h	0Eh	A8h	INT	1368	s16bit	1
C9.2.1.70	Word #70	0 to 9999	0	64h	0Eh	A9h	INT	1369	s16bit	1
C9.2.1.71	Word #71	0 to 9999	0	64h	0Eh	AAh	INT	1370	s16bit	1
C9.2.1.72	Word #72	0 to 9999	0	64h	0Eh	ABh	INT	1371	s16bit	1
C9.2.1.73	Word #73	0 to 9999	0	64h	0Eh	ACh	INT	1372	s16bit	1
C9.2.1.74	Word #74	0 to 9999	0	64h	0Eh	ADh	INT	1373	s16bit	1
C9.2.1.75	Word #75	0 to 9999	0	64h	0Eh	A Eh	INT	1374	s16bit	1
C9.2.1.76	Word #76	0 to 9999	0	64h	0Eh	AFh	INT	1375	s16bit	1
C9.2.1.77	Word #77	0 to 9999	0	64h	0Eh	B0h	INT	1376	s16bit	1
C9.2.1.78	Word #78	0 to 9999	0	64h	0Eh	B1h	INT	1377	s16bit	1
C9.2.1.79	Word #79	0 to 9999	0	64h	0Eh	B2h	INT	1378	s16bit	1
C9.2.1.80	Word #80	0 to 9999	0	64h	0Eh	B3h	INT	1379	s16bit	1
C9.2.1.81	Word #81	0 to 9999	0	64h	0Eh	B4h	INT	1380	s16bit	1
C9.2.1.82	Word #82	0 to 9999	0	64h	0Eh	B5h	INT	1381	s16bit	1
C9.2.1.83	Word #83	0 to 9999	0	64h	0Eh	B6h	INT	1382	s16bit	1
C9.2.1.84	Word #84	0 to 9999	0	64h	0Eh	B7h	INT	1383	s16bit	1
C9.2.1.85	Word #85	0 to 9999	0	64h	0Eh	B8h	INT	1384	s16bit	1
C9.2.1.86	Word #86	0 to 9999	0	64h	0Eh	B9h	INT	1385	s16bit	1
C9.2.1.87	Word #87	0 to 9999	0	64h	0Eh	BAh	INT	1386	s16bit	1
C9.2.1.88	Word #88	0 to 9999	0	64h	0Eh	BBh	INT	1387	s16bit	1
C9.2.1.89	Word #89	0 to 9999	0	64h	0Eh	BCh	INT	1388	s16bit	1
C9.2.1.90	Word #90	0 to 9999	0	64h	0Eh	BDh	INT	1389	s16bit	1
C9.2.1.91	Word #91	0 to 9999	0	64h	0Eh	BEh	INT	1390	s16bit	1
C9.2.1.92	Word #92	0 to 9999	0	64h	0Eh	BFh	INT	1391	s16bit	1
C9.2.1.93	Word #93	0 to 9999	0	64h	0Eh	C0h	INT	1392	s16bit	1
C9.2.1.94	Word #94	0 to 9999	0	64h	0Eh	C1h	INT	1393	s16bit	1
C9.2.1.95	Word #95	0 to 9999	0	64h	0Eh	C2h	INT	1394	s16bit	1
C9.2.1.96	Word #96	0 to 9999	0	64h	0Eh	C3h	INT	1395	s16bit	1
C9.2.1.97	Word #97	0 to 9999	0	64h	0Eh	C4h	INT	1396	s16bit	1
C9.2.1.98	Word #98	0 to 9999	0	64h	0Eh	C5h	INT	1397	s16bit	1
C9.2.1.99	Word #99	0 to 9999	0	64h	0Eh	C6h	INT	1398	s16bit	1
C9.2.1.100	Word #100	0 to 9999	0	64h	0Eh	C7h	INT	1399	s16bit	1
C9.2.2	Writing Data									
C9.2.2.1	Update Delay	0.0 to 999.0 s	1	64h	09h	C7h	UINT	899	16bit	1
C9.2.2.2	Word #1	0 to 9999	0	64h	0Fh	64h	INT	1400	s16bit	1
C9.2.2.3	Word #2	0 to 9999	0	64h	0Fh	65h	INT	1401	s16bit	1
C9.2.2.4	Word #3	0 to 9999	0	64h	0Fh	66h	INT	1402	s16bit	1
C9.2.2.5	Word #4	0 to 9999	0	64h	0Fh	67h	INT	1403	s16bit	1
C9.2.2.6	Word #5	0 to 9999	0	64h	0Fh	68h	INT	1404	s16bit	1
C9.2.2.7	Word #6	0 to 9999	0	64h	0Fh	69h	INT	1405	s16bit	1
C9.2.2.8	Word #7	0 to 9999	0	64h	0Fh	6Ah	INT	1406	s16bit	1
C9.2.2.9	Word #8	0 to 9999	0	64h	0Fh	6Bh	INT	1407	s16bit	1
C9.2.2.10	Word #9	0 to 9999	0	64h	0Fh	6Ch	INT	1408	s16bit	1
C9.2.2.11	Word #10	0 to 9999	0	64h	0Fh	6Dh	INT	1409	s16bit	1
C9.2.2.12	Word #11	0 to 9999	0	64h	0Fh	6Eh	INT	1410	s16bit	1
C9.2.2.13	Word #12	0 to 9999	0	64h	0Fh	6Fh	INT	1411	s16bit	1
C9.2.2.14	Word #13	0 to 9999	0	64h	0Fh	70h	INT	1412	s16bit	1
C9.2.2.15	Word #14	0 to 9999	0	64h	0Fh	71h	INT	1413	s16bit	1
C9.2.2.16	Word #15	0 to 9999	0	64h	0Fh	72h	INT	1414	s16bit	1



Parameter	Description	Range of values	Decimal places	Class	Instance	Attribute	CIP data type	Net Id	Size	Qty mapped words
C9.2.2.17	Word #16	0 to 9999	0	64h	0Fh	73h	INT	1415	s16bit	1
C9.2.2.18	Word #17	0 to 9999	0	64h	0Fh	74h	INT	1416	s16bit	1
C9.2.2.19	Word #18	0 to 9999	0	64h	0Fh	75h	INT	1417	s16bit	1
C9.2.2.20	Word #19	0 to 9999	0	64h	0Fh	76h	INT	1418	s16bit	1
C9.2.2.21	Word #20	0 to 9999	0	64h	0Fh	77h	INT	1419	s16bit	1
C9.2.2.22	Word #21	0 to 9999	0	64h	0Fh	78h	INT	1420	s16bit	1
C9.2.2.23	Word #22	0 to 9999	0	64h	0Fh	79h	INT	1421	s16bit	1
C9.2.2.24	Word #23	0 to 9999	0	64h	0Fh	7Ah	INT	1422	s16bit	1
C9.2.2.25	Word #24	0 to 9999	0	64h	0Fh	7Bh	INT	1423	s16bit	1
C9.2.2.26	Word #25	0 to 9999	0	64h	0Fh	7Ch	INT	1424	s16bit	1
C9.2.2.27	Word #26	0 to 9999	0	64h	0Fh	7Dh	INT	1425	s16bit	1
C9.2.2.28	Word #27	0 to 9999	0	64h	0Fh	7Eh	INT	1426	s16bit	1
C9.2.2.29	Word #28	0 to 9999	0	64h	0Fh	7Fh	INT	1427	s16bit	1
C9.2.2.30	Word #29	0 to 9999	0	64h	0Fh	80h	INT	1428	s16bit	1
C9.2.2.31	Word #30	0 to 9999	0	64h	0Fh	81h	INT	1429	s16bit	1
C9.2.2.32	Word #31	0 to 9999	0	64h	0Fh	82h	INT	1430	s16bit	1
C9.2.2.33	Word #32	0 to 9999	0	64h	0Fh	83h	INT	1431	s16bit	1
C9.2.2.34	Word #33	0 to 9999	0	64h	0Fh	84h	INT	1432	s16bit	1
C9.2.2.35	Word #34	0 to 9999	0	64h	0Fh	85h	INT	1433	s16bit	1
C9.2.2.36	Word #35	0 to 9999	0	64h	0Fh	86h	INT	1434	s16bit	1
C9.2.2.37	Word #36	0 to 9999	0	64h	0Fh	87h	INT	1435	s16bit	1
C9.2.2.38	Word #37	0 to 9999	0	64h	0Fh	88h	INT	1436	s16bit	1
C9.2.2.39	Word #38	0 to 9999	0	64h	0Fh	89h	INT	1437	s16bit	1
C9.2.2.40	Word #39	0 to 9999	0	64h	0Fh	8Ah	INT	1438	s16bit	1
C9.2.2.41	Word #40	0 to 9999	0	64h	0Fh	8Bh	INT	1439	s16bit	1
C9.2.2.42	Word #41	0 to 9999	0	64h	0Fh	8Ch	INT	1440	s16bit	1
C9.2.2.43	Word #42	0 to 9999	0	64h	0Fh	8Dh	INT	1441	s16bit	1
C9.2.2.44	Word #43	0 to 9999	0	64h	0Fh	8Eh	INT	1442	s16bit	1
C9.2.2.45	Word #44	0 to 9999	0	64h	0Fh	8Fh	INT	1443	s16bit	1
C9.2.2.46	Word #45	0 to 9999	0	64h	0Fh	90h	INT	1444	s16bit	1
C9.2.2.47	Word #46	0 to 9999	0	64h	0Fh	91h	INT	1445	s16bit	1
C9.2.2.48	Word #47	0 to 9999	0	64h	0Fh	92h	INT	1446	s16bit	1
C9.2.2.49	Word #48	0 to 9999	0	64h	0Fh	93h	INT	1447	s16bit	1
C9.2.2.50	Word #49	0 to 9999	0	64h	0Fh	94h	INT	1448	s16bit	1
C9.2.2.51	Word #50	0 to 9999	0	64h	0Fh	95h	INT	1449	s16bit	1
C9.2.2.52	Word #51	0 to 9999	0	64h	0Fh	96h	INT	1450	s16bit	1
C9.2.2.53	Word #52	0 to 9999	0	64h	0Fh	97h	INT	1451	s16bit	1
C9.2.2.54	Word #53	0 to 9999	0	64h	0Fh	98h	INT	1452	s16bit	1
C9.2.2.55	Word #54	0 to 9999	0	64h	0Fh	99h	INT	1453	s16bit	1
C9.2.2.56	Word #55	0 to 9999	0	64h	0Fh	9Ah	INT	1454	s16bit	1
C9.2.2.57	Word #56	0 to 9999	0	64h	0Fh	9Bh	INT	1455	s16bit	1
C9.2.2.58	Word #57	0 to 9999	0	64h	0Fh	9Ch	INT	1456	s16bit	1
C9.2.2.59	Word #58	0 to 9999	0	64h	0Fh	9Dh	INT	1457	s16bit	1
C9.2.2.60	Word #59	0 to 9999	0	64h	0Fh	9Eh	INT	1458	s16bit	1
C9.2.2.61	Word #60	0 to 9999	0	64h	0Fh	9Fh	INT	1459	s16bit	1
C9.2.2.62	Word #61	0 to 9999	0	64h	0Fh	A0h	INT	1460	s16bit	1
C9.2.2.63	Word #62	0 to 9999	0	64h	0Fh	A1h	INT	1461	s16bit	1
C9.2.2.64	Word #63	0 to 9999	0	64h	0Fh	A2h	INT	1462	s16bit	1
C9.2.2.65	Word #64	0 to 9999	0	64h	0Fh	A3h	INT	1463	s16bit	1
C9.2.2.66	Word #65	0 to 9999	0	64h	0Fh	A4h	INT	1464	s16bit	1
C9.2.2.67	Word #66	0 to 9999	0	64h	0Fh	A5h	INT	1465	s16bit	1



Parameter	Description	Range of values	Decimal places	Class	Instance	Attribute	CIP data type	Net Id	Size	Qty mapped words
C9.2.2.68	Word #67	0 to 9999	0	64h	0Fh	A6h	INT	1466	s16bit	1
C9.2.2.69	Word #68	0 to 9999	0	64h	0Fh	A7h	INT	1467	s16bit	1
C9.2.2.70	Word #69	0 to 9999	0	64h	0Fh	A8h	INT	1468	s16bit	1
C9.2.2.71	Word #70	0 to 9999	0	64h	0Fh	A9h	INT	1469	s16bit	1
C9.2.2.72	Word #71	0 to 9999	0	64h	0Fh	AAh	INT	1470	s16bit	1
C9.2.2.73	Word #72	0 to 9999	0	64h	0Fh	ABh	INT	1471	s16bit	1
C9.2.2.74	Word #73	0 to 9999	0	64h	0Fh	ACh	INT	1472	s16bit	1
C9.2.2.75	Word #74	0 to 9999	0	64h	0Fh	ADh	INT	1473	s16bit	1
C9.2.2.76	Word #75	0 to 9999	0	64h	0Fh	A Eh	INT	1474	s16bit	1
C9.2.2.77	Word #76	0 to 9999	0	64h	0Fh	AFh	INT	1475	s16bit	1
C9.2.2.78	Word #77	0 to 9999	0	64h	0Fh	B0h	INT	1476	s16bit	1
C9.2.2.79	Word #78	0 to 9999	0	64h	0Fh	B1h	INT	1477	s16bit	1
C9.2.2.80	Word #79	0 to 9999	0	64h	0Fh	B2h	INT	1478	s16bit	1
C9.2.2.81	Word #80	0 to 9999	0	64h	0Fh	B3h	INT	1479	s16bit	1
C9.2.2.82	Word #81	0 to 9999	0	64h	0Fh	B4h	INT	1480	s16bit	1
C9.2.2.83	Word #82	0 to 9999	0	64h	0Fh	B5h	INT	1481	s16bit	1
C9.2.2.84	Word #83	0 to 9999	0	64h	0Fh	B6h	INT	1482	s16bit	1
C9.2.2.85	Word #84	0 to 9999	0	64h	0Fh	B7h	INT	1483	s16bit	1
C9.2.2.86	Word #85	0 to 9999	0	64h	0Fh	B8h	INT	1484	s16bit	1
C9.2.2.87	Word #86	0 to 9999	0	64h	0Fh	B9h	INT	1485	s16bit	1
C9.2.2.88	Word #87	0 to 9999	0	64h	0Fh	BAh	INT	1486	s16bit	1
C9.2.2.89	Word #88	0 to 9999	0	64h	0Fh	BBh	INT	1487	s16bit	1
C9.2.2.90	Word #89	0 to 9999	0	64h	0Fh	BCh	INT	1488	s16bit	1
C9.2.2.91	Word #90	0 to 9999	0	64h	0Fh	BDh	INT	1489	s16bit	1
C9.2.2.92	Word #91	0 to 9999	0	64h	0Fh	BEh	INT	1490	s16bit	1
C9.2.2.93	Word #92	0 to 9999	0	64h	0Fh	BFh	INT	1491	s16bit	1
C9.2.2.94	Word #93	0 to 9999	0	64h	0Fh	C0h	INT	1492	s16bit	1
C9.2.2.95	Word #94	0 to 9999	0	64h	0Fh	C1h	INT	1493	s16bit	1
C9.2.2.96	Word #95	0 to 9999	0	64h	0Fh	C2h	INT	1494	s16bit	1
C9.2.2.97	Word #96	0 to 9999	0	64h	0Fh	C3h	INT	1495	s16bit	1
C9.2.2.98	Word #97	0 to 9999	0	64h	0Fh	C4h	INT	1496	s16bit	1
C9.2.2.99	Word #98	0 to 9999	0	64h	0Fh	C5h	INT	1497	s16bit	1
C9.2.2.100	Word #99	0 to 9999	0	64h	0Fh	C6h	INT	1498	s16bit	1
C9.2.2.101	Word #100	0 to 9999	0	64h	0Fh	C7h	INT	1499	s16bit	1
C9.3	Serial RS485									
C9.3.1	Protocol	0 ... 1 = Reserved 2 = Modbus RTU		64h	08h	82h	USINT	730	enum	1
C9.3.2	Address	1 to 247	0	64h	08h	83h	USINT	731	8bit	1
C9.3.3	Baud Rate	0 = 9600 bit/s 1 = 19200 bit/s 2 = 38400 bit/s 3 = 57600 bit/s		64h	08h	84h	USINT	732	enum	1
C9.3.4	Bytes Config.	0 = 8-bits, no, 1 1 = 8-bits, even,1 2 = 8-bits, odd, 1 3 = 8-bits, no, 2 4 = 8-bits, even,2		64h	08h	85h	USINT	733	enum	1



Parameter	Description	Range of values	Decimal places	Class	Instance	Attribute	CIP data type	Net Id	Size	Qty mapped words
C9.3.5	RS485 Timeout	5 = 8-bits, odd, 2 0.0 to 999.0 s	1	64h	08h	86h	UINT	734	16bit	1
C9.4	Ethernet									
C9.4.1	IP Address Configuration	0 = Parameters 1 = DHCP		64h	09h	96h	USINT	850	enum	1
C9.4.2	IP Address	0.0.0.0 to 255.255.255.255		64h	09h	98h	UDINT	852	STRING	2
C9.4.3	Network Mask	0 = Reserved 1 = 128.0.0.0 2 = 192.0.0.0 3 = 224.0.0.0 4 = 240.0.0.0 5 = 248.0.0.0 6 = 252.0.0.0 7 = 254.0.0.0 8 = 255.0.0.0 9 = 255.128.0.0 10 = 255.192.0.0 11 = 255.224.0.0 12 = 255.240.0.0 13 = 255.248.0.0 14 = 255.252.0.0 15 = 255.254.0.0 16 = 255.255.0.0 17 = 255.255.128.0 18 = 255.255.192.0 19 = 255.255.224.0 20 = 255.255.240.0 21 = 255.255.248.0 22 = 255.255.252.0 23 = 255.255.254.0 24 = 255.255.255.0 25 = 255.255.255.128 26 = 255.255.255.192 27 = 255.255.255.224 28 = 255.255.255.240 29 = 255.255.255.248 30 = 255.255.255.252 31 = 255.255.255.254		64h	09h	9Bh	USINT	855	enum	1
C9.4.4	Gateway	0.0.0.0 to 255.255.255.255		64h	09h	9Ch	UDINT	856	STRING	2
C9.4.5	SNTP - Server 1	0.0.0.0 to 255.255.255.255		64h	08h	AAh	UDINT	770	STRING	2
C9.4.6	SNTP - Server 2	0.0.0.0 to 255.255.255.255		64h	08h	AEh	UDINT	774	STRING	2
C9.4.7	SNTP - Update	0 to 65535	0	64h	08h	B3h	UINT	779	16bit	1
C9.5	EtherNet/IP									
C9.5.1	EtherNet/IP I/O Instances	0 = 20/70 CIP 1 = 21/71 CIP 2 ... 3 = Not used 4 = 120/170 CIP + I/O data		64h	09h	ABh	USINT	871	enum	1



Parameter	Description	Range of values	Decimal places	Class	Instance	Attribute	CIP data type	Net Id	Size	Qty mapped words
		5 = 121/171 CIP + I/O data 6 ... 7 = Not used 8 = 100/150 Manuf. + I/O data 9 = 101/151 Manuf. + I/O data 10 = 102/152 Config I/O data								
C9.5.2	Reading 1st Word	1 to 100	0	64h	09h	ACh	INT	872	s16bit	1
C9.5.3	Reading Quantity	0 to 50	0	64h	09h	ADh	INT	873	s16bit	1
C9.5.4	Writing 1st Word	1 to 100	0	64h	09h	A Eh	INT	874	s16bit	1
C9.5.5	Writing Quantity	0 to 50	0	64h	09h	AFh	INT	875	s16bit	1
C9.6	Modbus TCP									
C9.6.1	TCP Port	0 to 65535	0	64h	09h	A5h	UINT	865	16bit	1
C9.6.3	Timeout	0.0 to 999.0 s	1	64h	09h	A8h	UINT	868	16bit	1
C9.8	CAN/CANopen/DNet									
C9.8.1	Protocol	0 = Disabled 1 = CANopen 2 = DeviceNet		64h	08h	64h	USINT	700	enum	1
C9.8.2	Address	0 to 127	0	64h	08h	65h	UINT	701	16bit	1
C9.8.3	Baud Rate	0 = 1 Mbps/Auto 1 = Reserved/Auto 2 = 500 Kbps 3 = 250 Kbps 4 = 125 Kbps 5 = 100 Kbps/Auto		64h	08h	66h	USINT	702	enum	1
C9.8.4	Bus Off Reset	0 = Manual 1 = Automatic		64h	08h	67h	USINT	703	enum	1
C9.8.5	DeviceNet I/O Instances	0 = 20/70 CIP 1 = 21/71 CIP 2 ... 3 = Not used 4 = 120/170 CIP + I/O data 5 = 121/171 CIP + I/O data 6 ... 7 = Not used 8 = 100/150 Manuf. + I/O data 9 = 101/151 Manuf. + I/O data 10 = 102/152 Config I/O data		64h	08h	6Eh	USINT	710	enum	1
C9.8.6	DNet Reading 1st Word	1 to 100	0	64h	08h	70h	INT	712	s16bit	1
C9.8.7	DNet Reading Quantity	0 to 50	0	64h	08h	71h	INT	713	s16bit	1
C9.8.8	DNet Writing 1st Word	1 to 100	0	64h	08h	72h	INT	714	s16bit	1
C9.8.9	DNet Writing Quantity	0 to 50	0	64h	08h	73h	INT	715	s16bit	1
C9.10	Bluetooth									
C9.10.1	Mode	0 = Inactive 1 = Active		64h	09h	64h	USINT	800	enum	1
C9.11	SymbiNet									
C9.11.1	Enable Protocol	0 = Disable		64h	0Bh	A0h	USINT	1060	enum	1



Parameter	Description	Range of values	Decimal places	Class	Instance	Attribute	CIP data type	Net Id	Size	Qty mapped words
C9.11.2	Publication Time	1 = Enable 2 to 100 ms	0	64h	0Bh	A1h	UINT	1061	16bit	1
C9.11.3	Grp1: Source Addr.	0 to 254	0	64h	0Bh	A8h	UINT	1068	16bit	1
C9.11.4	Grp1: Source Reg.	0 to 65535	0	64h	0Bh	A9h	UINT	1069	16bit	1
C9.11.5	Grp1: Dest. Reg.	0 to 65535	0	64h	0Bh	AAh	UINT	1070	16bit	1
C9.11.6	Grp1: Num. of Registers	0 to 8	0	64h	0Bh	ABh	UINT	1071	16bit	1
C9.11.7	Grp2: Source Addr.	0 to 254	0	64h	0Bh	ACh	UINT	1072	16bit	1
C9.11.8	Grp2: Source Reg.	0 to 65535	0	64h	0Bh	ADh	UINT	1073	16bit	1
C9.11.9	Grp2: Dest. Reg.	0 to 65535	0	64h	0Bh	AEh	UINT	1074	16bit	1
C9.11.10	Grp2: Num. of Registers	0 to 8	0	64h	0Bh	AFh	UINT	1075	16bit	1
C9.11.11	Grp3: Source Addr.	0 to 254	0	64h	0Bh	B0h	UINT	1076	16bit	1
C9.11.12	Grp3: Source Reg.	0 to 65535	0	64h	0Bh	B1h	UINT	1077	16bit	1
C9.11.13	Grp3: Dest. Reg.	0 to 65535	0	64h	0Bh	B2h	UINT	1078	16bit	1
C9.11.14	Grp3: Num. of Registers	0 to 8	0	64h	0Bh	B3h	UINT	1079	16bit	1
C9.11.15	Grp4: Source Addr.	0 to 254	0	64h	0Bh	B4h	UINT	1080	16bit	1
C9.11.16	Grp4: Source Reg.	0 to 65535	0	64h	0Bh	B5h	UINT	1081	16bit	1
C9.11.17	Grp4: Dest. Reg.	0 to 65535	0	64h	0Bh	B6h	UINT	1082	16bit	1
C9.11.18	Grp4: Num. of Registers	0 to 8	0	64h	0Bh	B7h	UINT	1083	16bit	1
C9.11.19	Grp5: Source Addr.	0 to 254	0	64h	0Bh	B8h	UINT	1084	16bit	1
C9.11.20	Grp5: Source Reg.	0 to 65535	0	64h	0Bh	B9h	UINT	1085	16bit	1
C9.11.21	Grp5: Dest. Reg.	0 to 65535	0	64h	0Bh	BAh	UINT	1086	16bit	1
C9.11.22	Grp5: Num. of Registers	0 to 8	0	64h	0Bh	BBh	UINT	1087	16bit	1
C9.11.23	Grp6: Source Addr.	0 to 254	0	64h	0Bh	BCh	UINT	1088	16bit	1
C9.11.24	Grp6: Source Reg.	0 to 65535	0	64h	0Bh	BDh	UINT	1089	16bit	1
C9.11.25	Grp6: Dest. Reg.	0 to 65535	0	64h	0Bh	BEh	UINT	1090	16bit	1
C9.11.26	Grp6: Num. of Registers	0 to 8	0	64h	0Bh	BFh	UINT	1091	16bit	1
C9.11.27	Grp7: Source Addr.	0 to 254	0	64h	0Bh	C0h	UINT	1092	16bit	1
C9.11.28	Grp7: Source Reg.	0 to 65535	0	64h	0Bh	C1h	UINT	1093	16bit	1
C9.11.29	Grp7: Dest. Reg.	0 to 65535	0	64h	0Bh	C2h	UINT	1094	16bit	1
C9.11.30	Grp7: Num. of Registers	0 to 8	0	64h	0Bh	C3h	UINT	1095	16bit	1
C9.11.31	Grp8: Source Addr.	0 to 254	0	64h	0Bh	C4h	UINT	1096	16bit	1
C9.11.32	Grp8: Source Reg.	0 to 65535	0	64h	0Bh	C5h	UINT	1097	16bit	1
C9.11.33	Grp8: Dest. Reg.	0 to 65535	0	64h	0Bh	C6h	UINT	1098	16bit	1
C9.11.34	Grp8: Num. of Registers	0 to 8	0	64h	0Bh	C7h	UINT	1099	16bit	1
C10 Configuration/SoftPLC										
C10.1	Configuration									
C10.1.1	Command	0 = Stop 1 = Run 2 ... 4 = Not Used 5 = Erase		64h	34h	64h	USINT	5100	enum	1
C10.1.2	Active Application	0 = User Application 1 1 = User Application 2 2 ... 6 = Not used		64h	34h	65h	USINT	5101	enum	1
C10.1.3	Action Application Stopped	0 = Inactive 1 = Generate Alarm 2 = Trip Fault		64h	34h	66h	USINT	5102	enum	1
C10.2	Engineering Unit									



Parameter	Description	Range of values	Decimal places	Class	Instance	Attribute	CIP data type	Net Id	Size	Qty mapped words
C10.2.1	Engineering Unit 1	0 = No Unit 1 = A 2 = bar 3 = °C 4 = CPM 5 = CV 6 = ft³ 7 = ft³/h 8 = ft³/min 9 = ft³/s 10 = m³ 11 = m³/h 12 = m³/min 13 = m³/s 14 = °F 15 = ft 16 = ft/h 17 = ft/min 18 = ft/s 19 = gal 20 = gal/h 21 = gal/min 22 = gal/s 23 = H 24 = Hz 25 = HP 26 = h 27 = in 28 = InWC 29 = K 30 = kg 31 = kgf 32 = kgf/cm² 33 = kgf/m² 34 = kl/h 35 = kPa 36 = kW 37 = kWh 38 = l 39 = l/h 40 = l/min 41 = l/s 42 = lbf 43 = mA 44 = mca 45 = m 46 = m/h 47 = m/min 48 = m/s 49 = mbar		64h	34h	78h	USINT	5120	enum	1



Parameter	Description	Range of values	Decimal places	Class	Instance	Attribute	CIP data type	Net Id	Size	Qty mapped words
		50 = ms 51 = min 52 = MPa 53 = mwc 54 = N 55 = Nm 56 = Pa 57 = % 58 = psi 59 = rpm 60 = s 61 = V 62 = W 63 = W/m ² 64 = Wh/m ²								
C10.2.2	Dec. Point Eng. Unit 1	0 to 3	0	64h	34h	79h	USINT	5121	8bit	1
C10.2.3	Engineering Unit 2	0 = No Unit 1 = A 2 = bar 3 = °C 4 = CPM 5 = CV 6 = ft ³ 7 = ft ³ /h 8 = ft ³ /min 9 = ft ³ /s 10 = m ³ 11 = m ³ /h 12 = m ³ /min 13 = m ³ /s 14 = °F 15 = ft 16 = ft/h 17 = ft/min 18 = ft/s 19 = gal 20 = gal/h 21 = gal/min 22 = gal/s 23 = H 24 = Hz 25 = HP 26 = h 27 = in 28 = lnWC 29 = K 30 = kg 31 = kgf 32 = kgf/cm ² 33 = kgf/m ²		64h	34h	7Ah	USINT	5122	enum	1



Parameter	Description	Range of values	Decimal places	Class	Instance	Attribute	CIP data type	Net Id	Size	Qty mapped words
		34 = kl/h 35 = kPa 36 = kW 37 = kWh 38 = l 39 = l/h 40 = l/min 41 = l/s 42 = lbf 43 = mA 44 = mca 45 = m 46 = m/h 47 = m/min 48 = m/s 49 = mbar 50 = ms 51 = min 52 = MPa 53 = mwc 54 = N 55 = Nm 56 = Pa 57 = % 58 = psi 59 = rpm 60 = s 61 = V 62 = W 63 = W/m ² 64 = Wh/m ²								
C10.2.4	Dec. Point Eng. Unit 2	0 to 3	0	64h	34h	7Bh	USINT	5123	8bit	1
C10.2.5	Engineering Unit 3	0 = No Unit 1 = A 2 = bar 3 = °C 4 = CPM 5 = CV 6 = ft ³ 7 = ft ³ /h 8 = ft ³ /min 9 = ft ³ /s 10 = m ³ 11 = m ³ /h 12 = m ³ /min 13 = m ³ /s 14 = °F 15 = ft 16 = ft/h 17 = ft/min		64h	34h	7Ch	USINT	5124	enum	1



Parameter	Description	Range of values	Decimal places	Class	Instance	Attribute	CIP data type	Net Id	Size	Qty mapped words	
		18 = ft/s 19 = gal 20 = gal/h 21 = gal/min 22 = gal/s 23 = H 24 = Hz 25 = HP 26 = h 27 = in 28 = InWC 29 = K 30 = kg 31 = kgf 32 = kgf/cm ² 33 = kgf/m ² 34 = kl/h 35 = kPa 36 = kW 37 = kWh 38 = l 39 = l/h 40 = l/min 41 = l/s 42 = lbf 43 = mA 44 = mca 45 = m 46 = m/h 47 = m/min 48 = m/s 49 = mbar 50 = ms 51 = min 52 = MPa 53 = mwc 54 = N 55 = Nm 56 = Pa 57 = % 58 = psi 59 = rpm 60 = s 61 = V 62 = W 63 = W/m ² 64 = Wh/m ²									
C10.2.6	Dec. Point Eng. Unit 3	0 to 3	0	64h	34h	7Dh	USINT	5125	8bit	1	
C10.2.7	Engineering Unit 4	0 = No Unit 1 = A		64h	34h	7Eh	USINT	5126	enum	1	



Parameter	Description	Range of values	Decimal places	Class	Instance	Attribute	CIP data type	Net Id	Size	Qty mapped words	
		2 = bar 3 = °C 4 = CPM 5 = CV 6 = ft³ 7 = ft³/h 8 = ft³/min 9 = ft³/s 10 = m³ 11 = m³/h 12 = m³/min 13 = m³/s 14 = °F 15 = ft 16 = ft/h 17 = ft/min 18 = ft/s 19 = gal 20 = gal/h 21 = gal/min 22 = gal/s 23 = H 24 = Hz 25 = HP 26 = h 27 = in 28 = lnWC 29 = K 30 = kg 31 = kgf 32 = kgf/cm² 33 = kgf/m² 34 = kl/h 35 = kPa 36 = kW 37 = kWh 38 = l 39 = l/h 40 = l/min 41 = l/s 42 = lbf 43 = mA 44 = mca 45 = m 46 = m/h 47 = m/min 48 = m/s 49 = mbar 50 = ms 51 = min 52 = MPa									



Parameter	Description	Range of values	Decimal places	Class	Instance	Attribute	CIP data type	Net Id	Size	Qty mapped words
C10.2.8	Dec. Point Eng. Unit 4	53 = mwc 54 = N 55 = Nm 56 = Pa 57 = % 58 = psi 59 = rpm 60 = s 61 = V 62 = W 63 = W/m ² 64 = Wh/m ² 0 to 3	0	64h	34h	7Fh	USINT	5127	8bit	1
C11 Configuration\HMI										
C11.1	Configuration									
C11.1.1	Time Zone	0 = UTC-12:00 1 = UTC-11:30 2 = UTC-11:00 3 = UTC-10:30 4 = UTC-10:00 5 = UTC-09:30 6 = UTC-09:00 7 = UTC-08:30 8 = UTC-08:00 9 = UTC-07:30 10 = UTC-07:00 11 = UTC-06:30 12 = UTC-06:00 13 = UTC-05:30 14 = UTC-05:00 15 = UTC-04:30 16 = UTC-04:00 17 = UTC-03:30 18 = UTC-03:00 19 = UTC-02:30 20 = UTC-02:00 21 = UTC-01:30 22 = UTC-01:00 23 = UTC-00:30 24 = UTC+00:00 25 = UTC+00:30 26 = UTC+01:00 27 = UTC+01:30 28 = UTC+02:00 29 = UTC+02:30 30 = UTC+03:00 31 = UTC+03:30 32 = UTC+04:00 33 = UTC+04:30 34 = UTC+05:00		64h	02h	C4h	USINT	196	enum	1



Parameter	Description	Range of values	Decimal places	Class	Instance	Attribute	CIP data type	Net Id	Size	Qty mapped words
		35 = UTC+05:30 36 = UTC+06:00 37 = UTC+06:30 38 = UTC+07:00 39 = UTC+07:30 40 = UTC+08:00 41 = UTC+08:30 42 = UTC+09:00 43 = UTC+09:30 44 = UTC+10:00 45 = UTC+10:30 46 = UTC+11:00 47 = UTC+11:30 48 = UTC+12:00 49 = UTC+12:30 50 = UTC+13:00 51 = UTC+13:30 52 = UTC+14:00								
C11.1.2	Date/Hour	to	0	64h	02h	C2h	UDINT	194	NONE	2
C11.1.3	Language			64h	03h	65h	USINT	201	enum	1
		0 = Português 1 = English 2 = Español 3 = Deutsch								
C11.1.4	Display Brightness	0 to 100 %	0	64h	03h	74h	UINT	216	16bit	1
C11.1.5	Contrast	0 to 100 %	0	64h	03h	75h	UINT	217	16bit	1
C11.2	Main Screen									
C11.3	User									
C11.3.1	Login									
C11.3.2	Change password									
C12 Configuration\Backup										
C12.1	Load Parameters	0 = Not Used 1 = Default 60 Hz 2 = Default 50 Hz 3 = Param. Set 1 -> CFW 4 = Param. Set 2 -> CFW 5 = Param. Set 3 -> CFW 6 = CFW -> Param. Set 1 7 = CFW -> Param. Set 2 8 = CFW -> Param. Set 3 9 = SD Card -> CFW 10 = CFW -> SD Card 11 = HMI -> CFW 12 = CFW -> HMI		64h	03h	68h	USINT	204	enum	1
A1 Application\User Parameters										



WEG Drives & Controls - Automação LTDA.
Jaraguá do Sul – SC – Brazil
Phone 55 (47) 3276-4000 – Fax 55 (47) 3276-4020
São Paulo – SP – Brazil
Phone 55 (11) 5053-2300 – Fax 55 (11) 5052-4212
automacao@weg.net
www.weg.net