

TPDflex DC Converters

Frame A

Hardware Service Manual

Language: English

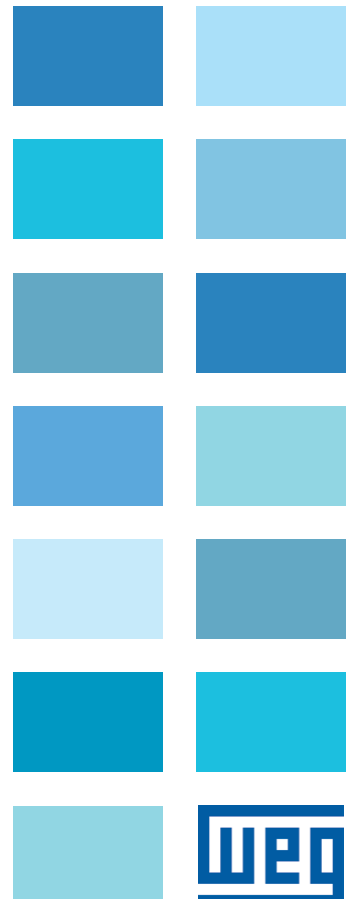

Important User Information

Read this document and any additional resources regarding installation, configuration, and operation of this equipment before installing, configuring, operating, or maintaining it. Users must follow installation and wiring instructions and comply with all applicable codes, laws, and standards.

All activities, including installation, adjustments, commissioning, use, assembly, disassembly, and maintenance, must be performed by properly trained personnel following applicable safety practices.

Using the equipment in ways not specified by the manufacturer may reduce its protective features.

Examples and diagrams are for illustrative purposes only and do not replace proper engineering judgment for actual installations.

No patent liability is assumed regarding the use of the information, circuits, equipment, or software described.

Reproduction of this manual, in whole or in part, is prohibited without written permission.

Notes in this manual highlight safety considerations where necessary.



WARNING: Identifies information about practices or circumstances that can cause an explosion in a hazardous environment, which may lead to personal injury or death, property damage, or economic loss.



ATTENTION: Identifies information about practices or circumstances that can lead to personal injury or death, property damage, or economic loss. Attentions help you identify a hazard, avoid a hazard, and recognize the consequence.

IMPORTANT Identifies information that is critical for successful application and understanding of the product.

These labels may also be on or inside the equipment to provide specific precautions.



SHOCK HAZARD: Labels may be on or inside the equipment, for example, a drive or motor, to alert people that dangerous voltage may be present.



BURN HAZARD: Labels may be on or inside the equipment, for example, a drive or motor, to alert people that surfaces may reach dangerous temperatures.



ARC FLASH HAZARD: Labels may be on or inside the equipment, for example, a motor control center, to alert people to potential Arc Flash. Arc Flash will cause severe injury or death. Wear proper Personal Protective Equipment (PPE). Follow ALL Regulatory requirements for safe work practices and for Personal Protective Equipment (PPE).

The following icon may appear in the text of this document.



Identifies information that is useful and can help to make a process easier to do or easier to understand.

	Preface	7
	Summary of Changes	7
	 Chapter 1	
Before You Begin Testing, Maintenance, or Repairs	General Safety Precautions	9
	Hardware Description	10
	Commonly Used Tools	11
	Service Tools	11
	Software Tools	12
	 Chapter 2	
Component Test Procedures	Visual Component Inspection	14
	Troubleshoot a Control Power Supply Failure	14
	Test the Switching Power Supply and Pulse Transformer Boards	15
	Test the Control and Field Board Connections	15
	Troubleshoot an Armature Bridge Failure	21
	Low or Incorrect Field Current	25
	Check the Armature SCR Modules	28
	Check the Pulse Transformer Board	31
	Check the Field SCR/Dual Diode Module (Drives Only)	34
	Check the DC Tachometer	36
	Check the Resolver Interface Board	36
	 Chapter 3	
Part Replacement Procedures	Replacement Part Kits	41
	Remove Power from the Drive	43
	Switching Power Supply Fuse Replacement	44
	Remove the Fuse on the Switching Power Supply Circuit Board	44
	Install the Fuse on the Switching Power Supply Circuit Board	44
	Field Circuit Fuse Replacement	44
	Remove the Field Circuit Fuses	44
	Install the Field Circuit Fuses	45
	DPI / HIM Assembly Replacement	45
	Remove the DPI / HIM Assembly from the Protective Cover	45
	Install the DPI / HIM Assembly on the Protective Cover	46
	Protective Cover Replacement	47
	Remove the Protective Covers	47
	Install the Protective Covers	49
	Communication Adapter and EMI Shield Replacement	49
	Remove the Communication Adapter and EMI Shield	49
	Install the Communication Adapter and EMI Shield	51
	Resolver Feedback and Interface Circuit Board Replacement	52
	Remove the Resolver Feedback and Interface Circuit Boards	52
	Install the Resolver Feedback and Interface Circuit Boards	55
	I/O Expansion Circuit Board Replacement	56

Remove the I/O Expansion Circuit Board.....	56
Install the I/O Expansion Circuit Board	58
115V AC to 24V DC I/O Converter Circuit Board Replacement	58
Remove the 115V AC to 24V DC I/O Converter Circuit Board.....	58
Install the 115V AC to 24V DC I/O Converter Circuit Board	59
Control Circuit Board Replacement	59
Remove the Control Circuit Board.....	59
Install the Control Circuit Board	64
Control EMI Shield and Control Circuit Board Replacement.....	64
Remove the Control EMI Shield and Control Circuit Board.....	64
Install the Control EMI Shield and Control Circuit Board	67
Pulse Transformer and Switching Power Supply Circuit Boards Replacement.....	67
Remove the Pulse Transformer and Switching Power Supply Circuit Boards....	67
Install the Pulse Transformer and Switching Power Supply Circuit Boards	73
Install the Configured Pulse Transformer Circuit Board and the Switching Power Supply Circuit Boards	79
AC Current Transducer Replacement.....	79
Remove the AC Current Transducers	79
Install the AC Current Transducers.....	84
Power Traces Circuit Board Replacement.....	85
Remove the Power Traces Circuit Board.....	85
Install the Power Traces Circuit Board.....	88
Field SCR/Dual Diode Module and Field Circuit Board Replacement	88
Remove the Field SCR/Dual Diode Module and Field Circuit Board.....	88
Install the Field SCR/Dual Diode Module and Field Circuit Board	93
Bimetal Thermostat Replacement	94
Remove the Bimetal Thermostat.....	94
Install the Bimetal Thermostat	94
SCR Module Replacement.....	95
Remove the SCR Modules.....	95
Install the SCR Modules	103
Cooling Fan Replacement	103
Remove the Cooling Fan.....	103
Install the Cooling Fan	107

Chapter 4

Start Up After Repair

Test With the Motor, Without a Mechanical Load	109
--	-----

Appendix A

Schematics

List of Schematic Diagrams	111
----------------------------------	-----

Appendix B

Circuit Board Layouts and Connections

List of Circuit Board Layouts.....	121
Pulse Transformer Board.....	122
Switching Power Supply Board	125
Control Board	126
.....	127
Field Board.....	128

Flow Charts**Appendix C**

List of Flow Charts	129
Control Power Supply Failure	130
Field Current Loss Failure	131
No Field Current Flow Chart.....	131
Low or Incorrect Field Current Flow Chart.....	132

Index 133

Do you need help?.....	135
------------------------	-----

Notes:

This manual contains component test and hardware replacement procedures for TPDflex DC frame A drives, 1.5...75 Hp (1.2...56 kW).

This manual is intended for qualified service personnel responsible for troubleshooting and repairing TPDflex DC Converters. You should have previous experience with, and basic understanding of, electrical terminology, procedures, required troubleshooting equipment, equipment protection procedures and methods, and safety precautions.

It is highly recommended that you obtain a copy of the TPDflex DC Converters User Manual, which contain fault/alarm and programming information to assist you in troubleshooting drive errors and determining if repairs are necessary. See [Additional Resources on page 135](#) for information on related publications and how to obtain manuals.

Summary of Changes

This manual contains new and updated information.

Topic	Page
Added Series B Control Board Testpoints - Upper Left	17
Added Series B Control Board Testpoints - Upper Right	19
Added Combined AC Line Input Signal Testpoints Series B	21
Added Series B figure for Good SCR Gate Pulse and Armature Current Signals	22
Added Series B Good SCR Armature Voltage and Motor Current Signal	23
Added Series B Open Thyristor	25
Added Four Series B Control Circuit Boards Replacement	62
Added Series B Control Board	126
Added table for Series B Control Board to Field Board Connections	127



Catalog Number SK-20P-S5RPI, now has a Series B, which has been added to this publication; connections and terminals between series A and B are in the same locations except for components and test points, refer to images on [page 62](#) for more details.

Notes:

Before You Begin Testing, Maintenance, or Repairs

Topic	Page
General Safety Precautions	9
Hardware Description	10
Commonly Used Tools	11

This chapter provides information you should know before you begin tests, maintenance, or repairs on drive components.

General Safety Precautions

Read the following precautions before you begin testing components, performing maintenance or repairing the drive.



ATTENTION: Only qualified personnel familiar with DC drives, field controllers, and associated machinery should plan or implement the installation, startup, and subsequent maintenance of the system. Failure to comply may result in personal injury and/or equipment damage.



ATTENTION: This drive contains Electrostatic Discharge (ESD) sensitive parts and assemblies. Static control precautions are required when installing, testing, servicing or repairing this assembly. Component damage may result if ESD control procedures are not followed. If you are not familiar with static control procedures, reference A-B publication [8000-4.5.2](#), "Guarding Against Electrostatic Damage" or any other applicable ESD protection handbook.



ATTENTION: Severe injury or death can result from electrical shock, burn, or unintended actuation of controlled equipment. Hazardous voltages may exist in the drive enclosure even with the circuit breaker in the off position. Recommended practice is to disconnect and lock out control equipment from power sources. If it is necessary to work in the vicinity of energized equipment, the safety related work practices of NFPA 70E, Electrical Safety Requirements for Employee Workplaces, must be followed. **DO NOT** work alone on energized equipment.



ATTENTION: Potentially fatal voltages may result from improper usage of an oscilloscope and other test equipment. The oscilloscope chassis may be at a potentially fatal voltage if not properly grounded. If an oscilloscope is used to measure high voltage waveforms, use only a dual channel oscilloscope in the differential mode with X 100 probes. It is recommended that the oscilloscope be used in the A minus B Quasi-differential mode with the oscilloscope chassis correctly grounded to an earth ground.



ATTENTION: Remove power before making or breaking cable connections. When you remove or insert a cable connector with power applied, an electrical arc may occur. An electrical arc can cause personal injury or property damage by:

- sending an erroneous signal to your system's field devices, causing unintended machine motion
- causing an explosion in a hazardous environment

Electrical arcing causes excessive wear to contacts on both the module and its mating connector. Worn contacts may create electrical resistance.



ATTENTION: HOT surfaces can cause severe burns. **Do not** touch the heat sink surface during operation of the drive. After disconnecting power allow time for cooling.

Hardware Description

The TPDflex DC Converter contains a power structure that has an armature and field supply. The armature supply consists of a three-phase, full wave rectified, dual bridge, capable of two or four quadrant output. The field supply consists of single phase, full wave rectified bridge. Also associated with the power structure, are incoming line protection devices and contactor and dynamic brake control circuits.

Verify that you are working on a Frame A drive by checking the data nameplate located on the side of the drive. The frame size is printed just above the serial number in the lower right corner of the label.

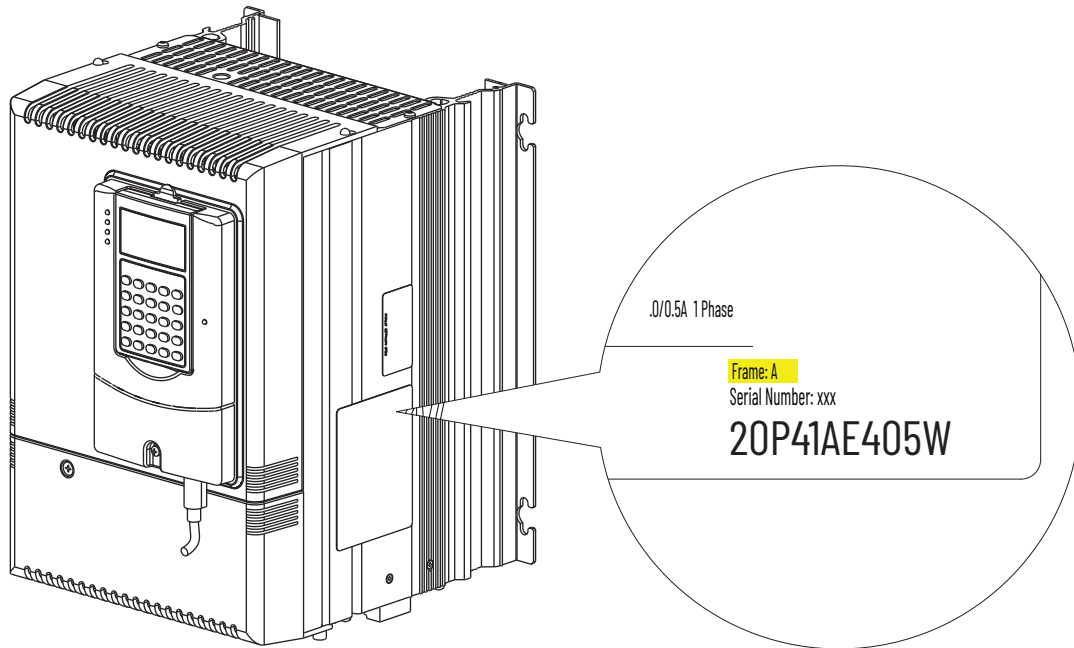

Commonly Used Tools

Service Tools

This list of basic service tools which will cover needs of tools for repair and maintenance measurements.

Item	Details
Digital multimeter	Digital multimeter, capable of ac and dc voltage, continuity, resistance and forward diode bias tests. Fluke model 87 III or equivalent (recommended).
Oscilloscope	Portable, digitizing, dual channel scope, with isolation
Current clamp	3x drive rated armature current output
Soldering station	Soldering / de soldering
Torque wrench	1...12 N•m
Torque wrench	6...50 N•m
Box wrench	7 mm, 8 mm, 10 mm, 13 mm, 17 mm, 19 mm, 22 mm
Socket extension	230 mm
Wrench	7 mm, 8 mm, 10 mm, 13 mm, 17 mm, 19 mm, 22 mm
Wire cutter	
Nose pliers	
Crimping tools	For cable terminals 1.5...240
Angle wrench	
Screw drivers:	
Flat nose	7 x 2 mm
Phillips	#1, 2, 3
Hexagonal wrench	#4, 5, 6
ESD-protected place of work	Working surface, Floor covering, seat and ground connections
ESD-protective clothing	Wrist wrap, shoes, overall clothing (coat)

Software Tools

You can use Connected Components Workbench® software or DriveExecutive™ software to monitor, upload, or download system parameters. You can also view current alarm and fault information.

Component Test Procedures

Topic	Page
Save the Parameter Configuration	13
Visual Component Inspection	14
Troubleshoot a Control Power Supply Failure	14
Troubleshoot an AC Undervoltage Fault	19
Troubleshoot an Armature Bridge Failure	21
Troubleshoot a Field Current Loss Fault	25
Power Component Test Procedures	27
Speed Feedback Device Tests	35
Thermistors and Thermal Switches	38
Relay Outputs	38
Create a Fault Report	38
What You Need When You Call Tech Support	38

This chapter provides general procedures for inspecting and testing the major components of the drive and includes recommendations for repairs. Due to the technical nature of this product and the variety of possible applications, not all possible fault conditions and troubleshooting solutions can be described in this manual.

IMPORTANT The diagnostic tests in this chapter should only be performed by qualified personnel and only when other corrective actions have failed. All tests assume that the control board connections have been properly made.

For common drive symptoms and corrective actions and fault troubleshooting information, see the Troubleshooting chapter in the TPDflex DC Converters User Manual, publication 1S7FLEXUM0.

Save the Parameter Configuration

It is recommended that you save the drive and communication adapter parameter configuration before performing any service. You can save the drive configuration in one of these ways:









- Upload the drive configuration to a HIM Set
- Upload the drive configuration to a DriveExecutive™ file (.dno)
- Export the drive configuration to Connected Components Workbench® file (.iuux)

See the specific software online help for instructions on how to save or export the drive configuration to an offline file.

Save to a HIM Set

Follow these steps to save the drive and adapter parameters to a HIM set.

1. On the HIM, access the **Memory Storage** menu.
2. Select the **HIM CopyCat** menu and press .

3. Select **Device** -> **HIM** and press .
4. Do one of the following:
 - If there is no existing HIM Set, enter a name using the  and  buttons to select the desired characters and press .
 - If there is an existing HIM Set, press  to overwrite it, or select **No** using the  button and use the  and  buttons to select the desired characters. Then press .

The HIM Set will be saved to nonvolatile memory.

Visual Component Inspection

Visually inspect the circuit boards and power components before energizing the drive for any of the component test procedures.

1. Read the General Safety Precautions on page 9.
2. Remove power from the drive (see page 43).
3. Remove the protective covers from the drive (see page 47).
4. Check components for burn marks, breakage, or foil delamination on all circuit boards.

Replace any of these components without further testing if they show evidence of burn marks, breakage, or foil delamination.

Troubleshoot a Control Power Supply Failure

If a drive Power Failure fault (F3) has occurred and the drive is inoperable by using the HIM or other means of control, a control power failure can have occurred. Complete these steps to determine where the control power failure has occurred.

1. Read the General Safety Precautions
2. Remove the protective covers from the drive (see page 49).
3. If installed, remove the resolver feedback option module (see page 52).
4. Measure the signal voltage at the control circuit board testpoints as indicated in the following table.

Name	Testpoint	For Testpoint Location See	Associated Connector-pin	Description
+ 5V	XY5	Figure 1 on page 16	XA-1 / XA-3 / XA-5	+5V digital supply
GNDD	XY6	Figure 1 on page 16	XA-2 / XA-4 / XA-6	+5V digital supply ground
GNDD	XY7	Figure 3 on page 18	XA-2 / XA-4 / XA-6	+5V digital supply ground
+15V	XY12	Figure 1 on page 16	XA-9 / XA-10	+15V analog supply
GND A	XY10	Figure 1 on page 16	XA-11 / XA-12	15V analog supply ground
-15 V	XY11	Figure 1 on page 16	XA-13 / XA-14	-15V analog supply
+24V	XY8	Figure 1 on page 16	XA-16	+24V terminal block
GNDV	XY9	Figure 1 on page 16	XA-15	+24V terminal block ground
+5VEXP	+5VEXP	Figure 3 on page 18	XP3-1 / XP3-2 / XP3-3	+5V for DPI expansion
+12VEXP	+12VEXP	Figure 3 on page 18	XP3-4 / XP3-5	+12V for DPI expansion
OVEXP	OVEXP	Figure 3 on page 18	XP3-7 / XP3-8 / XP3-9	DPI expansion ground

For a flow chart version of the steps that follow, see Control Power Supply Failure on page 130.

5. If any of the signals in the table in step 4 are incorrect or missing, verify that either 115V AC or 230V AC voltage is present at terminals U2 and V2 (control circuit power input).
 - If the voltage is present and correct, continue with step [6](#).
 - If the voltage is incorrect or missing, remove control power and verify the wiring and power source to U2, V2, and correct any problems. Test the voltage level again to verify that it is correct. If the voltage is correct, but the drive is still inoperable, continue with step [6](#).
6. Remove AC control power from terminals U2 and V2 and remove and test the fuse (F1) at the top of the drive. See Switching Power Supply Fuse Replacement on page [44](#) for fuse location.
 - If the fuse is open, continue with step [7](#).
 - If the fuse is not open, replace the switching power supply board.
7. Replace the fuse on the switching power supply board (see page [44](#)).
8. Disconnect the cable at connector XA on the control board. See Control Board Layout on page [126](#) for location of connector XA.
9. Apply AC control power to the drive.
 - If the fuse opens, continue with Test the Switching Power Supply and Pulse Transformer Boards on page [15](#).
 - If the fuse does not open, continue with Test the Control and Field Board Connections on page [15](#).

Test the Switching Power Supply and Pulse Transformer Boards

Complete these steps to test the switching power supply and pulse transformer circuit boards.

1. Replace the fuse on the switching power supply board (see page [44](#)).
2. Remove the switching power supply board from the pulse transformer board (see page [67](#)).
3. Reapply power to the switching power supply board only.
 - If the power supply fuse does not open, continue with step 5.
 - If the power supply fuse opens, replace the switching power supply board.
4. Remove all incoming AC voltage from the drive.
5. Check all external wiring that is connected to the pulse transformer board, including the motor PTC if used, for a possible short circuit condition. Repair any short circuit conditions if found.
6. If no short circuit conditions exist, replace the pulse transformer board.

Test the Control and Field Board Connections

Complete these steps to test the field circuit board.

1. Use an ohmmeter to check all input and output wiring on terminals 1...40 on terminal blocks TB1 and TB2 on the control board for a possible short circuit condition. Repair any short circuit conditions if found.
2. If an encoder and/or tachometer is used, use an ohmmeter to check all wiring on the respective terminals for a possible short circuit condition. Repair any short circuit conditions if found.
3. Remove the cables from connector XR and XFCD on the control board.
4. Use an ohmmeter to check between all voltage test points and common on the control board for possible short circuit conditions. Ohmmeter measurements greater than 200 k Ω are expected. If any low-resistance measurements are found, replace the control board.
5. Use an ohmmeter to measure between pins 1 and 2 and pins 3 and 2 on the XFCD cable connector on the field circuit board, if installed. Resistance measurements greater than 200 k Ω are expected for both tests. If a lower resistance value is measured, replace field board.

Figure 1 - Series A Control Board Testpoints - Upper Left

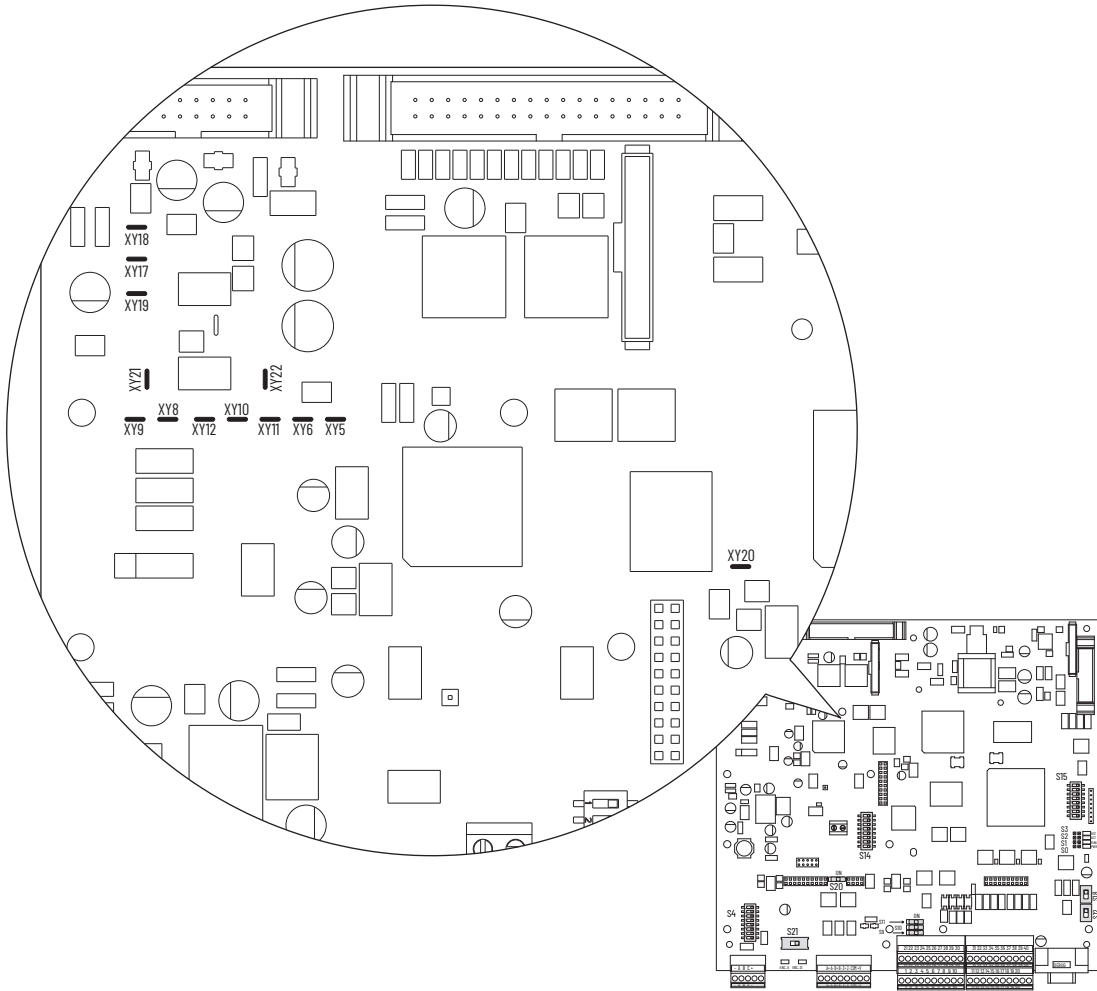

Figure 2 - Series B Control Board Testpoints - Upper Left

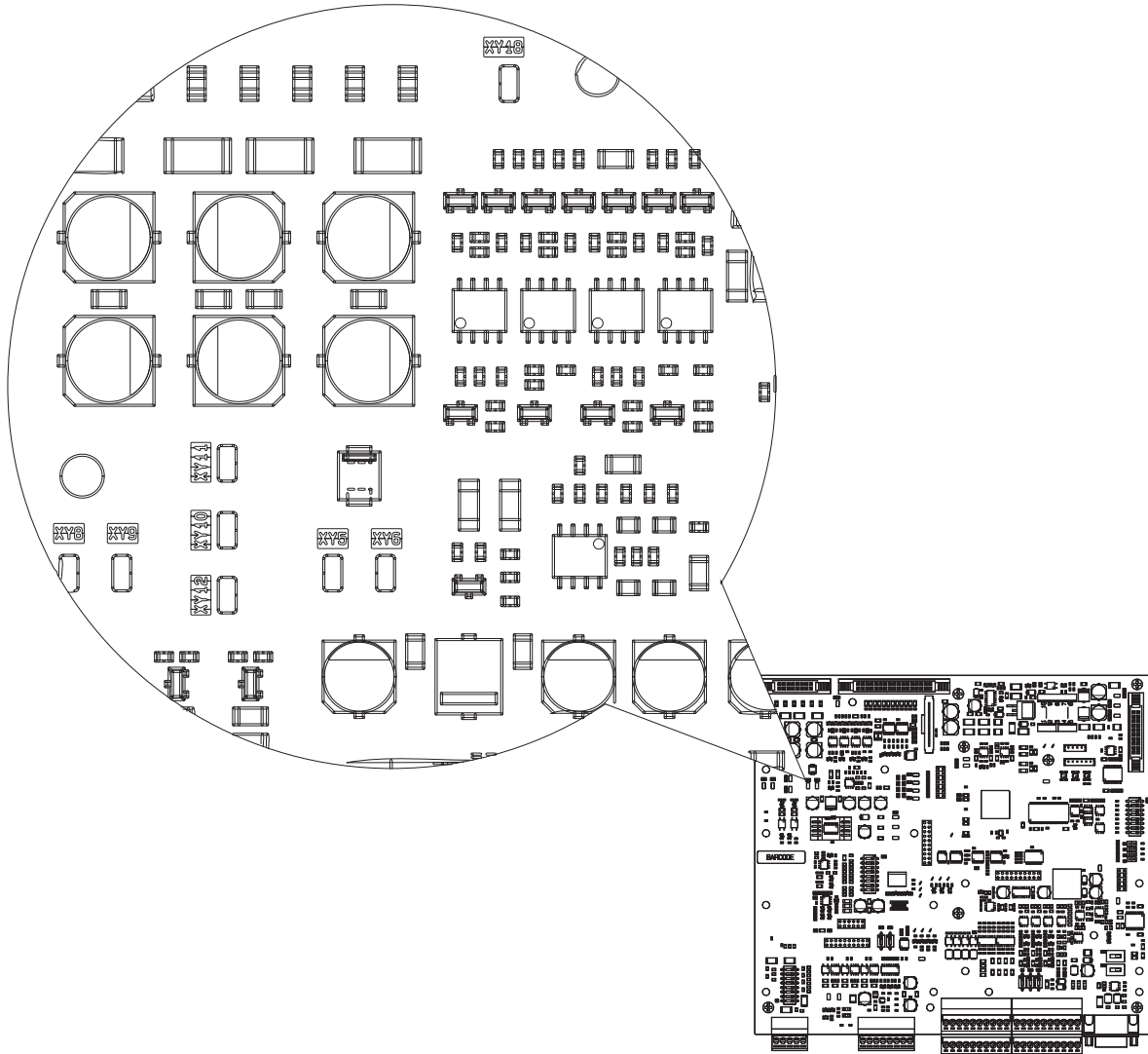

Figure 3 - Series A Control Board Testpoints - Upper Right

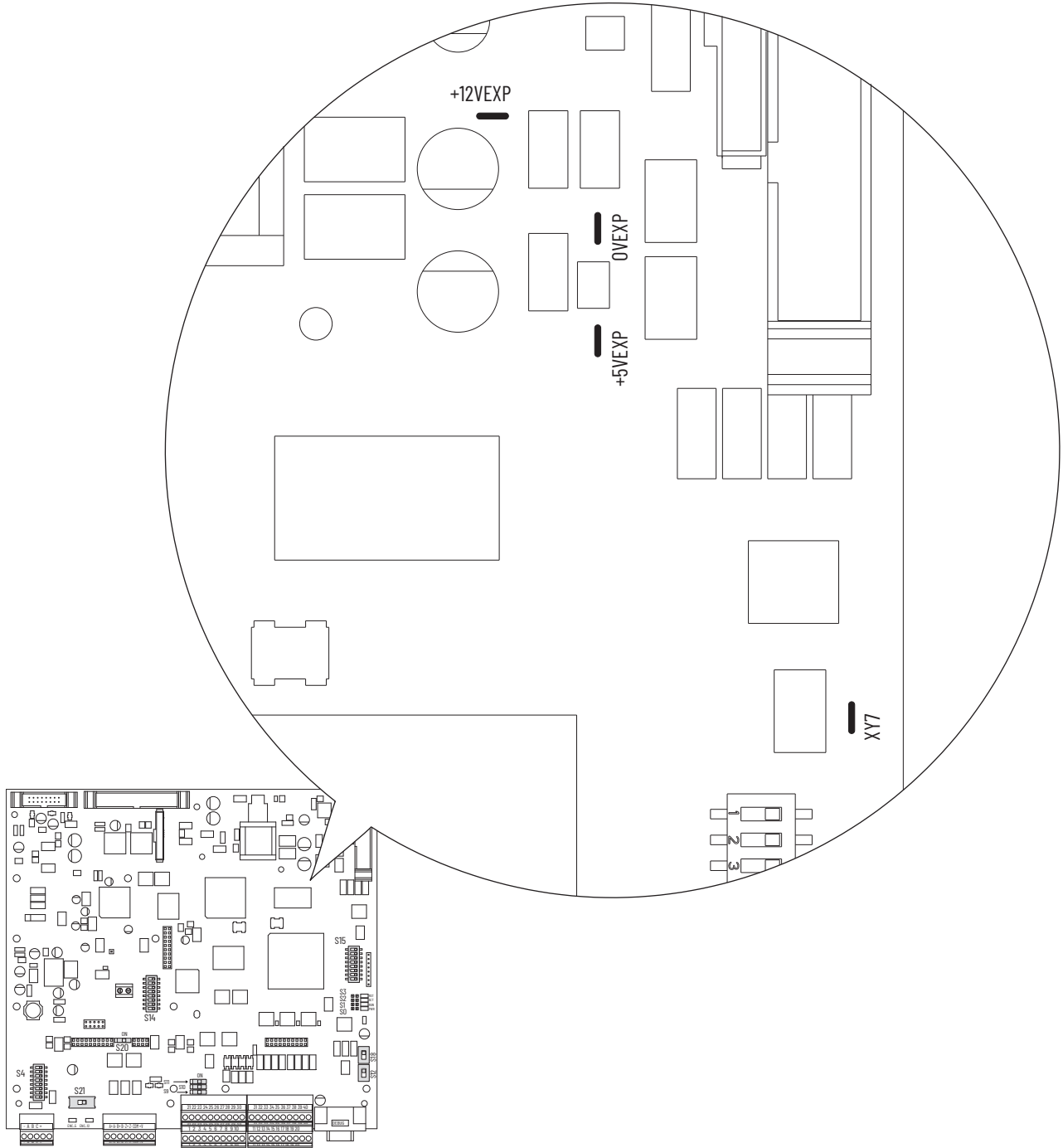
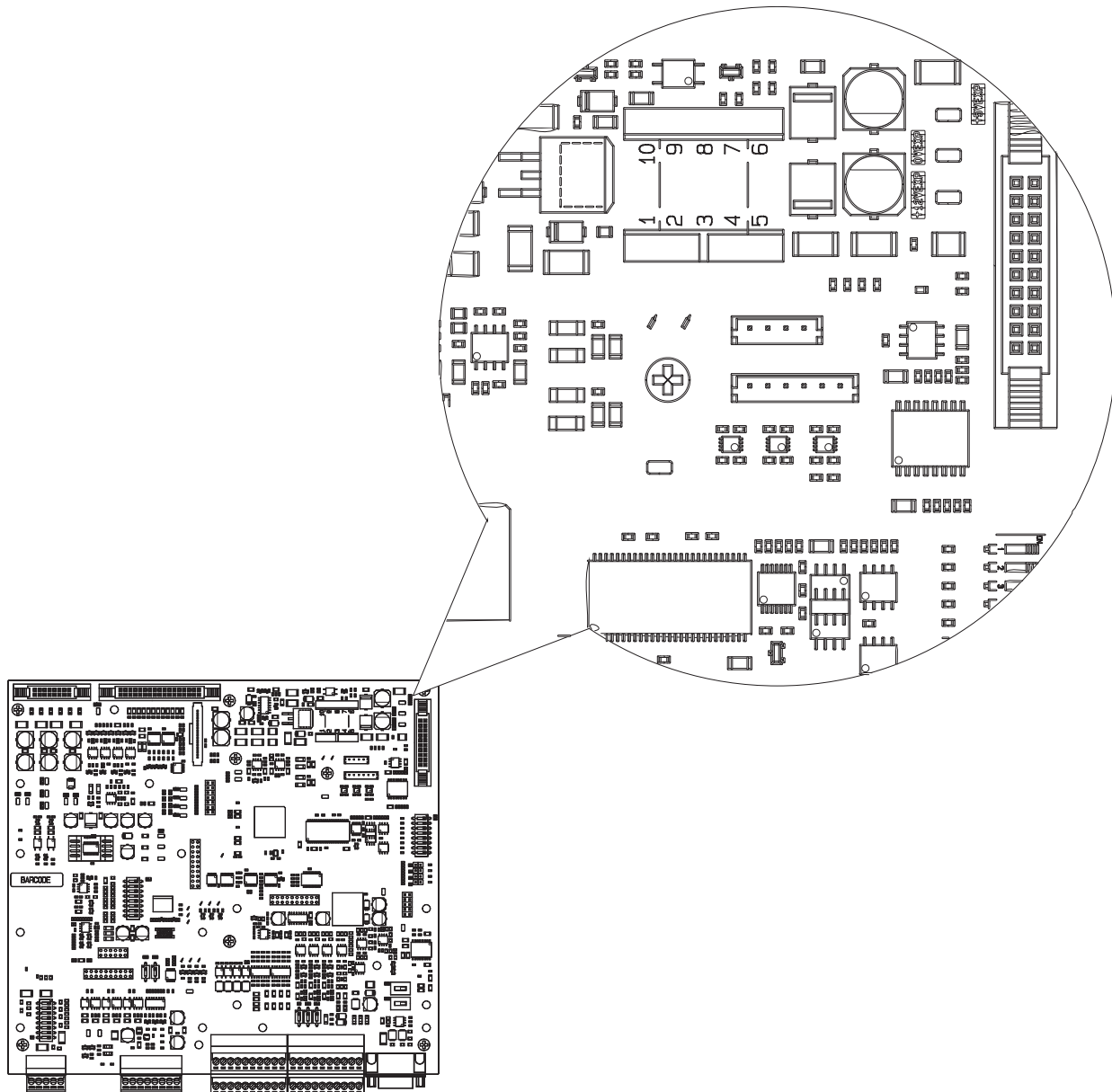

Figure 4 - Series B Control Board Testpoints - Upper Right



Troubleshoot an AC Undervoltage Fault

If one of the following occurs, measure the AC line input signals as directed in these steps:

- The drive faults with an AC Undervoltage Fault (F4)
- The value of parameter 466 [AC Line Voltage] does not equal the expected incoming AC line voltage



ATTENTION: Servicing energized equipment can be hazardous. Severe injury or death can result from electrical shock, burn, or unintended actuation of controlled equipment. Follow Safety related practices of NFPA 70E, ELECTRICAL SAFETY FOR EMPLOYEE WORKPLACES.

1. Read the General Safety Precautions on page [9](#).

2. Remove the protective covers from the drive (see page 47).
3. Use a voltmeter to measure the voltage at terminals U, V, and W of the drive. If an AC input contactor is used, the voltage must be measured on both the input and output sides of the contactor.

If any of the voltage measurements is incorrect or missing, remove incoming AC power and verify the wiring to the drive and the power supply source and correct any problems.

4. Using a voltmeter, measure the combined voltages of the AC lines on the following testpoints on the control board (all waveforms have a 2.5V offset). See Figure 1 on page 16 and Figure 3 on page 18 for location of the testpoints. See Figure 5 on page 22 for a schematic diagram.
 - If any of the voltage measurements are incorrect or missing, continue with step 5.
 - If the voltage measurements are correct but the value of parameter 466 [AC Line Voltage] is incorrect, replace the control board.
5. Remove the ribbon cable that is connected to XR on the control board and pulse transformer board and test the continuity of the cable using the measurements in Table 24 on page 124.
6. If the measurements on the XR cable are correct, replace the pulse transformer board.

Combined AC Line Input Signal Testpoints Series A

Incoming AC Line Voltage	Phases	Measure from Testpoint	...	To Testpoint	Peak to Peak Measurement	RMS Measurement
240V AC	V and U	XY22	...	XY18	1.42V AC	0.500V
	V and W	XY21	...	XY18		
480V AC	V and U	XY22	...	XY18	2.95V AC	1.040V
	V and W	XY21	...	XY18		
575V AC	V and U	XY22	...	XY18	2.85V AC	1.007V
	V and W	XY21	...	XY18		
690V AC	V and U	XY22	...	XY18	3.45V AC	1.220V
	V and W	XY21	...	XY18		

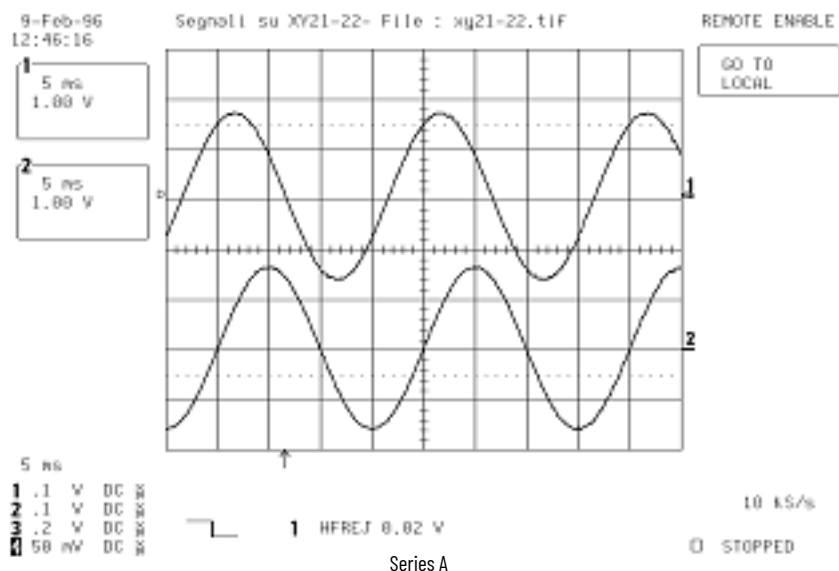

Combined AC Line Input Signal Testpoints Series B

Incoming AC Line Voltage	Phases	Measure from Testpoint	...	To Testpoint	Peak to Peak Measurement	RMS Measurement
240V AC	V and U	XY22	...	XY18	0.93V AC	0.330V
	V and W	XY21	...	XY18		
480V AC	V and U	XY22	...	XY18	1.86V AC	0.660V
	V and W	XY21	...	XY18		
575V AC	V and U	XY22	...	XY18	1.79V AC	0.630V
	V and W	XY21	...	XY18		
690V AC	V and U	XY22	...	XY18	1.80V AC	0.640V
	V and W	XY21	...	XY18		

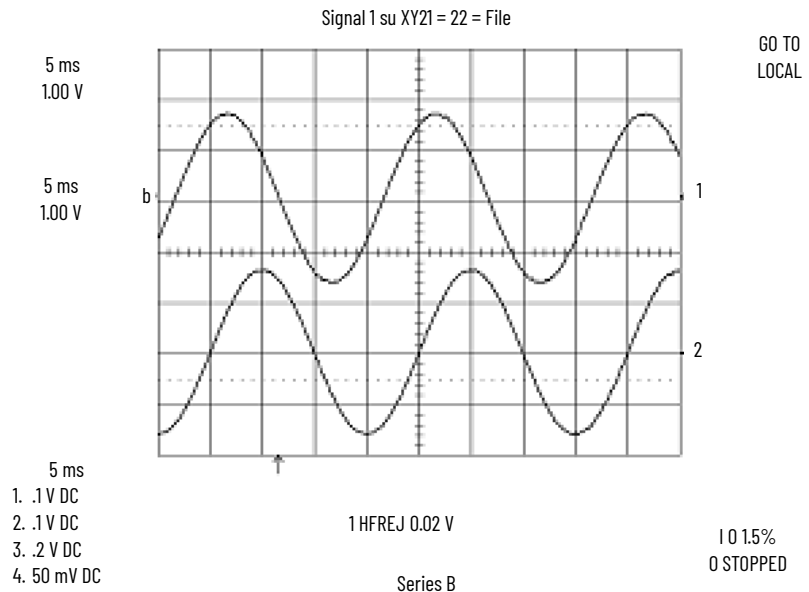

Troubleshoot an Armature Bridge Failure

If the drive is running unstable, or faults with an Overcurrent Fault (F13), an armature bridge failure can have occurred. The signals to and from the SCR bridges are transmitted via the ribbon cable that is connected to XR on the control board and can be measured at these points. See [Figure 29](#) on page [120](#) for location of the XR connector on the control board.

IMPORTANT These checks cannot be completed with an AC contactor in use.



ATTENTION: Servicing energized equipment can be hazardous. Severe injury or death can result from electrical shock, burn, or unintended actuation of controlled equipment. Follow Safety related practices of NFPA 70E, ELECTRICAL SAFETY FOR EMPLOYEE WORKPLACES.

1. Read the General Safety Precautions on page [9](#).
2. Remove the protective covers from the drive (see page [47](#)).

- If a DC output contactor is installed, disconnect the cable from XR on the control board and measure the signal for each SCR gate as indicated in this table:

Signal Name	XR Cable Pin	Gate		Note
		MP	MN	
IT1	27	G1	G04	—
IT2	29	G2	G05	
IT3	31	G3	G06	
IT4	21	G4	G01	
IT5	23	G5	G02	
IT6	25	G6	G03	
MN	33	—	—	Negative bridge MN - active when high (+5V)
MP	34	—	—	Positive bridge MP - active when high (+5V)

Figure 5, Figure 6, and Figure 7 on page 23 are examples of gate pulse, current, and voltage signal measurements taken on an SCR. In these figures:

- The current signal is taken on the testpoint XY17 (+2.5V offset; +0.6V=Drive size current).
- The voltage signal is taken on the testpoint XY19 (+2.5V offset).
- The ground signal is taken on either testpoint XY10 or XY18.

Figure 5 - Good SCR Gate Pulse and Armature Current Signals Example

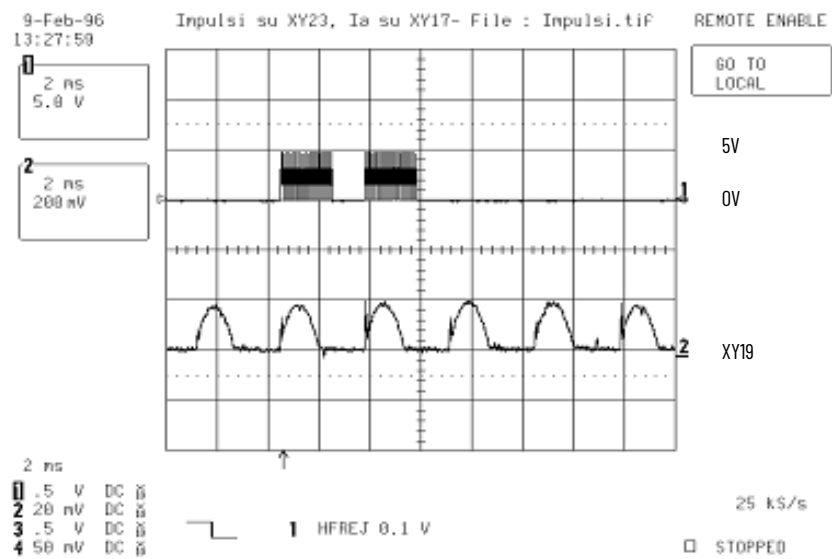
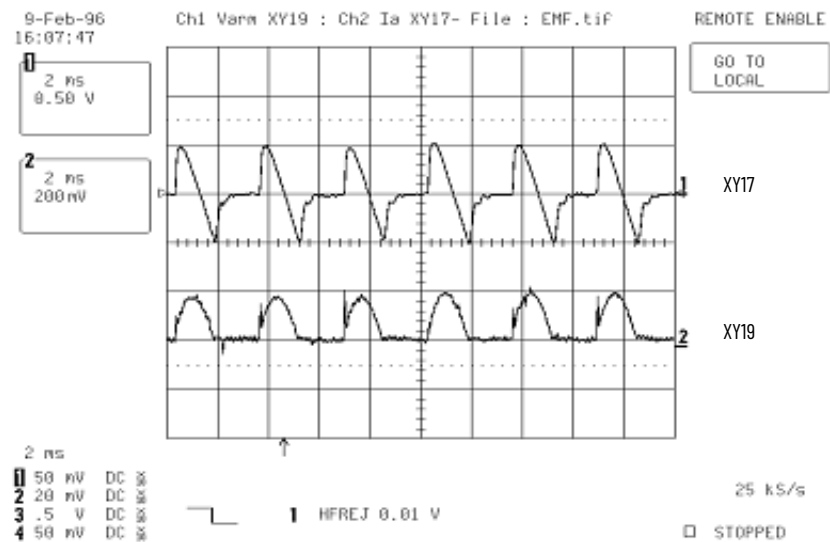
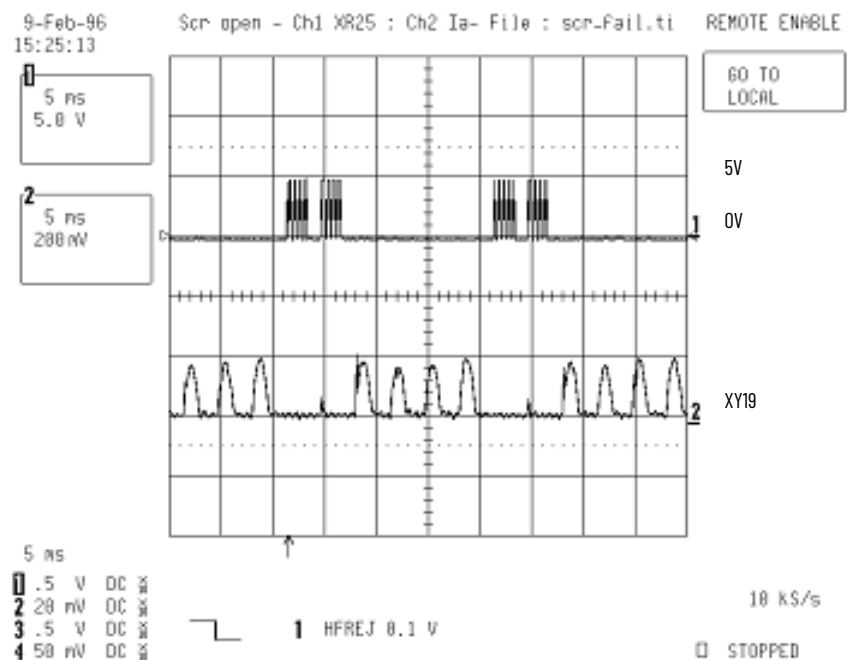

Figure 6 - Good SCR Armature Voltage and Motor Current Signal Example



A malfunctioning thyristor is connected to the relative gate. For example, if the tested signal is at XR25 and the positive bridge is active (MP high) from the following figure you can deduce that SCR connected to gate G6 is open.

Figure 7 - Open Thyristor Example



[Figure 8](#), [Figure 9](#), and [Figure 10](#) on page 23 are examples of gate pulse, current, and voltage signal measurements taken on an SCR. In these figures:

- The current signal is taken on the testpoint XY17 (+2.53V offset; +0.6V=Drive size current).
- The voltage signal is taken on the testpoint XY19 (+1.5V offset).
- The ground signal is taken on either testpoint XY10 or XY18.

Figure 8 - Good SCR Gate Pulse and Armature Current Signals Series B Example

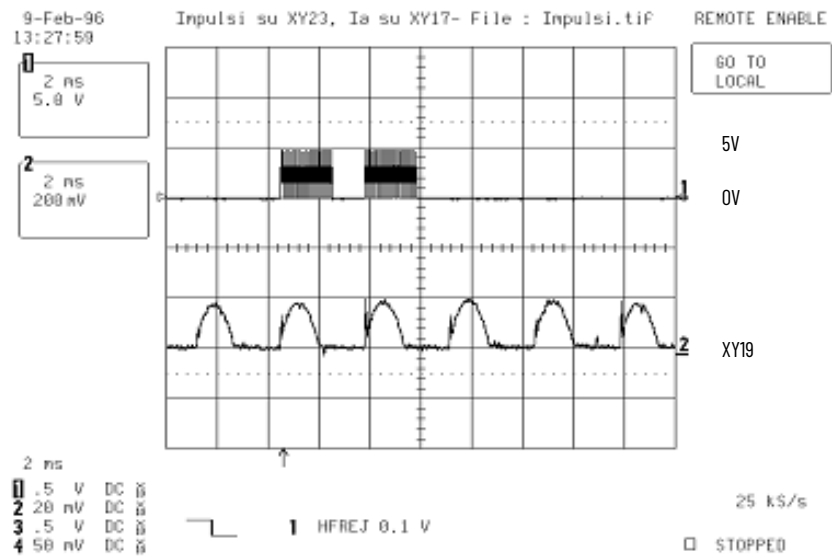
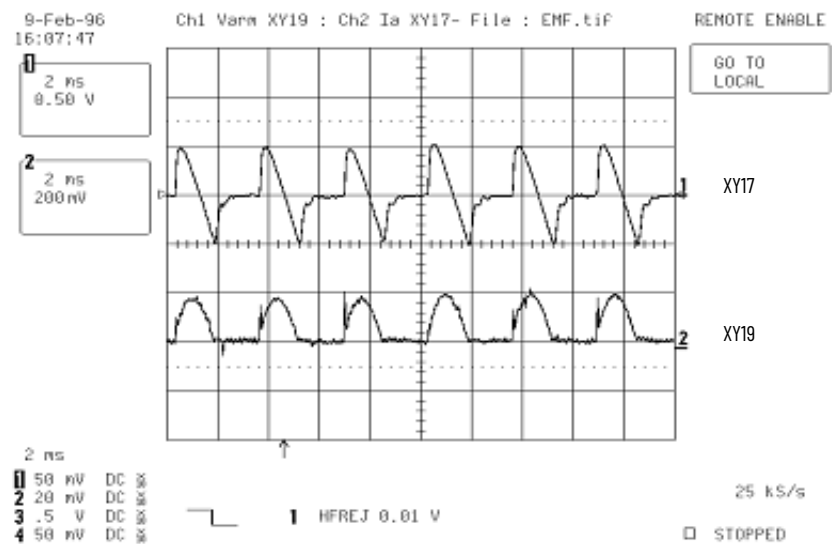
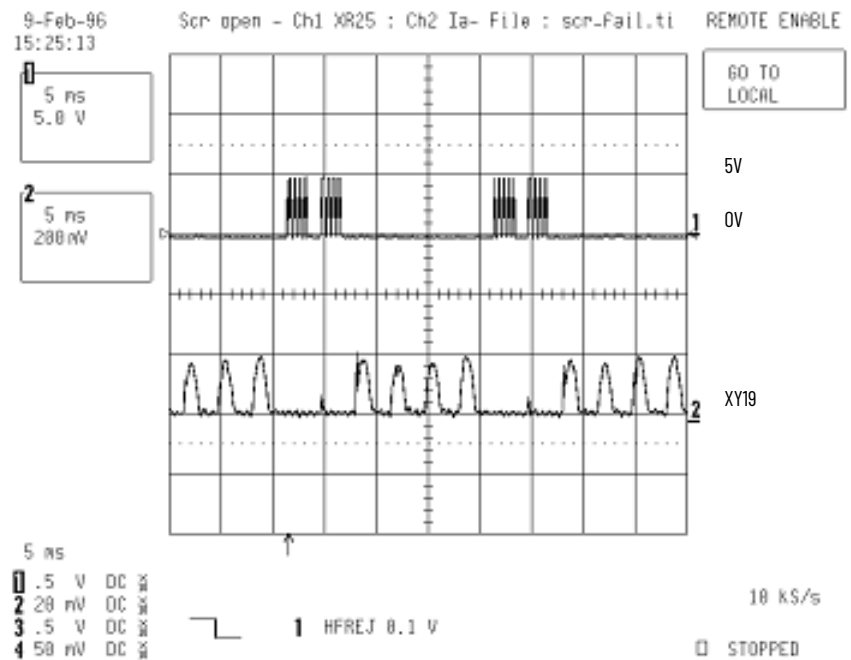

Figure 9 - Good SCR Armature Voltage and Motor Current Signal Series B Example



A malfunctioning thyristor is connected to the relative gate. For example, if the tested signal is at XR25 and the positive bridge is active (MP high) from the following figure you can deduce that SCR connected to gate G6 is open.

Figure 10 - Open Thyristor Series B Example



Troubleshoot a Field Current Loss Fault

Low or Incorrect Field Current

If the drive faults with a “Field Current Loss” fault (F6) and there is low or incorrect field current present at the motor, as seen in parameter 351 [Field Current], complete the steps in Low or Incorrect Field Current on page 25. If the drive faults with a “Field Current Loss” fault (F6) and there is no field current present at the motor, as seen in parameter 351 [Field Current], complete the steps in No Field Current on page 26.

For a flow chart version of these steps, see Low or Incorrect Field Current Flow Chart on page 132.

1. Read the General Safety Precautions on page 9.
2. Verify the actual value of parameter 351 [Field Current] by measuring the DC motor field current using a DC clamp.
3. Verify the following and make any necessary corrections:
 - The drive rated field bridge current is set correctly in parameter 374 [Drv Fld Brdg Cur].
 - DIP switch S14 is configured to correctly (according to the instructions in the TPDflex DC Converters User Manual, publication 1S7TFLEXUM0). See Control Board on page 126 for DIP switch location.
4. Verify that the value of parameter 280 [Nom Mtr Fld Amps] matches the rated field current value on motor nameplate and make any necessary corrections.
5. Remove the protective covers from the drive (see page 47).
6. On the control board, measure the field current signal on the green LA-LB terminal (LA is the ground and LB is field current signal) and verify the following:
 - The measured value of the field current at LA-LB is equal to the value of parameter 374 [Drv Fld Brdg Cur].
 - The expected voltage across these terminals is 1.66V DC.

For lower field current values, the voltage will be proportional. For example, if the field is configured for 2 A and the motor is rated for 1.5 A, the measurement at LA-LB will be 1.245V DC ($1.5 / x = 2 / 1.66$).

- If the voltage measurement is incorrect, continue with step 7.

- If the voltage measurement is correct, but the “Field Current Loss” fault still exists, replace the control board.
7. By using an ohmmeter, measure the resistance across terminals LA-LB and verify the following:
- The value equals the equivalent resistance as indicated in this table (set with DIP switch S14 on the control board).

Field Curr Scale	Field Supply	S14-1	S14-2	S14-3	S14-4	S14-5	S14-6	S14-7	S14-8	Equivalent Resistance
1 A	10 A	OFF	OFF	OFF	OFF	OFF	ON	Not Used		1668
2 A	10 A	OFF	OFF	OFF	OFF	ON	OFF			845
3 A	10 A	OFF	OFF	OFF	OFF	ON	ON			560.9
5 A	10 A	OFF	ON	OFF	OFF	OFF	OFF			333.3
10 A	10 A	ON	OFF	OFF	OFF	OFF	OFF			168.5
13 A	14 A	ON	OFF	OFF	OFF	ON	ON			129.6

If the resistance measurement is incorrect, replace the field board.

No Field Current

For a flow chart version of these steps, see No Field Current Flow Chart on page [131](#).

1. Read the General Safety Precautions on page [9](#).
2. Remove the protective covers from the drive (see page [47](#)).
3. Verify that the correct AC voltage is present at terminals U1 and V1 on the bottom of the drive. See [Figure 19](#) on page [115](#) for a schematic diagram.
 - If the voltage is correct, continue with step 4.
 - If the voltage is incorrect or missing, remove power from the drive and verify the wiring to the drive and the power supply source and correct any problems. Test the voltage level again to verify that it is correct. If the voltage is correct, but the fault persists or parameter 351 [Field Current] is incorrect, continue with step 4.
4. Remove AC power to the drive and check the fuses at FU1 and FV1.
 - If the fuses are blown, complete the steps in Test Field Wiring and Voltage Signals.
 - If the fuses are not blown, complete the steps in Test Field Control Signals.

Test Field Wiring and Voltage Signals

1. Test the resistance of the motor field wiring and motor field for possible short circuits.
 - If there are no short circuits, continue with step 2.
 - If a short circuit exists, correct any problems.
2. Check the field SCR/dual diode module for a short circuit condition (see page [34](#)).
 - If there are no short circuits, continue with step 3.
 - If a short circuit exists, replace the field SCR/dual diode module.
3. Replace the field fuses at FU1 and FV1 and apply power to the drive.
4. If the field fuses blow, replace the field board.

Test Field Control Signals

1. Disconnect the cable from connector XR on the control board and measure the U1-V1 voltage synchronization signal at pin 11 on the cable. See [Figure 29](#) on page [120](#) for location of the XR connector on the control board.

This signal is a square wave signal with a 90° lag phase displacement as compared to the AC voltage signal.

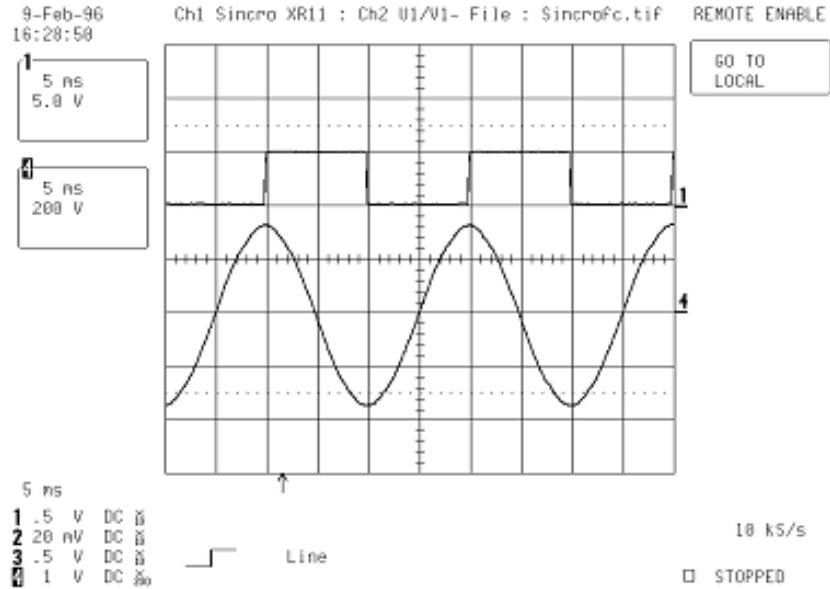

2. Measure the gate signals at pins XR-1 and XR-2 on the cable. The figure that is shown here displays the following signals from top to bottom:

Channel	Signal
1	U1-V1 Sync
4	Ie - LEM current feedback signal that is taken on LA-LB terminal
2	ITF1 pulse
3	ITF2 pulse

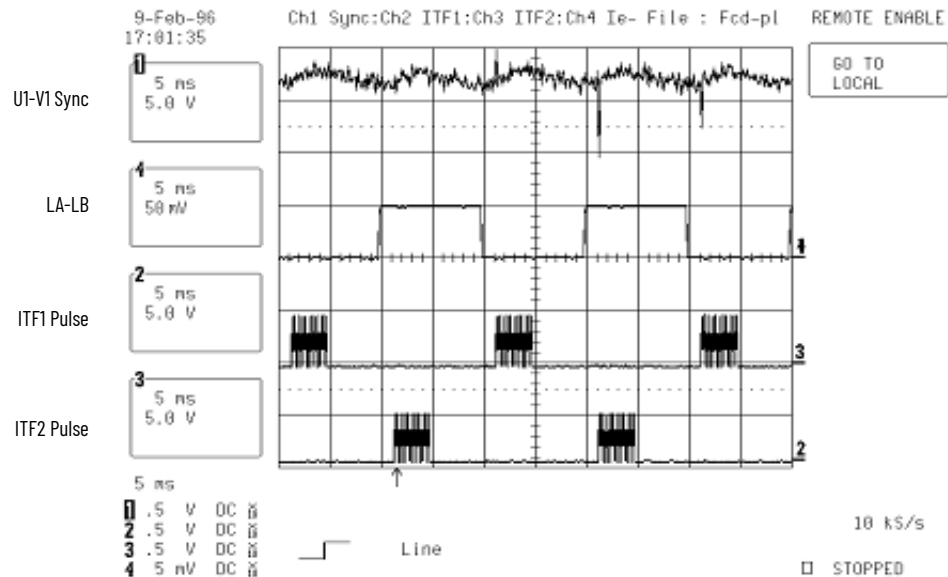

- If the gate signals are missing, replace the control board.
- If the gate signals are present, replace the field board.

Power Component Test Procedures

Follow the applicable procedure for the affected power components.

Check the Armature SCR Modules

The frame A TPDflex DC Converters armature supply consists of three (non-regenerative drives) or six (regenerative drives) SCR modules that are mounted on the main heat sink. One of the following can indicate a malfunction of any of these modules:

- An Overcurrent fault (F13)
- Blown or tripped incoming protection devices
- Erratic motor operation

If an armature bridge component malfunction is suspected, follow these steps.

1. Read the General Safety Precautions on page [9](#).
2. Remove power from the drive (see page [43](#)).
3. Verify that contactor power (if used) is removed.
4. Verify that power to an external field supply (if used) is removed.
5. Check the anode to cathode junction of each SCR. With a digital multimeter set to Ohms, measure the resistance across the SCRs (lead orientation is not critical).
 - For regenerative drives, see [Table 1](#) on page [28](#) and [Figure 11](#) on page [29](#).
 - For non-regenerative drives, see [Table 2](#) on page [29](#) and [Figure 12](#) on page [30](#).

If a low resistance is detected, determine which SCR module is damaged based on [Table 1](#) or [Table 2](#) and replace that module (see SCR Module Replacement on page [95](#)).

Table 1 - SCR Anode to Cathode Junction Measurements for Regenerative Drives

On SCR Module	SCR	Measure from Terminal	To Terminal	Nominal Meter Reading
1	1	U	C	"open circuit" or "MΩ" range
	4	U	D	
2	2	V	C	
	5	V	D	
3	3	W	C	
	6	W	D	
01	01	U	C	
	04	U	D	
02	02	V	C	
	05	V	D	
03	03	W	C	
	06	W	D	

Figure 11 - Regenerative Drive SCR Module Layout

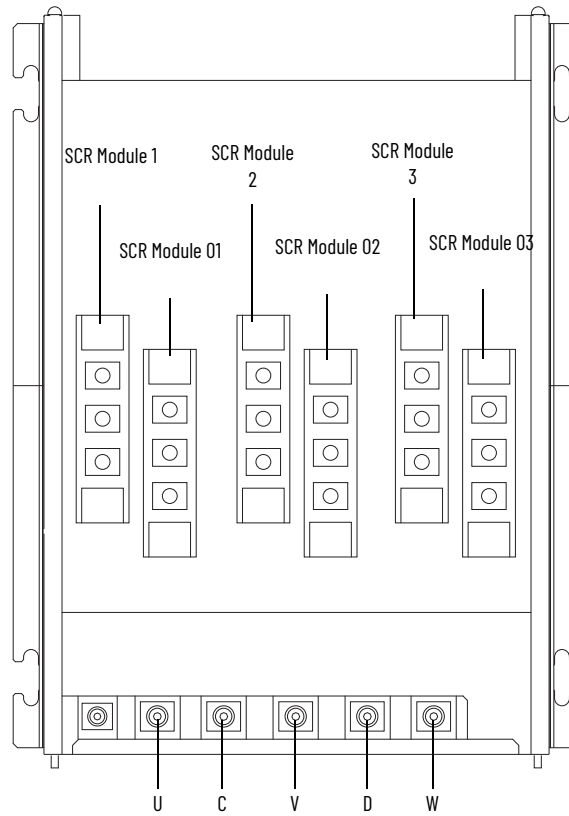
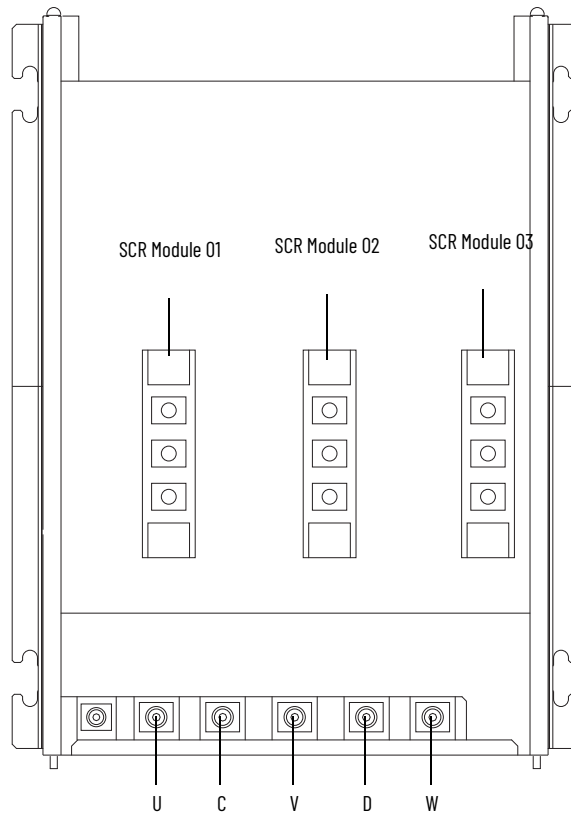

Table 2 - SCR Anode to Cathode Junction Measurements for Non-regenerative Drives

On SCR Module	SCR	Measure from Terminal	To Terminal	Nominal meter Reading
01	01	U	C	"open circuit" or "MΩ" range
	04	U	D	
02	02	V	C	
	05	V	D	
03	03	W	C	
	06	W	D	

Figure 12 - Non-regenerative Drive SCR Module Layout



6. Check the gate to cathode junction of each SCR. With a digital multimeter set to Ohms, measure the resistance of each SCR junction. For regenerative drives, refer to [Table 3](#) and [Figure 13](#). For non-regenerative drives, refer to [Table 4](#) on page [31](#) and [Figure 14](#) on page [31](#). If a measurement is outside of the range that is specified in these tables or if one reading deviates significantly from the majority, then module replacement can be necessary. See SCR Module Replacement on page [95](#).

Table 3 - SCR Gate to Cathode Junction Measurements for Regenerative Drives

On SCR Module	SCR	Measure from	To	Nominal Meter Reading
1	1	Pin 5	Pin 4	5...20 Ω ⁽¹⁾
	4	Pin 6	Pin 7	
2	2	Pin 5	Pin 4	
	5	Pin 6	Pin 7	
3	3	Pin 5	Pin 4	
	6	Pin 6	Pin 7	
01	01	Pin 6	Pin 7	
	04	Pin 5	Pin 4	
02	02	Pin 6	Pin 7	
	05	Pin 5	Pin 4	
03	03	Pin 6	Pin 7	
	06	Pin 5	Pin 4	

(1) The actual reading varies depending upon the SCR manufacturer. Verify that the actual measured value is consistent for all SCRs.

Figure 13 - SCR Connection Pinouts for Regenerative Drives

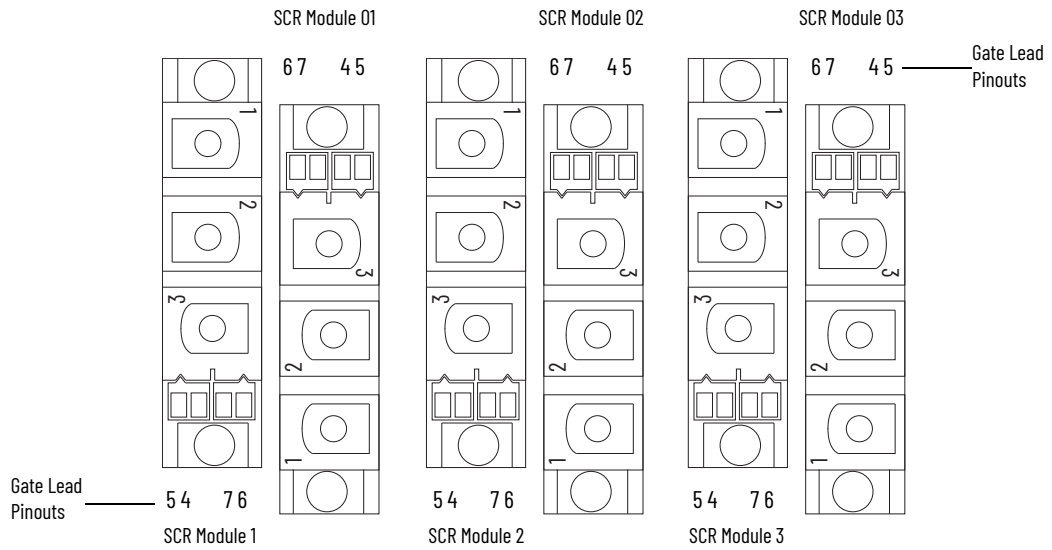
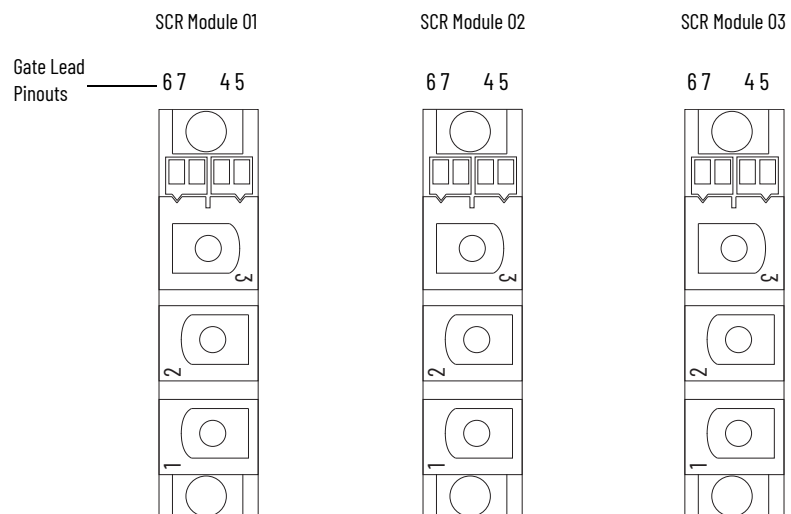

Table 4 - SCR Gate to Cathode Junction Measurements for Non-regenerative Drives

On SCR Module	SCR	Measure from	To	Nominal Meter Reading
01	01	Pin 6	Pin 7	5...20 Ω ⁽¹⁾
	04	Pin 5	Pin 4	
02	02	Pin 6	Pin 7	
	05	Pin 5	Pin 4	
03	03	Pin 6	Pin 7	
	06	Pin 5	Pin 4	

(1) The actual reading varies depending upon the SCR manufacturer. Verify that the actual measured value is consistent for all SCRs.

Figure 14 - SCR Connection Pinouts for Non-regenerative Drives



Check the Pulse Transformer Board

The armature-pulse transformer circuit board contains an isolated gate firing circuit and also provides dv/dt protection for the armature SCR modules. One of the following can indicate a malfunction of these modules:

- An Overcurrent fault (F13)
- Blown or tripped incoming protection devices

- Erratic motor operation

If a malfunction in this circuitry is suspected, follow these steps.

1. Read the General Safety Precautions on page 9.
2. Remove power from the drive (see page 47).
3. Remove the protective covers from the drive (see page 47).
4. Remove the control EMI shield and control board (see page 64).
5. Remove the slotted air flow plate from the top of the drive.
 - For a 38 A/10 Hp or 55 A/15 Hp drive with 230V AC input and 35 A/20 Hp, 45 A/25 Hp, and 52 A/30 Hp drives with 460V AC input, remove the four screws that secure the slotted air flow plate to the top of the drive, remove the fan cable from connector XV on the switching power supply board and remove the plate.

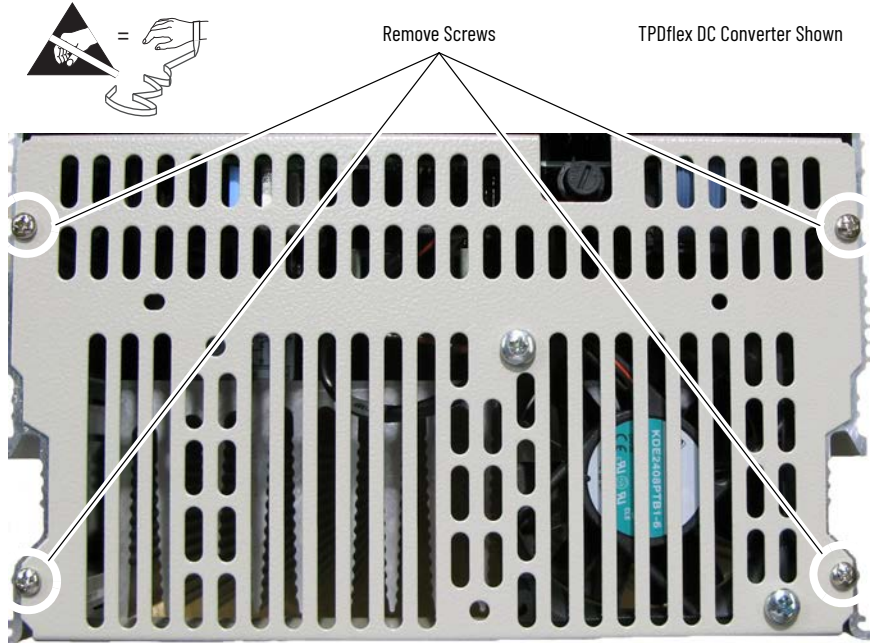

- For all other drives, remove the two screws that secure the slotted air flow plate to the top of the drive and remove the plate.



Remove Screw

Air flow Plate

Remove Screw

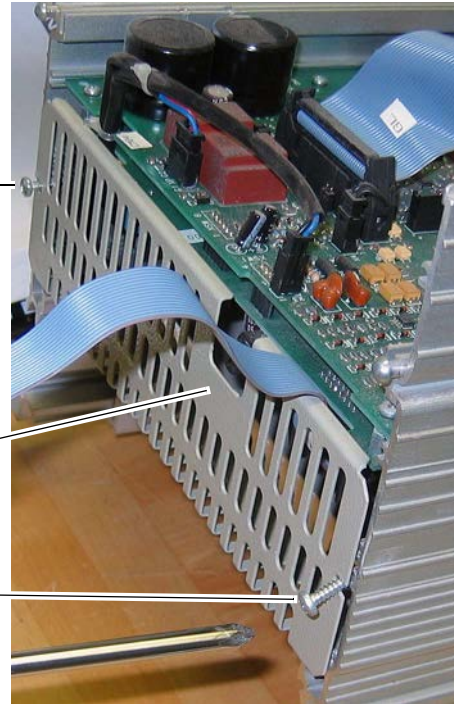

TPDflex DC Converter Shown

IMPORTANT Mark all connections and wires before removal to avoid incorrect wiring during reassembly.

6. Remove the pulse transformer board. See Pulse Transformer and Switching Power Supply Circuit Boards Replacement on page 67. The switching power supply board is mounted on the back of the pulse transformer board but does not need to be removed from the pulse transformer board for this test.
7. With a digital multimeter set for a “continuity check”, measure each connection point on the pulse transformer board that is listed in these tables. See Figure 27 on page 119 for connector locations. If any of the actual measurements are out of tolerance, replace the pulse transformer board.

Table 5 - Armature Pulse/ Snubber Circuit Measurements for Regenerative Drives

For SCR	Measure from...	To...	Meter Reading	Connector XY Pinout
1	KG1	XY-4	"open circuit"	
4	KG4	XY-1		
2	KG2	XY-5		
5	KG5	XY-2		
3	KG3	XY-6		
6	KG6	XY-3		
01	KG01	XY-1		
04	KG04	XY-4		
02	KG02	XY-2		
05	KG05	XY-5		
03	KG03	XY-3		
06	KG06	XY-6		

Table 6 - Armature Pulse/Smubber Circuit Measurements for Non-regenerative Drives

For SCR	Measure from...	To...	Meter Reading	Connector XY Pinout
01	KG01	XY-1	"open circuit"	
04	KG04	XY-4		
02	KG02	XY-2		
05	KG05	XY-5		
03	KG03	XY-3		
06	KG06	XY-6		

- With the digital multimeter set to "diode test", measure each connection point on the pulse transformer board that is listed in these tables. If any of the actual measurements are out of tolerance, replace the pulse transformer board.

Table 7 - Armature Pulse Transformer Primary Measurements for Regenerative and Non-regenerative Drives



For SCR	(+) Meter Lead	(-) Meter Lead	Meter Reading	Connector XY Pinout
1/01	XY-8	XY-1	0.41 Ω	
4/04	XY-8	XY-4		
2/02	XY-8	XY-2		
5/05	XY-8	XY-5		
3/03	XY-8	XY-3		
6/06	XY-8	XY-6		

Table 8 - Armature Pulse Transformer Primary Measurements for Regenerative Drives

For SCR	(+) Meter Lead	(-) Meter Lead	Meter Reading	Connector XY Pinout
1	XY-7	XY-1	0.41 Ω	
4	XY-7	XY-4		
2	XY-7	XY-2		
5	XY-7	XY-5		
3	XY-7	XY-3		
6	XY-7	XY-6		

Check the Field SCR/Dual Diode Module (Drives Only)

The field supply consists of a dual pack SCR/Dual Diode module that is arranged in a single-phase full wave rectifier configuration. Malfunction of either of these components can cause various responses including field and velocity-related faults, or blown fuses. The following procedures can be used if field bridge malfunctions are suspected.

- Read the General Safety Precautions on page 9.
- Remove power from the drive (see page 43).
- Verify that contactor power (if used) is removed.
- Verify that power to an external field supply (if used) is removed.
- Disconnect the field wires from C1 and D1. See Figure 10 on page 35.
- Check the anode to cathode junction of the field SCR/dual diode module. With the digital multimeter set to "diode test", measure the resistance across the modules. See Table 9 on page 35 and Figure 10 on page 35.

If a low resistance is detected, replace the modules. See Field SCR/Dual Diode Module and Field Circuit Board Replacement on page 88.

If a measurement results in an "infinity" reading, check the fuses at FV1 and FU1 on the bottom of the drive to determine if they are open. See Figure 10 on page 35.

Table 9 - SCR/Dual Diode Module Anode to Cathode Junction Measurements

(+) Meter Lead Terminal	(-) Meter Lead Terminal	Nominal Meter Reading
U1	C1	open or infinity
U1	D1	open or infinity
V1	C1	open or infinity
V1	D1	open or infinity
C1	D1	open or infinity
C1	U1	open or infinity
C1	V1	open or infinity
D1	C1	0.5V
D1	U1	0.5V
D1	V1	0.5V

Table 10 - Field Terminal Block and Field Fuse Locations

Bottom View of Drives

Drive with no Fan on Bottom

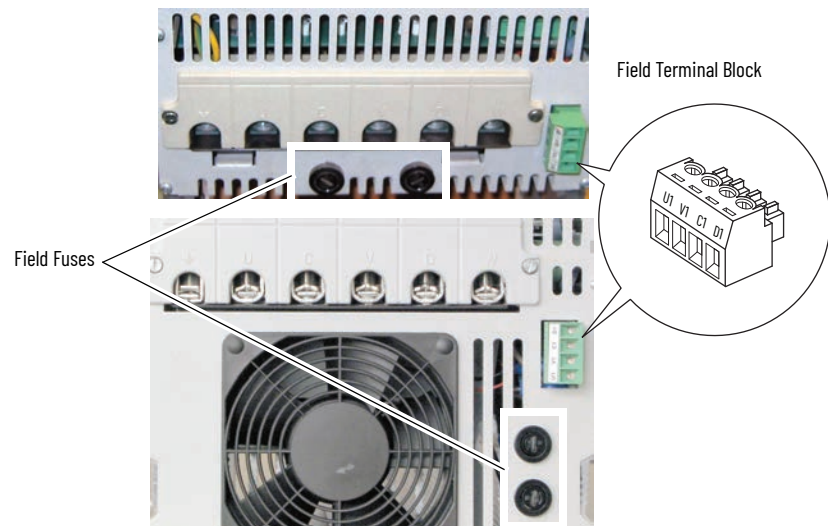

Drive with Fan on Bottom

- Remove the cable from connector XP on the pulse transformer circuit board.
- Check the gate cathode junction of the field SCR/dual diode module. With the digital multimeter set to "diode test" measure the resistance across the modules (lead orientation is not critical). See [Table 11](#). If a low resistance is detected, replace the SCR/dual diode module.

Table 11 - SCR/Dual Diode Module, Gate Cathode Junction Measurements

Measure from...	To...	Nominal meter Reading:
XP1	XP2	10...20 Ω
XP3	XP4	

Speed Feedback Device Tests

Complete the appropriate test for the feedback device installed.

Check the Encoder

The encoder feedback device provides a dual-channel quadrature output waveform and requires differential line-driver output at +5 or +12...15V signal levels. DIP switch S21 on the control board controls the encoder power supply voltage and input selection. See "DIP Switch and Jumper Settings" in the TPDflex DC Converters User Manual, publication 1S7TFLEXUM0). The encoder power supply from the drive can be measured from +V (+) to

COM (-) with a digital multimeter. When S21 is set to ENC_5, the voltage level range is +2.5...5.4V. When S21 is set to ENC_12, the voltage level range is +5.4V...15.2V. For reference, see [Figure 22](#) on page [116](#) for a schematic diagram.

The Channel A and Channel B are square wave type outputs that are 90° out of phase. When rotating in the CCW direction, as viewed from the commutator end, Channel A leads Channel B. Each differential channel has an inverted and non-inverted signal.

Power for the encoder is provided internally. The power source provides up to 200 mA of current with a current foldback feature. If the current draw exceeds 200 mA, the current foldback feature protects the power supply. If different power supply requirements exist for the chosen feedback device, the supply must be provided external to the drive.

The frequency is proportional to speed and the pulse rate of the encoder, referred to as the "Pulse/Rev" rating on the nameplate. You can calculate the speed of the motor as:
 Speed (RPM) = [Frequency (Hz) x 60]/[Pulses/Revolution].

Check the DC Tachometer

- Verify that DIP switch S4 on the control board is set to the correct input voltage of the DC analog tachometer. See "DIP Switch and Jumper Settings" in the TPDFlex DC Converters User Manual, publication 1S7TFLEXUM0). Also, see [Figure 23](#) on page [117](#) for a circuit diagram.
- The analog tachometer signal is fine scaled using parameter 562 [Anlg Tach Gain].
- See "Drive Reference and Feedback Scaling" in Appendix C of the TPDFlex DC Converters User Manual, publication 1S7TFLEXUM0) for more information.

Check the Resolver Interface Board

The resolver feedback option module uses the resolver feedback board for resolver connections, and the resolver interface board for external power, status, feedback board reset, and encoder output connections.

If a "Resolver Error" (F93) fault occurs and the resolver wiring and configuration are correct, the light-emitting diodes (LEDs) and testpoints on the resolver interface board can be used to verify that the board is not damaged.

- Verify that the following LEDs are functioning as expected. See [Figure 15](#) on page [37](#) for LED locations and switch settings.

LED Code	LED Color	On State	Off State
D3	Red	24V overload (fuse F1 blown). This fuse is self-resetting when it returns to normal operating temperature.	24V supply is OK.
D10	Green	12V supply is OK.	Loss of 12V power.
D11	Green	Resolver feedback board voltage is OK.	Voltage error on resolver feedback board.
D12	Blue	Switch S1 is set to +24V for encoder signal output on TB2.	S1 is <u>not</u> set for +24V.
D16	Yellow	Switch S1 is set to +12V for encoder signal output on TB2.	S1 is <u>not</u> set for +12V.
D18	Green	Switch S1 is set to +5V for encoder signal output on TB2.	S1 is <u>not</u> set for +5V.
D26	Red	Resolver feedback board is in reset mode.	Resolver feedback board <u>not</u> in reset mode.

If any of the applicable LEDs fail to turn on when control power is applied, verify that the resolver interface and resolver feedback boards are properly seated on the appropriate connectors (XRE, P2, P3). If problems persist, replace the resolver interface and/or resolver feedback board.

- Measure the signal voltage at the testpoints as indicated in the following table. See [Figure 15](#) on page [37](#) for testpoint locations.

Testpoint	to	Testpoint	Measurement
+12V	...	OV12	12V DC ±5%
-12V	...	OV12	-12V DC ±5%
+24V_VI	...	OV24	24V DC ±5%
+5V	...	OV5	5V DC ±5%

If any of the voltage measurements fails, replace the resolver interface board.

Figure 15 - Resolver Interface Board - Testpoint Locations

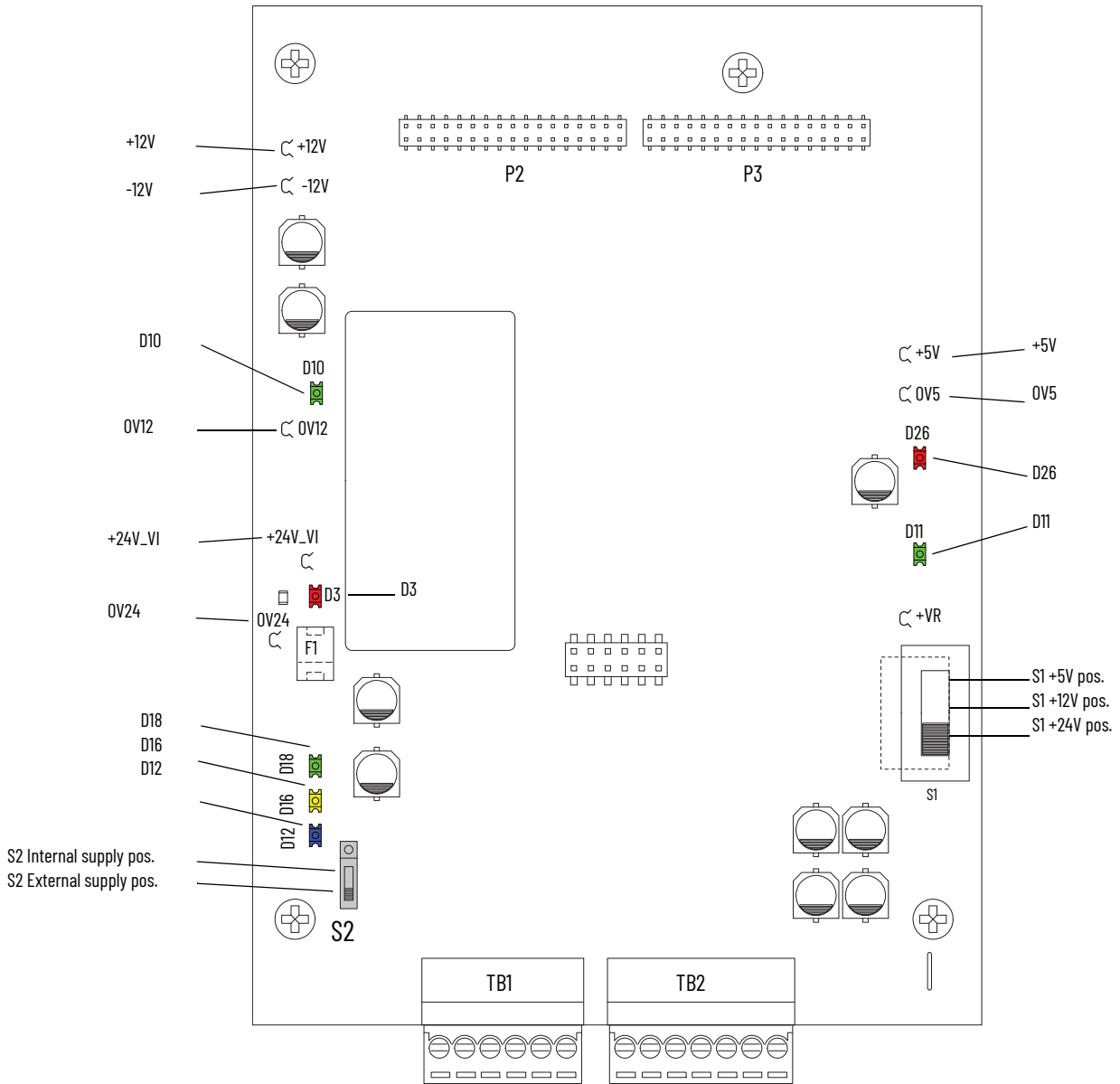

Thermistors and Thermal Switches

An external, user-supplied thermistor (PTC) or thermal switch can detect motor overheating. The PTC or thermal switch must be connected to terminals 78 and 79 on the control power terminal block on the pulse transformer circuit board. See [Figure 27](#) on page [119](#) for terminal block location.

A “Motor Over Temp” fault (F16) or alarm typically identifies an overheating motor.

- See Fault Descriptions in the TPDflex DC Converters User Manual, publication 1S7TFLEXUM0) for details.
- See [Figure 24](#) on page [117](#) for a circuit diagram.

Verify that the PTC or thermal switch is correctly configured:

- If a thermal switch is used, a 1 k Ω resistor must be placed in series between the switch and either terminal 78 or 79.
- If a thermistor (PTC) or thermal switch is not installed, a 1 k Ω resistor must be connected between terminals 78 and 79.

A bimetal thermostat that is installed directly on the heat sink monitors the drive heat sink temperature. When the heat sink temperature is too high, a “Heatsink OvrTemp” fault (F8) occurs.

- See Fault Descriptions in the TPDflex DC Converters User Manual, publication 1S7TFLEXUM0) for details.
- See [Figure 25](#) on page [118](#) for a circuit diagram.

During normal operation, 1.6V DC is present between terminal 78 and drive common. When an open circuit exists between terminals 78 and 79, 24V DC will be present at terminal 78 to drive common. If the 24V is missing, the pulse transformer board can need replacement.

Relay Outputs

Terminals 35 and 36 and 75 and 76 are N.O. relay outputs. The relay output between terminals 35 and 36 is configured with parameter 1392 [Relay Out 1 Sel]. The relay output between terminals 75 and 76 is configured with parameter 629 [Relay Out 2 Sel]. See Using Contactors in the TPDflex DC Converters User Manual, publication 1S7TFLEXUM0) for more information.

The “Main Contactor” fault (F10) indicates a problem that is related to a contactor used with the drive. See Fault Descriptions in the TPDflex DC Converters User Manual, publication 1S7TFLEXUM0) for details.

Create a Fault Report

A Technical Support wizard is available in the DriveExecutive and Connected Components Workbench software application. The wizard gathers information about the hardware, firmware, non-default parameters, and the fault and alarm queues, including time stamps. The logged data can be saved as a text (.txt) file.

Complete fault reports are critical for analysis and repair of modules that are returned to the factory. At a minimum, perform and record the following:

- Record the contents of the fault queue (faults and times of occurrence).
- Make a record of any burn marks on the printed circuit boards, cabling, bus bars, and SCR modules.
- Make a record of any liquid and condensation marks on the printed circuit boards, components, and mechanical parts.
- Make a record of the amount of dust and other additional particles on the drive and drive components.
- Make a record of any mechanical damage to the drive and drive components.
- Record the size and type of main fuses.
- Record any other important marks and damage.

What You Need When You Call Tech Support

When you contact Technical Support, please be prepared to provide the following information:

- Order number
- Product catalog number and drive series number (if applicable)

- Product serial number
- Firmware revision level
- Most recent fault code
- Your application

You can use this table to record the data that are provided in each TPDflex parameter listed.

Parameter Number	Parameter Name	Description	Parameter Data
1349	Status1 at Fault	Captures and displays Par 381 [Drive Status 1] bit pattern at the time of the last fault.	
1350	Status2 at Fault	Captures and displays Par 382 [Drive Status 2] bit pattern at the time of the last fault.	
1351...1360	Fault x Code	A code that represents the fault that tripped the drive. The codes will appear in these parameters in the order they occur (for example, [Fault 1 Code] = the most recent fault).	
1361...1370	Fault x Time	The time between initial drive power-up and the occurrence of the associated trip fault.	
1371	Fault Arm Amps	Captures and displays the armature current (as a percentage of rated current) at the time of the last fault.	
1372	Fault Speed	Captures and displays the output speed (rpm) of the drive at the time of the last fault.	
1373	Fault Field Amps	Captures and displays the field current (as a percentage of rated current) at the time of the last fault.	
1374	Fault Voltage	Captures and displays the armature voltage at the time of the last fault.	

Notes:

Part Replacement Procedures

Topic	Page
Replacement Part Kits	41
Remove Power from the Drive	43
Switching Power Supply Fuse Replacement	44
Field Circuit Fuse Replacement	44
DPI / HIM Assembly Replacement	45
Protective Cover Replacement	47
Communication Adapter and EMI Shield Replacement	49
Resolver Feedback and Interface Circuit Board Replacement	52
I/O Expansion Circuit Board Replacement	56
115V AC to 24V DC I/O Converter Circuit Board Replacement	58
Control Circuit Board Replacement	59
Control EMI Shield and Control Circuit Board Replacement	64
Pulse Transformer and Switching Power Supply Circuit Boards Replacement	67
AC Current Transducer Replacement	79
Power Traces Circuit Board Replacement	85
Field SCR/Dual Diode Module and Field Circuit Board Replacement	88
Bimetal Thermostat Replacement	94
SCR Module Replacement	95
Cooling Fan Replacement	103

This chapter provides a list of spare part kits and detailed procedures for removing and replacing drive components.

Replacement Part Kits

[Table 12](#) lists the spare parts kits available for TPDflex DC frame A drives.

Table 12 - Spare Part Kits

Description	Kit Cat. No.	Instructions Page
Fuses		
Switching Power Supply Board (Revision H and Lower) Fuse - Ferrule 5 x 20 mm, 1 A 250V	SK-20P-S8B28	44
Switching Power Supply Board (Revision I and Higher) Fuse - Ferrule 5 x 20 mm, 2.5 A 250V	SK-20P-S8B29	
Switching Power Supply Board Fuse Holder	SK-20P-S7G84	44
Field Circuit Fuses (Qty 2) - Ferrule 6 x 32 mm, 16 A 500V	SK-20P-S824B	44
Field Circuit Fuse Holder	SK-20P-S8N04	44
Accessories		
DPI / HIM Assembly	SK-DC1-CVR1-A1	45
Upper Cover	SK-20P-S75BT	47
Lower Cover	SK-20P-S77BT	47
Control Circuit Boards		
Resolver Feedback and Interface Boards	20P-RES-A0	52
I/O Expansion Board (TBO-32)	20P-S5V62	56
115V AC to 24V DC I/O Converter Board	20P-S520L	58

Table 12 - Spare Part Kits (Continued)

Description	Kit Cat. No.	Instructions Page
Control Circuit Board	SK-20P-S5RP1	59
Power Circuit Boards		
Pulse Transformer Board for 230V AC Regen. Drive, 7...29 A (FIR-41)	SK-20P-S5N02	67
Pulse Transformer Board for 230V AC Regen. Drive, 38...110 A (FIR-42)	SK-20P-S5N07	
Pulse Transformer Board for 460/480V AC Regen. Drive, 4.1...27 A (FIR-51)	SK-20P-S5N12	
Pulse Transformer Board for 460/480V AC Regen. Drive, 35...129 A (FIR-52)	SK-20P-S5N17	
Pulse Transformer Board for 460/480V AC Non-Regen. Drive, 4.1...27 A (FIR-51-2B)	SK-20P-S5N40	
Pulse Transformer Board for 460/480V AC Non-Regen. Drive, 35...129 A (FIR-52-2B)	SK-20P-S5N41	
Switching Power Supply Board (SW1-31)	SK-20P-S5N03	67
Power Traces Board for 230V AC Regen. Drive, 7...55 A (PBB-4B)	SK-20P-S5H95	85
Power Traces Board for 460/480V AC Regen. Drive, 4.1...52 A (PBB-4B)		
Power Traces Board for 460/480V AC Non-Regen. Drive, 4.1...52 A (PBB-2B)		
Field Board (PFC1A-32)	SK-20P-S5N24	88
Power Components		
AC Current Transducers (Qty 2), 200 A / 0.1 A	SK-20P-S78H0	79
15 A Field SCR/ Dual Diode Module for 230V AC Regen. Drive, 7...29 A	SK-20P-S79F3	88
15 A Field SCR/ Dual Diode Module for 460/480V AC Regen. or Non-Regen. Drive, 4.1...27 A		
28 A Field SCR/Dual Diode Module for 230V AC Regen. Drive, 38...110 A	SK-20P-S79F1	88
28 A Field SCR/Dual Diode Module for 460/480V AC Regen. or Non-Regen. Drive, 35...129 A		
Bimetal Thermostat 85 °C ±3 °C for 230V AC Drive, 38...73 A	SK-20P-S7G37	94
Bimetal Thermostat 85 °C ±3 °C for 460/480V AC Drive, 35...73 A	SK-20P-S7GA1	
Bimetal Thermostat 80 °C ±3 °C for 230V AC Drive, 93...110 A		
Bimetal Thermostat 80 °C ±3 °C for 460/480V AC Drive, 100...129 A		
Bimetal Thermostat 70 °C ±3 °C for 460/480V AC Drive, 86 A	SK-20P-S7GA0	

Table 12 - Spare Part Kits (Continued)

Description	Kit Cat. No.	Instructions Page
SCR Modules (Qty 6) 1K2V 25 A for 230V AC Regen. Drive, 7...20 A	SK-20P-S7F44	95
SCR Modules (Qty 6) 1K2V 40 A for 230V AC Regen. Drive, 29...55 A	SK-20P-S7F45	
SCR Modules (Qty 6) 1K6V 25 A for 460/480V Regen. Drive, 4.1...19 A	SK-20P-S7F73	
SCR Modules (Qty 3) 1K6V 25 A for 460/480V Non-Regen. Drive, 4.1...19 A		
SCR Modules (Qty 6) 1K6V 40 A for 460/480V Regen. Drive, 27...52 A	SK-20P-S7F74	
SCR Modules (Qty 3) 1K6V 40 A for 460/480V Non-Regen. Drive, 27...52 A		
SCR Modules (Qty 6) 1K2V 55 A for 230V AC Regen. Drive, 73 A	SK-20P-S7F46	
SCR Modules (Qty 6) 1K2V 90 A for 230V AC Regen. Drive, 93...110 A	SK-20P-S7F47	
SCR Modules (Qty 6) 1K6V 55 A for 460/480V Regen. Drive, 73...86 A	SK-20P-S7F75	
SCR Modules (Qty 3) 1K6V 55 A for 460/480V Non-Regen. Drive, 73...86 A		
SCR Modules (Qty 6) 1K6V 90 A for 460/480V Regen. Drive, 100...129 A	SK-20P-S7F77	
SCR Modules (Qty 3) 1K6V 90 A for 460/480V Non-Regen. Drive, 100...129 A		
Ventilation Components		
Cooling Fan, 37 CFM, for 230V AC Drive 38 A and 55 A, 460/480V AC Drive 35...52 A	SK-20P-S7G76	103
Cooling Fan, 100 CFM, for 230V AC and 460/480V AC Drives 73 A and Higher	SK-20P-S7G71	

Remove Power from the Drive



ATTENTION: Remove power before making or breaking cable connections. When you remove or insert a cable connector with power applied, an electrical arc can occur. An electrical arc can cause personal injury or property damage by:

- sending an erroneous signal to your system field devices, causing unintended machine motion
- causing an explosion in a hazardous environment

Electrical arcing causes excessive wear to contacts on both the module and its mating connector. Worn contacts can create electrical resistance.

- Remove and lock-out all incoming power to the drive.

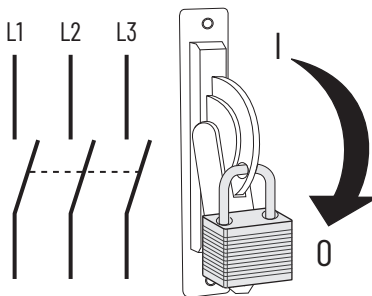

Switching Power Supply Fuse Replacement

Remove the Fuse on the Switching Power Supply Circuit Board

IMPORTANT For TPDflex DC Converters, the replacement fuse that is used for the switching power supply circuit board depends on the revision of the board. See the Fuses section in the Spare Part Kits table on page [41](#) for details.

Follow these steps to remove the fuse on the switching power supply circuit board.

1. Read the General Safety Precautions on page [9](#).
2. Remove power from the drive (see page [43](#)).
3. The fuse is on the top of the drive. Insert a screwdriver in the slot on the top of the fuse holder, carefully push down, and turn the fuse counterclockwise. When the fuse holder releases, remove the holder and fuse.

Top View of Drive

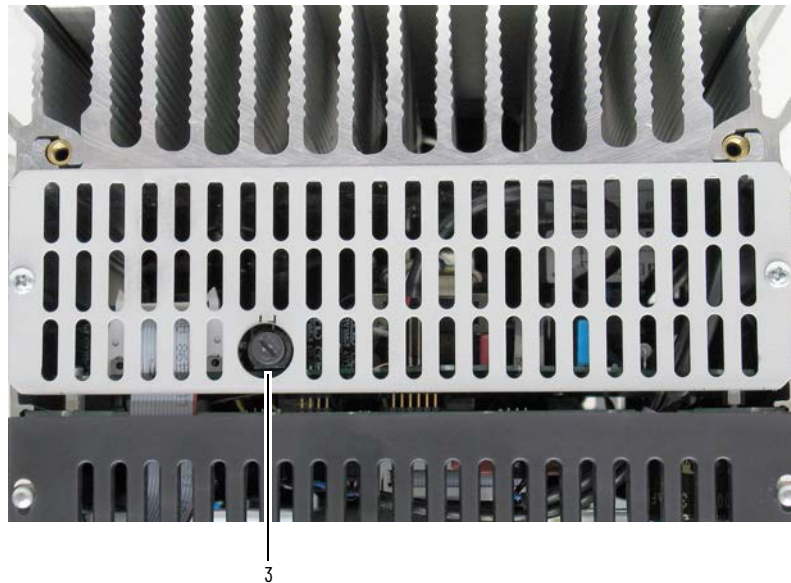

Install the Fuse on the Switching Power Supply Circuit Board

Install the fuse on the switching power supply board in reverse order of removal.

Field Circuit Fuse Replacement

Remove the Field Circuit Fuses

Follow these steps to remove the field circuit fuses.

1. Read the General Safety Precautions on page [9](#).
2. Remove power from the drive (see page [43](#)).

3. The fuse is on the bottom of the drive. Insert a screwdriver in the slot on the top of the fuse holder, carefully push down, and turn the fuse counterclockwise. When the fuse holder releases, remove the holder and fuse.

Bottom View of Drives

Drive with no Fan at Bottom

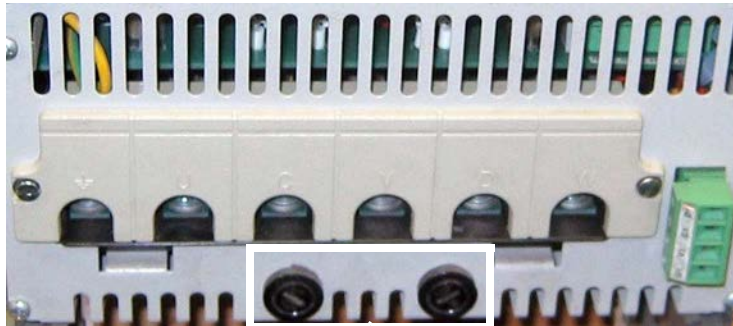

Drive with Fan at Bottom

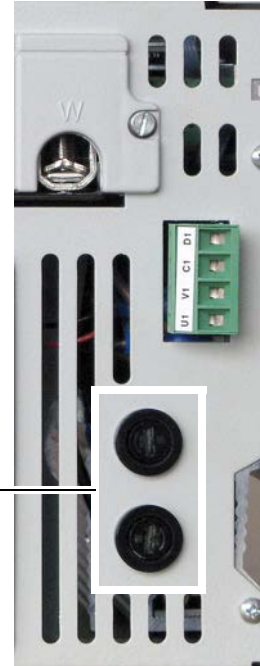

DPI / HIM Assembly Replacement

Install the Field Circuit Fuses

Install the field circuit fuses in reverse order of removal.

Remove the DPI / HIM Assembly from the Protective Cover

Follow these steps to remove the device peripheral interface (DPI)/ human interface module (HIM) assembly.

1. Read the General Safety Precautions on page [9](#).
2. Remove power from the drive (see page [43](#)).
3. Press downward on the tab at the top of the HIM assembly and, by pressing upward at the bottom, slide the HIM out of the cradle.
4. Disconnect the DPI cable from the HIM assembly.
5. Remove the screw that secures the DPI / HIM assembly to the drive.

- Carefully remove the DPI / HIM assembly from the cover and disconnect the cable from the connector on the back side of the assembly.

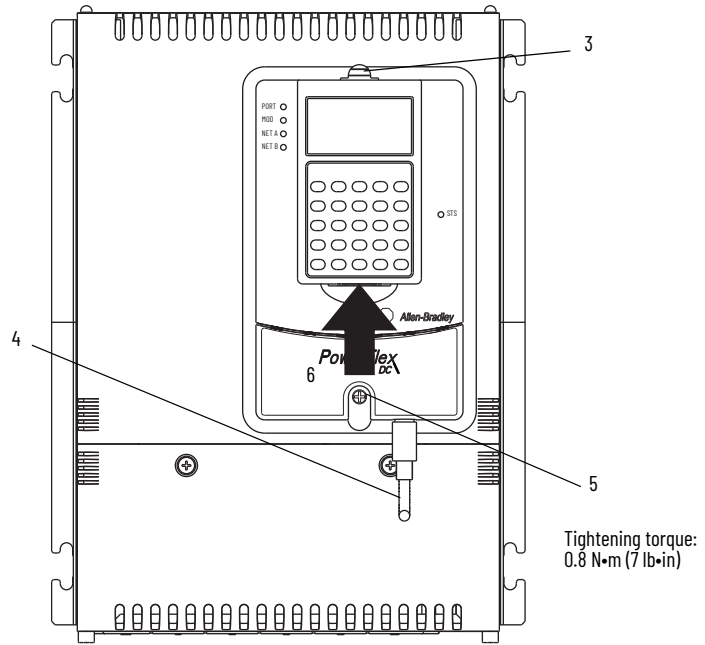

Install the DPI / HIM Assembly on the Protective Cover

Install the DPI / HIM assembly in reverse order of removal.

Protective Cover Replacement

Remove the Protective Covers

You must remove both the lower protective cover and the power terminal cover to access the power terminals. Follow these steps to remove the protective covers.

1. Read the General Safety Precautions on page [9](#).
2. Remove power from the drive (see page [43](#)).
3. Loosen the two screws that secure the power terminal cover to the drive and slide the cover down and off the chassis.

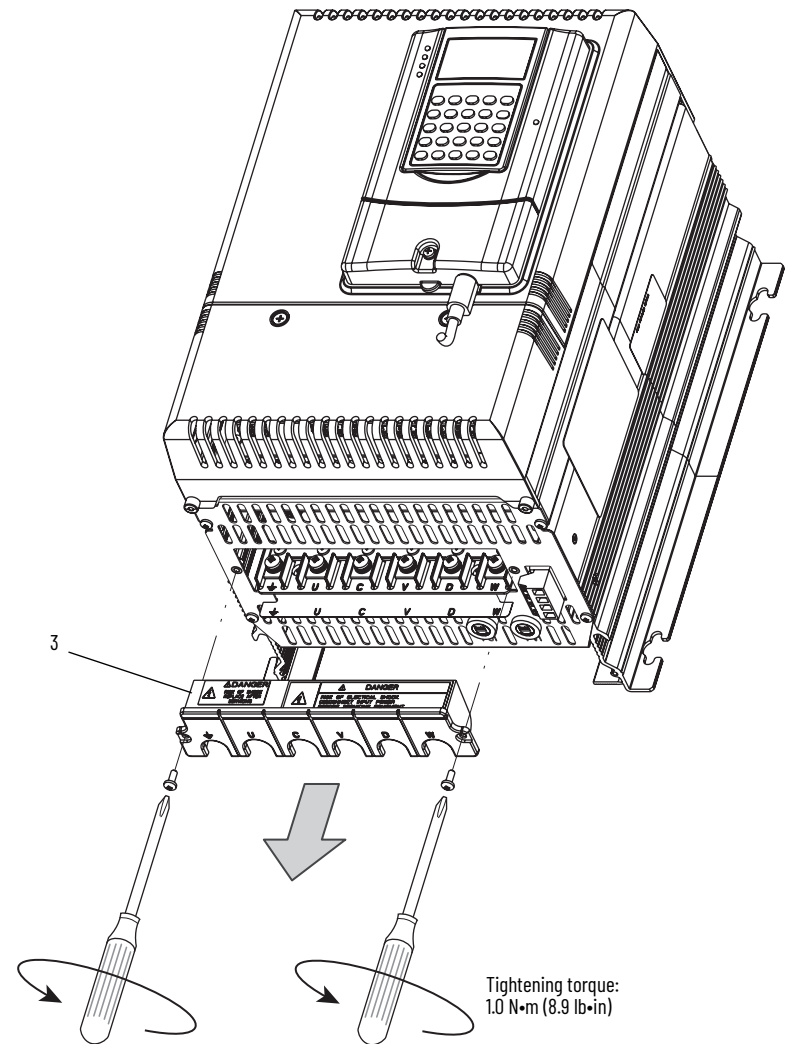

4. Disconnect the DPI cable from the HIM assembly.
5. Remove the two screws that secure the bottom protective cover to the drive.

- While gently lifting along the top edge of the cover, slide it down and off the drive chassis.

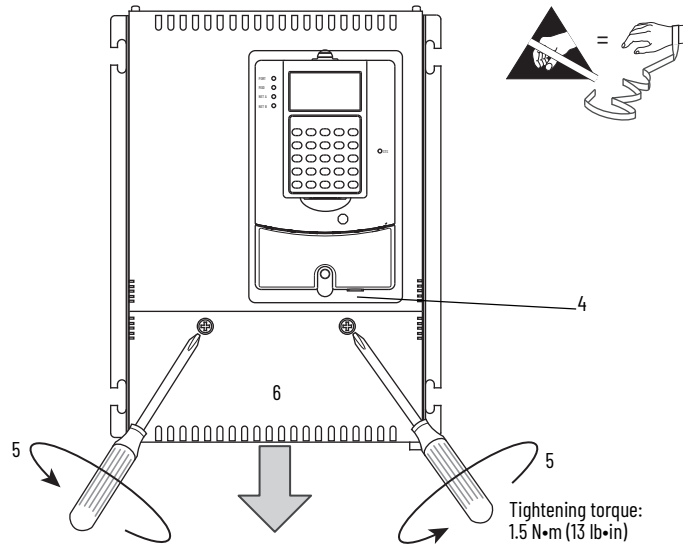

- Press in on the sides at the bottom edge of the top cover and simultaneously pull the cover toward you to pull it partially off the drive chassis.
- At the top of the drive, pull the cover away from the drive, until the pins fit in the keyhole in the top of the cover.
- Carefully lift the cover off the drive chassis.

IMPORTANT The HIM assembly is connected via a cable to the control board and therefore will not pull free from the drive until disconnected. See step 10 for instructions.

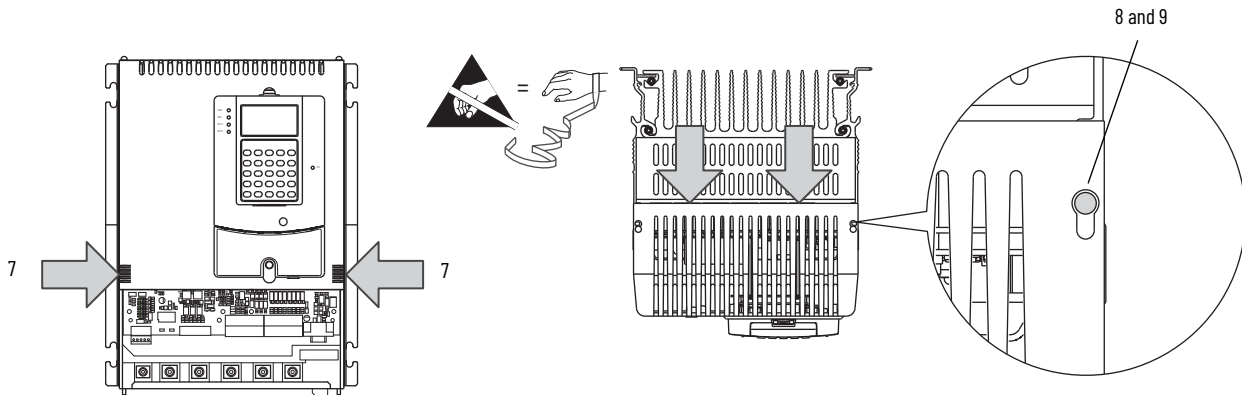

- Disconnect the HIM communication cable from the connector on the upper right corner of the control board and set the cover aside.



Install the Protective Covers

Install the protective covers in reverse order of removal.



ATTENTION: Risk of electric shock exists when power is applied to the power terminals of the drive. The power terminal cover and protective covers must be replaced after servicing the drive.

Communication Adapter and EMI Shield Replacement

Remove the Communication Adapter and EMI Shield

Follow these steps to communication adapter and EMI shield.

- Read the General Safety Precautions on page [9](#).
- Remove power from the drive (see page [43](#)).
- Disconnect the interface cable from the communication adapter and set it aside.
- Disconnect any network cables from the adapter and set them aside.

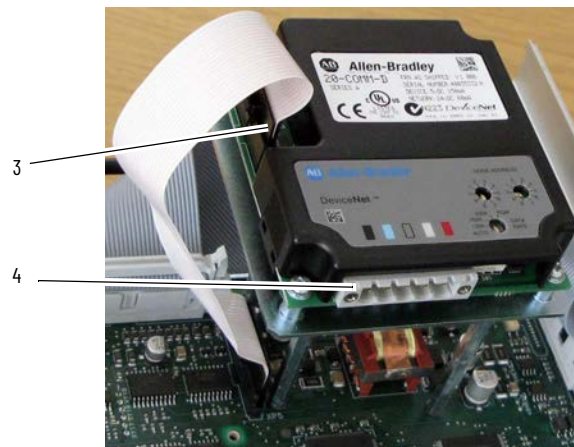

5. Remove the four screws that secure the communication adapter to the EMI shield and remove the adapter.

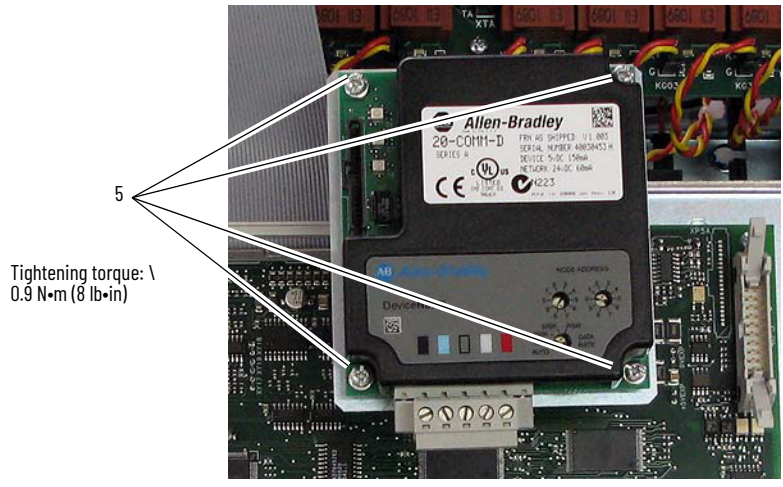

6. Remove the three screws that secure the EMI shield to the stand-offs on the control board and remove the EMI shield.

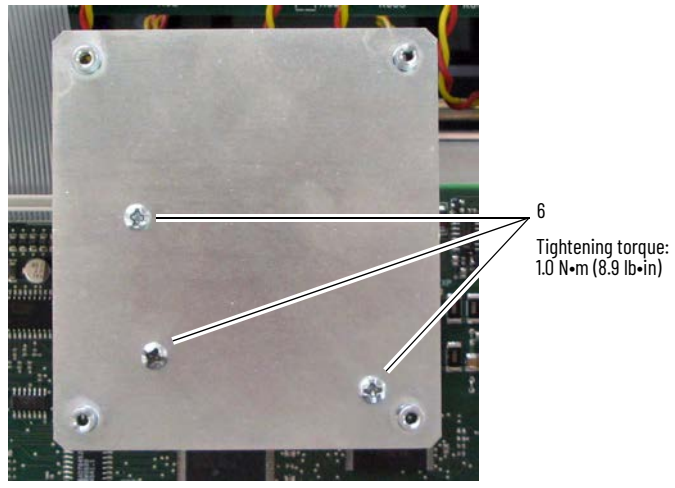

7. Remove the three stand-offs from the control board.

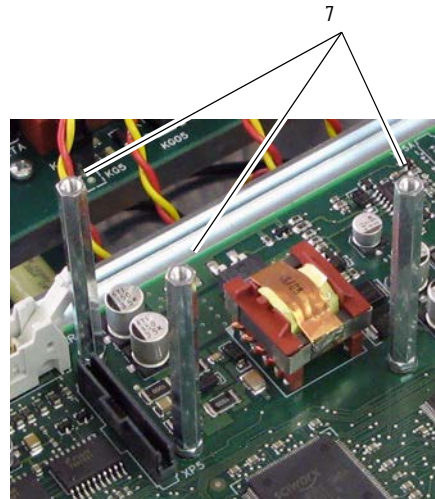

Tightening torque:
1.0 N•m (8.9 lb•in)

Install the Communication Adapter and EMI Shield

Install the communication adapter and EMI shield in reverse order of removal.

Resolver Feedback and Interface Circuit Board Replacement

Remove the Resolver Feedback and Interface Circuit Boards

Follow these steps to remove the resolver feedback and interface circuit boards.

1. Read the General Safety Precautions on page 9.
2. Remove power from the drive (see page 43).
3. Remove the protective covers (see page 47).

IMPORTANT Mark all connections and wires before removal to avoid incorrect wiring during reassembly.

4. Disconnect the plug-in terminal blocks from the resolver feedback and resolver interface boards.

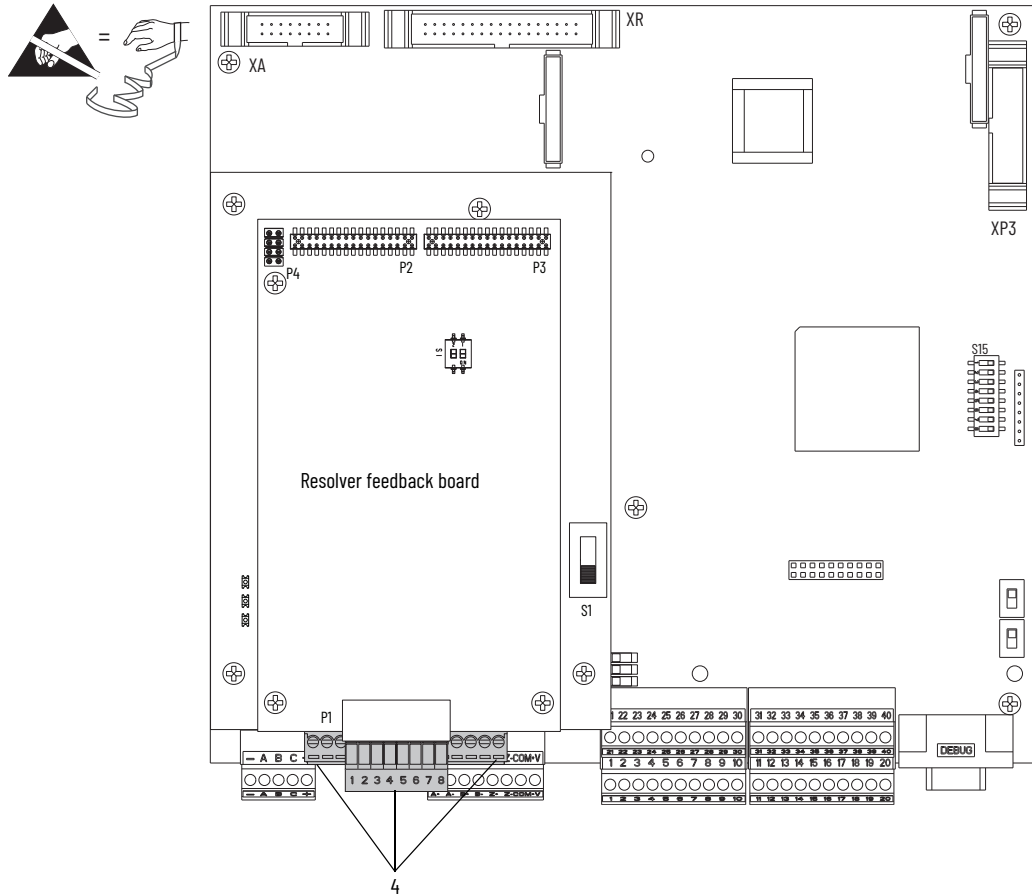

- Remove the three hexalobular screws that secure the resolver feedback board to the stand-offs on the resolver interface board and carefully remove the resolver feedback board.

IMPORTANT The resolver feedback board is connected to the resolver interface board below it via stacker connector pins at connectors P2 and P3. Lift the resolver feedback board straight up during removal to avoid any damage to the connector pins.

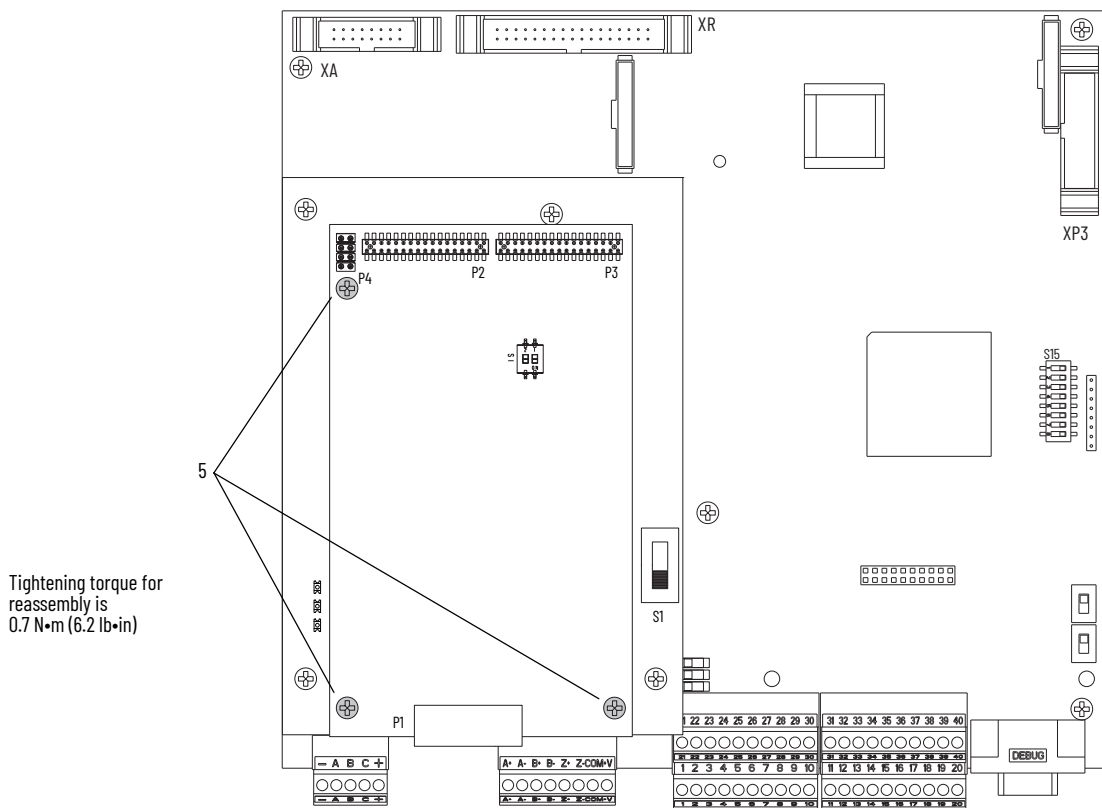

- Remove the three stand-offs from the resolver interface board.

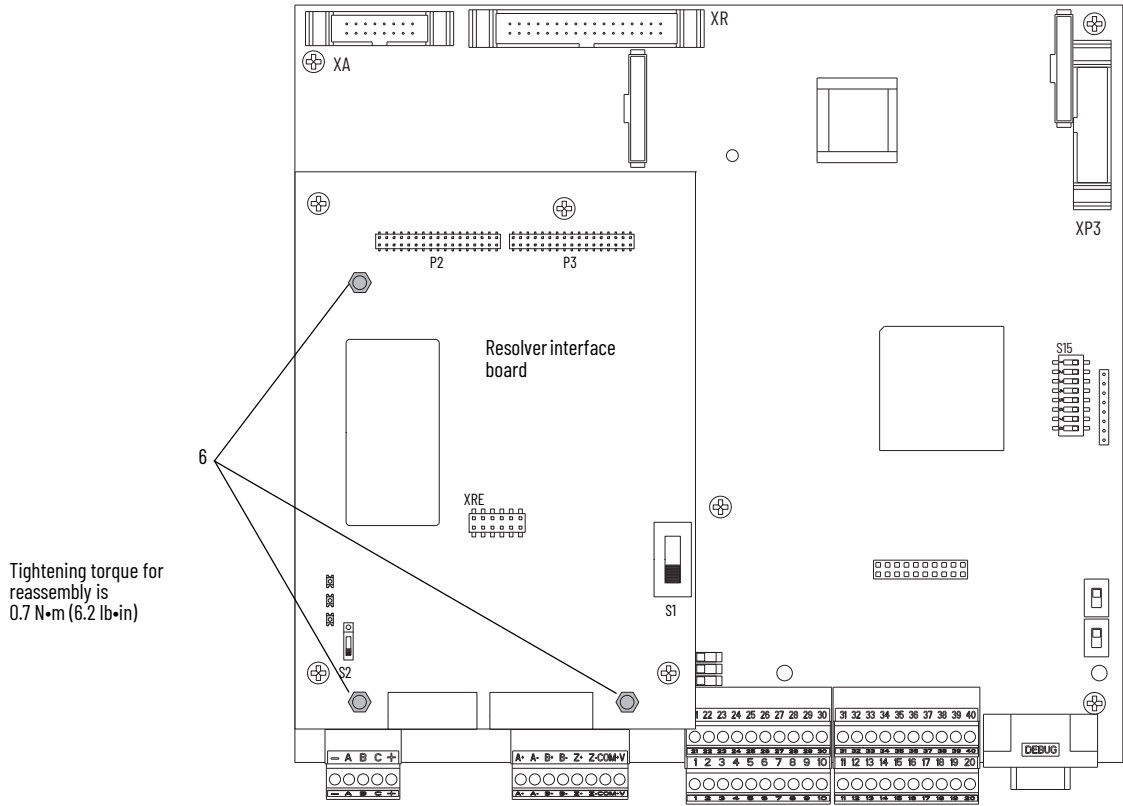

- 7. Remove the four hexalobular screws that secure the resolver interface board to the control board and remove the resolver interface board.

IMPORTANT The resolver interface board is connected to the control board below it via a stacker connector pin at connector XRE. Lift the resolver interface board straight up during removal to avoid any damage to the connector pin.

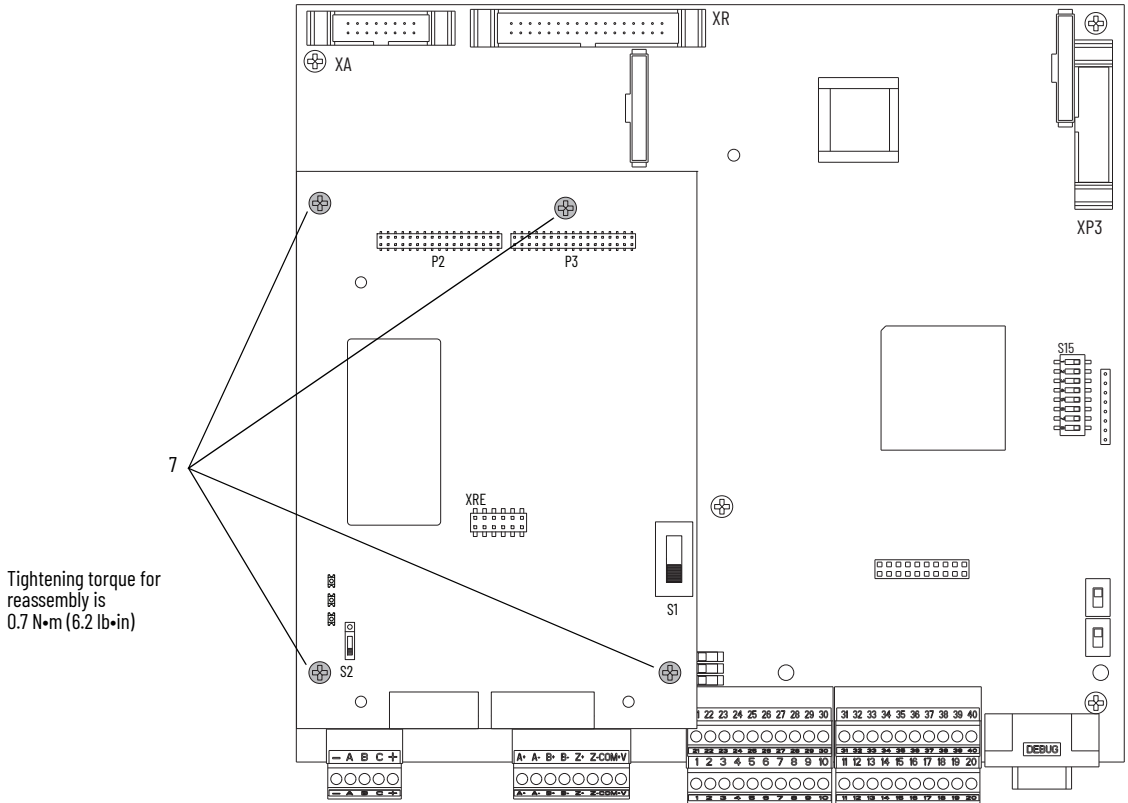

Install the Resolver Feedback and Interface Circuit Boards

Install the resolver feedback and interface boards in reverse order of removal.

I/O Expansion Circuit Board Replacement

Remove the I/O Expansion Circuit Board

Follow these steps to remove the I/O expansion circuit board.

1. Read the General Safety Precautions on page [9](#).
2. Remove power from the drive (see page [43](#)).
3. Remove the protective covers (see page [47](#)).
4. If installed, remove the resolver feedback option and interface boards (see page [52](#)).

IMPORTANT Mark all connections and wires before removal to avoid incorrect wiring during reassembly.

5. Remove the plug-in I/O terminal blocks with the wiring kept in place.
6. Remove the two M3 x 6 mm screws and washers that secure the I/O expansion board to the stand-offs on the control board.

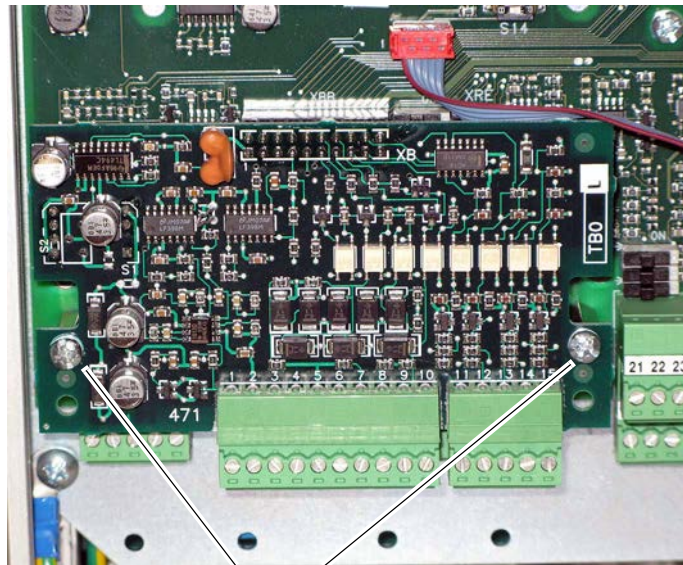

6

Tightening torque:
1.0 N·m (8.9 lb·in)

- 7. Carefully pull the I/O expansion board off connector XBB on the control board.
- 8. Remove the two stand-offs from the control board.

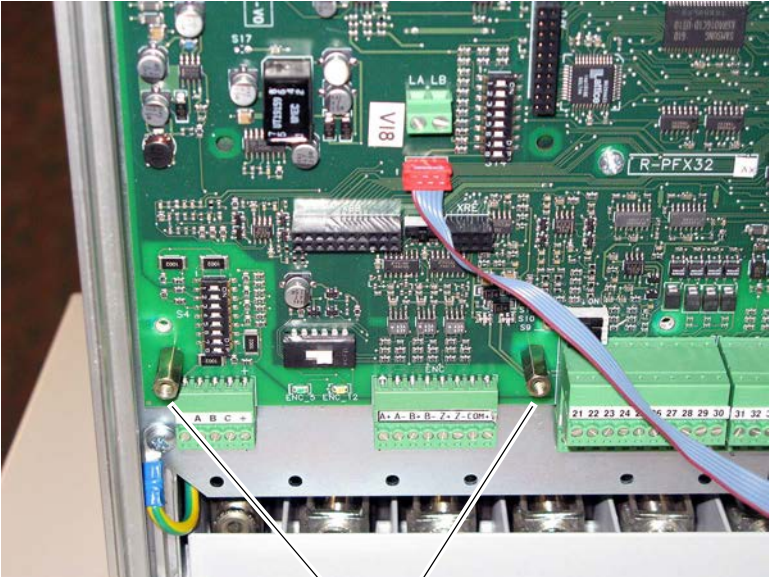

8 Tightening torque:
1.0 N·m (8.9 lb·in)

- 9. Install one of the existing screws in the lower left corner of the control circuit board.

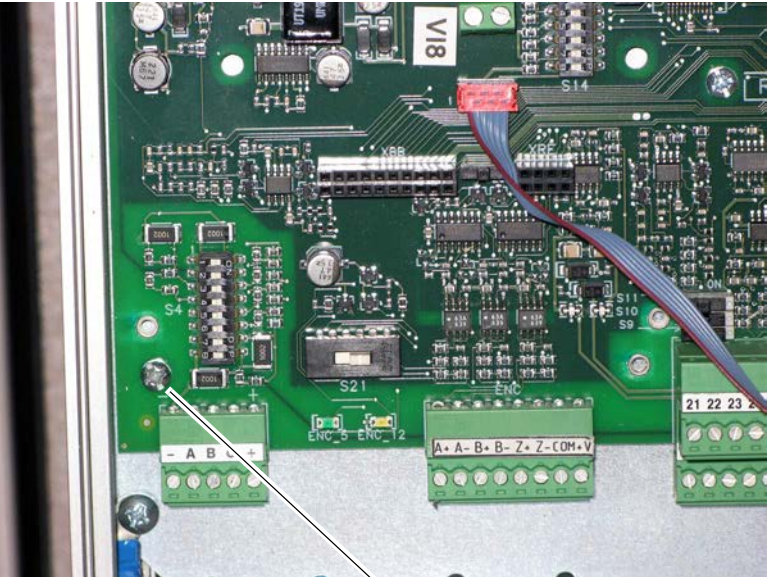

9 Tightening torque:
1.0 N·m (8.9 lb·in)

Install the I/O Expansion Circuit Board

Install the I/O expansion board in reverse order of removal.

115V AC to 24V DC I/O Converter Circuit Board Replacement

Remove the 115V AC to 24V DC I/O Converter Circuit Board

Follow these steps to remove the 115V AC to 24V DC I/O converter circuit board.

1. Read the General Safety Precautions on page 9.
2. Remove power from the drive (see page 43).
3. Remove the protective covers (see page 47).

IMPORTANT Mark all connections and wires before removal to avoid incorrect wiring during reassembly.

4. Remove the plug-in I/O terminal blocks with the wiring kept in place.
5. Remove the two M3 x 6 mm screws and washers that secure the I/O converter board to the stand-offs on the control board and remove the I/O converter board.

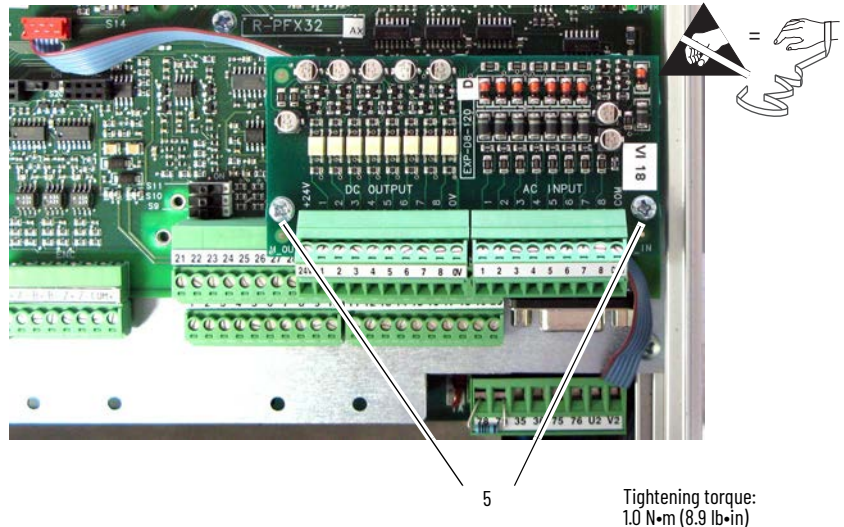

- Remove the two stand-offs from the control board.

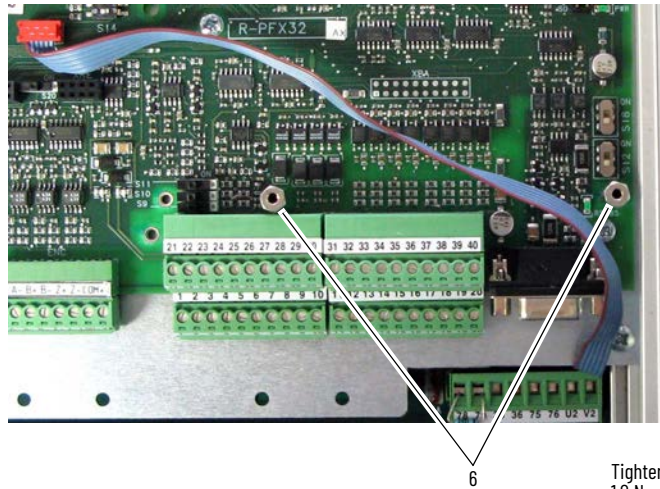

Tightening torque:
1.0 N•m (8.9 lb•in)

6

Install the 115V AC to 24V DC I/O Converter Circuit Board

Install the 115V AC to 24V DC I/O converter board in reverse order of removal.

Control Circuit Board Replacement

Remove the Control Circuit Board

Follow these steps to remove the control circuit board.





- Save the drive and adapter parameter configuration to a HIM Set or by downloading the drive and adapter parameters to an offline database file using DriveExecutive™. See the TPDflex DC Converters User Manual publication 1S7TFLEUMO for information on using the HIM. See the on-line Help provided with DriveExecutive for more information on HIM Sets or using the HIM.
- Read the General Safety Precautions on page [9](#).
- Remove power from the drive (see page [43](#)).
- Remove the protective covers (see page [47](#)).
- Remove the communication adapter and EMI shield from the control board (see page [49](#)).
- If installed, remove the I/O expansion circuit board (see page [56](#)).
- If installed, remove the 115V AC to 24V DC I/O converter circuit board (see page [58](#)).

- Record all switch and jumper settings on the control board. See the TPDflex DC Converters User Manual, publication 1S7TFLEXUM0 for more information.

Jumper Settings Series A

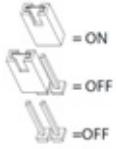
ID	Jumper Switch	Function	Factory Default	Example
1	S0	For factory boot flashing only. Leave set to the factory setting. Jumper On Firmware boot Jumper Off Normal function	Jumper Off	
	S1	For factory boot flashing only. Leave set to the factory setting. Jumper On Write firmware boot code Jumper Off Boot code on flash is protected	Jumper Off	
	S2	Not used. Leave set to the factory setting.	Jumper Off	
	S3	For factory boot flashing only. Leave set to the factory setting. Jumper On Reset Jumper Off Normal function	Jumper Off	
2	S4	Configures the input voltage of the DC analog tachometer. See Table 28 on page 80 for configuration.	90V	...
3	S9	Configures the input signal of Analog Input 1 (terminals 1 and 2): Position Off 0...20 mA / 4...20 mA Position On 0...10V / ±10V Par 71 [Anlg In1 Config] must be programmed to match the input signal type selected with this switch.	On	
	S10	Configures the input signal of Analog Input 2 (terminal 3 and 4): Position Off 0...20 mA / 4...20 mA Position On 0...10V / ±10V Par 76 [Anlg In2 Config] must be programmed to match the input signal type selected with this switch.	On	
	S11	Configures the input signal of Analog Input 3 (terminals 5 and 6): Position Off 0...20 mA / 4...20 mA Position On 0...10V / ±10V Par 81 [Anlg In3 Config] must be programmed to match the input signal type selected with this switch.	On	
4	S12	Not used. Leave set to the factory setting.	Off	...
5	S14	Field current resistors setting, see Field Current Configuration on page 62. The value that is selected with switch S14 must be entered in Par 374 [Drv Fld Brdg Cur] when the drive is commissioned. For permanent magnet motor or external field controller applications, leave set to the factory default settings.	Minimum field current rating based on the drive size.	...
6	S15	Configuration of the control circuit board to the appropriate drive size. Leave set to the factory setting, unless the control board has been supplied as a spare part. See DIP Switch S15 Settings on page 80 for switch configuration that is based on drive current rating code.	Armature current based on drive size.	...
7	S18	Not used. Leave set to the factory setting.	Off	...
8	S20	Monitoring (reported by Par 652 [Encoder Err Chk]) of the Z channel of the Digital Encoder on connector XE2. This switch adds/removes the Z channel in the encoder hardware check circuit. Par 652 enables/disables reading the result of that hardware check. Position Off Z channel monitored Position On Z channel not monitored	On	
9	S21	Encoder power supply voltage and input selection: This switch setting determines both the power supply (input) and feedback level (output) voltage of the connected encoder. When control power is supplied to the drive, the appropriate LED lights to indicate the selection of the switch. ENC_5 +5V encoder (2.5...5.4V input range) ENC_12 +12...15V encoder (+5.4V...15.2V input range)	12...15V	

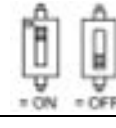
Jumper Settings Series B

ID	Jumper Switch	Function	Factory Default	Example
1	S0	Not used. Leave set to the factory setting.	Jumper Off	
	S1	Not used. Leave set to the factory setting.	Jumper Off	
	S2	For factory boot flashing only. Leave set to the factory setting. Jumper On Boot mode Jumper Off Normal function	Jumper Off	
	S3	For factory boot flashing only. Leave set to the factory setting. Jumper On Reset Jumper Off Normal function	Jumper Off	
2	S4	Configures the input voltage of the DC analog tachometer. See Table 28 on page 80 for configuration.	90V	...
3	S9	Configures the input signal of Analog Input 1 (terminals 1 and 2): Position On 0...20 mA / 4...20 mA Position Off 0...10V / ±10V Par 71 [Anlg In1 Config] must be programmed to match the input signal type selected with this switch.	Off	
	S10	Configures the input signal of Analog Input 2 (terminal 3 and 4): Position On 0...20 mA / 4...20 mA Position Off 0...10V / ±10V Par 76 [Anlg In2 Config] must be programmed to match the input signal type selected with this switch.	Off	
	S11	Configures the input signal of Analog Input 3 (terminals 5 and 6): Position On 0...20 mA / 4...20 mA Position Off 0...10V / ±10V Par 81 [Anlg In3 Config] must be programmed to match the input signal type selected with this switch.	Off	
4	S12	Not used. Leave set to the factory setting	Off	...
5	S14	Field current resistors setting, see Field Current Configuration on page 62. The value that is selected with switch S14 must be entered in Par 374 [Drv Fld Brdg Cur] when the drive is commissioned. For permanent magnet motor or external field controller applications, leave set to the factory default settings.	Minimum field current rating based on the drive size.	...
6	S15	Configuration of the control circuit board to the appropriate drive size. Leave set to the factory setting, unless the control board has been supplied as a spare part. See DIP Switch S15 Settings on page 80 for switch configuration that is based on drive current rating code.	Armature current based on drive size.	...
7	S18	Not used. Leave set to the factory setting.	Off	...
8	S20	Monitoring (reported by Par 652 [Encoder Err Chk]) of the Z channel of the Digital Encoder on connector XE2. This switch adds/removes the Z channel in the encoder hardware check circuit. Par 652 enables/disables reading the result of that hardware check. Position On Z channel monitored Position Off Z channel not monitored	Off	
9	S21	Encoder power supply voltage and input selection: This switch setting determines both the power supply (input) and feedback level (output) voltage of the connected encoder. When control power is supplied to the drive, the appropriate LED lights to indicate the selection of the switch. Position On +12...15V encoder (+5.4V...15.2V input range) Position Off +5V encoder (2.5...5.4V input range)	On (12...15 V)	

9. Carefully disconnect the cables from connectors XFGD, XA, and XR on the control board.
10. Remove the plug-in I/O and control terminal blocks with the wiring kept in place.

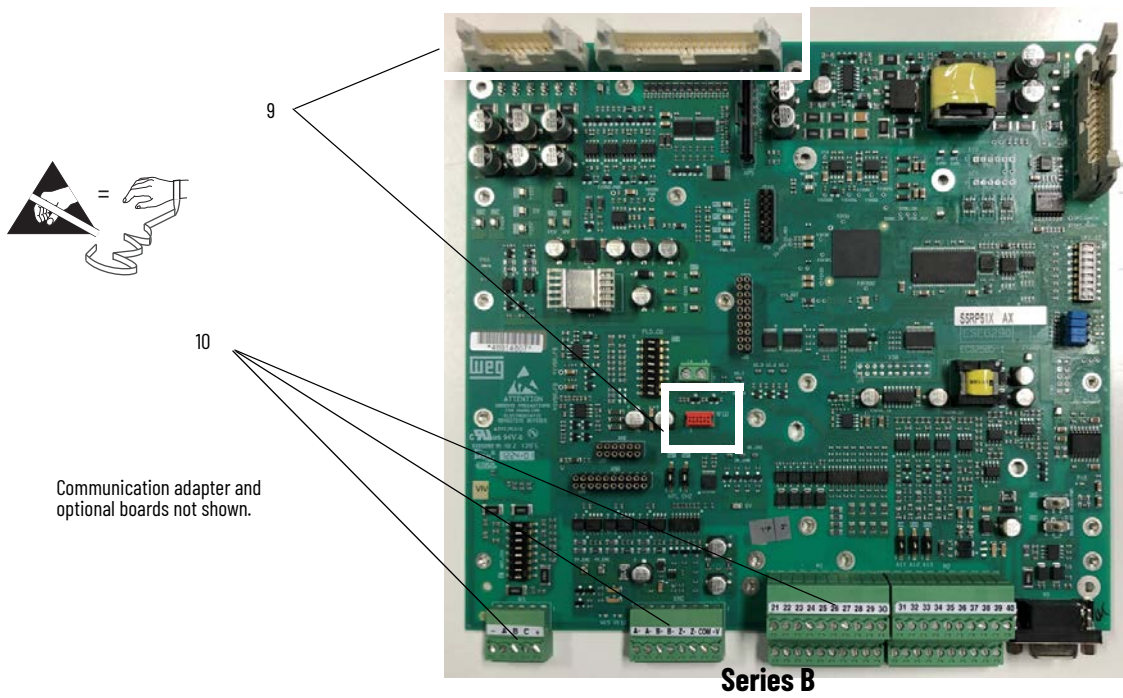
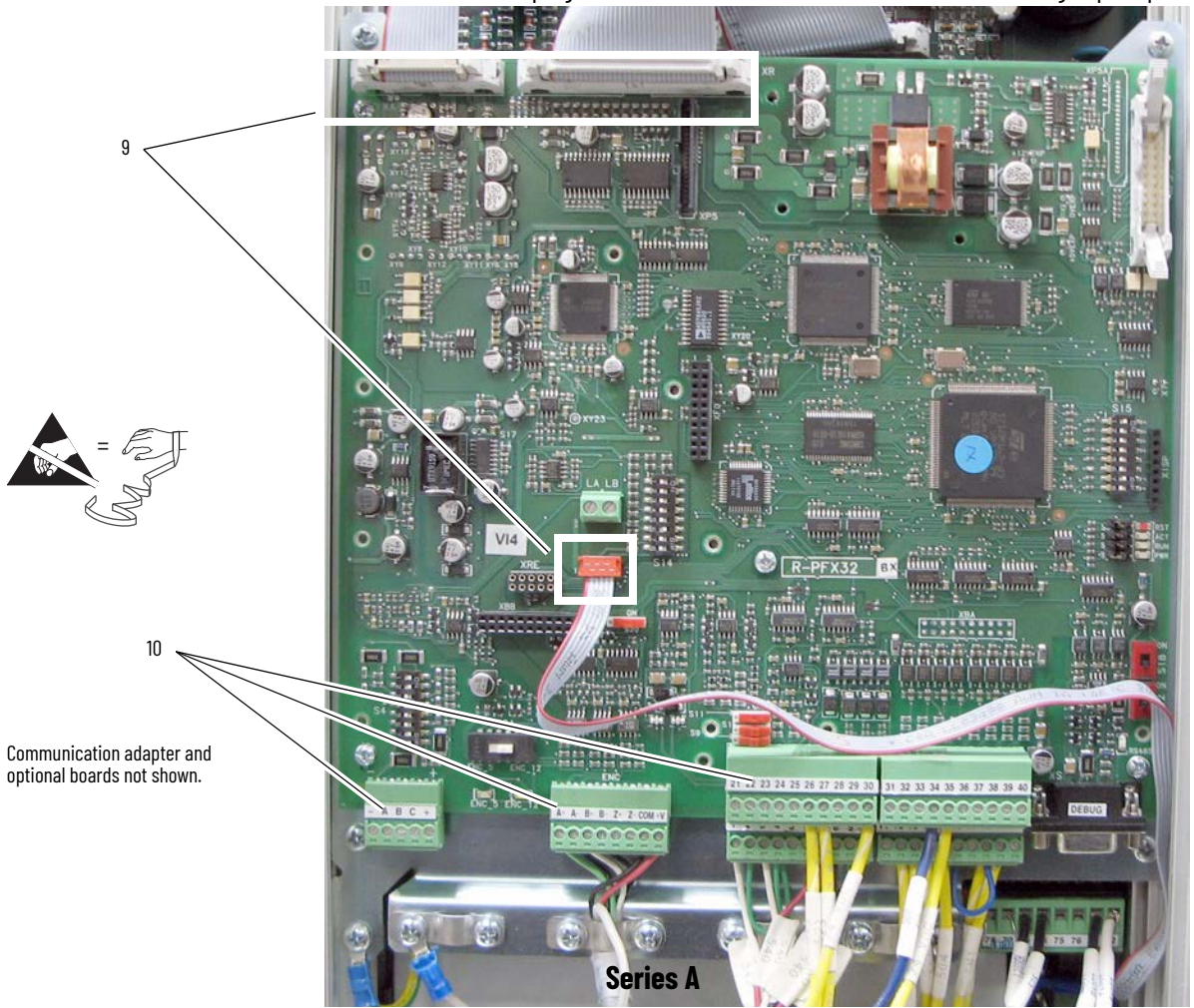

- 11. Remove the five M3 x 6 mm screws and washers that secure the control board to the control EMI shield and remove the control board.

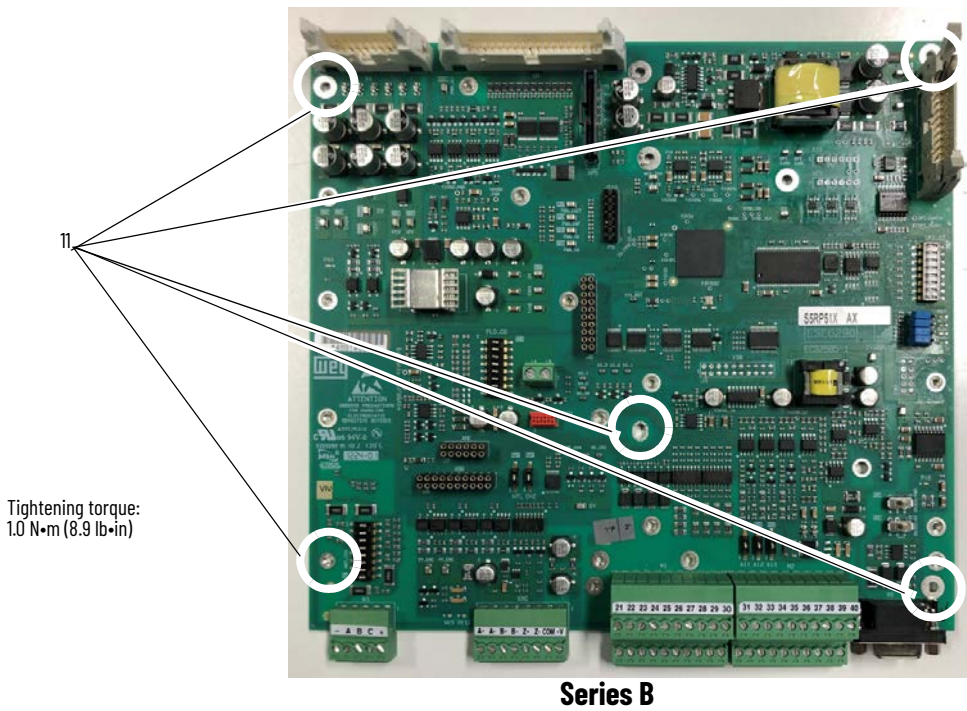
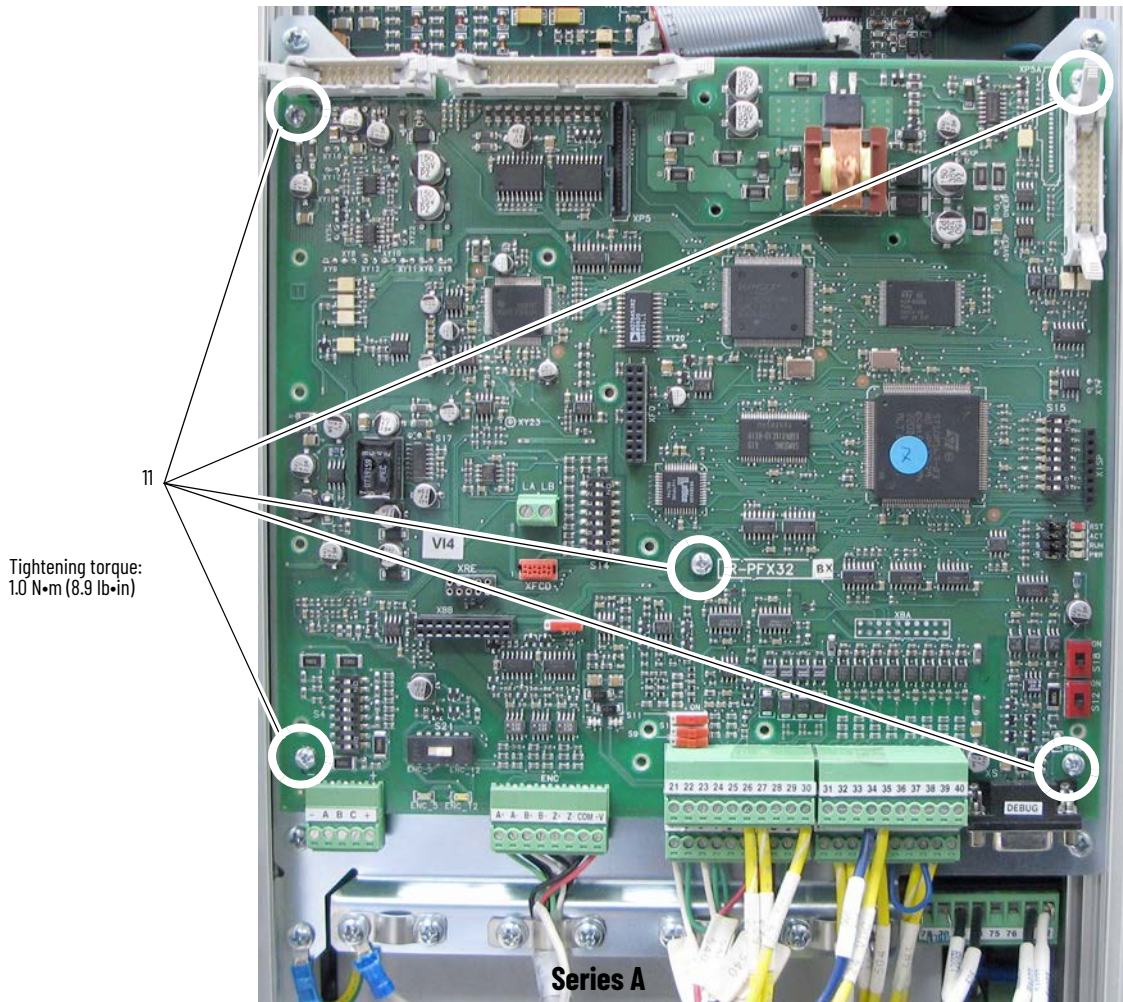

Install the Control Circuit Board

Install the control board in reverse order of removal.

- Verify that all DIP switches are set to the correct configuration based on your recorded settings (see page 60).

Control EMI Shield and Control Circuit Board Replacement

Remove the Control EMI Shield and Control Circuit Board

You must remove the control EMI shield that holds the control board to access other components within the drive. Follow these steps to remove the control EMI shield and control circuit board.

1. Read the General Safety Precautions on page 9.
2. Remove power from the drive (see page 43).
3. Remove the protective covers (see page 47).
4. Carefully disconnect the cables from connectors XFCD, XA, and XR on the control board.
5. Remove the plug-in I/O, analog tachometer, and encoder terminal blocks with the wiring kept in place (if used).

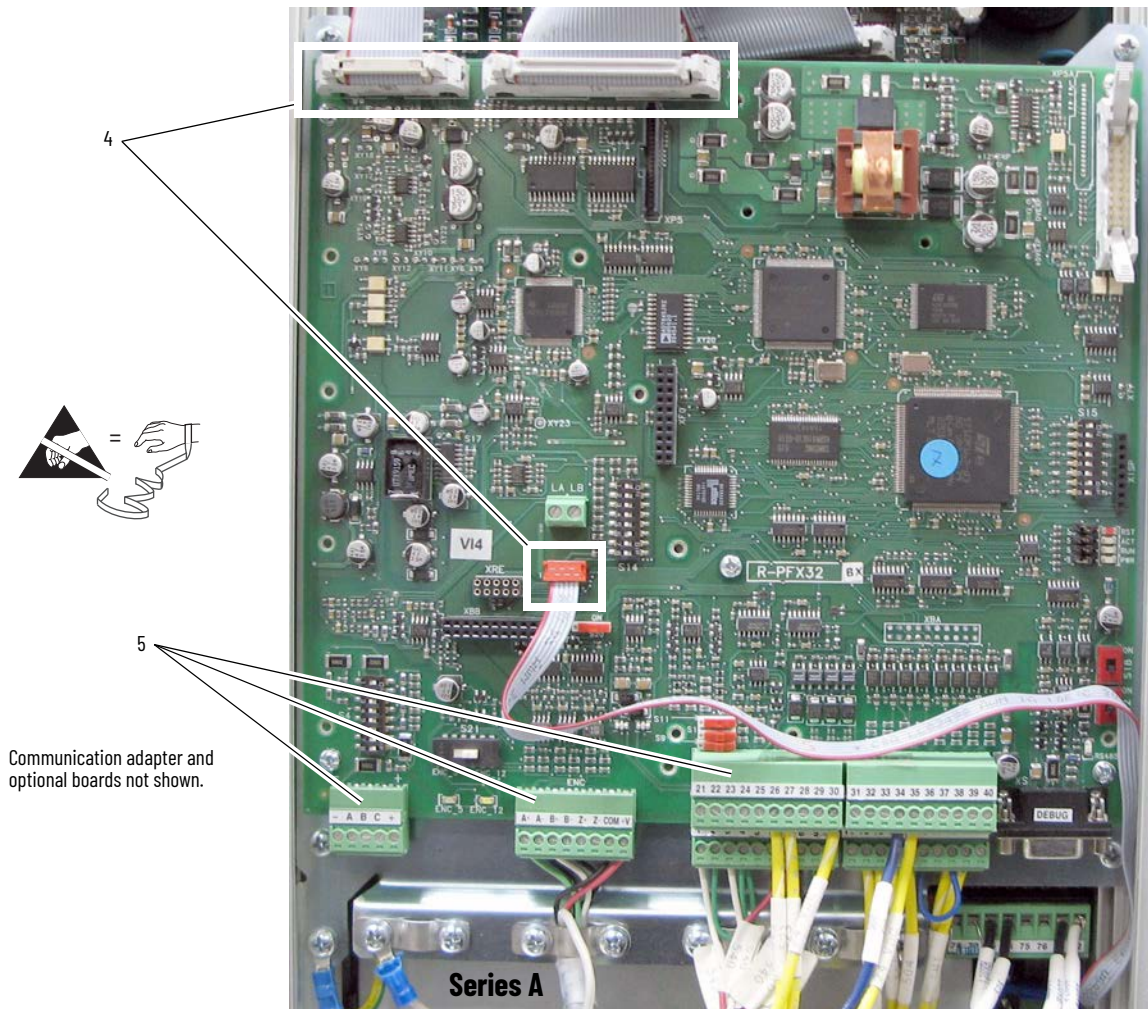

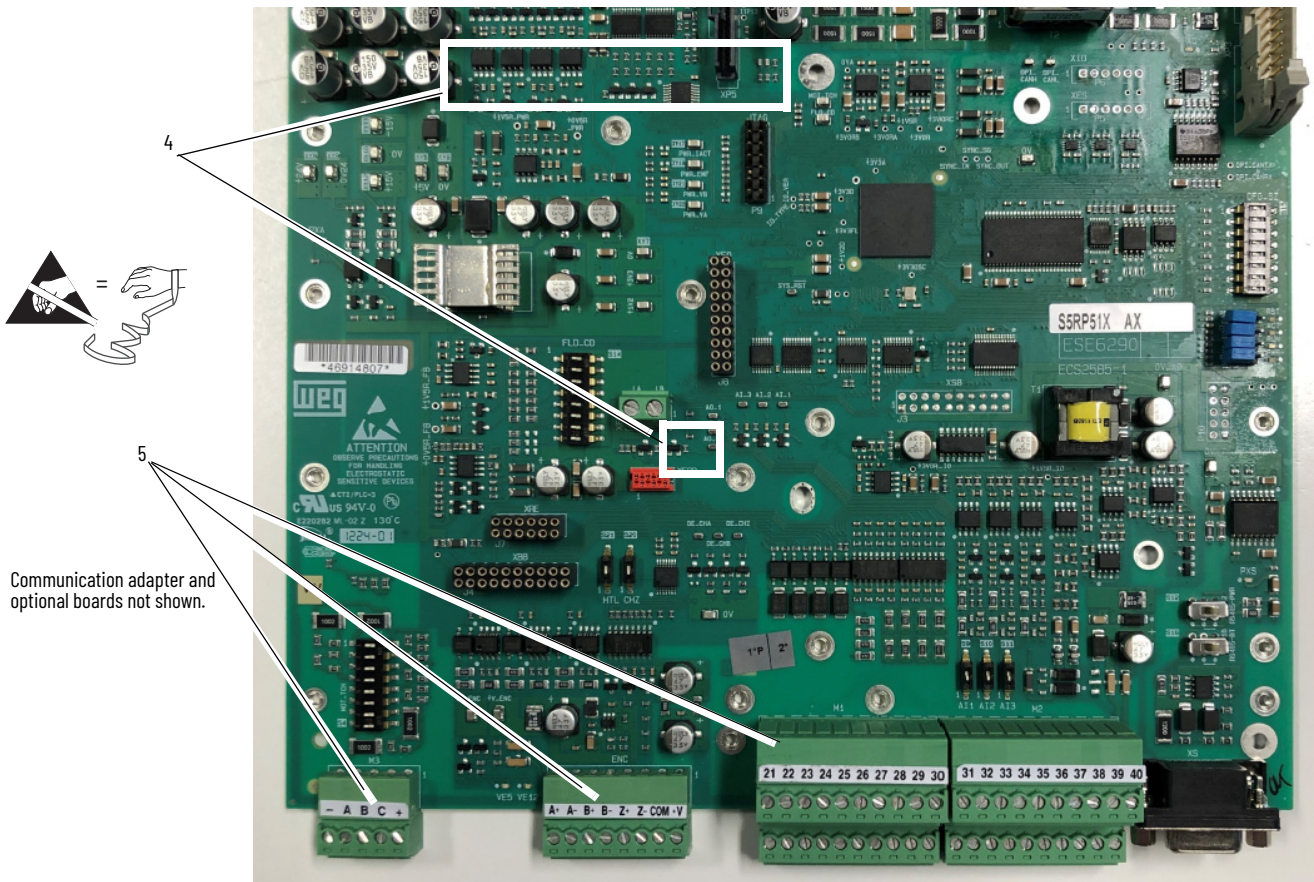

Series B

- 6. Remove the five M4 x 9.5 mm screws that secure the control EMI shield and ground wire (in the lower left corner) to the chassis.
- 7. Slide the control EMI shield and control board up and out of the drive.

IMPORTANT Be careful when removing the EMI shield not to pull free any of the gate leads or other cables on the pulse transformer circuit board below the EMI shield.

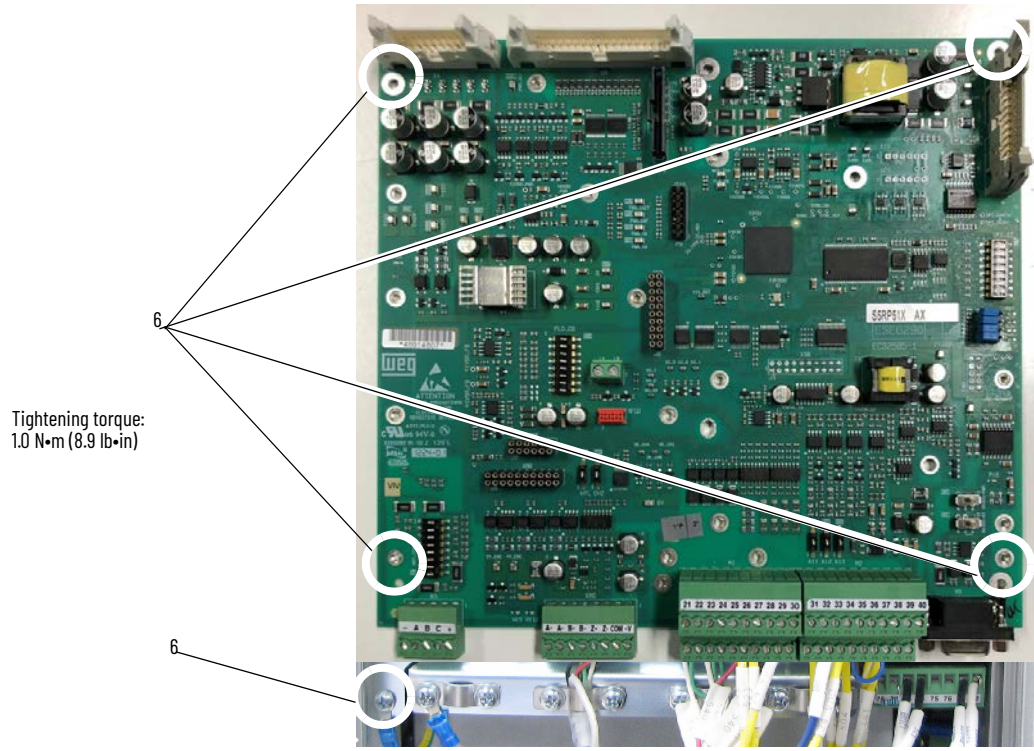
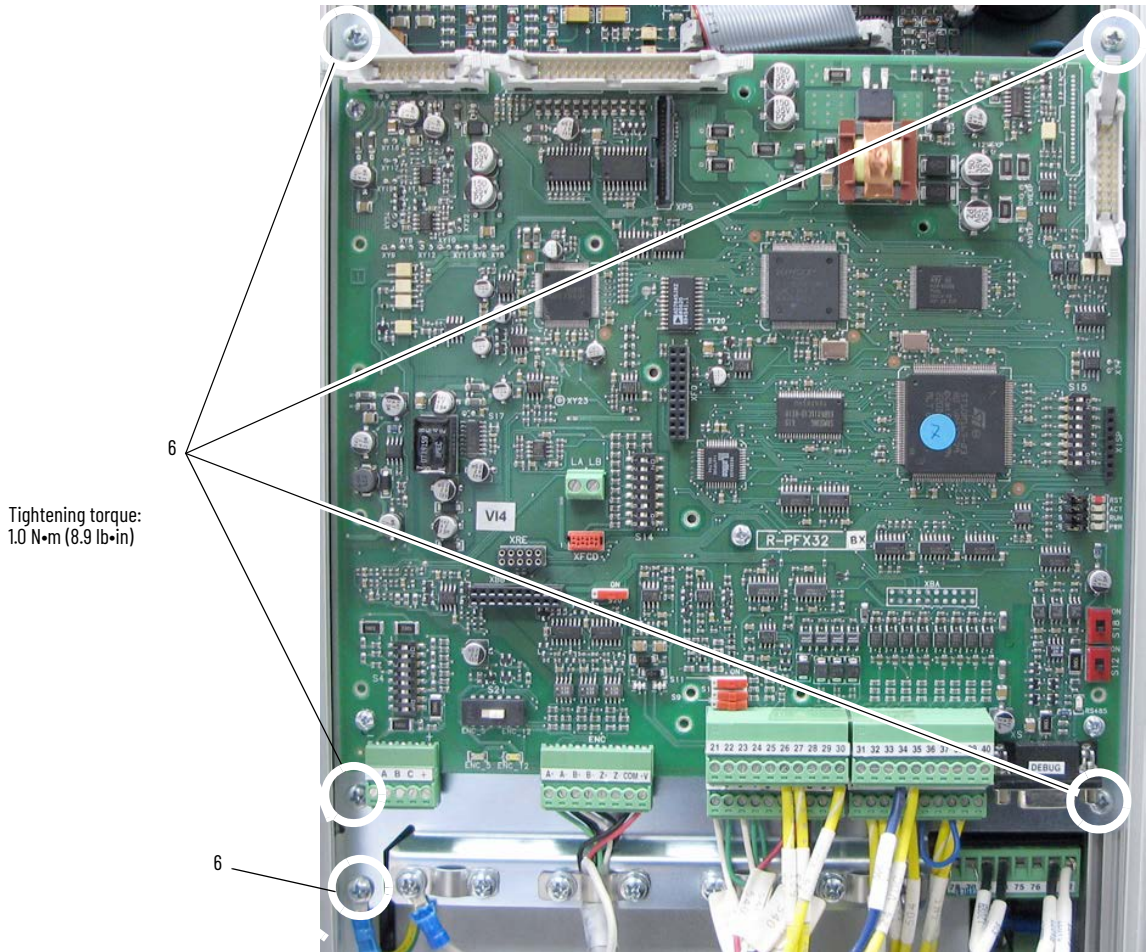

Install the Control EMI Shield and Control Circuit Board

Install the control EMI shield and control board in reverse order of removal.

Pulse Transformer and Switching Power Supply Circuit Boards Replacement

Remove the Pulse Transformer and Switching Power Supply Circuit Boards

The switching power supply circuit board is on the back of the pulse transformer circuit board. You must remove both boards to replace either board. Follow these steps to remove the pulse transformer and switching power supply circuit boards.

1. Read the General Safety Precautions on page [9](#).
2. Remove power from the drive (see page [43](#)).
3. Remove the protective covers (see page [47](#)).
4. Remove the control EMI shield and control board (see page [64](#)).
5. Remove the slotted air flow plate from the top of the drive.
 - For 38 A/10 Hp and 55 A/15 Hp drives with 230V AC input and 35 A/20 Hp, 45 A/25 Hp, and 52 A/30 Hp drives with 460V AC input, remove the four screws that secure the slotted air flow plate to the top of the drive.
 - Remove the fan cable from connector XV on the switching power supply board and remove the plate.

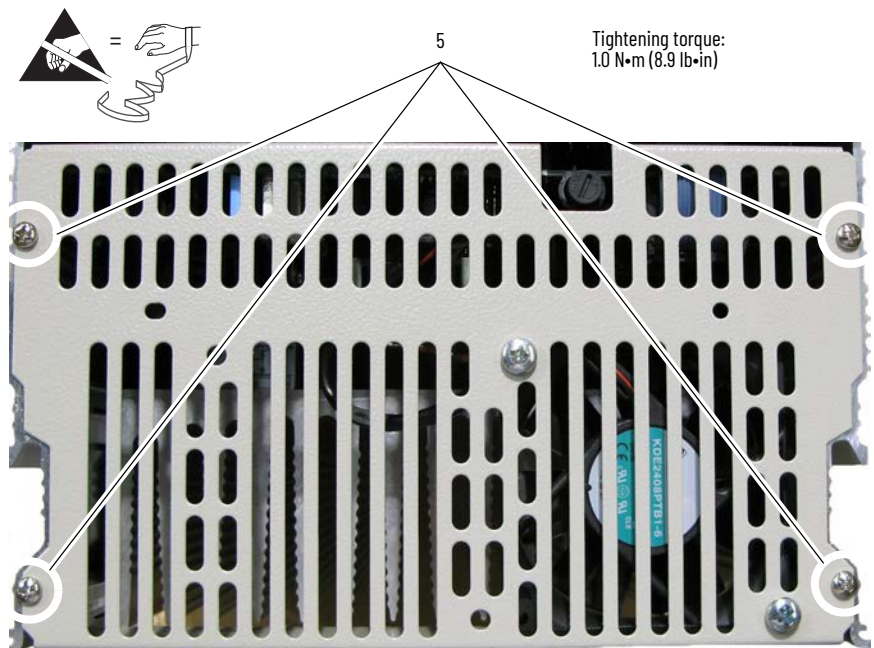

- For all other drives, remove the two screws that secure the slotted air flow plate to the top of the drive and remove the plate.



Tightening torque:
1.0 N•m (8.9 lb•in)

5

Air flow plate

5

Tightening torque:
1.0 N•m (8.9 lb•in)

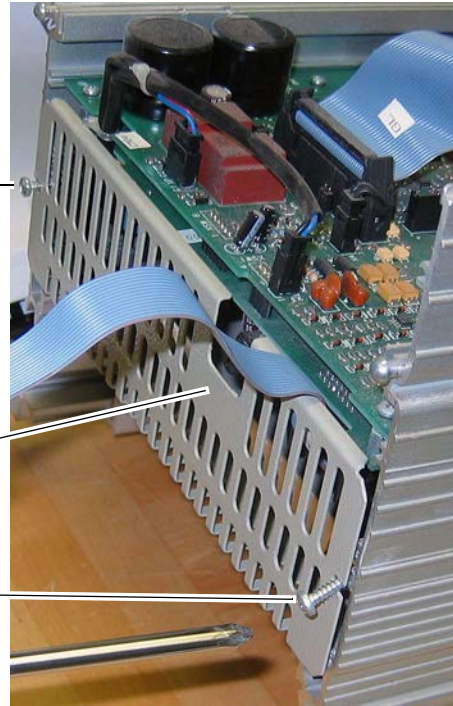

IMPORTANT Mark all connections and wires before removal to avoid incorrect wiring during reassembly.

6. Remove the plug-in control power terminal block from the lower right corner of the pulse transformer circuit board.

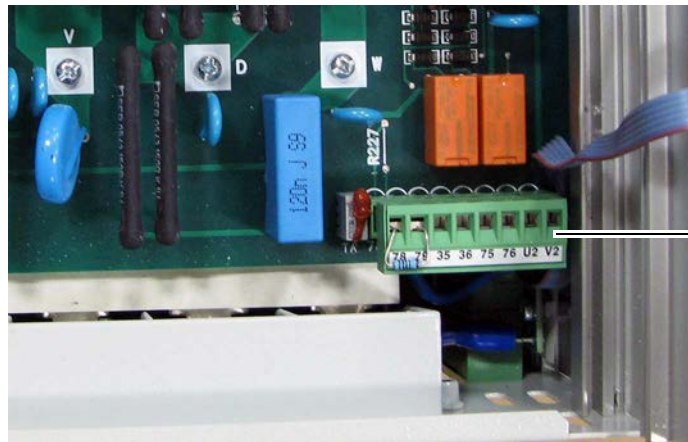

6

- Remove the cables from connectors X3, X4, and XP at the top of the pulse transformer board.

Connector X4 contains a jumper for drives without a fan - leave in place.

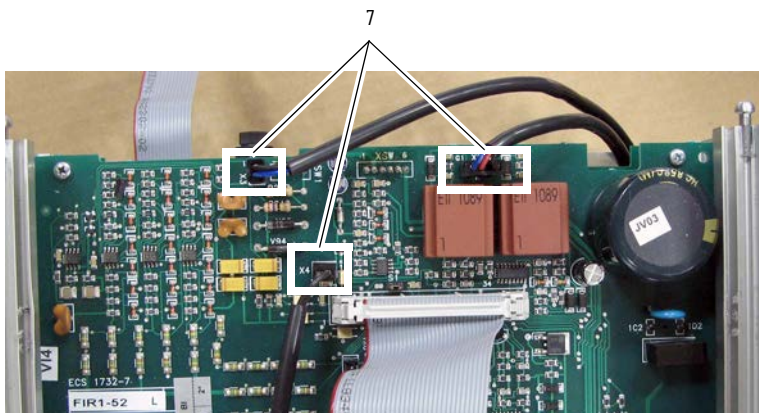

- For pulse transformer boards with an armature voltage feedback terminal block, FIR1-xx, rev "Q" and higher, remove the connector from XCD_10 on the upper left corner of the board.

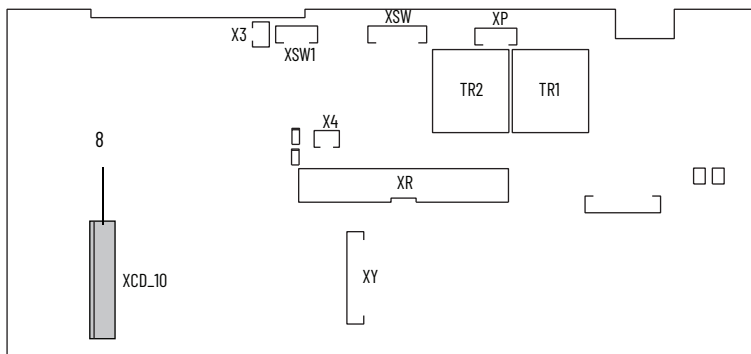

- Remove the plastic screw near the top of the pulse transformer board and retain for reuse.

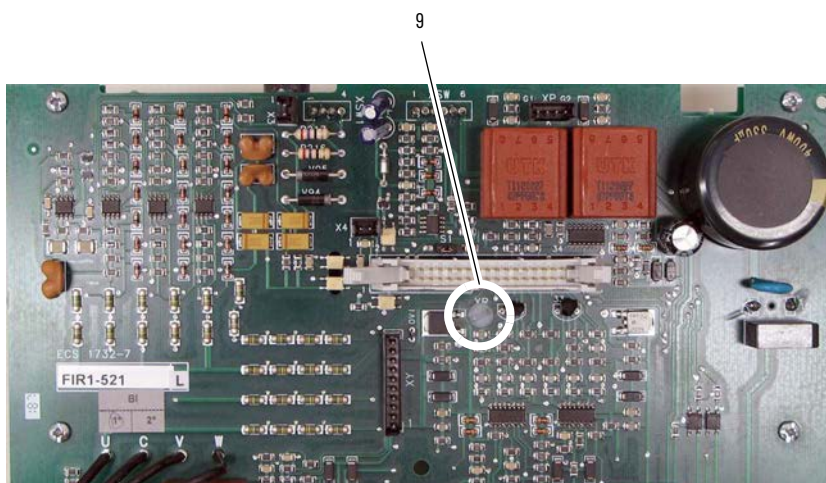

10. Remove the appropriate gate leads:
 - For regenerative drives, remove each pair of (orange and yellow) gate lead cables from connectors KG01...KG06 and KG1...KG6 and push each lead through the appropriate opening in the board.
 - For non-regenerative drives, remove each pair of (orange and yellow) gate lead cables from connectors KG01...KG06 and push each lead through the appropriate opening in the board.

IMPORTANT Carefully remove the gate leads by grasping the connector. DO NOT pull the gate leads off by pulling on the wires.

11. Remove the cable from connectors XTA on the lower right side of the board.

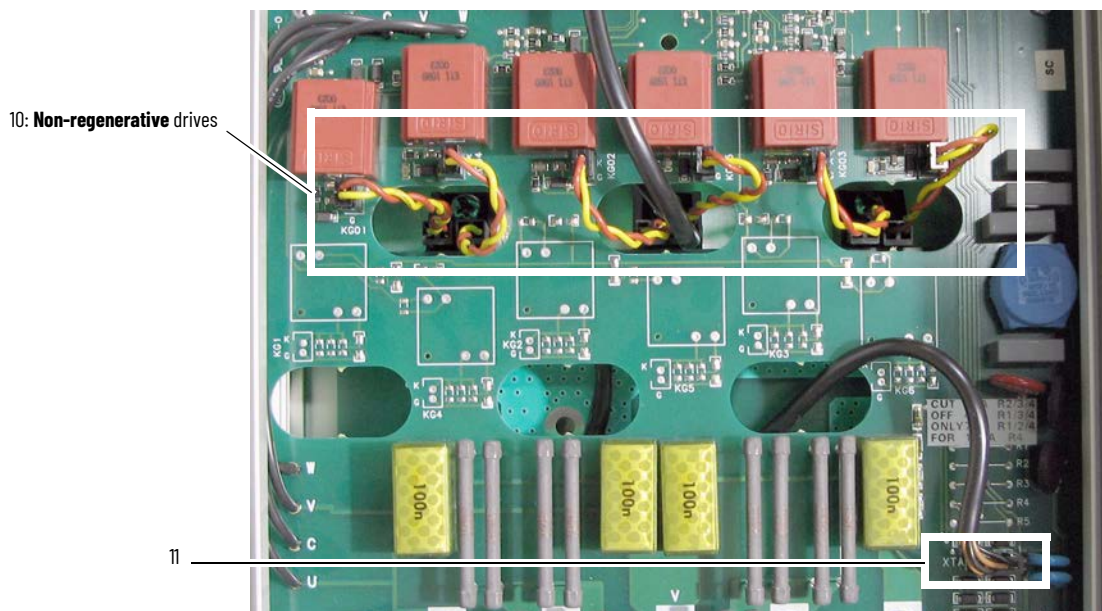
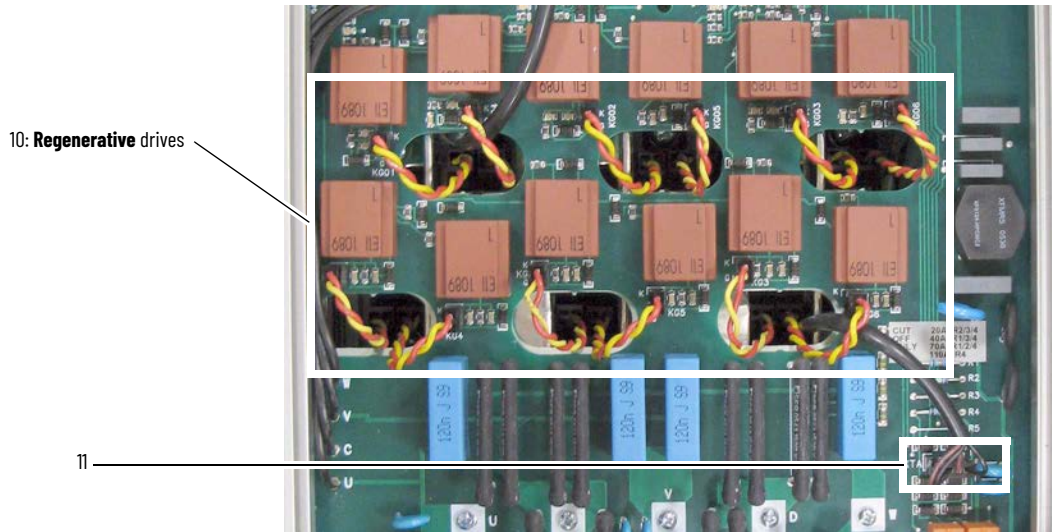

- 12. Remove the six M3 x 6 mm screws and washers that secure the bottom of the pulse transformer board to the drive.
- 13. While lifting slightly on the board, slide it toward the top of the drive and out of the chassis. There is an isolation sheet below the board; do not remove this sheet unless it is damaged.

IMPORTANT The cables from connectors X4 and XTA must slide through the openings in the board as it is lifted out of the drive chassis. Take care not to damage these cables and connectors.

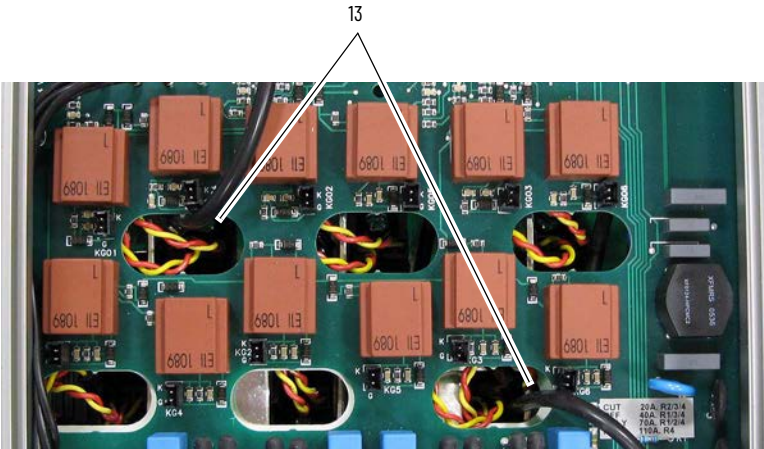
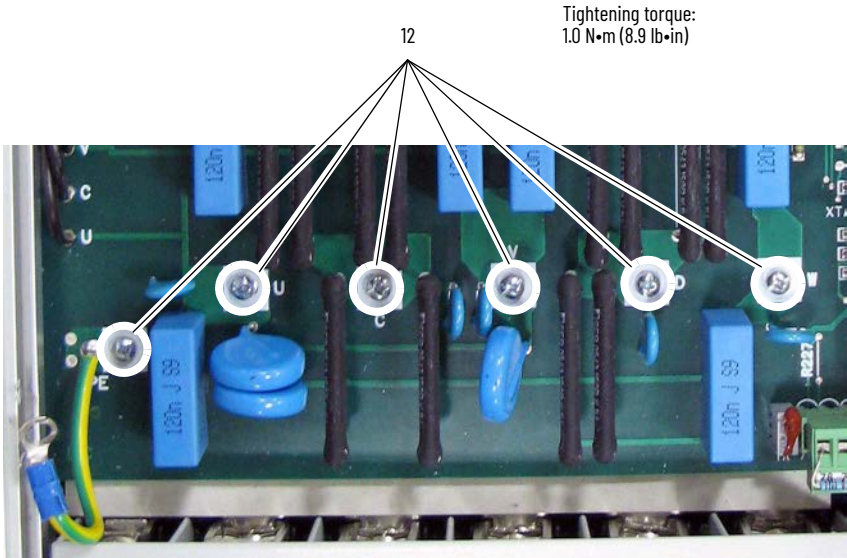

Regenerative drive shown

14. Remove the cable from connector XUV on the left side of the switching power supply board.
15. Remove the four M3 x 6 mm screws and washers that secure the switching power supply board to the stand-offs on the back of the pulse transformer board. Remove the switching power supply board.

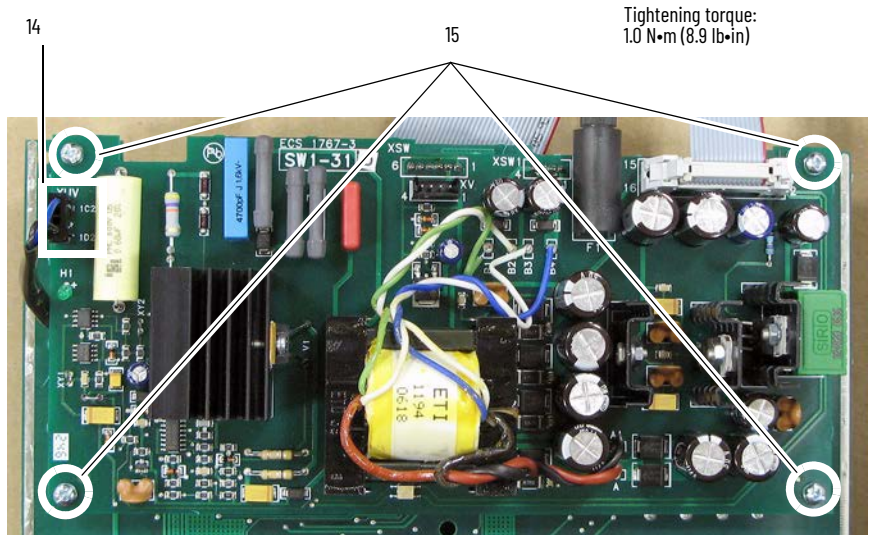

16. Remove the plastic stand-off and nut that secures the switching power supply board to the back of the pulse transformer board.

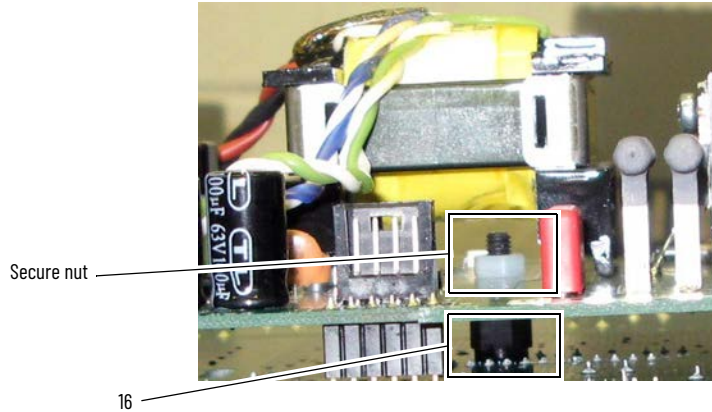

Install the Pulse Transformer and Switching Power Supply Circuit Boards

The pulse transformer circuit board must be configured to match the drive size (armature output current and Hp rating). The steps that are required to complete the configuration are different based on the revision code of the board. See either, Configuring the Pulse Transformer Board FIR1-xx Rev. "P" and Lower, or Configure a Pulse Transformer Board FIR1-xx Rev. "Q" and Higher on page [77](#).

Configuring the Pulse Transformer Board FIR1-xx Rev. "P" and Lower

IMPORTANT This procedure requires a multimeter that measures resistance to thousandths of an ohm.

1. Based on the drive size, cut and remove one or more appropriate sizing resistors (if necessary) from the pulse transformer board. See [Table 13](#) or [Table 14](#) in the Sizing Resistor Configuration section on page [74](#) for the appropriate configuration.

Sizing resistors are on the lower right corner of the pulse transformer circuit board.

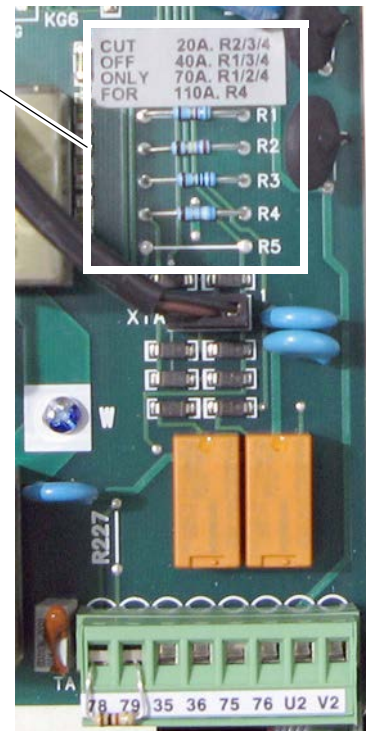

Sizing Resistor Configuration

Use [Table 13](#) and [Table 14](#) to determine the correct resistor configuration on the pulse transformer board for your drive size. The tables use these conventions:

- A resistance value in a cell indicates that the resistor must be left on the board
- "Remove" in a cell indicates that the resistor must be cut off the board
- "-" indicates that there is no resistor in that location on the board

Table 13 - 230V AC Input Drives

Drive Current Rating Code	DC Amps	AC Line Amps	Hp	R1	R2	R3	R4	R5
7P0	7	5.7	1.5	Remove	27.4 Ω	Remove	Remove	-
9P0	9	7.4	2	Remove	Remove	39.2 Ω	Remove	-
012	12	9.8	3	Remove	27.4 Ω	Remove	Remove	-
020	20	16	5	56.2 Ω	Remove	Remove	Remove	-
029	29	24	7.5	Remove	Remove	39.2 Ω	Remove	-
038	38	31	10	Remove	27.4 Ω	Remove	Remove	-
055	55	45	15	56.2 Ω	27.4 Ω	Remove	Remove	-
073	73	60	20	Remove	27.4 Ω	39.2 Ω	Remove	-
093	93	76	25	Remove	Remove	Remove	6.98 Ω	-
110	110	90	30	Remove	Remove	Remove	6.98 Ω	-

Table 14 - 460V AC Input Drives

Drive Current Rating Code	DC Amps	AC Line Amps	Hp	R1	R2	R3	R4	R5
4P1	4.1	3.3	2	56.2 Ω	Remove	Remove	Remove	-
6P0	6	4.9	3	Remove	Remove	39.2 Ω	Remove	-
010	10	8.2	5	Remove	Remove	39.2 Ω	Remove	-
014	14	11.4	7.5	Remove	27.4 Ω	Remove	Remove	-
019	19	15.5	10	56.2 Ω	Remove	Remove	Remove	-
027	27	22.1	15	Remove	Remove	39.2 Ω	Remove	-
035	35	28.6	20	Remove	27.4 Ω	Remove	Remove	-
045	45	36.8	25	56.2 Ω	Remove	39.2 Ω	Remove	-
052	52	42.5	30	56.2 Ω	27.4 Ω	Remove	Remove	-
073	73	59.6	40	Remove	27.4 Ω	39.2 Ω	Remove	-
086	86	70.3	50	Remove	Remove	Remove	6.98 Ω	-
100	100	81.7	60	Remove	Remove	Remove	6.98 Ω	-
129	129	105.4	75	Remove	Remove	Remove	6.98 Ω	-

2. Connect the leads of the multimeter to pins 13 and 14 of connector XR on the pulse transformer board (polarity is not important) and, using the TA potentiometer on the lower right corner of the pulse transformer circuit board, set the total resistance (RTA) to the appropriate value as indicated in [Table 15](#) or [Table 16](#) in the Total Resistance Values section on page [76](#).

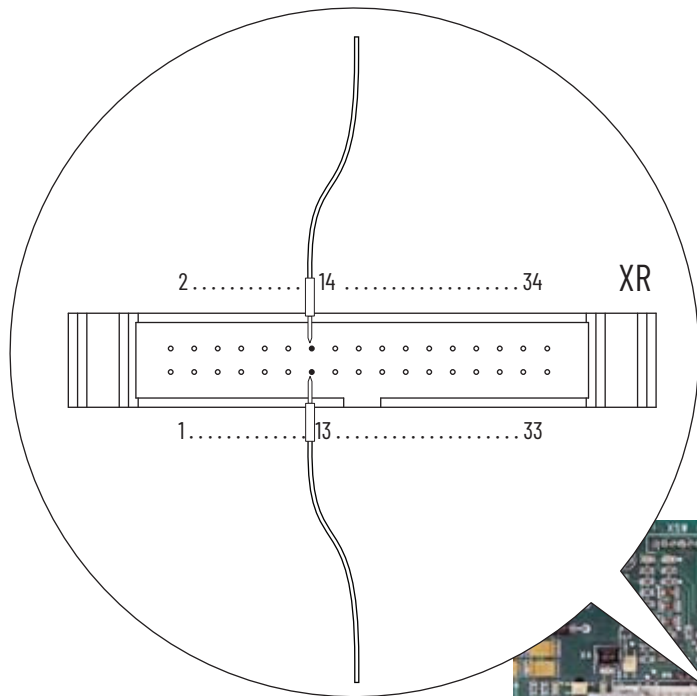

The XR connector is on the upper right corner of the pulse transformer circuit board.

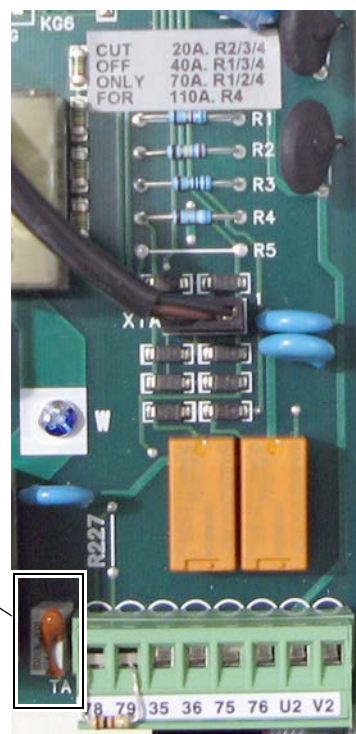
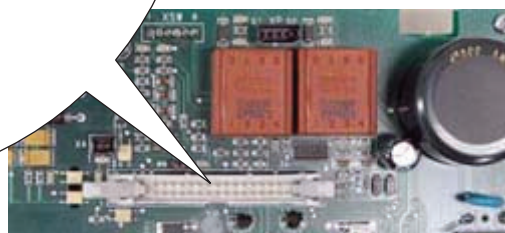

The TA potentiometer is on the lower right corner of the pulse transformer circuit board next to the control power terminal block. Shown sealed.

*Total Resistance Values***Table 15 - 230V AC Input Drives**

Drive Current Rating Code	DC Amps	AC Line Amps	Hp	Set RTA Value Using TA Potentiometer (Ohms)
7P0	7	5.7	1.5	34.971
9P0	9	7.4	2	45.333
012	12	9.8	3	34
020	20	16	5	61.2
029	29	24	7.5	42.207
038	38	31	10	32.211
055	55	45	15	22.255
073	73	60	20	16.767
093	93	76	25	13.161
110	110	90	30	11.127

Table 16 - 460V AC Input Drives

Drive Current Rating Code	DC Amps	AC Line Amps	Hp	Set RTA Value Using TA Potentiometer (Ohms)
4P1	4.1	3.3	2	59.707
6P0	6	4.9	3	40.8
010	10	8.2	5	40.8
014	14	11.4	7.5	29.143
019	19	15.5	10	64.421
027	27	22.1	15	45.333
035	35	28.6	20	34.971
045	45	36.8	25	27.2
052	52	42.5	30	23.538
073	73	59.6	40	16.767
086	86	70.3	50	14.233
100	100	81.7	60	12.24
129	129	105.4	75	9.488

3. Seal the TA potentiometer in place using RTV (silicon).
4. Continue with Install the Configured Pulse Transformer Circuit Board and the Switching Power Supply Circuit Boards on page [79](#).

Configure a Pulse Transformer Board FIR1-xx Rev. "Q" and Higher

- 1. Set DIP switches S3 and S4, on the pulse transformer board (see illustration), to the correct settings based on the drive current rating. See 230V AC Input Drives on page 78 and 460V AC Input Drives on page 78.

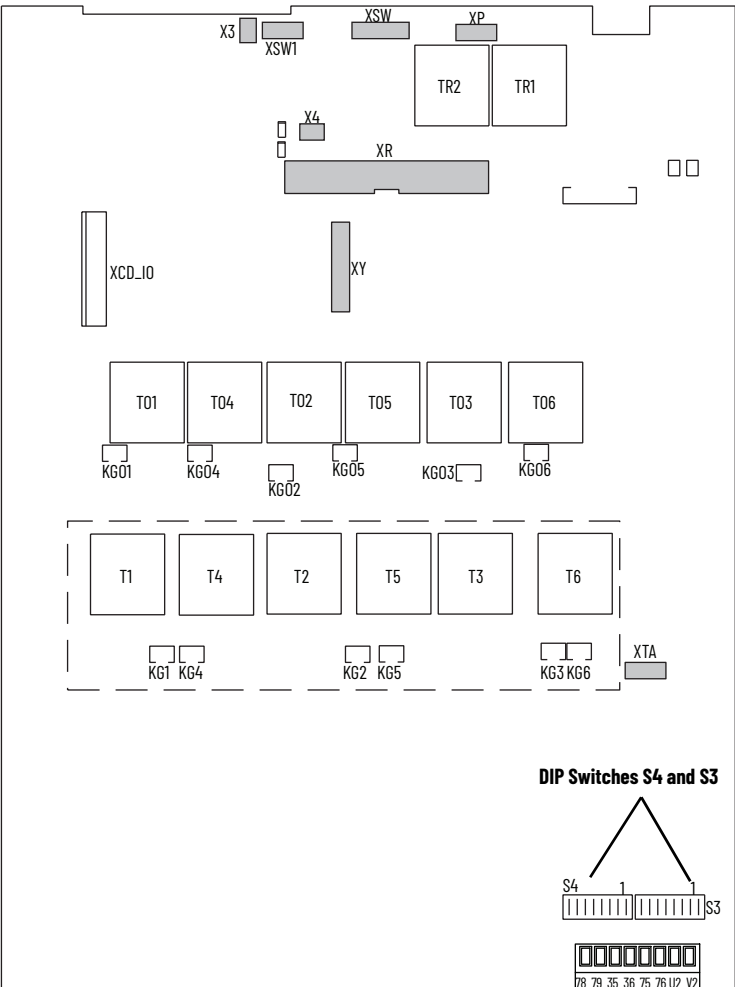

IMPORTANT A blank cell below a switch in [Table 17](#) and [Table 18](#) indicate that the setting is "OFF".

Table 17 - 230V AC Input Drives

Drive Current Rating Code	DC Amps	AC Line Amps	Hp	DIP Switch S3								DIP Switch S4							
				S3-1	S3-2	S3-3	S3-4	S3-5	S3-6	S3-7	S3-8	S4-1	S4-2	S4-3	S4-4	S4-5	S4-6	S4-7	S4-8
7P0	7	5.7	1.5					ON	ON		ON								
9P0	9	7.4	2		ON			ON	ON										
012	12	9.8	3		ON						ON	ON							
020	20	16	5	ON	ON		ON												
029	29	24	7.5		ON			ON		ON									
038	38	31	10		ON								ON						
055	55	45	15		ON	ON		ON					ON						
073	73	60	20							ON	ON	ON	ON						
093	93	76	25		ON			ON					ON		ON				
110	110	90	30				ON			ON				ON	ON				

Table 18 - 460V AC Input Drives

Drive Current Rating Code	DC Amps	AC Line Amps	Hp	DIP Switch S3								DIP Switch S4							
				S3-1	S3-2	S3-3	S3-4	S3-5	S3-6	S3-7	S3-8	S4-1	S4-2	S4-3	S4-4	S4-5	S4-6	S4-7	S4-8
4P1	4.1	3.3	2		ON	ON	ON												
6P0	6	4.9	3				ON	ON		ON									
010	10	8.2	5				ON	ON		ON									
014	14	11.4	7.5							ON	ON	ON							
019	19	15.5	10	ON	ON	ON													
027	27	22.1	15		ON			ON	ON										
035	35	28.6	20					ON	ON		ON								
045	45	36.8	25				ON	ON		ON	ON								
052	52	42.5	30					ON		ON	ON	ON							
073	73	59.6	40							ON	ON	ON	ON						
086	86	70.3	50					ON					ON		ON				
100	100	81.7	60					ON			ON		ON		ON				
129	129	105.4	75				ON					ON		ON	ON				

- Continue with Install the Configured Pulse Transformer Circuit Board and the Switching Power Supply Circuit Boards.

Install the Configured Pulse Transformer Circuit Board and the Switching Power Supply Circuit Boards

Follow these steps to the configured pulse transformer and switching power supply circuit boards.

1. Install the Isolation sheet (if present) before installing the pulse transformer and switching power supply boards.



ATTENTION: Failure to install the Isolation sheet below the pulse transformer and switching power supply boards can result in damage to the drive.

2. Install the configured pulse transformer board and switching power supply board in reverse order of removal.



ATTENTION: Each gate lead cable must be connected to the exact connector from which it was removed on the pulse transformer circuit board or damage to the drive can occur. See [Figure 21](#) on page [116](#) or [Figure 22](#) on page [116](#) for gate lead pinouts.

AC Current Transducer Replacement

Remove the AC Current Transducers

IMPORTANT AC current transducers must be replaced in pairs.

Follow these steps to remove the AC current transducers.

1. Read the General Safety Precautions on page [9](#).
2. Remove power from the drive (see page [43](#)).
3. Remove the protective covers (see page [47](#)).
4. Remove the control EMI shield and control circuit board (see page [64](#)).
5. Remove the pulse transformer and switching power supply circuit boards (see page [67](#)).

The drive rating determines the power bridge configuration and where the AC current transducers are in the drive:

- For these drive ratings the AC current transducers are installed on the power traces board.

- 230V AC input: 55 A / 15 Hp
- 460V AC input: up to 52A / 30 Hp

See AC Current Transducers on Drives with a Power Traces Board on page [80](#).

- For these drive ratings the AC current transducers are installed on bus bars inside the drive.

- 230V AC input: 73 A / 20 Hp and higher
- 460V AC input: 73 A / 40 Hp and higher

See AC Current Transducers on Drives with Bus Bars on page [82](#).

AC Current Transducers on Drives with a Power Traces Board

The drive size determines how the AC current transducers are secured to the power traces board. See Remove the Current Transducers with Connection Bars for drives with one metal bar and no windings on the AC current transducers. See Remove the Current Transducers with No Connection Bars on page 81 for drives no metal bar and windings on the AC current transducers.

Remove the Current Transducers with Connection Bars

6. Remove the four M3 x 6 mm screws and washers that secure the top of the AC current transducers to the power traces board.
7. Remove the two stand-offs that secure the bottom of the AC current transducers to the power traces circuit board and remove the AC current transducers from the drive.

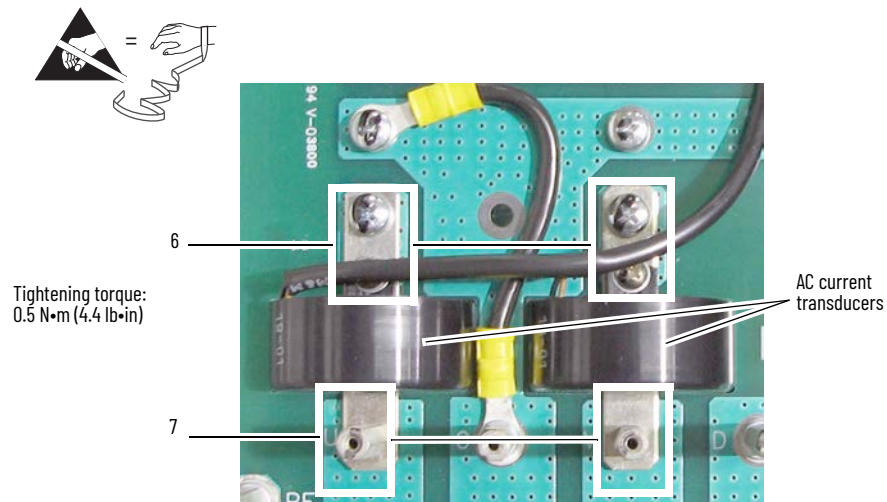

Non-regenerative drive shown

8. Continue with Install the AC Current Transducers on page 84.

Remove the Current Transducers with No Connection Bars

9. Remove the two M3 x 6 mm screws and washers that secure the top wire leads to the power traces board.
10. Remove the two stand-offs and washers that secure the bottom wire leads to the power traces board.

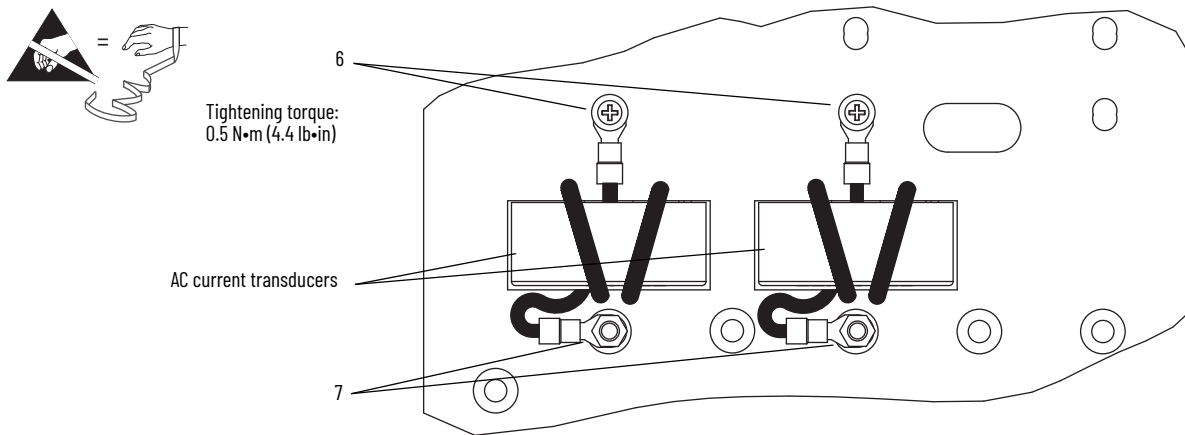

11. Turn the board over and remove the two M3 x 6 mm screws and washers that secure the AC current transducers to the board and remove the AC current transducers and windings (if present) from the drive.

IMPORTANT You do not need to remove the windings from the AC current transducers. However, note the position and number of wire lead windings for proper installation of the new AC current transducers.

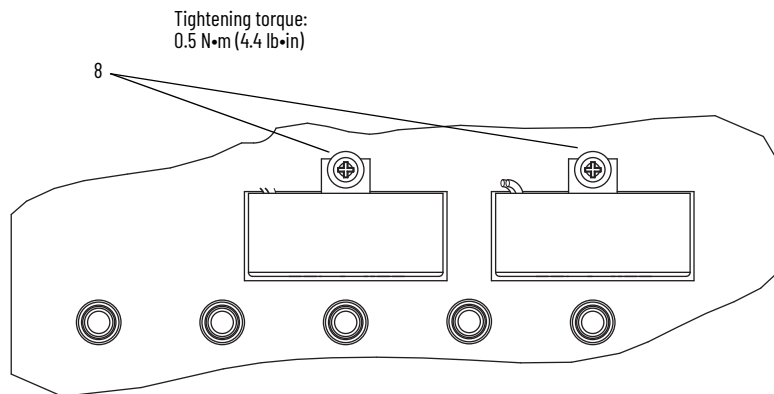

12. Continue with Install the AC Current Transducers on page [84](#).

AC Current Transducers on Drives with Bus Bars

IMPORTANT Mark all connections and wires before removal to avoid incorrect wiring during reassembly.

- 13. Remove the power connections from terminals U and V at the bottom of the drive.
- 14. Remove the M4 x12.5 mm screws and washers that secure each of the AC current transducers to the U and V Phase terminal bus bars.

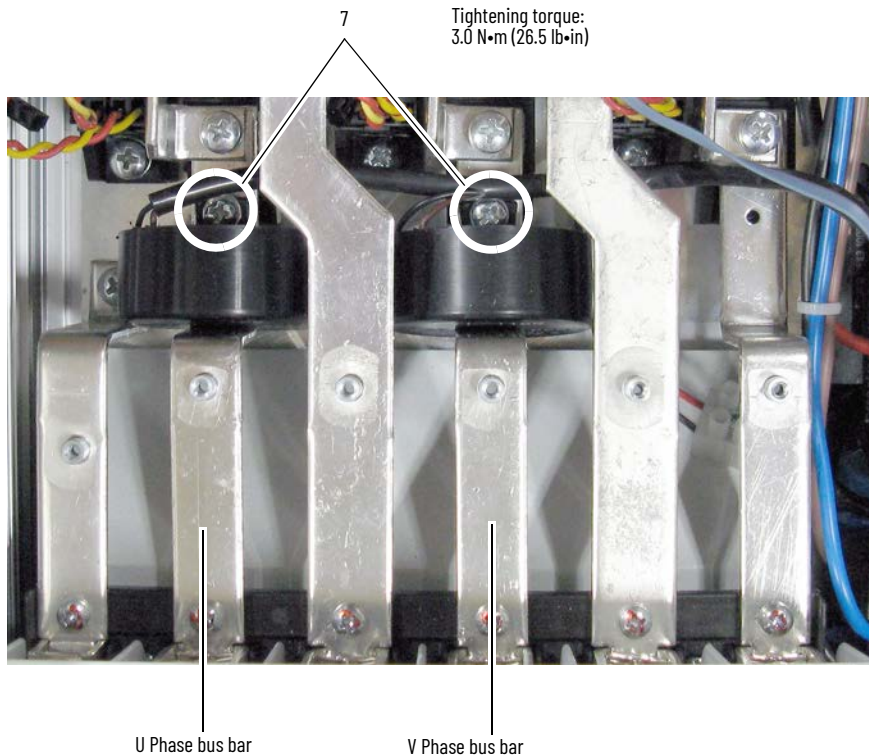

15. Remove the two 5 x 10 mm screws and washers that secure each of the U and V phase terminal bus bars to the terminal isolation strip at the bottom of the drive.

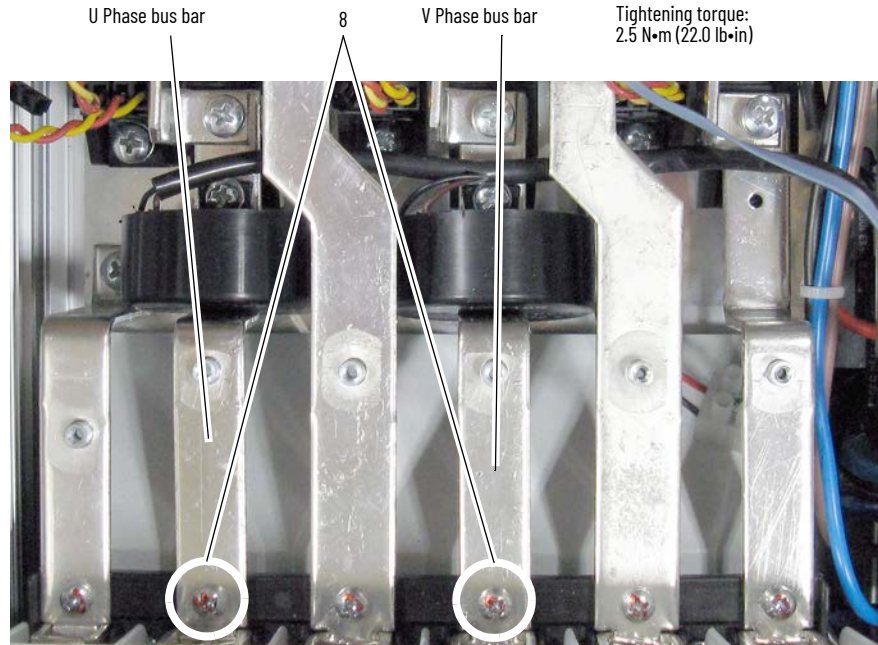

16. Remove the screws and washers that secure each of the U and V phase terminal bus bars, which contain the AC current transducers, to the SCR modules.
- For Regenerative drives, remove the top and bottom screws and washers that secure the connecting bus bars and U and V phase terminal bus bars to the SCR modules and remove the connecting bus bars.

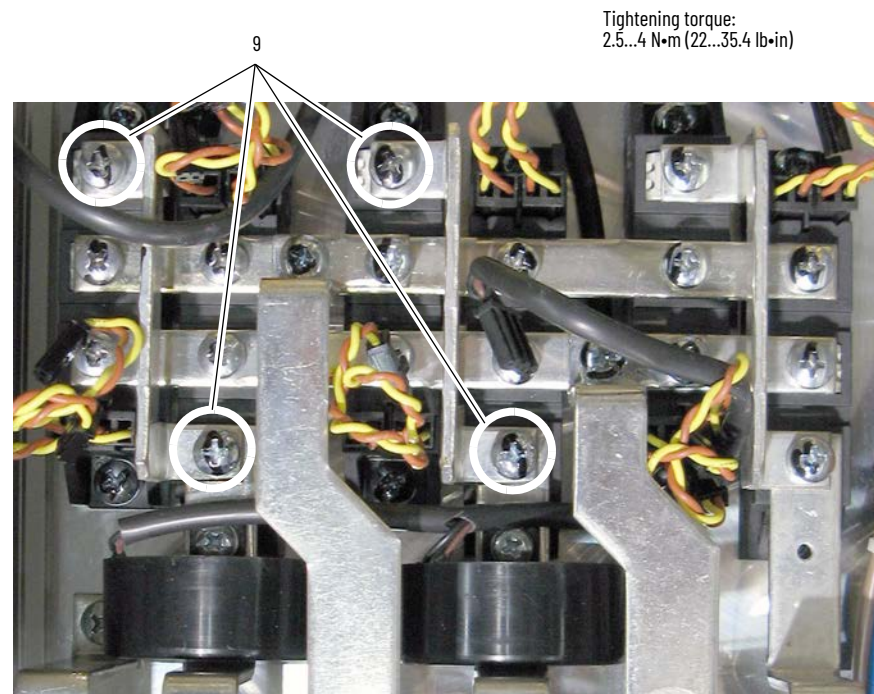

- For Non-Regenerative drives, remove the screws and washers that secure the U and V Phase terminal bus bars to the corresponding SCR modules.

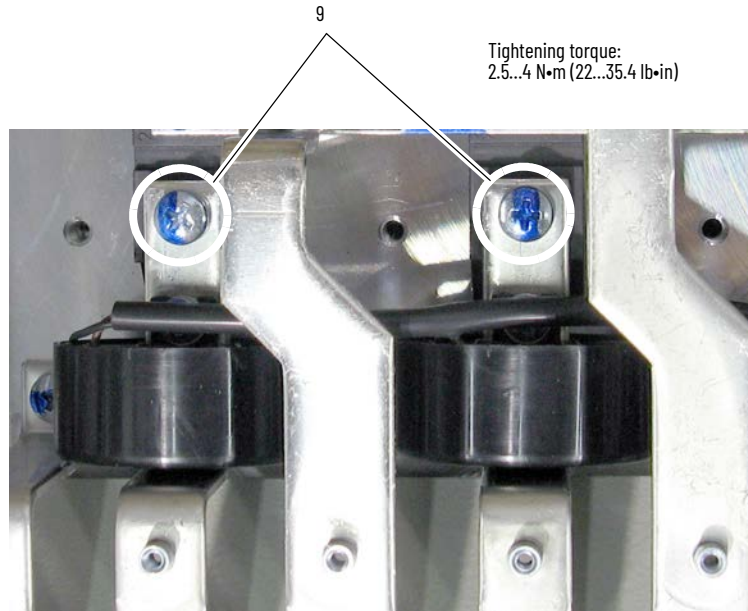

17. While lifting the terminal bus bars out of the drive, slide the AC current transducers off the bus bars.

Install the AC Current Transducers

Install the AC current transducers in reverse order of removal.

For AC current transducers that must be wound with wire leads:

- Wind the wire leads around the new AC current transducers:
 - Wind the wires the same number of times as the wires on the old AC current transducers
 - Wind the wires in the same position as the wires on the old AC current transducers
- Crimp the connection lugs onto the wire leads before they are secured to the power traces board.

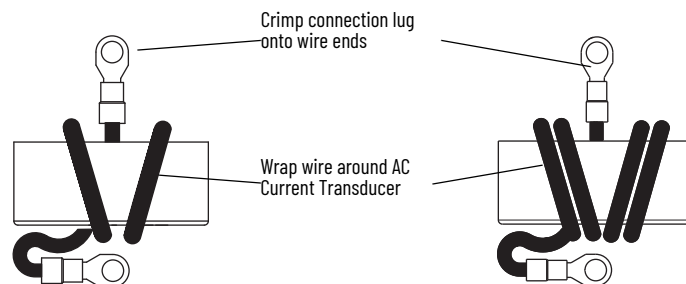

Power Traces Circuit Board Replacement

Remove the Power Traces Circuit Board

The power traces circuit board is only contained in frame A drives rated up to 55 A/15 Hp with 230V AC input and up to 52 A/30 Hp with 460V AC input. follow these steps to remove the power traces circuit board.

1. Read the General Safety Precautions on page [9](#).
2. Remove power from the drive (see page [43](#)).
3. Remove the protective covers (see page [47](#)).
4. Remove the M5 x 10 mm screws and washers that secure the terminal lugs (if present) and power and ground wiring to terminals U, V, W, C, D, and PE at the bottom of the drive.

Note: Non-regenerative drive without terminal lugs shown.

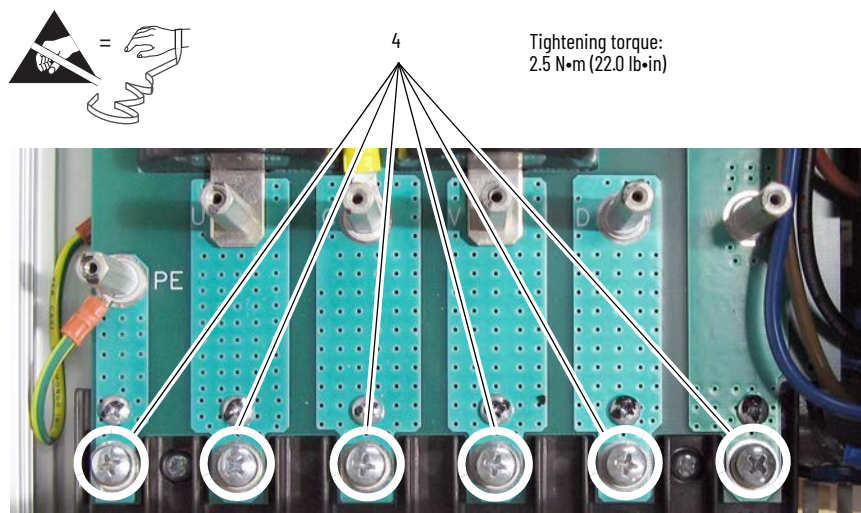

5. Remove the control EMI shield and control board (see page [64](#)).
6. Remove the pulse transformer and switching power supply circuit boards (see page [67](#)).
7. Remove the six stand-offs (and the ground wire) from the power traces circuit board.

8. Remove all M5 x 10 mm screws and washers that secure the board to the SCR modules and power terminal isolation strip and remove the power traces board from the drive.



Non-Regenerative drive with AC current transducers with connection bars

Tightening torque:
2.5 N·m (22.0 lb·in)

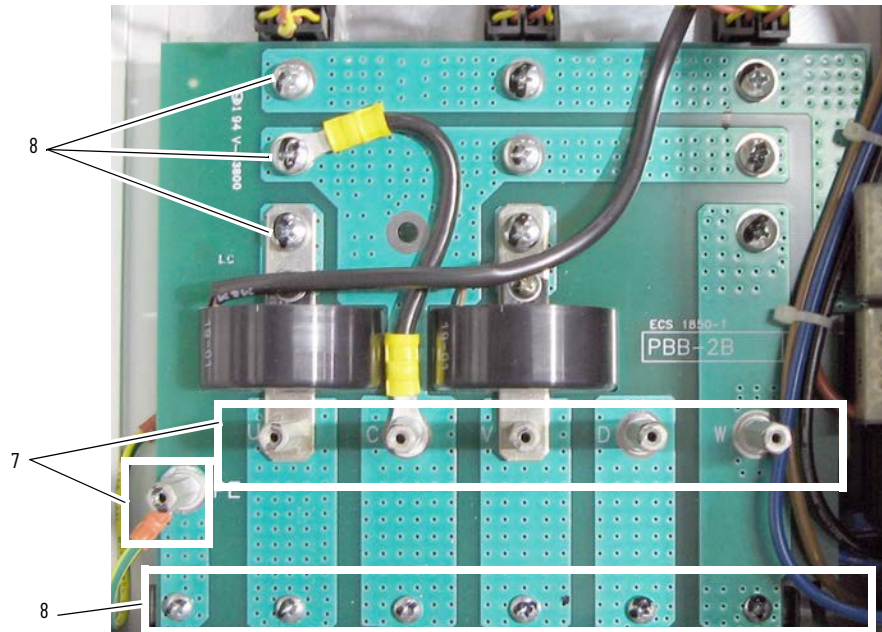

Regenerative drive with AC current transducers with connection bars

Tightening torque:
2.5 N·m (22.0 lb·in)

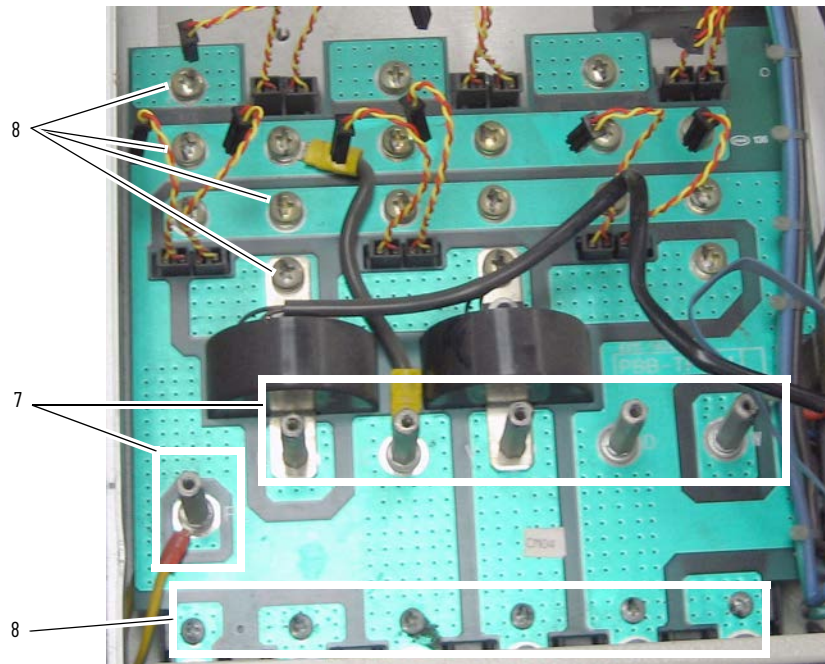

9. Remove the screw and washer that secures the top of each of the AC current transducers to the power traces board and remove the current transducers.

Regenerative drive shown

AC current transducers with connections bars

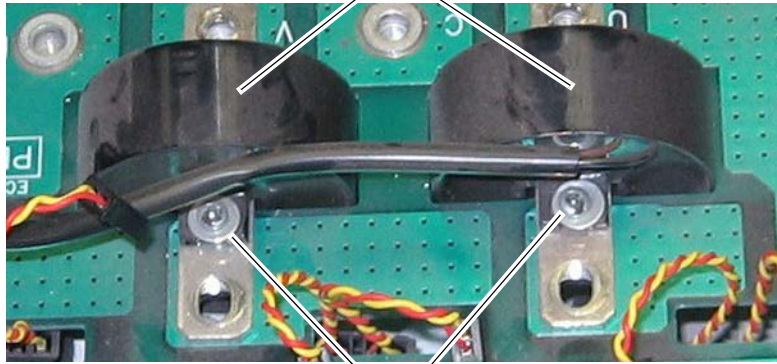

9

10. For drives with AC current transducers with no connection bars:
- Turn the board over and remove the two screws and washers that secure the AC current transducers to the board.
 - Remove the AC current transducers and windings (if present) from the drive.

IMPORTANT You do not need to remove the windings from the AC current transducers.

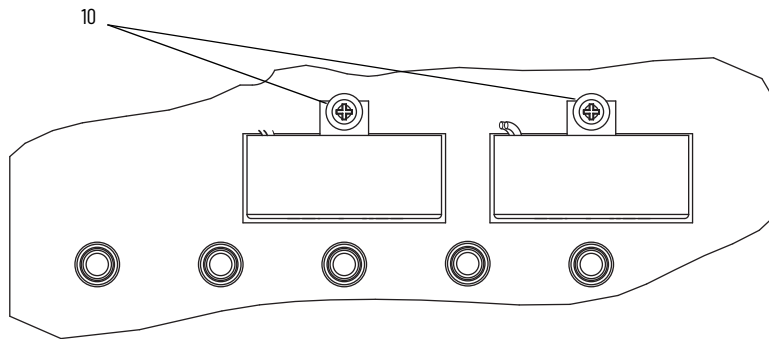

Install the Power Traces Circuit Board

Install the power traces circuit board in reverse order of removal.

- Verify the following actions are taken for proper installation:
 - The connecting wire on the board is placed in the exact location as previously installed.
 - The wires leads wound around the current transducers (if present) are in the same location as when previously installed.

Regenerative drive

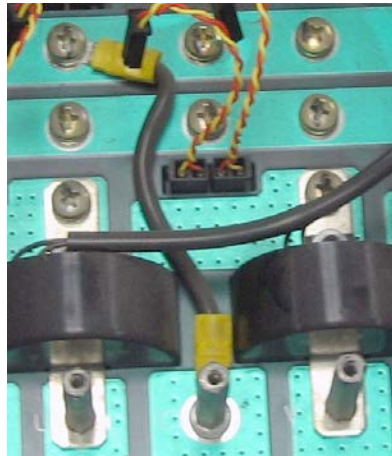

Non-regenerative drive

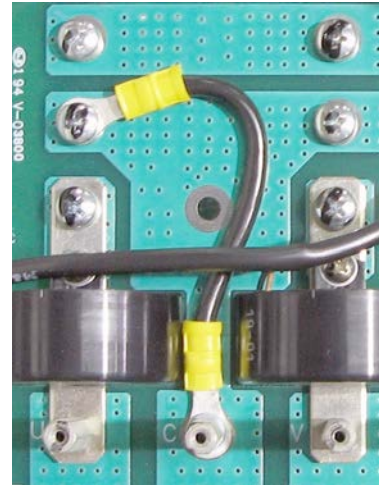

Field SCR/Dual Diode Module and Field Circuit Board Replacement

Remove the Field SCR/Dual Diode Module and Field Circuit Board

Follow these steps to remove the field SCR/dual diode module and field circuit board.

1. Read the General Safety Precautions on page [9](#).
2. Remove power from the drive (see page [43](#)).
3. Remove the protective covers (see page [47](#)).
4. Remove the control EMI shield and control circuit board (see page [64](#)).
5. Remove the pulse transformer and switching power supply circuit boards (see page [67](#)).

IMPORTANT Mark all connections and wires before removal to avoid incorrect wiring during reassembly.

6. Remove all wires from the field SCR/dual diode module on the drive heat sink. (You will also need to remove the small red wire that is staked to the large red wire.)
7. Remove the two M5 x 10 mm screws and washers that secure the field SCR/dual diode module to the drive heat sink and remove the module.



Tightening torque:
2.5 N·m (22.0 lb·in)

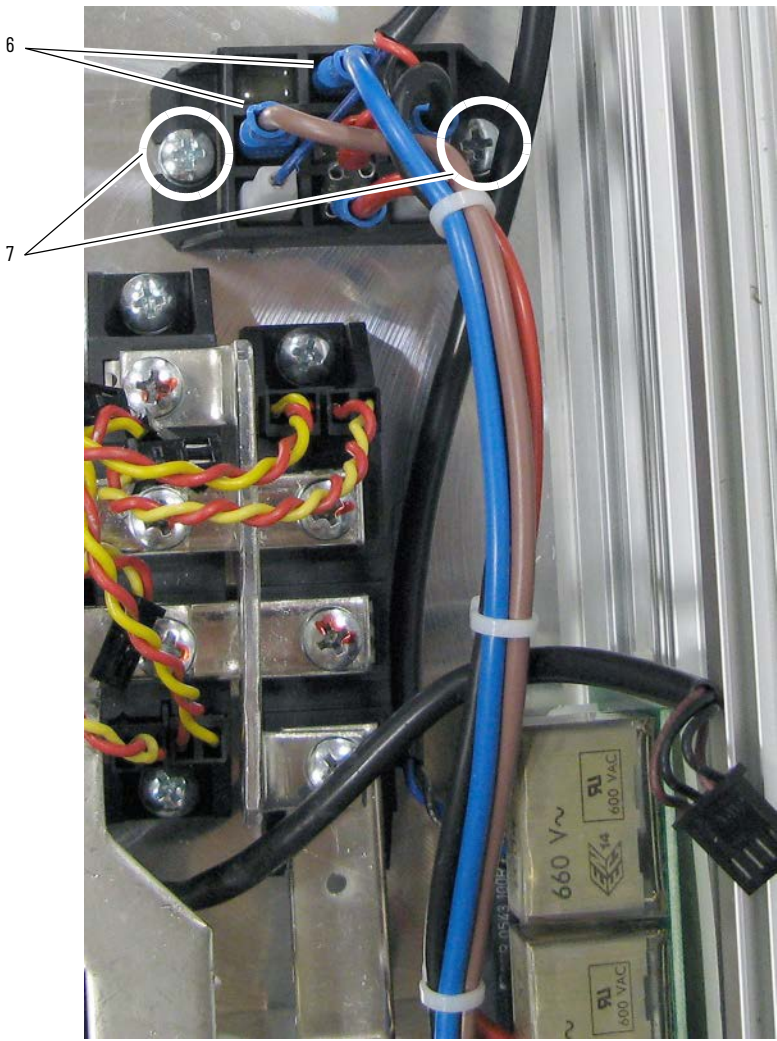

- 8. If necessary, remove the power wiring from terminals U, V, W, C, D, and PE.
- 9. Remove the plug-in field terminal block on the bottom of the drive, with the wiring kept in place.



- 10. Remove the two M4 x 12 mm screws that secure the bottom air flow plate to the power terminal isolation strip.

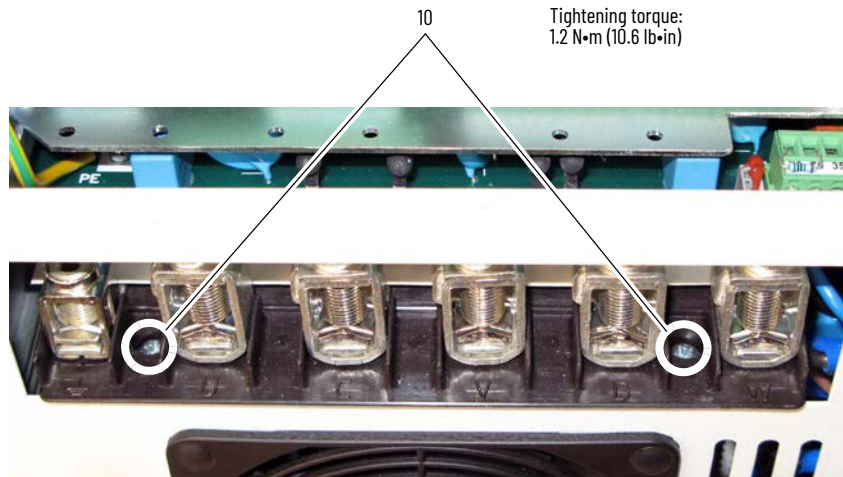

Drive with fan shown.

11. Remove the M4 x 12.5 mm screws that secure the bottom air flow plate to the drive chassis and carefully pull the air flow plate and fan (if present) assembly down and off the drive.

The bottom air flow plate on a frame A drive that is rated up to 55 A/15 Hp with 230V AC input or up to 52 A/30 Hp with 460V AC input, is secured to the drive chassis with four screws. The bottom air flow plate on a frame A drive with a fan are secured to the chassis with six screws.

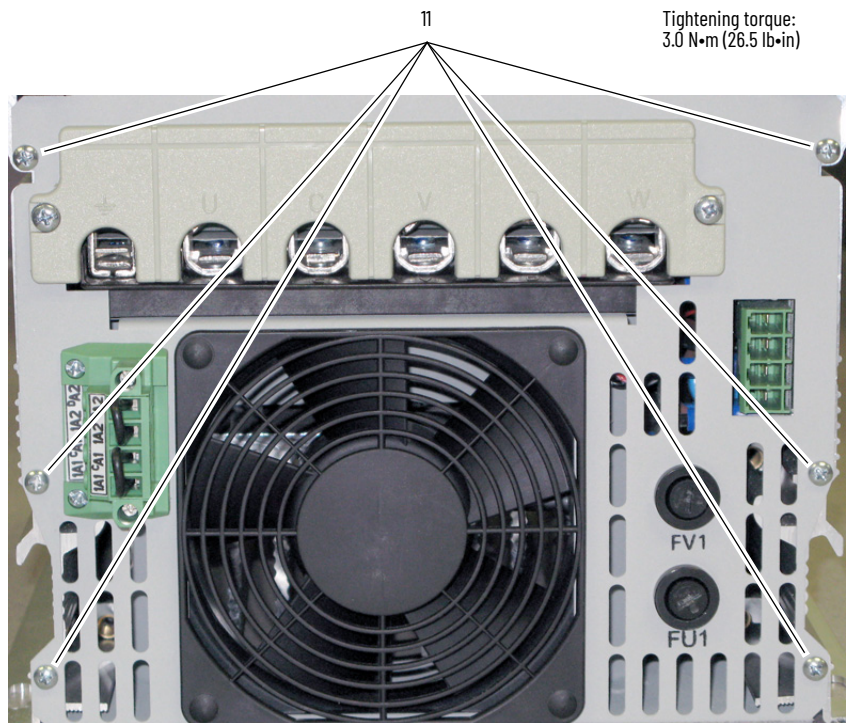
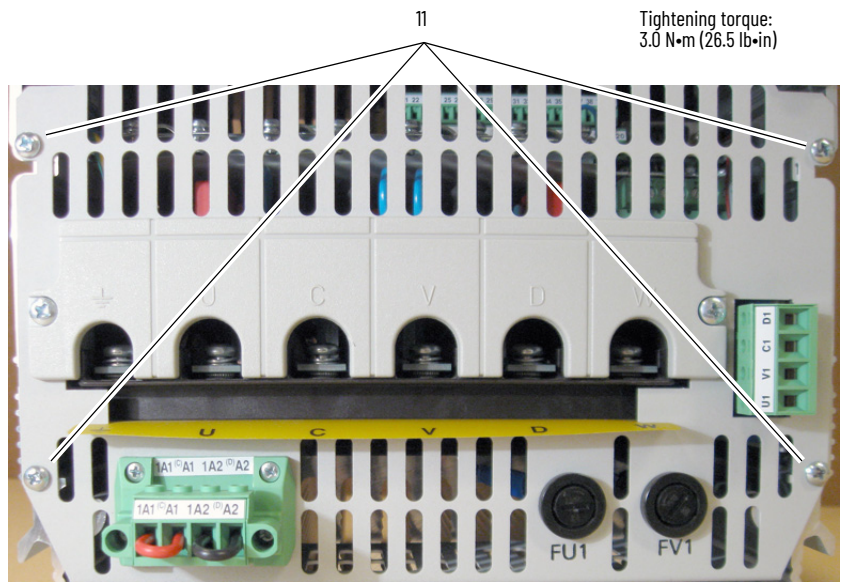

12. Remove the two M3 x 6 mm screws that secure the field circuit board to the drive and remove the field board and connected wires from the drive. There is an isolation sheet below the board; do not remove this sheet unless it is damaged.

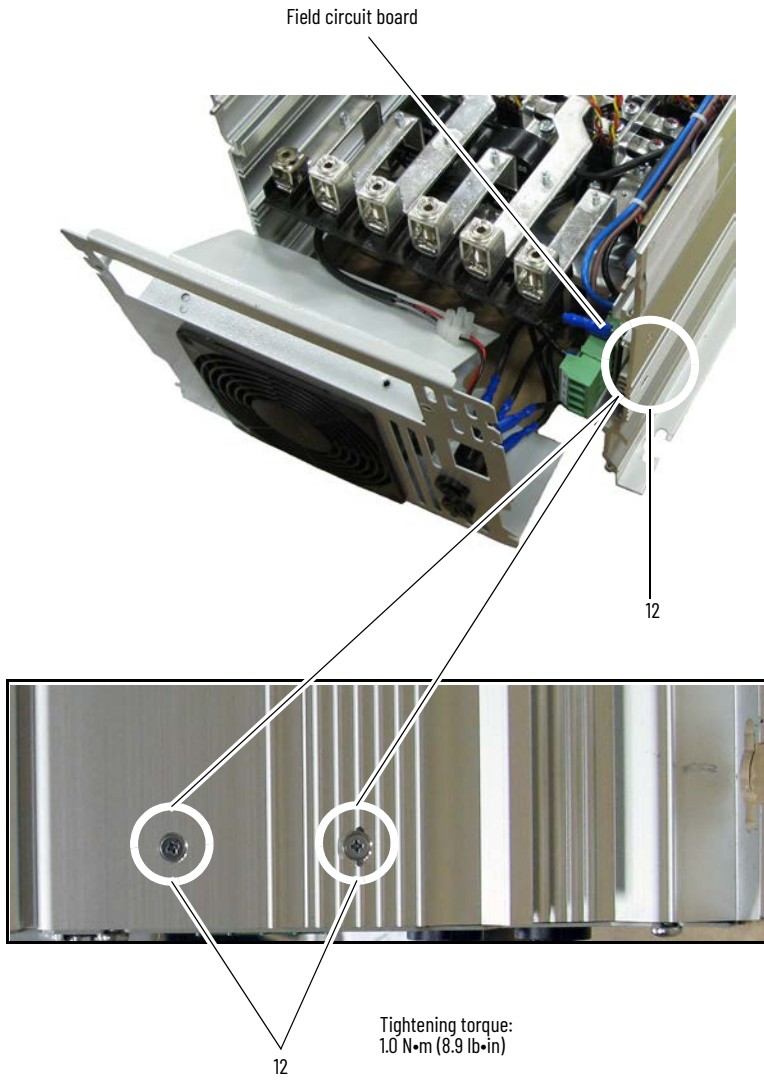

13. Remove the wires that connect the field fuses (UF, UF1, VF, VF1) to the field circuit board.
14. Remove the wire from connector X3 on the field board.

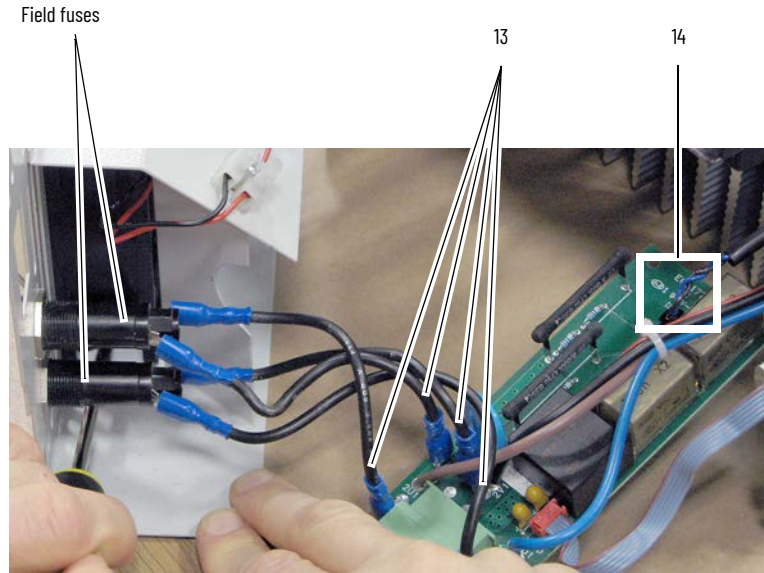

Install the Field SCR/Dual Diode Module and Field Circuit Board

- Install the field SCR/dual diode bridge module and field circuit board in reverse order of removal.

IMPORTANT Thermal grease must be applied to the bottom of the field SCR/dual diode module before securing it to the heat sink.

IMPORTANT Verify that the field circuit wires are connected to the correct location on the field SCR/dual diode module.

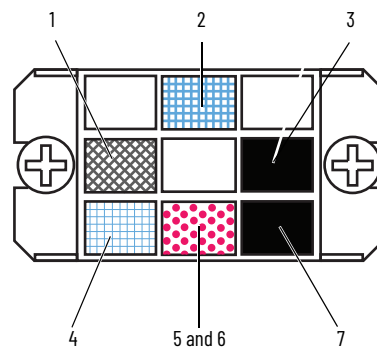

ID	Wire Description	Signal
1	Thick brown	To field circuit board
2	Thick blue	To field circuit board
3	Thick black	To field circuit board
4	Thin blue	

ID	Wire Description	Signal
5	Thick red	To field circuit board
6	Thin red	
7	Thin black	

Bimetal Thermostat Replacement

Remove the Bimetal Thermostat

Follow these steps to remove the bimetal thermostat.

1. Read the General Safety Precautions on page [9](#).
2. Remove power from the drive (see page [43](#)).
3. Remove the protective covers (see page [47](#)).
4. Remove the control EMI shield and control circuit board (see page [64](#)).
5. Remove the pulse transformer and switching power supply circuit boards (see page [67](#)).

IMPORTANT Mark all connections and wires before removal to avoid incorrect wiring during reassembly.

6. Remove the two M3 x 6 mm screws that secure the thermostat to the drive heat sink and remove the thermostat and connected wires from the drive.

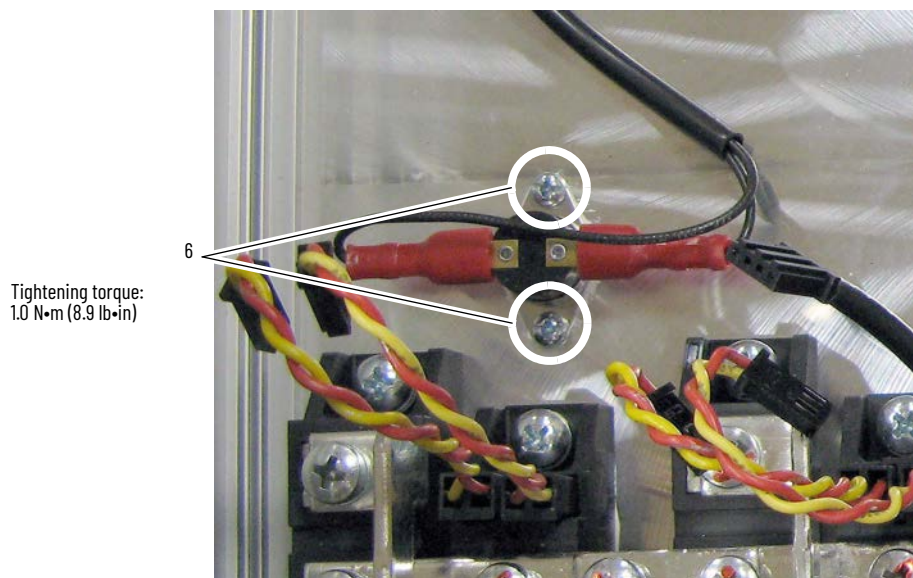

Install the Bimetal Thermostat

Install the thermostat in reverse order of removal.

IMPORTANT Thermal grease must be applied to the bottom of the thermostat before securing it to the heatsink.

SCR Module Replacement

Remove the SCR Modules

IMPORTANT For regenerative drives, the SCR modules must be replaced in pairs for each input phase in order that the gating resistance of each pair of modules is the same.

Follow these steps to remove the SCR modules.

1. Read the General Safety Precautions on page [9](#).
2. Remove power from the drive (see page [43](#)).
3. Remove the protective covers (see page [47](#)).
4. Remove the control EMI shield and control circuit board (see page [64](#)).
5. Remove the pulse transformer and switching power supply circuit boards (see page [67](#)).

The drive rating determines how the power bridge of the drive is configured and the steps that are required to remove the SCR modules:

- To remove the SCR modules from a frame A drive that is rated up to 55 A/15 Hp with 230V AC input or up to 52 A/30 Hp with 460V AC input, see SCR Modules on Drives Rated up to 55 A/15 Hp with 230V AC Input or up to 52 A/30 Hp with 460V AC Input on page [96](#).
- To remove the SCR modules from a frame A drive rated 73 A/20 Hp with 230V AC input and higher or 73 A/40 Hp with 460V AC input and higher, see SCR Modules on Drives Rated 73 A/20 Hp with 230V AC Input and Higher or 73 A/40 Hp with 460V AC Input and Higher on page [97](#).

SCR Modules on Drives Rated up to 55 A/15 Hp with 230V AC Input or up to 52 A/30 Hp with 460V AC Input

6. Remove the power traces circuit board. See Power Traces Circuit Board Replacement on page 85. In this case, do not remove the AC current transducers from the power traces board.
7. Remove the two screws and washers that secure each SCR module to the heat sink and remove the SCR modules.



Non-Regenerative drive

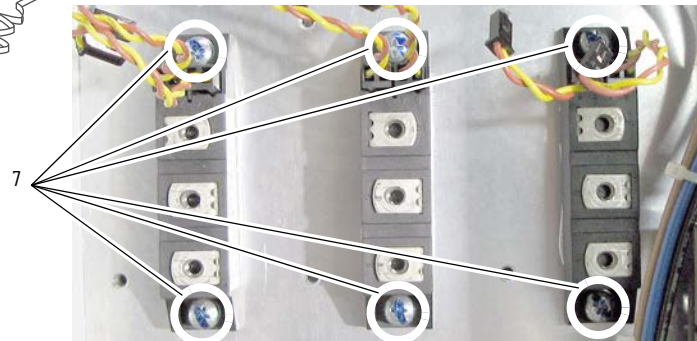

Regenerative drive

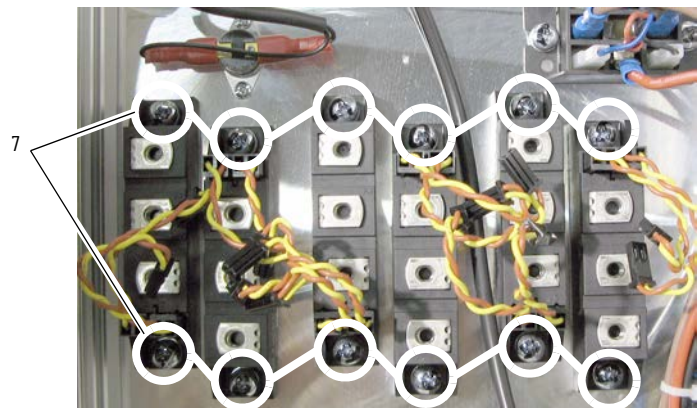

Continue with Install the SCR Modules on page 103.

SCR Modules on Drives Rated 73 A/20 Hp with 230V AC Input and Higher or 73 A/40 Hp with 460V AC Input and Higher

- 8. Remove the isolation sheet.

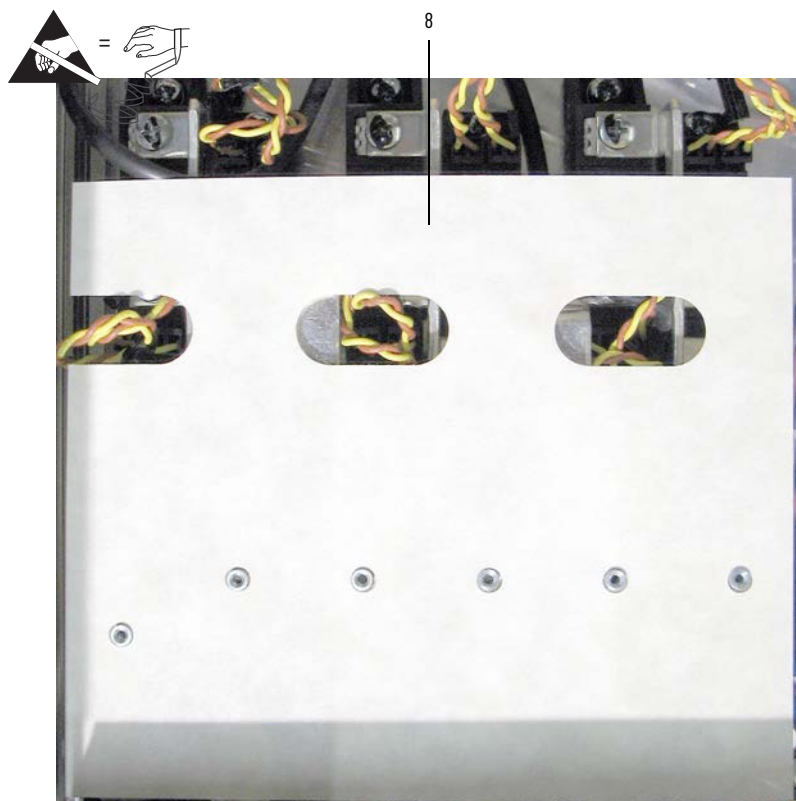

- 9. Remove the M5 x 10 mm screws that secure the U, V, W, C, and D terminal bus bars to the power terminal isolation strip at the bottom of the drive.

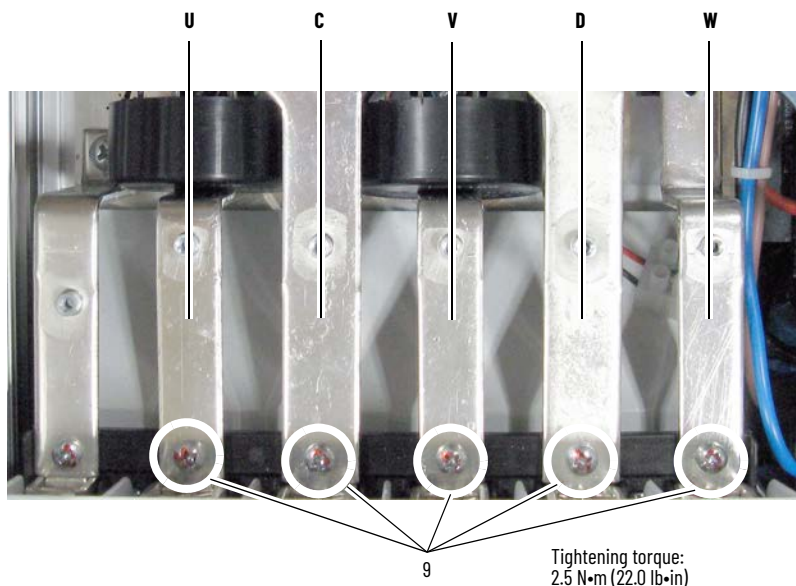

10. For regenerative drives only, remove the screws and washers that secure the connecting bus bars to the anodes of the corresponding SCR modules and remove the bus bars. In addition, remove the U, V, and W phase terminal bus bars from the drive.

IMPORTANT The screws that secure these bus bars to the SCR modules are M5 x 16. Retain for reuse with these bus bars only.

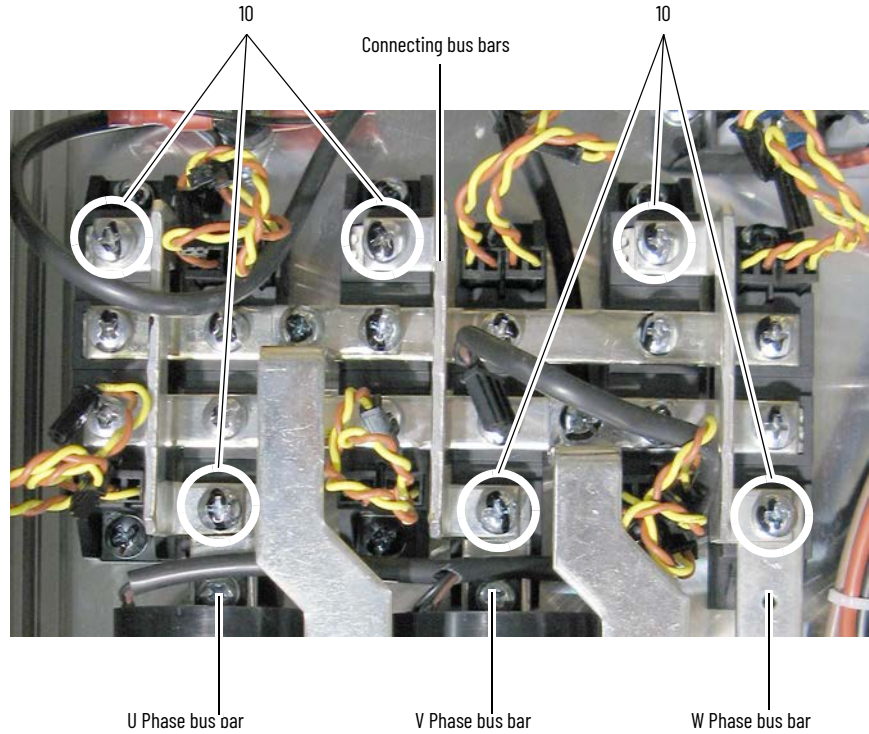

- 11. Remove the four screws and washers that secure the C and D terminal bus bars to the horizontal bus bars and remove the C and D terminal bus bars.

IMPORTANT For regenerative drives only, the screws that secure these bus bars to the SCR modules are M5 x 16. Retain for reuse with these bus bars only.

Non-Regenerative drive

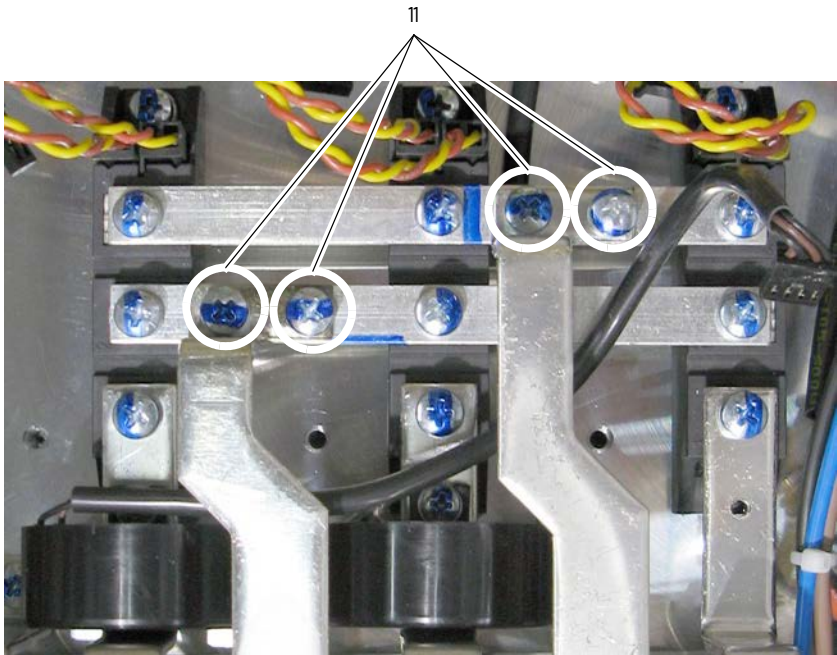

Regenerative drive

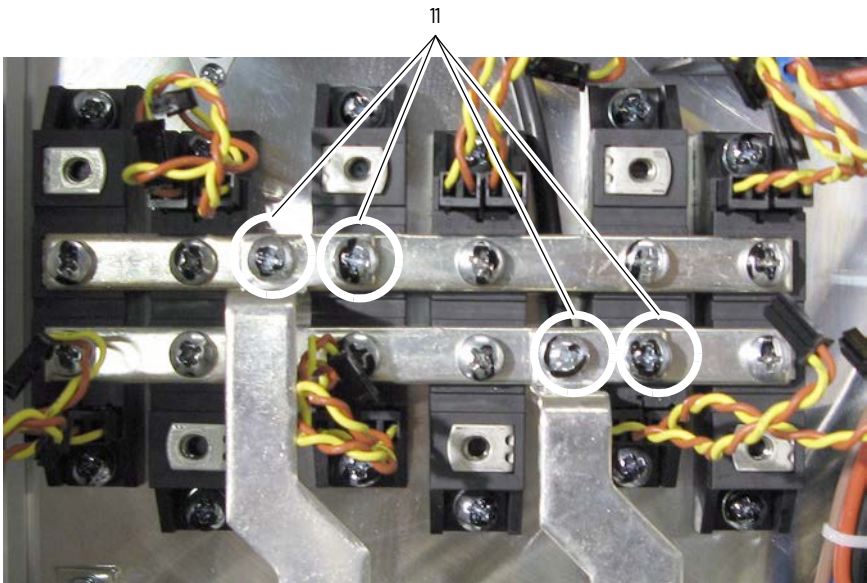

- 12. Remove the screws and washers that secure the connecting bus bars to the SCR modules and remove the bus bars.

Non-Regenerative drive

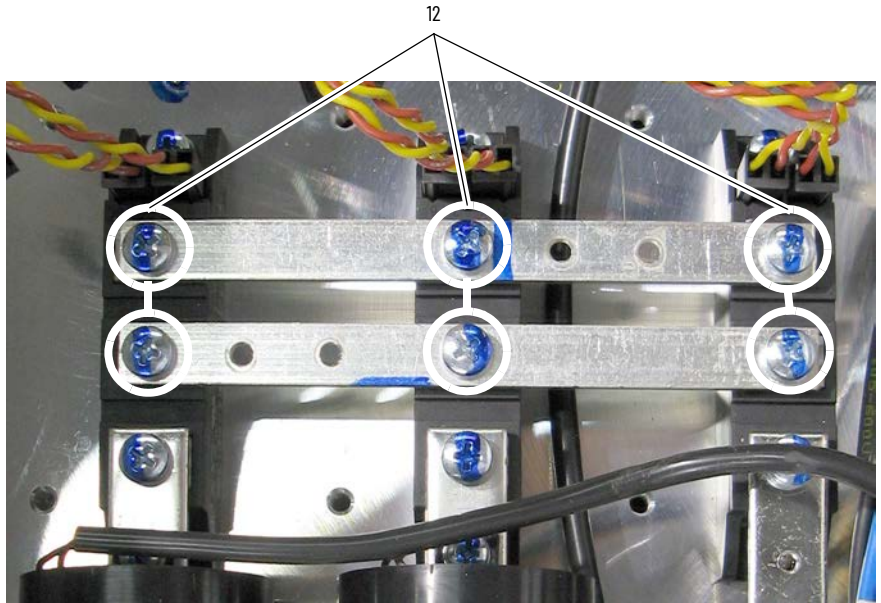

Regenerative drive

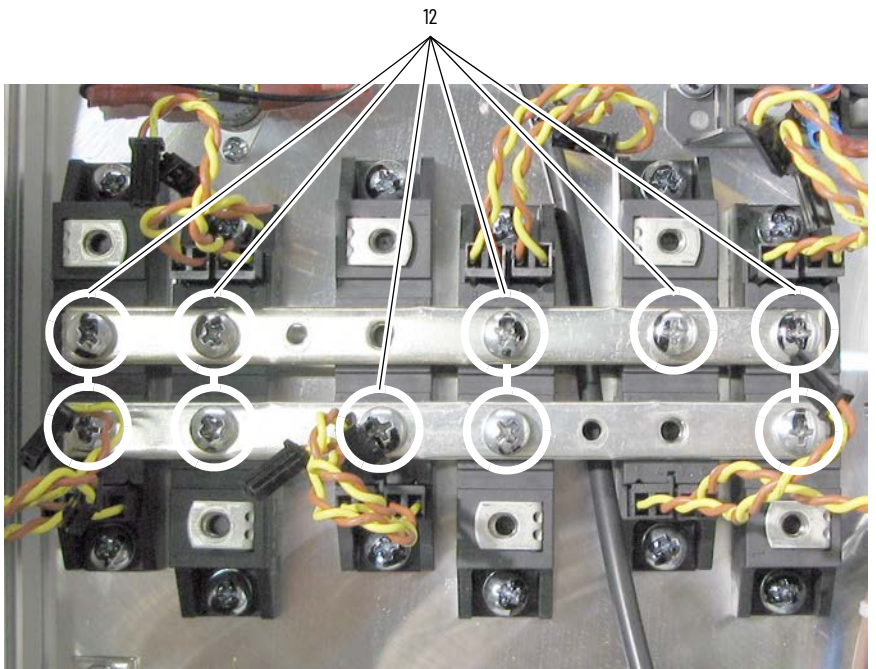

13. For non-regenerative drives only, remove the screws and washers that secure the U, V, and W terminal bus bars to the SCR modules and remove the bus bars.

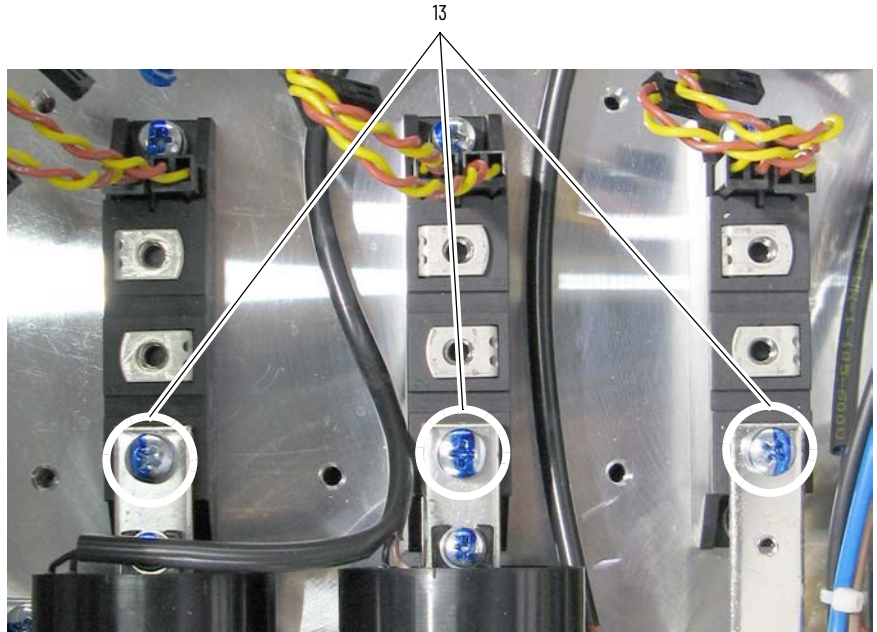

14. Remove the screws and washers that secure each SCR module to the heat sink and remove the SCR modules.

Non-Regenerative drive

14

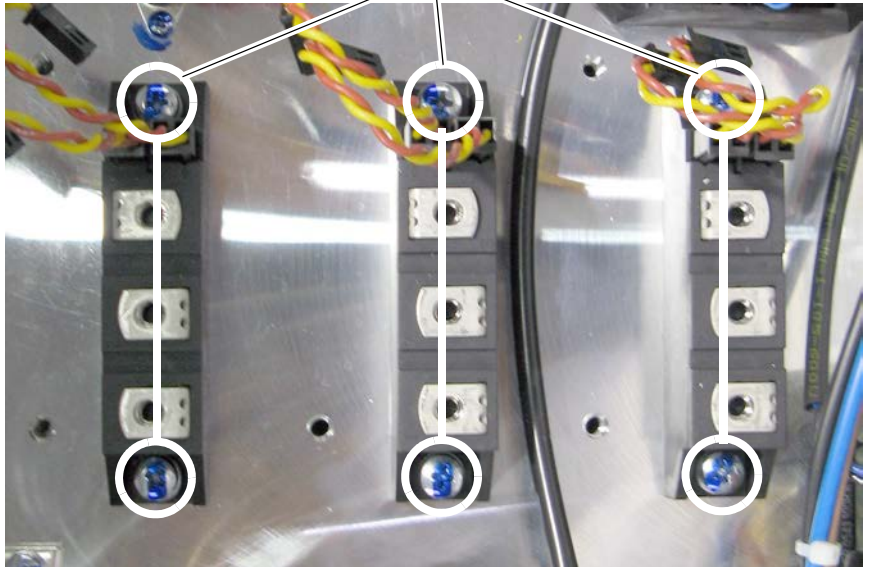

Regenerative drive

14

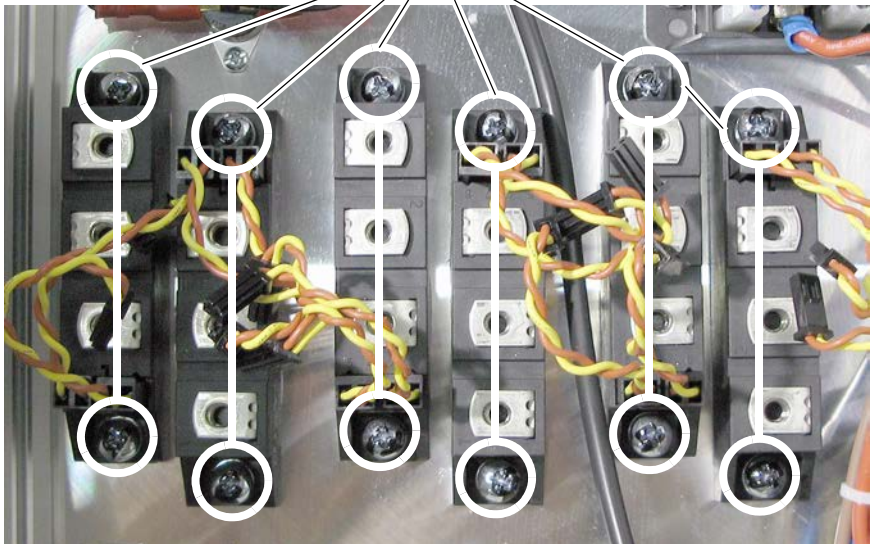

Install the SCR Modules

- Install the SCR modules in reverse order of removal using these tables for proper tightening torque.

IMPORTANT Thermal grease must be applied to the bottom of each SCR module before securing it to the heat sink.

Use the following table to determine the proper tightening torque for the SCR modules that are installed on the heat sink.

230V AC Input		460V AC Input	
Part Number	Final Torque	Part Number	Final Torque
SK-20P-S7F46	2.5...4 N•m (22...35.4 lb•in)	SK-20P-S7F75	2.5...4 N•m (22...35.4 lb•in)
SK-20P-S7F47	2.5...4 N•m (22...35.4 lb•in)	SK-20P-S7F77	2.5...4 N•m (22...35.4 lb•in)

Use the following table to determine the proper tightening torque for the bus bars to SCR modules connections.

230V AC Input		460V AC Input	
Part Number	Final Torque	Part Number	Final Torque
SK-20P-S7F46	2.5...4 N•m (22...35.4 lb•in)	SK-20P-S7F75	2.5...4 N•m (22...35.4 lb•in)
SK-20P-S7F47	2.5...4 N•m (22...35.4 lb•in)	SK-20P-S7F77	2.5...4 N•m (22...35.4 lb•in)

IMPORTANT Verify that the SCR modules are installed with the gate leads in the proper position. See [Figure 17](#) on page [113](#) and [Figure 18](#) on page [113](#) for SCR gate lead pinouts.

Cooling Fan Replacement

Remove the Cooling Fan

Follow these steps to cooling fan.

1. Read the General Safety Precautions on page [9](#).
2. Remove power from the drive (see page [43](#)).

The drive rating determines where the cooling fan (if any) is located in/on the drive:

- See Cooling Fan on Drives Rated 38 A/10 Hp and 55 A/15 Hp with 230V AC Input and 35 A/20 Hp, 45 A/25 Hp, and 52 A/30 Hp with 460V AC Input on page [104](#).
- See Cooling Fan on Drives Rated 73 A / 20 Hp with 230V AC Input and 73 A / 40 Hp with 460V AC Input on page [105](#).

Cooling Fan on Drives Rated 38 A/10 Hp and 55 A/15 Hp with 230V AC Input and 35 A/20 Hp, 45 A/25 Hp, and 52 A/30 Hp with 460V AC Input

The following frame A drives have a cooling fan at the top of the chassis:

- 230V AC input: 38A/10 Hp and 55A/15 Hp
 - 460V AC input: 35A/20 Hp, 45A/25 Hp, and 52A/30 Hp
3. Remove the four screws that secure the slotted air flow plate and fan to the top of the drive. The fan is connected via a cable to the switching power supply board and therefore will not pull free from the drive until the cable is disconnected. See step 3 for instructions.

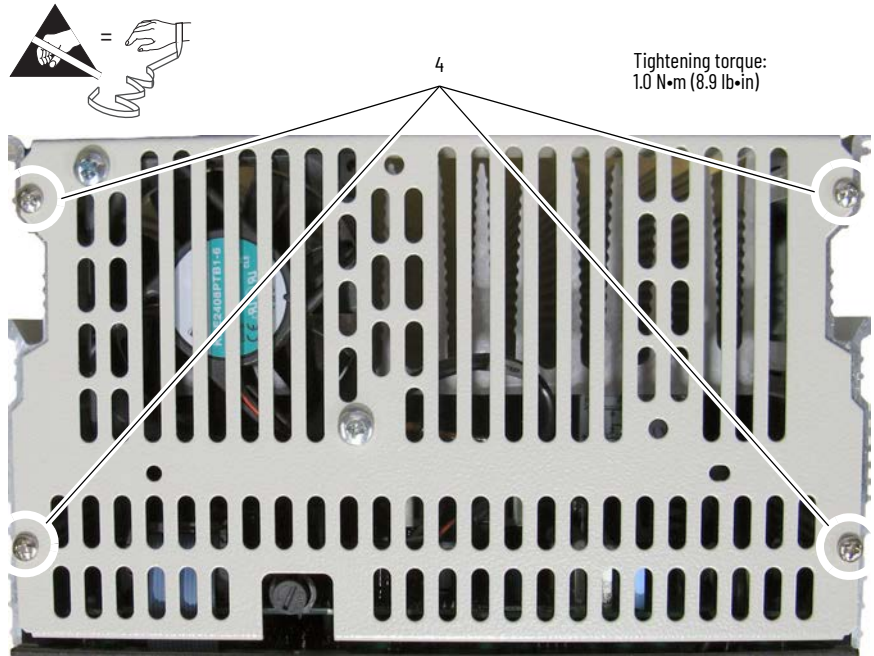

4. Disconnect the fan cable from connector XV on the switching power supply board and remove the fan and air flow plate.
5. Remove the twoM4 x 12.5 mm screws that secure the fan and spacers to the air flow plate and remove the fan.

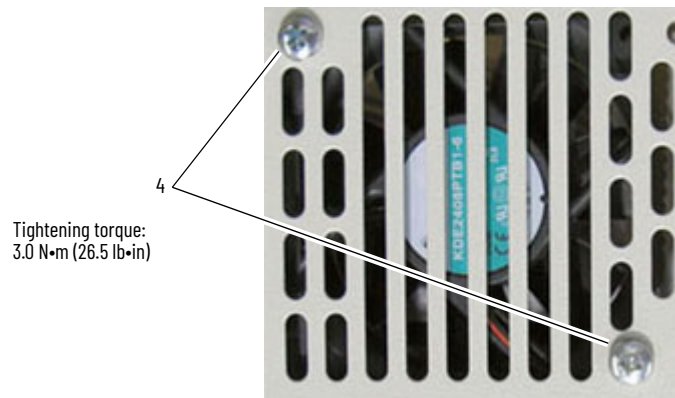

Continue with Install the Cooling Fan on page [107](#).

Cooling Fan on Drives Rated 73 A / 20 Hp with 230V AC Input and 73 A / 40 Hp with 460V AC Input

Frame A drives rated 73A/20 Hp with 230V AC and 73A/40 Hp with 460V AC and higher have a cooling fan that is installed on the bottom of the drive.

6. Loosen the two screws that secure the power terminal cover to the drive and slide the cover down and off the chassis.
7. Remove the field terminal block.
8. If necessary, remove the power wiring from the drive terminals.

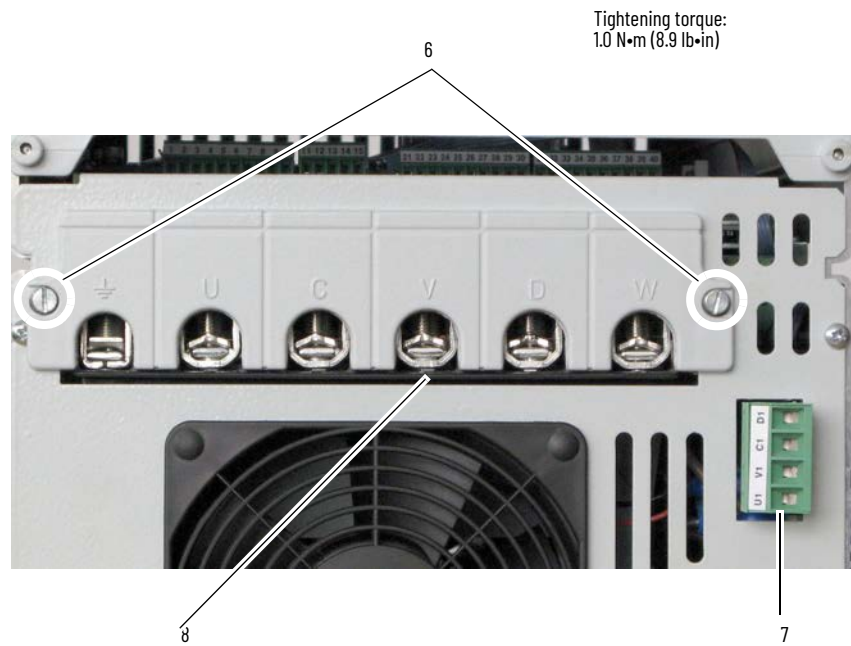

9. Remove the two screws that secure the armature-voltage feedback terminal block to the air flow plate and remove the terminal block.
10. Remove the six M4 x 12.5 mm screws that secure the air flow plate to the bottom of the drive chassis.
11. Carefully pull the air flow plate and fan assembly down and off the drive.

IMPORTANT Mark all connections and wires before removal to avoid incorrect wiring during reassembly.

12. Disconnect the (black and red) wires from the fan terminal block on the air flow plate.

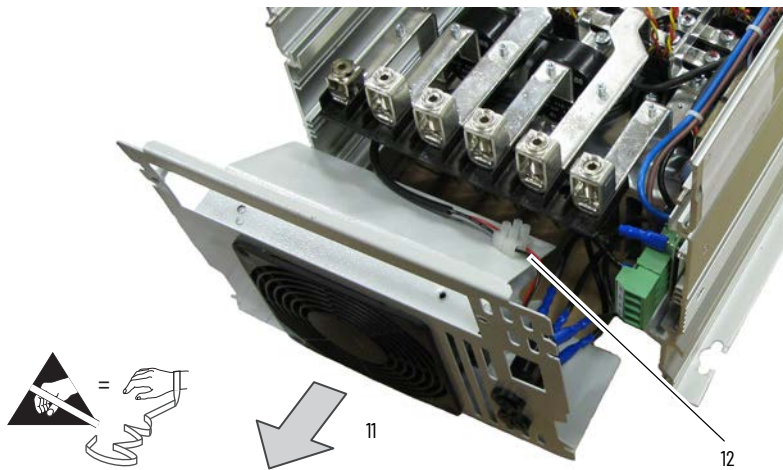
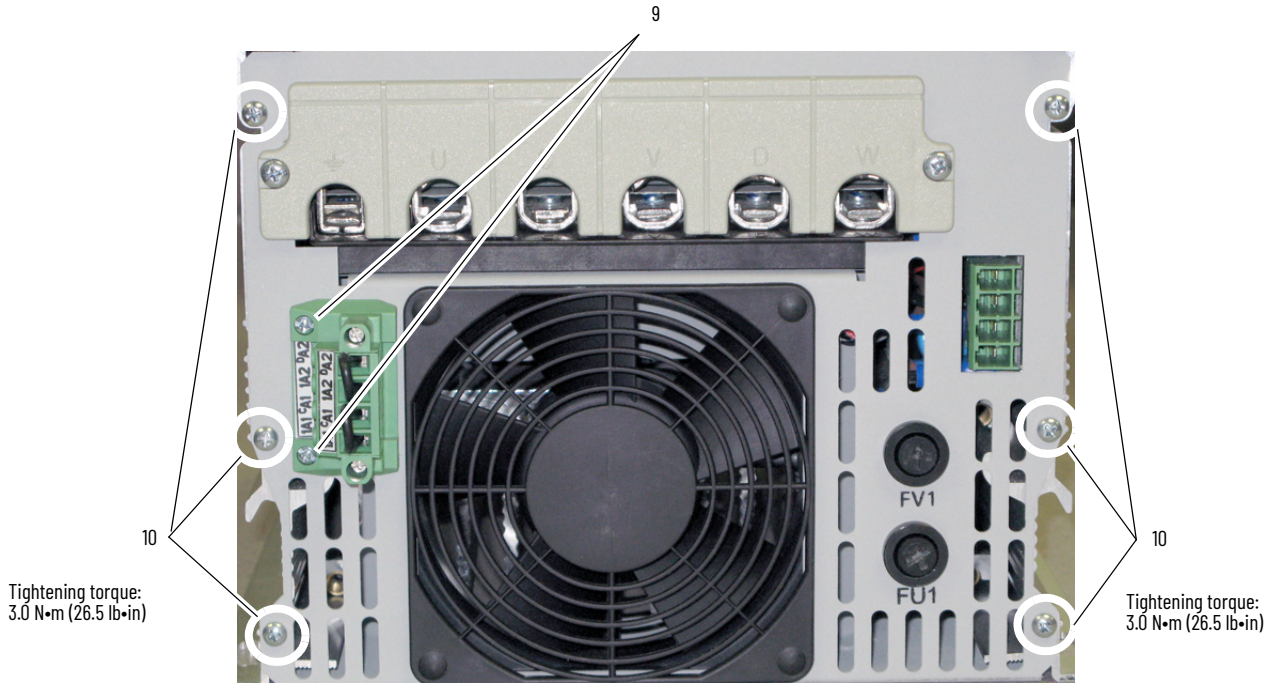

13. Using a flathead screwdriver, pry the fan cover plate off the air flow plate.
14. Slide the fan out of the air flow housing.

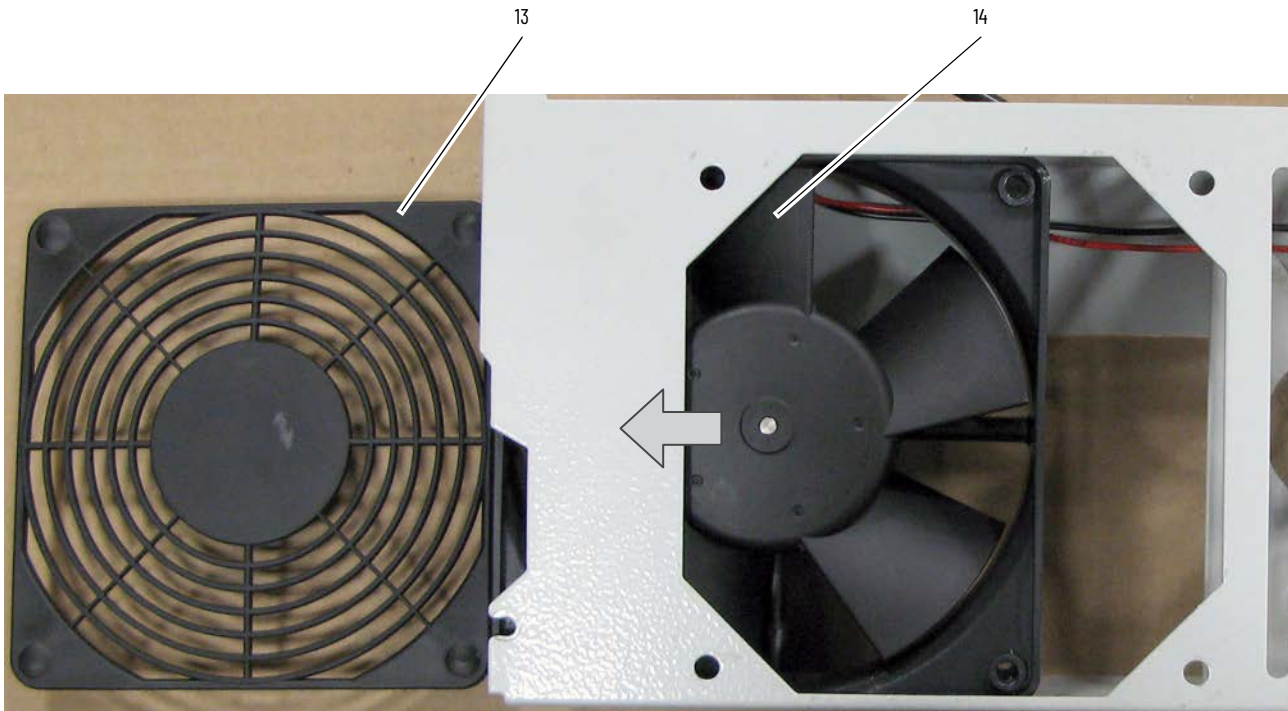

Install the Cooling Fan

Install the cooling fan in reverse order of removal.

IMPORTANT For both drive/fan configurations, verify that the air flow arrow on the fan is pointed toward the top of the drive.

IMPORTANT For drives with a fan that is connected to the top air flow plate, verify that the two spacers are properly placed during installation.

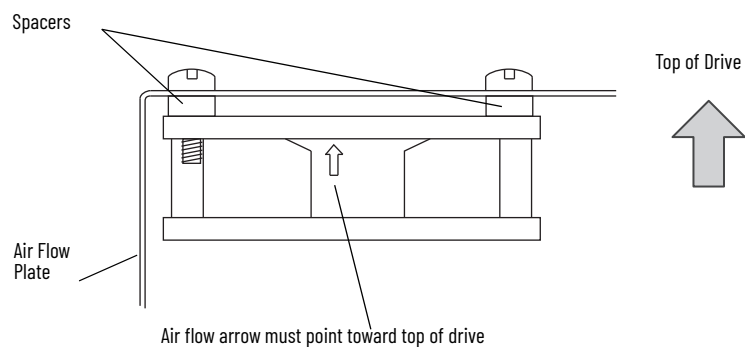

Notes:

Start Up After Repair

Before applying power to a repaired drive, perform the following tests:

- Check the Armature SCR Modules on page [28](#)
- Check the Field SCR/Dual Diode Module (Drives Only) on page [34](#)
- For drives, complete the Test With the Motor, Without a Mechanical Load

Test With the Motor, Without a Mechanical Load





This test allows you to measure several operating parameters and diagnose problems without connecting the motor to its mechanical load.

This procedure requires a HIM to configure and autotune the drive. If you prefer, you can use the DriveExecutive™ software.



ATTENTION: Power must be applied to the drive to perform the following start-up procedure. Some of the voltages present are at incoming line potential. To avoid electric shock hazard or damage to equipment, only qualified service personnel should perform the following procedure. Thoroughly read and understand the procedure before beginning. If an event does not occur while performing this procedure, **Do Not Proceed. Remove Power** including user supplied control voltages. User supplied voltages may exist even when main AC power is not applied to then drive. Correct the malfunction before continuing.

1. Verify that the input power wiring and grounding is connected.
2. Verify that the motor cables are connected.
3. Verify that the motor load is disconnected.
4. Verify that the control board DIP switches are set correctly. See [Install the Control Circuit Board on page 64](#) for more information.
5. Apply power to the control circuits (terminals U2 and V2) of the drive.
6. Verify that the following parameter values are set correctly:
 - 45 [Max Ref Speed] is set to the motor nameplate base speed.
 - 162 [Max Feedback Spd] is set to the motor nameplate base speed.
 - 175 [Rated Motor Volt] is set to the motor rated nameplate armature voltage.
 - 179 [Nom Mtr Arm Amps] is set to the rated motor nameplate armature current.
 - 280 [Nom Mtr fld Amps] is set to the rated motor nameplate field current.
 - 374 [Drv fld Brdg Amps] is set to the rated current of the field bridge regulator
7. Energize the drive.
8. Measure the field current and verify that the value is reflected in parameter 234 [Fld Current Pct].
9. Run the following applicable Autotune procedures detailed in Chapter 2 of the TPDFlex DC Converters User Manual publication 1S7TFLEXUM0
 - Tune the Current Regulator

- Verify Motor Rotation Direction and Run Feedback Polarity Checks. If parameter 414 [Fdbk Device Type] is set to 3 "Armature", set parameter 107 [Speed Zero Level] to a minimum value of 10% of base motor speed.
 - Configure the Speed Feedback Parameters
 - Tune the Speed Regulator
10. Make configuration changes that allow the HIM to issue start and speed commands.

 11. Start the drive, by pressing  (the start button).
If the drive will not start, verify that you have correctly installed any replacement components.
If any faults are displayed on the HIM, refer to Chapter 4 - Troubleshooting in the TPDflex DC Converters User Manual publication 1S7TFLEXUM0
 12. Increase the speed command from zero to base speed, by pressing  (the up button).
 13. Measure the output voltage and verify that it is reflected in parameter 233 [Output Voltage].
 14. Measure the armature current and verify that the value is reflected in parameter 199 [Arm Current Pct].
 15. Stop the drive, by pressing  (the stop button).
 16. If these measurements are correct, re-configure the drive to suit the application. Refer to Chapters 1 and 2 of the TPDflex DC Converters User Manual publication 1S7TFLEXUM0 for assistance.

If any of these measurements are incorrect, repeat steps 8...15. If the measurements are still incorrect, repeat the appropriate procedures in Chapter 2 - Component Test Procedures beginning on [page 13](#).

Schematics

List of Schematic Diagrams

Topic	Page
Figure 16 - Drive Interconnection Diagram	112
Figure 17 - Non-regenerative Drive Power Module Diagram	113
Figure 18 - Regenerative Drive Power Module Diagram	113
Figure 19 - AC Line Measurement Points Diagram	115
Figure 20 - Power Feedback Connections Diagram	115
Figure 21 - SCR to Pulse Transformer Board Gate Lead Pinout - Regenerative Drive Diagram	116
Figure 22 - SCR to Pulse Transformer Board Gate Lead Pinout - Non-regenerative Drive Diagram	116
Figure 23 - Field Board and SCR/Dual Diode Module Connections Diagram	117
Figure 24 - Field Control Circuit Diagram	117
Figure 25 - Control Circuit Input Power Diagram	118
Figure 26 - Encoder Control Circuit Diagram	118
Figure 27 - DC Tachometer Control Circuit Diagram	119
Figure 28 - Motor Thermal Protection Control Circuit Diagram	119
Figure 29 - Drive Heat Sink Monitoring Control Circuit Diagram	120
Figure 30 - Contactor Control Relays Control Circuit Diagram	120

Figure 16 - Drive Interconnection Diagram

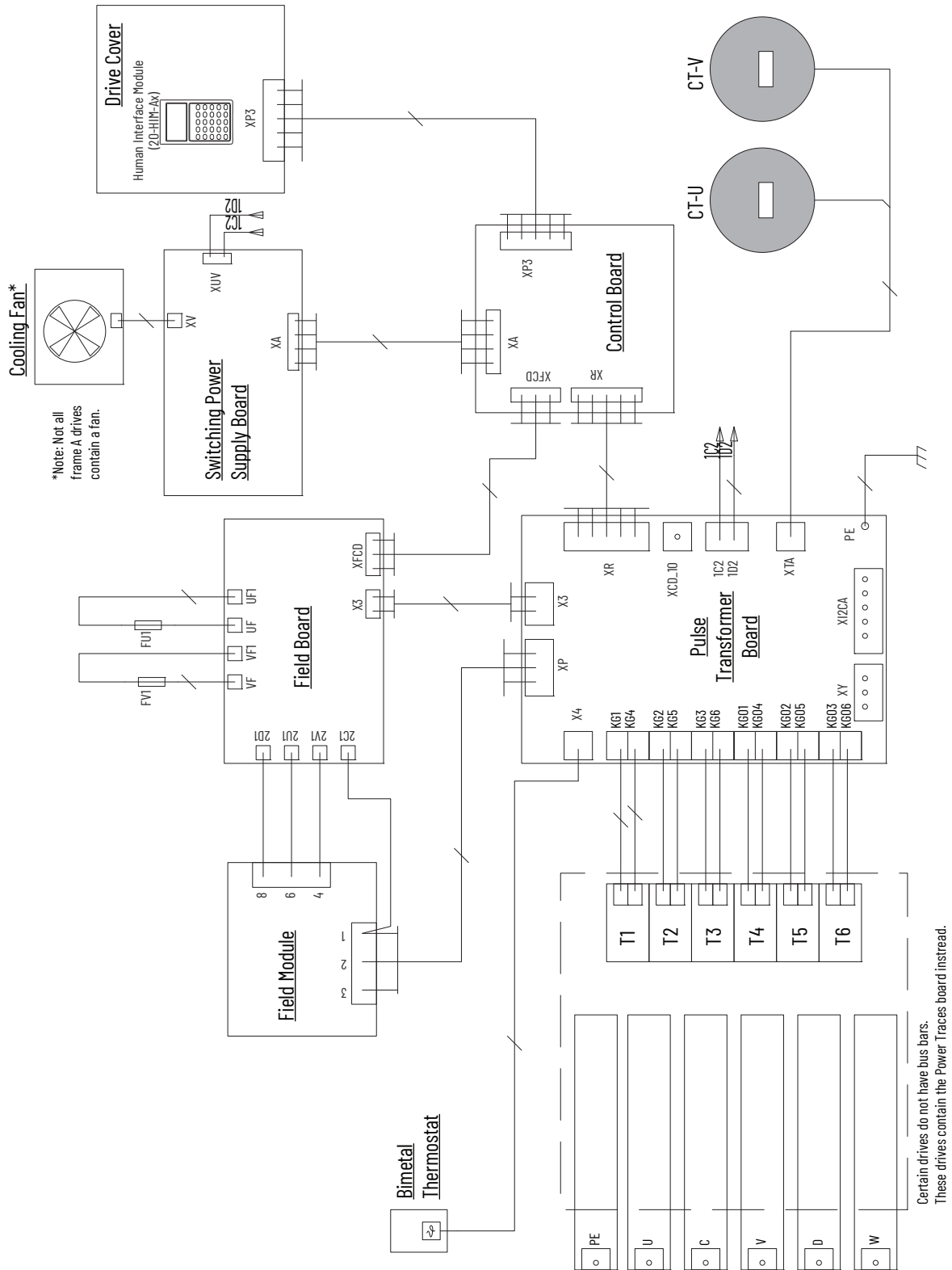

Figure 17 - Non-regenerative Drive Power Module Diagram

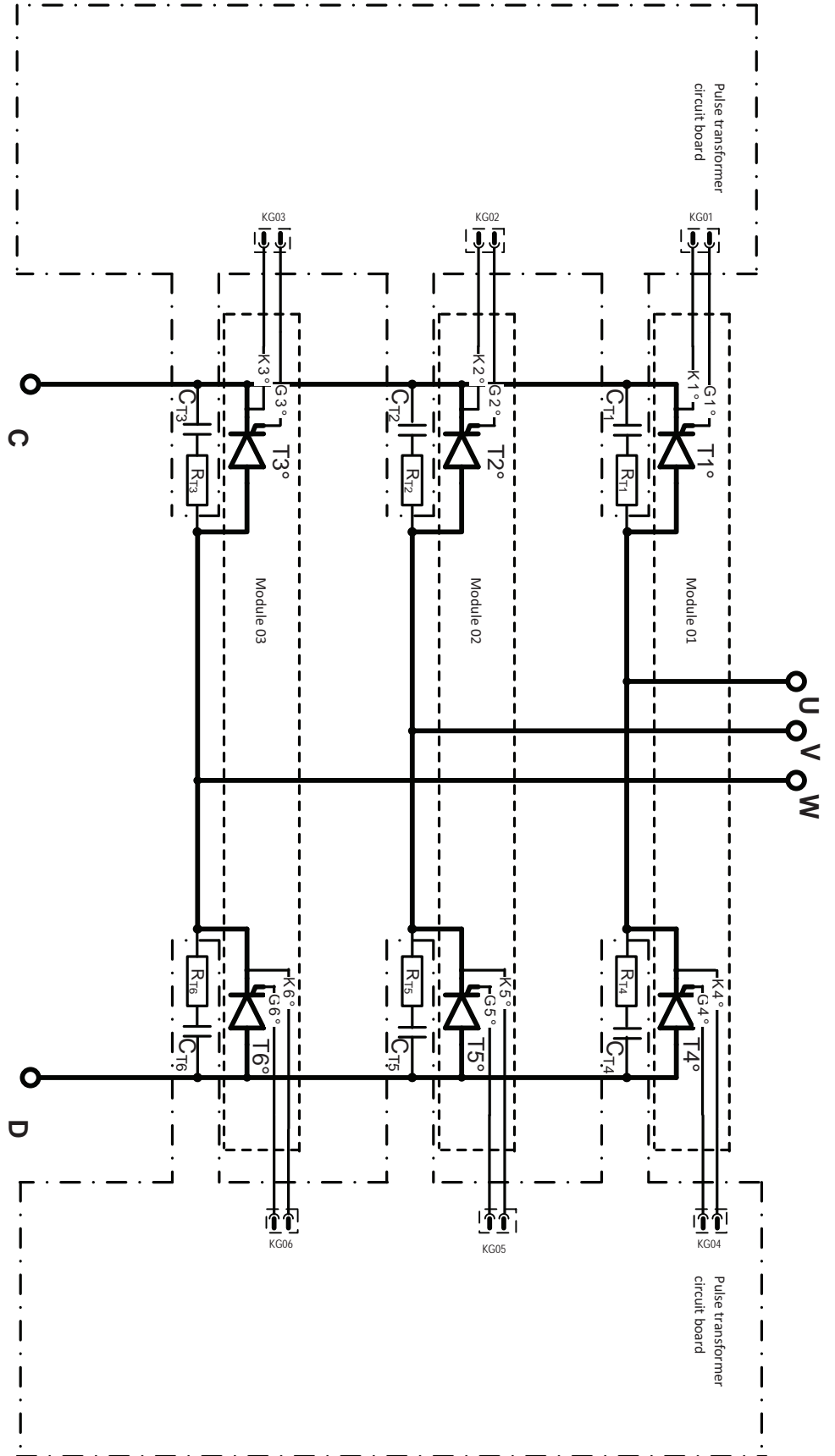

Figure 18 - Regenerative Drive Power Module Diagram

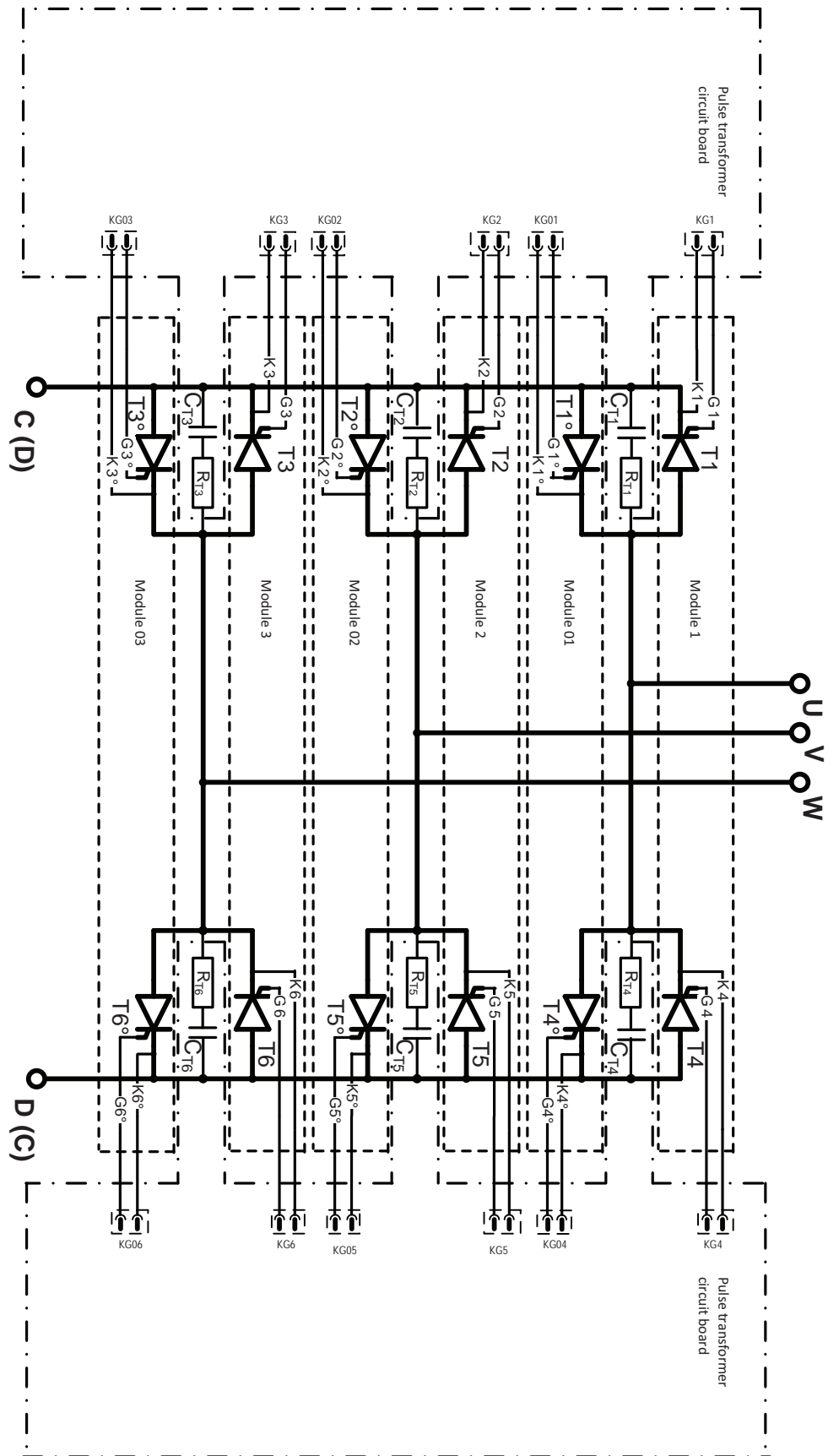

Figure 19 - AC Line Measurement Points Diagram

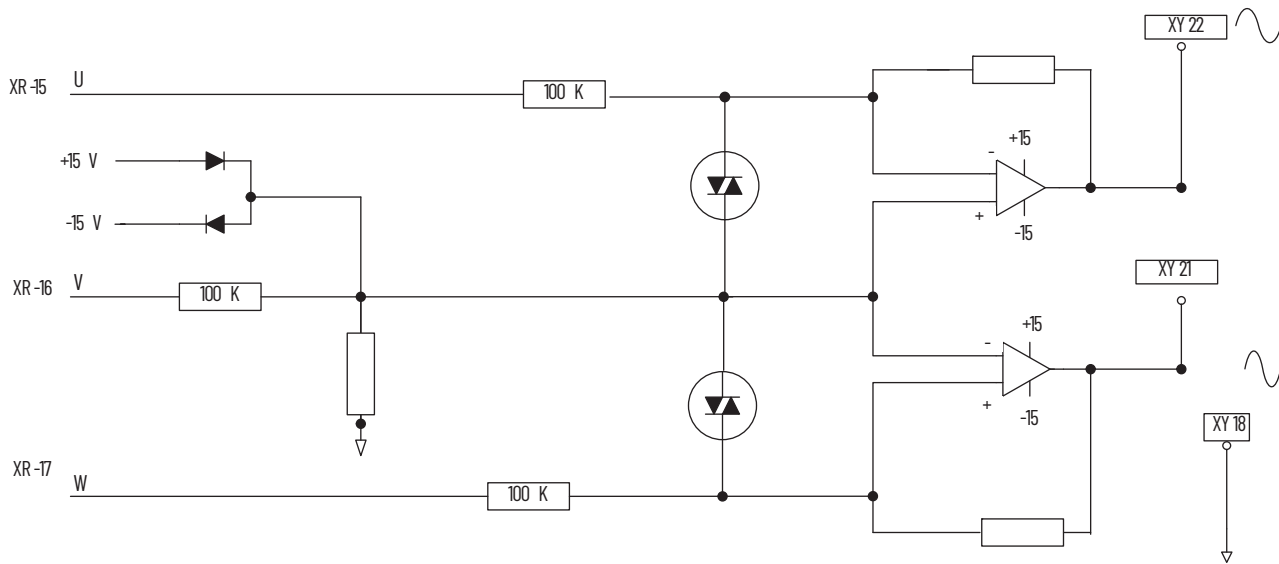
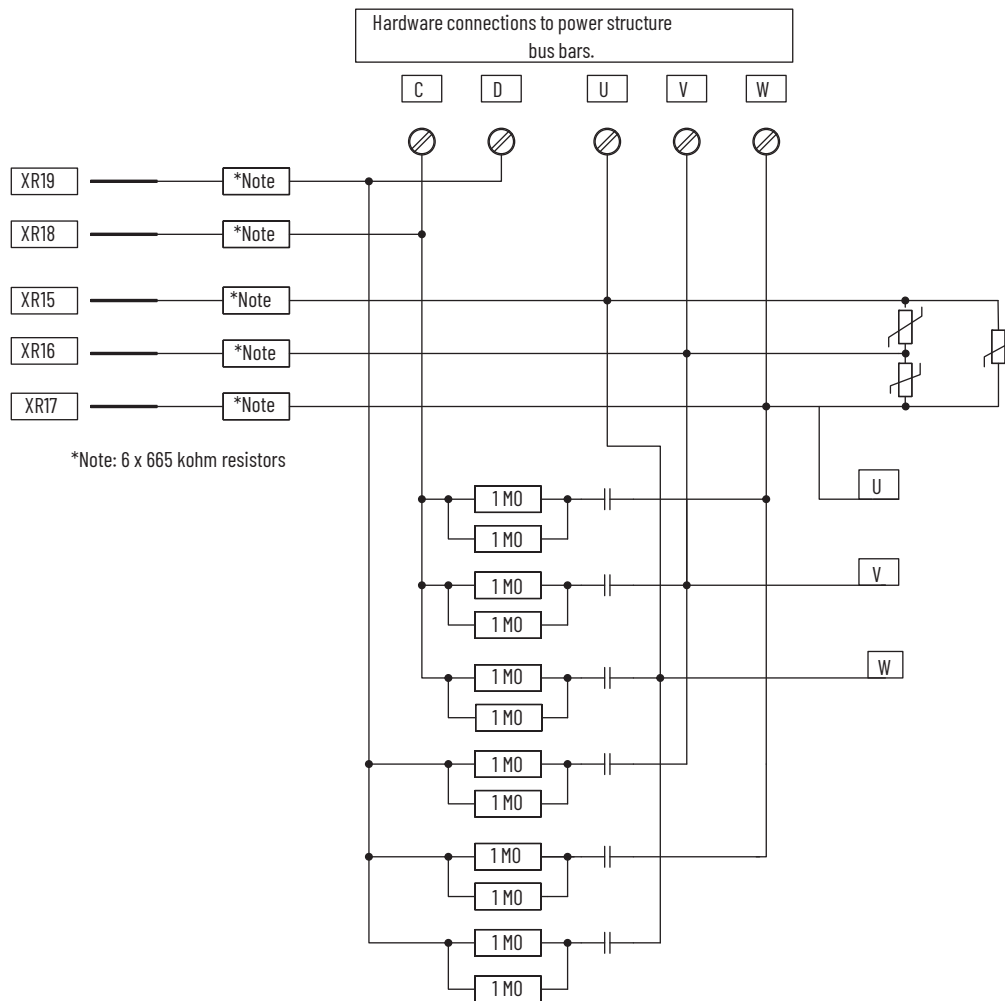

Figure 20 - Power Feedback Connections Diagram



*Note: 6 x 665 kohm resistors

Figure 21 - SCR to Pulse Transformer Board Gate Lead Pinout - Regenerative Drive Diagram

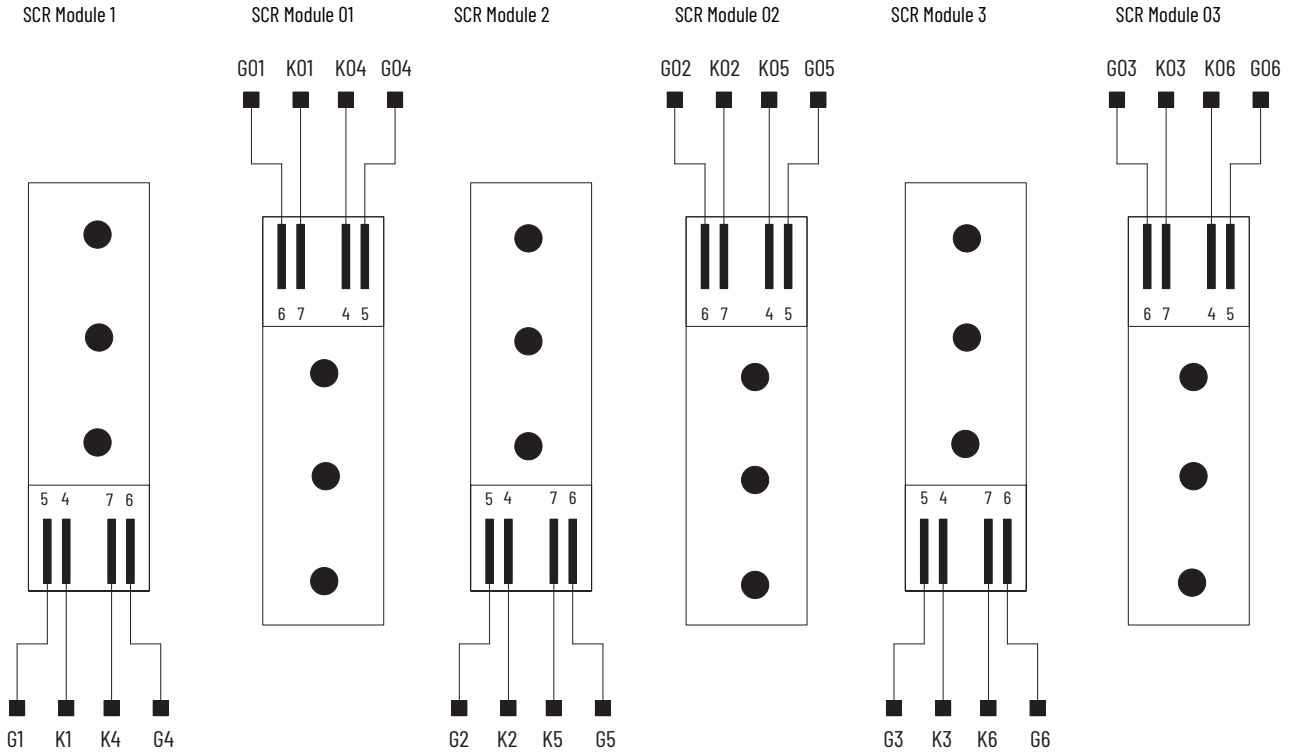

Figure 22 - SCR to Pulse Transformer Board Gate Lead Pinout - Non-regenerative Drive Diagram

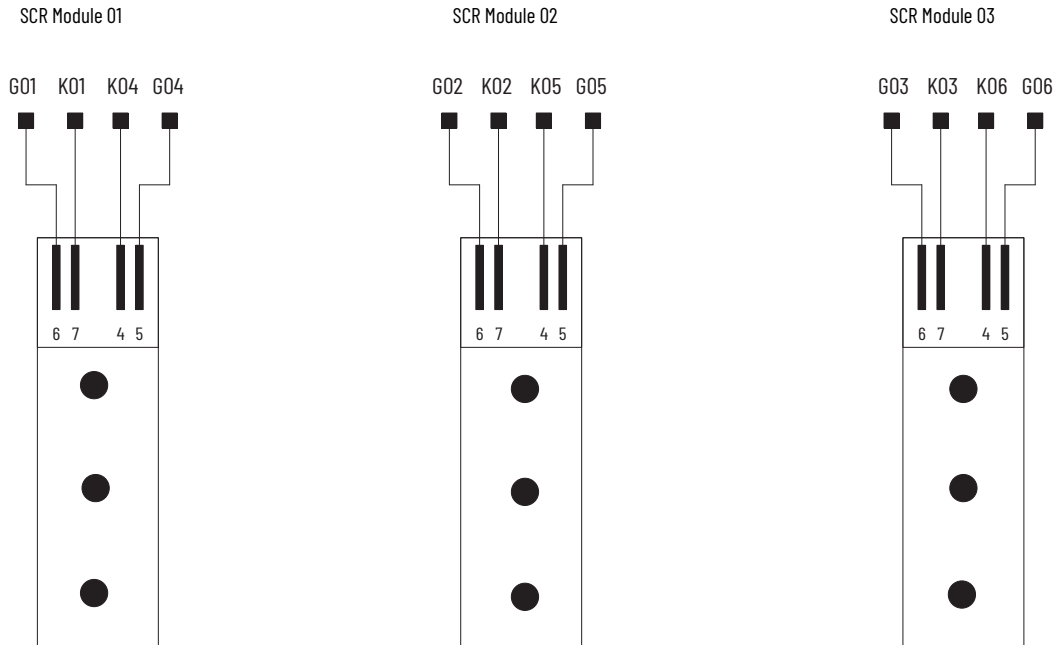

Figure 25 - Control Circuit Input Power Diagram

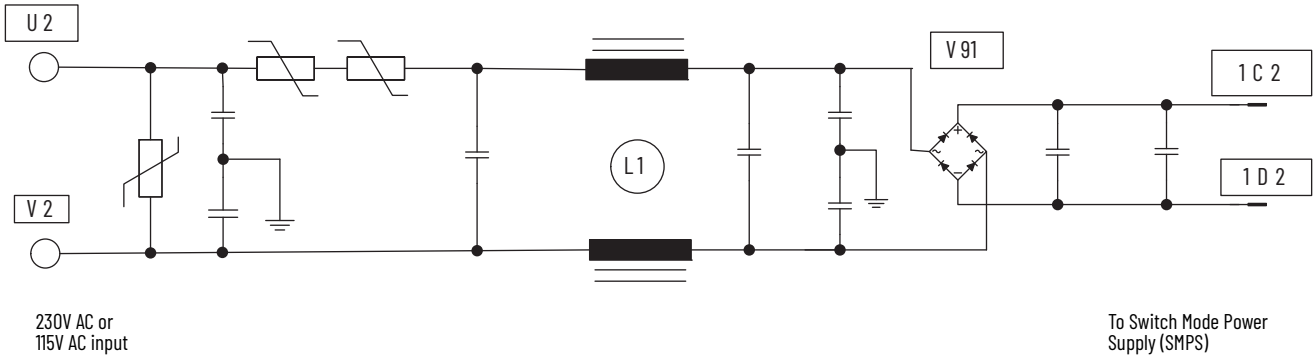

Figure 26 - Encoder Control Circuit Diagram

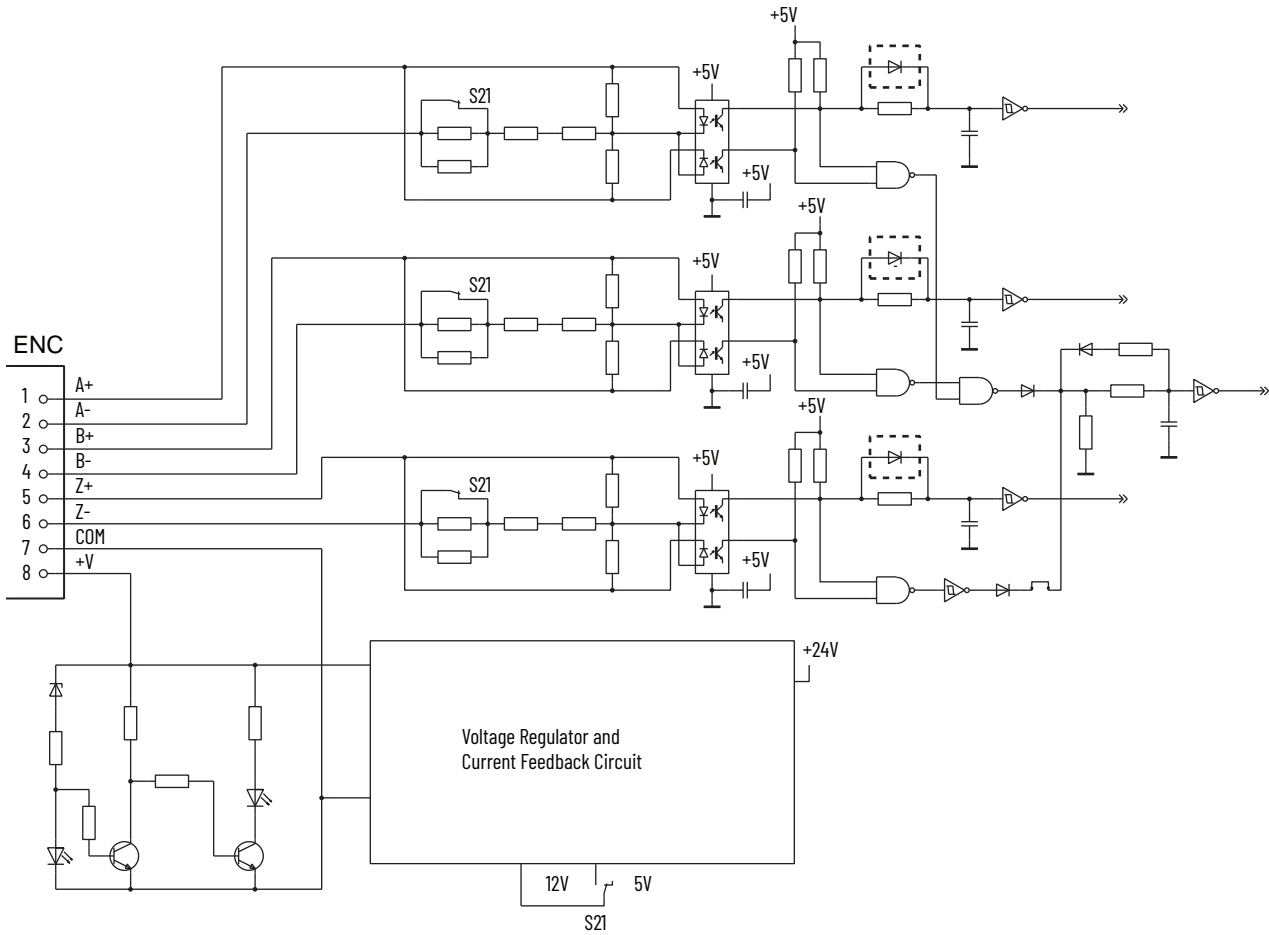

Figure 27 - DC Tachometer Control Circuit Diagram

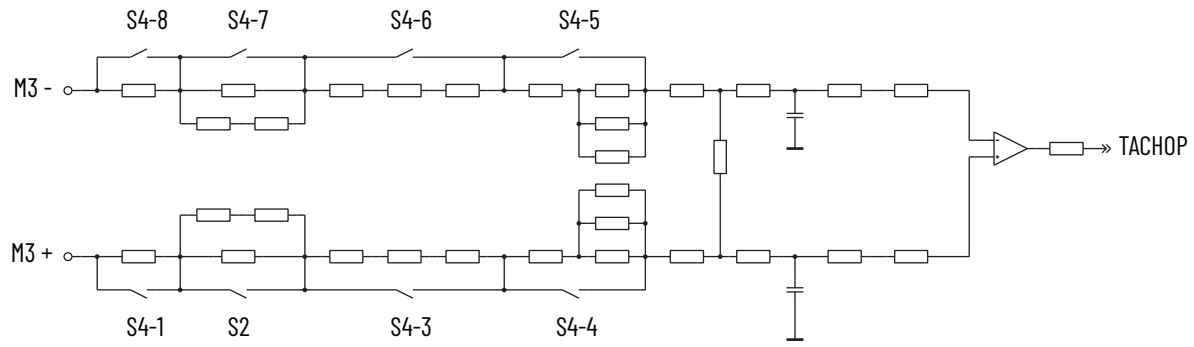

Figure 28 - Motor Thermal Protection Control Circuit Diagram

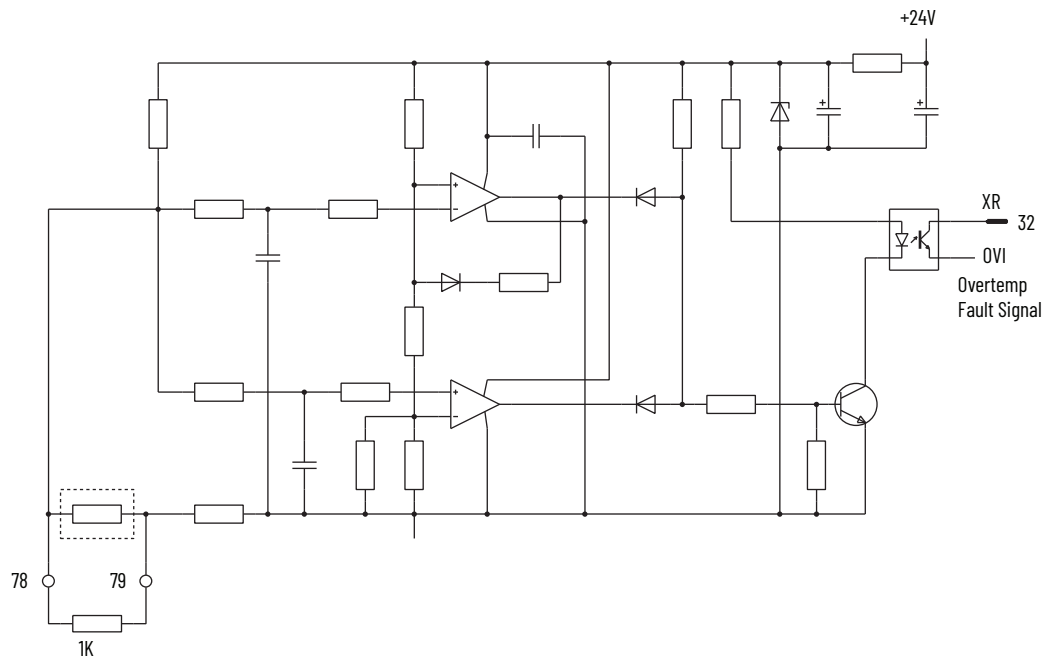

Figure 29 - Drive Heat Sink Monitoring Control Circuit Diagram

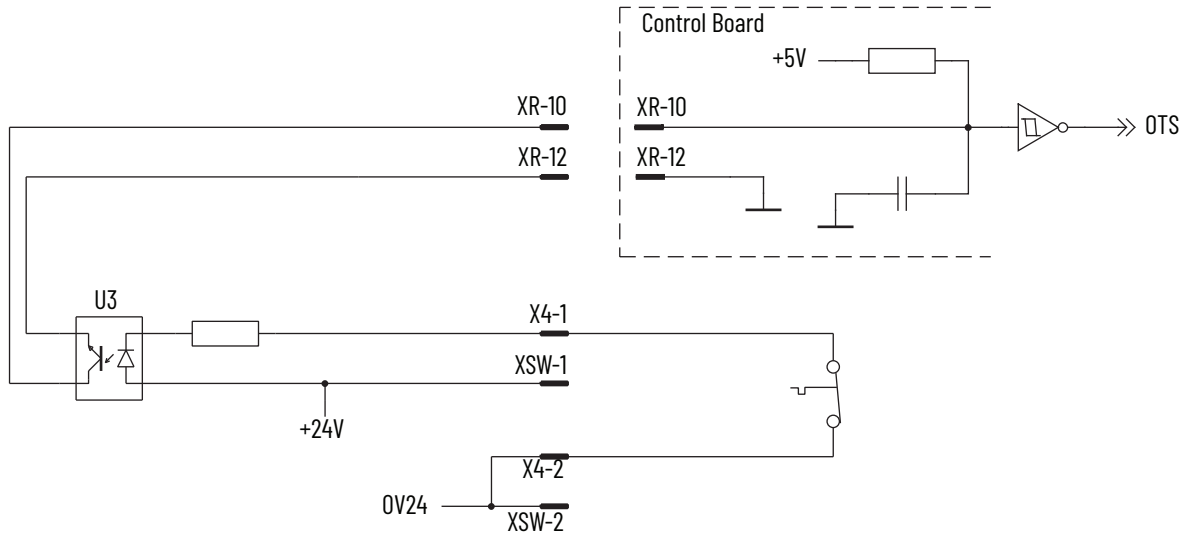
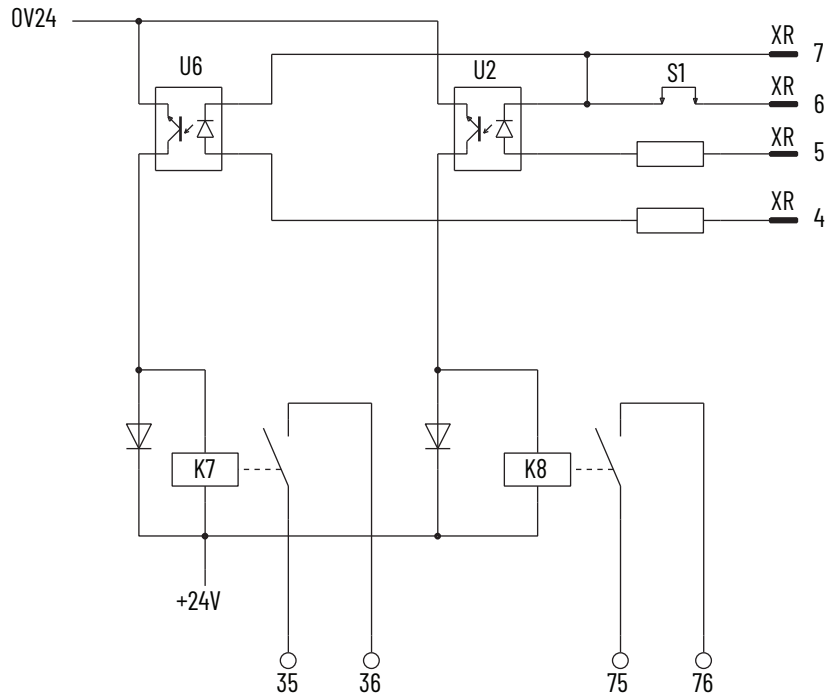

Figure 30 - Contactor Control Relays Control Circuit Diagram



Circuit Board Layouts and Connections

List of Circuit Board Layouts

The following images and tables detail the connection points for the frame A TPDflex DC Converter circuit boards and components.

Topic	Page
Pulse Transformer Board Layout	122
Pulse Transformer Board to Field Board Connections	123
Pulse Transformer Board to Switching Power Supply Connections	123
Pulse Transformer Board to Bimetal Thermostat Connections	123
Pulse Transformer Board to Field SCR/Dual Diode Module Connections	123
Pulse Transformer Board to Control Board Connections	124
Pulse Transformer Board to Current Transducer Connections	124
Switching Power Supply Board Layout	125
Switching Power Supply to Fan Connections	125
Switching Power Supply Board to Control Board Connections	125
Control Board Layout	126
Control Board to Field Board Connections Series A	126
Field Board Layout	128

Pulse Transformer Board

Figure 31 - Pulse Transformer Board Layout

Components shown within dashed lines are only on the pulse transformer board for regenerative drives.



Table 19 - Pulse Transformer Board to Field Board Connections

Pulse Transformer Board Connector	Pin Number	to	Pin Number	Field Board Connector	Description
X3	1	...	1	X3	1U1 field sync signal (from U1)
	2	...	2		1V1 field sync signal (from V1)

Table 20 - Pulse Transformer Board to Switching Power Supply Connections

Pulse Transformer Board Point	to	Pin Number	Switching Power Supply Board Connector	Description
1C2	...	4	XUV	Rectified U2-V2 voltage (approx. 150/300V DC)
	...	3		not used
1D2	...	2		not used
	...	1		Common

Table 21 - Pulse Transformer Board to Bimetal Thermostat Connections

Pulse Transformer Board Connector	Pin Number	to	Pin Number	Bimetal Thermostat Connector	Description
X4	1	...	1	X4	+24V supply through resistor
	2	...	2		24V common

Table 22 - Pulse Transformer Board to Field SCR/Dual Diode Module Connections

Pulse Transformer Board Connector	Pin Number	to	Pin Number	Field SCR/Dual Diode Module Connector	Description
XP	1	...	3	Fastons	Gate signal G1
	2	...	2		Common cathode (K1 and K2) for both field SCRs
	3	...	2		
	4	...	1		Gate signal G2

Table 23 - Pulse Transformer Board to Control Board Connections

Pulse Transformer Board Connector	Pin Number	to	Pin Number	Control Board Connector	Description
XR	1	...	1	XR	Gate signal G1 field SCR1
	2	...	2		Gate signal G2 field SCR2
	3	...	3		OV (GNDP)
	4	...	4		Relay output 35-36 command
	5	...	5		Relay output 75-76 command
	6	...	6		2Q/4Q selection signal
	7	...	7		OV (GNDP)
	8	...	8		I armature = 0 signal
	9	...	9		OV (GNDP)
	10	...	10		Heat sink over temperature
	11	...	11		Digital U1-V1 sync signal
	12	...	12		OV (GNDP)
	13	...	13		CT burden signal
	14	...	14		OV (GND)
	15	...	15		Reduced U sync signal
	16	...	16		Reduced V sync signal
	17	...	17		Reduced W sync signal
	18	...	18		Reduced C (armature) signal
	19	...	19		Reduced D (armature) signal
	20	...	20		OV (GNDP)
	21	...	21		Gate signal SCR 4/01
	22	...	22		OV (GNDP)
	23	...	23		Gate signal SCR 5/02
	24	...	24		OV (GNDP)
	25	...	25		Gate signal SCR 6/03
	26	...	26		WH1 (not used, grounded)
	27	...	27		Gate signal SCR 1/04
	28	...	28		WL1 (not used, grounded)
	29	...	29		Gate signal SCR 2/05
	30	...	30		OV (GNDP)
	31	...	31		Gate signal SCR 3/06
	32	...	32		Motor overtemperature
	33	...	33		Enable reverse (MN) power bridge
	34	...	34		Enable forward (MP) power bridge

Table 24 - Pulse Transformer Board to Current Transducer Connections

Pulse Transformer Board Connector	Pin Number	to	Pin Number	Current Transducer	Description
XTA	1	...	Black	CT on Phase U	Secondary side CT phase U
	2	...	Brown		
	3	...	Black	CT on Phase V	Secondary side CT phase V
	4	...	Brown		

Switching Power Supply Board

Figure 32 - Switching Power Supply Board Layout

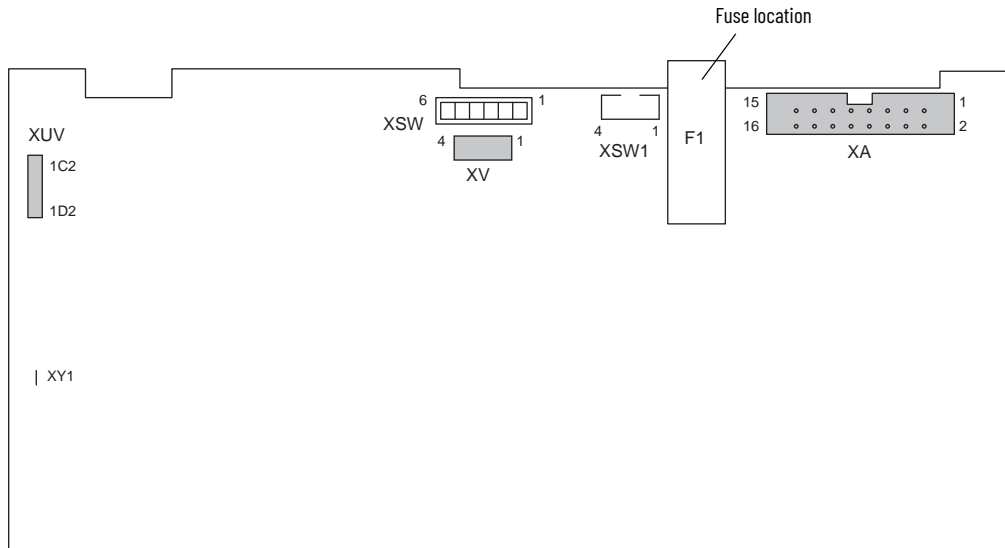

Table 25 - Switching Power Supply to Fan Connections

Control Board Connector	Pin Number	to	Pin Number	Fan Connector	Description
XV	1	...	1	XV	+24V
	2	...	2		24V supply common
	3	...	3		
	4	...	4		

Table 26 - Switching Power Supply Board to Control Board Connections

Switching Power Supply Board Connector	Pin Number	to	Pin Number	Control Board Connector	Description
XA	1	...	1	XA	+5V
	2	...	2		5V common
	3	...	3		+5V
	4	...	4		5V common
	5	...	5		+5V
	6	...	6		5V common
	7	...	7		SMPS supply input undervoltage
	8	...	8		
	9	...	9		+15V
	10	...	10		
	11	...	11		15V common
	12	...	12		
	13	...	13		-15V
	14	...	14		
	15	...	15		24V common
	16	...	16		+24V

See Pulse Transformer Board to Switching Power Supply Connections on page [123](#).

Control Board

Figure 33 – Control Board Layout

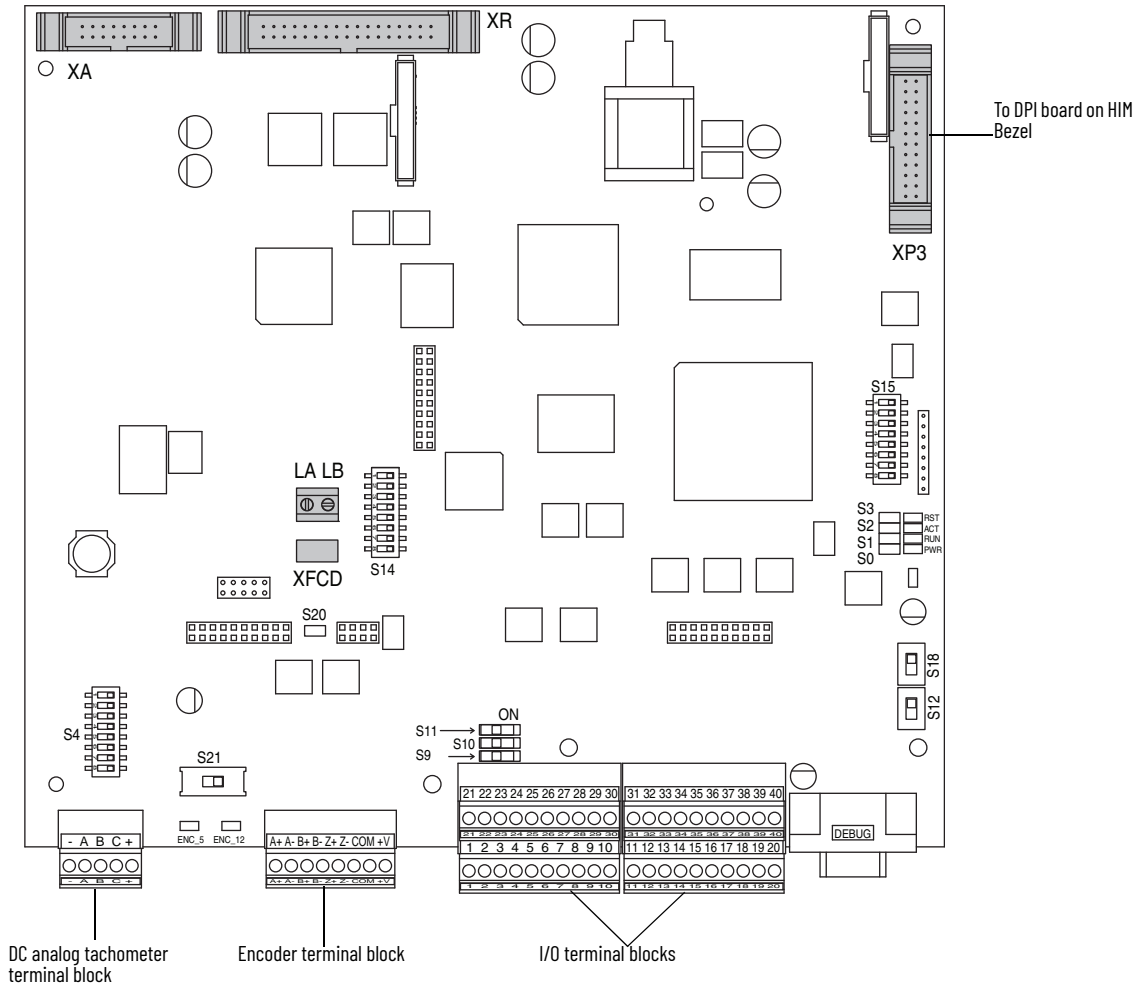

Series A

Table 27 - Control Board to Field Board Connections Series A

Control Board Connector	Pin Number	to	Pin Number	Field Board Connector	Description
XFCB	1	...	1	XFCB	+15V
	2	...	2		15V Common
	3	...	3		-15V
	4	...	4		Field CT burden resistors

See Pulse Transformer Board to Control Board Connections on page 124 and Switching Power Supply Board to Control Board Connections on page 125.

Field Board

Figure 34 - Field Board Layout

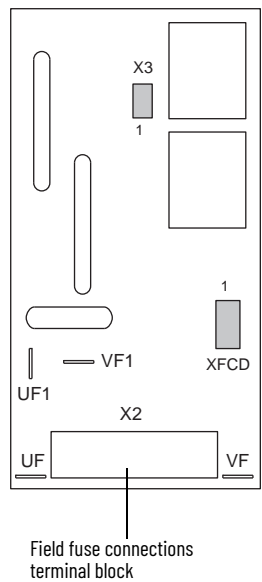

See Control Board to Field Board Connections Series A on page Control Board to Field Board Connections Series A and Pulse Transformer Board to Field Board Connections on page [123](#).

Flow Charts

List of Flow Charts

The following pages contain flow chart versions of troubleshooting procedures contained in Chapter 2 - Component Test Procedures.

Topic	Page
Control Power Supply Failure	130
Field Current Loss Failure	131

Control Power Supply Failure

This chart presents the steps for troubleshooting a Power Failure fault (F3).

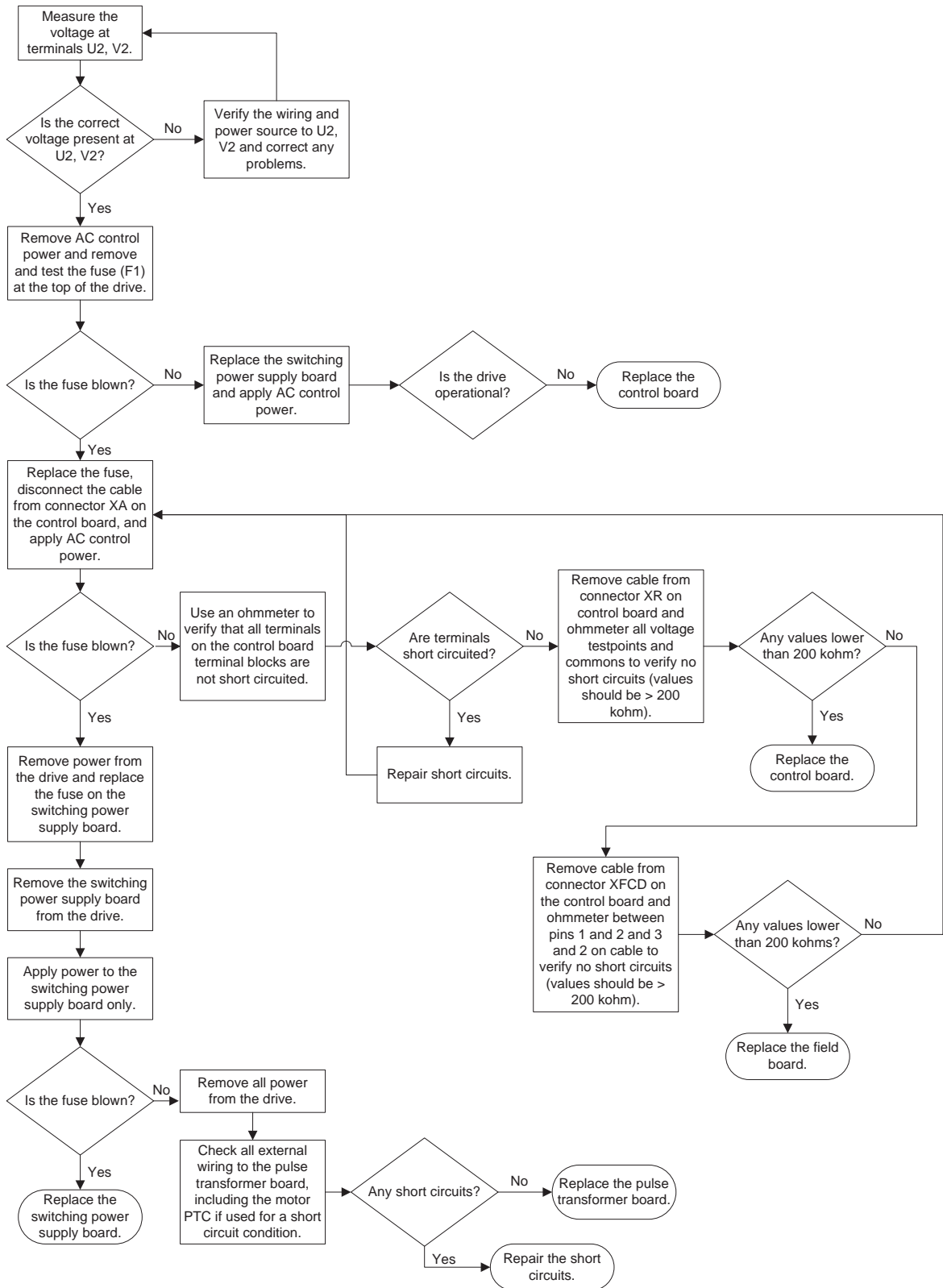

Field Current Loss Failure

The charts below presents the steps in flow chart form for troubleshooting a Field Current Loss fault (F6).

No Field Current Flow Chart

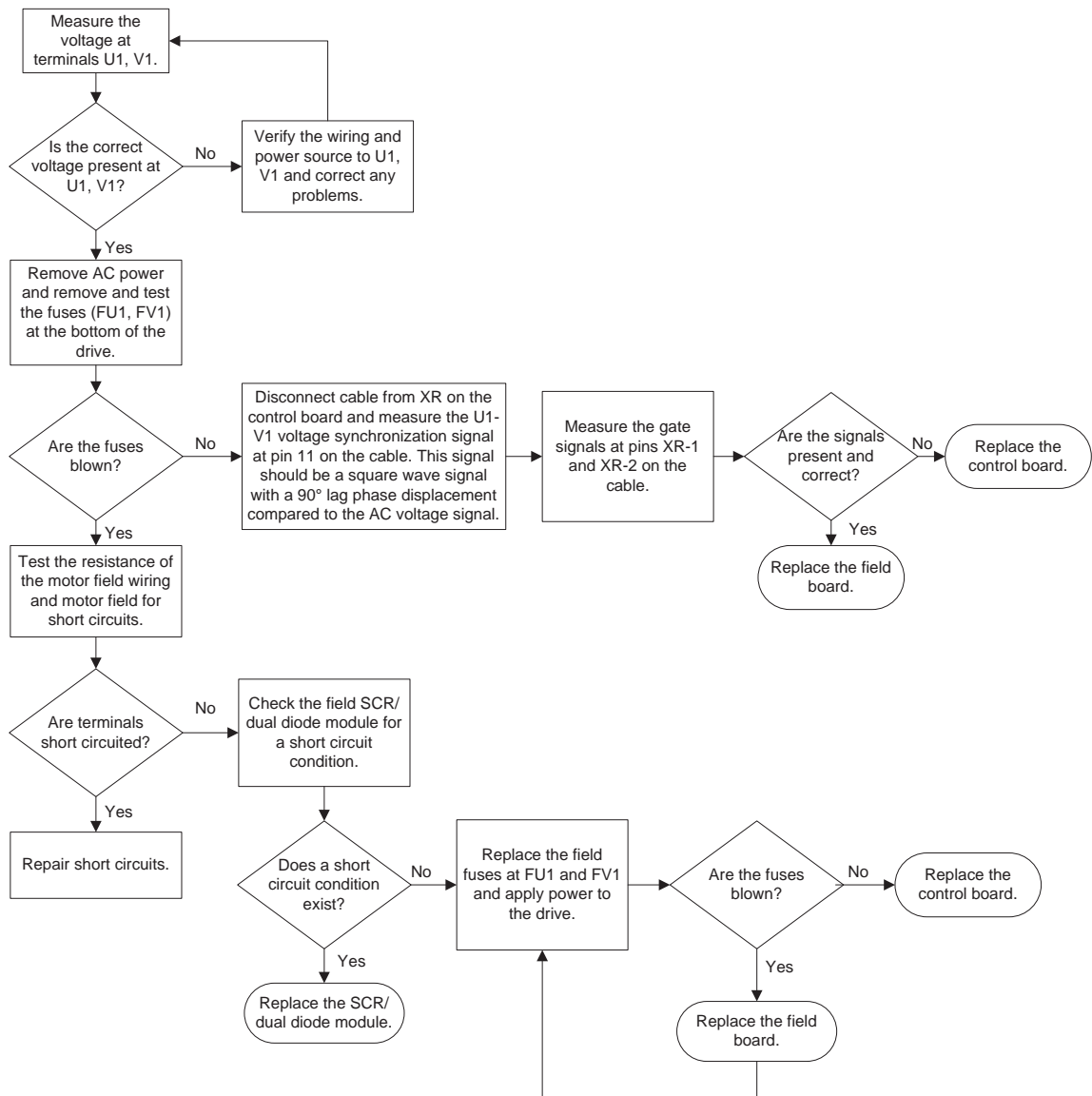

Low or Incorrect Field Current Flow Chart

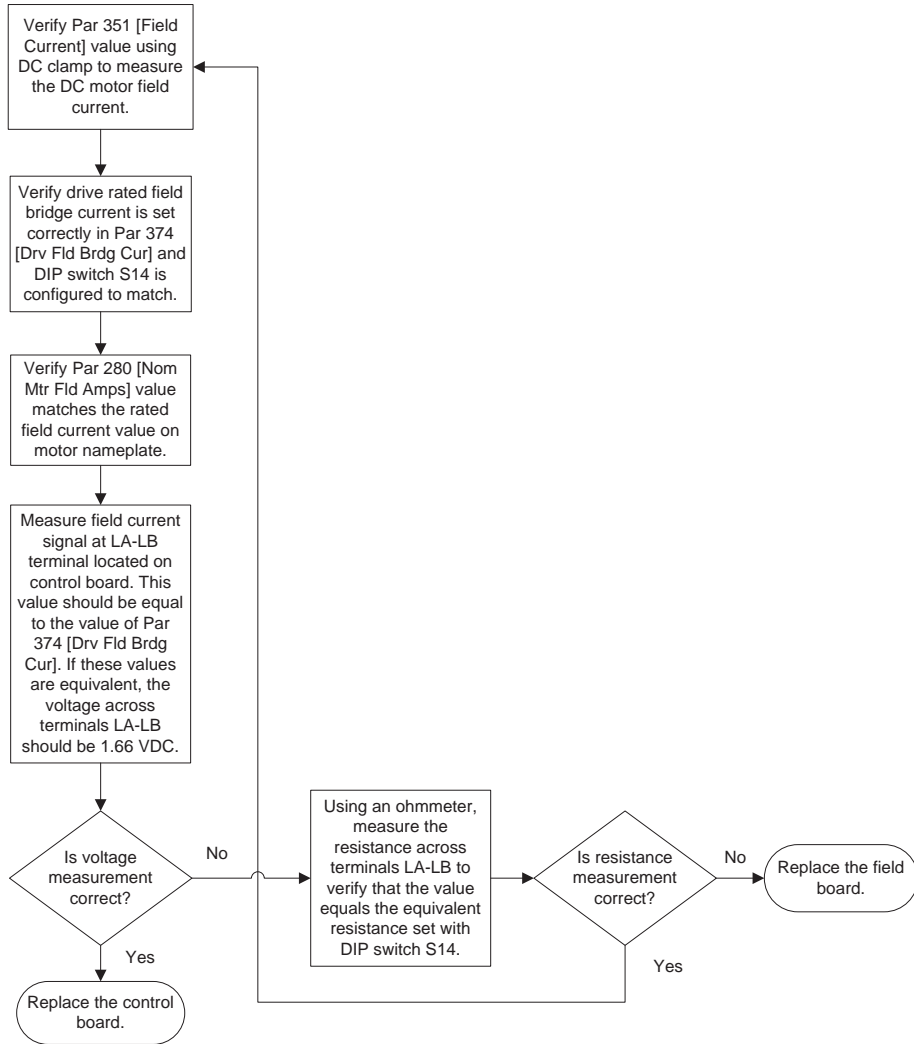

Numerics

115V AC to 24V DC I/O converter board

install 59
remove 58

A

AC current transducers

install 84
remove 79

armature bridge failure

troubleshoot 21

armature SCR modules

test 28

B

bimetal thermostat

install 94
remove 94

C

circuit board

connections 121
layout drawings 121

communication adapter

install 51
remove 49

components

inspection 14

Connected Components Workbench® software

12

contactor fault 38

control board

install 64, 66
remove 59, 64

control power supply

failure 14

cooling fan

install 107
remove 103

D

DC analog tachometer

test 36

DPI/HIM assembly

install 46
remove 45

DriveExecutive™ software 12

E

Electrostatic Discharge Precaution 10

encoder

test 35

F

fault

field current loss 25
heatsink overtemperature 38
main contactor 38
overcurrent 21
power failure 14

fault report

create 38

field board

install 93
remove 88

field circuit fuses

install 45
remove 44

field current loss fault 25

field SCR/dual diode module

install 93
remove 88
test 34

frame size 11

fuse

field circuit 44
switching power supply 44
switching power supply board 44

H

hardware description 10

heatsink overtemperature

fault 38

I

I/O expansion board

install 58
remove 56

inspection

visual 14

install

115V AC to 24V DC I/O converter board 59
AC current transducers 84
bimetal thermostat 94
communication adapter 51
control board 64, 66
cooling fan 107
DPI/HIM assembly 46
field board 93
field circuit fuses 45
field SCR/dual diode module 93
I/O expansion board 58
power traces board 88
protective covers 49
pulse transformer board 73
SCR modules 103
switching power supply board 73
switching power supply fuse 44

L**layout drawings**

- circuit boards 121

M**motor overheating** 38**O****outputs**

- relay 38

overcurrent fault 21**overtemperature**

- heatsink 38

P**parameter configuration**

- save 13

power

- removing 43

power failure fault 14**power traces board**

- install 88
- remove 85

protective covers

- install 49
- remove 47

PTC 38**pulse transformer board**

- install 73
- remove 67
- test 31

R**relay outputs** 38**remove**

- 115V AC to 24V DC I/O converter board 58
- AC current transducers 79
- bimetal thermostat 94
- communication adapter 49
- control board 59, 64
- cooling fan 103
- DPI/HIM assembly 45
- field board 88
- field circuit fuses 44
- field SCR/dual diode module 88
- I/O expansion board 56
- power 43
- power traces board 85
- protective covers 47
- pulse transformer board 67
- SCR modules 95
- switching power supply board 67
- switching power supply board fuse 44

S**safety precautions** 9**save parameter configuration** 13**schematic diagrams** 111**SCR modules**

- install 103
- remove 95

service tools 11**switching power supply board**

- fuse 44
- install 73
- remove 67

T**technical support**

- calling 38

test

- armature SCR modules 28
- DC analog tachometer 36
- encoder 35
- field SCR/dual diode module 34
- pulse transformer board 31

testpoints

- locations 16, 17, 18, 19

thermal switch 38**thermistor** 38**tools**

- service 11

troubleshoot

- armature bridge failure 21
- field current loss 25
- overcurrent fault 21
- power failure fault 14

V**visual inspection** 14

Do you need help?

This drive is available exclusively through **Allen-Bradley distributors** and **Rockwell Automation drive systems**. If there are any questions, please contact your local **Allen-Bradley distributor** or **Rockwell Automation sales office**.

Support is offered by the **Rockwell Automation** TechConnect services, field service teams, product repair services and spare part availability.

Rockwell Automation support

Use these resources to access support information.

Technical Support Center	Find help with how-to videos, FAQs, chat, user forums, Knowledgebase, and product notification updates.	rok.auto/support
Local Technical Support Phone Numbers	Locate the telephone number for your country.	rok.auto/phonesupport
Product Compatibility and Download Center (PCDC)	Download firmware, associated files (such as AOP, EDS, and DTM), and access product release notes.	rok.auto/pcdc
Distributor Partner Locator	Rockwell Automation partners with best-in-class partners worldwide to offer first-rate solutions for your business challenges. Search our Partner-Network database and connect with a partner today.	rockwellautomation.com/en-us/sales/partner-locator

Documentation Feedback

Your comments help us serve your documentation needs better. If you have any suggestions on how to improve our content, contact us at techdoc@weq.net.

Waste Electrical and Electronic Equipment (WEEE)



At the end of life, this equipment should be collected separately from any unsorted municipal waste.

Hardware Service Manual

Series: TPDflex

Revision: 0.1

Date: 10/02/2026

Codice: 1S7TFLEXA

WEG Automation Europe S.r.l.

Via Giosuè Carducci, 24

21040 Gerenzano (VA) · Italy

info.motion@weg.net

Technical Assistance: technohelp@weg.net

Customer Service: salesmotion@weg.net