

**Industrial Motors**

Commercial &  
Appliance Motors

Automation

Digital &  
Systems

Energy

Transmission &  
Distribution

Coatings

# WG01

## WORM GEARS

Up to 730 Nm

TECHNICAL  
CATALOGUE



Driving efficiency and sustainability



# CONTENTS

## General information

1. Technical data

6

2. Nameplate

6

3. Type code

6

4. Range

7

5. Design

8

6. Venting the gear unit

8

7. Overhung and axial loads

8

8. Permissible thermal power loss

8

9. Lubrication

10

10. Painting

10

11. Efficiency rating

10

12. Mounting position

11

## Selection tables

11

13

## Dimension sheets

16

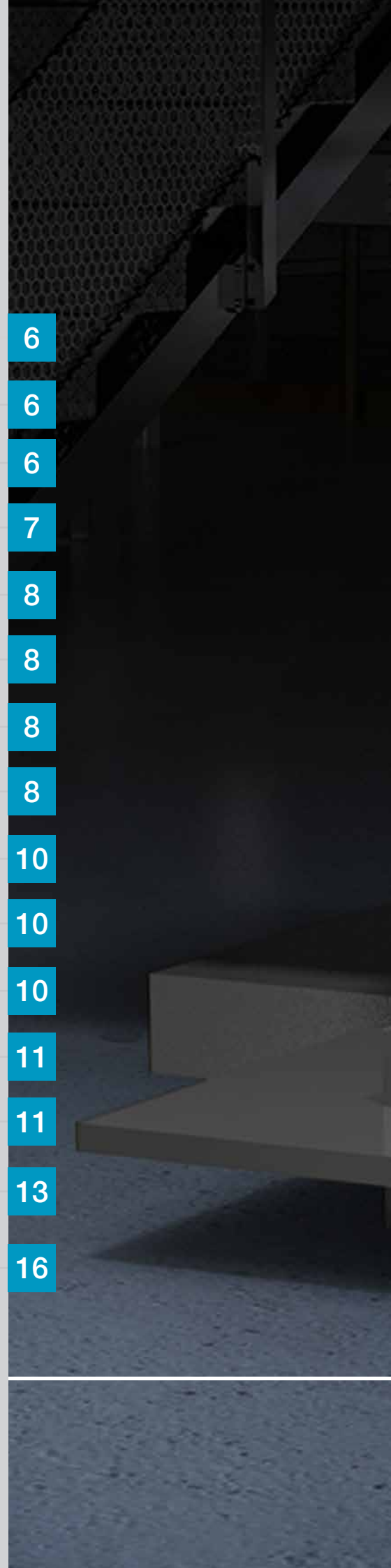



**Immediate availability:**

because of centralised warehousing and the modular concept.



**Modular concept:**

in which the hollow shaft design can be supplemented with an output shaft, flange or torque arm.



**Simple installation:**

thanks to market-compliant mounting dimensions and machined surfaces for positioning in all positions.



**Versatile in use:**

due to the wide ratio range and smart design concept.

# WG01

## Reliability, modern design and modularity

The WG01 single-stage worm gear units provide a high degree of flexibility. Thanks to their compact design and wide ratio range, they can be used in a variety of drive solutions. Available in - for the time being - 7 sizes, the products in the WG01 series are available in different versions with hollow or output shaft, torque arm or flange and are quickly available worldwide.



### Technical data

	Nominal torque [Nm]	Input type	Ratio range	Speed range at 1400 rpm 50 Hz [rpm]	Power range 50Hz [kW]	Output shaft/ Ø hollow shaft [mm]	Output flange Ø [mm]	Housing material
V30	20	B14	7.50 - 60.00	23 - 187	0.12 - 0.18	14 x 30 / 14	80	Aluminium
V40	44	B14	7.50 - 100.00	14 - 187	0.12 - 0.37	18 x 40 / 18	110	
V50	83	B14	7.50 - 100.00	14 - 187	0.12 - 0.75	25 x 50 / 25	125	
V63	164	B5 / B14	5.00 - 100.00	14 - 280	0.25 - 1.5	25 x 50 / 25	180	
V75	233	B5 / B14	7.50 - 100.00	14 - 187	0.55 - 3.0	28 x 60 / 28	200	
V90	415	B5 / B14	7.50 - 100.00	14 - 187	0.55 - 4.0	35 x 80 / 35	210	
V110	727	B5 / B14	7.50 - 100.00	14 - 187	1.1 - 7.5	42 x 80 / 42	280	Cast iron

## Design versions

Hollow shaft

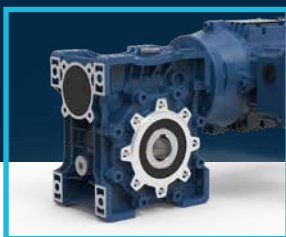

Output shaft

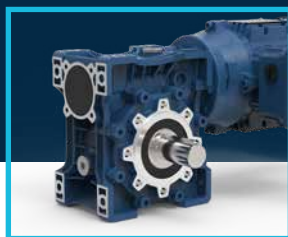

Flange



Torque arm



## Easy motor mounting

A B14 or B5 adapter can be used to mount not only the numerous energy-efficient motors from the WEG portfolio, but also all other IEC standard motors.



## Typical areas of application

Single-stage worm gear units are mainly used where goods or products have to be transported or moved, for example in intralogistics (parcel conveyor belt), in industrial production lines (e.g. food industry), in agriculture (automatic feeding systems), heating technology (screw conveyors) or also in turning devices for aligning the panels of PV systems.

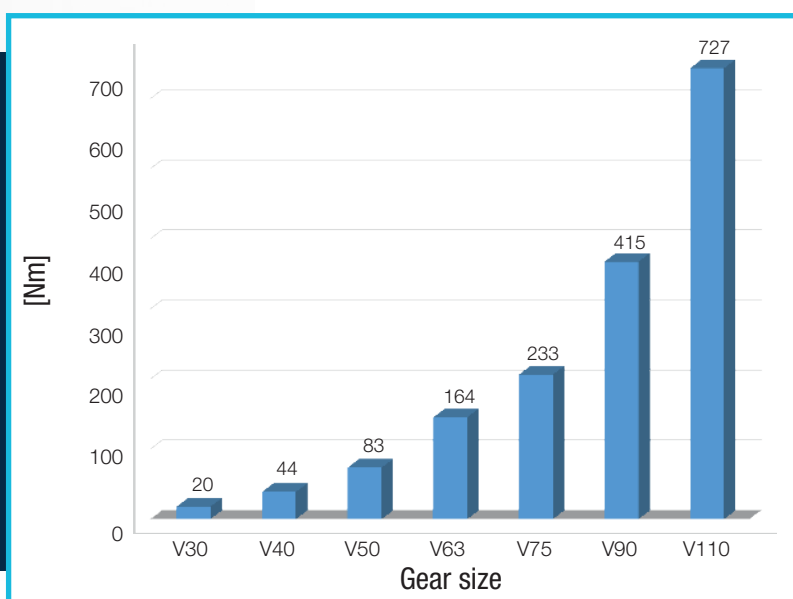

# General information

## 1. Technical data

Size	V30	V40	V50	V63	V75	V90	V110
Power [kW]	0.12 - 0.18	0.12 - 0.37	0.12 - 0.75	0.25 - 1.5	0.55 - 3.0	0.55 - 4.0	1.1 - 7.5
Torque [Nm]	20	44	83	164	233	415	727
Ratio	7.5 - 80.0	7.5 - 100.0	7.5 - 100.0	5.0 - 100.0	7.5 - 100.0	7.5 - 100.0	7.5 - 100.0
Number of stages	1	1	1	1	1	1	1
Housing material	aluminium						cast iron
Hollow shaft	Type	with key acc. to DIN 6885.1					
	Tolerance	F7					
	Material	Sphäroguss EN-GJS-450-10					
Solid shaft	Type	insert shaft with key as per DIN 6885.1 and centering thread / single and double					
	Tolerance	h6					
	Material	steel C45					
Flanges	Tolerance	pilot H8					
	Material	aluminium					cast iron
Shaft seals	Type	type AS acc. to DIN 3760					
	Material	standard NBR					
Lubricants	Type	standard CLP PG 320					
	Quantity [l]	0.04	0.08	0.15	0.30	0.58	1.02

## 2. Nameplate

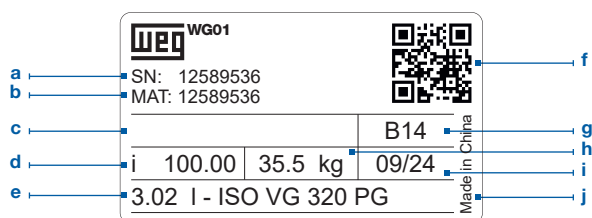

a	Serial number	f	QR code with online link to additional product information
b	Material number	g	Motor input
c	Type code	h	Weight
d	Gear ratio	i	Production date
e	Quantity and type of lubricant	j	Country of origin

### 3. Type code

WG01 V75 1 HH C 80 0.55kW 4P W21 S

1  
 2 3  
4  
5 6 7 8  
9  
10  
11  
12

WG01 V75 1 HH I 80 S

1  
2 3  
4  
5 6 7 8  
12

- 1 Gear line: WG01
- 2 Type of gear: V = Worm gear
- 3 Gear size: 30 40 50 60 75 90 110
- 4 Number of stages: 1 = 1 gear stage
- 5 Mounting: F = B5 flange execution  
H = Mounting on the housing  
T = Torque arm
- 6 Shaft: B = Output shaft on both sides  
H = Hollow shaft  
S = Output shaft
- 7 Input types: C = Adapter for IEC motor B14A  
I = Adapter for IEC motor B5
- 8 Size of motor/adapter: 63 71 80 90 100 112 132
- 9 Motor power: 0.12 - 7.5
- 10 Number of poles: 4P = 4 poles
- 11 Motor line: W21
- 12 Special selection

#### 4. Range

Size	V30	V40	V50	V63	V75	V90	V110
Housing material	aluminium						cast iron

#### 5. Design

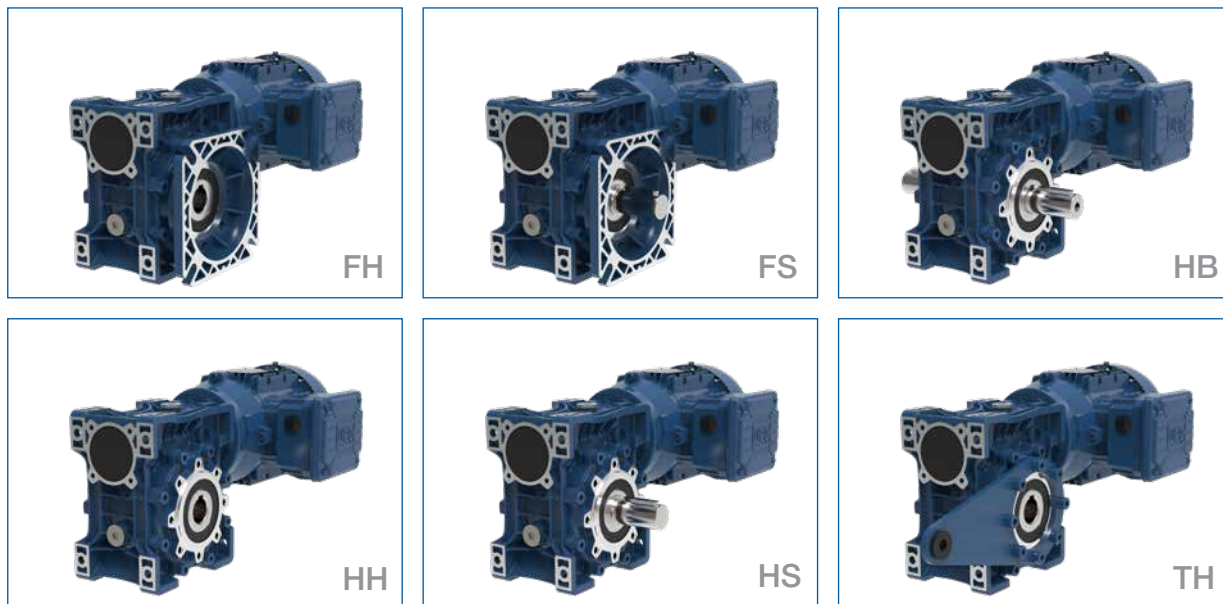

<b>FH</b>	Flange with hollow shaft	<b>HH</b>	Hollow shaft
<b>FS</b>	Flange with output shaft (plug-in shaft)	<b>HS</b>	Output shaft (plug-in shaft)
<b>HB</b>	Output shaft on both sides (plug-in shaft)	<b>TH</b>	Hollow shaft with torque arm

#### 6. Venting the gear unit

WG01 worm gear units of all sizes are not equipped with venting screws. They are supplied with lifetime-lubrication.

#### 7. Overhung and axial loads

The overhung loads ( $F_{rN}$ ) indicated in the respective selection tables apply to gear units with the force acting on the shaft center ( $x=l/2$ ). The permissible overhung loads listed are based on the least favourable loading direction and calculated for standard shafts and standard bearings.

Other load directions and action can be calculated with equations Q1 to Q3. If transmission elements are placed on the output shaft, an appropriate factor ( $f_z$ ) has to be taken into consideration when determining the overhung load.

Gear wheels	Sprockets		V-belts	Flat belts
$f_z=1.1$ ( $z \leq 17$ )	$f_z=1.2$ ( $z \leq 13$ )	$f_z=1.1$ ( $z > 13$ )	$f_z=1.8$	$f_z=2.5$

Use the following equations Q1 and Q2 to calculate the permissible radial loads on the output shaft. Q3 is to calculate the real existing shaft loads for your application. The results are to be compared by using the equation Q4.

<b>Q1</b>	$F_{zL} = F_{rN} \cdot a_1$
-----------	-----------------------------

<b>Q2</b>	$F_{zW} = F_W \cdot a_2$
-----------	--------------------------

<b>Q3</b>	$F_{Qvorh} = \frac{2 \cdot M_2}{d_0} \cdot f_z$
-----------	---

<b>Q4</b>	$F_{Qvorh} \leq F_{zL}$
	$F_{Qvorh} \leq F_{zW}$

Bezeichnung	Einheit	Erklärung
a1		Load action factor - output shaft bearing from Table 1
a2		Load action factor - output shaft from Table 1
d0	[m]	Effective diameter of the transmission element
M2	[Nm]	Geared motor output torque (from selection tables) or required calculated output torque
FzL	[N]	Permissible overhung load for output shaft bearings
FzW	[N]	Permissible overhung load for output shaft
FrN	[N]	Permissible overhung load from selection tables
FW	[N]	Permissible overhung load - Output shaft x=l/2 from Table 2
FQvorh	[N]	Existing overhung load at gear shaft
fz		Factor for transmission element
Mmax	[Nm]	Highest possible output torque for coupling operation (Table 2)

Always use both equations Q1 and Q2 for your calculations.

		x / l						
		0	0.25	0.5	0.75	1	1.5	2
		a1 → Equation Q1						
		1.39	1.18	1.00	0.85	0.73	0.52	0.38
		a2 → Equation Q2						
		2.00	2.00	1.00	0.55	0.38	0.23	0.17

Table 1: Load action factors a1, a2

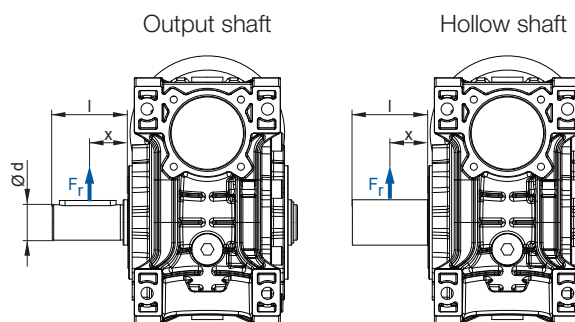

Intermediate values can be interpolated linearly. Combined load ( $F_r \neq 0$ ;  $F_a = 0$ ) on request.

Output shaft [mm]		Mmax at Fr = 0	Output torque M2 [Nm]						
Ø d	l		20	44	83	164	233	415	727
			Fw [kN] at x/l = 0.5 → Equation Q2						
14	30	50	1.5						
18	40	110		2.1					
25	50	300			5.7	5.2			
28	60	410					5.3		
35	80	800						8.7	
42	80	1360							14.1

Table 2: Permissible overhung load - output shaft x = l/2

The axial loads ( $F_{aN}$ ) for the respective execution (output shaft or hollow shaft), given in the selection tables (page 13), are valid at radial force  $F_{rN} = 0$ . If there are axial loads or radial and axial components acting on the drive which are extraordinarily high, we recommend to contact the manufacturer.

## 8. Permissible thermal power loss

The thermal power limit  $P_t$  must always be taken into account when designing a drive. It represents the maximum input power which can be transmitted by the gear unit at the given ambient temperature in a continuous operation mode (S1).

The technical data of the geared motors shown in the selection tables apply to an ambient temperature of +20 °C. Thermal power limits for other temperatures can be seen in the table below.

Parameters to be considered:

- Higher / lower temperatures
- Vertical mounting positions (M2 or M4)
- Higher speed (> 1800 min<sup>-1</sup>) due to e.g. use of frequency inverter
- Small ratios
- Little mounting space

The thermal power limit is calculated from the permissible thermal power loss using the following formula:

$$P_t = \frac{P_v}{1 - \frac{\eta}{100}}$$

Designation	Unit	Description
$P_t$	[kW]	Thermal power limit
$P_v$	[kW]	Permissible thermal power loss (see table)
$\eta$	[%]	Efficiency of the gear unit (see from page 13)

Gear unit size	Ambient temperature								
	-20 °C	-10 °C	0 °C	+10 °C	+20 °C	+30 °C	+40 °C	+50 °C	+60 °C
V30	0.12	0.11	0.09	0.08	0.07	0.06	0.05	0.04	0.02
V40	0.20	0.18	0.16	0.14	0.12	0.10	0.08	0.06	0.04
V50	0.30	0.27	0.24	0.21	0.18	0.15	0.12	0.09	0.06
V63	0.45	0.41	0.36	0.32	0.27	0.23	0.18	0.14	0.09
V75	0.85	0.77	0.68	0.60	0.51	0.43	0.34	0.26	0.17
V90	1.22	1.10	0.97	0.85	0.73	0.61	0.49	0.37	0.24
V110	1.83	1.65	1.47	1.28	1.10	0.92	0.73	0.55	0.37

Permissible thermal power loss  $P_v$

## 9. Lubrication

For WG01 gear units, synthetic oil of viscosity ISO VG 320 PG is used as standard.

Oil quantity *							
Size	V30	V40	V50	V63	V75	V90	V110
Quantity [l]	0.04	0.08	0.15	0.30	0.58	1.02	3.02

\* regardless of the mounting position

## 10. Painting

Standard colour of the gear unit: RAL 5009

Painting system	Application	Layering	NDFT Nominal dry film thickness	Temperature range	Corrosion category DIN EN ISO 12944-5
LC1 (Standard)	Indoor installation, neutral atmosphere	Dip primer Varnish (1K-AY-PUR)	40 µm	-40 °C - +120 °C	C1

## 11. Efficiency rating

Our helical worm gear units achieve efficiency ratings of up to 90 %.

With new gear units, the worm gear set has to run in, the friction is initially higher than after running in. The efficiency before running-in is therefore lower than it will be afterwards. This effect increases with smaller lead angles, i.e. with larger gear reductions. The calculated efficiency rating given in the catalogue can therefore only serve as a guide value. If efficiency and selflocking are particularly crucial to the function of your application, the manufacturer should be consulted, stating all relevant operational constraints.

A reduction in efficiency during the running-in phase from 3 % (low ratio = 5 to 10) up to 12 % (high ratio = 60 to 100) is to be expected.

The gear unit is completely run in after about 24 hours of rated operation. To achieve the values given in the tables (see from page 13) it is important to fulfil the following requirements:

- Gear unit completely run in
- Steady-state temperature reached
- Lubricant in accordance with the stated specifications
- Operation of the gear unit at rated torque

The maximum surface temperature of the housing should not exceed 80 °C.

## 12. Mounting positions

■ Reference area

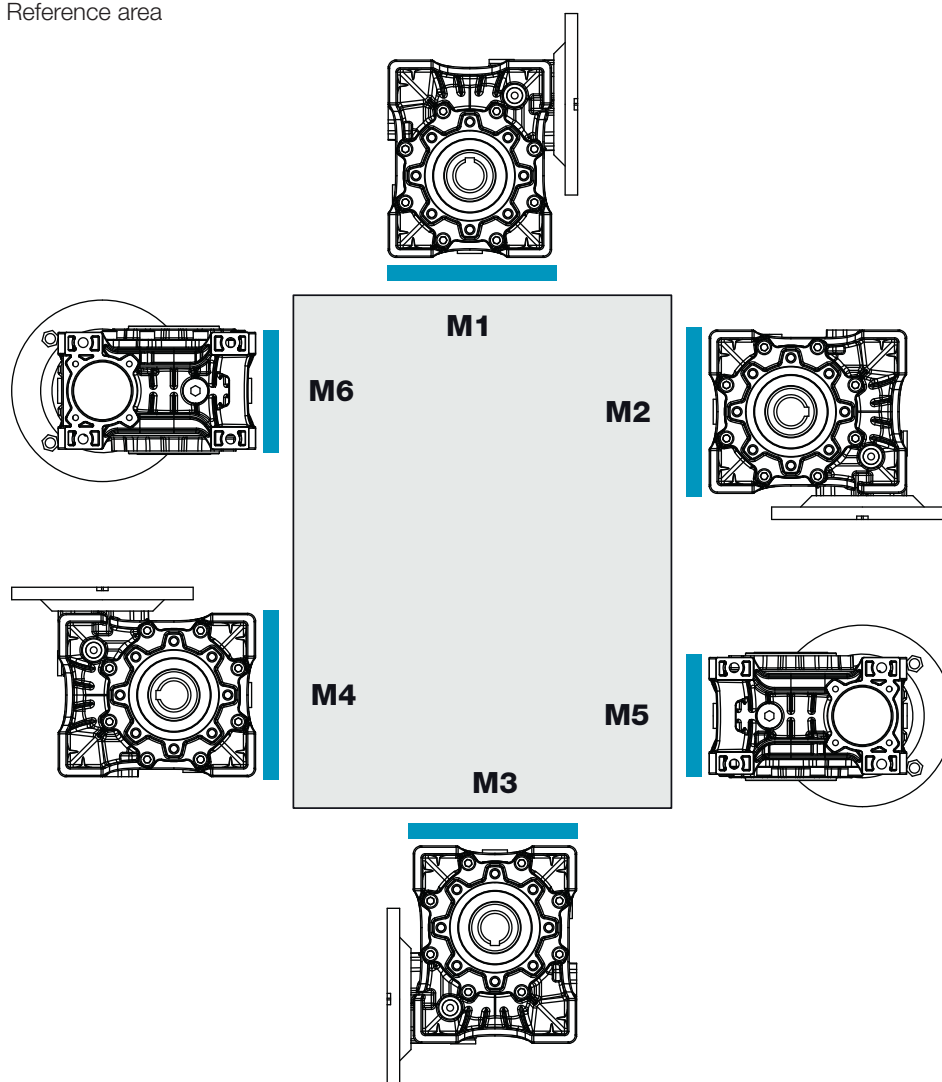

# WEGmotion Drives

From motors, drives and gears to an **integrated motion package.**

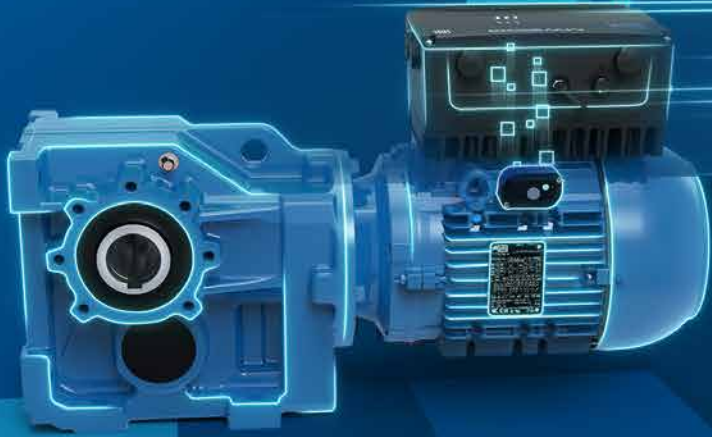

Industry is always on the move. And WEG doesn't stop evolving. Thinking on this, we developed WEGmotion Drives, an integrated and flexible package that combines motors, gear units, drives and digital solutions to improve productivity of your manufacturing plant. Do you know what that means? It means reliability, better control of machines and equipment, more intelligence in operational processes and more efficiency for your industry. It is WEG's partnership getting you ready today for tomorrow's challenge.



**WEGmotion**  
Drives

Driving efficiency and sustainability



# Selection tables - Gear units

## Structure of the selection tables

Type	<b>1</b>	<b>2</b>	<b>3</b>	<b>4</b>	<b>5</b>	<b>6</b>	<b>7</b>	<b>8</b>	<b>9</b>					
	$i_{ges.}$	$M_{2max}$ [Nm]	$n_4$ [min <sup>-1</sup> ]	$\eta_4$	$i_{exakt}$	$n_{1max}$ [min <sup>-1</sup> ]	Weight [kg]	IEC adapter						
								63	71	80	90	100	112	132
<b>V30</b>														
1 stage	<b>10</b>													
$n_1=1400 \text{ min}^{-1}$	<b>11</b>													
Maximum torque 20 Nm	<b>12</b>													

- 1** Type of gear
- 2** Total ratio
- 3** Permissible output torque at Si operation ( $f_B = 1.0$ )
- 4** Output speed (gear unit) at  $n_4 = 1400 \text{ min}^{-1}$
- 5** Efficiency (gear unit) at  $n_4 = 1400 \text{ min}^{-1}$
- 6** Exact mathematical ratio
- 7** Maximum permissible input speed gear unit  
Maximum permissible input speed IEC adapter: I63 - I132 / C63 - C132 =  $3000 \text{ min}^{-1}$   
Higher motor speed on request
- 8** Weight
- 9** Possible IEC adapter sizes B14/B5
- 10** Number of gear stages
- 11** Motor speed  $n_4$  (4 poles)
- 12** Maximum torque

Type	$i_{ges.}$	$M_{2max}$	$n_4$	$\eta_4$	$i_{exakt}$	$n_{1max}$	Weight	IEC adapter							
								[Nm]	[min <sup>-1</sup> ]						
<b>V30</b>	60.00	16	23	49%	60/1	3000	1.2	C							
1 stage $n_1=1400\text{ min}^{-1}$ Maximum torque 20 Nm	50.00	17	28	59%	50/1	3000	1.2	C							
	40.00	18	35	58%	40/1	3000	1.2	C							
	30.00	20	47	64%	30/1	3000	1.2	C							
	25.00	20	56	68%	25/1	3000	1.2	C							
	20.00	18	70	73%	20/1	3000	1.2	C							
	15.00	18	93	77%	15/1	3000	1.2	C							
	10.00	18	140	82%	10/1	3000	1.2	C							
	7.50	18	187	84%	15/2	3000	1.2	C							
<b>V40</b>	100.00	29	14	47%	100/1	3000	2.3	C							
1 stage $n_1=1400\text{ min}^{-1}$ Maximum torque 44 Nm	80.00	33	18	47%	80/1	3000	2.3	C							
	60.00	35	23	57%	60/1	3000	2.3	C							
	50.00	37	28	60%	50/1	3000	2.3	C							
	40.00	41	35	65%	40/1	3000	2.3	C	C						
	30.00	44	47	72%	30/1	3000	2.3	C	C						
	25.00	38	56	74%	25/1	3000	2.3	C	C						
	20.00	39	70	79%	20/1	3000	2.3	C	C						
	15.00	39	93	83%	15/1	3000	2.3	C	C						
	10.00	40	140	85%	10/1	3000	2.3		C						
7.50	40	187	87%	15/2	3000	2.3		C							
<b>V50</b>	100.00	52	14	42%	100/1	3000	3.5	C							
1 stage $n_1=1400\text{ min}^{-1}$ Maximum torque 83 Nm	80.00	64	18	56%	80/1	3000	3.5	C	C						
	60.00	68	23	57%	60/1	3000	3.5	C	C						
	50.00	73	28	63%	50/1	3000	3.5	C	C						
	40.00	77	35	69%	40/1	3000	3.5	C	C						
	30.00	83	47	74%	30/1	3000	3.5	C	C	C					
	25.00	69	56	76%	25/1	3000	3.5	C	C	C					
	20.00	72	70	80%	20/1	3000	3.5		C	C					
	15.00	73	93	84%	15/1	3000	3.5		C	C					
	10.00	70	140	87%	10/1	3000	3.5			C					
	7.50	71	187	88%	15/2	3000	3.5			C					
<b>V63</b>	100.00	118	14	56%	100/1	3000	5.5								
1 stage $n_1=1400\text{ min}^{-1}$ Maximum torque 164 Nm	80.00	119	18	61%	80/1	3000	5.5								
	60.00	130	23	66%	60/1	3000	5.5								
	50.00	133	28	70%	50/1	3000	5.5								
	40.00	143	35	72%	40/1	3000	5.5								
	30.00	164	47	77%	30/1	3000	5.5								
	25.00	131	56	80%	25/1	3000	5.5								
	20.00	131	70	84%	20/1	3000	5.5								
	15.00	134	93	86%	15/1	3000	5.5								
	10.00	129	140	88%	10/1	3000	5.5								
	7.50	126	187	90%	15/2	3000	5.5								
5.00	115	280	91%	5/1	3000	5.5									
<b>V75</b>	100.00	180	14	57%	100/1	3000	8.1								
1 stage $n_1=1400\text{ min}^{-1}$ Maximum torque 233 Nm	80.00	187	18	62%	80/1	3000	8.1								
	60.00	197	23	68%	60/1	3000	8.1								
	50.00	206	28	74%	50/1	3000	8.1								
	40.00	216	35	75%	40/1	3000	8.1								
	30.00	233	47	78%	30/1	3000	8.1								
	25.00	202	56	80%	25/1	3000	8.1								
	20.00	210	70	84%	20/1	3000	8.1								
	15.00	198	93	87%	15/1	3000	8.1								
	10.00	190	140	88%	10/1	3000	8.1								
	7.50	185	187	90%	15/2	3000	8.1								

C = only B14 adapter possible

Type	$i_{ges}$	$M_{2max}$	$n_4$	$\eta_4$	$i_{exakt}$	$n_{1max}$	Weight	IEC adapter							
		[Nm]	[min <sup>-1</sup> ]			[min <sup>-1</sup> ]		[kg]	63	71	80	90	100	112	132
<b>V90</b>	100.00	270	14	60%	100/1	3000	11.8								
1 stage $n_1=1400\text{ min}^{-1}$ Maximum torque 415 Nm	80.00	285	18	65%	80/1	3000	11.8								
	60.00	307	23	71%	60/1	3000	11.8								
	50.00	339	28	75%	50/1	3000	11.8								
	40.00	363	35	77%	40/1	3000	11.8								
	30.00	415	47	80%	30/1	3000	11.8								
	25.00	332	56	84%	25/1	3000	11.8								
	20.00	351	70	86%	20/1	3000	11.8								
	15.00	357	93	87%	15/1	3000	11.8								
	10.00	306	140	90%	10/1	3000	11.8								
7.50	287	187	91%	15/2	3000	11.8									
<b>V110</b>	100.00	473	14	63%	100/1	3000	35.5								
1 stage $n_1=1400\text{ min}^{-1}$ Maximum torque 727 Nm	80.00	512	18	69%	80/1	3000	35.5								
	60.00	620	23	75%	60/1	3000	35.5								
	50.00	656	28	77%	50/1	3000	35.5								
	40.00	693	35	80%	40/1	3000	35.5								
	30.00	727	47	81%	30/1	3000	35.5								
	25.00	665	56	86%	25/1	3000	35.5								
	20.00	649	70	87%	20/1	3000	35.5								
	15.00	660	93	88%	15/1	3000	35.5								
	10.00	588	140	89%	10/1	3000	35.5								
7.50	546	187	90%	15/2	3000	35.5									

# Dimension sheets

## Hollow shaft

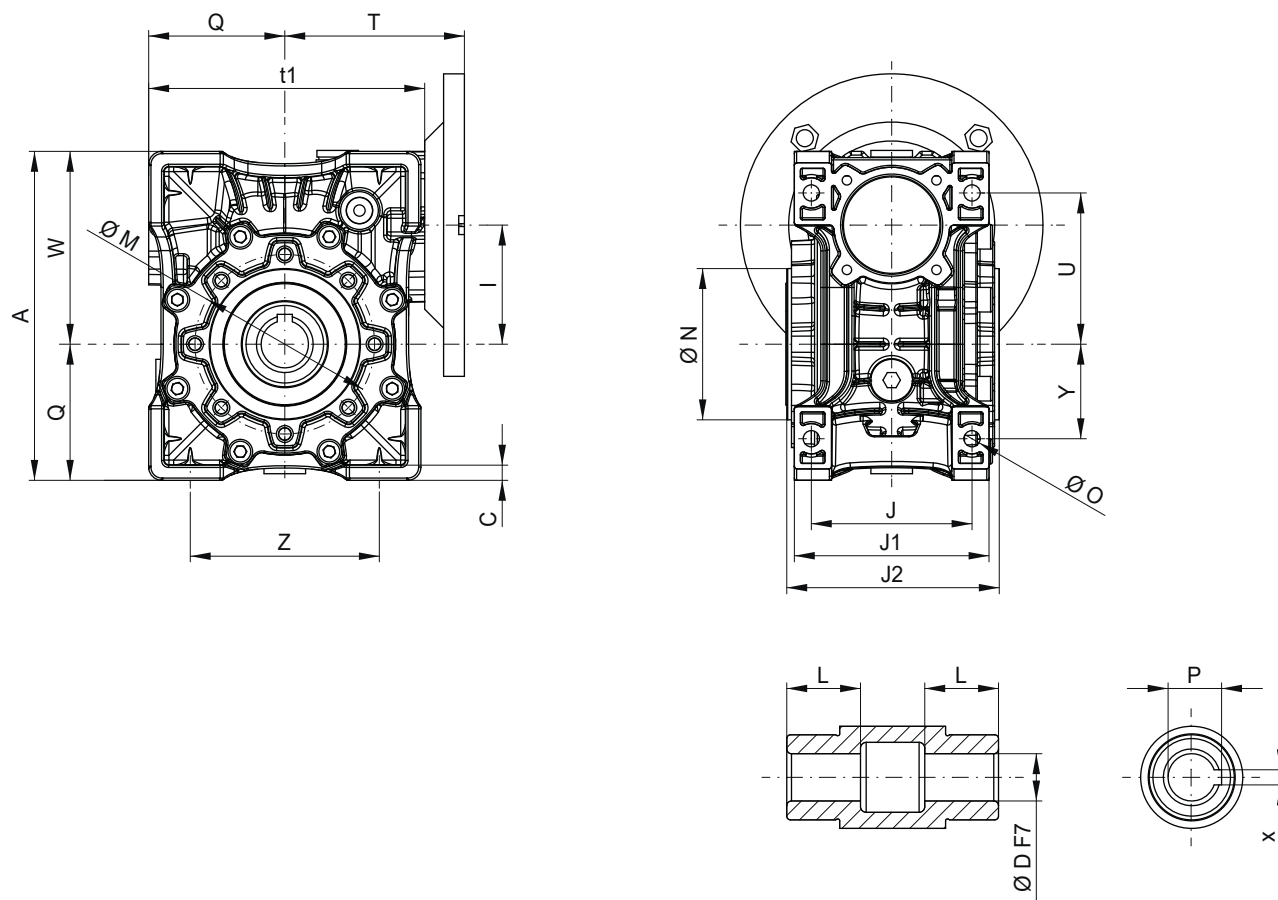

Gear size	A	C	D (F7)	l	J	J1	J2	L	ØM	ØN (H8)
V30	97	5.5	14	30	44	56	63	21	65	55
V40	121.5	6.5	18	40	60	71	78	26	75	60
V50	144	7	25	50	70	85	92	30	85	70
V63	174	8	25	63	85	103	112	36	95	80
V75	205	10	28	75	90	112	120	40	115	95
V90	238	11	35	90	100	130	140	45	130	110
V110	295	14	42	110	115	144	155	50	165	130

Gear size	Ø0	P	Q	T	U	W	Y	Z	t1	x
V30	6.6	16.3	40	55	44	57	27	54	80	5
V40	6.6	20.8	50	70	55.25	71.5	35.5	70	100	6
V50	8.5	28.3	60	80	64	84	40	80	121	8
V63	8.5	28.3	72	95	80	102	50	100	146	8
V75	11	31.3	86	112.5	93	119	60	120	174	8
V90	13	38.3	103	129.5	102	135	70	140	208	10
V110	14	45.3	127.5	160	125	167.5	85	170	252.5	12

All measurements in mm

**Output shaft  
(plug-in shaft pictured with hollow shaft)**

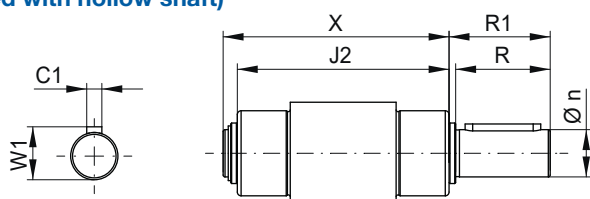

**Output shaft on both sides  
(plug-in shafts pictured with hollow shaft)**

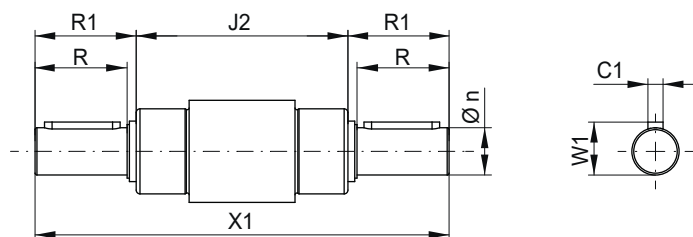

Gear size	C1	J2	R	R1	W1	X	X1	n
V30	5	63	30	32.5	16	102	128	14
V40	6	78	40	43.0	20.5	128	164	18
V50	8	92	50	53.5	28	153	199	25
V63	8	112	50	53.5	28	173	219	25
V75	8	120	60	63.5	31	192	247	28
V90	10	140	80	84.5	38	234	309	35
V110	12	155	80	84.5	45	249	324	42

**Output flange**

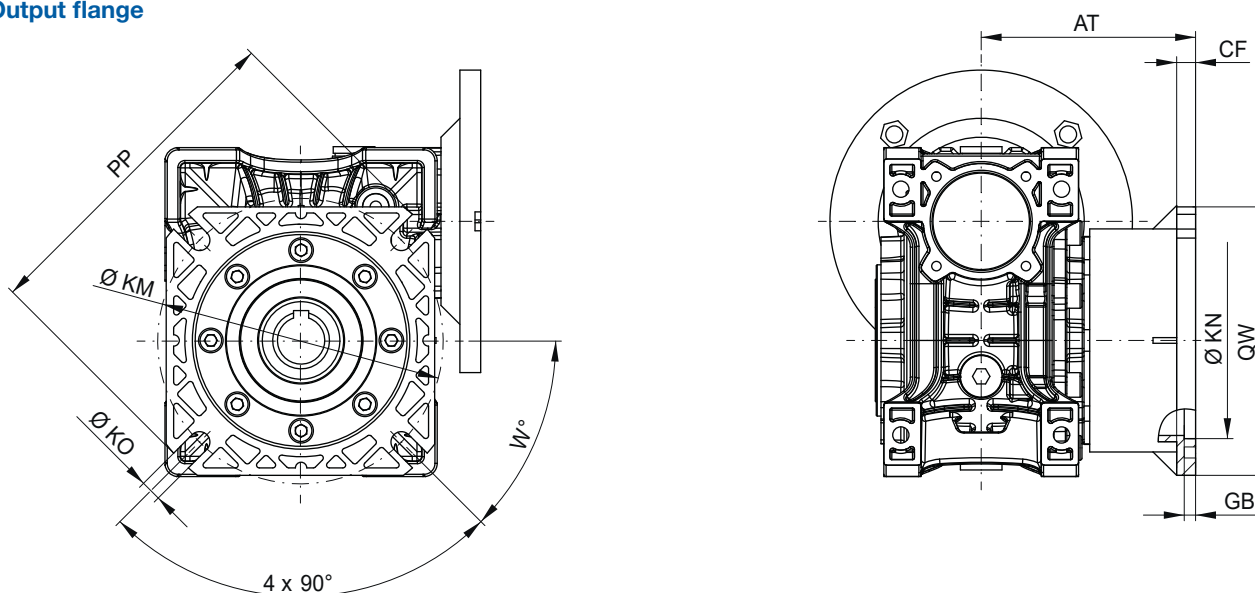

Gear size	AT	CF	GB	KM	KN (H8)	ØKO	PP	QW	W°
V30	54.5	6	4	68	50	6.5	80	70	45°C
V40	67/97*	7.5	4	75	60	9	110	95	45°C
V50	90/120*	9	5	85	70	11	125	110	45°C
V63	82/112*	10	6	150	115	11	180	142	45°C
V75	111	13	6	165	130	14	200	170	45°C
V90	111	13	6	175	152	14	210	200	45°C
V110	131	15	6	230	170	14	280	260	45°C

\* 2 flange sizes available

### Torque arm

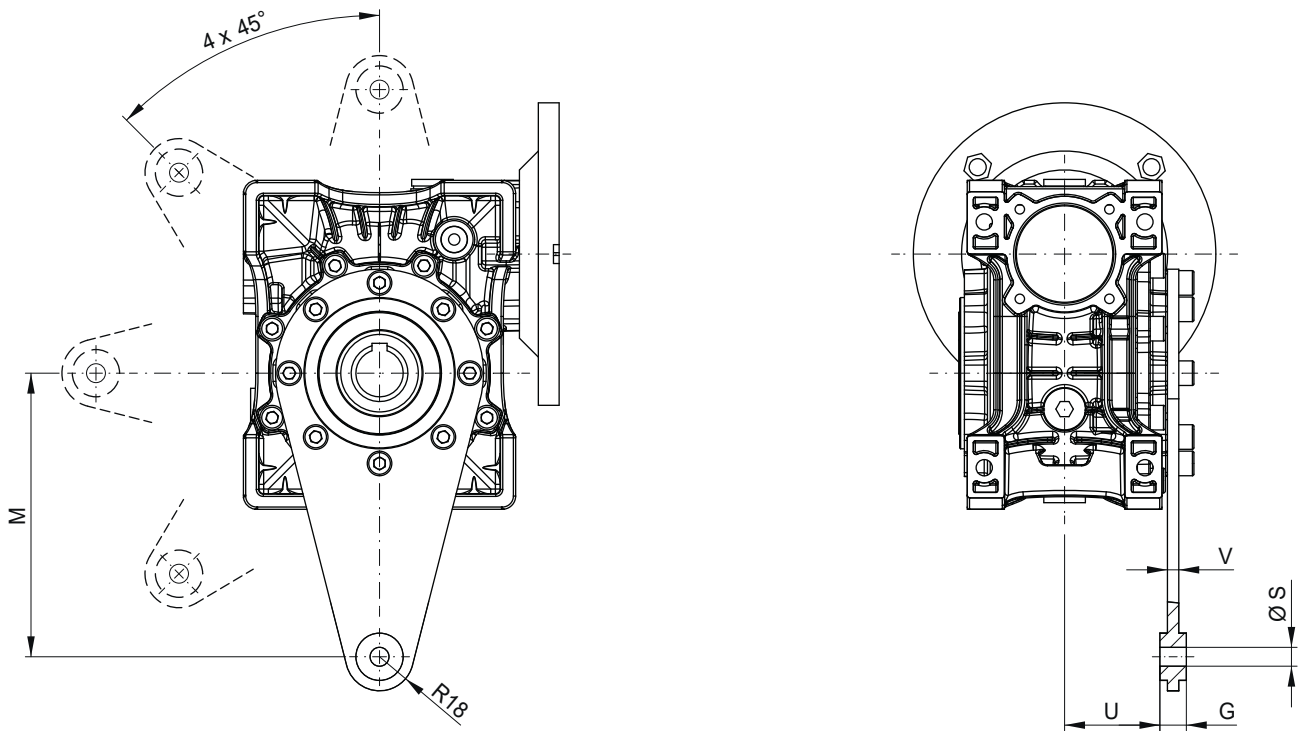

Gear size	G	M	U	S	T	V	W°
V30	14	85	24.0	8	15	4	45°
V40	14	100	31.5	10	18	4	45°
V50	14	100	38.5	10	18	4	45°
V63	14	150	49.0	10	18	6	45°
V75	25	200	47.5	20	30	6	45°
V90	25	200	57.5	20	30	6	45°
V110	30	250	62.0	25	35	6	45°

### Hollow shaft protection cap

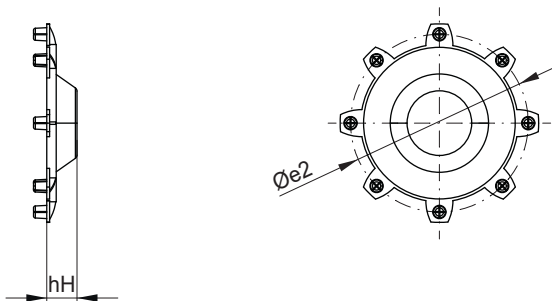

Gear size	hH	e2
V30	14	65
V40	15	75
V50	14	85
V63	16	94
V75	17	115
V90	21	130
V110	18	164

All measurements in mm

### IEC adapter B5

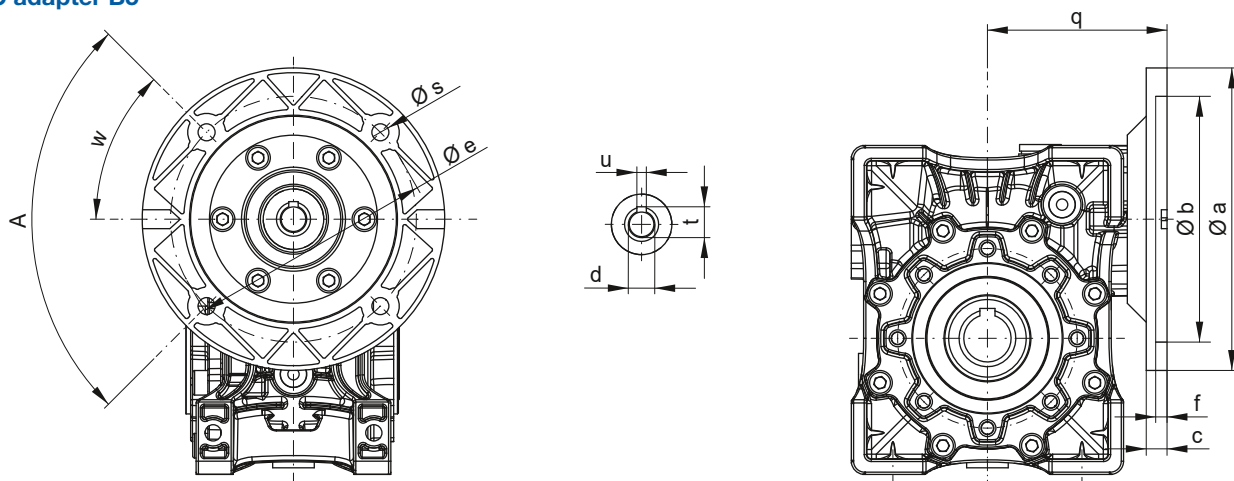

Gear size	Adapter size	A	W	a	b	c	d	e	f	q	s	t	u
V63	I71	90	45	160	110	11	14	130	7	95	9	16.3	5
	I80	90	45	200	130	11.5	19	165	7	95	9	21.8	6
	I90	90	45	200	130	11.5	24	165	7	95	9	27.3	8
V75	I80	90	45	200	130	13.5	19	165	11	112.5	9	21.8	6
	I90	90	45	200	130	13.5	24	165	11	112.5	9	27.3	8
	I100	90	45	250	180	13.5	28	215	11	112.5	9	31.3	8
V90	I80	90	45	200	130	11	19	165	11	129.5	9	21.8	6
	I90	90	45	200	130	11	24	165	11	129.5	9	27.3	8
	I100	90	45	250	180	11	28	215	11	129.5	9	31.3	8
V110	I90	90	45	200	130	11	24	165	11	160	11	27.3	8
	I100	90	45	250	180	12	28	215	11	160	11	31.3	8
	I132	90	45	300	230	15	38	265	11	161	11	41.3	10

### IEC adapter B14A

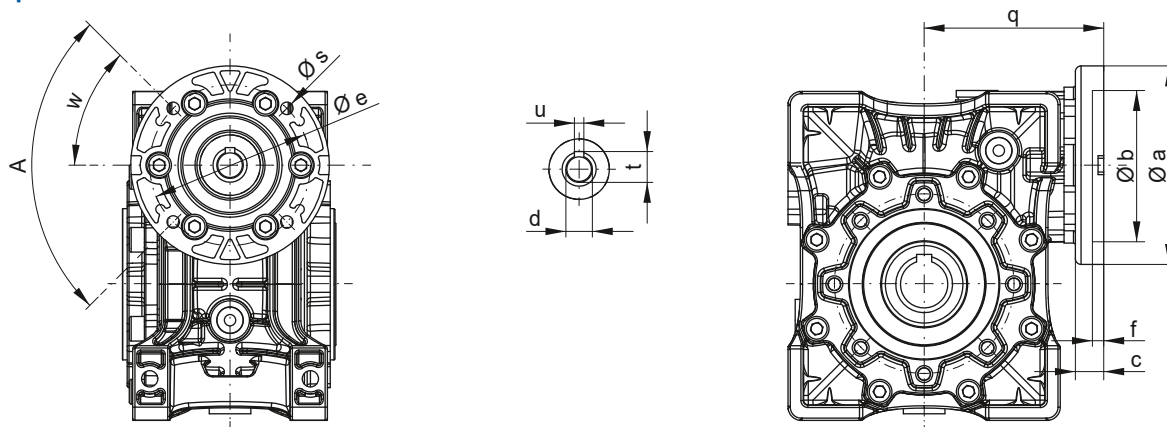

Gear size	Adapter size	A	W	a	b	c	d	e	f	q	s	t	u
V30	C63	90	45	90	60	3	11	75	6	55	5.5	12.8	4
V40	C63	90	45	90	60	6	11	75	8.5	70	6.6	12.8	4
	C71	90	45	105	70	6	14	85	8.5	70	6.6	16.3	5
V50	C63	90	45	90	60	10	11	75	6	80	6.6	12.8	4
	C71	90	45	105	70	10	14	85	6	80	6.6	16.3	5
	C80	90	45	120	80	10	19	100	6	80	6.6	21.8	6
V63	C71	90	45	105	60	15	14	85	7	95	9	16.3	5
	C80	90	45	120	70	10	19	100	7	95	9	21.8	6
	C90	90	45	140	95	10	24	115	7	95	9	27.3	8
V75	C80	90	45	120	80	11	19	100	11	112.5	9	21.8	6
	C90	90	45	140	95	13.5	24	115	11	112.5	9	27.3	8
	C100	90	45	160	110	13.5	28	130	11	112.5	9	31.3	8
V90	C80	90	45	120	80	11	19	100	11	129.5	9	21.8	6
	C90	90	45	140	95	11	24	115	11	129.5	9	27.3	8
	C100	90	45	160	110	11	28	130	11	129.5	9	31.3	8
V110	C90	90	45	140	95	11	24	115	11	149	11	27.3	8
	C100	90	45	160	110	11	28	130	11	160	11	31.3	8
	C132	90	45	200	130	11	38	165	11	160	11	41.3	10

The scope of solutions of the WEG Group is not limited to the products and solutions presented in this brochure.

**Please contact us  
to learn more about our entire portfolio.**

**For our worldwide  
operations visit our website**



**[www.weg.net](http://www.weg.net)**



 +43 (0)2633 404-0

 [info-at@weg.net](mailto:info-at@weg.net)

 WEG Gear Systems GmbH  
Wöllersdorfer Strasse 68 - 2753 Markt Piesting  
Austria