

Helimax Instruction Manual

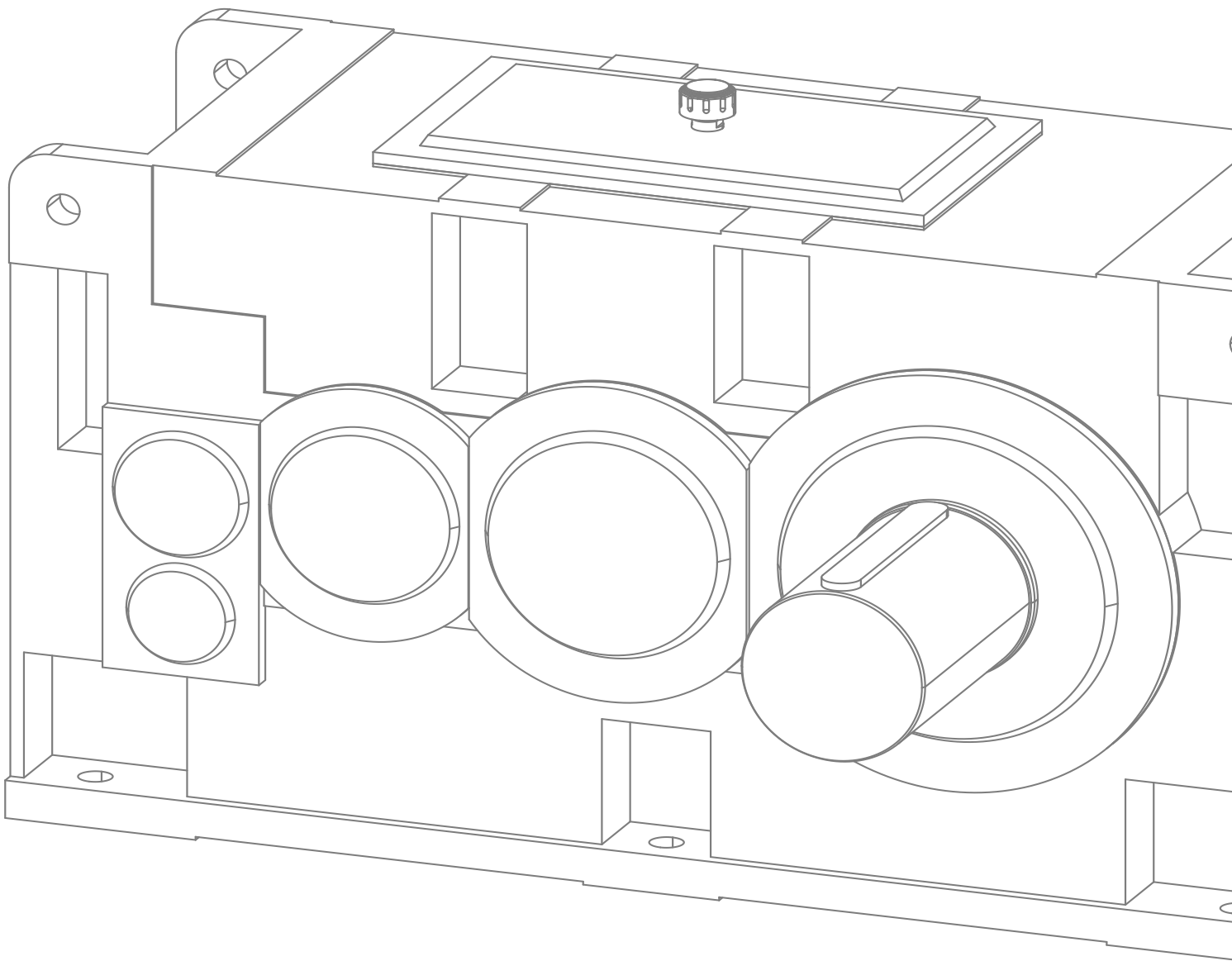

General considerations

This manual provides important directions to be followed during shipment, storage, installation, operation and maintenance of WEG-CESTARI products (gearboxes, gearmotors, parts and pieces). Therefore, we recommend carefully reading the instructions contained in this document. Failure to comply with the instructions informed in this manual and the motor manual (if provided) voids the product warranty and may result in serious personal and material damages.

When a gearmotor is supplied with a WEG motor, the Installation, Operation and Maintenance Manual of the Motor is available on the website: www.weg.net in the section “downloads”. This manual must be carefully observed.

Index

1. Safety instructions and information.....	4
1.1. General information.....	4
1.2. Disclaimer.....	4
1.3. Copyright and protection rights.....	4
1.4. Warranty.....	4
2. General safety.....	6
3. Shipment.....	6
4. Storage.....	7
4.1. Non-operation period.....	7
4.2. Long-Period Storage.....	8
4.3. Operation after Storage:.....	8
4.4. Lubricants.....	9
5. Gearbox Description.....	11
5.1. Gearbox Nameplate.....	11
6. Installation.....	11
7. Operation.....	15
8. Maintenance.....	15
8.1. Disassembly and assembly of gears and bearings.....	17
9. Repairs.....	18
10. Environmental Guidelines.....	18

1. Safety instructions and information



WARNING!

All safety and warning instructions must be followed without exception!

1.1. General information

This documentation is an integral part of the product and must be read carefully before the product is put into operation. The information is intended for all people responsible for mounting, installing, commissioning and maintaining the product and must be strictly followed. We recommend keeping it close to the product.

We take no liability for damage or interruption of operations resulting from failure to comply with this documentation.

In the interest of carrying out future developments, we reserve all rights to make changes and adjustments to this documentation without prior notice.

If you have any questions or would like further information, contact WEG-CESTARI Redutores e Motorreductores S.A.

Intended use:

- Gearboxes and Gearmotors are exclusively intended for generating a defined rotary movement in machines and equipment.
- Any use other than that is considered unintended use.
- The user/operator of the machine or equipment is solely responsible for damages resulting therefrom.
- The details of this manual, the nameplate and other technical documentation must be considered and observed.

1.2. Disclaimer

The directions contained in this Instruction Manual must be followed to ensure the safe and trouble-free operation of the Gearbox or Gearmotor and to achieve the specified product characteristics and performance requirements.

WEG-CESTARI takes no liability for injuries to people, damage to equipment or property resulting from failure to comply with this instruction manual. In such cases, any liability for defects is excluded.

1.3. Copyright and protection rights

All technical documents are protected in accordance with copyright law. Their processing, copy and dissemination, even in parts, as well as other uses are not permitted, except with express written consent.

1.4. Warranty

The warranty against defects in material and workmanship offered by WEG-CESTARI is:

- **Products:** standard period of twelve months from the date the invoice is issued.
- **Services:** standard term of six months from the date the invoice is issued.

Notes:

1) When the warranty period has expired, but still in the month in effect, the service will be done under warranty (e.g.: warranty expiration: 04/01/2017 + service: 04/21/2017 = warranty accepted)

2) If a warranty period is defined differently in the technical and commercial proposal of a particular sale, such period shall override the time limits set out above;

3) The periods above are independent of product installation date and start of operation.

The warranty covers WEG-CESTARI products that present defects resulting from faults of: sizing and specification (when executed by WEG-CESTARI), project, material and manufacturing, provided that the technical analysis performed by WEG-CESTARI shows the existence of defective items falling into these terms and within the warranty period mentioned above.

In case the product presents any abnormal behavior during the product operation, the customer must immediately notify WEG-CESTARI in writing of the defects occurred and make the product available for WEG-CESTARI or its Authorized Repair Shops for the period necessary to identify the cause of the problem and check the warranty coverage. The repair will only be performed after the Nonconformity Report analysis.

WEG-CESTARI reserves the right to test the products returned under warranty in order to confirm the manufacturing defect, as well as to disassemble the products to confirm the real cause of the fault.

In order to be entitled to the warranty, the customer must meet the specifications of WEG-CESTARI's technical documents, especially those set out in the product Installation, Operation and Maintenance Manual. The warranty conditions offered by WEG-CESTARI will always be respected, observing the civil law that governs the business relation.

The warranty will not be granted in the cases below:

- If the customer or end user opens, repairs and/or changes the gearbox or gearmotor without previous consent of WEG-CESTARI;
- Oil leak through the lip seals for drying out caused by coats or paints applied by the end user or machine and equipment supplier;
- Incorrect installation of the equipment (working position different from the required, misalignment, unstable base, shocks or strikes on the shafts etc.), violating the directions contained in the respective Installation, Operation and Maintenance Manual of the product;
- Improper, inefficient or nonexistent lubrication in cases the equipment is supplied without lubricant;
- Lack of preventive maintenance according to the Installation, Operation and Maintenance Manual of the products;
- Incorrect specification or poor sizing of the equipment when performed by the customer;
- Shocks or falls during transportation under the responsibility of the customer or third parties hired by the customer;
- Oil leak caused by blocked breather;
- Oil contamination by external agents (dust, water, etc.) when the gearbox was ordered without air filter;
- Wrong wiring or faults in the power supply in cases of motors;
- Repairs and/or adjustments made by unauthorized or non-qualified people;
- Neglect, recklessness or inability in the installation and operation of the products;
- Natural wear of the product due to use and/or wear of the product due to the action of nature agents (weather, corrosion, etc.);
- Gearboxes/Gearmotors without nameplates;
- Absence or changing of the serial number.

The warranty does not cover expenses resulting from the uninstalling and/or disassembly or installation and/or assembly of the product on the customer's premises.

The warranty does not cover damages caused by equipment manufactured and/or traded by third parties coupled with the products supplied by WEG-CESTARI. It also does not cover defects and/or problems resulting from force majeure or other causes that cannot be attributed to WEG-CESTARI, such as but not limited to: incorrect or incomplete specifications or data supplied by the customer, transportation, storage, handling, installation, operation and maintenance not complying with the provided instructions, accidents, defects in the construction works, use in applications and/or environments for which the product was not designed and/or sized, equipment and/or components not included in the scope of WEG-CESTARI's supply.

The services under warranty may be rendered at the factory of WEG-CESTARI and/or at WEG-CESTARI Authorized Repair Shops. Under no circumstances will the warranty services extend the equipment warranty period. The cases of warranty where it is necessary to change the project to suit the customer's application are an exception to this rule.

WEG-CESTARI's civil liability is limited to the supplied product, and WEG-CESTARI is not liable for indirect or consequential damages, such as loss of profits, sales losses and the like, resulting from the impossibility to use the product while it is damaged and/or under the warranty process.

2. General safety

The customer is responsible for installing the unit in accordance with the good engineering practices. The directions contained in this Instruction Manual must be followed to achieve the characteristics of the drive units and to ensure the approval of warranty claims. Make sure you never put damaged products into operation!

Read this Instruction Manual carefully before beginning any adjustment, installation or maintenance job. Installation, commissioning, maintenance and repair of the gearmotor and electrical accessory equipment may only be conducted by qualified technical personnel, considering the following items:

- Operating Instructions:
- Information labels/tags on the gearmotor
- All other design documents, installation manuals and operation manuals
- Gearmotor specifications and requirements pertaining to the gearmotor
- Applicable regional and national regulations on safety and accident prevention.



WARNING!

Work is only permitted:

- With the drive stopped,
- When disconnected and prevented from being turned on.

Guards around rotating parts must be provided for in the installation project of the equipment to be driven, aiming at protecting people and preventing accidents.

Operation of the drive unit via a frequency inverter can only take place if the specifications shown on the motor nameplate are met.

3. Shipment

Upon delivery, inspect the material to check for possible damage incurred during transportation. In case of damage, immediately notify the shipping company and/or WEG-CESTARI; it may be necessary to avoid putting it into operation.

If necessary, use appropriate transport equipment. Before putting it into operation, remove all fastening devices used during transportation.



ATTENTION!

The lifting lugs are designed for the weight of the gearbox/gearmotor only; no extra load must be added.

For moving gearboxes, use proper ropes, lifting slings and lifting equipment so as not to put people and the equipment itself at risk.

The gearboxes must be moved using the lifting eye bolts/shackles, and in the absence of those, the unit must be lifted through the gearbox housing (Figure 1). When there is a motor, the movement must be in conjunction with the motor eyebolt (respecting the maximum angle of 60° between the cables). (Never lift the equipment using the motor alone).

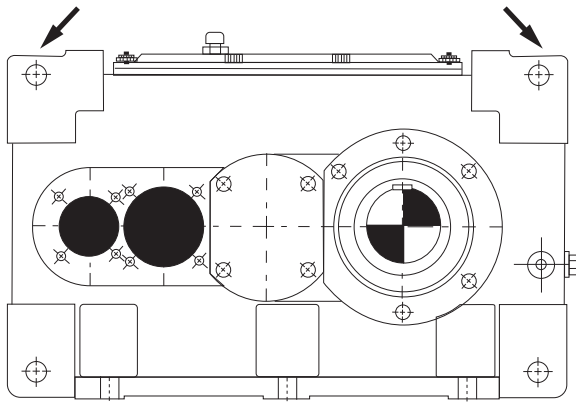

Figure 1 - Gearbox lifting lugs (10 to 14)

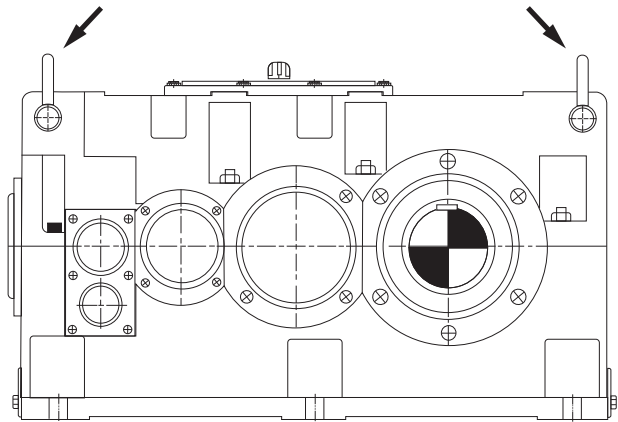

Figure 2 - Gearbox lifting lugs (16 to 65)

Before completely lifting the gearbox/gearmotor, make sure the load is perfectly balanced. The gearboxes/gearmotors must always be handled smoothly in order to avoid impacts and damages to the gearbox/gearmotor, especially to the shaft ends.

4. Storage

WEG-CESTARI products (gearboxes, gearmotors, parts and pieces) must be stored in their original packaging in a closed, dry environment (not directly exposed to sunlight or UV rays), protected against vermin, free from dust, with air humidity below 60%, free from gases, fungi, corrosive agents (contaminated air, ozone, gases, solvents, acids, alkaline, salts, radioactivity etc.) and at ambient temperature between -5 °C to +40 °C.

WEG-CESTARI gearboxes/gearmotors must be stored in the specified and supplied working position, on a flat surface on proper platforms or shelves (not in direct contact with the floor) free of vibration and oscillation.

4.1. Non-operation period

After leaving the factory, WEG-CESTARI gearboxes/gearmotors must be put into operation within six months.

For non-operation periods from six to nine months, it is recommended to fill the entire inside of the gearbox with appropriate lubricants (see item 4.4 Lubricants). Fill the gearbox up to the upper part (right below the breather), thus ensuring all the gears and rolling bearings are immersed in oil. The gearbox input shaft must be rotated at least two complete turns, and this procedure must be repeated at least once every 2 months.



NOTE!

Before operation, the gearbox/gearmotor lubricant must be drained to the appropriate quantity for operation. The appropriate volume of lubricant must be checked in item 4.4 Lubricants.

Protect the lip seals externally with grease; on gearboxes that have taconite seals and will be out of operation for more than six months, apply a thin layer of grease on the outer surface to prevent it from drying out. The grease must be removed before starting operation (recommended grease: NLGI#2EP Texaco Multifak EP2 or similar product); see item 4.4 Lubricants

4.2. Long-Period Storage

Below are the guidelines for cases of storage or shutdown for a long period, that is, more than nine months without operation. These guidelines are recommended for storage for a maximum period of two years. If the relative humidity is below 50%, the WEG-CESTARI product can be stored for up to three years.

Since there may be influences on the gearbox depending on local conditions, the time indications may vary from those mentioned above.

If you need any clarification, please contact WEG-CESTARI.

Preparation for Storage:

- Remove all moisture from the gearbox and from any gearbox cooling system;
- Check the oil level and fill it up if necessary with the lubricant recommended in the product manuals;
- For gearboxes supplied with lubricating oil, add volatile corrosion inhibitor (VCI) to the lubricant corresponding to 2% of the lubricant capacity. Then rotate the shafts several times;
- In the case of gearboxes supplied without oil, mix 10% of the total volume of the lubricant recommended in the manuals with 2% of this total volume of VCI and pour it into the gearbox. VCI additive description MV OIL 1061 (<http://www.vcibrasil.com.br>). Mineral Oil with VCI (Castrol Alpha SP 150 S or Castrol Alpha SP 220 S);
- Seal the gearbox completely by hermetically closing the air holes (breathers) and the area around the dipstick with adhesive tape (if a dipstick is present);
- Put grease around the shafts near the seals and wrap the areas of the shaft close to the lip seals with adhesive tape, touching the lip seals;
- The external fixing surfaces (shafts and flange faces) are protected at the factory; inspect and protect these surfaces if necessary (in case the film has been lost) with an appropriate corrosion inhibitor (Castrol Safecoat DW 801 corrosion inhibitor or similar product with a layer of approximately 50 µm). Any damage caused to the external paintwork during shipment must be corrected;
- If the gearbox is stored outdoors, place it on blocks. Make a structure around it (if possible) and cover it with canvas (cotton tarpaulin). DO NOT use plastic covering. Leave the bottom part open (free) to receive ventilation.

4.3. Operation after Storage:

If the storage or shutdown exceeds two years, or the ambient temperature deviates from the normal range during storage, it is necessary to replace the lubricant in the gearbox before starting operation. Considering that they were properly lubricated, after 2 (two) years, the seals must be replaced.

- Remove all tape used in the preparation for storage;
- Remove any moisture that may have accumulated in the gearbox, clean the gearbox and inspect it to see if there is any damage;
- The VCI corrosion inhibitor is soluble in recommended lubricating oils and does not need to be removed from the gearbox;
- Check this Manual for recommended lubricants and installation, maintenance and operating instructions;

If the gearbox is completely filled with oil, the quantity of oil must be reduced to the recommended amount before starting operation. See the chapter "Mounting positions and lubricant quantities".

If desired, it is possible to supply gearboxes prepared for "long-term storage".

In this case, WEG-CESTARI must be informed during the quotation and acquisition process.

For storage periods longer than nine months, the gearboxes/gearmotors can only start operation if the procedures above are observed.

4.4. Lubricants

Proper lubrication is responsible for the performance and useful life of the gearbox. The gearboxes are lubricated by oil bath and equipped with an oil level sight glass (a dipstick can be used; contact WEG-CESTARI).

The correct oil level is in the center of the sight glass, with the gearbox stopped and in the required working position.

Before starting operation, check that the gearbox is filled with oil and that the lubricant level is as recommended. The recommended lubricant for the industrial line must be extreme pressure mineral oil in accordance with DIN 51517-3 CLP.

The viscosity of the oil depends on the type of gearbox, the angular speed and the ambient temperature. For gearboxes operating at an input shaft speed between 500 rpm and 1800 rpm, and at an ambient temperature between 10 °C and 50 °C, we recommend oil with viscosity:

ISO VG 320 for the 2, 3 and 4-stage HELIMAX and 2 and 3-stage HELICON lines

ISO VG 220 for the 1-stage HELIMAX and HELICON line

For temperatures out of the minimum range of 10 °C to 50 °C, contact WEG-CESTARI.

Table 1 contains some types of recommended oils and their respective manufacturers. For different speeds and temperatures, contact WEG-CESTARI. The approximate quantity of lubricant is indicated in table 2.

Lubricant type		
Manufacturer	Viscosity ISO VG 220	Viscosity ISO VG 320
KLUBER	KluberOil GEM-1-220N	KluberOil GEM-1-320N
SHELL	OMALA S2 G 220	OMALA S2 G 320
KELPEN	TURAN EP 220	TURAN EP 320
TEXACO	MEROPA 220	MEROPA 320
FUCHS	GEARMASTER CLP 220	GEARMASTER CLP 320
MOBIL	MOBILGEAR SP 220	MOBILGEAR SP 320
IPIRANGA	IPIRANGA SP 220	IPIRANGA SP 320
CASTROL	ALPHA SP 220	ALPHA SP 320
PETROBRAS	LUBRAX GEAR 220	LUBRAX GEAR 320

Table 1 - Lubricant type

Approximate volume of lubricant for 1-Stage Helimax (liter)								
Ratio	Size							
	20	23	25	28	32	36	40	46
1.12~2.5	30	41	60	84	118	157	208	271
2.8~4.5	23	33	48	68	93	122	161	206
5.0~5.6	20	29	43	60	82	108	140	176

Table 2 - Approximate volume of lubricant

The operating temperature is the oil temperature after the stabilization of the working temperature at full load (after approximately three hours of continuous operation).

The minimum ambient temperature for the gearboxes to start operating depends on the viscosity and on the type of lubricating oil.

Table 3 contains the minimum ambient temperature for the gearboxes to start operating:

Oil		Minimum Temperature	
Type	Viscosity	Immersion Lubrication	Forced Lubrication
CLP Mineral	ISO VG 220	+2°C	+8°C
	ISO VG 320	+7°C	+14°C
CLP HC Synthetic (PAO)	ISO VG 220	-5°C	+2°C
	ISO VG 320	0°C	+8°C
	ISO VG 460	+6°C	-

Table 3 - Temperature for the gearboxes to start operating

Contact WEG-CESTARI for other temperatures.

The external temperature of the housing is approximately 15 °C lower than the operating temperature (oil temperature).

In the changes, the oil must be drained still warm, because then the oil viscosity is lower, facilitating the flow and cleaning



NOTE!

The lubricant used must be disposed of according to the legislation in force and directions contained in item 10 of this manual.

In case of adverse environmental conditions (high humidity, aggressiveness, dust), the change period may be reduced. In this case, contact WEG-CESTARI.

In the changes, the same oil indicated on the gearbox nameplate and in item 5 of this manual must be used. Do not mix oils from different manufacturers.

The oil change interval is defined according to the operating temperature, as indicated in table 4:

Operating Temperature	CLP Mineral Oil	CLP HC Hydrocarbons synthetic oil	CLP PG Polyglycol synthetic oil
80°C	5.000 hours	15.000 hours	25.000 hours
85°C	3.500 hours	10.000 hours	18.000 hours
90°C	2.500 hours	7.500 hours	13.000 hours
95°C	-	6.000 hours	8.500 hours
100°C	-	3.800 hours	6.000 hours
105°C	-	2.500 hours	4.000 hours
110°C	-	2.000 hours	3.000 hours

Table 4 - The oil change interval



NOTE!

The nameplate (figure 3, page 14 of this manual) indicates the type of oil recommended for the gearbox (CLP=Mineral; CLP HC=Synthetic; CLP PG=Synthetic).

Labyrinth Seal

Labyrinth Seal or **TACONITE** is recommended for environments with a high concentration of suspended dust. It has a grease chamber that prevents the ingress of external contaminants into the gearbox. See Figure 2 for an illustration of this type of seal.

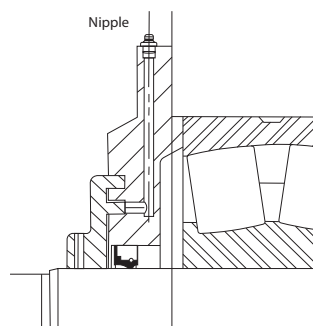

Figure 3 - Labyrinth Seal or TACONITE

The following recommendations must be observed for the labyrinth seal to be effective:

- The standard labyrinth seal is supplied filled with mineral grease NLGI #2EP. It is not necessary to add grease before starting the equipment.
- Table 4 indicates the lubrication period. Table 5 has the recommended grease type. In environments with a high degree of contamination, a shorter lubrication period may be necessary.
- If the gearbox is left out of operation for more than six months, apply a thin layer of grease to the outer surface of the seal to prevent hardening. Before starting the gearbox, check the integrity of the seal and replace it if necessary; remove all old grease and add new grease to the seal.
- The new grease must be added through the nipple, rotating the shaft so that the grease is evenly distributed and until the old grease begins to be expelled through the labyrinth. Clean off excess grease before starting the gearbox.

Shaft speed in rpm	Operating time in hours
to 750	5000
from 750 to 3600	3000

Figure 4 - Lubrication time

Grease	BP	CASTROL	TEXACO	MOBIL	SHELL
Mineral	ENERGREASE LS EP2	TRIBOL 3020/1000-2	MULTIFAK EP2	BEACON EP2	ALVANIA EP2
Food grade	-	-	FM EP2	-	-

Figure 5 - Recommended greases NLGI #2

5. Gearbox Description

5.1. Gearbox Nameplate

Gearboxes are supplied with a nameplate (Figure 3), and gearmotors are supplied with two nameplates, one for the gearbox (Figure 1) and the other for the motor (according to the manufacturer's standard). The nameplates contain symbols and values which determine the gearbox and motor characteristics. They are affixed in an easily visible location.

The data contained on the gearbox nameplate are:

- Name of the manufacturer.
- Serial number and year of manufacturing.
- Gearbox code.
- P, Gearbox rated power (kW).
- fs, Gearbox service factor.
- n1, Gearbox input speed (rpm).
- n2, Gearbox output speed (rpm).
- Speed ratio.
- Oil ISO-VG type and viscosity 40 °C.
- Gearbox weight (kg).

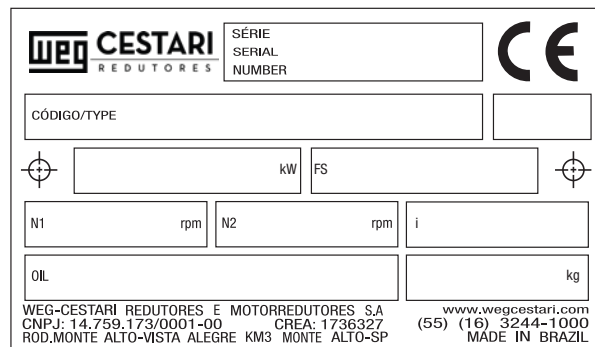

Figure 6 - Nameplate

6. Installation

The shaft ends are protected with a thin layer of anti-corrosive oil; this oil must be removed before installation with regular solvents (varsol, turpentine or the like).



ATTENTION!

The solvent cannot reach the lip seals, and never use sandpaper to remove the varnish. The gearmotors and gearboxes must be installed in the correct working position (as requested in the order), on a flat and rigid base (in order to avoid additional stresses and forces), allowing easy access to the lubrication devices.

When the gearbox is mounted using a torque arm, it must work in traction.

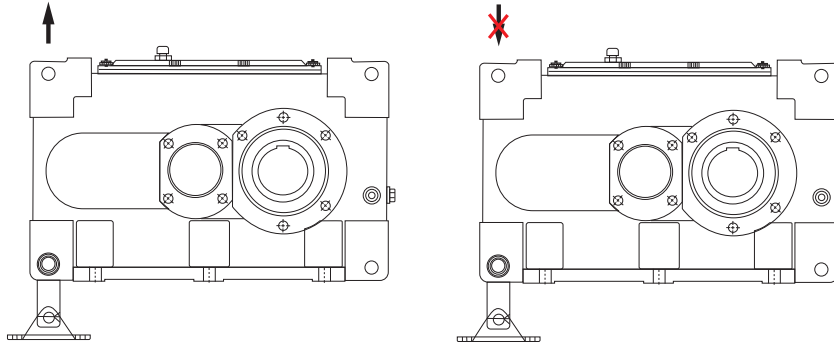

Figure 7 - Mounting the gearbox using a torque arm

For other mounting methods, contact WEG-CESTARI.

The gearbox can be mounted on the machine by means of coupling or transmission elements, such as pulleys, gears etc.

In the direct connection, rigid or elastic coupling may be used; the rigid coupling requires precise alignment between the gearbox and the driven machine; the elastic coupling is recommended to compensate small longitudinal, radial and angular movements of the shafts, in addition to absorbing starting and reversal shocks (check the permissible misalignment in the coupling manufacturer catalog).

When power should be transmitted with speed ratio, it is necessary to use gears or sprockets mounted on the gearbox or gearmotor output shaft. In order to do so, it is necessary to observe the parallelism between the shafts, also checking the minimum diameter allowed (D_{min} , mm) of the transmission element through the following equation:

Where: M_c = Torque to be transmitted (Nm).
 F_r = Radial load permitted on the gearbox output shaft (N)
 K_r = Additional factor.

$$D_{min} = \frac{2000 \cdot M_c}{F_r} \cdot k_r$$

Values for the K_r factor:

- Flat belt with tightener.....2.5
- Flat belt without tightener.....5
- Trapezoidal belt without tightener.....1.75
- Roller chain or silent chain.....1.4
- Gears.....1.15

The elements to be mounted on the shafts, such as couplings, pulleys, sprockets etc., must be drilled with tolerance H7, have weights and sizes compatible with the gearbox and be assembled with slight effort, being as close as possible to the shaft seat, according to the example of Figure 8.

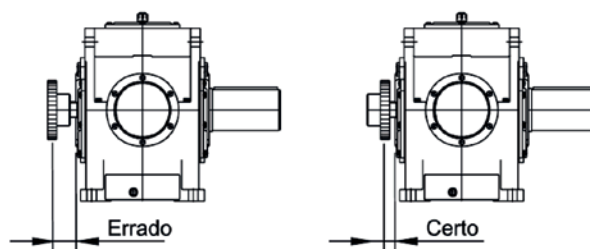

Figure 8 - Shaft coupling assembly.

Using a hammer in the assembly of those elements may damage the rolling bearings and teeth of the gears of the gear unit.

The elements mounted on the shafts must be carefully aligned (even if elastic coupling is used) in order to avoid vibrations and additional stresses. It is convenient to heat the part to be mounted up to about 100°C; the threaded center hole on the gear unit shaft end may be used to help mount the transmission element, which must then be locked so as to prevent axial displacements.



ATTENTION!

In compliance with accident prevention regulations, install guards to protect all rotating parts against unwanted contact and falling objects onto the transmission element, complying at least with the protection requirements (in Brazil according to standard NR12 and/or according to occupational safety standards applicable to the country where the product will be installed and used).

It is unacceptable the mounting by means of strikes, since such a method damages the rolling bearings and gear teeth. When direct coupling is not used between the gear unit and the driven machine, depending on the direction of rotation, the drive must be in such a way that the forces from the transmission element press the gear unit against the mounting base. Observe the appropriate and recommended arrangement.

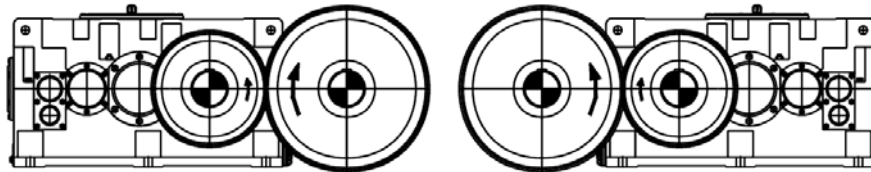

Figure 9 - Recommending the direction of rotation.

In case of gearboxes with hollow shaft, do not mount the gearbox on the equipment with strokes. In order to prevent contact oxidations and difficulties the mounting, it is recommended to spread antioxidant greases (such as Dow Corning Molykote G-Rapid Plus or the like) on the shaft, on the housing and on the key.

If the gearbox is repainted for some reason, the lip seals must be protected to avoid the drying out caused by the paint, which will produce leaks through the seals.

The motor fins and fan must be kept clean and cleared so as to enable proper cooling; the clearance between the air inlet and the wall must be at least 30 mm.

For further information on sizes and tolerances of the input and output shaft ends of the gearmotors and gearboxes, please, refer to WEG-CESTARI technical catalog available on the website: www.wegcestari.com in the “downloads” section.

Industrial gearboxes must be installed on a level base (0.01 mm/100 mm). When the gearbox is specified to work on an inclined surface, do not install it with an inclination angle other than the specification. For standard gearboxes, the installation angle must be within the limits shown.

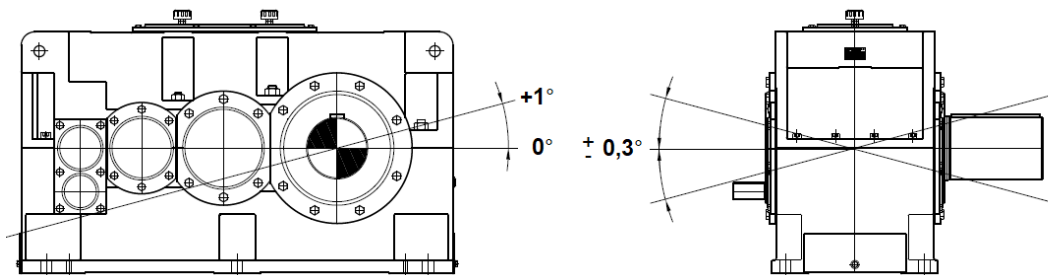

Figure 10 - Installation rotation limit.

The equipment on which the gearbox will be mounted must have the mounting holes in the correct position, observing that all the flange or shoe holes of the gearbox must be used in order to prevent stress concentration.

The screws to be used on the gearbox fixing feet are specified, must have a minimum resistance class of 8.8 and be tightened with the torque indicated in table 5

Sizes	Hole (mm)	Number of holes	Screw	Torque
10	17	6	M16	209
12	20	6	M18	286
14	20	6	M18	286
16	24	6	M22	588
18	24	6	M22	588
20	28	6	M27	1038
23	28	6	M27	1038
25	35	6	M33	1914
28	35	6	M33	1914
32	42	6	M39	3191
36	42	6	M39	3191
40	48	6	M45	4925
46	48	6	M45	4925
50	48	6	M45	4925
54	48	6	M45	4925
58	54	6	M52	7661
65	54	8	M52	7661

Table 5 - Tightening torque

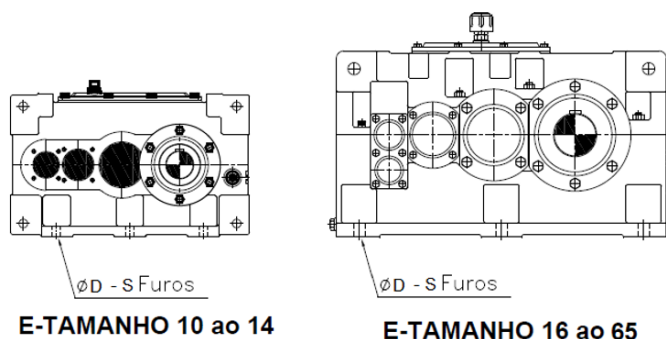

Figure 11 - Positioning the fixing holes

When the gearbox is supplied with a shrink disc, the instructions for the SHRINK DISC assembly are available on the website: www.wegcestari.com in the “downloads” section—they must be read, understood and followed.

The gearbox key is according to DIN 6885 standard (Parallel Keys – DIN 6885 standard, page 1) and the metric thread on the end, according to DIN 332 standard (Center Hole 60° with metric thread – DIN 332 standard, page 2 form D).

Check if the working position and the mounting of the gear unit are correct. Check if all the fastening screws are properly tightened. When the gear units are put into operation, they must run without load for some hours; if no abnormalities occur, the load is gradually applied up to full load.



ATTENTION!

The aforementioned items are only valid for the good operation of the gear unit; the equipment manufacturer is responsible for the specifications for general operation..

7. Operation

Before starting operation, check that the gearbox is filled with oil and that the lubricant level is as recommended (see item 4.4 of this manual).

Check if the gearbox spins freely. Verify if the wiring diagram is according to the indication on the motor nameplate for the desired voltage.

Check if the screws, nuts and connections of the motor terminals and mounting screws and nuts of the gearbox are properly tightened (see item 6 Installation).

Check the desired direction of rotation by starting the gearmotor uncoupled from the equipment; in case you wish to change the direction of rotation, invert any two phases.

When the gearbox starts operating, the oil temperature will rise gradually until stabilizing after approximately three hours, reaching the operating temperature (see item 4.4).

8. Maintenance

The regular preventive maintenance mainly aims at checking the operating conditions of the gearbox. It must be performed by qualified personnel.

There are no rigid rules to be followed regarding inspection programs. The periods or intervals and the types of examinations to be performed may be extended or reduced according to the working conditions and the place where the gear unit is installed.

It is recommended that each gearbox have its own record, such as a card or label. It is important to record all the maintenances, the parts changed and the dates when they were performed. The analysis of those records will allow adjustments in the maintenance program.

Table 6 contains a basic inspection program with the items to be inspected and the suggested intervals; however, such intervals are flexible, and they may be extended or reduced according to the environment conditions where the gearmotor/gearbox is installed.

Table 7 shows the main defects in gearboxes, their causes and corrective actions.

Item to check	Procedures	Frequency
Mechanical conditions	Check for abnormal noise or vibrations, oil leaks, as well as the conditions of the transmission system by examining the lubrication and alignment.	Weekly
Local where the gearmotor is installed	Check for the presence of water or vapors around the gearmotor, excess dust, chips or residue; check the gearbox breather, unclogging it if necessary; check the ventilation conditions of the electric motor.	Weekly
Oil level	Check the oil level and complete it if necessary	Weekly
Gearmotor mounting screws	Check if the vibration did not loosen the gearmotor mounting screws.	Monthly
Terminals and screws	Check if vibration did not loosen the connecting bridges and screws, jeopardizing the contact and the power supply	Monthly
Mechanical conditions	Check the conditions of the transmission elements, replacing them if necessary, and cleaning the gearmotor housing and covers. Check for misalignment or something dragging.	Six-monthly

Table 6 - Maintenance Guide

SYMPTOMS	CAUSES		CORRECTIVE MEASURES
Overheating	Overload	Load exceeds the gearbox capacity	Check the capacity indicated on the gearbox nameplate; replace it with a unit of enough capacity or reduce the load.
	Improper lubrication	Lack of oil. Excess oil in the gearbox causes too much agitation, generating heat and gases inside the housing.	Check the oil level; correct the level.
		Oil out of specification	Drain the oil and refill to the correct level with the oil indicated on the gear unit nameplate or similar product.
Oil loss	Lip seals worn out or defective	Excess oil.	Check the oil level and drain it to the correct level.
		Breather for air ingress and exit of gases clogged.	Clean or replace the breather; use non-flammable solvent for cleaning.
		Insufficient sealing layers between the housing surfaces.	Replace the worn out lip seals with new ones. Apply a new sealing layer, permatex or equivalent product; assemble the unit. Always install the lip seals with grease on the sealing lips.
Excessive noise and vibration	Problems on the mounting screws	Reverse installation	Check the tightening of the screws and if the anchors are firm in the foundation or structure. Check the alignment of the unit and the spacing plates or shims.
	Rolling bearing fault	Fatigue of the rolling bearings; check for wear on the balls, rollers or tracks. Wear may be due to dirt in the oil.	Replace the worn out rolling bearings, clean inside the gearbox and refill with new oil according to the specification.
		Rolling bearing tracks with scales, dents or damaged flanks usually indicate overload.	Replace worn out bearings, check and repair bearing clearances, coupling alignment and loads on the gearbox shafts.
		Fault on the rolling bearing cages also indicate overload.	
	Excessive wear of the gears	Overload causes pitting of the teeth	Check the loads, change the gears or replace it with a gear unit suitable for the load.
	Lack of oil	Oil below the proper level may cause noise.	Check the oil level and correct it.
	Loss of parts	Excessive shocks or incorrect connection with other elements.	Inspect the gear unit for broken parts, loss of screws, nuts or damaged threads. Check the alignment with the driven machine. Check keys and tolerances.
High shaft speed	Driving pulleys or chains too tight.	Check the speeds indicated on the nameplate. Check the tightening.	
Excessive clearance on the shafts	Rolling bearing exposed to abrasive elements cause wear on the balls, rollers and tracks.		Replace the worn out rolling bearings. Clean inside the housing, and refill it with the recommended oil.
Excessive clearance on the gears	Worn out gears and keys or loss of the screws cause backlash (clearance in the gearing); backlash increases as the number of gear sets increases.		Replace worn out gears and keys. Tighten all the screws of the unit.

Table 7 - Gearbox defects

8.1. Disassembly and assembly of gears and bearings

DISASSEMBLY

When disassembling gears and bearings from their respective shafts, it is advisable that this operation be carried out in a hydraulic press.

The surfaces of the shaft where the gears or bearings to be disassembled will move must be covered with a thin layer of oil.

The set must be positioned vertically, on the press table, and the force must be gradually increased until the components are removed from the shaft.

ASSEMBLY

The assembly of gears and bearings must be done hot.

The gears must be heated in an oil bath or oven to approximately 150 °C and assembled on their shafts using a hydraulic press.

Be sure to cover the surface of the shaft with a thin layer of oil.

Take care to ensure that there is perfect alignment when positioning the shaft on the gear, and position the shaft correctly on the press table (aligned and centered) to avoid

damage to the surfaces of the parts during assembly. Pay close attention to the position of the keys.

Bearings must be heated to temperatures that vary according to their size and degree of interference.

The maximum temperature allowed in the bearings is 120 °C; temperatures above may damage the bearing structure.

During assembly, avoid any type of shock to the bearings; always use appropriate devices for this operation.



ATTENTION!

Whenever parts are replaced, such as gears, bearings or shafts, it is necessary to make adjustments to the axial clearances of the bearings. For the HELIMAX line with spherical roller bearings, the axial clearance must be a minimum of 0.3 mm and a maximum of 0.4 mm.

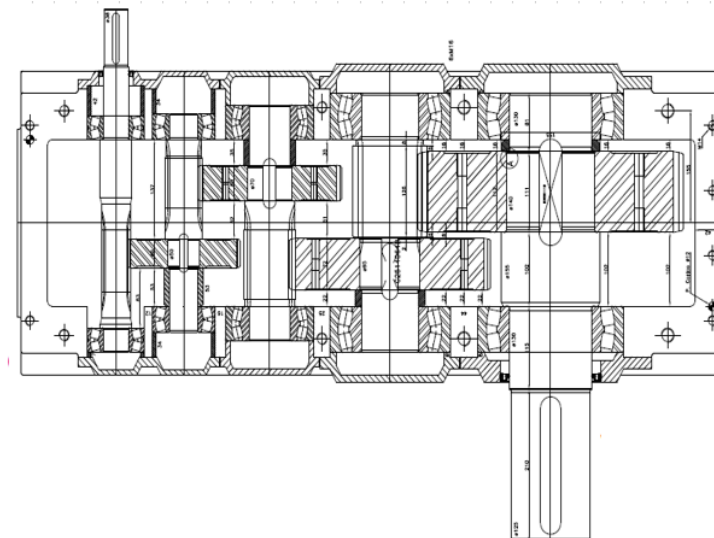

Figure 12 - Bearing play.

9. Repairs

The repairs and occasional disassembly must be performed by qualified personnel. If that is not possible, the gearbox/gearmotor must be sent to an Authorized Repair Shop or to WEG-CESTARI for the service.

The list of Authorized Repair Shops and their contact details are available on the website: www.wegcestari.com in the “Relationship” section, “Sales Channels”. To execute the filter, select “Type”, “Technical Assistance”.

When a part has to be replaced, the customer must contact WEG-CESTARI or an Authorized Repair Shop, providing the serial number indicated on the gear unit/gearmotor nameplate, which will be used to quickly identify the desired part.



ATTENTION!

The replaced parts must be disposed of according to the legislation in force and directions contained in item 10 of this manual.

10. Environmental Guidelines

The products manufactured by WEG-CESTARI meet the legal and environmental requirements defined by the company, and, as part of our Environmental Management System, the information regarding the recycling of our products is available in this Manual:

Housings, Couplings, Covers etc. (Cast Iron, Steel or Aluminum):

They are 100% recyclable and must be sent to foundrie, Shafts, Gears, Pinions, etc.

(Steel):

They are 100% recyclable and must be sent to steel plants.

Bevel Gears (Bronze):

They are 100% recyclable and must be sent to foundries.

Oils:

They must be sent to duly authorized recycling companies.

Seals (Rubber):

They must be sent to companies duly licensed by the state environmental office (landfill class II).

Elastic Elements:

They are 100% recyclable and must be sent to recycling companies.

Packages:

Wood: They are made with reforestation wood and may be reused or used as fuel in boilers when not contaminated (with oil, grease, paint).

Cardboard: They are 100% recyclable when not contaminated (with oil, grease, paint) and must be sent to recycling companies.



NOTE!

If some material is contaminated with oil, grease or paint, it must be sent to companies duly licensed by the state environmental office.



 +55 16 3244 1000

 wegcestari@wegcestari.com

 Monte Alto - São Paulo - Brasil
Bento Gonçalves - Rio Gande do Sul - Brasil

Cód: 50138398 | Rev.: 00 | Date: 02/2024.

*The values indicated are subject to change without notice.
The information contained herein are reference values.*