

CANopen[®]

CFW900-CCAN-W

User's Guide

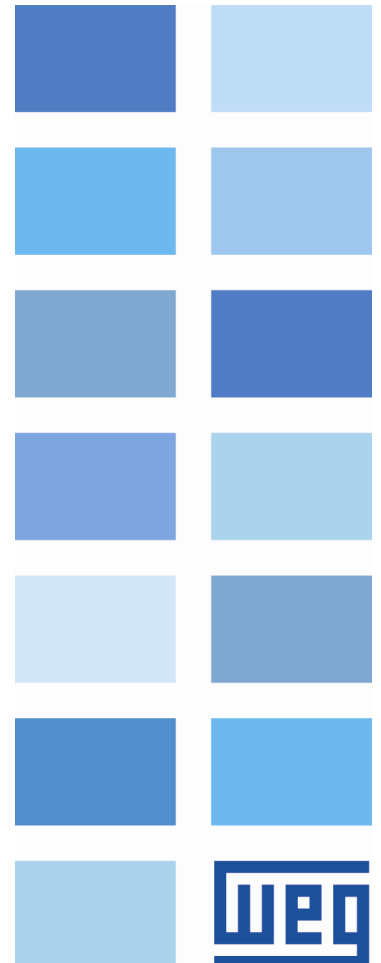



CANopen[®] User's Guide

Series: CFW900

Software version: 1.09.XX

Language: English

Document: 10009145043 / 08

Publication Date: 05/2024

The information below describes the reviews made in this manual.

Version	Revision	Description
V1.02.XX	R00	First edition.
V1.04.XX	R01	General review and parameter list update.
V1.06.XX	R02	General review and parameter list update.
V1.07.XX	R03	General review and parameter list update.
V1.08.XX	R04	General review and parameter list update.
V1.08.XX	R05	General review.
V1.08.XX	R06	General review.
V1.09.XX	R07	General review and parameter list update.
V1.09.XX	R08	General review.

CONTENTS

ABOUT THE MANUAL	6
ABBREVIATIONS AND DEFINITIONS	6
NUMERICAL REPRESENTATION	6
DOCUMENTS	6
IMPORTANT NOTICE	7
TRADEMARKS	7
1 MAIN CHARACTERISTICS	8
2 INTERFACE DESCRIPTION	9
2.1 CANOPEN ACCESSORY	9
2.2 CONNECTOR	9
2.3 POWER SUPPLY	9
3 CANOPEN NETWORK INSTALLATION	10
3.1 BAUD RATE	10
3.2 ADDRESS IN THE CANOPEN NETWORK	10
3.3 TERMINATION RESISTOR	10
3.4 CABLE	10
3.5 CONNECTION TO THE NETWORK	11
4 S STATUS	12
S5 Communications	12
S5.1 Status and Commands	12
S5.7 CAN/CANopen/DNet	14
5 C CONFIGURATIONS	17
C9 COMMUNICATIONS	17
C9.2 I/O Data	17
C9.8 CAN/CANopen/DNet	18
6 OPERATION IN THE CANOPEN NETWORK	20
6.1 ACCESS TO THE DATA	20
6.2 CYCLIC DATA	20
6.3 ACYCLIC DATA	20
6.4 COMMUNICATION OBJECTS - COB	20
6.5 COB-ID	21
6.6 EDS FILE	21
7 OBJECT DICTIONARY	22
7.1 DICTIONARY STRUCTURE	22
7.2 DATA TYPE	22
7.3 COMMUNICATION PROFILE - COMMUNICATION OBJECTS	22
7.4 MANUFACTURER SPECIFIC OBJECTS	23
8 COMMUNICATION OBJECTS DESCRIPTION	25
8.1 IDENTIFICATION OBJECT	25
8.1.1 Object 1000h - Device Type	25
8.1.2 Object 1001h - Error Register	25
8.1.3 Object 1018h - Identity Object	26
8.2 SERVICE DATA OBJECTS - SDOS	26

8.2.1	Object 1200h - SDO Server	26
8.2.2	SDOs Operation	27
8.3	PROCESS DATA OBJECTS - PDOS	28
8.3.1	PDO Mapping Objects	28
8.3.2	Receive PDOs	29
8.3.3	Transmit PDOs	30
8.4	SYNCHRONIZATION OBJECT - SYNC	32
8.5	NETWORK MANAGEMENT - NMT	33
8.5.1	Slave State Control	33
8.5.2	Error Control - Node Guarding	34
8.5.3	Error Control - Heartbeat	36
8.6	INITIALIZATION PROCEDURE	37
9	CIA 402 DRIVE PROFILE	39
9.1	DEVICE CONTROL	39
9.1.1	Object 6040h – Controlword	41
9.1.2	Object 6041h – Statusword	42
9.1.3	Object 6060h – Modes of Operation	42
9.1.4	Object 6061h – Modes of Operation Display	42
9.2	POSITION CONTROL FUNCTION	43
9.2.1	Object 6063h – Position internal actual value	43
9.3	VELOCITY MODE	43
9.3.1	Control and Status Bits	43
9.3.2	Object 6042h – vl target velocity	44
9.3.3	Object 6043h – vl velocity demand	44
9.3.4	Object 6044h – vl control effort	44
9.3.5	Object 6046h – vl velocity min max amount	44
9.3.6	Object 6048h – vl velocity acceleration	44
9.3.7	Object 6049h – vl velocity deceleration	45
10	STARTUP GUIDE	46
10.1	INSTALLING THE ACCESSORY	46
10.2	CONFIGURING THE EQUIPMENT	46
10.3	CONFIGURING THE MASTER	46
10.4	COMMUNICATION STATUS	47
10.5	OPERATION USING PROCESS DATA	47
10.6	ACCESS TO PARAMETERS – ACYCLIC MESSAGES	47
11	FAULTS AND ALARMS	48
12	PARAMETER STRUCTURE	49
13	QUICK REFERENCES	52

ABOUT THE MANUAL

This manual supplies the necessary information for the operation of the CFW900 frequency inverter using the CANopen protocol. This manual must be used together with the CFW900 user's manual and programming manual.

ABBREVIATIONS AND DEFINITIONS

ASCII	American Standard Code for Information Interchange
CAN	Controller Area Network
CiA	CAN in Automation
CIP	Common Industrial Protocol
CRC	Cyclic Redundancy Check
HMI	Human-Machine Interface
ISO	International Organization for Standardization
ODVA	Open DeviceNet Vendor Association
OSI	Open Systems Interconnection
PLC	Programmable Logic Controller
ro	read only
rw	read/write
RTR	Remote Transmission Request

NUMERICAL REPRESENTATION

Decimal numbers are represented by means of digits without suffix. Hexadecimal numbers are represented with the letter 'h' after the number. Binary numbers are represented with the letter 'b' after the number.

DOCUMENTS

The CANopen protocol was developed based on the following specifications and documents:

Document	Version	Source
CAN Specification	2.0	CiA
CiA DS 301 CANopen Application Layer and Communication Profile	4.02	CiA
CiA DRP 303-1 Cabling and Connector Pin Assignment	1.1.1	CiA
CiA DSP 303-3 CANopen Indicator Specification	1.0	CiA
CiA DSP 306 Electronic Data Sheet Specification for CANopen	1.1	CiA
CiA DSP 402 Device Profile Drives and Motion Control	2.0	CiA
Planning and Installation Manual - DeviceNet Cable System	PUB00027R1	ODVA

IMPORTANT NOTICE ABOUT CYBERSECURITY AND COMMUNICATIONS

This product/equipment can connect and exchange information through networks and communication protocols. It has been designed and subjected to tests to ensure correct operation with other automation systems using the protocols mentioned in this manual. Therefore, it is essential that the customer understands the responsibilities in connection with information and cybersecurity when using this equipment.

Consequently, it is the exclusive obligation of the customer to adopt in-depth defense strategies and implement policies and measures to ensure the security of the system as a whole, including with regard to communications sent and received by the equipment. Among such measures, we can point out the installation of firewalls, antivirus and malware protection applications, data encryption, authentication control and physical user access.

WEG and its affiliates take no liability for damages or losses arising from cybersecurity breaches, including, but not limited to, unauthorized access, intrusion, information, or data leak and/or theft, denial-of-service attacks, or any other form of security breach. Using this product under conditions for which it was not specifically designed is not recommended and may result in damage to the product, the network, and the automation system. Thus, it is essential that the customer understand that the external intervention by third-party software applications, such as sniffers or applications with similar actions, has the potential to cause interruptions or restrictions in the functionality of the equipment.

TRADEMARKS

CANopen[®] and CiA[®] are registered trademarks of CAN in Automation. All other trademarks are the property of their respective holders.

1 MAIN CHARACTERISTICS

Below are the main characteristics for communication of the frequency inverter CFW900 with CANopen accessory.

- Network management task (NMT).
- 8 transmission PDOs.
- 8 reception PDOs.
- Heartbeat Consumer.
- Heartbeat Producer.
- Node Guarding.
- SDO Client.
- SYNC producer/consumer.
- It is supplied with an EDS file for the network master configuration.
- Acyclic data available for parameterization.

2 INTERFACE DESCRIPTION

2.1 CANOPEN ACCESSORY

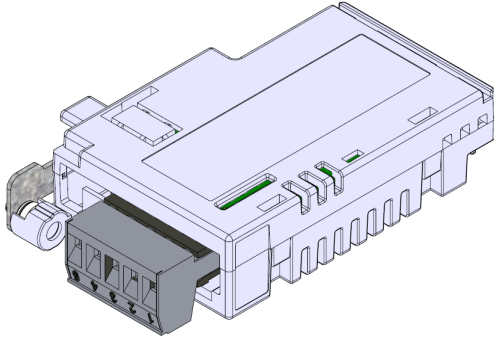

CFW900-CCAN-W:

- Supplied items:
 - Installation guide.
 - CANopen/DeviceNet communication module.

2.2 CONNECTOR

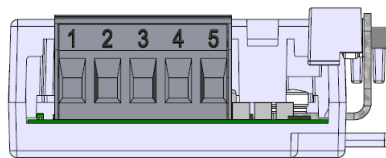

Table 2.1: Pin assignment of connector for CANopen interface

Pin	Name	Function
1	V-	Negative pole of the power supply
2	CAN_L	Communication signal CAN_L
3	Shield	Cable shield
4	CAN_H	Communication signal CAN_H
5	V+	Positive pole of the power supply

2.3 POWER SUPPLY

The power supply of the network must be able to supply enough current to power up the equipments and interfaces connected to the network. The data for individual consumption and input voltage are presented in tables 2.2 and 2.3.

Table 2.2: Power Supply (Vdc)

Minimum	Maximum	Recommended
11 V	30 V	24 V

Table 2.3: Current

Typical	Maximum
30 mA	50 mA

3 CANOPEN NETWORK INSTALLATION

The CANopen network, such as several industrial communication networks, for being many times applied in aggressive environments with high exposure to electromagnetic interference, requires that certain precautions be taken in order to guarantee a low communication error rate during its operation. Recommendations to perform the connection of the product in this network are presented next.



NOTE!

Detailed recommendations on how to perform the installation are available at document "Planning and Installation Manual" (item **DOCUMENTS**).

3.1 BAUD RATE

Equipments with CANopen interface generally allow the configuration of the desired baud rate, ranging from 10 Kbit/s to 1 Mbit/s. The baud rate that can be used by the equipment depends on the length of the cable used in the installation. The table 3.1 shows the baud rates and the maximum cable length that can be used in the installation, according to the protocol recommendation.

Table 3.1: Supported baud rates and cable length

Baud Rate	Cable length
10 Kbit/s	1000 m
20 Kbit/s	1000 m
50 Kbit/s	1000 m
100 Kbit/s	600 m
125 Kbit/s	500 m
250 Kbit/s	250 m
500 Kbit/s	100 m
800 Kbit/s	50 m
1 Mbit/s	25 m

All network equipment must be programmed to use the same communication baud rate.

3.2 ADDRESS IN THE CANOPEN NETWORK

Each CANopen network device must have an address or Node-ID, and may range from 1 to 127. This address must be unique for each equipment.

3.3 TERMINATION RESISTOR

The use of termination resistors at the ends of the bus is essential to avoid line reflection, which can impair the signal and cause communication errors. Termination resistors of 121 Ω | 0.25 W must be connected between the signals CAN_H and CAN_L at the ends of the main bus.

3.4 CABLE

The connection of CAN_L and CAN_H signals must be done with shielded twisted pair cable. The following table shows the recommended characteristics for the cable.

Table 3.2: CANopen cable characteristics

Cable Length (m)	Resistance per Meter (mΩ/m)	Conductor Cross Section (mm ²)
0 ... 40	70	0.25 ... 0.34
40 ... 300	<60	0.34 ... 0.60
300 ... 600	<40	0.50 ... 0.60
600 ... 1000	<26	0.75 ... 0.80

It is necessary to use a twisted pair cable to provide additional 24Vdc power supply to equipments that need this signal. It is recommended to use a certified DeviceNet cable.

3.5 CONNECTION TO THE NETWORK

In order to interconnect the several network nodes, it is recommended to connect the equipment directly to the main line without using derivations. During the cable installation the passage near to power cables must be avoided, because, due to electromagnetic interference, this makes the occurrence of transmission errors possible.

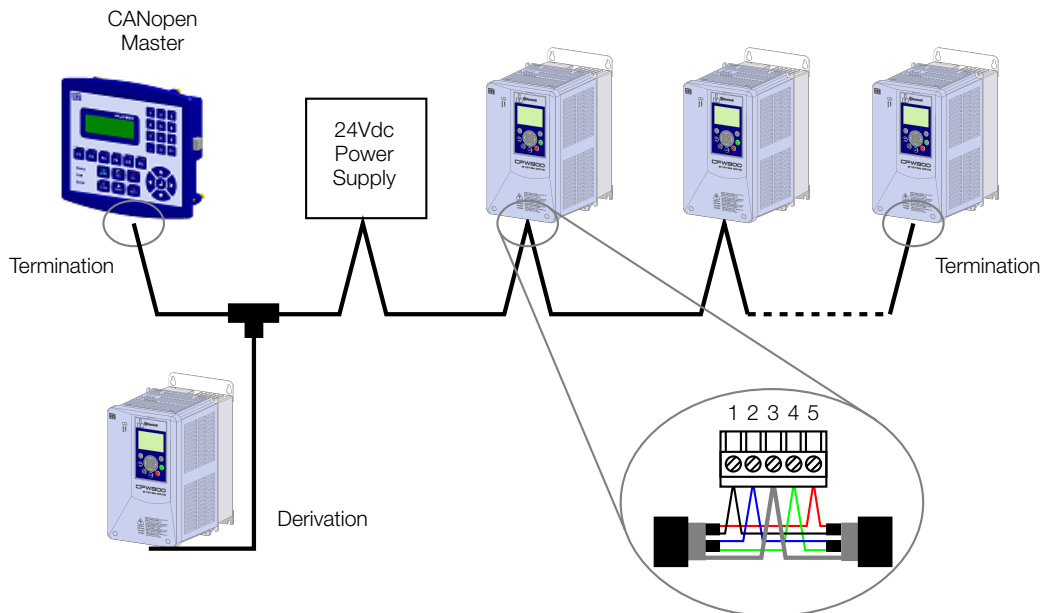
Figure 3.1: CANopen network installation example

In order to avoid problems with current circulation caused by difference of potential among ground connections, it is necessary that all the devices be connected to the same ground point.

To avoid voltage difference problems between the power supplies of the network devices, it is recommended that the network is fed by only one power supply and the signal is provided to all devices through the cable. If it is required more than one power supply, these should be referenced to the same point. Use the power supply to power the bus cable system only.

The maximum number of devices connected to a single segment of the network is limited to 64. Repeaters can be used for connecting a bigger number of devices.

4 S STATUS

This menu contains the status information of the inverter, motor, control accessories and networks. It is also possible to access information related to the functional safety of the inverter. It allows viewing the reading variables of the CFW900.

NOTE!

All parameters present in this menu can only be seen on the HMI display and cannot be changed by the user unless they are linked to the parameters of the **Configurations** menu.

S5 COMMUNICATIONS

It allows viewing the parameters used for monitoring and controlling the CFW900 inverter using communication interfaces.

S5.1 Status and Commands

It allows viewing the CFW900 logical status and commands.

S5.1 Status and Commands

.1 Status Word 1	0 ... 15 Bit
.2 Speed	-200.00 ... 200.00 %
.3 Status Word 2	0 ... 15 Bit
.4 Status Word 3	0 ... 1 Bit

.1 Status Word 1 It indicates the operating status of the inverter. Each bit represents a status.

Bit	Value/Description
Bit 0 STO	0 = No: STO function is inactive (inverter operational). 1 = Yes: STO function is active (inverter locked).
Bit 1 Run Command	0 = No: no run command active. 1 = Yes: run command active.
Bit 2 Local	0 = No: inverter in Remote command mode. 1 = Yes: inverter in Local command mode (via HMI).
Bit 3 Not used	Not used.
Bit 4 No Quick Stop	0 = No: quick stop command active. 1 = Yes: no quick stop command active.
Bit 5 2nd Ramp	0 = No: 1st acceleration and deceleration ramp by C6.1.1 and C6.1.2. 1 = Yes: 2nd acceleration and deceleration ramp by C6.1.4 and C6.1.5.
Bit 6 Config. Mode	0 = No: inverter in normal operation. 1 = Yes: inverter in configuration state. It indicates a special condition in which the inverter cannot be enabled.
Bit 7 Alarm	0 = No: without alarm. 1 = Yes: with alarm active.
Bit 8 Running	0 = No: motor is stopped. 1 = Yes: motor is running according to reference and command.
Bit 9 Enabled	0 = No: inverter is general disabled. 1 = Yes: inverter is general enabled.
Bit 10 Reverse	0 = No: motor running in the forward direction. 1 = Yes: motor running in the reverse direction.
Bit 11 JOG	0 = No: no JOG command active. 1 = Yes: JOG command is active.
Bit 12 Remote 2	0 = No: inverter in Remote 1 command mode. 1 = Yes: inverter in Remote 2 command mode.
Bit 13 Undervoltage	0 = No: without undervoltage. 1 = Yes: with undervoltage.
Bit 14 Not used	Not used.
Bit 15 Fault	0 = No: normal operation. 1 = Yes: fault acting.

.2 Speed It indicates the actual speed of the motor driven by the inverter in percentage of the maximum speed.

- S5.1.2 = 0.00 % ⇒ motor speed = 0 rpm
- S5.1.2 = 100.00 % ⇒ motor speed = C4.3.1.1.2

Intermediate or higher speed values can be obtained by using this scale. For example, if the value read is 25.0 %, considering C4.3.1.1.2 = 1800 rpm, to obtain the value in rpm you must calculate:

100.00 % : 1800 rpm
 25.00 % : Speed

$$\text{Speed} = \frac{25.00 \times 1800}{100.00}$$

Speed = 450 rpm

Negative values indicate motor running in the reverse direction of rotation.

.3 Status Word 2 It indicates other status of the inverter functions. Each bit represents a status.

Bit	Value/Description
Bit 0 Self-tuning	0 = No: inverter is not running the Self-tuning routine. 1 = Yes: inverter is running the Self-Tuning routine to estimate the motor parameters.
Bit 1 Not used	Not used.
Bit 2 Pre-Charge OK	0 = No: pre-charge of the DC link capacitors not completed. 1 = Yes: pre-charge of the DC link capacitors completed.
Bit 3 Not used	Not used.
Bit 4 Not used	Not used.
Bit 5 Decel. Ramp	0 = No: no deceleration. 1 = Yes: inverter decelerating.
Bit 6 Acc. Ramp	0 = No: no acceleration. 1 = Yes: inverter accelerating.
Bit 7 Freeze Ramp	0 = No: ramp operating in normal conditions. 1 = Yes: the path of the ramp is frozen by some command source or internal function.
Bit 8 Setpoint OK	0 = No: motor speed has not reached the reference yet. 1 = Yes: motor speed has reached the reference.
Bit 9 DC Voltage Limitation	0 = No: DC link limitation inactive. 1 = Yes: DC link limitation active.
Bit 10 Current Limitation	0 = No: current limitation inactive. 1 = Yes: current limitation active.
Bit 11 Torque Limitation	0 = No: torque limitation inactive. 1 = Yes: torque limitation active.
Bit 12 Ride-Through	0 = No: Ride-through not running. 1 = Yes: Ride-through running.
Bit 13 Flying Start	0 = No: Flying start not running. 1 = Yes: Flying start running.
Bit 14 DC Braking	0 = No: DC braking inactive. 1 = Yes: DC braking active.
Bit 15 PWM pulses	0 = No: PWM voltage pulses at the output disabled. 1 = Yes: PWM voltage pulses at the output enabled.

.4 Status Word 3 It indicates other status of the inverter functions. Each bit represents a status.

Bit	Value/Description
Bit 0 SD Card	SD card is only detected during the inverter initialization, so the inverter will not detect SD card disconnection during operation. 0 = No: SD card not connected. 1 = Yes: SD card connected.
Bit 1 Not used	Not used.

S5.7 CAN/CANopen/DNet

Status of the CAN communication accessory and the protocols that use this interface.

S5.7 CAN/CANopen/DNet

.1 CAN Controller Status	0 ... 6
.2 Control Word	0 ... 7 Bit
.3 Speed Reference	-200.00 ... 200.00 %
.5 Received Telegrams	0 ... 65535
.6 Transmitted Telegrams	0 ... 65535
.7 Bus Off Counter	0 ... 65535
.8 Lost Messages	0 ... 65535
.9 CANopen Comm. Status	0 ... 5
.10 CANopen Node Status	0 ... 4

.1 CAN Controller Status It allows identifying whether the CAN interface is properly installed, and whether the communication presents errors.

Indication	Description
0 = Inactive	CAN interface inactive. It occurs when the equipment does not have CAN protocol programmed in C9.8.1.
1 = Auto-Baud	Executing the function for automatic detection of the baud rate (only for the DeviceNet protocol).
2 = CAN Active	CAN interface active and without errors.
3 = Warning	The CAN controller reached the warning state.
4 = Error Passive	The CAN controller reached the passive error state.
5 = Bus Off	The CAN controller reached the bus off state.
6 = No Bus Power	The CAN interface has no power supply between pins 1 and 5 of the connector.

.2 Control Word It indicates the status of the control word via CAN interface. This parameter can only be changed via CAN interface. For other sources, only read access is allowed.

For the commands written in this parameter to be executed, the inverter must be programmed to be commanded via CAN/CO/DN. This programming is done through menu C4.

Each bit of this word represents a command that can be executed on the inverter.

Bit	Value/Description
Bit 0 Enable Ramp	0 = No: stops the motor by deceleration ramp. 1 = Yes: the motor turns according to the acceleration ramp until reaching the speed reference value.
Bit 1 General Enable	0 = No: disables the inverter completely, interrupting the motor power supply. 1 = Yes: enables the inverter completely, allowing the operation of the motor.
Bit 2 Run Reverse	0 = No: runs the motor in the direction of the reference signal (forward). 1 = Yes: runs the motor in the opposite direction of the reference signal (reverse).
Bit 3 Enable JOG	0 = No: disables the JOG function. 1 = Yes: enables the JOG function.
Bit 4 R1/R2 Mode	0 = R1: selects the Remote 1 command mode. 1 = R2: selects the Remote 2 command mode.
Bit 5 2nd Ramp	0 = No: 1st ramp acceleration and deceleration according to parameters C6.1.1 and C6.1.2. 1 = Yes: 2nd ramp acceleration and deceleration according to parameters C6.1.4 and C6.1.5.
Bit 6 No Quick Stop	0 = No: enables quick stop. 1 = Yes: disables quick stop.
Bit 7 Fault Reset	0 = No: not used. 1 = Yes: in the transition, if in a fault state, it resets the fault.

.3 Speed Reference It indicates the speed reference sent via CAN interface to the motor driven by the inverter in percentage of the maximum speed. This parameter can only be changed via CAN interface. For other sources, only read access is allowed.

For the reference written in this parameter to be used, the inverter must be programmed to use the speed reference via CAN/CO/DNET. This programming is done through menu C4.

- S5.7.3 = 0.00 % ⇒ speed reference = 0 rpm
- S5.7.3 = 100.00 % ⇒ speed reference = C4.3.1.1.2

Intermediate or higher speed values can be obtained by using this scale. For example, if the desired value for the reference is 900 rpm, considering C4.3.1.1.2 = 1800 rpm, it should be calculated:

100.00 % : 1800 rpm
 Reference % : 900 rpm

$$\text{Reference \%} = \frac{900 \times 100.00}{1800}$$

Reference % = 50 %

Negative values can be used to reverse the direction of rotation of the motor. The direction of rotation of the motor, however, also depends on the value of the rotation direction command bit in S1.6.1:

- Bit Direction of Rotation = 1 and S5.7.3 > 0: reference for the forward direction
- Bit Direction of Rotation = 1 and S5.7.3 < 0: reference for the reverse direction
- Bit Direction of Rotation = 0 and S5.7.3 > 0: reference for the reverse direction
- Bit Direction of Rotation = 0 and S5.7.3 < 0: reference for the forward direction

.5 Received Telegrams This parameter works as a cyclic counter that is incremented every time a CAN telegram is received. It provides feedback to the operator if the device is able to communicate with the network.

.6 Transmitted Telegrams This parameter works as a cyclic counter that is incremented every time a CAN telegram is transmitted. It provides feedback to the operator if the device is able to communicate with the network.

.7 Bus Off Counter Cyclic counter that indicates the number of times the equipment went into the bus off state on the CAN network.

.8 Lost Messages Cyclic counter that indicates the number of messages the CAN interface received but could not be processed by the device. In case the number of lost messages frequently increases, it is recommended to reduce the baud rate used for the CAN network.



NOTE!

These counters are reset to zero whenever the equipment is turned off, reset or reach the maximum limit set in the parameter.

.9 CANopen Comm. Status It indicates the status of the CAN accessory in relation to the CANopen network, informing if the protocol has been enabled and if the error control service is active (Node Guarding or Heartbeat).

Indication	Description
0 = Inactive	CANopen protocol disabled.
1 = Not used	Not used.
2 = Comm. Enabled	Communication enabled.
3 = Error Ctrl. Enab.	Communication enabled and error control enabled (Node Guarding/Heartbeat).
4 = Guarding Error	Node Guarding error occurred.
5 = Heartbeat Error	Heartbeat error occurred.

.10 CANopen Node Status Each slave in the CANopen network has a state machine that controls its behavior in relation to communication. This parameter indicates in which state the device is, according to the protocol specification.

Indication	Description
0 = Inactive	CANopen protocol disabled.
1 = Initialization	Communication with the device is not possible during this step, which is completed automatically.
2 = Stopped	Only the NMT object is available.
3 = Operational	All communication objects are available.
4 = Pre-Operational	It is possible to communicate with the slave, but the PDOs are not available for operation.

5 C CONFIGURATIONS

It allows changing the CFW900 configuration parameters. Depending on the parameter property, it is possible to set its value according to the table below.

Property	Description
Stopped	Parameter can only be changed with the motor stopped.
Model	Default value may change according to inverter model.

NOTE!

Parameter options with the description "Not used" are for WEG's exclusive use.

C9 COMMUNICATIONS

It sets the CFW900 to exchange information via communication network.

C9.2 I/O Data

It sets the cyclic data exchange area of the communication networks.

C9.2.1 Reading Data

It configures a set of 16-bit parameters to be read via communication network.

C9.2.1 Reading Data
C9.2.1.1 Word #1

C9.2.1.1 to C9.2.1.100

C9.2.1 Reading Data
C9.2.1.100 Word #100

Range:	0 ... 9999	Default: 0
Properties:	Stopped	

Description:

It selects the address (Net Id) of the parameter whose content should be provided in the reading area for the fieldbus interfaces (input: sent to the network master).

The size of the referenced parameter must be taken into account. If the data size is greater than 16 bits, the configuration parameter of the next programmable word must be set to the same address.

C9.2.2 Writing Data

It configures a set of 16-bit parameters to be written via communication network.

C9.2.2 Writing Data
C9.2.2.2 Word #1

C9.2.2.2 to C9.2.2.101

C9.2.2 Writing Data
C9.2.2.101 Word #100

Range:	0 ... 9999	Default: 0
Properties:	Stopped	

Description:

It selects the address (Net Id) of the parameter whose content should be provided in the writing area for the fieldbus interfaces (output: received from the network master).

The size of the referenced parameter must be taken into account. If the data size is greater than 16 bits, the configuration parameter of the next programmable word must be set to the same address.

C9.8 CAN/CANopen/DNet

It configures CAN communication accessory and protocols that use this interface.

C9.8 CAN/CANopen/DNet		
C9.8.1 Protocol		
Range:	0 ... 2	Default: 2
Properties:	Stopped	

Description:

It allows selecting the desired protocol for the CAN interface.

Indication	Description
0 = Disabled	It disables the CAN interface.
1 = CANopen	It enables the CAN interface with CANopen protocol.
2 = DeviceNet	It enables the CAN interface with DeviceNet protocol.

C9.8 CAN/CANopen/DNet		
C9.8.2 Address		
Range:	0 ... 127	Default: 63
Properties:	Stopped	

Description:

It allows programming the address used for CAN communication of the device. It is necessary that each device on the network have a different address from the others. Valid addresses for this parameter depend on the protocol selected in C9.8.1:

- C9.8.1 = 1 (CANopen): valid addresses: 1 to 127.
- C9.8.1 = 2 (DeviceNet): valid addresses: 0 to 63.

NOTE!

After changing this configuration, the modification will only take effect if the CAN interface is not exchanging cyclical data with the network.

C9.8 CAN/CANopen/DNet		
C9.8.3 Baud Rate		
Range:	0 ... 5	Default: 0
Properties:	Stopped	

Description:

It allows programming the desired value for the baud rate of the CAN interface in bits per second. This rate must be the same for all devices connected to the network. The supported baud rates for the device depend on the protocol set in C9.8.1:

- C9.8.1 = 1 (CANopen): any rate indicated in this parameter can be used, but it does not have the automatic rate detection function (autobaud).
- C9.8.1 = 2 (DeviceNet): only 500, 250 and 125 Kbit/s rates are supported. Other options enable the automatic rate detection function (autobaud).

For the autobaud function, after a successful detection, the baud rate parameter (C9.8.3) automatically changes to the detected rate. To rerun the autobaud function, it is necessary to change parameter C9.8.3 to one of the autobaud options.

Indication	Description
0 = 1 Mbps/Auto	CAN baud rate (automatic detection for DeviceNet).
1 = Not used/Auto	Automatic detection for DeviceNet.
2 = 500 Kbps	CAN baud rate.
3 = 250 Kbps	CAN baud rate.
4 = 125 Kbps	CAN baud rate.
5 = 100 Kbps/Auto	CAN baud rate (automatic detection for DeviceNet).

NOTE!

After changing this configuration, the modification will only take effect if the CAN interface is not exchanging cyclical data with the network.

C9.8 CAN/CANopen/DNet
C9.8.4 Bus Off Reset

Range: 0 ... 1 **Default:** 0
Properties: Stopped

Description:

It allows programming the behavior of the equipment when detecting a bus off error on the CAN interface.

Indication	Description
0 = Manual	If bus off occurs, A134/F234 will be displayed on the HMI and the communication will be disabled. In case of alarm, the action set in parameter C9.1.2.2 will be executed. For the equipment to communicate again via CAN interface, it will be necessary to disable and enable the interface, or restart the product.
1 = Automatic	If bus off occurs, the communication will be automatically restarted, and the error will be ignored. In this case the alarm will not be displayed on the HMI, and the device will not execute the action described in C9.1.2.2.

6 OPERATION IN THE CANOPEN NETWORK

6.1 ACCESS TO THE DATA

Each slave of the CANopen network has a list called object dictionary that contains all the data accessible via network. Each object of this list is identified with an index, which is used during the equipment configuration as well as during message exchanges. This index is used to identify the object being transmitted.

6.2 CYCLIC DATA

Cyclic data is the data normally used for status monitoring and equipment control. For CANopen protocol, the interface supports 8 receive PDOs and 8 transmit PDOs.

It is necessary the configuration to be made both at the slave and master.

6.3 ACYCLIC DATA

In addition to the cyclic data, the interface also provides acyclic data via SDO. Using this type of communication, you can access any equipment parameter. Access to this type of data is commonly done using instructions for reading or writing data, which should indicate the index and sub-index to the desired parameter. The item 7.4 describes how to address the parameters for CFW900 frequency inverter.

6.4 COMMUNICATION OBJECTS - COB

There is a specific set of objects that are responsible for the communication among the network devices. Those objects are divided according to the type of data and the way they are sent or received by a device. The following communication objects (COBs) are described by the specification:

Table 6.1: Types of Communication Objects (COBs)

Type of object	Description
Service Data Object (SDO)	SDO are objects responsible for the direct access to the object dictionary of a device. By means of messages using SDO, it is possible to indicate explicitly (by the object index) what data is being handled. There are two SDO types: Client SDO, responsible for doing a read or write request to a network device, and the Server SDO, responsible for taking care of that request. Since SDO are usually used for the configuration of a network node, they have less priority than other types of message.
Process Data Object (PDO)	PDO are used for accessing equipment data without the need of indicating explicitly which dictionary object is being accessed. Therefore, it is necessary to configure previously which data the PDO will be transmitting (data mapping). There are also two types of PDO: Receive PDO and Transmit PDO. They are usually utilized for transmission and reception of data used in the device operation, and for that reason they have higher priority than the SDO.
Emergency Object (EMCY)	This object is responsible for sending messages to indicate the occurrence of errors in the device. When an error occurs in a specific device (EMCY producer), it can send a message to the network. In the case that any network device be monitoring that message (EMCY consumer), it can be programmed so that an action be taken (disabling the other devices, error reset, etc.).
Synchronization Object (SYNC)	In the CANopen network, it is possible to program a device (SYNC producer) to send periodically a synchronization message for all the network devices. Those devices (SYNC consumers) will then be able, for instance, to send a certain datum that needs to be made available periodically.
Network Management (NMT)	Every CANopen network needs a master that controls the other devices (slaves) in the network. This master will be responsible for a set of services that control the slave communications and their state in the CANopen network. The slaves are responsible for receiving the commands sent by the master and for executing the requested actions. The protocol describes two types of service: device control service, with which the master controls the state of each network slave, and error control service (Node Guarding an Heartbeat), with which the device sends periodic messages to inform that the connection is active.

All the communication of the slave with the network is performed using those objects, and the data that can be accessed are the existent in the device object dictionary.

6.5 COB-ID

A telegram of the CANopen network is always transmitted by a communication object (COB). Every COB has an identifier that indicates the type of data that is being transported. This identifier, called COB-ID has an 11 bits size, and it is transmitted in the identifier field of a CAN telegram. It can be subdivided in two parts:

Function Code				Address						
bit 10	bit 9	bit 8	bit 7	bit 6	bit 5	bit 4	bit 3	bit 2	bit 1	bit 0

- Function Code: indicates the type of object that is being transmitted.
- Address: indicates with which network device the telegram is linked.

A table with the standard values for the different communication objects is presented next. Notice that the standard value of the object depends on the slave address, with the exception of the COB-ID for NMT and SYNC, which are common for all the network elements. Those values can also be changed during the device configuration stage.

Table 6.2: COB-ID for the different objects

COB	Function Code (bits 10-7)	COB-ID Resultant COB-ID (function + address)
NMT	0000	0
SYNC	0001	128 (80h)
EMCY	0001	129 - 255 (81h - FFh)
PDO1 (tx)	0011	385 - 511 (181h - 1FFh)
PDO1 (rx)	0100	513 - 639 (201h - 27Fh)
PDO2 (tx)	0101	641 - 767 (281h - 2FFh)
PDO2 (rx)	0110	769 - 895 (301h - 37Fh)
PDO3 (tx)	0111	897 - 1023 (381h - 3FFh)
PDO3 (rx)	1000	1025 - 1151 (401h - 47Fh)
PDO4 (tx)	1001	1153 - 1279 (481h - 4FFh)
PDO4 (rx)	1010	1281 - 1407 (501h - 57Fh)
SDO (tx)	1011	1409 - 1535 (581h - 5FFh)
SDO (rx)	1100	1537 - 1663 (601h - 67Fh)
Node Guarding/Heartbeat	1110	1793 - 1919 (701h - 77Fh)

6.6 EDS FILE

Each device on an CANopen network has an EDS configuration file, which contains information about the device functions on the network. This file is used by a master or configuration software to program devices present at CANopen network.

The EDS file is available from WEG website (<http://www.weg.net>). It is important to note if the EDS configuration file is compatible with the firmware version of the CFW900 frequency inverter.

7 OBJECT DICTIONARY

The object dictionary is a list containing several equipment data which can be accessed via CANopen network. An object of this list is identified by means of a 16-bits index, and it is based in that list that all the data exchange between devices is performed.

The CiA DS 301 document defines a set of minimum objects that every CANopen network slave must have. The objects available in that list are grouped according to the type of function they execute. The objects are arranged in the dictionary in the following manner:

Table 7.1: Object dictionary groupings

Index	Objects	Description
0001h - 025Fh	Data type definition	Used as reference for the data type supported by the system.
1000h - 1FFFh	Communication objects	They are objects common to all the CANopen devices. They contain general information about the equipment and also data for the communication configuration.
2000h - 5FFFh	Manufacturer specific objects	In this range, each CANopen equipment manufacturer is free to define which data those objects will represent.
6000h - 9FFFh	Standardized device objects	This range is reserved to objects that describe the behavior of similar equipment, regardless of the manufacturer.

The other indexes that are not referred in this list are reserved for future use.

7.1 DICTIONARY STRUCTURE

The general structure of the dictionary has the following format:

Index	Object	Name	Type	Access
-------	--------	------	------	--------

- **Index:** indicates directly the object index in the dictionary.
- **Object:** describes which information the index stores (simple variable, array, record, etc.).
- **Name:** contains the name of the object in order to facilitate its identification.
- **Type:** indicates directly the stored data type. For simple variables, this type may be an integer, a float, etc. For arrays, it indicates the type of data contained in the array. For records, it indicates the record format according to the types described in the first part of the object dictionary (indexes 0001h – 0360h).
- **Access:** informs if the object in question is accessible only for reading (ro), for reading and writing (rw), or if it is a constant (const).

For objects of the array or record type, a sub-index that is not described in the dictionary structure is also necessary.

7.2 DATA TYPE

The first part of the object dictionary (index 0001h – 025Fh) describes the data types that can be accessed at a CANopen network device. They can be basic types, as integers and floats, or compound types formed by a set of entries, as records and arrays.

7.3 COMMUNICATION PROFILE - COMMUNICATION OBJECTS

The indexes from 1000h to 1FFFh in the object dictionary correspond to the part responsible for the CANopen network communication configuration. Those objects are common to all the devices, however only a few are obligatory. A list with the objects of this range that are supported by the frequency inverter CFW900 is presented next.

Table 7.2: Object list – Communication Profile

Index	Object	Name	Type	Access
1000h	VAR	device type	UNSIGNED32	ro
1001h	VAR	error register	UNSIGNED8	ro
1005h	VAR	COB-ID SYNC	UNSIGNED32	rw
100Ch	VAR	guard time	UNSIGNED16	rw
100Dh	VAR	life time factor	UNSIGNED8	rw
1016h	ARRAY	consume heartbeat time	UNSIGNED32	rw
1017h	VAR	producer heartbeat time	UNSIGNED16	rw
1018h	RECORD	Identity Object	Identity	ro
Server SDO Parameter				
1200h	RECORD	1st Server SDO parameter	SDO Parameter	ro
Receive PDO Communication Parameter				
1400h	RECORD	1st receive PDO Parameter	PDO CommPar	rw
1401h	RECORD	2nd receive PDO Parameter	PDO CommPar	rw
1402h	RECORD	3rd receive PDO Parameter	PDO CommPar	rw
1403h	RECORD	4th receive PDO Parameter	PDO CommPar	rw
...				
1407h	RECORD	8th receive PDO Parameter	PDO CommPar	rw
Receive PDO Mapping Parameter				
1600h	RECORD	1st receive PDO mapping	PDO Mapping	rw
1601h	RECORD	2nd receive PDO mapping	PDO Mapping	rw
1602h	RECORD	3rd receive PDO mapping	PDO Mapping	rw
1603h	RECORD	4th receive PDO mapping	PDO Mapping	rw
...				
1607h	RECORD	8th receive PDO mapping	PDO Mapping	rw
Transmit PDO Communication Parameter				
1800h	RECORD	1st transmit PDO Parameter	PDO CommPar	rw
1801h	RECORD	2nd transmit PDO Parameter	PDO CommPar	rw
1802h	RECORD	3rd transmit PDO Parameter	PDO CommPar	rw
1803h	RECORD	4th transmit PDO Parameter	PDO CommPar	rw
...				
1807h	RECORD	8th transmit PDO Parameter	PDO CommPar	rw
Transmit PDO Mapping Parameter				
1A00h	RECORD	1st transmit PDO mapping	PDO Mapping	rw
1A01h	RECORD	2nd transmit PDO mapping	PDO Mapping	rw
1A02h	RECORD	3rd transmit PDO mapping	PDO Mapping	rw
1A03h	RECORD	4th transmit PDO mapping	PDO Mapping	rw
...				
1A07h	RECORD	8th transmit PDO mapping	PDO Mapping	rw

These objects can only be read and written via the CANopen network, it is not available via the keypad (HMI) or other network interface. The network master, in general, is the equipment responsible for setting up the equipment before starting the operation. The EDS configuration file brings the list of all supported communication objects.

Refer to item 8 for more details on the available objects in this range of the objects dictionary.

7.4 MANUFACTURER SPECIFIC OBJECTS

For indexes from 2000h to 5FFFh, each manufacture is free to define which objects will be present, and also the type and function of each one. In the case of the CFW900, the whole list of parameters was made available in this object range. It is possible to operate the CFW900 by means of these parameters, carrying out any function that the inverter can execute. The parameters were made available starting from the index 2000h, and by adding their Net Id to this index their position in the dictionary is obtained. To identify how the parameters are distributed in the object dictionary, refer to the item 13.

In order to be able to program the CFW900 operation correctly via the CANopen network, it is necessary to know its

operation through the parameters.

Refer to the CFW900 frequency inverter programming manual for a complete list of the parameters and their detailed description.

8 COMMUNICATION OBJECTS DESCRIPTION

This item describes in detail each of the communication objects available for the CFW900 frequency inverter. It is necessary to know how to operate these objects to be able to use the available functions for the CFW900 frequency inverter communication.

8.1 IDENTIFICATION OBJECT

There is a set of objects in the dictionary which are used for equipment identification; however, they do not have influence on their behavior in the CANopen network.

8.1.1 Object 1000h - Device Type

This object gives a 32-bit code that describes the type of object and its functionality.

Table 8.1: Object 1000h - Device Type

Index	Sub-index	Name	Type	Access	PDO Mapping	Value
1000h	0	Device Type	UNSIGNED32	RO	No	0

This code can be divided into two parts: 16 low-order bits describing the type of profile that the device uses, and 16 high-order bits indicating a specific function according to the specified profile.

8.1.2 Object 1001h - Error Register

This object indicates whether or not an error in the device occurred. The type of error registered for the equipment follows what is described in the table 8.2.

Table 8.2: Object 1001h - Error Register

Index	Sub-index	Name	Type	Access	PDO Mapping	Value
1001h	0	Error register	UNSIGNED8	RO	yes	0

Table 8.3: Structure of the object Error Register

Bit	Meaning
0	Generic error
1	Current
2	Voltage
3	Temperature
4	Communication
5	Reserved (always 0)
6	Reserved (always 0)
7	Manufacturer specific

If the device presents any error, the equivalent bit must be activated. The first bit (generic error) must be activated with any error condition.

8.1.3 Object 1018h - Identity Object

It brings general information about the device.

Table 8.4: Object 1018h - Identity Object

Index	Sub-index	Name	Type	Access	PDO Mapping	Value
1018h	0	Number of the last sub-index	UNSIGNED8	RO	No	4
	1	Vendor ID	UNSIGNED32	RO	No	0000.0123h
	2	Product code	UNSIGNED32	RO	No	0000.1800h
	3	Revision number	UNSIGNED32	RO	No	According to the equipment firmware version
	4	Serial number	UNSIGNED32	RO	No	Different for each CFW900

The vendor ID is the number that identifies the manufacturer at the CiA. The product code is defined by the manufacturer according to the type of product. The revision number represents the equipment firmware version. The sub-index 4 is a unique serial number for each frequency inverter CFW900 in CANopen network.

8.2 SERVICE DATA OBJECTS - SDOS

The SDOs are responsible for the direct access to the object dictionary of a specific device in the network. They are used for the configuration and therefore have low priority, since they do not have to be used for communicating data necessary for the device operation.

There are two types of SDOs: client and server. Basically, the communication initiates with the client (usually the master of the network) making a read (upload) or write (download) request to a server, and then this server answers the request.

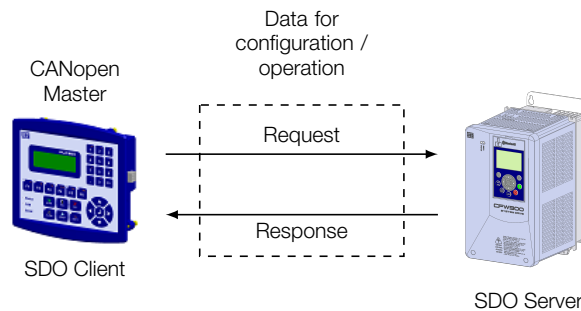

Figure 8.1: Communication between SDO client and server

8.2.1 Object 1200h - SDO Server

The frequency inverter CFW900 frequency inverter has only one SDO of the server type, which makes it possible the access to its entire object dictionary. Through it, an SDO client can configure the communication, the parameters and the the CFW900 operation. Every SDO server has an object, of the SDO_PARAMETER type, for its configuration, having the following structure:

Table 8.5: Objet 1200h - SDO Server

Index	Sub-index	Name	Type	Access	PDO Mapping	Value
1200h	0	Number of the last sub-index	UNSIGNED8	RO	No	2
	1	COB-ID Client - Server (rx)	UNSIGNED32	RO	No	600h + Node-ID
	2	COB-ID Server - Client (tx)	UNSIGNED32	RO	No	580h + Node-ID

8.2.2 SDOs Operation

A telegram sent by an SDO has an 8 byte size, with the following structure:

Identifier	8 data bytes						
11 bits	Command	Index		Subindex	Object data		
	byte 0	byte 1	byte 2	byte 3	byte 4	byte 5	byte 6 byte 7

The identifier depends on the transmission direction (rx or tx) and on the address (or Node-ID) of the destination server. For instance, a client that makes a request to a server which Node-ID is 1, must send a message with the identifier 601h. The server will receive this message and answer with a telegram which COB-ID is equal to 581h.

The command code depends on the used function type. For the transmissions from a client to a server, the following commands can be used:

Table 8.6: Command codes for SDO client

Command	Function	Description	Object Data
22h	Download	Write object	Not defined
23h	Download	Write object	4 byte
2Bh	Download	Write object	2 byte
2Fh	Download	Write object	1 byte
40h	Upload	Read object	Not used
60h ou 70h	Upload segment	Segmented read	Not used

When making a request, the client will indicate through its COB-ID, the address of the slave to which this request is destined. Only one slave (using its respective SDO server) will be able to answer the received telegram to the client. The answer telegram will have also the same structure of the request telegram, the commands however are different:

Table 8.7: Command codes for SDO server

Command	Function	Description	Object Data
60h	Download	Write object	Not used
43h	Upload	Write object	4 byte
4Bh	Upload	Write object	2 byte
4Fh	Upload	Write object	1 byte
41h	Upload segment	Initiates segmented response for read	4 byte
01h ou 0Dh	Upload segment	Last data segment for read	8 ... 2 bytes

For readings of up to four data bytes, a single message can be transmitted by the server; for the reading of a bigger quantity of bytes, it is necessary that the client and the server exchange multiple telegrams.

A telegram is only completed after the acknowledgement of the server to the request of the client. If any error is detected during telegram exchanges (for instance, no answer from the server), the client will be able to abort the process by means of a warning message with the command code equal to 80h.



NOTE!

When the SDO is used for writing in objects that represent the CFW900 parameters (objects starting from the index 2000h), this value is saved in the nonvolatile frequency inverter memory. Therefore, the configured values are not lost after the equipment is switched off or reset. For all the other objects these values are not saved automatically, so that it is necessary to rewrite the desired values.

E.g.: A client SDO requests for a slave at address 1 the reading of the object identified by the index 2000h, sub-index 0 (zero), which represents an 16-bit integer. The master telegram has the following format:

Identifier	Command	Index	Subindex	Data			
601h	40h	00h	20h	00h	00h	00h	00h

The slave responds to the request indicating that the value of the referred object is equal to 999 ¹:

Identifier	Command	Index	Subindex	Data			
581h	4Bh	00h	20h	E7h	03h	00h	00h

8.3 PROCESS DATA OBJECTS - PDOS

The PDOs are used to send and receive data used during the device operation, which must often be transmitted in a fast and efficient manner. Therefore, they have a higher priority than the SDOs.

In the PDOs only data are transmitted in the telegram (index and sub-index are omitted), and in this way it is possible to do a more efficient transmission, with larger volume of data in a single telegram. However it is necessary to configure previously what is being transmitted by the PDO, so that even without the indication of the index and sub-index, it is possible to know the content of the telegram.

There are two types of PDOs, the receive PDO and the transmit PDO. The transmit PDOs are responsible for sending data to the network, whereas the receive PDOs remain responsible for receiving and handling these data. In this way it is possible to have communication among slaves of the CANopen network, it is only necessary to configure one slave to transmit information and one or more slaves to receive this information.

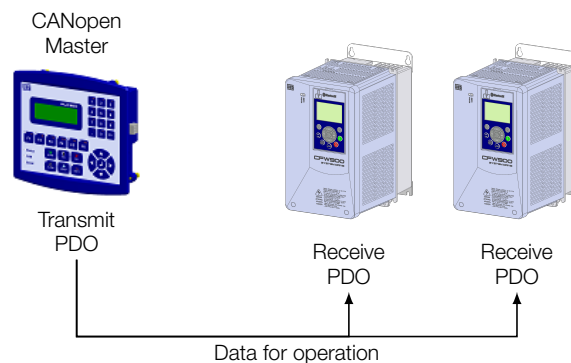

Figure 8.2: Communication using PDOs



NOTE!

PDOs can only be transmitted or received when the device is in the operational state.

8.3.1 PDO Mapping Objects

In order to be able to be transmitted by a PDO, it is necessary that an object be mapped into this PDO content. In the description of communication objects (1000h – 1FFFh), the field “PDO Mapping” informs this possibility. Usually only information necessary for the operation of the device can be mapped, such as enabling commands, device status, reference, etc. Information on the device configuration are not accessible through PDOs, and if it is necessary to access them one must use the SDOs.

For the manufacturer’s specific objects (2000h – 5FFFh), the table 13.1 presents some PDO mapping objects. Read-only parameters (ro) can be used only by transmit PDOs, whereas the other parameters can be used only by receive PDOs.

¹Do not forget that for any integer type of data, the byte transfer order is from the least significant to the most significant.

The EDS file brings the list of all objects available, informing whether the object can be mapped or not.

8.3.2 Receive PDOs

The receive PDOs, or RPDOs, are responsible for receiving data that other devices send to the CANopen network. The frequency inverter CFW900 has 8 receive PDOs, each one being able to receive up to 8 bytes. Each RPDO has two parameters for its configuration, a PDO_COMM_PARAMETER and a PDO_MAPPING, as described next.

PDO_COMM_PARAMETER

Index	Sub-index	Name	Type	Access	PDO Mapping	Value
1400h até 1403h	0	Number of the last sub-index	UNSIGNED8	RO	No	4
	1	COB-ID used by the PDO	UNSIGNED32	RW	No	1400h: 200h + Node-ID 1401h: 300h + Node-ID 1402h: 400h + Node-ID 1403h: 500h + Node-ID 1404h - 1407h: 0
	2	Transmission Type	UNSIGNED8	RW	No	254

The sub-index 1 contains the receive PDO COB-ID. Every time a message is sent to the network, this object will read the COB-ID of that message and, if it is equal to the value of this field, the message will be received by the device. This field is formed by an UNSIGNED32 with the following structure:

Table 8.8: COB-ID description

Bit	Value	Description
31 (MSB)	0	PDO is enabled
	1	PDO is disabled
30	0	RTR permitted
29	0	Identifier size = 11 bits
28 - 11	0	Not used, always 0
10 - 0 (LSB)	X	11-bit COB-ID

The bit 31 allows enabling or disabling the PDO. The bits 29 and 30 must be kept in 0 (zero), they indicate respectively that the PDO accepts remote frames (RTR frames) and that it uses an 11-bit identifier. Since the CFW900 does not use 29-bit identifiers, the bits from 28 to 11 must be kept in 0 (zero), whereas the bits from 10 to 0 (zero) are used to configure the COB-ID for the PDO.

The sub-index 2 indicates the transmission type of this object, according to the next table.

Table 8.9: Transmission type description

Type of transmission	PDOs transmission				
	Cyclic	Acyclic	Synchronous	Asynchronous	RTR
0		•	•		
1 - 240	•		•		
241 - 251	Reserved				
252			•		•
253				•	•
254				•	
255				•	

- **Values 0 – 240:** any RPDO programmed in this range presents the same performance. When detecting a message, it will receive the data; however it won't update the received values until detecting the next SYNC telegram.
- **Values 252 e 253:** not allowed for receive PDOs.

- **Values 254 e 255:** they indicated that there is no relationship with the synchronization object. When receiving a message, its values are updated immediately.

PDO_MAPPING

Index	Sub-index	Name	Type	Access	PDO Mapping	Value
1600h até 1603h	0	Number of mapped objects	0 = disable 1-4=number of mapped objects	RO	No	0
	1 up to 4	1 up to 4 object mapped in the PDO	UNSIGNED32	RW	No	According to EDS file

This parameter indicates the mapped objects in the CFW900 frequency inverter receive PDOs. The default value of these objects is indicated in the product's EDS file. It is possible to map up to 4 different objects for each RPDO, provided that the total length does not exceed eight bytes. The mapping of an object is done indicating its index, sub-index² and size (in bits) in an UNSIGNED32, field with the following format:

UNSIGNED32		
Index (16-bit)	Sub-index (8-bit)	Objects size (8-bit)

For instance, analyzing the receive PDO standard mapping, we have:

- **Sub-index 0 = 2:** This PDO has two mapped objects.
- **Sub-index 1 = 22AD.0010h:** the first mapped object has an index equal to 22ADh, sub-index 0 (zero), and a size of 16 bits. This object corresponds to the parameter S5.7.2 CAN/CANopen/DNet Control Word.
- **Sub-index 2 = 22B8.0010h:** the second mapped object has an index equal to 22B8h, sub-index 0 (zero), and a size of 16 bits. This object corresponds to the parameter S3.1.2.1 Analog Outputs AO1 .

It is possible to modify this mapping by changing the quantity or the number of mapped objects. Remembering that only 4 objects or 8 bytes can be mapped at maximum.

NOTE!

- In order to change the mapped objects in a PDO, it is first necessary to write the value 0 (zero) in the sub-index 0 (zero). In that way the values of the sub-indexes 1 to 4 can be changed. After the desired mapping has been done, one must write again in the sub-index 0 (zero) the number of objects that have been mapped, enabling again the PDO.
- Do not forget that PDOs can only be received if the device is in the operational state.

8.3.3 Transmit PDOs

The transmit PDOs, or TPDOs, as the name says, are responsible for transmitting data for the CANopen network. The frequency inverter CFW900 frequency inverter has 8 transmit PDOs, each one being able to transmit up to 8 data bytes. In a manner similar to RPDOs, each TPDO has two parameters for its configuration, a PDO_COMM_PARAMETER and a PDO_MAPPING, as described next.

PDO_COMM_PARAMETER

²If the object is of the VAR type and does not have sub-index, the value 0 (zero) must be indicated for the sub-index.

Index	Sub-index	Name	Type	Access	PDO Mapping	Value
1800h-1803h	0	Number of the last sub-index	UNSIGNED8	RO	No	5
	1	COB-ID used by the PDO	UNSIGNED32	RW	No	1800h: 180h + Node-ID 1801h: 280h + Node-ID 1802h: 380h + Node-ID 1803h: 480h + Node-ID 1804h - 1807h: 0
	2	Transmission Type	UNSIGNED8	RW	No	254
	3	Time between transmissions	UNSIGNED16	RW	No	-
	4	Reserved	UNSIGNED8	RW	No	-
	5	Event timer	UNSIGNED16	RW	No	0

The sub-index 1 contains the transmit PDO COB-ID. Every time this PDO sends a message to the network, the identifier of that message will be this COB-ID. The structure of this field is described in table 8.8.

The sub-index 2 indicates the transmission type of this object, which follows the table 8.9 description. Its working is however different for transmit PDOs:

- **Value 0:** indicates that the transmission must occur immediately after the reception of a SYNC telegram, but not periodically.
- **Values 1 – 240:** the PDO must be transmitted at each detected SYNC telegram (or multiple occurrences of SYNC, according to the number chosen between 1 and 240).
- **Value 252:** indicates that the message content must be updated (but not sent) after the reception of a SYNC telegram. The transmission of the message must be done after the reception of a remote frame (RTR frame).
- **Value 253:** the PDO must update and send a message as soon as it receives a remote frame.
- **Value 254:** The object must be transmitted according to the timer programmed in sub-index 5.
- **Value 255:** the object is transmitted automatically when the value of any of the objects mapped in this PDO is changed. It works by changing the state (Change of State). This type does also allow that the PDO be transmitted according to the timer programmed in sub-index 5.

In the sub-index 3 it is possible to program a minimum time (in multiples of 100 µs) that must elapse after the a telegram has been sent, so that a new one can be sent by this PDO. The value 0 (zero) disables this function.

The sub-index 5 contains a value to enable a timer for the automatic sending of a PDO. Therefore, whenever a PDO is configured as the asynchronous type, it is possible to program the value of this timer (in multiples of 1 ms), so that the PDO is transmitted periodically in the programmed time.

NOTE!

CFW900 does not support PDO transmission on receipt of a remote frame (RTR) initiated by a PDO consumer.

NOTE!

- The value of this timer must be programmed according to the used transmission rate. Very short times (close to the transmission time of the telegram) are able to monopolize the bus, causing indefinite retransmission of the PDO, and avoiding that other less priority objects transmit their data
- The minimum time allowed for this Function in the frequency inverter CFW900 is 2 ms.
- It is important to observe the time between transmissions programmed in the sub-index 3, especially when the PDO is programmed with the value 255 in the sub-index 2 (Change of State).
- Do not forget that PDOs can only be received if the slave is in the operational state.

Index	Sub-index	Name	Type	Access	PDO Mapping	Value
1A00h-1A03h	0	Number of the last sub-index	UNSIGNED8	RO	No	0
	1 - 4	1 up to 4 object mapped in the PDO	UNSIGNED32	RW	No	0

The PDO MAPPING for the transmission works in similar way than for the reception, however in this case the data to be transmitted by the PDO are defined. Each mapped object must be put in the list according to the description showed next:

UNSIGNED32		
Index (16-bit)	Sub-index (8-bit)	Object size (8-bit)

For instance, analyzing the standard mapping of the fourth transmit PDO, we have:

- **Sub-índice 0 = 2:** This PDO has two mapped objects.
- **Sub-índice 1 = 22A8.0010h:** the first mapped object has an index equal to 22A8h, sub-index 0 (zero), and a size of 16-bit. This object corresponds to the parameter S5.1.1 Status and Commands Status Word 1.
- **Sub-índice 2 = 2018.0020h:** the second mapped object has an index equal to 2018h, sub-index 0 (zero), and a size of 32-bit. This object corresponds to the parameter S2.3.1 Inverter Output Current.

It is possible to modify this mapping by changing the quantity or the number of mapped objects. Remember that a maximum of 4 objects or 8 bytes can be mapped.



NOTE!

In order to change the mapped objects in a PDO, it is first necessary to write the value 0 (zero) in the sub-index 0 (zero). In that way the values of the sub-indexes 1 to 4 can be changed. After the desired mapping has been done, one must write again in the sub-index 0 (zero) the number of objects that have been mapped, enabling again the PDO.

8.4 SYNCHRONIZATION OBJECT - SYNC

This object is transmitted with the purpose of allowing the synchronization of events among the CANopen network devices. It is transmitted by a SYNC producer, and the devices that detect its transmission are named SYNC consumers.

The frequency inverter CFW900 has the function of a SYNC consumer and, therefore, it can program its PDOs to be synchronous. Synchronous PDOs are those related to the synchronization object, thus they can be programmed to be transmitted or updated based in this object.

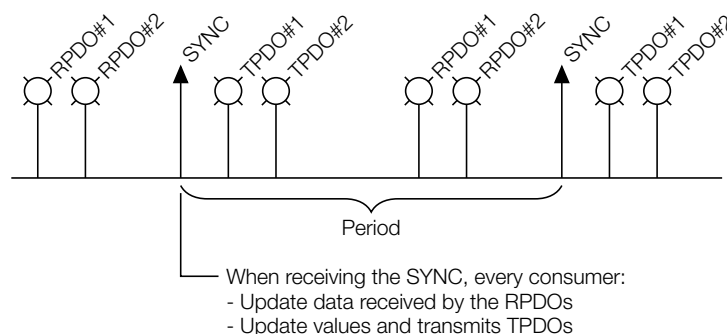

Figure 8.3: SYNC

The SYNC message transmitted by the producer does not have any data in its data field, because its purpose is to provide a time base for the other objects. The following object is available for the configuration of the SYNC consumer:

Index	Sub-index	Name	Type	Access	PDO Mapping	Value
1005h	0	COB-ID SYNC	UNSIGNED32	RW	No	80h

NOTE!

The period of the SYNC telegrams must be programmed in the producer according to the transmission rate and the number of synchronous PDOs to be transmitted. There must be enough time for the transmission of these objects, and it is also recommended that there is a tolerance to make it possible the transmission of asynchronous messages, such as EMCY, asynchronous PDOs and SDOs.

8.5 NETWORK MANAGEMENT - NMT

The network management object is responsible for a series of services that control the communication of the device in a CANopen network. For this object, the services of node control and error control are available (using Node Guarding or Heartbeat).

8.5.1 Slave State Control

With respect to the communication, a CANopen network device can be described by the following state machine:

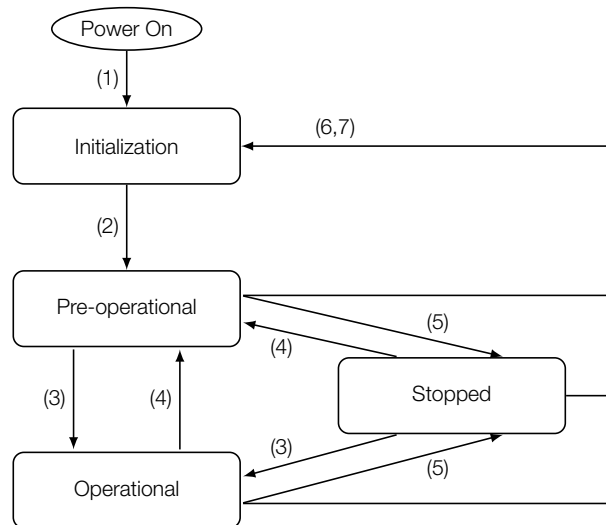

Figure 8.4: CANopen node state diagram

Table 8.10: Transitions Description

Transition	Description
1	The device is switched on and initiates the initialization (automatic)
2	Initialization concluded, it goes to the preoperational state (automatic)
3	It receives the Start Node command for entering the operational state
4	It receives the Enter Pre-Operational command, and goes to the preoperational state
5	It receives the Stop Node command for entering the stopped state
6	It receives the Reset Node command, when it executes the device complete reset
7	It receives the Reset Communication command, when it reinitializes the object values and the CANopen device communication

During the initialization the Node-ID is defined, the objects are created and the interface with the CAN network is configured. Communication with the device is not possible during this stage, which is concluded automatically. At

the end of this stage the slave sends to the network a telegram of the Boot-up Object, used only to indicate that the initialization has been concluded and that the slave has entered the preoperational state. This telegram has the identifier 700h + Node-ID, and only one data byte with value equal to 0 (zero).

In the preoperational state it is already possible to communicate with the slave. But its PDOs are not yet available for operation. In the operational state all the objects are available, whereas in the stopped state only the NMT object can receive or transmit telegrams to the network. The next table shows the objects available for each state.

Table 8.11: Objects accessible in each state

	Initialization	Préoperational	Operational	Stopped
PDO			•	
SDO		•	•	
SYNC		•	•	
EMCY		•	•	
Boot-up	•			
NMT		•	•	•

This state machine is controlled by the network master, which sends to each slave the commands so that the desired state change be executed. These telegrams do not have confirmation, what means that the slave does only receive the telegram without returning an answer to the master. The received telegrams have the following structure:

Identifier	byte 1	byte 2
00h	Command Code	Destination Node-ID

Table 8.12: Commands for the state transition

Command Code	Destination Node ID
1 = START node (transition 3)	0 = All the slaves
2 = STOP node (transition 4)	1 ... 127 = Specific slave
128 = Enter preoperational (transition 5)	
129 = Reset node (transition 6)	
130 = Reset communication (transition 7)	

The transitions indicated in the command code correspond to the state transitions executed by the node after receiving the command (according to the figure 8.4). The Reset node command makes the slave execute a complete reset of the device, while the Reset communication command causes the device to reinitialize only the objects pertinent to the CANopen communication.

8.5.2 Error Control - Node Guarding

This service is used to make it possible the monitoring of the communication with the CANopen network, both by the master and the slave as well. In this type of service the master sends periodical telegrams to the slave, which responds to the received telegram. If some error that interrupts the communication occurs, it will be possible to identify this error, because the master as well as the slave will be notified by the Timeout in the execution of this service. The error events are called Node Guarding for the master and Life Guarding for the slave.

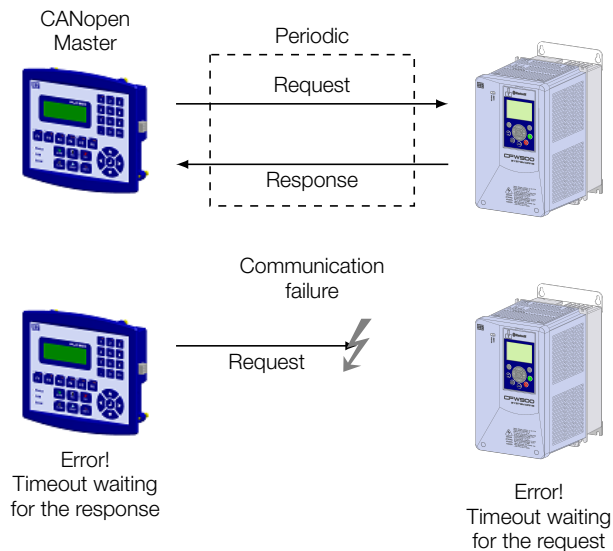

Figure 8.5: Error control service – Node Guarding

There are two objects of the dictionary for the configuration of the error detection times for the Node Guarding service:

Index	Sub-index	Name	Type	Access	PDO Mapping	Value
100Ch	0	Guard Time	UNSIGNED32	RW	No	0

Index	Sub-index	Name	Type	Access	PDO Mapping	Value
100Dh	0	Life Time Factor	UNSIGNED8	RW	No	0

The 100Ch object allows programming the time necessary (in milliseconds) for a fault occurrence being detected, in case the slave does not receive any telegram from the master. The 100Dh object indicates how many faults in sequence are necessary until it be considered that there was really a communication error. Therefore, the multiplication of these two values will result in the total necessary time for the communication error detection using this object. The value 0 (zero) disables this function.

Once configured, the slave starts counting these times starting from the first Node Guarding telegram received from the network master. The master’s telegram is of the remote type, not having data bytes. The identifier is equal to 700h + Node-ID of the destination slave. However the slave response telegram has 1 data byte with the following structure:

Identificador	byte 1	
	bit 7	bit 6 ... 0
700h + Node ID	Toogle	Estado do Escravo

This telegram has one single data byte. This byte contains, in the seven least significant bits, a value to indicate the slave state (4 = stopped, 5 = operational and 127 = preoperational), and in the eighth bit, a value that must be changed at every telegram sent by the slave (toggle bit).

If the frequency inverter CFW900 detects an error using this mechanism, it will turn automatically to the preoperational state and indicate A135/F135 on its HMI.



NOTE!

- This object is active even in the stopped state (see table 8.11).
- The value 0 (zero) in any of these two objects will disable this function.
- If after the error detection the service is enabled again, then the error indication will be removed from the HMI.
- The minimum value accepted by the CFW900 frequency inverter is 2 ms. But considering the transmission rate and the number of nodes in the network, the times programmed for this function must be consistent, so that there is enough time for the transmission of the telegrams and also that the rest of the communication be able to be processed.
- For any slave only one of the two services - Heartbeat or Node Guarding – can be enabled.

8.5.3 Error Control - Heartbeat

The error detection through the Heartbeat mechanism is done using two types of objects: the Heartbeat producer and the Heartbeat consumer. The producer is responsible for sending periodic telegrams to the network, simulating a heartbeat, indicating that the communication is active and without errors. One or more consumers can monitor these periodic telegrams, and if they cease occurring, it means that any communication problem occurred.

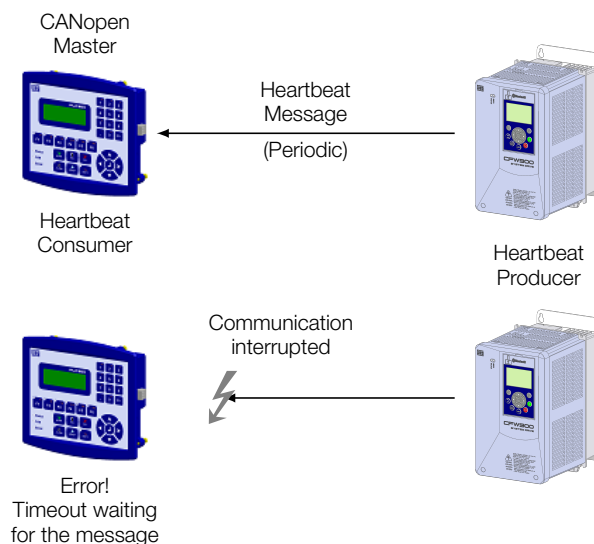

Figure 8.6: Error control service – Heartbeat

One device of the network can be both producer and consumer of heartbeat messages. For example, the network master can consume messages sent by a slave, making it possible to detect communication problems with the master, and simultaneously the slave can consume heartbeat messages sent by the master, also making it possible to the slave detect communication fault with the master.

The CFW900 frequency inverter has the producer and consumer of heartbeat services. As a consumer, it is possible to program up to 4 different producers to be monitored by the equipment:

Index	Sub-index	Name	Type	Access	PDO Mapping	Value
1016h	0	Number of the last sub-index	UNSIGNED8	RO	No	2
	1 - 2	Consumer Heartbeat Time 1 – 2	UNSIGNED32	RW	No	0

At sub-indexes 1 to 2, it is possible to program the consumer by writing a value with the following format:

UNSIGNED32		
Reserved (8-bit)	Node-ID (8-bit)	HeartBeat time (16-bit)

- Node-ID: it allows programming the Node-ID for the heartbeat producer to be monitored.
- Heartbeat time: it allows programming the time, in 1 millisecond multiples, until the error detection if no message of the producer is received. The value 0 (zero) in this field disables the consumer.

Once configured, the heartbeat consumer initiates the monitoring after the reception of the first telegram sent by the producer. In case that an error is detected because the consumer stopped receiving messages from the heartbeat producer, it will turn automatically to the preoperational state and indicate A135/F135 on the HMI display.

As a producer, the CFW900 frequency inverter has an object for the configuration of that service:

Index	Sub-index	Name	Type	Access	PDO Mapping	Value
1017h	0	Producer Heartbeat Time	UNSIGNED8	RW	No	0

The 1017h object allows programming the time in milliseconds during which the producer has to send a heartbeat telegram to the network. Once programmed, the device initiates the transmission of messages with the following format:

Identifier	byte 1	
	bit 7	bit 6 ... 0
700h + Node ID	Always 0	Slave State

NOTE!

- This object is active even in the stopped state (see table 8.11).
- The value 0 (zero) in any of these two objects will disable this function.
- If after the error detection the service is enabled again, then the error indication will be removed from the HMI display.
- The minimum value accepted by the CFW900 frequency inverter is 2 ms. But considering the transmission rate and the number of nodes in the network, the times programmed for this function must be consistent, so that there is enough time for the transmission of the telegrams and also that the rest of the communication be able to be processed.
- For any slave only one of the two services - Heartbeat or Node Guarding – can be enabled.

8.6 INITIALIZATION PROCEDURE

Once the operation of the objects available for the CFW900 frequency inverter is known, then it becomes necessary to program the different objects to operate combined in the network. In a general manner, the procedure for the initialization of the objects in a CANopen network follows the description of the next flowchart:

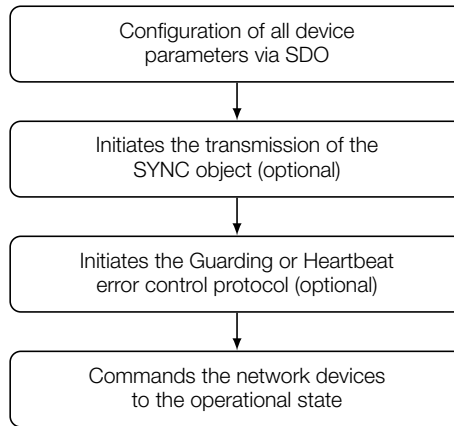

Figure 8.7: Initialization process flowchart

It is necessary to observe that the CFW900 frequency inverter communication objects (1000h to 1FFFh) are not stored in the nonvolatile memory. Therefore, every time the equipment is reset or switched off, it is necessary to redo the communication objects parameter setting. The manufacturer specific objects (starting from 2000h that represents the parameters), they are stored in the nonvolatile memory and, thus, could be set just once.

9 CIA 402 DRIVE PROFILE

The objects that are common for drives, defined by the CANopen specification in the CiA DSP 402 document, are described in this section

The following table presents the list of the available objects for the frequency inverter CFW900, divided according to the different operation modes of the device.

Table 9.1: Object List – Drive Profile

Index	Sub-index	Name	Type	Access	PDO Mapping
Device Control					
6040h	0	ControlWord	UINT16	rw	Yes
6041h	0	StatusWord	UINT16	ro	Yes
6060h	0	Modes of operation	INT8	rw	Yes
6061h	0	Modes of operation display	INT8	ro	Yes
Velocity mode					
6042h	0	vl target velocity	INT16	rw	Yes
6043h	0	vl velocity demand	INT16	ro	Yes
6044h	0	vl control effort	INT16	ro	Yes
6046h	array[3]	vl vl velocity min max amount	UINT32	rw	Yes
6048h	record	vl velocity acceleration	vl vel. accel. decl.	rw	Yes
6049h	record	vl velocity deceleration	vl vel. accel. decl.	rw	Yes
Position Control Function					
6063h	0	Position actual internal value	INT32	ro	Yes

9.1 DEVICE CONTROL

The following figure represents the state machine for controlling the drive.

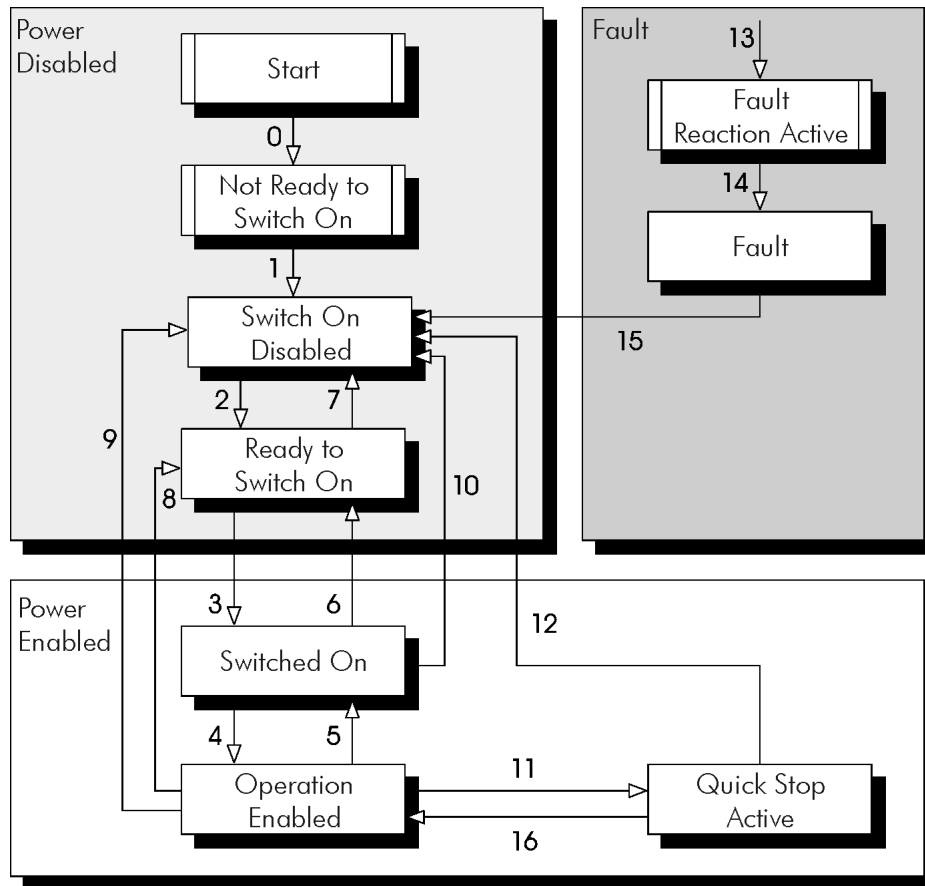

Figure 9.1: State machine for drives

States description:

- **Not ready to switch on:** The drive is initializing, it cannot be commanded.
- **Switch on disabled:** Initialization complete, the drive is able to receive commands.
- **Ready to switch on:** Command to allow powering up the drive has been received.
- **Switched on:** command for powering up the drive has been received.
- **Operation enabled:** the drive is enabled, being controlled according to the programmed operation mode. Power is being applied to the motor.
- **Quick stop active:** during the operation, the quick stop command was received. Power is being applied to the motor.
- **Fault reaction active:** a fault has occurred and the drive is performing the action related to the type of fault.
- **Fault:** drive with fault. disabled function, without power being applied to the motor.

Transitions description:

- ✓ **Transition 0:** the drive is switched on and the initialization procedure starts.
- ✓ **Transition 1:** initialization completed (automatic).
- ✓ **Transition 2:** the *Shutdown* command has been received. The state transition is performed, but no action is taken by the drive.
- ✓ **Transition 3:** the *Switch on* command has been received. The state transition is performed, but no action is taken by the drive.
- ✓ **Transition 4:** the *Enable operation* command has been received. The drive is enabled. It corresponds to activate the bit 1 of the control word of the drive via CANopen – S5.7.2.
- ✓ **Transition 5:** the *Disable operation* command has been received. The drive is disabled. It corresponds to reset the bit 1 of the control word of the drive via CANopen – S5.7.2.
- ✓ **Transition 6:** the *Shutdown* command has been received. The state transition is performed, but no action is taken by the drive.

- ✓ **Transition 7:** the *Quick stop* and *Disable voltage* commands have been received. The state transition is performed, but no action is taken by the drive.
- ✓ **Transition 8:** the *Shutdown* command has been received. During the drive operation it is disabled, blocking the supply to the motor. It corresponds to reset the bit 1 of the control word of the drive via CANopen – S5.7.2.
- ✓ **Transition 9:** the *Disable voltage* command has been received. During the drive operation it is disabled, blocking the supply to the motor. It corresponds to reset the bit 1 of the control word of the drive via CANopen – S5.7.2.
- ✓ **Transition 10:** the *Quick stop* or *Disable voltage* commands have been received. The state transition is performed, but no action is taken by the drive.
- ✓ **Transition 11:** the *Quick stop* command has been received. The drive performs the stopping via ramp function. It corresponds to activate the bit 6 of the control word of the drive via CANopen – S5.7.2.
- ✓ **Transition 12:** the *Disable voltage* command has been received. The drive is disabled. It corresponds to reset the bit 1 of the control word of the drive via CANopen – S5.7.2.
- ✓ **Transition 13:** a fault is detected and the drive is disabled.
- ✓ **Transition 14:** after disabling the drive, it goes to the fault state (automatic).
- ✓ **Transition 15:** the *Fault reset* command has been received. The drive performs the fault reset and returns to the disabled and without fault state. Equivale a ativar o bit 7 da palavra de controle via CANopen – S5.7.2.
- ✓ **Transition 16:** the *Enable operation* command has been received. The drive performs the start via ramp function. It corresponds to activate the bit 0 of the control word of the drive via CANopen – S5.7.2.

This state machine is controlled by the object 6040h, and the other states can be monitored by the object 6041h. Both objects are described next.

9.1.1 Object 6040h – Controlword

It controls the drive state. The bits of this word have the following functions:

Bit	15	14	13	12	11	10	9	8	7	6	5	4	3	2	1	0
Function	Reserved							Halt	Fault reset	Operation mode specific			Enable operation	Quick stop	Enable voltage	Switch on

The bits 0, 1, 2, 3 and 7 allow controlling the drive state machine. The commands for state transitions are given by means of the bit combinations indicated in the table 9.2. The bits marked with “x” are irrelevant for the command execution.

Table 9.2: Control word commands

Command	Control word bits					Transitions
	Fault reset	Enable operation	Quick stop	Enable voltage	Switch on	
Shutdown	0	x	1	1	0	2, 6, 8
Switch on	0	0	1	1	1	3
Disable voltage	0	x	x	0	x	7, 9, 10, 12
Quick stop	0	x	0	1	x	7, 10, 11
Disable operation	0	0	1	1	1	5
Enable operation	0	1	1	1	1	4, 16
Fault reset	0 → 1	x	x	x	x	15

The bits 4, 5, 6 and 8 have different functions according to the used operation mode. The detailed description of the functions of these bits for the velocity mode is presented on the section 9.3. Bits 9 to 15 are reserved for manufacturer specific use.

9.1.2 Object 6041h – Statusword

It indicates the drive present state. The bits of this word have the following functions:

Bit	15	14	13	12	11	10	9	8	7	6	5	4	3	2	1	0
Function	Reserved		Operation mode specific		Internal limit active	Target reached	Remote	Reserved	Warning	Switch on disabled	Quick stop	Voltage enabled	Fault	Operation enabled	Switched on	Ready to switch on

In this word the bits 0, 1, 2, 3, 5 and 6 indicate the state of the device according to the state machine described in the figure 9.1. The table 9.3 describes the combinations of these bits for the state indications. The bits marked with “x” are irrelevant for the state indication.

Table 9.3: Drive states indicated through the Statusword

Value (binary)	State
xxxx xxxx x0xx 0000	Not ready to switch on
xxxx xxxx x1xx 0000	Switch on disabled
xxxx xxxx x01x 0001	Ready to switch on
xxxx xxxx x01x 0011	Switched on
xxxx xxxx x01x 0111	Operation enabled
xxxx xxxx x00x 0111	Quick stop active
xxxx xxxx x0xx 1111	Fault reaction active
xxxx xxxx x0xx 1000	Fault

The other bits indicate a specific condition for the drive.

- **Bit 4 – Voltage enabled:** indicates that the drive power section is powered.
- **Bit 7 – Warning:** indicates that has an active warning. Not used by CFW900.
- **Bit 9 – Remote:** indicates when the drive is in the remote mode and accepts commands via CANopen network. Represents the value of bit 4 of status word - S5.1.1.
- **Bit 10 – Target reached:** indicates when the drive is operating at the reference value, which depends on the used operation mode. It is also set to 1 when the functions Quick stop or Halt are activated.
- **Bit 11 – Internal limit active:** Not used by CFW900.
- **Bits 12 and 13 – Operation mode specific:** they depend on the drive operation mode.

9.1.3 Object 6060h – Modes of Operation

It allows programming the drive operation mode.

Index	Sub-index	Name	Type	Access	PDO Mapping
6060h	0	Modes of Operation	INT8	rw	Yes

9.1.4 Object 6061h – Modes of Operation Display

It indicates the drive operation mode.

Index	Sub-index	Name	Type	Access	PDO Mapping
6061h	0	Modes of Operation Display	INT8	ro	Yes

The value presented at this object follows the same options for object 6060h.

9.2 POSITION CONTROL FUNCTION

This object group is used to describe the operation of the position controller in closed loop.

9.2.1 Object 6063h – Position internal actual value

It represents the actual position of the motor shaft in increments. A complete revolution represents 65536 increments.

Index	Sub-index	Name	Type	Access	PDO Mapping
6063h	0	Position actual value	INT32	ro	Yes

The value of this object always represents the shaft position in a single revolution only. The number of revolutions is not controlled by this object.

9.3 VELOCITY MODE

This operation mode allows the control of the inverter in a simple manner, making available functions of the following type:

- Reference value calculation.
- Capture and monitoring of the speed.
- Speed limitation.
- Speed ramps, among other functions.

These functions are executed based on a set of objects for the configuration of that operation mode.

9.3.1 Control and Status Bits

The bits 4, 5, 6 and 8 of the control word (6040h object – Control word) have the following functions in the velocity mode:

Table 9.4: Velocity Mode – definition of bits 4, 5, 6 and 8

Bit	Name	Value	Definition
4			Reserved
5			Reserved
6	rfg use ref (ramp enabling)	0	Ramp disabling – bit 0 do P0684 = 0.
		1	Ramp enabling – bit 0 do P0684 = 1.
8	Halt	0	Ramp enabling – bit 0 do P0684 = 1.
		1	Ramp disabling – bit 0 do P0684 = 0.

For the Statusword, the bits specified in the operation mode (bits 12 and 13) are reserved for future use.

9.3.2 Object 6042h – vl target velocity

It allows programming the speed reference for the inverter, in rpm:

Index	Sub-index	Name	Type	Access	PDO Mapping
6042h	0	vl target velocity	INT16	rw	Yes

The object vl target velocity allows the writing of negative speed reference values in order to run the motor in the reverse speed direction.

9.3.3 Object 6043h – vl velocity demand

It indicates the value of the speed reference after the ramp, in rpm:

Index	Sub-index	Name	Type	Access	PDO Mapping
6043h	0	vl velocity demand	INT16	ro	Yes

9.3.4 Object 6044h – vl control effort

It indicates the speed value according to the measured at the motor, in rpm. For the control modes without feedback, this object has the same value as the object 6043h.

Index	Sub-index	Name	Type	Access	PDO Mapping
6044h	0	vl control effort	INT16	ro	Yes

9.3.5 Object 6046h – vl velocity min max amount

It allows programming the value of the minimum and the maximum speed for the inverter. Only positive values are accepted, however the programmed values are also valid for the reverse speed direction. The values are written in rpm.

Index	Sub-index	Name	Type	Access	PDO Mapping
6046h	0	Number Of Entries	UINT32	ro	No
	1	vl velocity min amount	UINT32	rw	Yes
	2	vl velocity max amount	UINT32	rw	Yes

9.3.6 Object 6048h – vl velocity acceleration

It allows programming the inverter acceleration ramp.

Index	Sub-index	Name	Type	Access	PDO Mapping
6048h	0	Number Of Entries	UINT8	ro	No
	1	delta speed	UINT32	rw	Yes
	2	delta time	UINT16	rw	Yes

The acceleration value is calculated dividing the speed programmed at the sub-index 1 by the time programmed at the sub-index 2. The programmed values must respect the parameter C6.1.1 Speed Control Ramps Acceleration Time allowed value range.

9.3.7 Object 6049h – vl velocity deceleration

It allows programming the inverter deceleration ramp.

Index	Sub-index	Name	Type	Access	PDO Mapping
6049h	0	Number Of Entries	UINT8	ro	No
	1	delta speed	UINT32	rw	Yes
	2	delta time	UINT16	rw	Yes

The deceleration value is calculated dividing the speed programmed at the sub-index 1 by the time programmed at the sub-index 2. The programmed values must respect the parameter C6.1.2 Speed Control Ramps Deceleration Time allowed value range.

10 STARTUP GUIDE

The main steps to start up the CFW900 frequency inverter in CANopen network are described below. These steps represent an example of use. Check out the specific chapters for details on the indicated steps.

10.1 INSTALLING THE ACCESSORY

1. Install the communication accessory, as indicated in the installation guide supplied with the accessory.
2. Observe the content of parameter S1.4.X. Check if the module was recognized. The detection is done automatically and does not require the user's intervention.
3. Connect the cable to the accessory, considering the recommended instructions in network installation, as described in item 3.5:
 - Use shielded cable.
 - Properly ground network equipment.
 - Avoid laying communication cables next to power cables.

10.2 CONFIGURING THE EQUIPMENT

1. Follow the recommendations described in the user manual to program the device parameters related to the motor parameterization, desired functions for the I/O signals, etc.
2. Program the command sources as desired for the application in menu C4.
3. Configure communication parameters, such as address and baudrate in C9.8.
4. Program the desired action for the equipment in case of communication fault in C9.1.

10.3 CONFIGURING THE MASTER

The way the network configuration is done depends greatly on the used client and the configuration tool. It is essential to know the tools used to perform this activity. In general, the following steps are necessary to perform the network configuration.

1. Load the EDS file³ to the list of devices in the network configuration tool.
2. Select CFW900 frequency inverter from the available list of devices on the network configuration tool. This can be done manually or automatically, if allowed by the tool.
3. During the configuration of the network, it is necessary to define which data will be read and written at frequency inverter CFW900 by configuring the transmission and reception PDOs as described in item 8.3. Among the main parameters that can be used to control the device, we can mention:
 - S5.1.1 Status and Commands Status Word 1 (read)
 - S5.1.3 Status and Commands Status Word 2 (read)
 - S5.7.2 CAN/CANopen/DNet Control Word (write)
4. Configure error control using the Node Guarding or Heartbeat services as described in item 8.5.

Once configured, the network status S5.7.9 indicates Comm. Enabled or Error Ctrl. Enab. and the node state S5.7.10 indicates Operational. It is in this condition that PDO transmission and reception effectively occurs.

³The EDS file is available from WEG website (<http://www.weg.net>). It is important to note if the EDS configuration file is compatible with the firmware version of the CFW900 frequency inverter.

10.4 COMMUNICATION STATUS

Once the network is assembled and the client programmed, it is possible to use the MS LED and parameters of the equipment to identify some status related to the communication.

- The parameters S5.7.9 and S5.7.10 indicate the status of CANopen communication.

The master of the network must also supply information about the communication with the slave.

10.5 OPERATION USING PROCESS DATA

Once the communication is established, the data mapped in the PDOs is automatically updated. Among the main parameters that can be used to control the device, we can mention:

- S5.1.1 Status and Commands Status Word 1
- S5.1.3 Status and Commands Status Word 2
- S5.7.2 CAN/CANopen/DNet Control Word

It is important to know these parameters to program the master as desired for the application.

10.6 ACCESS TO PARAMETERS – ACYCLIC MESSAGES

Besides the cyclic communication using PDOs, the CANopen protocol also defines a kind of acyclic message via SDO, used especially in asynchronous tasks, such as parameter setting and configuration of the equipment.

The EDS file provides the full parameter list of the equipment, which can be accessed via SDO. The item 7.4 describes how to address the parameters of the frequency inverter CFW900 via SDO.

11 FAULTS AND ALARMS

Fault/Alarm	Description	Possible Causes
A133: No Power Supply on the CAN Interface	It actuates when the CAN interface is powered and lack of power supply to the interface is detected. Note: - Measure if there is voltage within the allowed range between pins 1 and 5 of the CAN interface connector.	<ul style="list-style-type: none"> - CAN interface without power supply between pins 1 and 5 of the connector. - Power cables mixed up or reversed. - Poor contact on the CAN interface cable or connector.
A134: Bus Off	Bus off error detection on the CAN interface. If the number of reception or transmission errors detected by the CAN interface is too high, the CAN controller can be taken to the bus off state, where it interrupts the communication and disables the CAN interface. In order to restore communication, it is necessary to turn the product off and on again, or to remove and reconnect the power to the CAN interface, so that communication can be restarted.	<ul style="list-style-type: none"> - Short circuit in the CAN circuit transmission cables. - Changed or reversed cables. - Network devices with different baud rates. - Termination resistors with incorrect values. - Termination resistors installed at one end of the main bus only. - CAN network installation done improperly.
A135: CANopen Off-line	It occurs if the state of the CANopen node changes from operational to pre-operational. Note: - Check the operation of the error control mechanisms (Heartbeat/Node Guarding).	<ul style="list-style-type: none"> - The master is not sending the guarding/heartbeat telegrams at the programmed time. - Communication problems caused by lost telegrams or transmission delays.
F233: No Power Supply on the CAN Interface	It actuates when the CAN interface is powered and lack of power supply to the interface is detected. Note: - Measure if there is voltage within the allowed range between pins 1 and 5 of the CAN interface connector.	<ul style="list-style-type: none"> - CAN interface without power supply between pins 1 and 5 of the connector. - Power cables mixed up or reversed. - Poor contact on the CAN interface cable or connector.
F234: Bus Off	Bus off error detection on the CAN interface. If the number of reception or transmission errors detected by the CAN interface is too high, the CAN controller can be taken to the bus off state, where it interrupts the communication and disables the CAN interface. In order to restore communication, it is necessary to turn the product off and on again, or to remove and reconnect the power to the CAN interface, so that communication can be restarted.	<ul style="list-style-type: none"> - Short circuit in the CAN circuit transmission cables. - Changed or reversed cables. - Network devices with different baud rates. - Termination resistors with incorrect values. - Termination resistors installed at one end of the main bus only. - CAN network installation done improperly.
F235: CANopen Off-line	It occurs if the state of the CANopen node changes from operational to pre-operational. Note: - Check the operation of the error control mechanisms (Heartbeat/Node Guarding).	<ul style="list-style-type: none"> - The master is not sending the guarding/heartbeat telegrams at the programmed time. - Communication problems caused by lost telegrams or transmission delays.

12 PARAMETER STRUCTURE

S Status

- └ S1 Inverter
 - └ S1.1 Status
 - └ S1.2 Software Version
 - └ S1.2.2 Details
 - └ S1.3 Inverter Data
 - └ S1.4 Control Accessory Data
 - └ S1.4.1 Backplane
 - └ S1.4.2 Slot A
 - └ S1.4.3 Slot B
 - └ S1.4.4 Slot C
 - └ S1.4.5 Slot D
 - └ S1.4.6 Slot E
 - └ S1.4.7 Slot F
 - └ S1.4.8 Slot G
 - └ S1.5 Date/Hour
 - └ S1.6 Control Words
- └ S2 Measurements
 - └ S2.1 Motor Speed
 - └ S2.2 Motor Torque
 - └ S2.3 Inverter Output
 - └ S2.4 Motor Temperatures
 - └ S2.5 Inverter Temperatures
 - └ S2.5.1 IGBT Temperature
 - └ S2.5.3 Internal Air Temperature
 - └ S2.7 DC Link
 - └ S2.8 Torque Current Limitation
- └ S3 I/Os
 - └ S3.1 Slot X Status
 - └ S3.1.1 Analog Inputs
 - └ S3.1.2 Analog Outputs
 - └ S3.1.3 Digital Inputs
 - └ S3.1.4 Digital Outputs
 - └ S3.1.5 Encoder
 - └ S3.2 Slot A Status
 - └ S3.2.1 Analog Inputs
 - └ S3.2.2 Analog Outputs
 - └ S3.2.3 Digital Inputs
 - └ S3.2.4 Digital Outputs
 - └ S3.2.5 Encoder
 - └ S3.2.6 Temperatures
 - └ S3.3 Slot B Status
 - └ S3.4 Slot C Status
 - └ S3.5 Slot D Status

S Status (cont.)

- └ S3 I/Os (cont.)
 - └ S3.6 Slot E Status
 - └ S3.7 Slot F Status
 - └ S3.8 Slot G Status
- └ S4 Functional Safety
- └ S5 Communications
 - └ S5.1 Status and Commands
 - └ S5.2 Serial RS485
 - └ S5.3 Ethernet
 - └ S5.4 EtherNet/IP
 - └ S5.5 Modbus TCP
 - └ S5.6 Anybus
 - └ S5.7 CAN/CANopen/DNet
 - └ S5.9 Bluetooth
- └ S6 SoftPLC
 - └ S6.1 Program Execution
 - └ S6.2 Control and References
- └ S7 User

D Diagnostics

- └ D1 Faults
 - └ D1.1 Actual
 - └ D1.2 History
 - └ D1.3 Simplified History
- └ D2 Alarms
 - └ D2.1 Actual
 - └ D2.2 History
 - └ D2.3 Simplified History
- └ D3 Hour Control
- └ D4 Inverter and Control Access.
 - └ D4.1 Inverter
 - └ D4.1.1 Fan Speed
 - └ D4.1.2 Temperatures
 - └ D4.1.3 DC Link
 - └ D4.1.4 Control Voltages
 - └ D4.1.5 Motor Overl. Fault
 - └ D4.1.6 Thermal Management
 - └ D4.2 Control Accessories
 - └ D4.2.1 Diag. Slot A
 - └ D4.2.2 Diag. Slot B
 - └ D4.2.3 Diag. Slot C
 - └ D4.2.4 Diag. Slot D
 - └ D4.2.5 Diag. Slot E

D Diagnostics (cont.)

- └ D4 Inverter and Control Access. (cont.)
 - └ D4.2 Control Accessories (cont.)
 - └ D4.2.6 Diag. Slot F
 - └ D4.2.7 Diag. Slot G
- └ D5 Changed Parameters
 - └ D5.1 Configurations
 - └ D5.2 Application

C Configurations

- └ C1 Inverter and Power Supply
 - └ C1.1 Power Supply
 - └ C1.2 Inverter Use
 - └ C1.3 Switching Frequency
 - └ C1.4 PWM Modulation
 - └ C1.5 Fans Configuration
 - └ C1.6 Other Inverter Settings
- └ C2 Motor
 - └ C2.1 Motor Data
 - └ C2.2 Motor Model Parameters
- └ C3 Control
 - └ C3.1 Configuration
 - └ C3.2 Scalar and VVW+ Control
 - └ C3.2.1 V/F Curve
 - └ C3.2.2 VVW+ Optimization
 - └ C3.2.2.1 VVW+ Induction Motor
 - └ C3.2.2.2 VVW+ Synchronous Motor
 - └ C3.2.3 Current Stabilization
 - └ C3.2.4 Pre-Magnetization
 - └ C3.2.5 I/F Control
 - └ C3.3 Vector Control
 - └ C3.3.1 Configuration
 - └ C3.3.2 Regulators
 - └ C3.3.2.1 Speed Regulator
 - └ C3.3.2.2 Torque Regulator
 - └ C3.3.2.3 Flux Regulator
 - └ C3.3.2.4 Current Regulator
 - └ C3.3.3 Output Voltage Limiter
 - └ C3.3.4 Torque Mode
 - └ C3.3.4.1 Speed Limiter
 - └ C3.3.5 Speed Mode
 - └ C3.3.5.1 Torque Limiter
 - └ C3.3.7 Speed Steady State Estimator
 - └ C3.3.8 Low Speed Estimator

C Configurations (cont.)

- └─ C3 Control (cont.)
 - └─ C3.3 Vector Control (cont.)
 - └─ C3.3.9 Online Parameters Estimator
 - └─ C3.3.10 Maximum Torque per Ampere
 - └─ C3.4 Current Limiter
 - └─ C3.5 DC Link Voltage Limiter
 - └─ C3.5.1 DC Link Volt. Limit. Config.
 - └─ C3.5.2 Scalar and VVW+ Control
 - └─ C3.5.3 Vector Control
 - └─ C3.6 Dynamic Braking
 - └─ C3.7 DC Braking
 - └─ C3.8 Flying Start
 - └─ C3.8.1 Flying Start Setting
 - └─ C3.8.2 Scalar and VVW+ Control
 - └─ C3.8.3 Vector Control
 - └─ C3.9 Ride-Through
 - └─ C3.9.1 Ride-Through Config.
 - └─ C3.9.2 Scalar and VVW+ Control
 - └─ C3.9.3 Vector Control
 - └─ C3.10 Advanced Energy Saving
- └─ C4 Commands and References
 - └─ C4.1 LOC/REM Mode Config.
 - └─ C4.2 Commands
 - └─ C4.2.1 R1 Command Config.
 - └─ C4.2.2 R2 Command Config.
 - └─ C4.2.3 DI Config. for Commands
 - └─ C4.2.4 HMI Config. for Commands
 - └─ C4.3 References
 - └─ C4.3.1 Speed
 - └─ C4.3.1.1 Speed Ref. Range
 - └─ C4.3.1.2 Speed Ref. Source
 - └─ C4.3.1.3 Ref. HMI, Als and Fls
 - └─ C4.3.1.4 E.P. Ref.-DIs Config.
 - └─ C4.3.1.5 Multispeed Ref.
 - └─ C4.3.1.6 Skip Speed
 - └─ C4.3.2 JOG Speed
 - └─ C4.3.3 Torque
- └─ C5 I/Os
 - └─ C5.1 Slot X
 - └─ C5.1.1 Slot X - Analog Inputs
 - └─ C5.1.2 Slot X - Analog Outputs
 - └─ C5.1.3 Slot X - Digital Inputs
 - └─ C5.1.4 Slot X - Digital Outputs

C Configurations (cont.)

- └─ C5 I/Os (cont.)
 - └─ C5.1 Slot X (cont.)
 - └─ C5.1.5 Slot X-Encoder
 - └─ C5.2 Slot A
 - └─ C5.2.1 Slot A-Analog Inputs
 - └─ C5.2.2 Slot A - Analog Outputs
 - └─ C5.2.4 Slot A - Digital Outputs
 - └─ C5.2.5 Slot A-Encoder
 - └─ C5.2.6 Slot A-Temperatures
 - └─ C5.3 Slot B
 - └─ C5.3.1 Slot B-Analog Inputs
 - └─ C5.3.2 Slot B-Analog Outputs
 - └─ C5.3.4 Slot B-Digital Outputs
 - └─ C5.3.5 Slot B-Encoder
 - └─ C5.3.6 Slot B-Temperatures
 - └─ C5.4 Slot C
 - └─ C5.4.1 Slot C-Analog Inputs
 - └─ C5.4.2 Slot C-Analog Outputs
 - └─ C5.4.4 Slot C-Digital Outputs
 - └─ C5.4.5 Slot C-Encoder
 - └─ C5.4.6 Slot C-Temperatures
 - └─ C5.5 Slot D
 - └─ C5.5.1 Slot D-Analog Inputs
 - └─ C5.5.2 Slot D-Analog Outputs
 - └─ C5.5.4 Slot D-Digital Outputs
 - └─ C5.5.5 Slot D-Encoder
 - └─ C5.5.6 Slot D-Temperatures
 - └─ C5.6 Slot E
 - └─ C5.6.1 Slot E-Analog Inputs
 - └─ C5.6.2 Slot E-Analog Outputs
 - └─ C5.6.4 Slot E-Digital Outputs
 - └─ C5.6.5 Slot E-Encoder
 - └─ C5.6.6 Slot E-Temperatures
 - └─ C5.7 Slot F
 - └─ C5.7.1 Slot F-Analog Inputs
 - └─ C5.7.2 Slot F-Analog Outputs
 - └─ C5.7.4 Slot F-Digital Outputs
 - └─ C5.7.5 Slot F-Encoder
 - └─ C5.7.6 Slot F-Temperatures
 - └─ C5.8 Slot G
 - └─ C5.8.1 Slot G-Analog Inputs
 - └─ C5.8.2 Slot G-Analog Outputs
 - └─ C5.8.4 Slot G-Digital Outputs

C Configurations (cont.)

- └─ C5 I/Os (cont.)
 - └─ C5.8 Slot G (cont.)
 - └─ C5.8.5 Slot G-Encoder
 - └─ C5.8.6 Slot G-Temperatures
 - └─ C5.9 DO Operation Levels
 - └─ C5.10 DOs delay
- └─ C6 Ramps
 - └─ C6.1 Speed Control Ramps
 - └─ C6.2 Torque Control Ramps
- └─ C7 Protections
 - └─ C7.1 Power Supply Phase Loss
 - └─ C7.2 Ground Fault
 - └─ C7.3 Motor Current Unbal.
 - └─ C7.4 Motor Overload Fault
 - └─ C7.5 Over/Undertemp. Prot.
 - └─ C7.6 Fan Speed Fault
 - └─ C7.7 Motor Overspeed
 - └─ C7.8 Pre-charge
 - └─ C7.9 Auto-Reset
 - └─ C7.10 External Fault/Alarm
 - └─ C7.11 Thermal Management
 - └─ C7.12 Encoder
 - └─ C7.13 History
- └─ C8 Functional Safety
- └─ C9 Communications
 - └─ C9.1 Communication Errors
 - └─ C9.1.1 Master Offline
 - └─ C9.1.2 Master Idle/Prog
 - └─ C9.2 I/O Data
 - └─ C9.2.1 Reading Data
 - └─ C9.2.2 Writing Data
 - └─ C9.3 Serial RS485
 - └─ C9.4 Ethernet
 - └─ C9.5 EtherNet/IP
 - └─ C9.6 Modbus TCP
 - └─ C9.7 Anybus
 - └─ C9.8 CAN/CANopen/DNet
 - └─ C9.9 Bluetooth
 - └─ C9.10 SymbiNet
- └─ C10 SoftPLC
 - └─ C10.1 Configuration
 - └─ C10.2 Engineering Unit
- └─ C11 HMI

C Configurations (cont.)

- ├─ C11 HMI (cont.)
 - ├─ C11.1 Configuration
 - ├─ C11.2 Main Screen
 - ├─ C11.3 User
 - ├─ C11.3.1 Login
 - ├─ C11.3.2 Change password
- ├─ C12 Backup

W Wizards**A Application**

- ├─ A1 User Parameters
- ├─ A2 PID Controller
 - ├─ A2.1 Monitoring
 - ├─ A2.2 Regulation
 - ├─ A2.2.1 Setpoint
 - ├─ A2.2.2 Gains
 - ├─ A2.3 Configuration
 - ├─ A2.3.1 Control
 - ├─ A2.3.2 Setpoint
 - ├─ A2.3.3 Process Variable
 - ├─ A2.3.4 Operating Mode
 - ├─ A2.3.5 Command Sources
 - ├─ A2.3.6 Faults and Alarms
 - ├─ A2.3.7 Sleep Mode

13 QUICK REFERENCES

Table 13.1: Characteristics of parameters for the communication protocol

Parameter	Description	Range of values	Decimal places	Index	Net Id	Size
S1 Status\Inverter						
S1.1	Status					
S1.1.1	Inverter	0 = Ready 1 = Run 2 = Undervoltage 3 = Fault 4 = Configuration 5 = STO 6 = Power Off 7 = Disabled 8 = SS1 9 = Self-tuning 10 = Sleep		2006h	6	enum
S1.1.2	HMI	0 = Ready 1 = Run 2 = Sub 3 = Fault 4 = Config 5 = STO 6 = P.Off 7 = Disab. 8 = SS1 9 = SelfTun 10 = Sleep		23F2h	1010	enum
S1.1.3	Pre-Charge	0 = Running 1 = Completed		2803h	2051	enum
S1.1.4	Config	0 = No Config 1 = Run/Stop Dlx 2 = Forward R1 3 = Forward R2 4 = Reverse R1 5 = Reverse R2 6 = 3-wire Start/Stop 7 = Direction of Rotation Dlx 8 = JOG Dlx 9 = R1/R2 Dlx 10 = Ramp selection Dlx 11 = Oriented Startup 12 = Backup 13 = Not used 14 = SS1 configuration		2031h	49	enum

Parameter	Description	Range of values	Decimal places	Index	Net Id	Size
		15 = Switching Frequency 16 = Undefined model 17 = Encoder Vector Control 18 = ENC Acc. not configured 19 = Alx/Flx Speed Ref. 20 = SM Motor Control 21 = General Enable Dlx 22 = Multispeed 23 = Not used 24 = Electronic Potentiometer 25 = Fl used as DI 26 = Alx/Flx Torque Ref. 27 = SP Source PID 28 = PV Source PID 29 = DI Source PID 30 = Supply Voltage				
S1.2	Software Version					
S1.2.1	Package	to	0	2016h	22	NONE
S1.2.2	Details					
S1.3	Inverter Data					
S1.3.1	Model	1 to 40	0	46ACh	9900	NONE
S1.3.2	Inverter Serial No.	0 to 4294967295	0	2808h	2056	32bit
S1.3.3	Power Board Serial No.	0 to 4294967295	0	280Ah	2058	32bit
S1.3.4	Power - Options/Voltages	Bit 0 = 200 V Bit 1 = 208/220/230/240 V Bit 2 = 380 V Bit 3 = 400/415 V Bit 4 = 440/460 V Bit 5 = 480 V Bit 6 = 500/525 V Bit 7 = 550/575/600 V Bit 8 = 660/690 V Bit 9 = DC Link Power Supply Bit 10 = Single-phase Power Supply Bit 11 = Three-phase Power Supply Bit 12 = Not used		2810h	2064	13bit
S1.3.5	Rated Current	0.0 to 6553.0 A	1	250Fh	1295	16bit
S1.3.6	Effective Rated Current	0.0 to 6553.0 A	1	2513h	1299	16bit
S1.3.7	Inverter Model Version	0 to 4294967295	0	46DEh	9950	32bit
S1.4	Control Accessory Data					
S1.4.1	Backplane					
S1.4.1.1	Model	0 = Disconnected 1 = CFW900-4SLOTS 2 = CFW900-7SLOTS		3B58h	7000	enum
S1.4.2	Slot A					
S1.4.2.1	Accessory Identified	0 = Unknown		3C8Eh	7310	enum

Parameter	Description	Range of values	Decimal places	Index	Net Id	Size
		1 = No Accessory 2 = CFW900-IOAI-01 3 = CFW900-IOD-01 4 = CFW900-REL-01 5 = CFW900-TEMP-01 6 = CFW900-ENC-01 7 = Not used 8 = CFW900-CCAN-W 9 = CFW900-C...-N (Anybus)				
S1.4.3	Slot B					
S1.4.3.1	Accessory Identified	0 = Unknown 1 = No Accessory 2 = CFW900-IOAI-01 3 = CFW900-IOD-01 4 = CFW900-REL-01 5 = CFW900-TEMP-01 6 = CFW900-ENC-01 7 = Not used 8 = CFW900-CCAN-W 9 = CFW900-C...-N (Anybus)		3DBAh	7610	enum
S1.4.4	Slot C					
S1.4.4.1	Accessory Identified	0 = Unknown 1 = No Accessory 2 = CFW900-IOAI-01 3 = CFW900-IOD-01 4 = CFW900-REL-01 5 = CFW900-TEMP-01 6 = CFW900-ENC-01 7 = Not used 8 = CFW900-CCAN-W 9 = CFW900-C...-N (Anybus)		3EE6h	7910	enum
S1.4.5	Slot D					
S1.4.5.1	Accessory Identified	0 = Unknown 1 = No Accessory 2 = CFW900-IOAI-01 3 = CFW900-IOD-01 4 = CFW900-REL-01 5 = CFW900-TEMP-01 6 = CFW900-ENC-01 7 = Not used 8 = CFW900-CCAN-W 9 = CFW900-C...-N (Anybus)		4012h	8210	enum
S1.4.6	Slot E					
S1.4.6.1	Accessory Identified	0 = Unknown 1 = No Accessory		413Eh	8510	enum

Parameter	Description	Range of values	Decimal places	Index	Net Id	Size
		2 = CFW900-IOAI-01 3 = CFW900-IOD-01 4 = CFW900-REL-01 5 = CFW900-TEMP-01 6 = CFW900-ENC-01 7 = Not used 8 = CFW900-CCAN-W 9 = CFW900-C...-N (Anybus)				
S1.4.7	Slot F					
S1.4.7.1	Accessory Identified	0 = Unknown 1 = No Accessory 2 = CFW900-IOAI-01 3 = CFW900-IOD-01 4 = CFW900-REL-01 5 = CFW900-TEMP-01 6 = CFW900-ENC-01 7 = Not used 8 = CFW900-CCAN-W 9 = CFW900-C...-N (Anybus)		426Ah	8810	enum
S1.4.8	Slot G					
S1.4.8.1	Accessory Identified	0 = Unknown 1 = No Accessory 2 = CFW900-IOAI-01 3 = CFW900-IOD-01 4 = CFW900-REL-01 5 = CFW900-TEMP-01 6 = CFW900-ENC-01 7 = Not used 8 = CFW900-CCAN-W 9 = CFW900-C...-N (Anybus)		4396h	9110	enum
S1.5	Date/Hour					
S1.5.1	Actual	0 to 2147483647	0	23F0h	1008	NONE
S1.6	Control Words					
S1.6.1	Global	Bit 0 = Enable Ramp Bit 1 = General Enable Bit 2 = Run Reverse Bit 3 = Enable JOG Bit 4 = R1/R2 Mode Bit 5 = 2nd Ramp Bit 6 = No Quick Stop Bit 7 = Fault Reset		229Ah	666	8bit
S1.6.2	HMI	Bit 0 = Enable Ramp Bit 1 = General Enable Bit 2 = Run Reverse Bit 3 = Enable JOG		229Ch	668	8bit

Parameter	Description	Range of values	Decimal places	Index	Net Id	Size
S1.6.3	DI	Bit 4 = LOC/REM Mode Bit 5 = 2nd Ramp Bit 6 = No Quick Stop Bit 7 = Fault Reset				
		Bit 0 = Enable Ramp Bit 1 = General Enable Bit 2 = Run Reverse Bit 3 = Enable JOG Bit 4 = R1/R2 Mode Bit 5 = 2nd Ramp Bit 6 = No Quick Stop Bit 7 = Fault Reset		229Eh	670	8bit
S2 Status\Measurements						
S2.1	Motor Speed					
S2.1.1	Reference	0 to 60000 rpm	0	2001h	1	16bit
S2.1.2	Total Reference	0 to 60000 rpm	0	23F3h	1011	16bit
S2.1.3	Actual Value	0 to 60000 rpm	0	2002h	2	16bit
S2.1.4	Encoder	0 to 65535 rpm	0	2026h	38	16bit
S2.1.5	Estimated Value	0 to 60000 rpm	0	2027h	39	16bit
S2.2	Motor Torque					
S2.2.1	Reference	-400.0 to 400.0 %	1	200Ch	12	s16bit
S2.2.2	Total Reference	-400.0 to 400.0 %	1	2BFCh	3068	TIME
S2.2.3	Estimated Value	-400.0 to 400.0 %	1	2009h	9	s16bit
S2.3	Inverter Output					
S2.3.1	Current	0.0 to 4500.0 A	1	2003h	3	16bit
S2.3.2	Voltage	0 to 2000 V	0	2007h	7	16bit
S2.3.3	Frequency	0.0 to 1020.0 Hz	1	2005h	5	16bit
S2.3.4	cos phi	-1.00 to 1.00	2	200Bh	11	s16bit
S2.3.5	Power	0.00 to 655.35 kW	2	200Ah	10	16bit
S2.3.6	Energy GWh	0 to 999 GWh	0	2BE5h	3045	16bit
S2.3.7	Energy MWh	0 to 999 MWh	0	2BE6h	3046	16bit
S2.3.8	Energy kWh	0.0 to 999.9 kWh	1	2030h	48	16bit
S2.3.9	Current Switc. Freq.	0.00 to 16.00 kHz	2	2BE0h	3040	16bit
S2.4	Motor Temperatures					
S2.4.1	Thermal Image	0.00 to 655.35 %	2	216Ch	364	16bit
S2.4.3	Sensor Measured Value	-100.0 to 250.0 °C	1	216Dh	365	s16bit
S2.5	Inverter Temperatures					
S2.5.1	IGBT Temperature					
S2.5.1.1	Phase U/T1 IGBT1	-50.0 to 250.0 °C	1	27E4h	2020	s16bit
S2.5.1.2	Phase V/T2 IGBT1	-50.0 to 250.0 °C	1	27E5h	2021	s16bit
S2.5.1.3	Phase W/T3 IGBT1	-50.0 to 250.0 °C	1	27E6h	2022	s16bit
S2.5.3	Internal Air Temperature					
S2.5.3.1	Power	-50.0 to 250.0 °C	1	27EDh	2029	s16bit
S2.5.3.2	Control	-50.0 to 250.0 °C	1	23DEh	990	s16bit
S2.7	DC Link					
S2.7.1	Voltage	0 to 2000 V	0	2004h	4	16bit
S2.8	Torque Current Limitation					

Parameter	Description	Range of values	Decimal places	Index	Net Id	Size
S2.8.1	Alx Global Torque	0.0 to 400.0 %	1	2C12h	3090	16bit
S3 Status\I/Os						
S3.1	Slot X Status					
S3.1.1	Analog Inputs					
S3.1.1.1	AI1	-100.00 to 100.00 %	2	3B69h	7017	s16bit
S3.1.1.2	AI2	-100.00 to 100.00 %	2	3B6Ah	7018	s16bit
S3.1.2	Analog Outputs					
S3.1.2.1	AO1	-100.00 to 100.00 %	2	3B77h	7031	s16bit
S3.1.2.2	AO1 Network	-100.00 to 100.00 %	2	3B7Bh	7035	s16bit
S3.1.2.3	AO1 SoftPLC	-100.00 to 100.00 %	2	3B7Fh	7039	s16bit
S3.1.2.4	AO2	-100.00 to 100.00 %	2	3B78h	7032	s16bit
S3.1.2.5	AO2 Network	-100.00 to 100.00 %	2	3B7Ch	7036	s16bit
S3.1.2.6	AO2 SoftPLC	-100.00 to 100.00 %	2	3B80h	7040	s16bit
S3.1.3	Digital Inputs					
S3.1.3.1	DI	Bit 0 = DI1 Bit 1 = DI2 Bit 2 = DI3 Bit 3 = DI4 Bit 4 = DI5 Bit 5 = DI6		3B68h	7016	6bit
S3.1.3.2	FI5	-100.00 to 100.00 %	2	3BAEh	7086	s16bit
S3.1.3.3	FI5 (Hz)	0 to 32000 Hz	0	3BB0h	7088	16bit
S3.1.3.4	FI6	-100.00 to 100.00 %	2	3BAFh	7087	s16bit
S3.1.3.5	FI6 (Hz)	0 to 32000 Hz	0	3BB1h	7089	16bit
S3.1.4	Digital Outputs					
S3.1.4.1	DO	Bit 0 = DO1 Bit 1 = DO2		3B73h	7027	2bit
S3.1.4.2	DO Network	Bit 0 = DO1 Bit 1 = DO2		3B74h	7028	2bit
S3.1.4.3	DO SoftPLC	Bit 0 = DO1 Bit 1 = DO2		3B75h	7029	2bit
S3.1.4.4	FO1	-100.00 to 100.00 %	2	3BB2h	7090	s16bit
S3.1.4.5	FO1 (Hz)	0 to 32000 Hz	0	3BB4h	7092	16bit
S3.1.4.6	FO1 Network	-100.00 to 100.00 %	2	3BB6h	7094	s16bit
S3.1.4.7	FO1 SoftPLC	-100.00 to 100.00 %	2	3BB8h	7096	s16bit
S3.1.4.8	FO2	-100.00 to 100.00 %	2	3BB3h	7091	s16bit
S3.1.4.9	FO2 (Hz)	0 to 32000 Hz	0	3BB5h	7093	16bit
S3.1.4.10	FO2 Network	-100.00 to 100.00 %	2	3BB7h	7095	s16bit
S3.1.4.11	FO2 SoftPLC	-100.00 to 100.00 %	2	3BB9h	7097	s16bit
S3.1.5	Encoder					
S3.1.5.1	Number of Revolutions	0 to 65535	0	3B63h	7011	16bit
S3.1.5.2	Revolution Fraction	0 to 65535	0	3B64h	7012	16bit
S3.1.5.3	Speed	-60000 to 60000 rpm	0	3B66h	7014	s32bit
S3.2	Slot A Status					

Parameter	Description	Range of values	Decimal places	Index	Net Id	Size
S3.2.1	Analog Inputs					
S3.2.1.1	AI1	-100.00 to 100.00 %	2	3C95h	7317	s16bit
S3.2.1.2	AI2	-100.00 to 100.00 %	2	3C96h	7318	s16bit
S3.2.1.3	AI3	-100.00 to 100.00 %	2	3C97h	7319	s16bit
S3.2.2	Analog Outputs					
S3.2.2.1	AO1	-100.00 to 100.00 %	2	3CA3h	7331	s16bit
S3.2.2.2	AO1 Network	-100.00 to 100.00 %	2	3CA7h	7335	s16bit
S3.2.2.3	AO1 SoftPLC	-100.00 to 100.00 %	2	3CABh	7339	s16bit
S3.2.2.4	AO2	-100.00 to 100.00 %	2	3CA4h	7332	s16bit
S3.2.2.5	AO2 Network	-100.00 to 100.00 %	2	3CA8h	7336	s16bit
S3.2.2.6	AO2 SoftPLC	-100.00 to 100.00 %	2	3CACH	7340	s16bit
S3.2.3	Digital Inputs					
S3.2.3.1	DI	Bit 0 = DI1 Bit 1 = DI2 Bit 2 = DI3 Bit 3 = DI4 Bit 4 = DI5 Bit 5 = DI6 Bit 6 = DI7 Bit 7 = DI8		3C94h	7316	8bit
S3.2.4	Digital Outputs					
S3.2.4.1	DO	Bit 0 = DO1 Bit 1 = DO2 Bit 2 = DO3 Bit 3 = DO4 Bit 4 = DO5 Bit 5 = DO6 Bit 6 = DO7 Bit 7 = DO8		3C9Fh	7327	8bit
S3.2.4.2	DO Network	Bit 0 = DO1 Bit 1 = DO2 Bit 2 = DO3 Bit 3 = DO4 Bit 4 = DO5 Bit 5 = DO6 Bit 6 = DO7 Bit 7 = DO8		3CA0h	7328	8bit
S3.2.4.3	DO SoftPLC	Bit 0 = DO1 Bit 1 = DO2 Bit 2 = DO3 Bit 3 = DO4 Bit 4 = DO5 Bit 5 = DO6 Bit 6 = DO7 Bit 7 = DO8		3CA1h	7329	8bit

Parameter	Description	Range of values	Decimal places	Index	Net Id	Size
S3.2.5	Encoder					
S3.2.5.1	Number of Revolutions	0 to 65535	0	3C8Fh	7311	16bit
S3.2.5.2	Revolution Fraction	0 to 65535	0	3C90h	7312	16bit
S3.2.5.3	Speed	-60000 to 60000 rpm	0	3C92h	7314	s32bit
S3.2.5.4	Search Zero	0 = Inactive 1 = Completed		3C91h	7313	enum
S3.2.6	Temperatures					
S3.2.6.1	Sensor 1	-100.0 to 250.0 °C	1	3C99h	7321	s16bit
S3.2.6.2	Sensor 2	-100.0 to 250.0 °C	1	3C9Ah	7322	s16bit
S3.2.6.3	Sensor 3	-100.0 to 250.0 °C	1	3C9Bh	7323	s16bit
S3.2.6.4	Sensor 4	-100.0 to 250.0 °C	1	3C9Ch	7324	s16bit
S3.2.6.5	Sensor 5	-100.0 to 250.0 °C	1	3C9Dh	7325	s16bit
S3.2.6.6	Sensor 6	-100.0 to 250.0 °C	1	3C9Eh	7326	s16bit
S3.3	Slot B Status					
S3.3.1	Analog Inputs					
S3.3.1.1	AI1	-100.00 to 100.00 %	2	3DC1h	7617	s16bit
S3.3.1.2	AI2	-100.00 to 100.00 %	2	3DC2h	7618	s16bit
S3.3.1.3	AI3	-100.00 to 100.00 %	2	3DC3h	7619	s16bit
S3.3.2	Analog Outputs					
S3.3.2.1	AO1	-100.00 to 100.00 %	2	3DCFh	7631	s16bit
S3.3.2.2	AO1 Network	-100.00 to 100.00 %	2	3DD3h	7635	s16bit
S3.3.2.3	AO1 SoftPLC	-100.00 to 100.00 %	2	3DD7h	7639	s16bit
S3.3.2.4	AO2	-100.00 to 100.00 %	2	3DD0h	7632	s16bit
S3.3.2.5	AO2 Network	-100.00 to 100.00 %	2	3DD4h	7636	s16bit
S3.3.2.6	AO2 SoftPLC	-100.00 to 100.00 %	2	3DD8h	7640	s16bit
S3.3.3	Digital Inputs					
S3.3.3.1	DI	Bit 0 = DI1 Bit 1 = DI2 Bit 2 = DI3 Bit 3 = DI4 Bit 4 = DI5 Bit 5 = DI6 Bit 6 = DI7 Bit 7 = DI8		3DC0h	7616	8bit
S3.3.4	Digital Outputs					
S3.3.4.1	DO	Bit 0 = DO1 Bit 1 = DO2 Bit 2 = DO3 Bit 3 = DO4 Bit 4 = DO5 Bit 5 = DO6 Bit 6 = DO7 Bit 7 = DO8		3DCBh	7627	8bit
S3.3.4.2	DO Network	Bit 0 = DO1 Bit 1 = DO2		3DCCh	7628	8bit

Parameter	Description	Range of values	Decimal places	Index	Net Id	Size
		Bit 2 = DO3 Bit 3 = DO4 Bit 4 = DO5 Bit 5 = DO6 Bit 6 = DO7 Bit 7 = DO8				
S3.3.4.3	DO SoftPLC	Bit 0 = DO1 Bit 1 = DO2 Bit 2 = DO3 Bit 3 = DO4 Bit 4 = DO5 Bit 5 = DO6 Bit 6 = DO7 Bit 7 = DO8		3DCDh	7629	8bit
S3.3.5	Encoder					
S3.3.5.1	Number of Revolutions	0 to 65535	0	3DBBh	7611	16bit
S3.3.5.2	Revolution Fraction	0 to 65535	0	3DBCh	7612	16bit
S3.3.5.3	Speed	-60000 to 60000 rpm	0	3DBEh	7614	s32bit
S3.3.5.4	Search Zero	0 = Inactive 1 = Completed		3DBDh	7613	enum
S3.3.6	Temperatures					
S3.3.6.1	Sensor 1	-100.0 to 250.0 °C	1	3DC5h	7621	s16bit
S3.3.6.2	Sensor 2	-100.0 to 250.0 °C	1	3DC6h	7622	s16bit
S3.3.6.3	Sensor 3	-100.0 to 250.0 °C	1	3DC7h	7623	s16bit
S3.3.6.4	Sensor 4	-100.0 to 250.0 °C	1	3DC8h	7624	s16bit
S3.3.6.5	Sensor 5	-100.0 to 250.0 °C	1	3DC9h	7625	s16bit
S3.3.6.6	Sensor 6	-100.0 to 250.0 °C	1	3DCAh	7626	s16bit
S3.4	Slot C Status					
S3.4.1	Analog Inputs					
S3.4.1.1	AI1	-100.00 to 100.00 %	2	3EEDh	7917	s16bit
S3.4.1.2	AI2	-100.00 to 100.00 %	2	3EEHh	7918	s16bit
S3.4.1.3	AI3	-100.00 to 100.00 %	2	3EEFh	7919	s16bit
S3.4.2	Analog Outputs					
S3.4.2.1	AO1	-100.00 to 100.00 %	2	3EFBh	7931	s16bit
S3.4.2.2	AO1 Network	-100.00 to 100.00 %	2	3EFFh	7935	s16bit
S3.4.2.3	AO1 SoftPLC	-100.00 to 100.00 %	2	3F03h	7939	s16bit
S3.4.2.4	AO2	-100.00 to 100.00 %	2	3EFCh	7932	s16bit
S3.4.2.5	AO2 Network	-100.00 to 100.00 %	2	3F00h	7936	s16bit
S3.4.2.6	AO2 SoftPLC	-100.00 to 100.00 %	2	3F04h	7940	s16bit
S3.4.3	Digital Inputs					
S3.4.3.1	DI	Bit 0 = DI1 Bit 1 = DI2 Bit 2 = DI3 Bit 3 = DI4 Bit 4 = DI5 Bit 5 = DI6		3EECh	7916	8bit

Parameter	Description	Range of values	Decimal places	Index	Net Id	Size
		Bit 6 = DI7 Bit 7 = DI8				
S3.4.4	Digital Outputs					
S3.4.4.1	DO	Bit 0 = DO1 Bit 1 = DO2 Bit 2 = DO3 Bit 3 = DO4 Bit 4 = DO5 Bit 5 = DO6 Bit 6 = DO7 Bit 7 = DO8		3EF7h	7927	8bit
S3.4.4.2	DO Network	Bit 0 = DO1 Bit 1 = DO2 Bit 2 = DO3 Bit 3 = DO4 Bit 4 = DO5 Bit 5 = DO6 Bit 6 = DO7 Bit 7 = DO8		3EF8h	7928	8bit
S3.4.4.3	DO SoftPLC	Bit 0 = DO1 Bit 1 = DO2 Bit 2 = DO3 Bit 3 = DO4 Bit 4 = DO5 Bit 5 = DO6 Bit 6 = DO7 Bit 7 = DO8		3EF9h	7929	8bit
S3.4.5	Encoder					
S3.4.5.1	Number of Revolutions	0 to 65535	0	3EE7h	7911	16bit
S3.4.5.2	Revolution Fraction	0 to 65535	0	3EE8h	7912	16bit
S3.4.5.3	Speed	-60000 to 60000 rpm	0	3EEAh	7914	s32bit
S3.4.5.4	Search Zero	0 = Inactive 1 = Completed		3EE9h	7913	enum
S3.4.6	Temperatures					
S3.4.6.1	Sensor 1	-100.0 to 250.0 °C	1	3EF1h	7921	s16bit
S3.4.6.2	Sensor 2	-100.0 to 250.0 °C	1	3EF2h	7922	s16bit
S3.4.6.3	Sensor 3	-100.0 to 250.0 °C	1	3EF3h	7923	s16bit
S3.4.6.4	Sensor 4	-100.0 to 250.0 °C	1	3EF4h	7924	s16bit
S3.4.6.5	Sensor 5	-100.0 to 250.0 °C	1	3EF5h	7925	s16bit
S3.4.6.6	Sensor 6	-100.0 to 250.0 °C	1	3EF6h	7926	s16bit
S3.5	Slot D Status					
S3.5.1	Analog Inputs					
S3.5.1.1	AI1	-100.00 to 100.00 %	2	4019h	8217	s16bit
S3.5.1.2	AI2	-100.00 to 100.00 %	2	401Ah	8218	s16bit
S3.5.1.3	AI3	-100.00 to 100.00 %	2	401Bh	8219	s16bit

Parameter	Description	Range of values	Decimal places	Index	Net Id	Size
S3.5.2	Analog Outputs					
S3.5.2.1	AO1	-100.00 to 100.00 %	2	4027h	8231	s16bit
S3.5.2.2	AO1 Network	-100.00 to 100.00 %	2	402Bh	8235	s16bit
S3.5.2.3	AO1 SoftPLC	-100.00 to 100.00 %	2	402Fh	8239	s16bit
S3.5.2.4	AO2	-100.00 to 100.00 %	2	4028h	8232	s16bit
S3.5.2.5	AO2 Network	-100.00 to 100.00 %	2	402Ch	8236	s16bit
S3.5.2.6	AO2 SoftPLC	-100.00 to 100.00 %	2	4030h	8240	s16bit
S3.5.3	Digital Inputs					
S3.5.3.1	DI	Bit 0 = DI1 Bit 1 = DI2 Bit 2 = DI3 Bit 3 = DI4 Bit 4 = DI5 Bit 5 = DI6 Bit 6 = DI7 Bit 7 = DI8		4018h	8216	8bit
S3.5.4	Digital Outputs					
S3.5.4.1	DO	Bit 0 = DO1 Bit 1 = DO2 Bit 2 = DO3 Bit 3 = DO4 Bit 4 = DO5 Bit 5 = DO6 Bit 6 = DO7 Bit 7 = DO8		4023h	8227	8bit
S3.5.4.2	DO Network	Bit 0 = DO1 Bit 1 = DO2 Bit 2 = DO3 Bit 3 = DO4 Bit 4 = DO5 Bit 5 = DO6 Bit 6 = DO7 Bit 7 = DO8		4024h	8228	8bit
S3.5.4.3	DO SoftPLC	Bit 0 = DO1 Bit 1 = DO2 Bit 2 = DO3 Bit 3 = DO4 Bit 4 = DO5 Bit 5 = DO6 Bit 6 = DO7 Bit 7 = DO8		4025h	8229	8bit
S3.5.5	Encoder					
S3.5.5.1	Number of Revolutions	0 to 65535	0	4013h	8211	16bit
S3.5.5.2	Revolution Fraction	0 to 65535	0	4014h	8212	16bit
S3.5.5.3	Speed	-60000 to 60000 rpm	0	4016h	8214	s32bit

Parameter	Description	Range of values	Decimal places	Index	Net Id	Size
S3.5.5.4	Search Zero	0 = Inactive 1 = Completed		4015h	8213	enum
S3.5.6	Temperatures					
S3.5.6.1	Sensor 1	-100.0 to 250.0 °C	1	401Dh	8221	s16bit
S3.5.6.2	Sensor 2	-100.0 to 250.0 °C	1	401Eh	8222	s16bit
S3.5.6.3	Sensor 3	-100.0 to 250.0 °C	1	401Fh	8223	s16bit
S3.5.6.4	Sensor 4	-100.0 to 250.0 °C	1	4020h	8224	s16bit
S3.5.6.5	Sensor 5	-100.0 to 250.0 °C	1	4021h	8225	s16bit
S3.5.6.6	Sensor 6	-100.0 to 250.0 °C	1	4022h	8226	s16bit
S3.6	Slot E Status					
S3.6.1	Analog Inputs					
S3.6.1.1	AI1	-100.00 to 100.00 %	2	4145h	8517	s16bit
S3.6.1.2	AI2	-100.00 to 100.00 %	2	4146h	8518	s16bit
S3.6.1.3	AI3	-100.00 to 100.00 %	2	4147h	8519	s16bit
S3.6.2	Analog Outputs					
S3.6.2.1	AO1	-100.00 to 100.00 %	2	4153h	8531	s16bit
S3.6.2.2	AO1 Network	-100.00 to 100.00 %	2	4157h	8535	s16bit
S3.6.2.3	AO1 SoftPLC	-100.00 to 100.00 %	2	415Bh	8539	s16bit
S3.6.2.4	AO2	-100.00 to 100.00 %	2	4154h	8532	s16bit
S3.6.2.5	AO2 Network	-100.00 to 100.00 %	2	4158h	8536	s16bit
S3.6.2.6	AO2 SoftPLC	-100.00 to 100.00 %	2	415Ch	8540	s16bit
S3.6.3	Digital Inputs					
S3.6.3.1	DI	Bit 0 = DI1 Bit 1 = DI2 Bit 2 = DI3 Bit 3 = DI4 Bit 4 = DI5 Bit 5 = DI6 Bit 6 = DI7 Bit 7 = DI8		4144h	8516	8bit
S3.6.4	Digital Outputs					
S3.6.4.1	DO	Bit 0 = DO1 Bit 1 = DO2 Bit 2 = DO3 Bit 3 = DO4 Bit 4 = DO5 Bit 5 = DO6 Bit 6 = DO7 Bit 7 = DO8		414Fh	8527	8bit
S3.6.4.2	DO Network	Bit 0 = DO1 Bit 1 = DO2 Bit 2 = DO3 Bit 3 = DO4 Bit 4 = DO5 Bit 5 = DO6		4150h	8528	8bit

Parameter	Description	Range of values	Decimal places	Index	Net Id	Size
S3.6.4.3	DO SoftPLC	Bit 6 = DO7 Bit 7 = DO8 Bit 0 = DO1 Bit 1 = DO2 Bit 2 = DO3 Bit 3 = DO4 Bit 4 = DO5 Bit 5 = DO6 Bit 6 = DO7 Bit 7 = DO8		4151h	8529	8bit
S3.6.5	Encoder					
S3.6.5.1	Number of Revolutions	0 to 65535	0	413Fh	8511	16bit
S3.6.5.2	Revolution Fraction	0 to 65535	0	4140h	8512	16bit
S3.6.5.3	Speed	-60000 to 60000 rpm	0	4142h	8514	s32bit
S3.6.5.4	Search Zero	0 = Inactive 1 = Completed		4141h	8513	enum
S3.6.6	Temperatures					
S3.6.6.1	Sensor 1	-100.0 to 250.0 °C	1	4149h	8521	s16bit
S3.6.6.2	Sensor 2	-100.0 to 250.0 °C	1	414Ah	8522	s16bit
S3.6.6.3	Sensor 3	-100.0 to 250.0 °C	1	414Bh	8523	s16bit
S3.6.6.4	Sensor 4	-100.0 to 250.0 °C	1	414Ch	8524	s16bit
S3.6.6.5	Sensor 5	-100.0 to 250.0 °C	1	414Dh	8525	s16bit
S3.6.6.6	Sensor 6	-100.0 to 250.0 °C	1	414Eh	8526	s16bit
S3.7	Slot F Status					
S3.7.1	Analog Inputs					
S3.7.1.1	AI1	-100.00 to 100.00 %	2	4271h	8817	s16bit
S3.7.1.2	AI2	-100.00 to 100.00 %	2	4272h	8818	s16bit
S3.7.1.3	AI3	-100.00 to 100.00 %	2	4273h	8819	s16bit
S3.7.2	Analog Outputs					
S3.7.2.1	AO1	-100.00 to 100.00 %	2	427Fh	8831	s16bit
S3.7.2.2	AO1 Network	-100.00 to 100.00 %	2	4283h	8835	s16bit
S3.7.2.3	AO1 SoftPLC	-100.00 to 100.00 %	2	4287h	8839	s16bit
S3.7.2.4	AO2	-100.00 to 100.00 %	2	4280h	8832	s16bit
S3.7.2.5	AO2 Network	-100.00 to 100.00 %	2	4284h	8836	s16bit
S3.7.2.6	AO2 SoftPLC	-100.00 to 100.00 %	2	4288h	8840	s16bit
S3.7.3	Digital Inputs					
S3.7.3.1	DI	Bit 0 = DI1 Bit 1 = DI2 Bit 2 = DI3 Bit 3 = DI4 Bit 4 = DI5 Bit 5 = DI6 Bit 6 = DI7 Bit 7 = DI8		4270h	8816	8bit
S3.7.4	Digital Outputs					
S3.7.4.1	DO			427Bh	8827	8bit

Parameter	Description	Range of values	Decimal places	Index	Net Id	Size
		Bit 0 = DO1 Bit 1 = DO2 Bit 2 = DO3 Bit 3 = DO4 Bit 4 = DO5 Bit 5 = DO6 Bit 6 = DO7 Bit 7 = DO8				
S3.7.4.2	DO Network	Bit 0 = DO1 Bit 1 = DO2 Bit 2 = DO3 Bit 3 = DO4 Bit 4 = DO5 Bit 5 = DO6 Bit 6 = DO7 Bit 7 = DO8		427Ch	8828	8bit
S3.7.4.3	DO SoftPLC	Bit 0 = DO1 Bit 1 = DO2 Bit 2 = DO3 Bit 3 = DO4 Bit 4 = DO5 Bit 5 = DO6 Bit 6 = DO7 Bit 7 = DO8		427Dh	8829	8bit
S3.7.5	Encoder					
S3.7.5.1	Number of Revolutions	0 to 65535	0	426Bh	8811	16bit
S3.7.5.2	Revolution Fraction	0 to 65535	0	426Ch	8812	16bit
S3.7.5.3	Speed	-60000 to 60000 rpm	0	426Eh	8814	s32bit
S3.7.5.4	Search Zero	0 = Inactive 1 = Completed		426Dh	8813	enum
S3.7.6	Temperatures					
S3.7.6.1	Sensor 1	-100.0 to 250.0 °C	1	4275h	8821	s16bit
S3.7.6.2	Sensor 2	-100.0 to 250.0 °C	1	4276h	8822	s16bit
S3.7.6.3	Sensor 3	-100.0 to 250.0 °C	1	4277h	8823	s16bit
S3.7.6.4	Sensor 4	-100.0 to 250.0 °C	1	4278h	8824	s16bit
S3.7.6.5	Sensor 5	-100.0 to 250.0 °C	1	4279h	8825	s16bit
S3.7.6.6	Sensor 6	-100.0 to 250.0 °C	1	427Ah	8826	s16bit
S3.8	Slot G Status					
S3.8.1	Analog Inputs					
S3.8.1.1	AI1	-100.00 to 100.00 %	2	439Dh	9117	s16bit
S3.8.1.2	AI2	-100.00 to 100.00 %	2	439Eh	9118	s16bit
S3.8.1.3	AI3	-100.00 to 100.00 %	2	439Fh	9119	s16bit
S3.8.2	Analog Outputs					
S3.8.2.1	AO1	-100.00 to 100.00 %	2	43ABh	9131	s16bit
S3.8.2.2	AO1 Network	-100.00 to 100.00 %	2	43AFh	9135	s16bit
S3.8.2.3	AO1 SoftPLC	-100.00 to 100.00 %	2	43B3h	9139	s16bit

Parameter	Description	Range of values	Decimal places	Index	Net Id	Size
S3.8.2.4	AO2	-100.00 to 100.00 %	2	43ACh	9132	s16bit
S3.8.2.5	AO2 Network	-100.00 to 100.00 %	2	43B0h	9136	s16bit
S3.8.2.6	AO2 SoftPLC	-100.00 to 100.00 %	2	43B4h	9140	s16bit
S3.8.3	Digital Inputs					
S3.8.3.1	DI	Bit 0 = DI1 Bit 1 = DI2 Bit 2 = DI3 Bit 3 = DI4 Bit 4 = DI5 Bit 5 = DI6 Bit 6 = DI7 Bit 7 = DI8		439Ch	9116	8bit
S3.8.4	Digital Outputs					
S3.8.4.1	DO	Bit 0 = DO1 Bit 1 = DO2 Bit 2 = DO3 Bit 3 = DO4 Bit 4 = DO5 Bit 5 = DO6 Bit 6 = DO7 Bit 7 = DO8		43A7h	9127	8bit
S3.8.4.2	DO Network	Bit 0 = DO1 Bit 1 = DO2 Bit 2 = DO3 Bit 3 = DO4 Bit 4 = DO5 Bit 5 = DO6 Bit 6 = DO7 Bit 7 = DO8		43A8h	9128	8bit
S3.8.4.3	DO SoftPLC	Bit 0 = DO1 Bit 1 = DO2 Bit 2 = DO3 Bit 3 = DO4 Bit 4 = DO5 Bit 5 = DO6 Bit 6 = DO7 Bit 7 = DO8		43A9h	9129	8bit
S3.8.5	Encoder					
S3.8.5.1	Number of Revolutions	0 to 65535	0	4397h	9111	16bit
S3.8.5.2	Revolution Fraction	0 to 65535	0	4398h	9112	16bit
S3.8.5.3	Speed	-60000 to 60000 rpm	0	439Ah	9114	s32bit
S3.8.5.4	Search Zero	0 = Inactive 1 = Completed		4399h	9113	enum
S3.8.6	Temperatures					

Parameter	Description	Range of values	Decimal places	Index	Net Id	Size
S3.8.6.1	Sensor 1	-100.0 to 250.0 °C	1	43A1h	9121	s16bit
S3.8.6.2	Sensor 2	-100.0 to 250.0 °C	1	43A2h	9122	s16bit
S3.8.6.3	Sensor 3	-100.0 to 250.0 °C	1	43A3h	9123	s16bit
S3.8.6.4	Sensor 4	-100.0 to 250.0 °C	1	43A4h	9124	s16bit
S3.8.6.5	Sensor 5	-100.0 to 250.0 °C	1	43A5h	9125	s16bit
S3.8.6.6	Sensor 6	-100.0 to 250.0 °C	1	43A6h	9126	s16bit
S4 Status\Functional Safety						
S4.1	Status	0 = Not used 1 = STO 2 = Operational 3 = Programming 4 = SS1-t 5 = Fault		205Ah	90	enum
S4.2	SS1-t Delay Time	0 to 999 s	0	205Ch	92	16bit
S5 Status\Communications						
S5.1	Status and Commands					
S5.1.1	Status Word 1	Bit 0 = STO Bit 1 = Run Command Bit 2 = Local Bit 3 = Not used Bit 4 = No Quick Stop Bit 5 = 2nd Ramp Bit 6 = Config. Mode Bit 7 = Alarm Bit 8 = Running Bit 9 = Enabled Bit 10 = Reverse Bit 11 = JOG Bit 12 = Remote 2 Bit 13 = Undervoltage Bit 14 = Not used Bit 15 = Fault		22A8h	680	16bit
S5.1.2	Speed	-200.00 to 200.00 %	2	22A9h	681	s16bit
S5.1.3	Status Word 2	Bit 0 = Self-tuning Bit 1 = Not used Bit 2 = Pre-Charge OK Bit 3 ... 4 = Not used Bit 5 = Decel. Ramp Bit 6 = Acc. Ramp Bit 7 = Freeze Ramp Bit 8 = Setpoint OK Bit 9 = DC Voltage Limitation Bit 10 = Current Limitation Bit 11 = Torque Limitation Bit 12 = Ride-Through Bit 13 = Flying Start Bit 14 = DC Braking		22B2h	690	16bit

Parameter	Description	Range of values	Decimal places	Index	Net Id	Size
S5.1.4	Status Word 3	Bit 15 = PWM pulses Bit 0 = SD Card Bit 1 = Not used		22B3h	691	2bit
S5.2	Serial RS485					
S5.2.1	Interface Status	0 = Inactive 1 = Active 2 = Timeout Error		22DFh	735	enum
S5.2.2	Control Word	Bit 0 = Enable Ramp Bit 1 = General Enable Bit 2 = Run Reverse Bit 3 = Enable JOG Bit 4 = R1/R2 Mode Bit 5 = 2nd Ramp Bit 6 = No Quick Stop Bit 7 = Fault Reset		22AAh	682	8bit
S5.2.3	Speed Reference	-200.00 to 200.00 %	2	22ABh	683	s16bit
S5.2.5	Received Telegrams	0 to 65535	0	22E0h	736	16bit
S5.2.6	Transmitted Telegrams	0 to 65535	0	22E1h	737	16bit
S5.2.7	Telegramms with Error	0 to 65535	0	22E2h	738	16bit
S5.2.8	Reception Errors	0 to 65535	0	22E3h	739	16bit
S5.3	Ethernet					
S5.3.1	Interface Status	Bit 0 = Link 1 Bit 1 = Link 2		237Ah	890	2bit
S5.3.2	Control Word	Bit 0 = Enable Ramp Bit 1 = General Enable Bit 2 = Run Reverse Bit 3 = Enable JOG Bit 4 = R1/R2 Mode Bit 5 = 2nd Ramp Bit 6 = No Quick Stop Bit 7 = Fault Reset		2298h	664	8bit
S5.3.3	Speed Reference	-200.00 to 200.00 %	2	2299h	665	s16bit
S5.3.5	Actual IP Address	0.0.0.0 to 255.255.255.255		234Eh	846	STRING
S5.3.6	MQTT Status	0 = Inactive 1 = No Connection 2 = Connected		2349h	841	enum
S5.3.7	Last Public. MQTT	0 to 2147483647	0	234Ah	842	NONE
S5.3.8	SNTP - Status	0 = Inactive 1 = No Connection 2 = Connected		230Ah	778	enum
S5.3.9	SNTP - Last update	0 to 2147483647	0	230Ch	780	NONE
S5.3.10	SymbiNet: Groups Status			242Bh	1067	8bit

Parameter	Description	Range of values	Decimal places	Index	Net Id	Size
		Bit 0 = Group 1 Status Bit 1 = Group 2 Status Bit 2 = Group 3 Status Bit 3 = Group 4 Status Bit 4 = Group 5 Status Bit 5 = Group 6 Status Bit 6 = Group 7 Status Bit 7 = Group 8 Status				
S5.4	EtherNet/IP					
S5.4.1	EIP Master Status	0 = Run 1 = Idle		2365h	869	enum
S5.4.2	Communication Status	0 = Inactive 1 = No Connection 2 = Connected 3 = I/O Connection Timeout 4 = Duplicate IP		2366h	870	enum
S5.4.3	DLR Topology	0 = Linear 1 = Ring		236Ch	876	enum
S5.4.4	DLR Status	0 = Idle State 1 = Normal State 2 = Fault State		236Dh	877	enum
S5.5	Modbus TCP					
S5.5.1	Communication Status	0 = Inactive 1 = No Connection 2 = Connected 3 = Timeout Error		235Ch	860	enum
S5.5.2	Received Telegrams	0 to 65535	0	235Dh	861	16bit
S5.5.3	Transmitted Telegrams	0 to 65535	0	235Eh	862	16bit
S5.5.4	Active Connections	0 to 4	0	235Fh	863	16bit
S5.6	Anybus					
S5.6.1	Identification	0 = Inactive 1 = PROFIBUS DP-V1 2 = EtherCAT 3 = PROFINET IRT 4 ... 5 = Not used		22EEh	750	enum
S5.6.2	Communication Status	0 = Inactive 1 = Not Supported 2 = Access Error 3 = Offline 4 = Online		22EFh	751	enum
S5.6.3	Control Word	Bit 0 = Enable Ramp		2294h	660	8bit

Parameter	Description	Range of values	Decimal places	Index	Net Id	Size
S5.6.4	Speed Reference	Bit 1 = General Enable Bit 2 = Run Reverse Bit 3 = Enable JOG Bit 4 = R1/R2 Mode Bit 5 = 2nd Ramp Bit 6 = No Quick Stop Bit 7 = Fault Reset -200.00 to 200.00 %	2	2295h	661	s16bit
S5.7	CAN/CANopen/DNet					
S5.7.1	CAN Controller Status	0 = Inactive 1 = Auto-Baud 2 = CAN Active 3 = Warning 4 = Error Passive 5 = Bus Off 6 = No Bus Power		22C1h	705	enum
S5.7.2	Control Word	Bit 0 = Enable Ramp Bit 1 = General Enable Bit 2 = Run Reverse Bit 3 = Enable JOG Bit 4 = R1/R2 Mode Bit 5 = 2nd Ramp Bit 6 = No Quick Stop Bit 7 = Fault Reset		22ACh	684	8bit
S5.7.3	Speed Reference	-200.00 to 200.00 %	2	22ADh	685	s16bit
S5.7.5	Received Telegrams	0 to 65535	0	22C2h	706	16bit
S5.7.6	Transmitted Telegrams	0 to 65535	0	22C3h	707	16bit
S5.7.7	Bus Off Counter	0 to 65535	0	22C4h	708	16bit
S5.7.8	Lost Messages	0 to 65535	0	22C5h	709	16bit
S5.7.9	CANopen Comm. Status	0 = Inactive 1 = Not used 2 = Comm. Enabled 3 = Error Ctrl. Enab. 4 = Guarding Error 5 = Heartbeat Error		22D1h	721	enum
S5.7.10	CANopen Node Status	0 = Inactive 1 = Initialization 2 = Stopped 3 = Operational 4 = Pre-Operational		22D2h	722	enum
S5.7.11	DNet Network Status	0 = Offline 1 = Online Not Connec. 2 = Online, Connected 3 = Connection Timed Out 4 = Link Failure		22CCh	716	enum

Parameter	Description	Range of values	Decimal places	Index	Net Id	Size
S5.7.12	DNet Master Status	5 = Auto-Baud 0 = Run 1 = Idle		22CDh	717	enum
S5.9 S5.9.1	Bluetooth MAC Address	00:00:00:00:00:00 to FF:FF:FF:FF:FF:FF		2321h	801	NONE
S6 Status\SoftPLC						
S6.1	Program Execution					
S6.1.1	Status	0 = No Program 1 = Saving Program 2 = Invalid Program 3 = Program Stopped 4 = Program Running		3388h	5000	enum
S6.1.2	Time	0 to 65535 ms	0	3389h	5001	16bit
S6.2	Control and References					
S6.2.1	Control Word	Bit 0 = Enable Ramp Bit 1 = General Enable Bit 2 = Run Reverse Bit 3 = Enable JOG Bit 4 = R1/R2 Mode Bit 5 = 2nd Ramp Bit 6 = No Quick Stop Bit 7 = Fault Reset		33F6h	5110	8bit
S6.2.3	Speed Reference	-200.00 to 200.00 %	2	33F8h	5112	s16bit
S7 Status\User						
S7.1	Login Active	0 = Administrator 1 = Operator 2 ... 5 = Not used		20C7h	199	enum
D1 Diagnostics\Faults						
D1.1	Actual					
D1.1.1	Fault 1	0 to 1999	0	203Ch	60	16bit
D1.1.2	Fault 2	0 to 1999	0	203Dh	61	16bit
D1.1.3	Fault 3	0 to 1999	0	203Eh	62	16bit
D1.1.4	Fault 4	0 to 1999	0	203Fh	63	16bit
D1.1.5	Fault 5	0 to 1999	0	2040h	64	16bit
D1.2	History					
D1.3	Simplified History					
D1.3.1	Last Fault	0 to 9999	0	3004h	4100	16bit
D1.3.2	Date and Time Last Fault	0 to 2147483647	0	3006h	4102	NONE
D1.3.3	Second Fault	0 to 9999	0	3008h	4104	16bit
D1.3.4	Date and Time Second Fault	0 to 2147483647	0	300Ah	4106	NONE
D1.3.5	Third Fault	0 to 9999	0	300Ch	4108	16bit
D1.3.6	Date and Time Third Fault	0 to 2147483647	0	300Eh	4110	NONE
D1.3.7	Fourth Fault	0 to 9999	0	3010h	4112	16bit



Parameter	Description	Range of values	Decimal places	Index	Net Id	Size
D1.3.8	Date and Time Fourth Fault	0 to 2147483647	0	3012h	4114	NONE
D1.3.9	Fifth Fault	0 to 9999	0	3014h	4116	16bit
D1.3.10	Date and Time Fifth Fault	0 to 2147483647	0	3016h	4118	NONE
D1.3.11	Sixth Fault	0 to 9999	0	3018h	4120	16bit
D1.3.12	Date and Time Sixth Fault	0 to 2147483647	0	301Ah	4122	NONE
D1.3.13	Seventh Fault	0 to 9999	0	301Ch	4124	16bit
D1.3.14	Date and Time Seventh Fault	0 to 2147483647	0	301Eh	4126	NONE
D1.3.15	Eighth Fault	0 to 9999	0	3020h	4128	16bit
D1.3.16	Date and Time Eighth Fault	0 to 2147483647	0	3022h	4130	NONE
D1.3.17	Ninth Fault	0 to 9999	0	3024h	4132	16bit
D1.3.18	Date and Time Ninth Fault	0 to 2147483647	0	3026h	4134	NONE
D1.3.19	Tenth Fault	0 to 9999	0	3028h	4136	16bit
D1.3.20	Date and Time Tenth Fault	0 to 2147483647	0	302Ah	4138	NONE
D2 Diagnostics\Alarms						
D2.1	Actual					
D2.1.1	Alarm 1	0 to 1999	0	2032h	50	16bit
D2.1.2	Alarm 2	0 to 1999	0	2033h	51	16bit
D2.1.3	Alarm 3	0 to 1999	0	2034h	52	16bit
D2.1.4	Alarm 4	0 to 1999	0	2035h	53	16bit
D2.1.5	Alarm 5	0 to 1999	0	2036h	54	16bit
D2.2	History					
D2.3	Simplified History					
D2.3.1	Last Alarm	0 to 9999	0	3036h	4150	16bit
D2.3.2	Date and Time Last Alarm	0 to 2147483647	0	3038h	4152	NONE
D2.3.3	Second Alarm	0 to 9999	0	303Ah	4154	16bit
D2.3.4	Date and Time Second Alarm	0 to 2147483647	0	303Ch	4156	NONE
D2.3.5	Third Alarm	0 to 9999	0	303Eh	4158	16bit
D2.3.6	Date and Time Third Alarm	0 to 2147483647	0	3040h	4160	NONE
D2.3.7	Fourth Alarm	0 to 9999	0	3042h	4162	16bit
D2.3.8	Date and Time Fourth Alarm	0 to 2147483647	0	3044h	4164	NONE
D2.3.9	Fifth Alarm	0 to 9999	0	3046h	4166	16bit
D2.3.10	Date and Time Fifth Alarm	0 to 2147483647	0	3048h	4168	NONE
D2.3.11	Sixth Alarm	0 to 9999	0	304Ah	4170	16bit
D2.3.12	Date and Time Sixth Alarm	0 to 2147483647	0	304Ch	4172	NONE
D2.3.13	Seventh Alarm	0 to 9999	0	304Eh	4174	16bit
D2.3.14	Date and Time Seventh Alarm	0 to 2147483647	0	3050h	4176	NONE
D2.3.15	Eighth Alarm	0 to 9999	0	3052h	4178	16bit
D2.3.16	Date and Time Eighth Alarm	0 to 2147483647	0	3054h	4180	NONE
D2.3.17	Ninth Alarm	0 to 9999	0	3056h	4182	16bit
D2.3.18	Date and Time Ninth Alarm	0 to 2147483647	0	3058h	4184	NONE
D2.3.19	Tenth Alarm	0 to 9999	0	305Ah	4186	16bit
D2.3.20	Date and Time Tenth Alarm	0 to 2147483647	0	305Ch	4188	NONE
D3 Diagnostics\Hour Control						
D3.1	Time Powered	0 to 65536 h	0	202Ah	42	NONE
D3.2	Hours Enabled	0 to 65536 h	0	202Ch	44	NONE
D3.3	Fan Running Hours	0 to 65536 h	0	202Eh	46	NONE
D4 Diagnostics\Inverter and Control Access.						
D4.1	Inverter					
D4.1.1	Fan Speed					

Parameter	Description	Range of values	Decimal places	Index	Net Id	Size
D4.1.1.1	Power Fan 1 Speed	0 to 30000 rpm	0	27DEh	2014	16bit
D4.1.1.2	Power Fan 2 Speed	0 to 30000 rpm	0	27DFh	2015	16bit
D4.1.1.3	Power Fan 3 Speed	0 to 30000 rpm	0	27E0h	2016	16bit
D4.1.1.4	Power Fan 4 Speed	0 to 30000 rpm	0	27E1h	2017	16bit
D4.1.1.5	Int. Fan 1 Speed	0 to 30000 rpm	0	27E2h	2018	16bit
D4.1.1.6	Int. Fan 2 Speed	0 to 30000 rpm	0	27E3h	2019	16bit
D4.1.2	Temperatures					
D4.1.2.2	Control Temperature 2	-50.0 to 250.0 °C	1	23DFh	991	s16bit
D4.1.2.3	Control Temperature 3	-50.0 to 250.0 °C	1	23E0h	992	s16bit
D4.1.2.4	Power Temp. 2	-50.0 to 250.0 °C	1	27EEh	2030	s16bit
D4.1.3	DC Link					
D4.1.3.1	100 Hz Harmonic	0.0 to 999.9 V	1	2270h	624	16bit
D4.1.3.2	120 Hz Harmonic	0.0 to 999.9 V	1	2271h	625	16bit
D4.1.4	Control Voltages					
D4.1.4.1	Voltage 24V IO	0.00 to 655.35 V	2	23ECh	1004	16bit
D4.1.4.2	Battery Voltage	0.00 to 655.35 V	2	23EBh	1003	16bit
D4.1.4.3	Voltage 3.3V Control	0.00 to 655.35 V	2	23EDh	1005	16bit
D4.1.4.4	Voltage 24V Control	0.00 to 655.35 V	2	23EEh	1006	16bit
D4.1.4.5	Voltage 3.3V IO	0.00 to 655.35 V	2	23EFh	1007	16bit
D4.1.4.6	Voltage 5V AUI	0.00 to 655.35 V	2	23EAh	1002	16bit
D4.1.5	Motor Overl. Fault					
D4.1.5.1	Ixt Motor Level	0 to 100 %	0	2025h	37	16bit
D4.1.6	Thermal Management					
D4.1.6.1	IGBT Overload Status	0 = No Overload 1 = Slow Curve Overload 2 = Fast Curve 1 Overload 3 = Fast Curve 2 Overload		24B0h	1200	enum
D4.1.6.2	IGBT Overload Counter	0.00 to 100.00 %	2	24B1h	1201	16bit
D4.1.6.3	Heat Sink Temp.	0.00 to 655.35 °C	2	2BF7h	3063	16bit
D4.1.6.4	IGBT Junction Temp.	0.00 to 655.35 °C	2	2BF6h	3062	16bit
D4.1.6.5	Diode Junction Temp.	0.00 to 655.35 °C	2	2BFAh	3066	16bit
D4.2	Control Accessories					
D4.2.1	Diag. Slot A					
D4.2.1.1	Status	0 = Not Connected 1 = Initializing 2 = Active 3 = Error		3CE8h	7400	enum
D4.2.1.2	Error Cause	0 = No Error 1 ... 2 = Not used 3 = Initialization Error 4 ... 5 = Not used 6 = Disconnected 7 = Data Error 1 8 = Not used		3CE9h	7401	enum
D4.2.1.3	Temperature	-100.0 to 250.0 °C	1	3CEEh	7406	s16bit

Parameter	Description	Range of values	Decimal places	Index	Net Id	Size
D4.2.2	Diag. Slot B					
D4.2.2.1	Status	0 = Not Connected 1 = Initializing 2 = Active 3 = Error		3E14h	7700	enum
D4.2.2.2	Error Cause	0 = No Error 1 ... 2 = Not used 3 = Initialization Error 4 ... 5 = Not used 6 = Disconnected 7 = Data Error 1 8 = Not used		3E15h	7701	enum
D4.2.2.3	Temperature	-100.0 to 250.0 °C	1	3E1Ah	7706	s16bit
D4.2.3	Diag. Slot C					
D4.2.3.1	Status	0 = Not Connected 1 = Initializing 2 = Active 3 = Error		3F40h	8000	enum
D4.2.3.2	Error Cause	0 = No Error 1 ... 2 = Not used 3 = Initialization Error 4 ... 5 = Not used 6 = Disconnected 7 = Data Error 1 8 = Not used		3F41h	8001	enum
D4.2.3.3	Temperature	-100.0 to 250.0 °C	1	3F46h	8006	s16bit
D4.2.4	Diag. Slot D					
D4.2.4.1	Status	0 = Not Connected 1 = Initializing 2 = Active 3 = Error		406Ch	8300	enum
D4.2.4.2	Error Cause	0 = No Error 1 ... 2 = Not used 3 = Initialization Error 4 ... 5 = Not used 6 = Disconnected 7 = Data Error 1 8 = Not used		406Dh	8301	enum
D4.2.4.3	Temperature	-100.0 to 250.0 °C	1	4072h	8306	s16bit
D4.2.5	Diag. Slot E					
D4.2.5.1	Status	0 = Not Connected 1 = Initializing		4198h	8600	enum

Parameter	Description	Range of values	Decimal places	Index	Net Id	Size
D4.2.5.2	Error Cause	2 = Active 3 = Error		4199h	8601	enum
D4.2.5.3	Temperature	0 = No Error 1 ... 2 = Not used 3 = Initialization Error 4 ... 5 = Not used 6 = Disconnected 7 = Data Error 1 8 = Not used -100.0 to 250.0 °C	1	419Eh	8606	s16bit
D4.2.6	Diag. Slot F					
D4.2.6.1	Status	0 = Not Connected 1 = Initializing 2 = Active 3 = Error		42C4h	8900	enum
D4.2.6.2	Error Cause	0 = No Error 1 ... 2 = Not used 3 = Initialization Error 4 ... 5 = Not used 6 = Disconnected 7 = Data Error 1 8 = Not used		42C5h	8901	enum
D4.2.6.3	Temperature	-100.0 to 250.0 °C	1	42CAh	8906	s16bit
D4.2.7	Diag. Slot G					
D4.2.7.1	Status	0 = Not Connected 1 = Initializing 2 = Active 3 = Error		43F0h	9200	enum
D4.2.7.2	Error Cause	0 = No Error 1 ... 2 = Not used 3 = Initialization Error 4 ... 5 = Not used 6 = Disconnected 7 = Data Error 1 8 = Not used		43F1h	9201	enum
D4.2.7.3	Temperature	-100.0 to 250.0 °C	1	43F6h	9206	s16bit
D5 Diagnostics\Changed Parameters						
D5.1	Configurations					
D5.2	Application					
C1 Configurations\Inverter and Power Supply						
C1.1	Power Supply					
C1.1.1	Type	0 = Three-phase AC		250Eh	1294	enum

Parameter	Description	Range of values	Decimal places	Index	Net Id	Size
C1.1.2	Rated Voltage	1 = Single-phase AC 2 = DC 1 to 1200 V	0	2510h	1296	16bit
C1.2	Inverter Use					
C1.2.1	Overload Type	0 = Normal Duty (ND) 1 = Heavy Duty (HD)		2512h	1298	enum
C1.3	Switching Frequency					
C1.3.1	User	1.0 to 16.0 kHz	1	2511h	1297	16bit
C1.3.2	Minimum	1.00 to 16.00 kHz	2	2BDEh	3038	16bit
C1.4	PWM Modulation					
C1.4.1	Type	0 = SVM 1 = ePWM 2 = Long Cable Modulation		2FA0h	4000	enum
C1.4.4	PMW Wid. Adj. Long Cab.	0.00 to 1.00	2	2BF5h	3061	16bit
C1.4.5	Dead Time Compensation	0 = Disable 1 = Enable		2164h	356	enum
C1.5	Fans Configuration					
C1.5.1	Power Fan Setting	0 = Off 1 = On 2 = Temp. Control w/ Init.Test 3 = Control by Temperature		27D0h	2000	enum
C1.5.2	Internal Fan Setting	0 = Off 1 = On 2 = Temp. Control w/ Init.Test 3 = Control by Temperature		27D1h	2001	enum
C1.6	Other Inverter Settings					
C1.6.1	Invert Output Phase Seq.	0 = U(T1)/V(T2)/W(T3) 1 = W(T3)/V(T2)/U(T1)		2BF4h	3060	enum
C1.6.2	Reset Counters	0 = Disabled 1 = Energy 2 = Fan On 3 = Inverter Enabled		2BE7h	3047	enum
C1.6.3	User Temp. Delta	0.0 to 100.0 °C	1	250Dh	1293	s16bit
C1.6.4	Manual Inom Derating	0.0 to 100.0 %	1	250Ch	1292	16bit
C2 Configurations\Motor						
C2.1	Motor Data					
C2.1.1	Motor Type	0 = Induction 1 = Synchronous - IPSM 2 = Synchronous - SPSM 3 = Synchronous - HSRM		20CDh	205	enum

Parameter	Description	Range of values	Decimal places	Index	Net Id	Size
C2.1.2	Motor Power Unit	4 = Not used 0 = HP/cv 1 = kW		2195h	405	enum
C2.1.3	Rated Power	0.0 to 2000.0	1	2194h	404	16bit
C2.1.4	Rated Voltage	1 to 690 V	0	2190h	400	16bit
C2.1.5	Rated Current	0.0 to 2223.0 A	1	2191h	401	16bit
C2.1.6	Rated Frequency	1 to 500 Hz	0	2193h	403	16bit
C2.1.7	Number of Pole Pairs	1 to 90	0	21AFh	431	16bit
C2.1.8	Rated Speed	0 to 30000 rpm	0	2192h	402	16bit
C2.1.9	Rated Efficiency	50.0 to 99.9 %	1	218Fh	399	16bit
C2.1.10	Rated cos phi	0.50 to 0.99	2	2197h	407	16bit
C2.1.11	Service Factor	1.00 to 1.50	2	218Eh	398	16bit
C2.1.12	Ventilation	0 = Self-ventilated 1 = Independent		2196h	406	enum
C2.2	Motor Model Parameters					
C2.2.1	Stator Resistance	0.000 to 30.000 Ω	3	2199h	409	16bit
C2.2.2	Magnetizing Reactance	0.0 to 800.0 Ω	1	219Ah	410	16bit
C2.2.3	Leakage Reactance	0.00 to 100.00 Ω	2	219Bh	411	16bit
C2.2.4	Rotor Resistance	0.000 to 30.000 Ω	3	219Ch	412	16bit
C2.2.5	Rotor Reactance	0.00 to 100.00 Ω	2	219Dh	413	16bit
C2.2.6	Ld Inductance	0.00 to 650.00 mH	2	21B2h	434	16bit
C2.2.7	Lq Inductance	0.00 to 650.00 mH	2	21B1h	433	16bit
C2.2.8	Ke Constant	0.0 to 2000.0	1	21B3h	435	16bit
C3 Configurations\Control						
C3.1	Configuration					
C3.1.1	Control Type	0 = Scalar 1 = VVW+ 2 = Encoder Vector 3 = Sensorless Vector		20CAh	202	enum
C3.2	Scalar and VVW+ Control					
C3.2.1	V/F Curve					
C3.2.1.1	Manual Torque Boost	0.0 to 20.0 %	1	2088h	136	TIME
C3.2.1.2	Low Output Voltage	0.0 to 100.0 %	1	2090h	144	TIME
C3.2.1.3	Interm. Output Voltage	0.0 to 100.0 %	1	208Fh	143	TIME
C3.2.1.4	Maximum Output Voltage	0.0 to 100.0 %	1	208Eh	142	TIME
C3.2.1.5	Low Speed	0.0 to 200.0 %	1	2093h	147	16bit
C3.2.1.6	Intermediate Speed	0.0 to 200.0 %	1	2092h	146	16bit
C3.2.1.7	Field Weakening Start Speed	0.0 to 200.0 %	1	2091h	145	16bit
C3.2.1.8	Rated Flux	0.0 to 120.0 %	1	2094h	148	TIME
C3.2.2	VVW+ Optimization					
C3.2.2.1.1	Slip Compensator Gain	0.00 to 10.00	2	2BCEh	3022	16bit
C3.2.2.1.2	Voltage Comp. Gain	0.00 to 5.00	2	2BCFh	3023	16bit
C3.2.2.1.3	Filter	1 to 100 ms	0	2C10h	3088	16bit
C3.2.2.2.1	MTPA Function	0 = Disable 1 = Enable		226Bh	619	enum

Parameter	Description	Range of values	Decimal places	Index	Net Id	Size
C3.2.2.2.2	MTPA Optimizer	0 = Disable 1 = Enable		2265h	613	enum
C3.2.2.2.3	MTPA Minimum Speed	0 to 100 %	0	226Ah	618	16bit
C3.2.2.2.4	Efficiency Adjustment Gain	0.000 to 4.000	3	226Ch	620	16bit
C3.2.2.2.5	Kp MTPA Gain	0.000 to 1.000	3	2269h	617	16bit
C3.2.2.2.6	Ki MTPA Gain	0.000 to 1.000	3	2268h	616	16bit
C3.2.2.2.7	MTPA Reference	0 to 100 %	0	2267h	615	s16bit
C3.2.2.2.8	MTPA Minimum Voltage	0 to 100 %	0	2266h	614	16bit
C3.2.2.2.9	Voltage Comp. Gain	0.00 to 5.00	2	2C28h	3112	16bit
C3.2.3	Current Stabilization					
C3.2.3.1	Enable Function	0 = Disable 1 = Enable		2167h	359	enum
C3.2.3.2	Stabilization Kp Gain	0.000 to 1.999	3	226Dh	621	16bit
C3.2.3.3	Stabilization Ki Gain	0.000 to 1.999	3	226Eh	622	16bit
C3.2.3.4	Stab. PI Saturation	0.0 to 10.0 %	1	226Fh	623	16bit
C3.2.3.5	Max. Operation Freq.	0 to 300 %	0	2BFh	3067	16bit
C3.2.4	Pre-Magnetization					
C3.2.4.1	Enable Function	0 = Disable 1 = Enable		2C05h	3077	enum
C3.2.4.2	Current	0 to 350 %	0	2BD1h	3025	16bit
C3.2.4.3	Time	0 to 5000 ms	0	2BD0h	3024	16bit
C3.2.4.4	Gain	1.0 to 7.0	1	2BD3h	3027	16bit
C3.2.5	I/F Control					
C3.2.5.1	Enable	0 = Disable 1 = Enable		2C15h	3093	enum
C3.2.5.2	Enable at Reversal	0 = Disable 1 = Enable		2C1Bh	3099	enum
C3.2.5.3	Current	0 to 200 %	0	2C16h	3094	16bit
C3.2.5.4	Transition Speed	0 to 100 %	0	2C17h	3095	16bit
C3.2.5.5	Drag Time	0 to 10 s	0	2C18h	3096	16bit
C3.2.5.6	Drag Speed	0 to 50 %	0	2C19h	3097	16bit
C3.3	Vector Control					
C3.3.1	Configuration					
C3.3.1.1	Control Mode	0 = Speed 1 = Torque 2 = Defined by DI		2BB8h	3000	enum
C3.3.1.2	Control Mode DI Config.	0 = Inactive 1 = DI X-1 2 = DI X-2 3 = DI X-3 4 = DI X-4 5 = DI X-5		2BB9h	3001	enum



Parameter	Description	Range of values	Decimal places	Index	Net Id	Size
		6 = DI X-6 7 = DI A-1 8 = DI A-2 9 = DI A-3 10 = DI A-4 11 = DI A-5 12 = DI A-6 13 = DI A-7 14 = DI A-8 15 = DI B-1 16 = DI B-2 17 = DI B-3 18 = DI B-4 19 = DI B-5 20 = DI B-6 21 = DI B-7 22 = DI B-8 23 = DI C-1 24 = DI C-2 25 = DI C-3 26 = DI C-4 27 = DI C-5 28 = DI C-6 29 = DI C-7 30 = DI C-8 31 = DI D-1 32 = DI D-2 33 = DI D-3 34 = DI D-4 35 = DI D-5 36 = DI D-6 37 = DI D-7 38 = DI D-8 39 = DI E-1 40 = DI E-2 41 = DI E-3 42 = DI E-4 43 = DI E-5 44 = DI E-6 45 = DI E-7 46 = DI E-8 47 = DI F-1 48 = DI F-2 49 = DI F-3 50 = DI F-4 51 = DI F-5 52 = DI F-6 53 = DI F-7 54 = DI F-8 55 = DI G-1 56 = DI G-2				

Parameter	Description	Range of values	Decimal places	Index	Net Id	Size
		57 = DI G-3 58 = DI G-4 59 = DI G-5 60 = DI G-6 61 = DI G-7 62 = DI G-8				
C3.3.1.3	Control Encoder	0 = Slot X 1 = Slot A 2 = Slot B 3 = Slot C 4 = Slot D 5 = Slot E 6 = Slot F 7 = Slot G 8 = None		2BC9h	3017	enum
C3.3.1.6	Magnetization Mode	0 = General Enable 1 = Run/Stop		20B5h	181	enum
C3.3.2	Regulators					
C3.3.2.1.1	Adaptive Gain	0 = Disable 1 = Enable		20A0h	160	enum
C3.3.2.1.2	Proportional Gain	0.0 to 50.0	1	20A1h	161	16bit
C3.3.2.1.3	Integral Gain	0.001 to 1.000	3	20A2h	162	16bit
C3.3.2.1.4	Differential Gain	0.00 to 7.99	2	20A6h	166	16bit
C3.3.2.1.5	Filter	12 to 1000 ms	0	20A5h	165	16bit
C3.3.2.2.1	Proportional Gain	0.00 to 5.00	2	2BBAh	3002	16bit
C3.3.2.2.2	Integral Gain	0.000 to 1.000	3	2BBBh	3003	16bit
C3.3.2.2.3	Differential Gain	0.00 to 7.99	2	2C0Ch	3084	16bit
C3.3.2.2.4	Filter	12 to 10000 ms	0	2BC8h	3016	16bit
C3.3.2.3.1	Rated Flux	0.0 to 120.0 %	1	20B2h	178	16bit
C3.3.2.3.2	Proportional Gain	0.00 to 5.00	2	20AFh	175	16bit
C3.3.2.3.3	Integral Gain	0.00 to 100.00	2	20B0h	176	16bit
C3.3.2.4.1	Id Prop. Gain	0.00 to 5.00	2	21B8h	440	16bit
C3.3.2.4.2	Id Integral Gain	0.01 to 100.00	2	21B9h	441	16bit
C3.3.2.4.3	Iq Prop. Gain	0.00 to 5.00	2	21B6h	438	16bit
C3.3.2.4.4	Iq Integral Gain	0.01 to 100.00	2	21B7h	439	16bit
C3.3.3	Output Voltage Limiter					
C3.3.3.1	Maximum Output Voltage	0.0 to 120.0 %	1	20BEh	190	16bit
C3.3.3.2	Proportional Gain	0.00 to 5.00	2	2BD6h	3030	16bit
C3.3.3.3	Integral Gain	0.00 to 100.00	2	2BD7h	3031	16bit
C3.3.3.4	Speed for MTPV	0 to 600 %	0	2C27h	3111	16bit
C3.3.4	Torque Mode					
C3.3.4.1.1	Forward Speed	0 to 32000 rpm	0	20ABh	171	16bit
C3.3.4.1.2	Reverse Speed	0 to 32000 rpm	0	20ACh	172	16bit
C3.3.4.1.3	Proportional Gain	0.00 to 5.00	2	2BE3h	3043	16bit
C3.3.4.1.4	Integral Gain	0.000 to 1.000	3	2BE4h	3044	16bit
C3.3.5	Speed Mode					
C3.3.5.1.1	Global Torque	0.0 to 400.0 %	1	2BC7h	3015	16bit

Parameter	Description	Range of values	Decimal places	Index	Net Id	Size
C3.3.5.1.2	Torque Q1	0.0 to 400.0 %	1	20A9h	169	16bit
C3.3.5.1.3	Torque Q2	0.0 to 400.0 %	1	20AAh	170	16bit
C3.3.5.1.4	Torque Q3	0.0 to 400.0 %	1	2BC5h	3013	16bit
C3.3.5.1.5	Torque Q4	0.0 to 400.0 %	1	2BC6h	3014	16bit
C3.3.5.1.6	Global Torque AI Config.	0 = Inactive 1 = AI X-1 2 = AI X-2 3 = AI A-1 4 = AI A-2 5 = AI A-3 6 = Not used 7 = AI B-1 8 = AI B-2 9 = AI B-3 10 = Not used 11 = AI C-1 12 = AI C-2 13 = AI C-3 14 = Not used 15 = AI D-1 16 = AI D-2 17 = AI D-3 18 = Not used 19 = AI E-1 20 = AI E-2 21 = AI E-3 22 = Not used 23 = AI F-1 24 = AI F-2 25 = AI F-3 26 = Not used 27 = AI G-1 28 = AI G-2 29 = AI G-3 30 = Not used		2BC3h	3011	enum
C3.3.5.1.7	Proportional Gain	0.00 to 5.00	2	2BD8h	3032	16bit
C3.3.5.1.8	Integral Gain	0.00 to 100.00	2	2BD9h	3033	16bit
C3.3.7	Speed Steady State Estimator					
C3.3.7.1	Speed Setting	0.10 to 10.00	2	2C07h	3079	16bit
C3.3.7.2	Regenerative Compensator	0.00 to 2.00	2	2BF3h	3059	16bit
C3.3.7.3	Proportional Gain	0.00 to 10.00	2	2BEDh	3053	16bit
C3.3.7.4	Integral Gain	0.00 to 10.00	2	2BEEh	3054	16bit
C3.3.7.5	Synchronous Angle Filter	1 to 15 ms	0	2C0Bh	3083	16bit
C3.3.7.6	Observer transition speed	0 to 50 %	0	2C1Dh	3101	16bit
C3.3.7.7	Home Position Displacement	-50 to 50 °	0	2C1Fh	3103	s16bit
C3.3.8	Low Speed Estimator					
C3.3.8.1	Enable Function	0 = Disable 1 = Enable		2BE8h	3048	enum

Parameter	Description	Range of values	Decimal places	Index	Net Id	Size
C3.3.8.2	Carrier Amplitude	0.00 to 50.00	2	2BE9h	3049	16bit
C3.3.8.3	Carrier Frequency	0 to 5000 Hz	0	2BEAh	3050	16bit
C3.3.8.4	Proportional Gain	0.00 to 10.00	2	2BEBh	3051	16bit
C3.3.8.5	Integral Gain	0.00 to 10.00	2	2BEC h	3052	16bit
C3.3.8.6	Identification of the Magnetic Pole	0.00 to 0.50	2	2C1Eh	3102	16bit
C3.3.9	Online Parameters Estimator					
C3.3.9.1	Estimator Configuration	Bit 0 = Enable Xm Estimator Bit 1 = Enable Taus Estimator Bit 2 = Enable Taur Estimator		2BF2h	3058	3bit
C3.3.10	Maximum Torque per Ampere					
C3.3.10.1	MTPA Manual Setting	0.00 to 2.00	2	2C20h	3104	16bit
C3.4	Current Limiter					
C3.4.1	Actuation Level	0 to 300 %	0	2087h	135	16bit
C3.4.3	Proportional Gain	0.00 to 5.00	2	2BDAh	3034	16bit
C3.4.4	Integral Gain	0.00 to 100.00	2	2BDBh	3035	16bit
C3.4.5	Overcurrent Fault Level	100 to 250 %	0	2C26h	3110	16bit
C3.5	DC Link Voltage Limiter					
C3.5.1	DC Link Volt. Limit. Config.					
C3.5.1.1	Enable Function	0 = Disable 1 = Enable		2BD5h	3029	enum
C3.5.2	Scalar and VVW+ Control					
C3.5.2.1	DC Link Volt. Lim.-Level	114.0 to 160.0 %	1	2097h	151	16bit
C3.5.2.2	DC Link Volt. Lim.-Kp Gain	0.00 to 5.00	2	2098h	152	16bit
C3.5.2.3	DC Link Volt. Lim.-Ki Gain	0.000 to 5.000	3	2BCAh	3018	16bit
C3.5.2.4	DC Link Volt. Lim.-Est. Gain	0.000 to 9.999	3	2BD2h	3026	s16bit
C3.5.3	Vector Control					
C3.5.3.1	Optim. Braking Func. Enable	0 = No 1 = Yes		20B8h	184	enum
C3.5.3.2	DC Link Volt. Lim.-Level	114.0 to 160.0 %	1	20B9h	185	16bit
C3.5.3.3	DC Link Volt. Lim.-Kp Gain	0.00 to 5.00	2	20BAh	186	16bit
C3.5.3.4	DC Link Volt. Lim.-Ki Gain	0.000 to 5.000	3	20BBh	187	16bit
C3.6	Dynamic Braking					
C3.6.1	DC Link Voltage Level	0.1 to 100.0 %	1	2099h	153	16bit
C3.6.2	Resistor	0.0 to 500.0 Ω	1	209Ah	154	16bit
C3.6.3	Power	0.02 to 650.00 kW	2	209Bh	155	16bit
C3.7	DC Braking					
C3.7.1	Enable Function	0 = Disable 1 = Only Start 2 = Only Stop 3 = Start and Stop 4 = Always Enabled		2133h	307	enum
C3.7.2	DC-Braking Start Time	0.0 to 15.0 s	1	212Bh	299	16bit
C3.7.3	DC-Braking Stop Time	0.0 to 15.0 s	1	212Ch	300	16bit
C3.7.4	Starting Speed	0 to 450 rpm	0	212Dh	301	16bit

Parameter	Description	Range of values	Decimal places	Index	Net Id	Size
C3.7.5	Current	0.0 to 100.0 %	1	212Eh	302	16bit
C3.8	Flying Start					
C3.8.1	Flying Start Setting					
C3.8.1.1	Enable Function	0 = Disable 1 = Enable		2BC0h	3008	enum
C3.8.1.2	Function Reset	0 = General Enable 1 = Run/Stop		2147h	327	enum
C3.8.1.3	Tracking	0 = Two Trackings 1 = One Tracking		2148h	328	enum
C3.8.1.4	Ramp	0.2 to 60.0 s	1	214Bh	331	16bit
C3.8.1.5	Disable Flying Start	0 = Inactive 1 = DI X-1 2 = DI X-2 3 = DI X-3 4 = DI X-4 5 = DI X-5 6 = DI X-6 7 = DI A-1 8 = DI A-2 9 = DI A-3 10 = DI A-4 11 = DI A-5 12 = DI A-6 13 = DI A-7 14 = DI A-8 15 = DI B-1 16 = DI B-2 17 = DI B-3 18 = DI B-4 19 = DI B-5 20 = DI B-6 21 = DI B-7 22 = DI B-8 23 = DI C-1 24 = DI C-2 25 = DI C-3 26 = DI C-4 27 = DI C-5 28 = DI C-6 29 = DI C-7 30 = DI C-8 31 = DI D-1 32 = DI D-2 33 = DI D-3 34 = DI D-4 35 = DI D-5		377Ch	6012	enum

Parameter	Description	Range of values	Decimal places	Index	Net Id	Size
		36 = DI D-6 37 = DI D-7 38 = DI D-8 39 = DI E-1 40 = DI E-2 41 = DI E-3 42 = DI E-4 43 = DI E-5 44 = DI E-6 45 = DI E-7 46 = DI E-8 47 = DI F-1 48 = DI F-2 49 = DI F-3 50 = DI F-4 51 = DI F-5 52 = DI F-6 53 = DI F-7 54 = DI F-8 55 = DI G-1 56 = DI G-2 57 = DI G-3 58 = DI G-4 59 = DI G-5 60 = DI G-6 61 = DI G-7 62 = DI G-8				
C3.8.2	Scalar and VVW+ Control					
C3.8.2.1	Current	0.0 to 100.0 %	1	214Ch	332	16bit
C3.8.3	Vector Control					
C3.8.3.1	Flux Reference	0.0 to 100.0 %	1	2149h	329	TIME
C3.9	Ride-Through					
C3.9.1	Ride-Through Config.					
C3.9.1.1	Function Enable	0 = Disable 1 = Enable		2140h	320	enum
C3.9.2	Scalar and VVW+ Control					
C3.9.2.1	DC Link Volt.-Ride-Through	76.0 to 95.0 %	1	2BCDh	3021	16bit
C3.9.2.2	Ride-Through-Gain Kp	0.00 to 2.00	2	2BCBh	3019	16bit
C3.9.2.3	Ride-Through-Gain Ki	0.000 to 1.000	3	2BCCh	3020	16bit
C3.9.3	Vector Control					
C3.9.3.1	DC Link Volt.-Ride-Through	76.0 to 95.0 %	1	2142h	322	16bit
C3.9.3.2	Ride-Through-Gain Kp	0.00 to 2.00	2	2145h	325	16bit
C3.9.3.3	Ride-Through-Gain Ki	0.000 to 1.000	3	2146h	326	16bit
C3.10	Advanced Energy Saving					
C3.10.1	Enable Function	0 = Disable 1 = Enable		2BD4h	3028	enum
C3.10.2	Adv. Optimum Flux Config.			2250h	592	enum

Parameter	Description	Range of values	Decimal places	Index	Net Id	Size
		0 = Disable 1 = Enable				
C3.10.3	Cos phi Reference	0.50 to 0.99	2	2BC1h	3009	s16bit
C3.10.4	Maximum Torque	0 to 150 %	0	224Ch	588	s16bit
C3.10.5	Minimum Voltage	40 to 80 %	0	224Dh	589	s16bit
C3.10.6	Minimum Speed	0 to 100 %	0	224Eh	590	s16bit
C3.10.7	Torque Hysteresis	0 to 30 %	0	224Fh	591	s16bit
C4 Configurations\Commands and References						
C4.1	LOC/REM Mode Config.					
C4.1.1	Command mode	0 = Always Local 1 = Remote 1 2 = Remote 2 3 = Serial 4 = Anybus 5 = CAN/CO/DN 6 = SoftPLC 7 = Not used 8 = Ethernet 9 = Digital Input (DI)		20DCh	220	enum
C4.1.2	DI Remote 1/Remote 2	0 = Inactive 1 = DI X-1 2 = DI X-2 3 = DI X-3 4 = DI X-4 5 = DI X-5 6 = DI X-6 7 = DI A-1 8 = DI A-2 9 = DI A-3 10 = DI A-4 11 = DI A-5 12 = DI A-6 13 = DI A-7 14 = DI A-8 15 = DI B-1 16 = DI B-2 17 = DI B-3 18 = DI B-4 19 = DI B-5 20 = DI B-6 21 = DI B-7 22 = DI B-8 23 = DI C-1 24 = DI C-2 25 = DI C-3 26 = DI C-4 27 = DI C-5 28 = DI C-6		377Bh	6011	enum

Parameter	Description	Range of values	Decimal places	Index	Net Id	Size
		29 = DI C-7 30 = DI C-8 31 = DI D-1 32 = DI D-2 33 = DI D-3 34 = DI D-4 35 = DI D-5 36 = DI D-6 37 = DI D-7 38 = DI D-8 39 = DI E-1 40 = DI E-2 41 = DI E-3 42 = DI E-4 43 = DI E-5 44 = DI E-6 45 = DI E-7 46 = DI E-8 47 = DI F-1 48 = DI F-2 49 = DI F-3 50 = DI F-4 51 = DI F-5 52 = DI F-6 53 = DI F-7 54 = DI F-8 55 = DI G-1 56 = DI G-2 57 = DI G-3 58 = DI G-4 59 = DI G-5 60 = DI G-6 61 = DI G-7 62 = DI G-8				
C4.1.3	HMI LOC/REM Key	0 = Disable 1 = Enable		464Bh	9803	enum
C4.2	Commands					
C4.2.1	R1 Command Config.					
C4.2.1.1	General Enable	0 = Always enabled 1 = HMI 2 = Serial 3 = Anybus 4 = CAN/CO/DN 5 = SoftPLC 6 = Not used 7 = Ethernet 8 = Digital Input (DI)		20F0h	240	enum
C4.2.1.2	Run/Stop			20E0h	224	enum

Parameter	Description	Range of values	Decimal places	Index	Net Id	Size
		0 = HMI I/O Keys 1 = Serial 2 = Anybus 3 = CAN/CO/DN 4 = SoftPLC 5 = Not used 6 = Ethernet 7 = Run/Stop DI 8 = Forward/Reverse DI 9 = 3-Wire Start/Stop DI				
C4.2.1.3	Direction of Rotation	0 = Forward 1 = HMI DR Key 2 = Serial 3 = Anybus 4 = CAN/CO/DN 5 = SoftPLC 6 = Not used 7 = Ethernet 8 = Direction of Rotation DI 9 = Forward/Reverse DI 10 = Speed Reference		20DFh	223	enum
C4.2.1.4	JOG	0 = Inactive 1 = HMI JOG Key 2 = Serial 3 = Anybus 4 = CAN/CO/DN 5 = SoftPLC 6 = Not used 7 = Ethernet 8 = Digital Input (DI)		20E1h	225	enum
C4.2.2	R2 Command Config.					
C4.2.2.1	General Enable	0 = Always enabled 1 = HMI 2 = Serial 3 = Anybus 4 = CAN/CO/DN 5 = SoftPLC 6 = Not used 7 = Ethernet 8 = Digital Input (DI)		20F1h	241	enum
C4.2.2.2	Run/Stop	0 = HMI I/O Keys 1 = Serial 2 = Anybus 3 = CAN/CO/DN 4 = SoftPLC 5 = Not used		20E3h	227	enum

Parameter	Description	Range of values	Decimal places	Index	Net Id	Size
C4.2.2.3	Direction of Rotation	6 = Ethernet 7 = Run/Stop DI 8 = Forward/Reverse DI 9 = 3-Wire Start/Stop DI		20E2h	226	enum
C4.2.2.4	JOG	0 = Forward 1 = HMI DR Key 2 = Serial 3 = Anybus 4 = CAN/CO/DN 5 = SoftPLC 6 = Not used 7 = Ethernet 8 = Direction of Rotation DI 9 = Forward/Reverse DI 10 = Speed Reference		20E4h	228	enum
C4.2.3	DI Config. for Commands					
C4.2.3.1	General Enable	0 = Inactive 1 = DI X-1 2 = DI X-2 3 = DI X-3 4 = DI X-4 5 = DI X-5 6 = DI X-6 7 = DI A-1 8 = DI A-2 9 = DI A-3 10 = DI A-4 11 = DI A-5 12 = DI A-6 13 = DI A-7 14 = DI A-8 15 = DI B-1 16 = DI B-2 17 = DI B-3 18 = DI B-4 19 = DI B-5 20 = DI B-6 21 = DI B-7		3770h	6000	enum



Parameter	Description	Range of values	Decimal places	Index	Net Id	Size
		22 = DI B-8 23 = DI C-1 24 = DI C-2 25 = DI C-3 26 = DI C-4 27 = DI C-5 28 = DI C-6 29 = DI C-7 30 = DI C-8 31 = DI D-1 32 = DI D-2 33 = DI D-3 34 = DI D-4 35 = DI D-5 36 = DI D-6 37 = DI D-7 38 = DI D-8 39 = DI E-1 40 = DI E-2 41 = DI E-3 42 = DI E-4 43 = DI E-5 44 = DI E-6 45 = DI E-7 46 = DI E-8 47 = DI F-1 48 = DI F-2 49 = DI F-3 50 = DI F-4 51 = DI F-5 52 = DI F-6 53 = DI F-7 54 = DI F-8 55 = DI G-1 56 = DI G-2 57 = DI G-3 58 = DI G-4 59 = DI G-5 60 = DI G-6 61 = DI G-7 62 = DI G-8				
C4.2.3.2	Run/Stop	0 = Inactive 1 = DI X-1 2 = DI X-2 3 = DI X-3 4 = DI X-4 5 = DI X-5 6 = DI X-6 7 = DI A-1 8 = DI A-2		3774h	6004	enum



Parameter	Description	Range of values	Decimal places	Index	Net Id	Size
		9 = DI A-3 10 = DI A-4 11 = DI A-5 12 = DI A-6 13 = DI A-7 14 = DI A-8 15 = DI B-1 16 = DI B-2 17 = DI B-3 18 = DI B-4 19 = DI B-5 20 = DI B-6 21 = DI B-7 22 = DI B-8 23 = DI C-1 24 = DI C-2 25 = DI C-3 26 = DI C-4 27 = DI C-5 28 = DI C-6 29 = DI C-7 30 = DI C-8 31 = DI D-1 32 = DI D-2 33 = DI D-3 34 = DI D-4 35 = DI D-5 36 = DI D-6 37 = DI D-7 38 = DI D-8 39 = DI E-1 40 = DI E-2 41 = DI E-3 42 = DI E-4 43 = DI E-5 44 = DI E-6 45 = DI E-7 46 = DI E-8 47 = DI F-1 48 = DI F-2 49 = DI F-3 50 = DI F-4 51 = DI F-5 52 = DI F-6 53 = DI F-7 54 = DI F-8 55 = DI G-1 56 = DI G-2 57 = DI G-3 58 = DI G-4 59 = DI G-5				



Parameter	Description	Range of values	Decimal places	Index	Net Id	Size
C4.2.3.3	3-Wire Start	60 = DI G-6 61 = DI G-7 62 = DI G-8 0 = Inactive 1 = DI X-1 2 = DI X-2 3 = DI X-3 4 = DI X-4 5 = DI X-5 6 = DI X-6 7 = DI A-1 8 = DI A-2 9 = DI A-3 10 = DI A-4 11 = DI A-5 12 = DI A-6 13 = DI A-7 14 = DI A-8 15 = DI B-1 16 = DI B-2 17 = DI B-3 18 = DI B-4 19 = DI B-5 20 = DI B-6 21 = DI B-7 22 = DI B-8 23 = DI C-1 24 = DI C-2 25 = DI C-3 26 = DI C-4 27 = DI C-5 28 = DI C-6 29 = DI C-7 30 = DI C-8 31 = DI D-1 32 = DI D-2 33 = DI D-3 34 = DI D-4 35 = DI D-5 36 = DI D-6 37 = DI D-7 38 = DI D-8 39 = DI E-1 40 = DI E-2 41 = DI E-3 42 = DI E-4 43 = DI E-5 44 = DI E-6 45 = DI E-7 46 = DI E-8		3775h	6005	enum

Parameter	Description	Range of values	Decimal places	Index	Net Id	Size
		47 = DI F-1 48 = DI F-2 49 = DI F-3 50 = DI F-4 51 = DI F-5 52 = DI F-6 53 = DI F-7 54 = DI F-8 55 = DI G-1 56 = DI G-2 57 = DI G-3 58 = DI G-4 59 = DI G-5 60 = DI G-6 61 = DI G-7 62 = DI G-8				
C4.2.3.4	3-Wire Stop	0 = Inactive 1 = DI X-1 2 = DI X-2 3 = DI X-3 4 = DI X-4 5 = DI X-5 6 = DI X-6 7 = DI A-1 8 = DI A-2 9 = DI A-3 10 = DI A-4 11 = DI A-5 12 = DI A-6 13 = DI A-7 14 = DI A-8 15 = DI B-1 16 = DI B-2 17 = DI B-3 18 = DI B-4 19 = DI B-5 20 = DI B-6 21 = DI B-7 22 = DI B-8 23 = DI C-1 24 = DI C-2 25 = DI C-3 26 = DI C-4 27 = DI C-5 28 = DI C-6 29 = DI C-7 30 = DI C-8 31 = DI D-1 32 = DI D-2 33 = DI D-3		3776h	6006	enum

Parameter	Description	Range of values	Decimal places	Index	Net Id	Size
		34 = DI D-4 35 = DI D-5 36 = DI D-6 37 = DI D-7 38 = DI D-8 39 = DI E-1 40 = DI E-2 41 = DI E-3 42 = DI E-4 43 = DI E-5 44 = DI E-6 45 = DI E-7 46 = DI E-8 47 = DI F-1 48 = DI F-2 49 = DI F-3 50 = DI F-4 51 = DI F-5 52 = DI F-6 53 = DI F-7 54 = DI F-8 55 = DI G-1 56 = DI G-2 57 = DI G-3 58 = DI G-4 59 = DI G-5 60 = DI G-6 61 = DI G-7 62 = DI G-8				
C4.2.3.5	Forward	0 = Inactive 1 = DI X-1 2 = DI X-2 3 = DI X-3 4 = DI X-4 5 = DI X-5 6 = DI X-6 7 = DI A-1 8 = DI A-2 9 = DI A-3 10 = DI A-4 11 = DI A-5 12 = DI A-6 13 = DI A-7 14 = DI A-8 15 = DI B-1 16 = DI B-2 17 = DI B-3 18 = DI B-4 19 = DI B-5 20 = DI B-6		3777h	6007	enum



Parameter	Description	Range of values	Decimal places	Index	Net Id	Size
		21 = DI B-7 22 = DI B-8 23 = DI C-1 24 = DI C-2 25 = DI C-3 26 = DI C-4 27 = DI C-5 28 = DI C-6 29 = DI C-7 30 = DI C-8 31 = DI D-1 32 = DI D-2 33 = DI D-3 34 = DI D-4 35 = DI D-5 36 = DI D-6 37 = DI D-7 38 = DI D-8 39 = DI E-1 40 = DI E-2 41 = DI E-3 42 = DI E-4 43 = DI E-5 44 = DI E-6 45 = DI E-7 46 = DI E-8 47 = DI F-1 48 = DI F-2 49 = DI F-3 50 = DI F-4 51 = DI F-5 52 = DI F-6 53 = DI F-7 54 = DI F-8 55 = DI G-1 56 = DI G-2 57 = DI G-3 58 = DI G-4 59 = DI G-5 60 = DI G-6 61 = DI G-7 62 = DI G-8				
C4.2.3.6	Reverse	0 = Inactive 1 = DI X-1 2 = DI X-2 3 = DI X-3 4 = DI X-4 5 = DI X-5 6 = DI X-6 7 = DI A-1		3778h	6008	enum



Parameter	Description	Range of values	Decimal places	Index	Net Id	Size
		8 = DI A-2 9 = DI A-3 10 = DI A-4 11 = DI A-5 12 = DI A-6 13 = DI A-7 14 = DI A-8 15 = DI B-1 16 = DI B-2 17 = DI B-3 18 = DI B-4 19 = DI B-5 20 = DI B-6 21 = DI B-7 22 = DI B-8 23 = DI C-1 24 = DI C-2 25 = DI C-3 26 = DI C-4 27 = DI C-5 28 = DI C-6 29 = DI C-7 30 = DI C-8 31 = DI D-1 32 = DI D-2 33 = DI D-3 34 = DI D-4 35 = DI D-5 36 = DI D-6 37 = DI D-7 38 = DI D-8 39 = DI E-1 40 = DI E-2 41 = DI E-3 42 = DI E-4 43 = DI E-5 44 = DI E-6 45 = DI E-7 46 = DI E-8 47 = DI F-1 48 = DI F-2 49 = DI F-3 50 = DI F-4 51 = DI F-5 52 = DI F-6 53 = DI F-7 54 = DI F-8 55 = DI G-1 56 = DI G-2 57 = DI G-3 58 = DI G-4				

Parameter	Description	Range of values	Decimal places	Index	Net Id	Size
C4.2.3.7	Quick Stop	59 = DI G-5 60 = DI G-6 61 = DI G-7 62 = DI G-8 0 = Inactive 1 = DI X-1 2 = DI X-2 3 = DI X-3 4 = DI X-4 5 = DI X-5 6 = DI X-6 7 = DI A-1 8 = DI A-2 9 = DI A-3 10 = DI A-4 11 = DI A-5 12 = DI A-6 13 = DI A-7 14 = DI A-8 15 = DI B-1 16 = DI B-2 17 = DI B-3 18 = DI B-4 19 = DI B-5 20 = DI B-6 21 = DI B-7 22 = DI B-8 23 = DI C-1 24 = DI C-2 25 = DI C-3 26 = DI C-4 27 = DI C-5 28 = DI C-6 29 = DI C-7 30 = DI C-8 31 = DI D-1 32 = DI D-2 33 = DI D-3 34 = DI D-4 35 = DI D-5 36 = DI D-6 37 = DI D-7 38 = DI D-8 39 = DI E-1 40 = DI E-2 41 = DI E-3 42 = DI E-4 43 = DI E-5 44 = DI E-6 45 = DI E-7		3771h	6001	enum



Parameter	Description	Range of values	Decimal places	Index	Net Id	Size
		46 = DI E-8 47 = DI F-1 48 = DI F-2 49 = DI F-3 50 = DI F-4 51 = DI F-5 52 = DI F-6 53 = DI F-7 54 = DI F-8 55 = DI G-1 56 = DI G-2 57 = DI G-3 58 = DI G-4 59 = DI G-5 60 = DI G-6 61 = DI G-7 62 = DI G-8				
C4.2.3.8	Direction of Rotation	0 = Inactive 1 = DI X-1 2 = DI X-2 3 = DI X-3 4 = DI X-4 5 = DI X-5 6 = DI X-6 7 = DI A-1 8 = DI A-2 9 = DI A-3 10 = DI A-4 11 = DI A-5 12 = DI A-6 13 = DI A-7 14 = DI A-8 15 = DI B-1 16 = DI B-2 17 = DI B-3 18 = DI B-4 19 = DI B-5 20 = DI B-6 21 = DI B-7 22 = DI B-8 23 = DI C-1 24 = DI C-2 25 = DI C-3 26 = DI C-4 27 = DI C-5 28 = DI C-6 29 = DI C-7 30 = DI C-8 31 = DI D-1 32 = DI D-2		377Ah	6010	enum

Parameter	Description	Range of values	Decimal places	Index	Net Id	Size
		33 = DI D-3 34 = DI D-4 35 = DI D-5 36 = DI D-6 37 = DI D-7 38 = DI D-8 39 = DI E-1 40 = DI E-2 41 = DI E-3 42 = DI E-4 43 = DI E-5 44 = DI E-6 45 = DI E-7 46 = DI E-8 47 = DI F-1 48 = DI F-2 49 = DI F-3 50 = DI F-4 51 = DI F-5 52 = DI F-6 53 = DI F-7 54 = DI F-8 55 = DI G-1 56 = DI G-2 57 = DI G-3 58 = DI G-4 59 = DI G-5 60 = DI G-6 61 = DI G-7 62 = DI G-8				
C4.2.3.9	JOG	0 = Inactive 1 = DI X-1 2 = DI X-2 3 = DI X-3 4 = DI X-4 5 = DI X-5 6 = DI X-6 7 = DI A-1 8 = DI A-2 9 = DI A-3 10 = DI A-4 11 = DI A-5 12 = DI A-6 13 = DI A-7 14 = DI A-8 15 = DI B-1 16 = DI B-2 17 = DI B-3 18 = DI B-4 19 = DI B-5		3779h	6009	enum

Parameter	Description	Range of values	Decimal places	Index	Net Id	Size
		20 = DI B-6 21 = DI B-7 22 = DI B-8 23 = DI C-1 24 = DI C-2 25 = DI C-3 26 = DI C-4 27 = DI C-5 28 = DI C-6 29 = DI C-7 30 = DI C-8 31 = DI D-1 32 = DI D-2 33 = DI D-3 34 = DI D-4 35 = DI D-5 36 = DI D-6 37 = DI D-7 38 = DI D-8 39 = DI E-1 40 = DI E-2 41 = DI E-3 42 = DI E-4 43 = DI E-5 44 = DI E-6 45 = DI E-7 46 = DI E-8 47 = DI F-1 48 = DI F-2 49 = DI F-3 50 = DI F-4 51 = DI F-5 52 = DI F-6 53 = DI F-7 54 = DI F-8 55 = DI G-1 56 = DI G-2 57 = DI G-3 58 = DI G-4 59 = DI G-5 60 = DI G-6 61 = DI G-7 62 = DI G-8				
C4.2.3.10	Ramp Selection	0 = Inactive 1 = DI X-1 2 = DI X-2 3 = DI X-3 4 = DI X-4 5 = DI X-5 6 = DI X-6		3773h	6003	enum



Parameter	Description	Range of values	Decimal places	Index	Net Id	Size
		7 = DI A-1 8 = DI A-2 9 = DI A-3 10 = DI A-4 11 = DI A-5 12 = DI A-6 13 = DI A-7 14 = DI A-8 15 = DI B-1 16 = DI B-2 17 = DI B-3 18 = DI B-4 19 = DI B-5 20 = DI B-6 21 = DI B-7 22 = DI B-8 23 = DI C-1 24 = DI C-2 25 = DI C-3 26 = DI C-4 27 = DI C-5 28 = DI C-6 29 = DI C-7 30 = DI C-8 31 = DI D-1 32 = DI D-2 33 = DI D-3 34 = DI D-4 35 = DI D-5 36 = DI D-6 37 = DI D-7 38 = DI D-8 39 = DI E-1 40 = DI E-2 41 = DI E-3 42 = DI E-4 43 = DI E-5 44 = DI E-6 45 = DI E-7 46 = DI E-8 47 = DI F-1 48 = DI F-2 49 = DI F-3 50 = DI F-4 51 = DI F-5 52 = DI F-6 53 = DI F-7 54 = DI F-8 55 = DI G-1 56 = DI G-2 57 = DI G-3				

Parameter	Description	Range of values	Decimal places	Index	Net Id	Size
C4.2.3.11	Fault Reset	58 = DI G-4 59 = DI G-5 60 = DI G-6 61 = DI G-7 62 = DI G-8 0 = Inactive 1 = DI X-1 2 = DI X-2 3 = DI X-3 4 = DI X-4 5 = DI X-5 6 = DI X-6 7 = DI A-1 8 = DI A-2 9 = DI A-3 10 = DI A-4 11 = DI A-5 12 = DI A-6 13 = DI A-7 14 = DI A-8 15 = DI B-1 16 = DI B-2 17 = DI B-3 18 = DI B-4 19 = DI B-5 20 = DI B-6 21 = DI B-7 22 = DI B-8 23 = DI C-1 24 = DI C-2 25 = DI C-3 26 = DI C-4 27 = DI C-5 28 = DI C-6 29 = DI C-7 30 = DI C-8 31 = DI D-1 32 = DI D-2 33 = DI D-3 34 = DI D-4 35 = DI D-5 36 = DI D-6 37 = DI D-7 38 = DI D-8 39 = DI E-1 40 = DI E-2 41 = DI E-3 42 = DI E-4 43 = DI E-5 44 = DI E-6		3772h	6002	enum

Parameter	Description	Range of values	Decimal places	Index	Net Id	Size
		45 = DI E-7 46 = DI E-8 47 = DI F-1 48 = DI F-2 49 = DI F-3 50 = DI F-4 51 = DI F-5 52 = DI F-6 53 = DI F-7 54 = DI F-8 55 = DI G-1 56 = DI G-2 57 = DI G-3 58 = DI G-4 59 = DI G-5 60 = DI G-6 61 = DI G-7 62 = DI G-8				
C4.2.4	HMI Config. for Commands					
C4.2.4.1	Stop Key Function	0 = Stop by Ramp 1 = General Enable to Stop 2 = Quick Stop		20E5h	229	enum
C4.3	References					
C4.3.1	Speed					
C4.3.1.1.1	Minimum Reference	0 to 60000 rpm	0	2085h	133	16bit
C4.3.1.1.2	Maximum Reference	1 to 60000 rpm	0	2086h	134	16bit
C4.3.1.2.1	Remote 1 Mode	0 = HMI 1 = E.P. 2 = Multispeed 3 = Serial 4 = Anybus 5 = CAN/CO/DN 6 = Ethernet 7 = Not used 8 = SoftPLC 9 = Analog Input (AI) 10 = Frequency Input (FI) 11 = PID Controller		20DDh	221	enum
C4.3.1.2.2	Remote 2 Mode	0 = HMI 1 = E.P. 2 = Multispeed 3 = Serial 4 = Anybus 5 = CAN/CO/DN 6 = Ethernet 7 = Not used 8 = SoftPLC		20DEh	222	enum

Parameter	Description	Range of values	Decimal places	Index	Net Id	Size
C4.3.1.3.1	Speed Ref. via HMI	9 = Analog Input (AI) 10 = Frequency Input (FI) 11 = PID Controller 0 to 60000 rpm	0	2079h	121	16bit
C4.3.1.3.2	R1 Speed Ref. AI Config.	0 = Inactive 1 = AI X-1 2 = AI X-2 3 = AI A-1 4 = AI A-2 5 = AI A-3 6 = Not used 7 = AI B-1 8 = AI B-2 9 = AI B-3 10 = Not used 11 = AI C-1 12 = AI C-2 13 = AI C-3 14 = Not used 15 = AI D-1 16 = AI D-2 17 = AI D-3 18 = Not used 19 = AI E-1 20 = AI E-2 21 = AI E-3 22 = Not used 23 = AI F-1 24 = AI F-2 25 = AI F-3 26 = Not used 27 = AI G-1 28 = AI G-2 29 = AI G-3 30 = Not used		3781h	6017	enum
C4.3.1.3.3	Speed Ref. FI Config.	0 = Inactive 1 = FI X-5 2 = FI X-6		3782h	6018	enum
C4.3.1.3.4	R2 Speed Ref. AI Config.	0 = Inactive 1 = AI X-1 2 = AI X-2 3 = AI A-1 4 = AI A-2 5 = AI A-3 6 = Not used 7 = AI B-1 8 = AI B-2 9 = AI B-3		3783h	6019	enum



Parameter	Description	Range of values	Decimal places	Index	Net Id	Size
		10 = Not used 11 = AI C-1 12 = AI C-2 13 = AI C-3 14 = Not used 15 = AI D-1 16 = AI D-2 17 = AI D-3 18 = Not used 19 = AI E-1 20 = AI E-2 21 = AI E-3 22 = Not used 23 = AI F-1 24 = AI F-2 25 = AI F-3 26 = Not used 27 = AI G-1 28 = AI G-2 29 = AI G-3 30 = Not used				
C4.3.1.4.1	DI Increase E.P.	0 = Inactive 1 = DI X-1 2 = DI X-2 3 = DI X-3 4 = DI X-4 5 = DI X-5 6 = DI X-6 7 = DI A-1 8 = DI A-2 9 = DI A-3 10 = DI A-4 11 = DI A-5 12 = DI A-6 13 = DI A-7 14 = DI A-8 15 = DI B-1 16 = DI B-2 17 = DI B-3 18 = DI B-4 19 = DI B-5 20 = DI B-6 21 = DI B-7 22 = DI B-8 23 = DI C-1 24 = DI C-2 25 = DI C-3 26 = DI C-4 27 = DI C-5 28 = DI C-6		3791h	6033	enum



Parameter	Description	Range of values	Decimal places	Index	Net Id	Size
		29 = DI C-7 30 = DI C-8 31 = DI D-1 32 = DI D-2 33 = DI D-3 34 = DI D-4 35 = DI D-5 36 = DI D-6 37 = DI D-7 38 = DI D-8 39 = DI E-1 40 = DI E-2 41 = DI E-3 42 = DI E-4 43 = DI E-5 44 = DI E-6 45 = DI E-7 46 = DI E-8 47 = DI F-1 48 = DI F-2 49 = DI F-3 50 = DI F-4 51 = DI F-5 52 = DI F-6 53 = DI F-7 54 = DI F-8 55 = DI G-1 56 = DI G-2 57 = DI G-3 58 = DI G-4 59 = DI G-5 60 = DI G-6 61 = DI G-7 62 = DI G-8				
C4.3.1.4.2	DI Decrease E.P.	0 = Inactive 1 = DI X-1 2 = DI X-2 3 = DI X-3 4 = DI X-4 5 = DI X-5 6 = DI X-6 7 = DI A-1 8 = DI A-2 9 = DI A-3 10 = DI A-4 11 = DI A-5 12 = DI A-6 13 = DI A-7 14 = DI A-8 15 = DI B-1		3792h	6034	enum

Parameter	Description	Range of values	Decimal places	Index	Net Id	Size
		16 = DI B-2				
		17 = DI B-3				
		18 = DI B-4				
		19 = DI B-5				
		20 = DI B-6				
		21 = DI B-7				
		22 = DI B-8				
		23 = DI C-1				
		24 = DI C-2				
		25 = DI C-3				
		26 = DI C-4				
		27 = DI C-5				
		28 = DI C-6				
		29 = DI C-7				
		30 = DI C-8				
		31 = DI D-1				
		32 = DI D-2				
		33 = DI D-3				
		34 = DI D-4				
		35 = DI D-5				
		36 = DI D-6				
		37 = DI D-7				
		38 = DI D-8				
		39 = DI E-1				
		40 = DI E-2				
		41 = DI E-3				
		42 = DI E-4				
		43 = DI E-5				
		44 = DI E-6				
		45 = DI E-7				
		46 = DI E-8				
		47 = DI F-1				
		48 = DI F-2				
		49 = DI F-3				
		50 = DI F-4				
		51 = DI F-5				
		52 = DI F-6				
		53 = DI F-7				
		54 = DI F-8				
		55 = DI G-1				
		56 = DI G-2				
		57 = DI G-3				
		58 = DI G-4				
		59 = DI G-5				
		60 = DI G-6				
		61 = DI G-7				
		62 = DI G-8				
C4.3.1.5.1	Multispeed Ref. 1	0 to 60000 rpm	0	207Ch	124	16bit
C4.3.1.5.2	Multispeed Ref. 2	0 to 60000 rpm	0	207Dh	125	16bit
C4.3.1.5.3	Multispeed Ref. 3	0 to 60000 rpm	0	207Eh	126	16bit
C4.3.1.5.4	Multispeed Ref. 4	0 to 60000 rpm	0	207Fh	127	16bit

Parameter	Description	Range of values	Decimal places	Index	Net Id	Size
C4.3.1.5.5	Multispeed Ref. 5	0 to 60000 rpm	0	2080h	128	16bit
C4.3.1.5.6	Multispeed Ref. 6	0 to 60000 rpm	0	2081h	129	16bit
C4.3.1.5.7	Multispeed Ref. 7	0 to 60000 rpm	0	2082h	130	16bit
C4.3.1.5.8	Multispeed Ref. 8	0 to 60000 rpm	0	2083h	131	16bit
C4.3.1.5.9	Multispeed 1 DI Config.	0 = Inactive 1 = DI X-1 2 = DI X-2 3 = DI X-3 4 = DI X-4 5 = DI X-5 6 = DI X-6 7 = DI A-1 8 = DI A-2 9 = DI A-3 10 = DI A-4 11 = DI A-5 12 = DI A-6 13 = DI A-7 14 = DI A-8 15 = DI B-1 16 = DI B-2 17 = DI B-3 18 = DI B-4 19 = DI B-5 20 = DI B-6 21 = DI B-7 22 = DI B-8 23 = DI C-1 24 = DI C-2 25 = DI C-3 26 = DI C-4 27 = DI C-5 28 = DI C-6 29 = DI C-7 30 = DI C-8 31 = DI D-1 32 = DI D-2 33 = DI D-3 34 = DI D-4 35 = DI D-5 36 = DI D-6 37 = DI D-7 38 = DI D-8 39 = DI E-1 40 = DI E-2 41 = DI E-3 42 = DI E-4 43 = DI E-5 44 = DI E-6 45 = DI E-7		378Eh	6030	enum

Parameter	Description	Range of values	Decimal places	Index	Net Id	Size
		46 = DI E-8 47 = DI F-1 48 = DI F-2 49 = DI F-3 50 = DI F-4 51 = DI F-5 52 = DI F-6 53 = DI F-7 54 = DI F-8 55 = DI G-1 56 = DI G-2 57 = DI G-3 58 = DI G-4 59 = DI G-5 60 = DI G-6 61 = DI G-7 62 = DI G-8				
C4.3.1.5.10	Multispeed 2 DI Config.	0 = Inactive 1 = DI X-1 2 = DI X-2 3 = DI X-3 4 = DI X-4 5 = DI X-5 6 = DI X-6 7 = DI A-1 8 = DI A-2 9 = DI A-3 10 = DI A-4 11 = DI A-5 12 = DI A-6 13 = DI A-7 14 = DI A-8 15 = DI B-1 16 = DI B-2 17 = DI B-3 18 = DI B-4 19 = DI B-5 20 = DI B-6 21 = DI B-7 22 = DI B-8 23 = DI C-1 24 = DI C-2 25 = DI C-3 26 = DI C-4 27 = DI C-5 28 = DI C-6 29 = DI C-7 30 = DI C-8 31 = DI D-1 32 = DI D-2		378Fh	6031	enum



Parameter	Description	Range of values	Decimal places	Index	Net Id	Size
		33 = DI D-3 34 = DI D-4 35 = DI D-5 36 = DI D-6 37 = DI D-7 38 = DI D-8 39 = DI E-1 40 = DI E-2 41 = DI E-3 42 = DI E-4 43 = DI E-5 44 = DI E-6 45 = DI E-7 46 = DI E-8 47 = DI F-1 48 = DI F-2 49 = DI F-3 50 = DI F-4 51 = DI F-5 52 = DI F-6 53 = DI F-7 54 = DI F-8 55 = DI G-1 56 = DI G-2 57 = DI G-3 58 = DI G-4 59 = DI G-5 60 = DI G-6 61 = DI G-7 62 = DI G-8				
C4.3.1.5.11	Multispeed 3 DI Config.	0 = Inactive 1 = DI X-1 2 = DI X-2 3 = DI X-3 4 = DI X-4 5 = DI X-5 6 = DI X-6 7 = DI A-1 8 = DI A-2 9 = DI A-3 10 = DI A-4 11 = DI A-5 12 = DI A-6 13 = DI A-7 14 = DI A-8 15 = DI B-1 16 = DI B-2 17 = DI B-3 18 = DI B-4 19 = DI B-5		3790h	6032	enum

Parameter	Description	Range of values	Decimal places	Index	Net Id	Size
		20 = DI B-6 21 = DI B-7 22 = DI B-8 23 = DI C-1 24 = DI C-2 25 = DI C-3 26 = DI C-4 27 = DI C-5 28 = DI C-6 29 = DI C-7 30 = DI C-8 31 = DI D-1 32 = DI D-2 33 = DI D-3 34 = DI D-4 35 = DI D-5 36 = DI D-6 37 = DI D-7 38 = DI D-8 39 = DI E-1 40 = DI E-2 41 = DI E-3 42 = DI E-4 43 = DI E-5 44 = DI E-6 45 = DI E-7 46 = DI E-8 47 = DI F-1 48 = DI F-2 49 = DI F-3 50 = DI F-4 51 = DI F-5 52 = DI F-6 53 = DI F-7 54 = DI F-8 55 = DI G-1 56 = DI G-2 57 = DI G-3 58 = DI G-4 59 = DI G-5 60 = DI G-6 61 = DI G-7 62 = DI G-8				
C4.3.1.6.1	Speed 1	0 to 60000 rpm	0	212Fh	303	16bit
C4.3.1.6.2	Speed 2	0 to 60000 rpm	0	2130h	304	16bit
C4.3.1.6.3	Speed 3	0 to 60000 rpm	0	2131h	305	16bit
C4.3.1.6.4	Skip Range	0 to 750 rpm	0	2132h	306	16bit
C4.3.2	JOG Speed					
C4.3.2.1	JOG Reference	0 to 60000 rpm	0	2076h	118	16bit
C4.3.3	Torque					
C4.3.3.1	Torque Reference via HMI	-400.0 to 400.0 %	1	2077h	119	s16bit

Parameter	Description	Range of values	Decimal places	Index	Net Id	Size
C4.3.3.2	Maximum Torque	0.0 to 400.0 %	1	2BFEh	3070	16bit
C4.3.3.3	Minimum Torque	0.0 to 400.0 %	1	2BFFh	3071	16bit
C4.3.3.4	Torque Ref. Source	0 = HMI 1 = Analog Input (AI) 2 = Frequency Input (FI)		464Ah	9802	enum
C4.3.3.5	Torque Ref. AI Config.	0 = Inactive 1 = AI X-1 2 = AI X-2 3 = AI A-1 4 = AI A-2 5 = AI A-3 6 = Not used 7 = AI B-1 8 = AI B-2 9 = AI B-3 10 = Not used 11 = AI C-1 12 = AI C-2 13 = AI C-3 14 = Not used 15 = AI D-1 16 = AI D-2 17 = AI D-3 18 = Not used 19 = AI E-1 20 = AI E-2 21 = AI E-3 22 = Not used 23 = AI F-1 24 = AI F-2 25 = AI F-3 26 = Not used 27 = AI G-1 28 = AI G-2 29 = AI G-3 30 = Not used		4649h	9801	enum
C4.3.3.6	Torque Ref. FI Config.	0 = Inactive 1 = FI X-5 2 = FI X-6		4648h	9800	enum
C5 Configurations\I/Os						
C5.1	Slot X					
C5.1.1	Slot X - Analog Inputs					
C5.1.1.1	AI1 Settings	Bit 0 = Detect Disconnection Bit 2 = Signal Config.		3BD6h	7126	2bit
C5.1.1.2	AI1 Filter	0.00 to 16.00 s	2	3BDAh	7130	16bit
C5.1.1.3	AI1 Gain	0.000 to 9.999	3	3BDEh	7134	16bit

Parameter	Description	Range of values	Decimal places	Index	Net Id	Size
C5.1.1.4	AI1 Offset	-100.00 to 100.00 %	2	3BE2h	7138	s16bit
C5.1.1.5	AI1 Dead Zone	0.00 to 100.00 %	2	3BE6h	7142	16bit
C5.1.1.6	AI2 Settings	Bit 0 = Detect Disconnection Bit 2 = Signal Config.		3BD7h	7127	2bit
C5.1.1.7	AI2 Filter	0.00 to 16.00 s	2	3BDBh	7131	16bit
C5.1.1.8	AI2 Gain	0.000 to 9.999	3	3BDFh	7135	16bit
C5.1.1.9	AI2 Offset	-100.00 to 100.00 %	2	3BE3h	7139	s16bit
C5.1.1.10	AI2 Dead Zone	0.00 to 100.00 %	2	3BE7h	7143	16bit
C5.1.2	Slot X - Analog Outputs					
C5.1.2.1	AO1 Signal Type	0 = 0 to 20 mA 1 = 4 to 20 mA 2 = 20 to 0 mA 3 = 20 to 4 mA 4 = 0 to 10 V 5 = 10 to 0 V		3C0Bh	7179	enum
C5.1.2.2	AO1 Gain	0.000 to 9.999	3	3C0Fh	7183	16bit
C5.1.2.3	AO1 Function	0 = Off (0 %) 1 = On (100 %) 2 = Speed Ref. 3 = Total Speed Ref. 4 = Real Speed 5 ... 6 = Not used 7 = Output Current 8 = Process Var. 9 = Not used 10 = Output Power 11 = PID Setpoint 12 = Not used 13 = Motor Torque 14 = SoftPLC 15 = PTC 16 = Motor lxt 17 = Encoder Speed 18 = Network 19 = Not used 20 = Torque Ref. 21 = Total Torque Ref.		3C13h	7187	enum
C5.1.2.4	AO1 Offset	-100.00 to 100.00 %	2	3C17h	7191	s16bit
C5.1.2.5	AO2 Signal Type	0 = 0 to 20 mA 1 = 4 to 20 mA 2 = 20 to 0 mA 3 = 20 to 4 mA 4 = 0 to 10 V 5 = 10 to 0 V		3C0Ch	7180	enum
C5.1.2.6	AO2 Gain	0.000 to 9.999	3	3C10h	7184	16bit
C5.1.2.7	AO2 Function			3C14h	7188	enum

Parameter	Description	Range of values	Decimal places	Index	Net Id	Size
		0 = Off (0 %) 1 = On (100 %) 2 = Speed Ref. 3 = Total Speed Ref. 4 = Real Speed 5 ... 6 = Not used 7 = Output Current 8 = Process Var. 9 = Not used 10 = Output Power 11 = PID Setpoint 12 = Not used 13 = Motor Torque 14 = SoftPLC 15 = PTC 16 = Motor lxt 17 = Encoder Speed 18 = Network 19 = Not used 20 = Torque Ref. 21 = Total Torque Ref.				
C5.1.2.8	AO2 Offset	-100.00 to 100.00 %	2	3C18h	7192	s16bit
C5.1.3	Slot X - Digital Inputs					
C5.1.3.4	DI5 Operation Mode			3C79h	7289	enum
		0 = Polling 1 = Not used 2 = Frequency 3 = Encoder				
C5.1.3.5	FI5 Min Frequency	0 to 32000 Hz	0	3C69h	7273	16bit
C5.1.3.6	FI5 Max Frequency	0 to 32000 Hz	0	3C67h	7271	16bit
C5.1.3.7	FI5 Gain	0.000 to 9.999	3	3C65h	7269	16bit
C5.1.3.8	FI5 Offset	-100.00 to 100.00 %	2	3C63h	7267	s16bit
C5.1.3.9	DI6 Operation Mode			3C7Ah	7290	enum
		0 = Polling 1 = Not used 2 = Frequency 3 = Encoder				
C5.1.3.10	FI6 Min Frequency	0 to 32000 Hz	0	3C6Ah	7274	16bit
C5.1.3.11	FI6 Max Frequency	0 to 32000 Hz	0	3C68h	7272	16bit
C5.1.3.12	FI6 Gain	0.000 to 9.999	3	3C66h	7270	16bit
C5.1.3.13	FI6 Offset	-100.00 to 100.00 %	2	3C64h	7268	s16bit
C5.1.4	Slot X - Digital Outputs					
C5.1.4.1	DO1 Operation Mode			3C7Dh	7293	enum
		0 = Polling 1 = Frequency				
C5.1.4.2	DO1 Function			3BF3h	7155	enum
		0 = Off 1 = On 2 = N* > Nx 3 = N > Nx				

Parameter	Description	Range of values	Decimal places	Index	Net Id	Size
		4 = N < Ny 5 = N = N* 6 ... 7 = Not used 8 = F > Fx 9 = Is > Ix 10 = Is < Ix 11 = Torque > Tx 12 = Torque < Tx 13 = Hours Enabled > Hx 14 ... 15 = Not used 16 = Local Mode 17 = Remote 1 Mode 18 = Remote 2 Mode 19 = Run 20 = Ready 21 = STO 22 = No Fault 23 = With Fault 24 = No Alarm 25 = No Fault and Alarm 26 = Network 27 = SoftPLC 28 = Forward Direction 29 = Ride-Through 30 = Pre-Charge OK				
C5.1.4.3	FO1 Function	0 = Off (0 %) 1 = On (100 %) 2 = Speed Ref. 3 = Total Speed Ref. 4 = Real Speed 5 ... 6 = Not used 7 = Output Current 8 = Process Var. 9 = Not used 10 = Output Power 11 = PID Setpoint 12 = Not used 13 = Motor Torque 14 = SoftPLC 15 = Not used 16 = Motor Ixt 17 = Encoder Speed 18 = Network 19 = Not used 20 = Torque Ref. 21 = Total Torque Ref.		3C6Bh	7275	enum
C5.1.4.4	FO1 Min Frequency	0 to 32000 Hz	0	3C73h	7283	16bit
C5.1.4.5	FO1 Max Frequency	0 to 32000 Hz	0	3C71h	7281	16bit
C5.1.4.6	FO1 Gain	0.000 to 9.999	3	3C6Fh	7279	16bit
C5.1.4.7	FO1 Offset	-100.00 to 100.00 %	2	3C6Dh	7277	s16bit

Parameter	Description	Range of values	Decimal places	Index	Net Id	Size
C5.1.4.8	DO2 Operation Mode	0 = Polling 1 = Frequency		3C7Eh	7294	enum
C5.1.4.9	DO2 Function	0 = Off 1 = On 2 = N* > Nx 3 = N > Nx 4 = N < Ny 5 = N = N* 6 ... 7 = Not used 8 = F > Fx 9 = Is > Ix 10 = Is < Ix 11 = Torque > Tx 12 = Torque < Tx 13 = Hours Enabled > Hx 14 ... 15 = Not used 16 = Local Mode 17 = Remote 1 Mode 18 = Remote 2 Mode 19 = Run 20 = Ready 21 = STO 22 = No Fault 23 = With Fault 24 = No Alarm 25 = No Fault and Alarm 26 = Network 27 = SoftPLC 28 = Forward Direction 29 = Ride-Through 30 = Pre-Charge OK		3BF4h	7156	enum
C5.1.4.10	FO2 Function	0 = Off (0 %) 1 = On (100 %) 2 = Speed Ref. 3 = Total Speed Ref. 4 = Real Speed 5 ... 6 = Not used 7 = Output Current 8 = Process Var. 9 = Not used 10 = Output Power 11 = PID Setpoint 12 = Not used 13 = Motor Torque 14 = SoftPLC 15 = Not used 16 = Motor Ixt 17 = Encoder Speed		3C6Ch	7276	enum

Parameter	Description	Range of values	Decimal places	Index	Net Id	Size
		18 = Network 19 = Not used 20 = Torque Ref. 21 = Total Torque Ref.				
C5.1.4.11	FO2 Min Frequency	0 to 32000 Hz	0	3C74h	7284	16bit
C5.1.4.12	FO2 Max Frequency	0 to 32000 Hz	0	3C72h	7282	16bit
C5.1.4.13	FO2 Gain	0.000 to 9.999	3	3C70h	7280	16bit
C5.1.4.14	FO2 Offset	-100.00 to 100.00 %	2	3C6Eh	7278	s16bit
C5.1.5	Slot X-Encoder					
C5.1.5.1	Number of Pulses	1 to 65535 ppr	0	3BD3h	7123	16bit
C5.2	Slot A					
C5.2.1	Slot A-Analog Inputs					
C5.2.1.1	AI1 Settings	Bit 0 = Detect Disconnection Bit 2 = Signal Config.		3D02h	7426	2bit
C5.2.1.2	AI1 Filter	0.00 to 16.00 s	2	3D06h	7430	16bit
C5.2.1.3	AI1 Gain	0.000 to 9.999	3	3D0Ah	7434	16bit
C5.2.1.4	AI1 Offset	-100.00 to 100.00 %	2	3D0Eh	7438	s16bit
C5.2.1.5	AI1 Dead Zone	0.00 to 100.00 %	2	3D12h	7442	16bit
C5.2.1.6	AI2 Settings	Bit 0 = Detect Disconnection Bit 2 = Signal Config.		3D03h	7427	2bit
C5.2.1.7	AI2 Filter	0.00 to 16.00 s	2	3D07h	7431	16bit
C5.2.1.8	AI2 Gain	0.000 to 9.999	3	3D0Bh	7435	16bit
C5.2.1.9	AI2 Offset	-100.00 to 100.00 %	2	3D0Fh	7439	s16bit
C5.2.1.10	AI2 Dead Zone	0.00 to 100.00 %	2	3D13h	7443	16bit
C5.2.1.11	AI3 Settings	Bit 0 = Detect Disconnection Bit 2 = Signal Config.		3D04h	7428	2bit
C5.2.1.12	AI3 Filter	0.00 to 16.00 s	2	3D08h	7432	16bit
C5.2.1.13	AI3 Gain	0.000 to 9.999	3	3D0Ch	7436	16bit
C5.2.1.14	AI3 Offset	-100.00 to 100.00 %	2	3D10h	7440	s16bit
C5.2.1.15	AI3 Dead Zone	0.00 to 100.00 %	2	3D14h	7444	16bit
C5.2.2	Slot A - Analog Outputs					
C5.2.2.1	AO1 Signal Type	0 = 0 to 20 mA 1 = 4 to 20 mA 2 = 20 to 0 mA 3 = 20 to 4 mA 4 = 0 to 10 V 5 = 10 to 0 V 6 ... 7 = Not used		3D37h	7479	enum
C5.2.2.2	AO1 Gain	0.000 to 9.999	3	3D3Bh	7483	16bit
C5.2.2.3	AO1 Function	0 = Off (0 %) 1 = On (100 %) 2 = Speed Ref. 3 = Total Speed Ref. 4 = Real Speed		3D3Fh	7487	enum

Parameter	Description	Range of values	Decimal places	Index	Net Id	Size
		5 ... 6 = Not used 7 = Output Current 8 = Process Var. 9 = Not used 10 = Output Power 11 = PID Setpoint 12 = Not used 13 = Motor Torque 14 = SoftPLC 15 = PTC 16 = Motor lxt 17 = Encoder Speed 18 = Network 19 = Not used 20 = Torque Ref. 21 = Total Torque Ref.				
C5.2.2.4	AO1 Offset	-100.00 to 100.00 %	2	3D43h	7491	s16bit
C5.2.2.5	AO2 Signal Type			3D38h	7480	enum
		0 = 0 to 20 mA 1 = 4 to 20 mA 2 = 20 to 0 mA 3 = 20 to 4 mA 4 = 0 to 10 V 5 = 10 to 0 V 6 ... 7 = Not used				
C5.2.2.6	AO2 Gain	0.000 to 9.999	3	3D3Ch	7484	16bit
C5.2.2.7	AO2 Function			3D40h	7488	enum
		0 = Off (0 %) 1 = On (100 %) 2 = Speed Ref. 3 = Total Speed Ref. 4 = Real Speed 5 ... 6 = Not used 7 = Output Current 8 = Process Var. 9 = Not used 10 = Output Power 11 = PID Setpoint 12 = Not used 13 = Motor Torque 14 = SoftPLC 15 = PTC 16 = Motor lxt 17 = Encoder Speed 18 = Network 19 = Not used 20 = Torque Ref. 21 = Total Torque Ref.				
C5.2.2.8	AO2 Offset	-100.00 to 100.00 %	2	3D44h	7492	s16bit
C5.2.4	Slot A - Digital Outputs					

Parameter	Description	Range of values	Decimal places	Index	Net Id	Size
C5.2.4.1	DO1 Function	0 = Off 1 = On 2 = N* > Nx 3 = N > Nx 4 = N < Ny 5 = N = N* 6 ... 7 = Not used 8 = F > Fx 9 = Is > lx 10 = Is < lx 11 = Torque > Tx 12 = Torque < Tx 13 = Hours Enabled > Hx 14 ... 15 = Not used 16 = Local Mode 17 = Remote 1 Mode 18 = Remote 2 Mode 19 = Run 20 = Ready 21 = STO 22 = No Fault 23 = With Fault 24 = No Alarm 25 = No Fault and Alarm 26 = Network 27 = SoftPLC 28 = Forward Direction 29 = Ride-Through 30 = Pre-Charge OK		3D1Fh	7455	enum
C5.2.4.2	DO2 Function	0 = Off 1 = On 2 = N* > Nx 3 = N > Nx 4 = N < Ny 5 = N = N* 6 ... 7 = Not used 8 = F > Fx 9 = Is > lx 10 = Is < lx 11 = Torque > Tx 12 = Torque < Tx 13 = Hours Enabled > Hx 14 ... 15 = Not used 16 = Local Mode 17 = Remote 1 Mode 18 = Remote 2 Mode 19 = Run 20 = Ready 21 = STO		3D20h	7456	enum

Parameter	Description	Range of values	Decimal places	Index	Net Id	Size
		22 = No Fault 23 = With Fault 24 = No Alarm 25 = No Fault and Alarm 26 = Network 27 = SoftPLC 28 = Forward Direction 29 = Ride-Through 30 = Pre-Charge OK				
C5.2.4.3	DO3 Function	0 = Off 1 = On 2 = N* > Nx 3 = N > Nx 4 = N < Ny 5 = N = N* 6 ... 7 = Not used 8 = F > Fx 9 = Is > Ix 10 = Is < Ix 11 = Torque > Tx 12 = Torque < Tx 13 = Hours Enabled > Hx 14 ... 15 = Not used 16 = Local Mode 17 = Remote 1 Mode 18 = Remote 2 Mode 19 = Run 20 = Ready 21 = STO 22 = No Fault 23 = With Fault 24 = No Alarm 25 = No Fault and Alarm 26 = Network 27 = SoftPLC 28 = Forward Direction 29 = Ride-Through 30 = Pre-Charge OK		3D21h	7457	enum
C5.2.4.4	DO4 Function	0 = Off 1 = On 2 = N* > Nx 3 = N > Nx 4 = N < Ny 5 = N = N* 6 ... 7 = Not used 8 = F > Fx 9 = Is > Ix 10 = Is < Ix 11 = Torque > Tx		3D22h	7458	enum

Parameter	Description	Range of values	Decimal places	Index	Net Id	Size
		12 = Torque < Tx 13 = Hours Enabled > Hx 14 ... 15 = Not used 16 = Local Mode 17 = Remote 1 Mode 18 = Remote 2 Mode 19 = Run 20 = Ready 21 = STO 22 = No Fault 23 = With Fault 24 = No Alarm 25 = No Fault and Alarm 26 = Network 27 = SoftPLC 28 = Forward Direction 29 = Ride-Through 30 = Pre-Charge OK				
C5.2.4.5	DO5 Function	0 = Off 1 = On 2 = N* > Nx 3 = N > Nx 4 = N < Ny 5 = N = N* 6 ... 7 = Not used 8 = F > Fx 9 = Is > Ix 10 = Is < Ix 11 = Torque > Tx 12 = Torque < Tx 13 = Hours Enabled > Hx 14 ... 15 = Not used 16 = Local Mode 17 = Remote 1 Mode 18 = Remote 2 Mode 19 = Run 20 = Ready 21 = STO 22 = No Fault 23 = With Fault 24 = No Alarm 25 = No Fault and Alarm 26 = Network 27 = SoftPLC 28 = Forward Direction 29 = Ride-Through 30 = Pre-Charge OK		3D23h	7459	enum
C5.2.4.6	DO6 Function	0 = Off 1 = On		3D24h	7460	enum

Parameter	Description	Range of values	Decimal places	Index	Net Id	Size
		2 = N* > Nx 3 = N > Nx 4 = N < Ny 5 = N = N* 6 ... 7 = Not used 8 = F > Fx 9 = Is > Ix 10 = Is < Ix 11 = Torque > Tx 12 = Torque < Tx 13 = Hours Enabled > Hx 14 ... 15 = Not used 16 = Local Mode 17 = Remote 1 Mode 18 = Remote 2 Mode 19 = Run 20 = Ready 21 = STO 22 = No Fault 23 = With Fault 24 = No Alarm 25 = No Fault and Alarm 26 = Network 27 = SoftPLC 28 = Forward Direction 29 = Ride-Through 30 = Pre-Charge OK				
C5.2.4.7	DO7 Function	0 = Off 1 = On 2 = N* > Nx 3 = N > Nx 4 = N < Ny 5 = N = N* 6 ... 7 = Not used 8 = F > Fx 9 = Is > Ix 10 = Is < Ix 11 = Torque > Tx 12 = Torque < Tx 13 = Hours Enabled > Hx 14 ... 15 = Not used 16 = Local Mode 17 = Remote 1 Mode 18 = Remote 2 Mode 19 = Run 20 = Ready 21 = STO 22 = No Fault 23 = With Fault 24 = No Alarm		3D25h	7461	enum

Parameter	Description	Range of values	Decimal places	Index	Net Id	Size
		25 = No Fault and Alarm 26 = Network 27 = SoftPLC 28 = Forward Direction 29 = Ride-Through 30 = Pre-Charge OK				
C5.2.4.8	DO8 Function	0 = Off 1 = On 2 = N* > Nx 3 = N > Nx 4 = N < Ny 5 = N = N* 6 ... 7 = Not used 8 = F > Fx 9 = Is > Ix 10 = Is < Ix 11 = Torque > Tx 12 = Torque < Tx 13 = Hours Enabled > Hx 14 ... 15 = Not used 16 = Local Mode 17 = Remote 1 Mode 18 = Remote 2 Mode 19 = Run 20 = Ready 21 = STO 22 = No Fault 23 = With Fault 24 = No Alarm 25 = No Fault and Alarm 26 = Network 27 = SoftPLC 28 = Forward Direction 29 = Ride-Through 30 = Pre-Charge OK		3D26h	7462	enum
C5.2.5	Slot A-Encoder					
C5.2.5.1	Number of Pulses	1 to 65535 ppr	0	3CFFh	7423	16bit
C5.2.5.2	Settings	Bit 0 = Broken Cable A Bit 2 = Broken Cable B Bit 4 = Broken Cable Z Bit 6 = Search Zero Bit 7 = Signal Direction		3D00h	7424	5bit
C5.2.6	Slot A-Temperatures					
C5.2.6.1	Sensor Type	0 = PT100 1 = PT1000 2 = Single PTC 3 = Triple PTC		3D16h	7446	enum

Parameter	Description	Range of values	Decimal places	Index	Net Id	Size
C5.2.6.2	Overtemperature Config.	Bit 0 = S1 Sensor F/A Bit 2 = S2 Sensor F/A Bit 4 = S3 Sensor F/A Bit 6 = S4 Sensor F/A Bit 8 = S5 Sensor F/A Bit 10 = S6 Sensor F/A		3D17h	7447	6bit
C5.2.6.3	Measurement Error Config.	Bit 0 = S1 Sensor F/A Bit 2 = S2 Sensor F/A Bit 4 = S3 Sensor F/A Bit 6 = S4 Sensor F/A Bit 8 = S5 Sensor F/A Bit 10 = S6 Sensor F/A		3D18h	7448	6bit
C5.2.6.4	Sensor 1 Temp. Setpoint	-100.0 to 250.0 °C	1	3D19h	7449	s16bit
C5.2.6.5	Sensor 2 Temp. Setpoint	-100.0 to 250.0 °C	1	3D1Ah	7450	s16bit
C5.2.6.6	Sensor 3 Temp. Setpoint	-100.0 to 250.0 °C	1	3D1Bh	7451	s16bit
C5.2.6.7	Sensor 4 Temp. Setpoint	-100.0 to 250.0 °C	1	3D1Ch	7452	s16bit
C5.2.6.8	Sensor 5 Temp. Setpoint	-100.0 to 250.0 °C	1	3D1Dh	7453	s16bit
C5.2.6.9	Sensor 6 Temp. Setpoint	-100.0 to 250.0 °C	1	3D1Eh	7454	s16bit
C5.3	Slot B					
C5.3.1	Slot B-Analog Inputs					
C5.3.1.1	AI1 Settings	Bit 0 = Detect Disconnection Bit 2 = Signal Config.		3E2Eh	7726	2bit
C5.3.1.2	AI1 Filter	0.00 to 16.00 s	2	3E32h	7730	16bit
C5.3.1.3	AI1 Gain	0.000 to 9.999	3	3E36h	7734	16bit
C5.3.1.4	AI1 Offset	-100.00 to 100.00 %	2	3E3Ah	7738	s16bit
C5.3.1.5	AI1 Dead Zone	0.00 to 100.00 %	2	3E3Eh	7742	16bit
C5.3.1.6	AI2 Settings	Bit 0 = Detect Disconnection Bit 2 = Signal Config.		3E2Fh	7727	2bit
C5.3.1.7	AI2 Filter	0.00 to 16.00 s	2	3E33h	7731	16bit
C5.3.1.8	AI2 Gain	0.000 to 9.999	3	3E37h	7735	16bit
C5.3.1.9	AI2 Offset	-100.00 to 100.00 %	2	3E3Bh	7739	s16bit
C5.3.1.10	AI2 Dead Zone	0.00 to 100.00 %	2	3E3Fh	7743	16bit
C5.3.1.11	AI3 Settings	Bit 0 = Detect Disconnection Bit 2 = Signal Config.		3E30h	7728	2bit
C5.3.1.12	AI3 Filter	0.00 to 16.00 s	2	3E34h	7732	16bit
C5.3.1.13	AI3 Gain	0.000 to 9.999	3	3E38h	7736	16bit
C5.3.1.14	AI3 Offset	-100.00 to 100.00 %	2	3E3Ch	7740	s16bit
C5.3.1.15	AI3 Dead Zone	0.00 to 100.00 %	2	3E40h	7744	16bit
C5.3.2	Slot B-Analog Outputs					
C5.3.2.1	AO1 Signal Type	0 = 0 to 20 mA 1 = 4 to 20 mA 2 = 20 to 0 mA 3 = 20 to 4 mA		3E63h	7779	enum

Parameter	Description	Range of values	Decimal places	Index	Net Id	Size
C5.3.2.2	AO1 Gain	4 = 0 to 10 V 5 = 10 to 0 V 6 ... 7 = Not used 0.000 to 9.999	3	3E67h	7783	16bit
C5.3.2.3	AO1 Function	0 = Off (0 %) 1 = On (100 %) 2 = Speed Ref. 3 = Total Speed Ref. 4 = Real Speed 5 ... 6 = Not used 7 = Output Current 8 = Process Var. 9 = Not used 10 = Output Power 11 = PID Setpoint 12 = Not used 13 = Motor Torque 14 = SoftPLC 15 = PTC 16 = Motor lxt 17 = Encoder Speed 18 = Network 19 = Not used 20 = Torque Ref. 21 = Total Torque Ref.		3E6Bh	7787	enum
C5.3.2.4	AO1 Offset	-100.00 to 100.00 %	2	3E6Fh	7791	s16bit
C5.3.2.5	AO2 Signal Type	0 = 0 to 20 mA 1 = 4 to 20 mA 2 = 20 to 0 mA 3 = 20 to 4 mA 4 = 0 to 10 V 5 = 10 to 0 V 6 ... 7 = Not used		3E64h	7780	enum
C5.3.2.6	AO2 Gain	0.000 to 9.999	3	3E68h	7784	16bit
C5.3.2.7	AO2 Function	0 = Off (0 %) 1 = On (100 %) 2 = Speed Ref. 3 = Total Speed Ref. 4 = Real Speed 5 ... 6 = Not used 7 = Output Current 8 = Process Var. 9 = Not used 10 = Output Power 11 = PID Setpoint 12 = Not used 13 = Motor Torque 14 = SoftPLC		3E6Ch	7788	enum

Parameter	Description	Range of values	Decimal places	Index	Net Id	Size
C5.3.2.8	AO2 Offset	15 = PTC 16 = Motor lxt 17 = Encoder Speed 18 = Network 19 = Not used 20 = Torque Ref. 21 = Total Torque Ref. -100.00 to 100.00 %	2	3E70h	7792	s16bit
C5.3.4	Slot B-Digital Outputs					
C5.3.4.1	DO1 Function	0 = Off 1 = On 2 = N* > Nx 3 = N > Nx 4 = N < Ny 5 = N = N* 6 ... 7 = Not used 8 = F > Fx 9 = Is > Ix 10 = Is < Ix 11 = Torque > Tx 12 = Torque < Tx 13 = Hours Enabled > Hx 14 ... 15 = Not used 16 = Local Mode 17 = Remote 1 Mode 18 = Remote 2 Mode 19 = Run 20 = Ready 21 = STO 22 = No Fault 23 = With Fault 24 = No Alarm 25 = No Fault and Alarm 26 = Network 27 = SoftPLC 28 = Forward Direction 29 = Ride-Through 30 = Pre-Charge OK		3E4Bh	7755	enum
C5.3.4.2	DO2 Function	0 = Off 1 = On 2 = N* > Nx 3 = N > Nx 4 = N < Ny 5 = N = N* 6 ... 7 = Not used 8 = F > Fx 9 = Is > Ix 10 = Is < Ix 11 = Torque > Tx		3E4Ch	7756	enum

Parameter	Description	Range of values	Decimal places	Index	Net Id	Size
		12 = Torque < Tx 13 = Hours Enabled > Hx 14 ... 15 = Not used 16 = Local Mode 17 = Remote 1 Mode 18 = Remote 2 Mode 19 = Run 20 = Ready 21 = STO 22 = No Fault 23 = With Fault 24 = No Alarm 25 = No Fault and Alarm 26 = Network 27 = SoftPLC 28 = Forward Direction 29 = Ride-Through 30 = Pre-Charge OK				
C5.3.4.3	DO3 Function	0 = Off 1 = On 2 = N* > Nx 3 = N > Nx 4 = N < Ny 5 = N = N* 6 ... 7 = Not used 8 = F > Fx 9 = Is > Ix 10 = Is < Ix 11 = Torque > Tx 12 = Torque < Tx 13 = Hours Enabled > Hx 14 ... 15 = Not used 16 = Local Mode 17 = Remote 1 Mode 18 = Remote 2 Mode 19 = Run 20 = Ready 21 = STO 22 = No Fault 23 = With Fault 24 = No Alarm 25 = No Fault and Alarm 26 = Network 27 = SoftPLC 28 = Forward Direction 29 = Ride-Through 30 = Pre-Charge OK		3E4Dh	7757	enum
C5.3.4.4	DO4 Function	0 = Off 1 = On		3E4Eh	7758	enum

Parameter	Description	Range of values	Decimal places	Index	Net Id	Size
		2 = N* > Nx 3 = N > Nx 4 = N < Ny 5 = N = N* 6 ... 7 = Not used 8 = F > Fx 9 = Is > Ix 10 = Is < Ix 11 = Torque > Tx 12 = Torque < Tx 13 = Hours Enabled > Hx 14 ... 15 = Not used 16 = Local Mode 17 = Remote 1 Mode 18 = Remote 2 Mode 19 = Run 20 = Ready 21 = STO 22 = No Fault 23 = With Fault 24 = No Alarm 25 = No Fault and Alarm 26 = Network 27 = SoftPLC 28 = Forward Direction 29 = Ride-Through 30 = Pre-Charge OK				
C5.3.4.5	DO5 Function	0 = Off 1 = On 2 = N* > Nx 3 = N > Nx 4 = N < Ny 5 = N = N* 6 ... 7 = Not used 8 = F > Fx 9 = Is > Ix 10 = Is < Ix 11 = Torque > Tx 12 = Torque < Tx 13 = Hours Enabled > Hx 14 ... 15 = Not used 16 = Local Mode 17 = Remote 1 Mode 18 = Remote 2 Mode 19 = Run 20 = Ready 21 = STO 22 = No Fault 23 = With Fault 24 = No Alarm		3E4Fh	7759	enum

Parameter	Description	Range of values	Decimal places	Index	Net Id	Size
		25 = No Fault and Alarm 26 = Network 27 = SoftPLC 28 = Forward Direction 29 = Ride-Through 30 = Pre-Charge OK				
C5.3.4.6	DO6 Function	0 = Off 1 = On 2 = N* > Nx 3 = N > Nx 4 = N < Ny 5 = N = N* 6 ... 7 = Not used 8 = F > Fx 9 = Is > Ix 10 = Is < Ix 11 = Torque > Tx 12 = Torque < Tx 13 = Hours Enabled > Hx 14 ... 15 = Not used 16 = Local Mode 17 = Remote 1 Mode 18 = Remote 2 Mode 19 = Run 20 = Ready 21 = STO 22 = No Fault 23 = With Fault 24 = No Alarm 25 = No Fault and Alarm 26 = Network 27 = SoftPLC 28 = Forward Direction 29 = Ride-Through 30 = Pre-Charge OK		3E50h	7760	enum
C5.3.4.7	DO7 Function	0 = Off 1 = On 2 = N* > Nx 3 = N > Nx 4 = N < Ny 5 = N = N* 6 ... 7 = Not used 8 = F > Fx 9 = Is > Ix 10 = Is < Ix 11 = Torque > Tx 12 = Torque < Tx 13 = Hours Enabled > Hx 14 ... 15 = Not used		3E51h	7761	enum

Parameter	Description	Range of values	Decimal places	Index	Net Id	Size
		16 = Local Mode 17 = Remote 1 Mode 18 = Remote 2 Mode 19 = Run 20 = Ready 21 = STO 22 = No Fault 23 = With Fault 24 = No Alarm 25 = No Fault and Alarm 26 = Network 27 = SoftPLC 28 = Forward Direction 29 = Ride-Through 30 = Pre-Charge OK				
C5.3.4.8	DO8 Function	0 = Off 1 = On 2 = N* > Nx 3 = N > Nx 4 = N < Ny 5 = N = N* 6 ... 7 = Not used 8 = F > Fx 9 = Is > Ix 10 = Is < Ix 11 = Torque > Tx 12 = Torque < Tx 13 = Hours Enabled > Hx 14 ... 15 = Not used 16 = Local Mode 17 = Remote 1 Mode 18 = Remote 2 Mode 19 = Run 20 = Ready 21 = STO 22 = No Fault 23 = With Fault 24 = No Alarm 25 = No Fault and Alarm 26 = Network 27 = SoftPLC 28 = Forward Direction 29 = Ride-Through 30 = Pre-Charge OK		3E52h	7762	enum
C5.3.5	Slot B-Encoder					
C5.3.5.1	Number of Pulses	1 to 65535 ppr	0	3E2Bh	7723	16bit
C5.3.5.2	Settings	Bit 0 = Broken Cable A Bit 2 = Broken Cable B Bit 4 = Broken Cable Z		3E2Ch	7724	5bit

Parameter	Description	Range of values	Decimal places	Index	Net Id	Size
		Bit 6 = Search Zero Bit 7 = Signal Direction				
C5.3.6	Slot B-Temperatures					
C5.3.6.1	Sensor Type	0 = PT100 1 = PT1000 2 = Single PTC 3 = Triple PTC		3E42h	7746	enum
C5.3.6.2	Overtemperature Config.	Bit 0 = S1 Sensor F/A Bit 2 = S2 Sensor F/A Bit 4 = S3 Sensor F/A Bit 6 = S4 Sensor F/A Bit 8 = S5 Sensor F/A Bit 10 = S6 Sensor F/A		3E43h	7747	6bit
C5.3.6.3	Broken Cable Config.	Bit 0 = S1 Sensor F/A Bit 2 = S2 Sensor F/A Bit 4 = S3 Sensor F/A Bit 6 = S4 Sensor F/A Bit 8 = S5 Sensor F/A Bit 10 = S6 Sensor F/A		3E44h	7748	6bit
C5.3.6.4	Sensor 1 Temp. Setpoint	-100.0 to 250.0 °C	1	3E45h	7749	s16bit
C5.3.6.5	Sensor 2 Temp. Setpoint	-100.0 to 250.0 °C	1	3E46h	7750	s16bit
C5.3.6.6	Sensor 3 Temp. Setpoint	-100.0 to 250.0 °C	1	3E47h	7751	s16bit
C5.3.6.7	Sensor 4 Temp. Setpoint	-100.0 to 250.0 °C	1	3E48h	7752	s16bit
C5.3.6.8	Sensor 5 Temp. Setpoint	-100.0 to 250.0 °C	1	3E49h	7753	s16bit
C5.3.6.9	Sensor 6 Temp. Setpoint	-100.0 to 250.0 °C	1	3E4Ah	7754	s16bit
C5.4	Slot C					
C5.4.1	Slot C-Analog Inputs					
C5.4.1.1	AI1 Settings	Bit 0 = Detect Disconnection Bit 2 = Signal Config.		3F5Ah	8026	2bit
C5.4.1.2	AI1 Filter	0.00 to 16.00 s	2	3F5Eh	8030	16bit
C5.4.1.3	AI1 Gain	0.000 to 9.999	3	3F62h	8034	16bit
C5.4.1.4	AI1 Offset	-100.00 to 100.00 %	2	3F66h	8038	s16bit
C5.4.1.5	AI1 Dead Zone	0.00 to 100.00 %	2	3F6Ah	8042	16bit
C5.4.1.6	AI2 Settings	Bit 0 = Detect Disconnection Bit 2 = Signal Config.		3F5Bh	8027	2bit
C5.4.1.7	AI2 Filter	0.00 to 16.00 s	2	3F5Fh	8031	16bit
C5.4.1.8	AI2 Gain	0.000 to 9.999	3	3F63h	8035	16bit
C5.4.1.9	AI2 Offset	-100.00 to 100.00 %	2	3F67h	8039	s16bit
C5.4.1.10	AI2 Dead Zone	0.00 to 100.00 %	2	3F6Bh	8043	16bit
C5.4.1.11	AI3 Settings	Bit 0 = Detect Disconnection Bit 2 = Signal Config.		3F5Ch	8028	2bit
C5.4.1.12	AI3 Filter	0.00 to 16.00 s	2	3F60h	8032	16bit
C5.4.1.13	AI3 Gain	0.000 to 9.999	3	3F64h	8036	16bit



Parameter	Description	Range of values	Decimal places	Index	Net Id	Size
C5.4.1.14	AI3 Offset	-100.00 to 100.00 %	2	3F68h	8040	s16bit
C5.4.1.15	AI3 Dead Zone	0.00 to 100.00 %	2	3F6Ch	8044	16bit
C5.4.2	Slot C-Analog Outputs					
C5.4.2.1	AO1 Signal Type	0 = 0 to 20 mA 1 = 4 to 20 mA 2 = 20 to 0 mA 3 = 20 to 4 mA 4 = 0 to 10 V 5 = 10 to 0 V 6 ... 7 = Not used		3F8Fh	8079	enum
C5.4.2.2	AO1 Gain	0.000 to 9.999	3	3F93h	8083	16bit
C5.4.2.3	AO1 Function	0 = Off (0 %) 1 = On (100 %) 2 = Speed Ref. 3 = Total Speed Ref. 4 = Real Speed 5 ... 6 = Not used 7 = Output Current 8 = Process Var. 9 = Not used 10 = Output Power 11 = PID Setpoint 12 = Not used 13 = Motor Torque 14 = SoftPLC 15 = PTC 16 = Motor Ixt 17 = Encoder Speed 18 = Network 19 = Not used 20 = Torque Ref. 21 = Total Torque Ref.		3F97h	8087	enum
C5.4.2.4	AO1 Offset	-100.00 to 100.00 %	2	3F9Bh	8091	s16bit
C5.4.2.5	AO2 Signal Type	0 = 0 to 20 mA 1 = 4 to 20 mA 2 = 20 to 0 mA 3 = 20 to 4 mA 4 = 0 to 10 V 5 = 10 to 0 V 6 ... 7 = Not used		3F90h	8080	enum
C5.4.2.6	AO2 Gain	0.000 to 9.999	3	3F94h	8084	16bit
C5.4.2.7	AO2 Function	0 = Off (0 %) 1 = On (100 %) 2 = Speed Ref. 3 = Total Speed Ref. 4 = Real Speed		3F98h	8088	enum

Parameter	Description	Range of values	Decimal places	Index	Net Id	Size
		5 ... 6 = Not used 7 = Output Current 8 = Process Var. 9 = Not used 10 = Output Power 11 = PID Setpoint 12 = Not used 13 = Motor Torque 14 = SoftPLC 15 = PTC 16 = Motor lxt 17 = Encoder Speed 18 = Network 19 = Not used 20 = Torque Ref. 21 = Total Torque Ref.				
C5.4.2.8	AO2 Offset	-100.00 to 100.00 %	2	3F9Ch	8092	s16bit
C5.4.4	Slot C-Digital Outputs					
C5.4.4.1	DO1 Function	0 = Off 1 = On 2 = N* > Nx 3 = N > Nx 4 = N < Ny 5 = N = N* 6 ... 7 = Not used 8 = F > Fx 9 = Is > lx 10 = Is < lx 11 = Torque > Tx 12 = Torque < Tx 13 = Hours Enabled > Hx 14 ... 15 = Not used 16 = Local Mode 17 = Remote 1 Mode 18 = Remote 2 Mode 19 = Run 20 = Ready 21 = STO 22 = No Fault 23 = With Fault 24 = No Alarm 25 = No Fault and Alarm 26 = Network 27 = SoftPLC 28 = Forward Direction 29 = Ride-Through 30 = Pre-Charge OK		3F77h	8055	enum
C5.4.4.2	DO2 Function	0 = Off 1 = On		3F78h	8056	enum

Parameter	Description	Range of values	Decimal places	Index	Net Id	Size
		2 = N* > Nx 3 = N > Nx 4 = N < Ny 5 = N = N* 6 ... 7 = Not used 8 = F > Fx 9 = Is > Ix 10 = Is < Ix 11 = Torque > Tx 12 = Torque < Tx 13 = Hours Enabled > Hx 14 ... 15 = Not used 16 = Local Mode 17 = Remote 1 Mode 18 = Remote 2 Mode 19 = Run 20 = Ready 21 = STO 22 = No Fault 23 = With Fault 24 = No Alarm 25 = No Fault and Alarm 26 = Network 27 = SoftPLC 28 = Forward Direction 29 = Ride-Through 30 = Pre-Charge OK				
C5.4.4.3	DO3 Function	0 = Off 1 = On 2 = N* > Nx 3 = N > Nx 4 = N < Ny 5 = N = N* 6 ... 7 = Not used 8 = F > Fx 9 = Is > Ix 10 = Is < Ix 11 = Torque > Tx 12 = Torque < Tx 13 = Hours Enabled > Hx 14 ... 15 = Not used 16 = Local Mode 17 = Remote 1 Mode 18 = Remote 2 Mode 19 = Run 20 = Ready 21 = STO 22 = No Fault 23 = With Fault 24 = No Alarm		3F79h	8057	enum

Parameter	Description	Range of values	Decimal places	Index	Net Id	Size
		25 = No Fault and Alarm 26 = Network 27 = SoftPLC 28 = Forward Direction 29 = Ride-Through 30 = Pre-Charge OK				
C5.4.4.4	DO4 Function	0 = Off 1 = On 2 = N* > Nx 3 = N > Nx 4 = N < Ny 5 = N = N* 6 ... 7 = Not used 8 = F > Fx 9 = Is > Ix 10 = Is < Ix 11 = Torque > Tx 12 = Torque < Tx 13 = Hours Enabled > Hx 14 ... 15 = Not used 16 = Local Mode 17 = Remote 1 Mode 18 = Remote 2 Mode 19 = Run 20 = Ready 21 = STO 22 = No Fault 23 = With Fault 24 = No Alarm 25 = No Fault and Alarm 26 = Network 27 = SoftPLC 28 = Forward Direction 29 = Ride-Through 30 = Pre-Charge OK		3F7Ah	8058	enum
C5.4.4.5	DO5 Function	0 = Off 1 = On 2 = N* > Nx 3 = N > Nx 4 = N < Ny 5 = N = N* 6 ... 7 = Not used 8 = F > Fx 9 = Is > Ix 10 = Is < Ix 11 = Torque > Tx 12 = Torque < Tx 13 = Hours Enabled > Hx 14 ... 15 = Not used		3F7Bh	8059	enum

Parameter	Description	Range of values	Decimal places	Index	Net Id	Size
		16 = Local Mode 17 = Remote 1 Mode 18 = Remote 2 Mode 19 = Run 20 = Ready 21 = STO 22 = No Fault 23 = With Fault 24 = No Alarm 25 = No Fault and Alarm 26 = Network 27 = SoftPLC 28 = Forward Direction 29 = Ride-Through 30 = Pre-Charge OK				
C5.4.4.6	DO6 Function	0 = Off 1 = On 2 = N* > Nx 3 = N > Nx 4 = N < Ny 5 = N = N* 6 ... 7 = Not used 8 = F > Fx 9 = Is > Ix 10 = Is < Ix 11 = Torque > Tx 12 = Torque < Tx 13 = Hours Enabled > Hx 14 ... 15 = Not used 16 = Local Mode 17 = Remote 1 Mode 18 = Remote 2 Mode 19 = Run 20 = Ready 21 = STO 22 = No Fault 23 = With Fault 24 = No Alarm 25 = No Fault and Alarm 26 = Network 27 = SoftPLC 28 = Forward Direction 29 = Ride-Through 30 = Pre-Charge OK		3F7Ch	8060	enum
C5.4.4.7	DO7 Function	0 = Off 1 = On 2 = N* > Nx 3 = N > Nx 4 = N < Ny		3F7Dh	8061	enum

Parameter	Description	Range of values	Decimal places	Index	Net Id	Size
		5 = N = N* 6 ... 7 = Not used 8 = F > Fx 9 = Is > lx 10 = Is < lx 11 = Torque > Tx 12 = Torque < Tx 13 = Hours Enabled > Hx 14 ... 15 = Not used 16 = Local Mode 17 = Remote 1 Mode 18 = Remote 2 Mode 19 = Run 20 = Ready 21 = STO 22 = No Fault 23 = With Fault 24 = No Alarm 25 = No Fault and Alarm 26 = Network 27 = SoftPLC 28 = Forward Direction 29 = Ride-Through 30 = Pre-Charge OK				
C5.4.4.8	DO8 Function	0 = Off 1 = On 2 = N* > Nx 3 = N > Nx 4 = N < Ny 5 = N = N* 6 ... 7 = Not used 8 = F > Fx 9 = Is > lx 10 = Is < lx 11 = Torque > Tx 12 = Torque < Tx 13 = Hours Enabled > Hx 14 ... 15 = Not used 16 = Local Mode 17 = Remote 1 Mode 18 = Remote 2 Mode 19 = Run 20 = Ready 21 = STO 22 = No Fault 23 = With Fault 24 = No Alarm 25 = No Fault and Alarm 26 = Network 27 = SoftPLC		3F7Eh	8062	enum

Parameter	Description	Range of values	Decimal places	Index	Net Id	Size
		28 = Forward Direction 29 = Ride-Through 30 = Pre-Charge OK				
C5.4.5	Slot C-Encoder					
C5.4.5.1	Number of Pulses	1 to 65535 ppr	0	3F57h	8023	16bit
C5.4.5.2	Settings	Bit 0 = Broken Cable A Bit 2 = Broken Cable B Bit 4 = Broken Cable Z Bit 6 = Search Zero Bit 7 = Signal Direction		3F58h	8024	5bit
C5.4.6	Slot C-Temperatures					
C5.4.6.1	Sensor Type	0 = PT100 1 = PT1000 2 = Single PTC 3 = Triple PTC		3F6Eh	8046	enum
C5.4.6.2	Overtemperature Config.	Bit 0 = S1 Sensor F/A Bit 2 = S2 Sensor F/A Bit 4 = S3 Sensor F/A Bit 6 = S4 Sensor F/A Bit 8 = S5 Sensor F/A Bit 10 = S6 Sensor F/A		3F6Fh	8047	6bit
C5.4.6.3	Broken Cable Config.	Bit 0 = S1 Sensor F/A Bit 2 = S2 Sensor F/A Bit 4 = S3 Sensor F/A Bit 6 = S4 Sensor F/A Bit 8 = S5 Sensor F/A Bit 10 = S6 Sensor F/A		3F70h	8048	6bit
C5.4.6.4	Sensor 1 Temp. Setpoint	-100.0 to 250.0 °C	1	3F71h	8049	s16bit
C5.4.6.5	Sensor 2 Temp. Setpoint	-100.0 to 250.0 °C	1	3F72h	8050	s16bit
C5.4.6.6	Sensor 3 Temp. Setpoint	-100.0 to 250.0 °C	1	3F73h	8051	s16bit
C5.4.6.7	Sensor 4 Temp. Setpoint	-100.0 to 250.0 °C	1	3F74h	8052	s16bit
C5.4.6.8	Sensor 5 Temp. Setpoint	-100.0 to 250.0 °C	1	3F75h	8053	s16bit
C5.4.6.9	Sensor 6 Temp. Setpoint	-100.0 to 250.0 °C	1	3F76h	8054	s16bit
C5.5	Slot D					
C5.5.1	Slot D-Analog Inputs					
C5.5.1.1	AI1 Settings	Bit 0 = Detect Disconnection Bit 2 = Signal Config.		4086h	8326	2bit
C5.5.1.2	AI1 Filter	0.00 to 16.00 s	2	408Ah	8330	16bit
C5.5.1.3	AI1 Gain	0.000 to 9.999	3	408Eh	8334	16bit
C5.5.1.4	AI1 Offset	-100.00 to 100.00 %	2	4092h	8338	s16bit
C5.5.1.5	AI1 Dead Zone	0.00 to 100.00 %	2	4096h	8342	16bit
C5.5.1.6	AI2 Settings	Bit 0 = Detect Disconnection Bit 2 = Signal Config.		4087h	8327	2bit

Parameter	Description	Range of values	Decimal places	Index	Net Id	Size
C5.5.1.7	AI2 Filter	0.00 to 16.00 s	2	408Bh	8331	16bit
C5.5.1.8	AI2 Gain	0.000 to 9.999	3	408Fh	8335	16bit
C5.5.1.9	AI2 Offset	-100.00 to 100.00 %	2	4093h	8339	s16bit
C5.5.1.10	AI2 Dead Zone	0.00 to 100.00 %	2	4097h	8343	16bit
C5.5.1.11	AI3 Settings	Bit 0 = Detect Disconnection Bit 2 = Signal Config.		4088h	8328	2bit
C5.5.1.12	AI3 Filter	0.00 to 16.00 s	2	408Ch	8332	16bit
C5.5.1.13	AI3 Gain	0.000 to 9.999	3	4090h	8336	16bit
C5.5.1.14	AI3 Offset	-100.00 to 100.00 %	2	4094h	8340	s16bit
C5.5.1.15	AI3 Dead Zone	0.00 to 100.00 %	2	4098h	8344	16bit
C5.5.2	Slot D-Analog Outputs					
C5.5.2.1	AO1 Signal Type	0 = 0 to 20 mA 1 = 4 to 20 mA 2 = 20 to 0 mA 3 = 20 to 4 mA 4 = 0 to 10 V 5 = 10 to 0 V 6 ... 7 = Not used		40BBh	8379	enum
C5.5.2.2	AO1 Gain	0.000 to 9.999	3	40BFh	8383	16bit
C5.5.2.3	AO1 Function	0 = Off (0 %) 1 = On (100 %) 2 = Speed Ref. 3 = Total Speed Ref. 4 = Real Speed 5 ... 6 = Not used 7 = Output Current 8 = Process Var. 9 = Not used 10 = Output Power 11 = PID Setpoint 12 = Not used 13 = Motor Torque 14 = SoftPLC 15 = PTC 16 = Motor lxt 17 = Encoder Speed 18 = Network 19 = Not used 20 = Torque Ref. 21 = Total Torque Ref.		40C3h	8387	enum
C5.5.2.4	AO1 Offset	-100.00 to 100.00 %	2	40C7h	8391	s16bit
C5.5.2.5	AO2 Signal Type	0 = 0 to 20 mA 1 = 4 to 20 mA 2 = 20 to 0 mA 3 = 20 to 4 mA 4 = 0 to 10 V		40BCh	8380	enum

Parameter	Description	Range of values	Decimal places	Index	Net Id	Size
C5.5.2.6	AO2 Gain	5 = 10 to 0 V 6 ... 7 = Not used 0.000 to 9.999	3	40C0h	8384	16bit
C5.5.2.7	AO2 Function	0 = Off (0 %) 1 = On (100 %) 2 = Speed Ref. 3 = Total Speed Ref. 4 = Real Speed 5 ... 6 = Not used 7 = Output Current 8 = Process Var. 9 = Not used 10 = Output Power 11 = PID Setpoint 12 = Not used 13 = Motor Torque 14 = SoftPLC 15 = PTC 16 = Motor lxt 17 = Encoder Speed 18 = Network 19 = Not used 20 = Torque Ref. 21 = Total Torque Ref.		40C4h	8388	enum
C5.5.2.8	AO2 Offset	21 = Total Torque Ref. -100.00 to 100.00 %	2	40C8h	8392	s16bit
C5.5.4	Slot D-Digital Outputs					
C5.5.4.1	DO1 Function	0 = Off 1 = On 2 = N* > Nx 3 = N > Nx 4 = N < Ny 5 = N = N* 6 ... 7 = Not used 8 = F > Fx 9 = Is > Ix 10 = Is < Ix 11 = Torque > Tx 12 = Torque < Tx 13 = Hours Enabled > Hx 14 ... 15 = Not used 16 = Local Mode 17 = Remote 1 Mode 18 = Remote 2 Mode 19 = Run 20 = Ready 21 = STO 22 = No Fault 23 = With Fault 24 = No Alarm		40A3h	8355	enum

Parameter	Description	Range of values	Decimal places	Index	Net Id	Size
		25 = No Fault and Alarm 26 = Network 27 = SoftPLC 28 = Forward Direction 29 = Ride-Through 30 = Pre-Charge OK				
C5.5.4.2	DO2 Function	0 = Off 1 = On 2 = N* > Nx 3 = N > Nx 4 = N < Ny 5 = N = N* 6 ... 7 = Not used 8 = F > Fx 9 = Is > Ix 10 = Is < Ix 11 = Torque > Tx 12 = Torque < Tx 13 = Hours Enabled > Hx 14 ... 15 = Not used 16 = Local Mode 17 = Remote 1 Mode 18 = Remote 2 Mode 19 = Run 20 = Ready 21 = STO 22 = No Fault 23 = With Fault 24 = No Alarm 25 = No Fault and Alarm 26 = Network 27 = SoftPLC 28 = Forward Direction 29 = Ride-Through 30 = Pre-Charge OK		40A4h	8356	enum
C5.5.4.3	DO3 Function	0 = Off 1 = On 2 = N* > Nx 3 = N > Nx 4 = N < Ny 5 = N = N* 6 ... 7 = Not used 8 = F > Fx 9 = Is > Ix 10 = Is < Ix 11 = Torque > Tx 12 = Torque < Tx 13 = Hours Enabled > Hx 14 ... 15 = Not used		40A5h	8357	enum

Parameter	Description	Range of values	Decimal places	Index	Net Id	Size
		16 = Local Mode 17 = Remote 1 Mode 18 = Remote 2 Mode 19 = Run 20 = Ready 21 = STO 22 = No Fault 23 = With Fault 24 = No Alarm 25 = No Fault and Alarm 26 = Network 27 = SoftPLC 28 = Forward Direction 29 = Ride-Through 30 = Pre-Charge OK				
C5.5.4.4	DO4 Function	0 = Off 1 = On 2 = N* > Nx 3 = N > Nx 4 = N < Ny 5 = N = N* 6 ... 7 = Not used 8 = F > Fx 9 = Is > Ix 10 = Is < Ix 11 = Torque > Tx 12 = Torque < Tx 13 = Hours Enabled > Hx 14 ... 15 = Not used 16 = Local Mode 17 = Remote 1 Mode 18 = Remote 2 Mode 19 = Run 20 = Ready 21 = STO 22 = No Fault 23 = With Fault 24 = No Alarm 25 = No Fault and Alarm 26 = Network 27 = SoftPLC 28 = Forward Direction 29 = Ride-Through 30 = Pre-Charge OK		40A6h	8358	enum
C5.5.4.5	DO5 Function	0 = Off 1 = On 2 = N* > Nx 3 = N > Nx 4 = N < Ny		40A7h	8359	enum

Parameter	Description	Range of values	Decimal places	Index	Net Id	Size
		5 = N = N* 6 ... 7 = Not used 8 = F > Fx 9 = Is > lx 10 = Is < lx 11 = Torque > Tx 12 = Torque < Tx 13 = Hours Enabled > Hx 14 ... 15 = Not used 16 = Local Mode 17 = Remote 1 Mode 18 = Remote 2 Mode 19 = Run 20 = Ready 21 = STO 22 = No Fault 23 = With Fault 24 = No Alarm 25 = No Fault and Alarm 26 = Network 27 = SoftPLC 28 = Forward Direction 29 = Ride-Through 30 = Pre-Charge OK				
C5.5.4.6	DO6 Function	0 = Off 1 = On 2 = N* > Nx 3 = N > Nx 4 = N < Ny 5 = N = N* 6 ... 7 = Not used 8 = F > Fx 9 = Is > lx 10 = Is < lx 11 = Torque > Tx 12 = Torque < Tx 13 = Hours Enabled > Hx 14 ... 15 = Not used 16 = Local Mode 17 = Remote 1 Mode 18 = Remote 2 Mode 19 = Run 20 = Ready 21 = STO 22 = No Fault 23 = With Fault 24 = No Alarm 25 = No Fault and Alarm 26 = Network 27 = SoftPLC		40A8h	8360	enum

Parameter	Description	Range of values	Decimal places	Index	Net Id	Size
C5.5.4.7	DO7 Function	28 = Forward Direction 29 = Ride-Through 30 = Pre-Charge OK 0 = Off 1 = On 2 = N* > Nx 3 = N > Nx 4 = N < Ny 5 = N = N* 6 ... 7 = Not used 8 = F > Fx 9 = Is > lx 10 = Is < lx 11 = Torque > Tx 12 = Torque < Tx 13 = Hours Enabled > Hx 14 ... 15 = Not used 16 = Local Mode 17 = Remote 1 Mode 18 = Remote 2 Mode 19 = Run 20 = Ready 21 = STO 22 = No Fault 23 = With Fault 24 = No Alarm 25 = No Fault and Alarm 26 = Network 27 = SoftPLC 28 = Forward Direction 29 = Ride-Through 30 = Pre-Charge OK		40A9h	8361	enum
C5.5.4.8	DO8 Function	0 = Off 1 = On 2 = N* > Nx 3 = N > Nx 4 = N < Ny 5 = N = N* 6 ... 7 = Not used 8 = F > Fx 9 = Is > lx 10 = Is < lx 11 = Torque > Tx 12 = Torque < Tx 13 = Hours Enabled > Hx 14 ... 15 = Not used 16 = Local Mode 17 = Remote 1 Mode 18 = Remote 2 Mode		40AAh	8362	enum

Parameter	Description	Range of values	Decimal places	Index	Net Id	Size
		19 = Run 20 = Ready 21 = STO 22 = No Fault 23 = With Fault 24 = No Alarm 25 = No Fault and Alarm 26 = Network 27 = SoftPLC 28 = Forward Direction 29 = Ride-Through 30 = Pre-Charge OK				
C5.5.5	Slot D-Encoder					
C5.5.5.1	Number of Pulses	1 to 65535 ppr	0	4083h	8323	16bit
C5.5.5.2	Settings	Bit 0 = Broken Cable A Bit 2 = Broken Cable B Bit 4 = Broken Cable Z Bit 6 = Search Zero Bit 7 = Signal Direction		4084h	8324	5bit
C5.5.6	Slot D-Temperatures					
C5.5.6.1	Sensor Type	0 = PT100 1 = PT1000 2 = Single PTC 3 = Triple PTC		409Ah	8346	enum
C5.5.6.2	Overtemperature Config.	Bit 0 = S1 Sensor F/A Bit 2 = S2 Sensor F/A Bit 4 = S3 Sensor F/A Bit 6 = S4 Sensor F/A Bit 8 = S5 Sensor F/A Bit 10 = S6 Sensor F/A		409Bh	8347	6bit
C5.5.6.3	Broken Cable Config.	Bit 0 = S1 Sensor F/A Bit 2 = S2 Sensor F/A Bit 4 = S3 Sensor F/A Bit 6 = S4 Sensor F/A Bit 8 = S5 Sensor F/A Bit 10 = S6 Sensor F/A		409Ch	8348	6bit
C5.5.6.4	Sensor 1 Temp. Setpoint	-100.0 to 250.0 °C	1	409Dh	8349	s16bit
C5.5.6.5	Sensor 2 Temp. Setpoint	-100.0 to 250.0 °C	1	409Eh	8350	s16bit
C5.5.6.6	Sensor 3 Temp. Setpoint	-100.0 to 250.0 °C	1	409Fh	8351	s16bit
C5.5.6.7	Sensor 4 Temp. Setpoint	-100.0 to 250.0 °C	1	40A0h	8352	s16bit
C5.5.6.8	Sensor 5 Temp. Setpoint	-100.0 to 250.0 °C	1	40A1h	8353	s16bit
C5.5.6.9	Sensor 6 Temp. Setpoint	-100.0 to 250.0 °C	1	40A2h	8354	s16bit
C5.6	Slot E					
C5.6.1	Slot E-Analog Inputs					
C5.6.1.1	AI1 Settings			41B2h	8626	2bit

Parameter	Description	Range of values	Decimal places	Index	Net Id	Size
		Bit 0 = Detect Disconnection Bit 2 = Signal Config.				
C5.6.1.2	AI1 Filter	0.00 to 16.00 s	2	41B6h	8630	16bit
C5.6.1.3	AI1 Gain	0.000 to 9.999	3	41BAh	8634	16bit
C5.6.1.4	AI1 Offset	-100.00 to 100.00 %	2	41BEh	8638	s16bit
C5.6.1.5	AI1 Dead Zone	0.00 to 100.00 %	2	41C2h	8642	16bit
C5.6.1.6	AI2 Settings			41B3h	8627	2bit
		Bit 0 = Detect Disconnection Bit 2 = Signal Config.				
C5.6.1.7	AI2 Filter	0.00 to 16.00 s	2	41B7h	8631	16bit
C5.6.1.8	AI2 Gain	0.000 to 9.999	3	41BBh	8635	16bit
C5.6.1.9	AI2 Offset	-100.00 to 100.00 %	2	41BFh	8639	s16bit
C5.6.1.10	AI2 Dead Zone	0.00 to 100.00 %	2	41C3h	8643	16bit
C5.6.1.11	AI3 Settings			41B4h	8628	2bit
		Bit 0 = Detect Disconnection Bit 2 = Signal Config.				
C5.6.1.12	AI3 Filter	0.00 to 16.00 s	2	41B8h	8632	16bit
C5.6.1.13	AI3 Gain	0.000 to 9.999	3	41BCh	8636	16bit
C5.6.1.14	AI3 Offset	-100.00 to 100.00 %	2	41C0h	8640	s16bit
C5.6.1.15	AI3 Dead Zone	0.00 to 100.00 %	2	41C4h	8644	16bit
C5.6.2	Slot E-Analog Outputs					
C5.6.2.1	AO1 Signal Type	0 = 0 to 20 mA 1 = 4 to 20 mA 2 = 20 to 0 mA 3 = 20 to 4 mA 4 = 0 to 10 V 5 = 10 to 0 V 6 ... 7 = Not used		41E7h	8679	enum
C5.6.2.2	AO1 Gain	0.000 to 9.999	3	41EBh	8683	16bit
C5.6.2.3	AO1 Function	0 = Off (0 %) 1 = On (100 %) 2 = Speed Ref. 3 = Total Speed Ref. 4 = Real Speed 5 ... 6 = Not used 7 = Output Current 8 = Process Var. 9 = Not used 10 = Output Power 11 = PID Setpoint 12 = Not used 13 = Motor Torque 14 = SoftPLC 15 = PTC 16 = Motor lxt 17 = Encoder Speed 18 = Network 19 = Not used		41EFh	8687	enum

Parameter	Description	Range of values	Decimal places	Index	Net Id	Size
C5.6.2.4	AO1 Offset	20 = Torque Ref. 21 = Total Torque Ref.				
C5.6.2.5	AO2 Signal Type	-100.00 to 100.00 %	2	41F3h	8691	s16bit
				41E8h	8680	enum
		0 = 0 to 20 mA 1 = 4 to 20 mA 2 = 20 to 0 mA 3 = 20 to 4 mA 4 = 0 to 10 V 5 = 10 to 0 V 6 ... 7 = Not used				
C5.6.2.6	AO2 Gain	0.000 to 9.999	3	41ECh	8684	16bit
C5.6.2.7	AO2 Function			41F0h	8688	enum
		0 = Off (0 %) 1 = On (100 %) 2 = Speed Ref. 3 = Total Speed Ref. 4 = Real Speed 5 ... 6 = Not used 7 = Output Current 8 = Process Var. 9 = Not used 10 = Output Power 11 = PID Setpoint 12 = Not used 13 = Motor Torque 14 = SoftPLC 15 = PTC 16 = Motor lxt 17 = Encoder Speed 18 = Network 19 = Not used 20 = Torque Ref. 21 = Total Torque Ref.				
C5.6.2.8	AO2 Offset	-100.00 to 100.00 %	2	41F4h	8692	s16bit
C5.6.4	Slot E-Digital Outputs					
C5.6.4.1	DO1 Function			41CFh	8655	enum
		0 = Off 1 = On 2 = N* > Nx 3 = N > Nx 4 = N < Ny 5 = N = N* 6 ... 7 = Not used 8 = F > Fx 9 = Is > lx 10 = Is < lx 11 = Torque > Tx 12 = Torque < Tx 13 = Hours Enabled > Hx				

Parameter	Description	Range of values	Decimal places	Index	Net Id	Size
		14 ... 15 = Not used 16 = Local Mode 17 = Remote 1 Mode 18 = Remote 2 Mode 19 = Run 20 = Ready 21 = STO 22 = No Fault 23 = With Fault 24 = No Alarm 25 = No Fault and Alarm 26 = Network 27 = SoftPLC 28 = Forward Direction 29 = Ride-Through 30 = Pre-Charge OK				
C5.6.4.2	DO2 Function	0 = Off 1 = On 2 = N* > Nx 3 = N > Nx 4 = N < Ny 5 = N = N* 6 ... 7 = Not used 8 = F > Fx 9 = Is > lx 10 = Is < lx 11 = Torque > Tx 12 = Torque < Tx 13 = Hours Enabled > Hx 14 ... 15 = Not used 16 = Local Mode 17 = Remote 1 Mode 18 = Remote 2 Mode 19 = Run 20 = Ready 21 = STO 22 = No Fault 23 = With Fault 24 = No Alarm 25 = No Fault and Alarm 26 = Network 27 = SoftPLC 28 = Forward Direction 29 = Ride-Through 30 = Pre-Charge OK		41D0h	8656	enum
C5.6.4.3	DO3 Function	0 = Off 1 = On 2 = N* > Nx 3 = N > Nx		41D1h	8657	enum

Parameter	Description	Range of values	Decimal places	Index	Net Id	Size
		4 = N < Ny 5 = N = N* 6 ... 7 = Not used 8 = F > Fx 9 = Is > lx 10 = Is < lx 11 = Torque > Tx 12 = Torque < Tx 13 = Hours Enabled > Hx 14 ... 15 = Not used 16 = Local Mode 17 = Remote 1 Mode 18 = Remote 2 Mode 19 = Run 20 = Ready 21 = STO 22 = No Fault 23 = With Fault 24 = No Alarm 25 = No Fault and Alarm 26 = Network 27 = SoftPLC 28 = Forward Direction 29 = Ride-Through 30 = Pre-Charge OK				
C5.6.4.4	DO4 Function	0 = Off 1 = On 2 = N* > Nx 3 = N > Nx 4 = N < Ny 5 = N = N* 6 ... 7 = Not used 8 = F > Fx 9 = Is > lx 10 = Is < lx 11 = Torque > Tx 12 = Torque < Tx 13 = Hours Enabled > Hx 14 ... 15 = Not used 16 = Local Mode 17 = Remote 1 Mode 18 = Remote 2 Mode 19 = Run 20 = Ready 21 = STO 22 = No Fault 23 = With Fault 24 = No Alarm 25 = No Fault and Alarm 26 = Network		41D2h	8658	enum

Parameter	Description	Range of values	Decimal places	Index	Net Id	Size
C5.6.4.5	DO5 Function	27 = SoftPLC 28 = Forward Direction 29 = Ride-Through 30 = Pre-Charge OK 0 = Off 1 = On 2 = N* > Nx 3 = N > Nx 4 = N < Ny 5 = N = N* 6 ... 7 = Not used 8 = F > Fx 9 = Is > Ix 10 = Is < Ix 11 = Torque > Tx 12 = Torque < Tx 13 = Hours Enabled > Hx 14 ... 15 = Not used 16 = Local Mode 17 = Remote 1 Mode 18 = Remote 2 Mode 19 = Run 20 = Ready 21 = STO 22 = No Fault 23 = With Fault 24 = No Alarm 25 = No Fault and Alarm 26 = Network 27 = SoftPLC 28 = Forward Direction 29 = Ride-Through 30 = Pre-Charge OK		41D3h	8659	enum
C5.6.4.6	DO6 Function	0 = Off 1 = On 2 = N* > Nx 3 = N > Nx 4 = N < Ny 5 = N = N* 6 ... 7 = Not used 8 = F > Fx 9 = Is > Ix 10 = Is < Ix 11 = Torque > Tx 12 = Torque < Tx 13 = Hours Enabled > Hx 14 ... 15 = Not used 16 = Local Mode 17 = Remote 1 Mode		41D4h	8660	enum

Parameter	Description	Range of values	Decimal places	Index	Net Id	Size
		18 = Remote 2 Mode 19 = Run 20 = Ready 21 = STO 22 = No Fault 23 = With Fault 24 = No Alarm 25 = No Fault and Alarm 26 = Network 27 = SoftPLC 28 = Forward Direction 29 = Ride-Through 30 = Pre-Charge OK				
C5.6.4.7	DO7 Function	0 = Off 1 = On 2 = N* > Nx 3 = N > Nx 4 = N < Ny 5 = N = N* 6 ... 7 = Not used 8 = F > Fx 9 = Is > lx 10 = Is < lx 11 = Torque > Tx 12 = Torque < Tx 13 = Hours Enabled > Hx 14 ... 15 = Not used 16 = Local Mode 17 = Remote 1 Mode 18 = Remote 2 Mode 19 = Run 20 = Ready 21 = STO 22 = No Fault 23 = With Fault 24 = No Alarm 25 = No Fault and Alarm 26 = Network 27 = SoftPLC 28 = Forward Direction 29 = Ride-Through 30 = Pre-Charge OK		41D5h	8661	enum
C5.6.4.8	DO8 Function	0 = Off 1 = On 2 = N* > Nx 3 = N > Nx 4 = N < Ny 5 = N = N* 6 ... 7 = Not used		41D6h	8662	enum

Parameter	Description	Range of values	Decimal places	Index	Net Id	Size
		8 = F > Fx 9 = Is > Ix 10 = Is < Ix 11 = Torque > Tx 12 = Torque < Tx 13 = Hours Enabled > Hx 14 ... 15 = Not used 16 = Local Mode 17 = Remote 1 Mode 18 = Remote 2 Mode 19 = Run 20 = Ready 21 = STO 22 = No Fault 23 = With Fault 24 = No Alarm 25 = No Fault and Alarm 26 = Network 27 = SoftPLC 28 = Forward Direction 29 = Ride-Through 30 = Pre-Charge OK				
C5.6.5	Slot E-Encoder					
C5.6.5.1	Number of Pulses	1 to 65535 ppr	0	41AFh	8623	16bit
C5.6.5.2	Settings	Bit 0 = Broken Cable A Bit 2 = Broken Cable B Bit 4 = Broken Cable Z Bit 6 = Search Zero Bit 7 = Signal Direction		41B0h	8624	5bit
C5.6.6	Slot E-Temperatures					
C5.6.6.1	Sensor Type	0 = PT100 1 = PT1000 2 = Single PTC 3 = Triple PTC		41C6h	8646	enum
C5.6.6.2	Overtemperature Config.	Bit 0 = S1 Sensor F/A Bit 2 = S2 Sensor F/A Bit 4 = S3 Sensor F/A Bit 6 = S4 Sensor F/A Bit 8 = S5 Sensor F/A Bit 10 = S6 Sensor F/A		41C7h	8647	6bit
C5.6.6.3	Broken Cable Config.	Bit 0 = S1 Sensor F/A Bit 2 = S2 Sensor F/A Bit 4 = S3 Sensor F/A Bit 6 = S4 Sensor F/A Bit 8 = S5 Sensor F/A Bit 10 = S6 Sensor F/A		41C8h	8648	6bit

Parameter	Description	Range of values	Decimal places	Index	Net Id	Size
C5.6.6.4	Sensor 1 Temp. Setpoint	-100.0 to 250.0 °C	1	41C9h	8649	s16bit
C5.6.6.5	Sensor 2 Temp. Setpoint	-100.0 to 250.0 °C	1	41CAh	8650	s16bit
C5.6.6.6	Sensor 3 Temp. Setpoint	-100.0 to 250.0 °C	1	41CBh	8651	s16bit
C5.6.6.7	Sensor 4 Temp. Setpoint	-100.0 to 250.0 °C	1	41CCh	8652	s16bit
C5.6.6.8	Sensor 5 Temp. Setpoint	-100.0 to 250.0 °C	1	41CDh	8653	s16bit
C5.6.6.9	Sensor 6 Temp. Setpoint	-100.0 to 250.0 °C	1	41CEh	8654	s16bit
C5.7	Slot F					
C5.7.1	Slot F-Analog Inputs					
C5.7.1.1	AI1 Settings	Bit 0 = Detect Disconnection Bit 2 = Signal Config.		42DEh	8926	2bit
C5.7.1.2	AI1 Filter	0.00 to 16.00 s	2	42E2h	8930	16bit
C5.7.1.3	AI1 Gain	0.000 to 9.999	3	42E6h	8934	16bit
C5.7.1.4	AI1 Offset	-100.00 to 100.00 %	2	42EAh	8938	s16bit
C5.7.1.5	AI1 Dead Zone	0.00 to 100.00 %	2	42EEh	8942	16bit
C5.7.1.6	AI2 Settings	Bit 0 = Detect Disconnection Bit 2 = Signal Config.		42DFh	8927	2bit
C5.7.1.7	AI2 Filter	0.00 to 16.00 s	2	42E3h	8931	16bit
C5.7.1.8	AI2 Gain	0.000 to 9.999	3	42E7h	8935	16bit
C5.7.1.9	AI2 Offset	-100.00 to 100.00 %	2	42EBh	8939	s16bit
C5.7.1.10	AI2 Dead Zone	0.00 to 100.00 %	2	42EFh	8943	16bit
C5.7.1.11	AI3 Settings	Bit 0 = Detect Disconnection Bit 2 = Signal Config.		42E0h	8928	2bit
C5.7.1.12	AI3 Filter	0.00 to 16.00 s	2	42E4h	8932	16bit
C5.7.1.13	AI3 Gain	0.000 to 9.999	3	42E8h	8936	16bit
C5.7.1.14	AI3 Offset	-100.00 to 100.00 %	2	42ECh	8940	s16bit
C5.7.1.15	AI3 Dead Zone	0.00 to 100.00 %	2	42F0h	8944	16bit
C5.7.2	Slot F-Analog Outputs					
C5.7.2.1	AO1 Signal Type	0 = 0 to 20 mA 1 = 4 to 20 mA 2 = 20 to 0 mA 3 = 20 to 4 mA 4 = 0 to 10 V 5 = 10 to 0 V 6 ... 7 = Not used		4313h	8979	enum
C5.7.2.2	AO1 Gain	0.000 to 9.999	3	4317h	8983	16bit
C5.7.2.3	AO1 Function	0 = Off (0 %) 1 = On (100 %) 2 = Speed Ref. 3 = Total Speed Ref. 4 = Real Speed 5 ... 6 = Not used 7 = Output Current 8 = Process Var. 9 = Not used 10 = Output Power		431Bh	8987	enum

Parameter	Description	Range of values	Decimal places	Index	Net Id	Size
		11 = PID Setpoint 12 = Not used 13 = Motor Torque 14 = SoftPLC 15 = PTC 16 = Motor lxt 17 = Encoder Speed 18 = Network 19 = Not used 20 = Torque Ref. 21 = Total Torque Ref.				
C5.7.2.4	AO1 Offset	-100.00 to 100.00 %	2	431Fh	8991	s16bit
C5.7.2.5	AO2 Signal Type			4314h	8980	enum
		0 = 0 to 20 mA 1 = 4 to 20 mA 2 = 20 to 0 mA 3 = 20 to 4 mA 4 = 0 to 10 V 5 = 10 to 0 V 6 ... 7 = Not used				
C5.7.2.6	AO2 Gain	0.000 to 9.999	3	4318h	8984	16bit
C5.7.2.7	AO2 Function			431Ch	8988	enum
		0 = Off (0 %) 1 = On (100 %) 2 = Speed Ref. 3 = Total Speed Ref. 4 = Real Speed 5 ... 6 = Not used 7 = Output Current 8 = Process Var. 9 = Not used 10 = Output Power 11 = PID Setpoint 12 = Not used 13 = Motor Torque 14 = SoftPLC 15 = PTC 16 = Motor lxt 17 = Encoder Speed 18 = Network 19 = Not used 20 = Torque Ref. 21 = Total Torque Ref.				
C5.7.2.8	AO2 Offset	-100.00 to 100.00 %	2	4320h	8992	s16bit
C5.7.4	Slot F-Digital Outputs					
C5.7.4.1	DO1 Function			42FBh	8955	enum
		0 = Off 1 = On 2 = N* > Nx 3 = N > Nx				

Parameter	Description	Range of values	Decimal places	Index	Net Id	Size
		4 = N < Ny 5 = N = N* 6 ... 7 = Not used 8 = F > Fx 9 = Is > lx 10 = Is < lx 11 = Torque > Tx 12 = Torque < Tx 13 = Hours Enabled > Hx 14 ... 15 = Not used 16 = Local Mode 17 = Remote 1 Mode 18 = Remote 2 Mode 19 = Run 20 = Ready 21 = STO 22 = No Fault 23 = With Fault 24 = No Alarm 25 = No Fault and Alarm 26 = Network 27 = SoftPLC 28 = Forward Direction 29 = Ride-Through 30 = Pre-Charge OK				
C5.7.4.2	DO2 Function	0 = Off 1 = On 2 = N* > Nx 3 = N > Nx 4 = N < Ny 5 = N = N* 6 ... 7 = Not used 8 = F > Fx 9 = Is > lx 10 = Is < lx 11 = Torque > Tx 12 = Torque < Tx 13 = Hours Enabled > Hx 14 ... 15 = Not used 16 = Local Mode 17 = Remote 1 Mode 18 = Remote 2 Mode 19 = Run 20 = Ready 21 = STO 22 = No Fault 23 = With Fault 24 = No Alarm 25 = No Fault and Alarm 26 = Network		42FCh	8956	enum

Parameter	Description	Range of values	Decimal places	Index	Net Id	Size
C5.7.4.3	DO3 Function	27 = SoftPLC 28 = Forward Direction 29 = Ride-Through 30 = Pre-Charge OK 0 = Off 1 = On 2 = N* > Nx 3 = N > Nx 4 = N < Ny 5 = N = N* 6 ... 7 = Not used 8 = F > Fx 9 = Is > Ix 10 = Is < Ix 11 = Torque > Tx 12 = Torque < Tx 13 = Hours Enabled > Hx 14 ... 15 = Not used 16 = Local Mode 17 = Remote 1 Mode 18 = Remote 2 Mode 19 = Run 20 = Ready 21 = STO 22 = No Fault 23 = With Fault 24 = No Alarm 25 = No Fault and Alarm 26 = Network 27 = SoftPLC 28 = Forward Direction 29 = Ride-Through 30 = Pre-Charge OK		42FDh	8957	enum
C5.7.4.4	DO4 Function	0 = Off 1 = On 2 = N* > Nx 3 = N > Nx 4 = N < Ny 5 = N = N* 6 ... 7 = Not used 8 = F > Fx 9 = Is > Ix 10 = Is < Ix 11 = Torque > Tx 12 = Torque < Tx 13 = Hours Enabled > Hx 14 ... 15 = Not used 16 = Local Mode 17 = Remote 1 Mode		42FEh	8958	enum

Parameter	Description	Range of values	Decimal places	Index	Net Id	Size
		18 = Remote 2 Mode 19 = Run 20 = Ready 21 = STO 22 = No Fault 23 = With Fault 24 = No Alarm 25 = No Fault and Alarm 26 = Network 27 = SoftPLC 28 = Forward Direction 29 = Ride-Through 30 = Pre-Charge OK				
C5.7.4.5	DO5 Function	0 = Off 1 = On 2 = N* > Nx 3 = N > Nx 4 = N < Ny 5 = N = N* 6 ... 7 = Not used 8 = F > Fx 9 = Is > lx 10 = Is < lx 11 = Torque > Tx 12 = Torque < Tx 13 = Hours Enabled > Hx 14 ... 15 = Not used 16 = Local Mode 17 = Remote 1 Mode 18 = Remote 2 Mode 19 = Run 20 = Ready 21 = STO 22 = No Fault 23 = With Fault 24 = No Alarm 25 = No Fault and Alarm 26 = Network 27 = SoftPLC 28 = Forward Direction 29 = Ride-Through 30 = Pre-Charge OK		42FFh	8959	enum
C5.7.4.6	DO6 Function	0 = Off 1 = On 2 = N* > Nx 3 = N > Nx 4 = N < Ny 5 = N = N* 6 ... 7 = Not used		4300h	8960	enum

Parameter	Description	Range of values	Decimal places	Index	Net Id	Size
		8 = F > Fx 9 = Is > lx 10 = Is < lx 11 = Torque > Tx 12 = Torque < Tx 13 = Hours Enabled > Hx 14 ... 15 = Not used 16 = Local Mode 17 = Remote 1 Mode 18 = Remote 2 Mode 19 = Run 20 = Ready 21 = STO 22 = No Fault 23 = With Fault 24 = No Alarm 25 = No Fault and Alarm 26 = Network 27 = SoftPLC 28 = Forward Direction 29 = Ride-Through 30 = Pre-Charge OK				
C5.7.4.7	DO7 Function	0 = Off 1 = On 2 = N* > Nx 3 = N > Nx 4 = N < Ny 5 = N = N* 6 ... 7 = Not used 8 = F > Fx 9 = Is > lx 10 = Is < lx 11 = Torque > Tx 12 = Torque < Tx 13 = Hours Enabled > Hx 14 ... 15 = Not used 16 = Local Mode 17 = Remote 1 Mode 18 = Remote 2 Mode 19 = Run 20 = Ready 21 = STO 22 = No Fault 23 = With Fault 24 = No Alarm 25 = No Fault and Alarm 26 = Network 27 = SoftPLC 28 = Forward Direction 29 = Ride-Through		4301h	8961	enum

Parameter	Description	Range of values	Decimal places	Index	Net Id	Size
C5.7.4.8	DO8 Function	30 = Pre-Charge OK 0 = Off 1 = On 2 = N* > Nx 3 = N > Nx 4 = N < Ny 5 = N = N* 6 ... 7 = Not used 8 = F > Fx 9 = Is > lx 10 = Is < lx 11 = Torque > Tx 12 = Torque < Tx 13 = Hours Enabled > Hx 14 ... 15 = Not used 16 = Local Mode 17 = Remote 1 Mode 18 = Remote 2 Mode 19 = Run 20 = Ready 21 = STO 22 = No Fault 23 = With Fault 24 = No Alarm 25 = No Fault and Alarm 26 = Network 27 = SoftPLC 28 = Forward Direction 29 = Ride-Through 30 = Pre-Charge OK		4302h	8962	enum
C5.7.5	Slot F-Encoder					
C5.7.5.1	Number of Pulses	1 to 65535 ppr	0	42DBh	8923	16bit
C5.7.5.2	Settings	Bit 0 = Broken Cable A Bit 2 = Broken Cable B Bit 4 = Broken Cable Z Bit 6 = Search Zero Bit 7 = Signal Direction		42DCh	8924	5bit
C5.7.6	Slot F-Temperatures					
C5.7.6.1	Sensor Type	0 = PT100 1 = PT1000 2 = Single PTC 3 = Triple PTC		42F2h	8946	enum
C5.7.6.2	Overtemperature Config.	Bit 0 = S1 Sensor F/A Bit 2 = S2 Sensor F/A Bit 4 = S3 Sensor F/A Bit 6 = S4 Sensor F/A		42F3h	8947	6bit

Parameter	Description	Range of values	Decimal places	Index	Net Id	Size
C5.7.6.3	Broken Cable Config.	Bit 8 = S5 Sensor F/A Bit 10 = S6 Sensor F/A		42F4h	8948	6bit
C5.7.6.4	Sensor 1 Temp. Setpoint	-100.0 to 250.0 °C	1	42F5h	8949	s16bit
C5.7.6.5	Sensor 2 Temp. Setpoint	-100.0 to 250.0 °C	1	42F6h	8950	s16bit
C5.7.6.6	Sensor 3 Temp. Setpoint	-100.0 to 250.0 °C	1	42F7h	8951	s16bit
C5.7.6.7	Sensor 4 Temp. Setpoint	-100.0 to 250.0 °C	1	42F8h	8952	s16bit
C5.7.6.8	Sensor 5 Temp. Setpoint	-100.0 to 250.0 °C	1	42F9h	8953	s16bit
C5.7.6.9	Sensor 6 Temp. Setpoint	-100.0 to 250.0 °C	1	42FAh	8954	s16bit
C5.8	Slot G					
C5.8.1	Slot G-Analog Inputs					
C5.8.1.1	AI1 Settings	Bit 0 = Detect Disconnection Bit 2 = Signal Config.		440Ah	9226	2bit
C5.8.1.2	AI1 Filter	0.00 to 16.00 s	2	440Eh	9230	16bit
C5.8.1.3	AI1 Gain	0.000 to 9.999	3	4412h	9234	16bit
C5.8.1.4	AI1 Offset	-100.00 to 100.00 %	2	4416h	9238	s16bit
C5.8.1.5	AI1 Dead Zone	0.00 to 100.00 %	2	441Ah	9242	16bit
C5.8.1.6	AI2 Settings	Bit 0 = Detect Disconnection Bit 2 = Signal Config.		440Bh	9227	2bit
C5.8.1.7	AI2 Filter	0.00 to 16.00 s	2	440Fh	9231	16bit
C5.8.1.8	AI2 Gain	0.000 to 9.999	3	4413h	9235	16bit
C5.8.1.9	AI2 Offset	-100.00 to 100.00 %	2	4417h	9239	s16bit
C5.8.1.10	AI2 Dead Zone	0.00 to 100.00 %	2	441Bh	9243	16bit
C5.8.1.11	AI3 Settings	Bit 0 = Detect Disconnection Bit 2 = Signal Config.		440Ch	9228	2bit
C5.8.1.12	AI3 Filter	0.00 to 16.00 s	2	4410h	9232	16bit
C5.8.1.13	AI3 Gain	0.000 to 9.999	3	4414h	9236	16bit
C5.8.1.14	AI3 Offset	-100.00 to 100.00 %	2	4418h	9240	s16bit
C5.8.1.15	AI3 Dead Zone	0.00 to 100.00 %	2	441Ch	9244	16bit
C5.8.2	Slot G-Analog Outputs					
C5.8.2.1	AO1 Signal Type	0 = 0 to 20 mA 1 = 4 to 20 mA 2 = 20 to 0 mA 3 = 20 to 4 mA 4 = 0 to 10 V 5 = 10 to 0 V 6 ... 7 = Not used		443Fh	9279	enum
C5.8.2.2	AO1 Gain	0.000 to 9.999	3	4443h	9283	16bit
C5.8.2.3	AO1 Function			4447h	9287	enum

Parameter	Description	Range of values	Decimal places	Index	Net Id	Size
		0 = Off (0 %) 1 = On (100 %) 2 = Speed Ref. 3 = Total Speed Ref. 4 = Real Speed 5 ... 6 = Not used 7 = Output Current 8 = Process Var. 9 = Not used 10 = Output Power 11 = PID Setpoint 12 = Not used 13 = Motor Torque 14 = SoftPLC 15 = PTC 16 = Motor lxt 17 = Encoder Speed 18 = Network 19 = Not used 20 = Torque Ref. 21 = Total Torque Ref.				
C5.8.2.4	AO1 Offset	-100.00 to 100.00 %	2	444Bh	9291	s16bit
C5.8.2.5	AO2 Signal Type			4440h	9280	enum
		0 = 0 to 20 mA 1 = 4 to 20 mA 2 = 20 to 0 mA 3 = 20 to 4 mA 4 = 0 to 10 V 5 = 10 to 0 V 6 ... 7 = Not used				
C5.8.2.6	AO2 Gain	0.000 to 9.999	3	4444h	9284	16bit
C5.8.2.7	AO2 Function			4448h	9288	enum
		0 = Off (0 %) 1 = On (100 %) 2 = Speed Ref. 3 = Total Speed Ref. 4 = Real Speed 5 ... 6 = Not used 7 = Output Current 8 = Process Var. 9 = Not used 10 = Output Power 11 = PID Setpoint 12 = Not used 13 = Motor Torque 14 = SoftPLC 15 = PTC 16 = Motor lxt 17 = Encoder Speed 18 = Network 19 = Not used				

Parameter	Description	Range of values	Decimal places	Index	Net Id	Size
C5.8.2.8	AO2 Offset	20 = Torque Ref. 21 = Total Torque Ref. -100.00 to 100.00 %	2	444Ch	9292	s16bit
C5.8.4	Slot G-Digital Outputs					
C5.8.4.1	DO1 Function	0 = Off 1 = On 2 = N* > Nx 3 = N > Nx 4 = N < Ny 5 = N = N* 6 ... 7 = Not used 8 = F > Fx 9 = Is > lx 10 = Is < lx 11 = Torque > Tx 12 = Torque < Tx 13 = Hours Enabled > Hx 14 ... 15 = Not used 16 = Local Mode 17 = Remote 1 Mode 18 = Remote 2 Mode 19 = Run 20 = Ready 21 = STO 22 = No Fault 23 = With Fault 24 = No Alarm 25 = No Fault and Alarm 26 = Network 27 = SoftPLC 28 = Forward Direction 29 = Ride-Through 30 = Pre-Charge OK		4427h	9255	enum
C5.8.4.2	DO2 Function	0 = Off 1 = On 2 = N* > Nx 3 = N > Nx 4 = N < Ny 5 = N = N* 6 ... 7 = Not used 8 = F > Fx 9 = Is > lx 10 = Is < lx 11 = Torque > Tx 12 = Torque < Tx 13 = Hours Enabled > Hx 14 ... 15 = Not used 16 = Local Mode 17 = Remote 1 Mode		4428h	9256	enum

Parameter	Description	Range of values	Decimal places	Index	Net Id	Size
		18 = Remote 2 Mode 19 = Run 20 = Ready 21 = STO 22 = No Fault 23 = With Fault 24 = No Alarm 25 = No Fault and Alarm 26 = Network 27 = SoftPLC 28 = Forward Direction 29 = Ride-Through 30 = Pre-Charge OK				
C5.8.4.3	DO3 Function	0 = Off 1 = On 2 = N* > Nx 3 = N > Nx 4 = N < Ny 5 = N = N* 6 ... 7 = Not used 8 = F > Fx 9 = Is > lx 10 = Is < lx 11 = Torque > Tx 12 = Torque < Tx 13 = Hours Enabled > Hx 14 ... 15 = Not used 16 = Local Mode 17 = Remote 1 Mode 18 = Remote 2 Mode 19 = Run 20 = Ready 21 = STO 22 = No Fault 23 = With Fault 24 = No Alarm 25 = No Fault and Alarm 26 = Network 27 = SoftPLC 28 = Forward Direction 29 = Ride-Through 30 = Pre-Charge OK		4429h	9257	enum
C5.8.4.4	DO4 Function	0 = Off 1 = On 2 = N* > Nx 3 = N > Nx 4 = N < Ny 5 = N = N* 6 ... 7 = Not used		442Ah	9258	enum

Parameter	Description	Range of values	Decimal places	Index	Net Id	Size
		8 = F > Fx 9 = Is > lx 10 = Is < lx 11 = Torque > Tx 12 = Torque < Tx 13 = Hours Enabled > Hx 14 ... 15 = Not used 16 = Local Mode 17 = Remote 1 Mode 18 = Remote 2 Mode 19 = Run 20 = Ready 21 = STO 22 = No Fault 23 = With Fault 24 = No Alarm 25 = No Fault and Alarm 26 = Network 27 = SoftPLC 28 = Forward Direction 29 = Ride-Through 30 = Pre-Charge OK				
C5.8.4.5	DO5 Function	0 = Off 1 = On 2 = N* > Nx 3 = N > Nx 4 = N < Ny 5 = N = N* 6 ... 7 = Not used 8 = F > Fx 9 = Is > lx 10 = Is < lx 11 = Torque > Tx 12 = Torque < Tx 13 = Hours Enabled > Hx 14 ... 15 = Not used 16 = Local Mode 17 = Remote 1 Mode 18 = Remote 2 Mode 19 = Run 20 = Ready 21 = STO 22 = No Fault 23 = With Fault 24 = No Alarm 25 = No Fault and Alarm 26 = Network 27 = SoftPLC 28 = Forward Direction 29 = Ride-Through		442Bh	9259	enum

Parameter	Description	Range of values	Decimal places	Index	Net Id	Size
C5.8.4.6	DO6 Function	30 = Pre-Charge OK 0 = Off 1 = On 2 = N* > Nx 3 = N > Nx 4 = N < Ny 5 = N = N* 6 ... 7 = Not used 8 = F > Fx 9 = Is > lx 10 = Is < lx 11 = Torque > Tx 12 = Torque < Tx 13 = Hours Enabled > Hx 14 ... 15 = Not used 16 = Local Mode 17 = Remote 1 Mode 18 = Remote 2 Mode 19 = Run 20 = Ready 21 = STO 22 = No Fault 23 = With Fault 24 = No Alarm 25 = No Fault and Alarm 26 = Network 27 = SoftPLC 28 = Forward Direction 29 = Ride-Through 30 = Pre-Charge OK		442Ch	9260	enum
C5.8.4.7	DO7 Function	0 = Off 1 = On 2 = N* > Nx 3 = N > Nx 4 = N < Ny 5 = N = N* 6 ... 7 = Not used 8 = F > Fx 9 = Is > lx 10 = Is < lx 11 = Torque > Tx 12 = Torque < Tx 13 = Hours Enabled > Hx 14 ... 15 = Not used 16 = Local Mode 17 = Remote 1 Mode 18 = Remote 2 Mode 19 = Run 20 = Ready		442Dh	9261	enum

Parameter	Description	Range of values	Decimal places	Index	Net Id	Size
		21 = STO 22 = No Fault 23 = With Fault 24 = No Alarm 25 = No Fault and Alarm 26 = Network 27 = SoftPLC 28 = Forward Direction 29 = Ride-Through 30 = Pre-Charge OK				
C5.8.4.8	DO8 Function	0 = Off 1 = On 2 = N* > Nx 3 = N > Nx 4 = N < Ny 5 = N = N* 6 ... 7 = Not used 8 = F > Fx 9 = Is > Ix 10 = Is < Ix 11 = Torque > Tx 12 = Torque < Tx 13 = Hours Enabled > Hx 14 ... 15 = Not used 16 = Local Mode 17 = Remote 1 Mode 18 = Remote 2 Mode 19 = Run 20 = Ready 21 = STO 22 = No Fault 23 = With Fault 24 = No Alarm 25 = No Fault and Alarm 26 = Network 27 = SoftPLC 28 = Forward Direction 29 = Ride-Through 30 = Pre-Charge OK		442Eh	9262	enum
C5.8.5	Slot G-Encoder					
C5.8.5.1	Number of Pulses	1 to 65535 ppr	0	4407h	9223	16bit
C5.8.5.2	Settings	Bit 0 = Broken Cable A Bit 2 = Broken Cable B Bit 4 = Broken Cable Z Bit 6 = Search Zero Bit 7 = Signal Direction		4408h	9224	5bit
C5.8.6	Slot G-Temperatures					
C5.8.6.1	Sensor Type			441Eh	9246	enum

Parameter	Description	Range of values	Decimal places	Index	Net Id	Size
		0 = PT100 1 = PT1000 2 = Single PTC 3 = Triple PTC				
C5.8.6.2	Overtemperature Config.	Bit 0 = S1 Sensor F/A Bit 2 = S2 Sensor F/A Bit 4 = S3 Sensor F/A Bit 6 = S4 Sensor F/A Bit 8 = S5 Sensor F/A Bit 10 = S6 Sensor F/A		441Fh	9247	6bit
C5.8.6.3	Broken Cable Config.	Bit 0 = S1 Sensor F/A Bit 2 = S2 Sensor F/A Bit 4 = S3 Sensor F/A Bit 6 = S4 Sensor F/A Bit 8 = S5 Sensor F/A Bit 10 = S6 Sensor F/A		4420h	9248	6bit
C5.8.6.4	Sensor 1 Temp. Setpoint	-100.0 to 250.0 °C	1	4421h	9249	s16bit
C5.8.6.5	Sensor 2 Temp. Setpoint	-100.0 to 250.0 °C	1	4422h	9250	s16bit
C5.8.6.6	Sensor 3 Temp. Setpoint	-100.0 to 250.0 °C	1	4423h	9251	s16bit
C5.8.6.7	Sensor 4 Temp. Setpoint	-100.0 to 250.0 °C	1	4424h	9252	s16bit
C5.8.6.8	Sensor 5 Temp. Setpoint	-100.0 to 250.0 °C	1	4425h	9253	s16bit
C5.8.6.9	Sensor 6 Temp. Setpoint	-100.0 to 250.0 °C	1	4426h	9254	s16bit
C5.9	DO Operation Levels					
C5.9.1	Fx Frequency	0.0 to 300.0 Hz	1	2119h	281	16bit
C5.9.2	Fx Hysteresis	0.0 to 15.0 Hz	1	211Ah	282	16bit
C5.9.3	Nx/Ny Hysteresis	0 to 900 rpm	0	211Fh	287	16bit
C5.9.4	Nx Speed	0 to 30000 rpm	0	2120h	288	16bit
C5.9.5	Ny Speed	0 to 30000 rpm	0	2121h	289	16bit
C5.9.6	Ix Current	0.0 to 200.0 %	1	2122h	290	16bit
C5.9.8	N = N* Band	0 to 30000 rpm	0	2124h	292	16bit
C5.9.9	Tx Torque	0.0 to 200.0 %	1	2125h	293	16bit
C5.9.10	Hx Hours	0 to 65536 h	0	2126h	294	NONE
C5.10	DOs delay					
C5.10.1	Timer 1 DO	0 = Inactive 1 = DO X-1 2 = DO X-2 3 = DO A-1 4 = DO A-2 5 = DO A-3 6 = DO A-4 7 = DO A-5 8 = DO A-6 9 = DO A-7 10 = DO A-8 11 = DO B-1 12 = DO B-2 13 = DO B-3		2134h	308	enum

Parameter	Description	Range of values	Decimal places	Index	Net Id	Size
		14 = DO B-4 15 = DO B-5 16 = DO B-6 17 = DO B-7 18 = DO B-8 19 = DO C-1 20 = DO C-2 21 = DO C-3 22 = DO C-4 23 = DO C-5 24 = DO C-6 25 = DO C-7 26 = DO C-8 27 = DO D-1 28 = DO D-2 29 = DO D-3 30 = DO D-4 31 = DO D-5 32 = DO D-6 33 = DO D-7 34 = DO D-8 35 = DO E-1 36 = DO E-2 37 = DO E-3 38 = DO E-4 39 = DO E-5 40 = DO E-6 41 = DO E-7 42 = DO E-8 43 = DO F-1 44 = DO F-2 45 = DO F-3 46 = DO F-4 47 = DO F-5 48 = DO F-6 49 = DO F-7 50 = DO F-8 51 = DO G-1 52 = DO G-2 53 = DO G-3 54 = DO G-4 55 = DO G-5 56 = DO G-6 57 = DO G-7 58 = DO G-8				
C5.10.2	T1 Delay ON	0.0 to 300.0 s	1	2135h	309	16bit
C5.10.3	T1 Delay OFF	0.0 to 300.0 s	1	2136h	310	16bit
C5.10.4	Timer 2 DO	0 = Inactive 1 = DO X-1 2 = DO X-2		2137h	311	enum



Parameter	Description	Range of values	Decimal places	Index	Net Id	Size
		3 = DO A-1 4 = DO A-2 5 = DO A-3 6 = DO A-4 7 = DO A-5 8 = DO A-6 9 = DO A-7 10 = DO A-8 11 = DO B-1 12 = DO B-2 13 = DO B-3 14 = DO B-4 15 = DO B-5 16 = DO B-6 17 = DO B-7 18 = DO B-8 19 = DO C-1 20 = DO C-2 21 = DO C-3 22 = DO C-4 23 = DO C-5 24 = DO C-6 25 = DO C-7 26 = DO C-8 27 = DO D-1 28 = DO D-2 29 = DO D-3 30 = DO D-4 31 = DO D-5 32 = DO D-6 33 = DO D-7 34 = DO D-8 35 = DO E-1 36 = DO E-2 37 = DO E-3 38 = DO E-4 39 = DO E-5 40 = DO E-6 41 = DO E-7 42 = DO E-8 43 = DO F-1 44 = DO F-2 45 = DO F-3 46 = DO F-4 47 = DO F-5 48 = DO F-6 49 = DO F-7 50 = DO F-8 51 = DO G-1 52 = DO G-2 53 = DO G-3				



Parameter	Description	Range of values	Decimal places	Index	Net Id	Size
		54 = DO G-4 55 = DO G-5 56 = DO G-6 57 = DO G-7 58 = DO G-8				
C5.10.5	T2 Delay ON	0.0 to 300.0 s	1	2138h	312	16bit
C5.10.6	T2 Delay OFF	0.0 to 300.0 s	1	2139h	313	16bit
C5.10.7	Timer 3 DO	0 = Inactive 1 = DO X-1 2 = DO X-2 3 = DO A-1 4 = DO A-2 5 = DO A-3 6 = DO A-4 7 = DO A-5 8 = DO A-6 9 = DO A-7 10 = DO A-8 11 = DO B-1 12 = DO B-2 13 = DO B-3 14 = DO B-4 15 = DO B-5 16 = DO B-6 17 = DO B-7 18 = DO B-8 19 = DO C-1 20 = DO C-2 21 = DO C-3 22 = DO C-4 23 = DO C-5 24 = DO C-6 25 = DO C-7 26 = DO C-8 27 = DO D-1 28 = DO D-2 29 = DO D-3 30 = DO D-4 31 = DO D-5 32 = DO D-6 33 = DO D-7 34 = DO D-8 35 = DO E-1 36 = DO E-2 37 = DO E-3 38 = DO E-4 39 = DO E-5 40 = DO E-6 41 = DO E-7 42 = DO E-8		213Ah	314	enum

Parameter	Description	Range of values	Decimal places	Index	Net Id	Size
		43 = DO F-1 44 = DO F-2 45 = DO F-3 46 = DO F-4 47 = DO F-5 48 = DO F-6 49 = DO F-7 50 = DO F-8 51 = DO G-1 52 = DO G-2 53 = DO G-3 54 = DO G-4 55 = DO G-5 56 = DO G-6 57 = DO G-7 58 = DO G-8				
C5.10.8	T3 Delay ON	0.0 to 300.0 s	1	213Bh	315	16bit
C5.10.9	T3 Delay OFF	0.0 to 300.0 s	1	213Ch	316	16bit
C6 Configurations\Ramps						
C6.1	Speed Control Ramps					
C6.1.1	Acceleration Time	0.1 to 999.9 s	1	2064h	100	16bit
C6.1.2	Deceleration Time	0.1 to 999.9 s	1	2065h	101	16bit
C6.1.3	1st/2nd Ramp Selection	0 = 1st Ramp 1 = 2nd Ramp 2 = Serial 3 = Not used 4 = CAN/CO/DN 5 = SoftPLC 6 = Not used 7 = Ethernet 8 = DI Ramp Selection		2069h	105	enum
C6.1.4	2nd Ramp Acceleration Time	0.1 to 999.9 s	1	2066h	102	16bit
C6.1.5	2nd Ramp Deceleration Time	0.1 to 999.9 s	1	2067h	103	16bit
C6.1.6	Quick Stop Time	0.1 to 999.9 s	1	206Ah	106	16bit
C6.1.7	Ramp Type	0 = Linear 1 = S Ramp		2068h	104	enum
C6.2	Torque Control Ramps					
C6.2.1	Increment Ramp	0.1 to 999.9 s	1	2FA1h	4001	16bit
C6.2.2	Decrement Ramp	0.1 to 999.9 s	1	2FA2h	4002	16bit
C7 Configurations\Protections						
C7.1	Power Supply Phase Loss					
C7.1.1	Min. Detection Time	0 to 60 s	0	2165h	357	16bit
C7.1.2	Level Fine Setting	0.1 to 5.0	1	2166h	358	16bit
C7.2	Ground Fault					
C7.2.1	Configuration	0 = Inactive 1 = Fault Enab.; Standard Level		27D2h	2002	enum

Parameter	Description	Range of values	Decimal places	Index	Net Id	Size
		2 = Fault Enab.; Extended Level				
C7.3	Motor Current Unbal.					
C7.3.1	Enable Fault	0 = Disable 1 = Enable		2156h	342	enum
C7.4	Motor Overload Fault					
C7.4.1	Enable Fault	0 = Disable 1 = Fault and Alarm 2 = Fault 3 = Alarm		215Ch	348	enum
C7.4.2	Alarm Level	10 to 100 %	0	215Dh	349	16bit
C7.4.3	Factor @ 100% Rat. Speed	0 to 200 %	0	209Ch	156	s16bit
C7.4.4	Factor @ 50% Rat. Speed	0 to 200 %	0	209Dh	157	s16bit
C7.4.5	Factor @ 5% Rat, Speed	0 to 200 %	0	209Eh	158	s16bit
C7.4.6	Motor Thermal Class	0 = Class 5E 1 = Class 10E 2 = Class 15 3 = Class 20E 4 = Class 25 5 = Class 30E 6 = Class 35 7 = Class 40 8 = Class 45		209Fh	159	enum
C7.5	Over/Undertemp. Prot.					
C7.5.1	Configuration	Bit 0 = IGBT Overtemp. Bit 1 = Rectifier Overtemp. Bit 2 = Power Circ. Overtemp. Bit 3 = Cont. Circ. Overtemp. Bit 4 = Undertemperature		2161h	353	5bit
C7.5.2	Motor Overtemp. Conf.	0 = Alarm and Fault 1 = Fault 2 = Alarm 3 = Disabled		215Fh	351	enum
C7.6	Fan Speed Fault					
C7.6.1	Power Fan Setting	0 = Alarm/Fault 1 = Alarm		2162h	354	enum
C7.6.2	Internal Fan Setting	0 = Alarm/Fault 1 = Alarm		241Eh	1054	enum
C7.7	Motor Overspeed					
C7.7.1	Maximum Overspeed Level	0 to 100 %	0	2084h	132	TIME
C7.8	Pre-charge					
C7.8.1	Pre-charge Fault Config.			27D8h	2008	4bit

Parameter	Description	Range of values	Decimal places	Index	Net Id	Size
		Bit 0 = Phase disconnected Bit 1 = Freq. out of range Bit 2 = Input Voltage Unbalance Bit 3 = Input Phase Unbalance				
C7.9	Auto-Reset					
C7.9.1	Time	0 to 3600 s	0	2154h	340	16bit
C7.10	External Fault/Alarm					
C7.10.1	External Alarm DI	0 = Inactive 1 = DI X-1 2 = DI X-2 3 = DI X-3 4 = DI X-4 5 = DI X-5 6 = DI X-6 7 = DI A-1 8 = DI A-2 9 = DI A-3 10 = DI A-4 11 = DI A-5 12 = DI A-6 13 = DI A-7 14 = DI A-8 15 = DI B-1 16 = DI B-2 17 = DI B-3 18 = DI B-4 19 = DI B-5 20 = DI B-6 21 = DI B-7 22 = DI B-8 23 = DI C-1 24 = DI C-2 25 = DI C-3 26 = DI C-4 27 = DI C-5 28 = DI C-6 29 = DI C-7 30 = DI C-8 31 = DI D-1 32 = DI D-2 33 = DI D-3 34 = DI D-4 35 = DI D-5 36 = DI D-6 37 = DI D-7 38 = DI D-8 39 = DI E-1 40 = DI E-2 41 = DI E-3		3796h	6038	enum



Parameter	Description	Range of values	Decimal places	Index	Net Id	Size
		42 = DI E-4 43 = DI E-5 44 = DI E-6 45 = DI E-7 46 = DI E-8 47 = DI F-1 48 = DI F-2 49 = DI F-3 50 = DI F-4 51 = DI F-5 52 = DI F-6 53 = DI F-7 54 = DI F-8 55 = DI G-1 56 = DI G-2 57 = DI G-3 58 = DI G-4 59 = DI G-5 60 = DI G-6 61 = DI G-7 62 = DI G-8				
C7.10.2	External Fault DI	0 = Inactive 1 = DI X-1 2 = DI X-2 3 = DI X-3 4 = DI X-4 5 = DI X-5 6 = DI X-6 7 = DI A-1 8 = DI A-2 9 = DI A-3 10 = DI A-4 11 = DI A-5 12 = DI A-6 13 = DI A-7 14 = DI A-8 15 = DI B-1 16 = DI B-2 17 = DI B-3 18 = DI B-4 19 = DI B-5 20 = DI B-6 21 = DI B-7 22 = DI B-8 23 = DI C-1 24 = DI C-2 25 = DI C-3 26 = DI C-4 27 = DI C-5 28 = DI C-6		3795h	6037	enum

Parameter	Description	Range of values	Decimal places	Index	Net Id	Size
		29 = DI C-7 30 = DI C-8 31 = DI D-1 32 = DI D-2 33 = DI D-3 34 = DI D-4 35 = DI D-5 36 = DI D-6 37 = DI D-7 38 = DI D-8 39 = DI E-1 40 = DI E-2 41 = DI E-3 42 = DI E-4 43 = DI E-5 44 = DI E-6 45 = DI E-7 46 = DI E-8 47 = DI F-1 48 = DI F-2 49 = DI F-3 50 = DI F-4 51 = DI F-5 52 = DI F-6 53 = DI F-7 54 = DI F-8 55 = DI G-1 56 = DI G-2 57 = DI G-3 58 = DI G-4 59 = DI G-5 60 = DI G-6 61 = DI G-7 62 = DI G-8				
C7.11	Thermal Management					
C7.11.2	Temperature Regulator Config.	Bit 0 = Heat sink Temp. Reg. with fsw Operation Bit 1 = Junction Temperature Regulator Bit 2 = Heat sink Temp. Reg. w/ Power Fan Speed		2BDDh	3037	3bit
C7.12	Encoder					
C7.12.1	Encoder Protection Config.	0 = F67 inactive 1 = F67 active		2163h	355	enum
C7.13	History					
C7.13.1	Enable Alarm Hist.	0 = Disabled 1 = Enabled		305Eh	4190	enum

Parameter	Description	Range of values	Decimal places	Index	Net Id	Size
C8 Configurations\Functional Safety						
C8.1	SS1-t Ramp Deceleration Time	0.1 to 999.9 s	1	2060h	96	16bit
C9 Configurations\Communications						
C9.1	Communication Errors					
C9.1.1	Master Offline					
C9.1.1.1	Mode	0 = Inactive 1 = Fault 2 = Alarm		237Fh	895	enum
C9.1.1.2	Alarm Action	0 = Off 1 = Stop by Ramp 2 = General Disable 3 = Go to R1 4 = Go to R2		2380h	896	enum
C9.1.2	Master Idle/Prog					
C9.1.2.1	Mode	0 = Inactive 1 = Fault 2 = Alarm		2381h	897	enum
C9.1.2.2	Alarm Action	0 = Off 1 = Stop by Ramp 2 = General Disable 3 = Go to R1 4 = Go to R2		2382h	898	enum
C9.2	I/O Data					
C9.2.1	Reading Data					
C9.2.1.1	Word #1	0 to 9999	0	2514h	1300	s16bit
C9.2.1.2	Word #2	0 to 9999	0	2515h	1301	s16bit
C9.2.1.3	Word #3	0 to 9999	0	2516h	1302	s16bit
C9.2.1.4	Word #4	0 to 9999	0	2517h	1303	s16bit
C9.2.1.5	Word #5	0 to 9999	0	2518h	1304	s16bit
C9.2.1.6	Word #6	0 to 9999	0	2519h	1305	s16bit
C9.2.1.7	Word #7	0 to 9999	0	251Ah	1306	s16bit
C9.2.1.8	Word #8	0 to 9999	0	251Bh	1307	s16bit
C9.2.1.9	Word #9	0 to 9999	0	251Ch	1308	s16bit
C9.2.1.10	Word #10	0 to 9999	0	251Dh	1309	s16bit
C9.2.1.11	Word #11	0 to 9999	0	251Eh	1310	s16bit
C9.2.1.12	Word #12	0 to 9999	0	251Fh	1311	s16bit
C9.2.1.13	Word #13	0 to 9999	0	2520h	1312	s16bit
C9.2.1.14	Word #14	0 to 9999	0	2521h	1313	s16bit
C9.2.1.15	Word #15	0 to 9999	0	2522h	1314	s16bit
C9.2.1.16	Word #16	0 to 9999	0	2523h	1315	s16bit
C9.2.1.17	Word #17	0 to 9999	0	2524h	1316	s16bit
C9.2.1.18	Word #18	0 to 9999	0	2525h	1317	s16bit
C9.2.1.19	Word #19	0 to 9999	0	2526h	1318	s16bit
C9.2.1.20	Word #20	0 to 9999	0	2527h	1319	s16bit
C9.2.1.21	Word #21	0 to 9999	0	2528h	1320	s16bit



Parameter	Description	Range of values	Decimal places	Index	Net Id	Size
C9.2.1.22	Word #22	0 to 9999	0	2529h	1321	s16bit
C9.2.1.23	Word #23	0 to 9999	0	252Ah	1322	s16bit
C9.2.1.24	Word #24	0 to 9999	0	252Bh	1323	s16bit
C9.2.1.25	Word #25	0 to 9999	0	252Ch	1324	s16bit
C9.2.1.26	Word #26	0 to 9999	0	252Dh	1325	s16bit
C9.2.1.27	Word #27	0 to 9999	0	252Eh	1326	s16bit
C9.2.1.28	Word #28	0 to 9999	0	252Fh	1327	s16bit
C9.2.1.29	Word #29	0 to 9999	0	2530h	1328	s16bit
C9.2.1.30	Word #30	0 to 9999	0	2531h	1329	s16bit
C9.2.1.31	Word #31	0 to 9999	0	2532h	1330	s16bit
C9.2.1.32	Word #32	0 to 9999	0	2533h	1331	s16bit
C9.2.1.33	Word #33	0 to 9999	0	2534h	1332	s16bit
C9.2.1.34	Word #34	0 to 9999	0	2535h	1333	s16bit
C9.2.1.35	Word #35	0 to 9999	0	2536h	1334	s16bit
C9.2.1.36	Word #36	0 to 9999	0	2537h	1335	s16bit
C9.2.1.37	Word #37	0 to 9999	0	2538h	1336	s16bit
C9.2.1.38	Word #38	0 to 9999	0	2539h	1337	s16bit
C9.2.1.39	Word #39	0 to 9999	0	253Ah	1338	s16bit
C9.2.1.40	Word #40	0 to 9999	0	253Bh	1339	s16bit
C9.2.1.41	Word #41	0 to 9999	0	253Ch	1340	s16bit
C9.2.1.42	Word #42	0 to 9999	0	253Dh	1341	s16bit
C9.2.1.43	Word #43	0 to 9999	0	253Eh	1342	s16bit
C9.2.1.44	Word #44	0 to 9999	0	253Fh	1343	s16bit
C9.2.1.45	Word #45	0 to 9999	0	2540h	1344	s16bit
C9.2.1.46	Word #46	0 to 9999	0	2541h	1345	s16bit
C9.2.1.47	Word #47	0 to 9999	0	2542h	1346	s16bit
C9.2.1.48	Word #48	0 to 9999	0	2543h	1347	s16bit
C9.2.1.49	Word #49	0 to 9999	0	2544h	1348	s16bit
C9.2.1.50	Word #50	0 to 9999	0	2545h	1349	s16bit
C9.2.1.51	Word #51	0 to 9999	0	2546h	1350	s16bit
C9.2.1.52	Word #52	0 to 9999	0	2547h	1351	s16bit
C9.2.1.53	Word #53	0 to 9999	0	2548h	1352	s16bit
C9.2.1.54	Word #54	0 to 9999	0	2549h	1353	s16bit
C9.2.1.55	Word #55	0 to 9999	0	254Ah	1354	s16bit
C9.2.1.56	Word #56	0 to 9999	0	254Bh	1355	s16bit
C9.2.1.57	Word #57	0 to 9999	0	254Ch	1356	s16bit
C9.2.1.58	Word #58	0 to 9999	0	254Dh	1357	s16bit
C9.2.1.59	Word #59	0 to 9999	0	254Eh	1358	s16bit
C9.2.1.60	Word #60	0 to 9999	0	254Fh	1359	s16bit
C9.2.1.61	Word #61	0 to 9999	0	2550h	1360	s16bit
C9.2.1.62	Word #62	0 to 9999	0	2551h	1361	s16bit
C9.2.1.63	Word #63	0 to 9999	0	2552h	1362	s16bit
C9.2.1.64	Word #64	0 to 9999	0	2553h	1363	s16bit
C9.2.1.65	Word #65	0 to 9999	0	2554h	1364	s16bit
C9.2.1.66	Word #66	0 to 9999	0	2555h	1365	s16bit
C9.2.1.67	Word #67	0 to 9999	0	2556h	1366	s16bit
C9.2.1.68	Word #68	0 to 9999	0	2557h	1367	s16bit
C9.2.1.69	Word #69	0 to 9999	0	2558h	1368	s16bit
C9.2.1.70	Word #70	0 to 9999	0	2559h	1369	s16bit
C9.2.1.71	Word #71	0 to 9999	0	255Ah	1370	s16bit
C9.2.1.72	Word #72	0 to 9999	0	255Bh	1371	s16bit

Parameter	Description	Range of values	Decimal places	Index	Net Id	Size
C9.2.1.73	Word #73	0 to 9999	0	255Ch	1372	s16bit
C9.2.1.74	Word #74	0 to 9999	0	255Dh	1373	s16bit
C9.2.1.75	Word #75	0 to 9999	0	255Eh	1374	s16bit
C9.2.1.76	Word #76	0 to 9999	0	255Fh	1375	s16bit
C9.2.1.77	Word #77	0 to 9999	0	2560h	1376	s16bit
C9.2.1.78	Word #78	0 to 9999	0	2561h	1377	s16bit
C9.2.1.79	Word #79	0 to 9999	0	2562h	1378	s16bit
C9.2.1.80	Word #80	0 to 9999	0	2563h	1379	s16bit
C9.2.1.81	Word #81	0 to 9999	0	2564h	1380	s16bit
C9.2.1.82	Word #82	0 to 9999	0	2565h	1381	s16bit
C9.2.1.83	Word #83	0 to 9999	0	2566h	1382	s16bit
C9.2.1.84	Word #84	0 to 9999	0	2567h	1383	s16bit
C9.2.1.85	Word #85	0 to 9999	0	2568h	1384	s16bit
C9.2.1.86	Word #86	0 to 9999	0	2569h	1385	s16bit
C9.2.1.87	Word #87	0 to 9999	0	256Ah	1386	s16bit
C9.2.1.88	Word #88	0 to 9999	0	256Bh	1387	s16bit
C9.2.1.89	Word #89	0 to 9999	0	256Ch	1388	s16bit
C9.2.1.90	Word #90	0 to 9999	0	256Dh	1389	s16bit
C9.2.1.91	Word #91	0 to 9999	0	256Eh	1390	s16bit
C9.2.1.92	Word #92	0 to 9999	0	256Fh	1391	s16bit
C9.2.1.93	Word #93	0 to 9999	0	2570h	1392	s16bit
C9.2.1.94	Word #94	0 to 9999	0	2571h	1393	s16bit
C9.2.1.95	Word #95	0 to 9999	0	2572h	1394	s16bit
C9.2.1.96	Word #96	0 to 9999	0	2573h	1395	s16bit
C9.2.1.97	Word #97	0 to 9999	0	2574h	1396	s16bit
C9.2.1.98	Word #98	0 to 9999	0	2575h	1397	s16bit
C9.2.1.99	Word #99	0 to 9999	0	2576h	1398	s16bit
C9.2.1.100	Word #100	0 to 9999	0	2577h	1399	s16bit
C9.2.2	Writing Data					
C9.2.2.1	Update Delay	0.0 to 999.0 s	1	2383h	899	16bit
C9.2.2.2	Word #1	0 to 9999	0	2578h	1400	s16bit
C9.2.2.3	Word #2	0 to 9999	0	2579h	1401	s16bit
C9.2.2.4	Word #3	0 to 9999	0	257Ah	1402	s16bit
C9.2.2.5	Word #4	0 to 9999	0	257Bh	1403	s16bit
C9.2.2.6	Word #5	0 to 9999	0	257Ch	1404	s16bit
C9.2.2.7	Word #6	0 to 9999	0	257Dh	1405	s16bit
C9.2.2.8	Word #7	0 to 9999	0	257Eh	1406	s16bit
C9.2.2.9	Word #8	0 to 9999	0	257Fh	1407	s16bit
C9.2.2.10	Word #9	0 to 9999	0	2580h	1408	s16bit
C9.2.2.11	Word #10	0 to 9999	0	2581h	1409	s16bit
C9.2.2.12	Word #11	0 to 9999	0	2582h	1410	s16bit
C9.2.2.13	Word #12	0 to 9999	0	2583h	1411	s16bit
C9.2.2.14	Word #13	0 to 9999	0	2584h	1412	s16bit
C9.2.2.15	Word #14	0 to 9999	0	2585h	1413	s16bit
C9.2.2.16	Word #15	0 to 9999	0	2586h	1414	s16bit
C9.2.2.17	Word #16	0 to 9999	0	2587h	1415	s16bit
C9.2.2.18	Word #17	0 to 9999	0	2588h	1416	s16bit
C9.2.2.19	Word #18	0 to 9999	0	2589h	1417	s16bit
C9.2.2.20	Word #19	0 to 9999	0	258Ah	1418	s16bit
C9.2.2.21	Word #20	0 to 9999	0	258Bh	1419	s16bit
C9.2.2.22	Word #21	0 to 9999	0	258Ch	1420	s16bit



Parameter	Description	Range of values	Decimal places	Index	Net Id	Size
C9.2.2.23	Word #22	0 to 9999	0	258Dh	1421	s16bit
C9.2.2.24	Word #23	0 to 9999	0	258Eh	1422	s16bit
C9.2.2.25	Word #24	0 to 9999	0	258Fh	1423	s16bit
C9.2.2.26	Word #25	0 to 9999	0	2590h	1424	s16bit
C9.2.2.27	Word #26	0 to 9999	0	2591h	1425	s16bit
C9.2.2.28	Word #27	0 to 9999	0	2592h	1426	s16bit
C9.2.2.29	Word #28	0 to 9999	0	2593h	1427	s16bit
C9.2.2.30	Word #29	0 to 9999	0	2594h	1428	s16bit
C9.2.2.31	Word #30	0 to 9999	0	2595h	1429	s16bit
C9.2.2.32	Word #31	0 to 9999	0	2596h	1430	s16bit
C9.2.2.33	Word #32	0 to 9999	0	2597h	1431	s16bit
C9.2.2.34	Word #33	0 to 9999	0	2598h	1432	s16bit
C9.2.2.35	Word #34	0 to 9999	0	2599h	1433	s16bit
C9.2.2.36	Word #35	0 to 9999	0	259Ah	1434	s16bit
C9.2.2.37	Word #36	0 to 9999	0	259Bh	1435	s16bit
C9.2.2.38	Word #37	0 to 9999	0	259Ch	1436	s16bit
C9.2.2.39	Word #38	0 to 9999	0	259Dh	1437	s16bit
C9.2.2.40	Word #39	0 to 9999	0	259Eh	1438	s16bit
C9.2.2.41	Word #40	0 to 9999	0	259Fh	1439	s16bit
C9.2.2.42	Word #41	0 to 9999	0	25A0h	1440	s16bit
C9.2.2.43	Word #42	0 to 9999	0	25A1h	1441	s16bit
C9.2.2.44	Word #43	0 to 9999	0	25A2h	1442	s16bit
C9.2.2.45	Word #44	0 to 9999	0	25A3h	1443	s16bit
C9.2.2.46	Word #45	0 to 9999	0	25A4h	1444	s16bit
C9.2.2.47	Word #46	0 to 9999	0	25A5h	1445	s16bit
C9.2.2.48	Word #47	0 to 9999	0	25A6h	1446	s16bit
C9.2.2.49	Word #48	0 to 9999	0	25A7h	1447	s16bit
C9.2.2.50	Word #49	0 to 9999	0	25A8h	1448	s16bit
C9.2.2.51	Word #50	0 to 9999	0	25A9h	1449	s16bit
C9.2.2.52	Word #51	0 to 9999	0	25AAh	1450	s16bit
C9.2.2.53	Word #52	0 to 9999	0	25ABh	1451	s16bit
C9.2.2.54	Word #53	0 to 9999	0	25ACh	1452	s16bit
C9.2.2.55	Word #54	0 to 9999	0	25ADh	1453	s16bit
C9.2.2.56	Word #55	0 to 9999	0	25AEh	1454	s16bit
C9.2.2.57	Word #56	0 to 9999	0	25AFh	1455	s16bit
C9.2.2.58	Word #57	0 to 9999	0	25B0h	1456	s16bit
C9.2.2.59	Word #58	0 to 9999	0	25B1h	1457	s16bit
C9.2.2.60	Word #59	0 to 9999	0	25B2h	1458	s16bit
C9.2.2.61	Word #60	0 to 9999	0	25B3h	1459	s16bit
C9.2.2.62	Word #61	0 to 9999	0	25B4h	1460	s16bit
C9.2.2.63	Word #62	0 to 9999	0	25B5h	1461	s16bit
C9.2.2.64	Word #63	0 to 9999	0	25B6h	1462	s16bit
C9.2.2.65	Word #64	0 to 9999	0	25B7h	1463	s16bit
C9.2.2.66	Word #65	0 to 9999	0	25B8h	1464	s16bit
C9.2.2.67	Word #66	0 to 9999	0	25B9h	1465	s16bit
C9.2.2.68	Word #67	0 to 9999	0	25BAh	1466	s16bit
C9.2.2.69	Word #68	0 to 9999	0	25BBh	1467	s16bit
C9.2.2.70	Word #69	0 to 9999	0	25BCh	1468	s16bit
C9.2.2.71	Word #70	0 to 9999	0	25BDh	1469	s16bit
C9.2.2.72	Word #71	0 to 9999	0	25BEh	1470	s16bit
C9.2.2.73	Word #72	0 to 9999	0	25BFh	1471	s16bit

Parameter	Description	Range of values	Decimal places	Index	Net Id	Size
C9.2.2.74	Word #73	0 to 9999	0	25C0h	1472	s16bit
C9.2.2.75	Word #74	0 to 9999	0	25C1h	1473	s16bit
C9.2.2.76	Word #75	0 to 9999	0	25C2h	1474	s16bit
C9.2.2.77	Word #76	0 to 9999	0	25C3h	1475	s16bit
C9.2.2.78	Word #77	0 to 9999	0	25C4h	1476	s16bit
C9.2.2.79	Word #78	0 to 9999	0	25C5h	1477	s16bit
C9.2.2.80	Word #79	0 to 9999	0	25C6h	1478	s16bit
C9.2.2.81	Word #80	0 to 9999	0	25C7h	1479	s16bit
C9.2.2.82	Word #81	0 to 9999	0	25C8h	1480	s16bit
C9.2.2.83	Word #82	0 to 9999	0	25C9h	1481	s16bit
C9.2.2.84	Word #83	0 to 9999	0	25CAh	1482	s16bit
C9.2.2.85	Word #84	0 to 9999	0	25CBh	1483	s16bit
C9.2.2.86	Word #85	0 to 9999	0	25CCh	1484	s16bit
C9.2.2.87	Word #86	0 to 9999	0	25CDh	1485	s16bit
C9.2.2.88	Word #87	0 to 9999	0	25CEh	1486	s16bit
C9.2.2.89	Word #88	0 to 9999	0	25CFh	1487	s16bit
C9.2.2.90	Word #89	0 to 9999	0	25D0h	1488	s16bit
C9.2.2.91	Word #90	0 to 9999	0	25D1h	1489	s16bit
C9.2.2.92	Word #91	0 to 9999	0	25D2h	1490	s16bit
C9.2.2.93	Word #92	0 to 9999	0	25D3h	1491	s16bit
C9.2.2.94	Word #93	0 to 9999	0	25D4h	1492	s16bit
C9.2.2.95	Word #94	0 to 9999	0	25D5h	1493	s16bit
C9.2.2.96	Word #95	0 to 9999	0	25D6h	1494	s16bit
C9.2.2.97	Word #96	0 to 9999	0	25D7h	1495	s16bit
C9.2.2.98	Word #97	0 to 9999	0	25D8h	1496	s16bit
C9.2.2.99	Word #98	0 to 9999	0	25D9h	1497	s16bit
C9.2.2.100	Word #99	0 to 9999	0	25DAh	1498	s16bit
C9.2.2.101	Word #100	0 to 9999	0	25DBh	1499	s16bit
C9.3	Serial RS485					
C9.3.1	Protocol	0 ... 1 = Not used 2 = Modbus RTU		22DAh	730	enum
C9.3.2	Address	1 to 247	0	22DBh	731	8bit
C9.3.3	Baud Rate	0 = 9600 bit/s 1 = 19200 bit/s 2 = 38400 bit/s 3 = 57600 bit/s		22DCh	732	enum
C9.3.4	Bytes Configuration	0 = 8-bits, no, 1 1 = 8-bits, even, 1 2 = 8-bits, odd, 1 3 = 8-bits, no, 2 4 = 8-bits, even, 2 5 = 8-bits, odd, 2		22DDh	733	enum
C9.3.5	RS485 Timeout	0.0 to 999.0 s	1	22DEh	734	16bit
C9.4	Ethernet					
C9.4.1	IP Address Settings	0 = Parameters 1 = DHCP		2352h	850	enum



Parameter	Description	Range of values	Decimal places	Index	Net Id	Size
C9.4.2	IP Address	0.0.0.0 to 255.255.255.255		2354h	852	STRING
C9.4.3	Network Mask	0 = Not used 1 = 128.0.0.0 2 = 192.0.0.0 3 = 224.0.0.0 4 = 240.0.0.0 5 = 248.0.0.0 6 = 252.0.0.0 7 = 254.0.0.0 8 = 255.0.0.0 9 = 255.128.0.0 10 = 255.192.0.0 11 = 255.224.0.0 12 = 255.240.0.0 13 = 255.248.0.0 14 = 255.252.0.0 15 = 255.254.0.0 16 = 255.255.0.0 17 = 255.255.128.0 18 = 255.255.192.0 19 = 255.255.224.0 20 = 255.255.240.0 21 = 255.255.248.0 22 = 255.255.252.0 23 = 255.255.254.0 24 = 255.255.255.0 25 = 255.255.255.128 26 = 255.255.255.192 27 = 255.255.255.224 28 = 255.255.255.240 29 = 255.255.255.248 30 = 255.255.255.252 31 = 255.255.255.254		2357h	855	enum
C9.4.4	Gateway	0.0.0.0 to 255.255.255.255		2358h	856	STRING
C9.4.5	SNTP - Server 1	0.0.0.0 to 255.255.255.255		2302h	770	STRING
C9.4.6	SNTP - Server 2	0.0.0.0 to 255.255.255.255		2306h	774	STRING
C9.4.7	SNTP - Update	0 to 65535	0	230Bh	779	16bit
C9.4.8	Enable protocols	Bit 0 = Web Server Bit 1 ... 2 = Not used		231Eh	798	3bit
C9.5	EtherNet/IP					
C9.5.1	EtherNet/IP I/O Instances	0 = 20/70 CIP 1 = 21/71 CIP 2 ... 3 = Not used 4 = 120/170 CIP + I/O data 5 = 121/171 CIP + I/O data 6 ... 7 = Not used 8 = 100/150 Manuf. + I/O data		2367h	871	enum



Parameter	Description	Range of values	Decimal places	Index	Net Id	Size
		9 = 101/151 Manuf. + I/O data 10 = 102/152 Config I/O data				
C9.5.2	Readings 1st Word	1 to 100	0	2368h	872	s16bit
C9.5.3	Readings Quantity	0 to 50	0	2369h	873	s16bit
C9.5.4	Writings 1st Word	1 to 100	0	236Ah	874	s16bit
C9.5.5	Writings Quantity	0 to 50	0	236Bh	875	s16bit
C9.6	Modbus TCP					
C9.6.1	TCP Port	0 to 65535	0	2361h	865	16bit
C9.6.3	Timeout	0.0 to 999.0 s	1	2364h	868	16bit
C9.7	Anybus					
C9.7.1	Readings 1st Word	1 to 100	0	22F1h	753	8bit
C9.7.2	Readings Quantity	2 to 50	0	22F2h	754	8bit
C9.7.3	Writings 1st Word	1 to 100	0	22F3h	755	8bit
C9.7.4	Writings Quantity	2 to 50	0	22F4h	756	8bit
C9.7.5	Address	0 to 255	0	22F5h	757	16bit
C9.7.8	IP Address Settings			22F8h	760	enum
		0 = Parameters 1 = DHCP				
C9.7.9	IP Address	0.0.0.0 to 255.255.255.255		22FAh	762	STRING
C9.7.10	CIDR Subnet			22F9h	761	enum
		0 = Not used 1 = 128.0.0.0 2 = 192.0.0.0 3 = 224.0.0.0 4 = 240.0.0.0 5 = 248.0.0.0 6 = 252.0.0.0 7 = 254.0.0.0 8 = 255.0.0.0 9 = 255.128.0.0 10 = 255.192.0.0 11 = 255.224.0.0 12 = 255.240.0.0 13 = 255.248.0.0 14 = 255.252.0.0 15 = 255.254.0.0 16 = 255.255.0.0 17 = 255.255.128.0 18 = 255.255.192.0 19 = 255.255.224.0 20 = 255.255.240.0 21 = 255.255.248.0 22 = 255.255.252.0 23 = 255.255.254.0 24 = 255.255.255.0 25 = 255.255.255.128 26 = 255.255.255.192 27 = 255.255.255.224 28 = 255.255.255.240 29 = 255.255.255.248				

Parameter	Description	Range of values	Decimal places	Index	Net Id	Size
C9.7.11	Gateway	30 = 255.255.255.252 31 = 255.255.255.254 0.0.0.0 to 255.255.255.255		22FEh	766	STRING
C9.8	CAN/CANopen/DNet					
C9.8.1	Protocol	0 = Disabled 1 = CANopen 2 = DeviceNet		22BCh	700	enum
C9.8.2	Address	0 to 127	0	22BDh	701	16bit
C9.8.3	Baud Rate	0 = 1 Mbps/Auto 1 = Not used/Auto 2 = 500 Kbps 3 = 250 Kbps 4 = 125 Kbps 5 = 100 Kbps/Auto		22BEh	702	enum
C9.8.4	Bus Off Reset	0 = Manual 1 = Automatic		22BFh	703	enum
C9.8.5	DeviceNet I/O Instances	0 = 20/70 CIP 1 = 21/71 CIP 2 ... 3 = Not used 4 = 120/170 CIP + I/O data 5 = 121/171 CIP + I/O data 6 ... 7 = Not used 8 = 100/150 Manuf. + I/O data 9 = 101/151 Manuf. + I/O data 10 = 102/152 Config I/O data		22C6h	710	enum
C9.8.6	DNet Reading 1st Word	1 to 100	0	22C8h	712	s16bit
C9.8.7	DNet Reading Quantity	0 to 50	0	22C9h	713	s16bit
C9.8.8	DNet Writing 1st Word	1 to 100	0	22CAh	714	s16bit
C9.8.9	DNet Writing Quantity	0 to 50	0	22CBh	715	s16bit
C9.9	Bluetooth					
C9.9.1	Mode	0 = Inactive 1 = Active		2320h	800	enum
C9.9.2	PIN	6 to 6	0	2324h	804	NONE
C9.9.3	Device Name	1 to 15	0	2328h	808	NONE
C9.10	SymbiNet					
C9.10.1	Enable Protocol	0 = Disable 1 = Enable		2424h	1060	enum
C9.10.2	Publication Time	2 to 100 ms	0	2425h	1061	16bit
C9.10.3	Grp1: Source Addr.	0 to 254	0	242Ch	1068	16bit
C9.10.4	Grp1: Source Reg.	0 to 65535	0	242Dh	1069	16bit
C9.10.5	Grp1: Dest. Reg.	0 to 65535	0	242Eh	1070	16bit
C9.10.6	Grp1: Num. of Registers	0 to 8	0	242Fh	1071	16bit
C9.10.7	Grp2: Source Addr.	0 to 254	0	2430h	1072	16bit

Parameter	Description	Range of values	Decimal places	Index	Net Id	Size
C9.10.8	Grp2: Source Reg.	0 to 65535	0	2431h	1073	16bit
C9.10.9	Grp2: Dest. Reg.	0 to 65535	0	2432h	1074	16bit
C9.10.10	Grp2: Num. of Registers	0 to 8	0	2433h	1075	16bit
C9.10.11	Grp3: Source Addr.	0 to 254	0	2434h	1076	16bit
C9.10.12	Grp3: Source Reg.	0 to 65535	0	2435h	1077	16bit
C9.10.13	Grp3: Dest. Reg.	0 to 65535	0	2436h	1078	16bit
C9.10.14	Grp3: Num. of Registers	0 to 8	0	2437h	1079	16bit
C9.10.15	Grp4: Source Addr.	0 to 254	0	2438h	1080	16bit
C9.10.16	Grp4: Source Reg.	0 to 65535	0	2439h	1081	16bit
C9.10.17	Grp4: Dest. Reg.	0 to 65535	0	243Ah	1082	16bit
C9.10.18	Grp4: Num. of Registers	0 to 8	0	243Bh	1083	16bit
C9.10.19	Grp5: Source Addr.	0 to 254	0	243Ch	1084	16bit
C9.10.20	Grp5: Source Reg.	0 to 65535	0	243Dh	1085	16bit
C9.10.21	Grp5: Dest. Reg.	0 to 65535	0	243Eh	1086	16bit
C9.10.22	Grp5: Num. of Registers	0 to 8	0	243Fh	1087	16bit
C9.10.23	Grp6: Source Addr.	0 to 254	0	2440h	1088	16bit
C9.10.24	Grp6: Source Reg.	0 to 65535	0	2441h	1089	16bit
C9.10.25	Grp6: Dest. Reg.	0 to 65535	0	2442h	1090	16bit
C9.10.26	Grp6: Num. of Registers	0 to 8	0	2443h	1091	16bit
C9.10.27	Grp7: Source Addr.	0 to 254	0	2444h	1092	16bit
C9.10.28	Grp7: Source Reg.	0 to 65535	0	2445h	1093	16bit
C9.10.29	Grp7: Dest. Reg.	0 to 65535	0	2446h	1094	16bit
C9.10.30	Grp7: Num. of Registers	0 to 8	0	2447h	1095	16bit
C9.10.31	Grp8: Source Addr.	0 to 254	0	2448h	1096	16bit
C9.10.32	Grp8: Source Reg.	0 to 65535	0	2449h	1097	16bit
C9.10.33	Grp8: Dest. Reg.	0 to 65535	0	244Ah	1098	16bit
C9.10.34	Grp8: Num. of Registers	0 to 8	0	244Bh	1099	16bit
C10 Configurations\SoftPLC						
C10.1	Configuration					
C10.1.1	Command	0 = Stop 1 = Run 2 ... 4 = Not used 5 = Erase		33ECh	5100	enum
C10.1.2	Active Application	0 = User Application 1 1 = User Application 2 2 ... 6 = Not used		33EDh	5101	enum
C10.1.3	Application Stopped Action	0 = Inactive 1 = Generate Alarm 2 = Trip Fault		33EEh	5102	enum
C10.2	Engineering Unit					
C10.2.1	Engineering Unit 1	0 = No Unit 1 = A 2 = bar 3 = °C 4 = CPM 5 = CV		3400h	5120	enum



Parameter	Description	Range of values	Decimal places	Index	Net Id	Size
		6 = ft ³ 7 = ft ³ /h 8 = ft ³ /min 9 = ft ³ /s 10 = m ³ 11 = m ³ /h 12 = m ³ /min 13 = m ³ /s 14 = °F 15 = ft 16 = ft/h 17 = ft/min 18 = ft/s 19 = gal 20 = gal/h 21 = gal/min 22 = gal/s 23 = H 24 = Hz 25 = HP 26 = h 27 = in 28 = lnWC 29 = K 30 = kg 31 = kgf 32 = kgf/cm ² 33 = kgf/m ² 34 = kl/h 35 = kPa 36 = kW 37 = kWh 38 = l 39 = l/h 40 = l/min 41 = l/s 42 = lbf 43 = mA 44 = mca 45 = m 46 = m/h 47 = m/min 48 = m/s 49 = mbar 50 = ms 51 = min 52 = MPa 53 = mwc 54 = N 55 = Nm 56 = Pa				



Parameter	Description	Range of values	Decimal places	Index	Net Id	Size
		57 = % 58 = psi 59 = rpm 60 = s 61 = V 62 = W 63 = W/m ² 64 = Wh/m ²				
C10.2.2	Dec. Point Eng. Unit 1	0 to 3	0	3401h	5121	8bit
C10.2.3	Engineering Unit 2	0 = No Unit 1 = A 2 = bar 3 = °C 4 = CPM 5 = CV 6 = ft ³ 7 = ft ³ /h 8 = ft ³ /min 9 = ft ³ /s 10 = m ³ 11 = m ³ /h 12 = m ³ /min 13 = m ³ /s 14 = °F 15 = ft 16 = ft/h 17 = ft/min 18 = ft/s 19 = gal 20 = gal/h 21 = gal/min 22 = gal/s 23 = H 24 = Hz 25 = HP 26 = h 27 = in 28 = lnWC 29 = K 30 = kg 31 = kgf 32 = kgf/cm ² 33 = kgf/m ² 34 = kl/h 35 = kPa 36 = kW 37 = kWh 38 = l 39 = l/h 40 = l/min		3402h	5122	enum



Parameter	Description	Range of values	Decimal places	Index	Net Id	Size
		41 = l/s 42 = lbf 43 = mA 44 = mca 45 = m 46 = m/h 47 = m/min 48 = m/s 49 = mbar 50 = ms 51 = min 52 = MPa 53 = mwc 54 = N 55 = Nm 56 = Pa 57 = % 58 = psi 59 = rpm 60 = s 61 = V 62 = W 63 = W/m ² 64 = Wh/m ²				
C10.2.4	Dec. Point Eng. Unit 2	0 to 3	0	3403h	5123	8bit
C10.2.5	Engineering Unit 3	0 = No Unit 1 = A 2 = bar 3 = °C 4 = CPM 5 = CV 6 = ft ³ 7 = ft ³ /h 8 = ft ³ /min 9 = ft ³ /s 10 = m ³ 11 = m ³ /h 12 = m ³ /min 13 = m ³ /s 14 = °F 15 = ft 16 = ft/h 17 = ft/min 18 = ft/s 19 = gal 20 = gal/h 21 = gal/min 22 = gal/s 23 = H 24 = Hz		3404h	5124	enum

Parameter	Description	Range of values	Decimal places	Index	Net Id	Size
		25 = HP 26 = h 27 = in 28 = lnWC 29 = K 30 = kg 31 = kgf 32 = kgf/cm ² 33 = kgf/m ² 34 = kl/h 35 = kPa 36 = kW 37 = kWh 38 = l 39 = l/h 40 = l/min 41 = l/s 42 = lbf 43 = mA 44 = mca 45 = m 46 = m/h 47 = m/min 48 = m/s 49 = mbar 50 = ms 51 = min 52 = MPa 53 = mwc 54 = N 55 = Nm 56 = Pa 57 = % 58 = psi 59 = rpm 60 = s 61 = V 62 = W 63 = W/m ² 64 = Wh/m ²				
C10.2.6	Dec. Point Eng. Unit 3	0 to 3	0	3405h	5125	8bit
C10.2.7	Engineering Unit 4	0 = No Unit 1 = A 2 = bar 3 = °C 4 = CPM 5 = CV 6 = ft ³ 7 = ft ³ /h 8 = ft ³ /min		3406h	5126	enum



Parameter	Description	Range of values	Decimal places	Index	Net Id	Size
		9 = ft ³ /s 10 = m ³ 11 = m ³ /h 12 = m ³ /min 13 = m ³ /s 14 = °F 15 = ft 16 = ft/h 17 = ft/min 18 = ft/s 19 = gal 20 = gal/h 21 = gal/min 22 = gal/s 23 = H 24 = Hz 25 = HP 26 = h 27 = in 28 = lnWC 29 = K 30 = kg 31 = kgf 32 = kgf/cm ² 33 = kgf/m ² 34 = kl/h 35 = kPa 36 = kW 37 = kWh 38 = l 39 = l/h 40 = l/min 41 = l/s 42 = lbf 43 = mA 44 = mca 45 = m 46 = m/h 47 = m/min 48 = m/s 49 = mbar 50 = ms 51 = min 52 = MPa 53 = mwc 54 = N 55 = Nm 56 = Pa 57 = % 58 = psi 59 = rpm				

Parameter	Description	Range of values	Decimal places	Index	Net Id	Size
C10.2.8	Dec. Point Eng. Unit 4	60 = s 61 = V 62 = W 63 = W/m ² 64 = Wh/m ² 0 to 3	0	3407h	5127	8bit
C11 Configurations\HMI						
C11.1	Configuration					
C11.1.1	Time Zone	0 = UTC-12:00 1 = UTC-11:30 2 = UTC-11:00 3 = UTC-10:30 4 = UTC-10:00 5 = UTC-09:30 6 = UTC-09:00 7 = UTC-08:30 8 = UTC-08:00 9 = UTC-07:30 10 = UTC-07:00 11 = UTC-06:30 12 = UTC-06:00 13 = UTC-05:30 14 = UTC-05:00 15 = UTC-04:30 16 = UTC-04:00 17 = UTC-03:30 18 = UTC-03:00 19 = UTC-02:30 20 = UTC-02:00 21 = UTC-01:30 22 = UTC-01:00 23 = UTC-00:30 24 = UTC+00:00 25 = UTC+00:30 26 = UTC+01:00 27 = UTC+01:30 28 = UTC+02:00 29 = UTC+02:30 30 = UTC+03:00 31 = UTC+03:30 32 = UTC+04:00 33 = UTC+04:30 34 = UTC+05:00 35 = UTC+05:30 36 = UTC+06:00 37 = UTC+06:30 38 = UTC+07:00 39 = UTC+07:30 40 = UTC+08:00 41 = UTC+08:30		20C4h	196	enum

Parameter	Description	Range of values	Decimal places	Index	Net Id	Size
		42 = UTC+09:00 43 = UTC+09:30 44 = UTC+10:00 45 = UTC+10:30 46 = UTC+11:00 47 = UTC+11:30 48 = UTC+12:00 49 = UTC+12:30 50 = UTC+13:00 51 = UTC+13:30 52 = UTC+14:00				
C11.1.2	Date/Hour	0 to 2147483647	0	20C2h	194	NONE
C11.1.3	Language	0 = Português 1 = English 2 = Español 3 = Deutsch 4 = Français 5 = Italiano 6 = Nederlands		20C9h	201	enum
C11.1.4	Display Brightness	0 to 100 %	0	20D8h	216	16bit
C11.1.5	Contrast	0 to 100 %	0	20D9h	217	16bit
C11.1.6	Inc./Dec. Parameter	0 = Disabled 1 = Speed Ref. via HMI 2 = Torque Reference via HMI 3 = PID Setpoint 4 ... 10 = Not used 11 = User Parameter 1 12 = User Parameter 2 13 = User Parameter 3 14 = User Parameter 4 15 = User Parameter 5 16 = User Parameter 6 17 = User Parameter 7 18 = User Parameter 8 19 = User Parameter 9 20 = User Parameter 10		20DAh	218	enum
C11.2	Main Screen					
C11.3	User					
C11.3.1	Login					
C11.3.2	Change password					
C12 Configurations\Backup						
C12.1	Load Parameters	0 = Not Used 1 = Default 60 Hz 2 = Default 50 Hz 3 = Param. Set 1 -> CFW 4 = Param. Set 2 -> CFW		20CCh	204	enum

Parameter	Description	Range of values	Decimal places	Index	Net Id	Size
		5 = Param. Set 3 -> CFW 6 = CFW -> Param. Set 1 7 = CFW -> Param. Set 2 8 = CFW -> Param. Set 3 9 = SD Card -> CFW 10 = CFW -> SD Card 11 = HMI -> CFW 12 = CFW -> HMI				
A1 Application\User Parameters A2 Application\PID Controller						
A2.1	Monitoring					
A2.1.1	Setpoint	-32768 to 32767	0	21F8h	504	s16bit
A2.1.3	Process Variable	-32768 to 32767	0	21F6h	502	s16bit
A2.1.5	Controller Output	0 to 60000 rpm	0	21FBh	507	16bit
A2.1.6	Logical Status	Bit 0 = Operation State Bit 1 = Sleep Mode Bit 2 = Automatic Mode Bit 3 = PV Low Level Alarm Bit 4 = PV Low Level Fault Bit 5 = PV High Level Alarm Bit 6 = PV High Level Fault		21FDh	509	7bit
A2.2	Regulation					
A2.2.1	Setpoint					
A2.2.1.1	Automatic Mode	-32768 to 32767	0	21FFh	511	s16bit
A2.2.1.2	Manual Mode	0 to 60000 rpm	0	220Dh	525	16bit
A2.2.1.3	Filter	0.000 to 9.999 s	3	2216h	534	16bit
A2.2.2	Gains					
A2.2.2.1	Proportional	0.00 to 99.99	2	2208h	520	16bit
A2.2.2.2	Integral	0.00 to 99.99	2	2209h	521	16bit
A2.2.2.3	Derivative	0.00 to 99.99	2	220Ah	522	16bit
A2.3	Configuration					
A2.3.1	Control					
A2.3.1.1	Action Control Selection	0 = Direct 1 = Reverse		220Fh	527	enum
A2.3.1.2	Sampling Period	0.050 to 9.999 s	3	220Bh	523	16bit
A2.3.2	Setpoint					
A2.3.2.1	Source Selection	0 = Parameter 1 = Analog Input 2 = Not used		2210h	528	enum
A2.3.3	Process Variable					
A2.3.3.1	Source Selection	0 = Analog Input 1 = Not used 2 = AI Differential		220Ch	524	enum
A2.3.3.2	Unit	1 to 7	0	2234h	564	NONE

Parameter	Description	Range of values	Decimal places	Index	Net Id	Size
A2.3.3.3	Decimal Places	0 = wxyz 1 = wxy.z 2 = wx.yz 3 = w.xyz		2238h	568	enum
A2.3.3.4	Minimum Level	-32768 to 32767	0	2218h	536	s16bit
A2.3.3.5	Maximum Level	-32768 to 32767	0	221Ah	538	s16bit
A2.3.4	Operating Mode					
A2.3.4.1	MAN/AUTO Source	0 = Parameter 1 = Selection via DI		2213h	531	enum
A2.3.4.2	MAN/AUTO Selection	0 = Manual 1 = Automatic		2214h	532	enum
A2.3.4.3	SP Automatic Setting	0 = Both SP Inactive 1 = Active Automatic SP 2 = Active Manual SP 3 = Both SP Active		2215h	533	enum
A2.3.5	Command Sources					
A2.3.5.1	AI for Setpoint	0 = Inactive 1 = AI X-1 2 = AI X-2 3 = AI A-1 4 = AI A-2 5 = AI A-3 6 = Not used 7 = AI B-1 8 = AI B-2 9 = AI B-3 10 = Not used 11 = AI C-1 12 = AI C-2 13 = AI C-3 14 = Not used 15 = AI D-1 16 = AI D-2 17 = AI D-3 18 = Not used 19 = AI E-1 20 = AI E-2 21 = AI E-3 22 = Not used 23 = AI F-1 24 = AI F-2 25 = AI F-3 26 = Not used 27 = AI G-1 28 = AI G-2		2227h	551	enum

Parameter	Description	Range of values	Decimal places	Index	Net Id	Size
A2.3.5.3	AI for Process Var. 1	29 = AI G-3 30 = Not used 0 = Inactive 1 = AI X-1 2 = AI X-2 3 = AI A-1 4 = AI A-2 5 = AI A-3 6 = Not used 7 = AI B-1 8 = AI B-2 9 = AI B-3 10 = Not used 11 = AI C-1 12 = AI C-2 13 = AI C-3 14 = Not used 15 = AI D-1 16 = AI D-2 17 = AI D-3 18 = Not used 19 = AI E-1 20 = AI E-2 21 = AI E-3 22 = Not used 23 = AI F-1 24 = AI F-2 25 = AI F-3 26 = Not used 27 = AI G-1 28 = AI G-2 29 = AI G-3 30 = Not used		2229h	553	enum
A2.3.5.4	AI for Process Var. 2	0 = Inactive 1 = AI X-1 2 = AI X-2 3 = AI A-1 4 = AI A-2 5 = AI A-3 6 = Not used 7 = AI B-1 8 = AI B-2 9 = AI B-3 10 = Not used 11 = AI C-1 12 = AI C-2 13 = AI C-3 14 = Not used 15 = AI D-1		222Ah	554	enum

Parameter	Description	Range of values	Decimal places	Index	Net Id	Size
		16 = AI D-2 17 = AI D-3 18 = Not used 19 = AI E-1 20 = AI E-2 21 = AI E-3 22 = Not used 23 = AI F-1 24 = AI F-2 25 = AI F-3 26 = Not used 27 = AI G-1 28 = AI G-2 29 = AI G-3 30 = Not used				
A2.3.5.6	DI for Manual/Automatic	0 = Inactive 1 = DI X-1 2 = DI X-2 3 = DI X-3 4 = DI X-4 5 = DI X-5 6 = DI X-6 7 = DI A-1 8 = DI A-2 9 = DI A-3 10 = DI A-4 11 = DI A-5 12 = DI A-6 13 = DI A-7 14 = DI A-8 15 = DI B-1 16 = DI B-2 17 = DI B-3 18 = DI B-4 19 = DI B-5 20 = DI B-6 21 = DI B-7 22 = DI B-8 23 = DI C-1 24 = DI C-2 25 = DI C-3 26 = DI C-4 27 = DI C-5 28 = DI C-6 29 = DI C-7 30 = DI C-8 31 = DI D-1 32 = DI D-2 33 = DI D-3 34 = DI D-4		222Ch	556	enum

Parameter	Description	Range of values	Decimal places	Index	Net Id	Size
		35 = DI D-5 36 = DI D-6 37 = DI D-7 38 = DI D-8 39 = DI E-1 40 = DI E-2 41 = DI E-3 42 = DI E-4 43 = DI E-5 44 = DI E-6 45 = DI E-7 46 = DI E-8 47 = DI F-1 48 = DI F-2 49 = DI F-3 50 = DI F-4 51 = DI F-5 52 = DI F-6 53 = DI F-7 54 = DI F-8 55 = DI G-1 56 = DI G-2 57 = DI G-3 58 = DI G-4 59 = DI G-5 60 = DI G-6 61 = DI G-7 62 = DI G-8				
A2.3.6	Faults and Alarms					
A2.3.6.1	Config. for PV Low Level	0 = Inactive 1 = Alarm 2 = Fault 3 = Alarm and Fault		221Fh	543	enum
A2.3.6.2	Value for PV Low Level	-32768 to 32767	0	2220h	544	s16bit
A2.3.6.3	Time for PV Low Level	0.0 to 999.9 s	1	2221h	545	16bit
A2.3.6.4	Config. for PV High Level	0 = Inactive 1 = Alarm 2 = Fault 3 = Alarm and Fault		221Ch	540	enum
A2.3.6.5	Value for PV High Level	-32768 to 32767	0	221Dh	541	s16bit
A2.3.6.6	Time for PV High Level	0.0 to 999.9 s	1	221Eh	542	16bit
A2.3.7	Sleep Mode					
A2.3.7.1	Sleep Mode Config.	0 = Disabled 1 = Enabled		2222h	546	enum
A2.3.7.2	PV Deviation to Wake up	-32768 to 32767	0	2223h	547	s16bit
A2.3.7.3	Time to Wake Up	0.0 to 999.9 s	1	2224h	548	16bit
A2.3.7.4	Speed for Sleep Mode	0 to 60000 rpm	0	2225h	549	16bit

Parameter	Description	Range of values	Decimal places	Index	Net Id	Size
A2.3.7.5	Time for Sleep Mode	0.0 to 999.9 s	1	2226h	550	16bit





WEG Drives & Controls - Automação LTDA.
Jaraguá do Sul – SC – Brazil
Phone 55 (47) 3276-4000 – Fax 55 (47) 3276-4020
São Paulo – SP – Brazil
Phone 55 (11) 5053-2300 – Fax 55 (11) 5052-4212
automacao@weg.net
www.weg.net