

Smoke Extraction Motors

Installation, Operation and Maintenance Manual

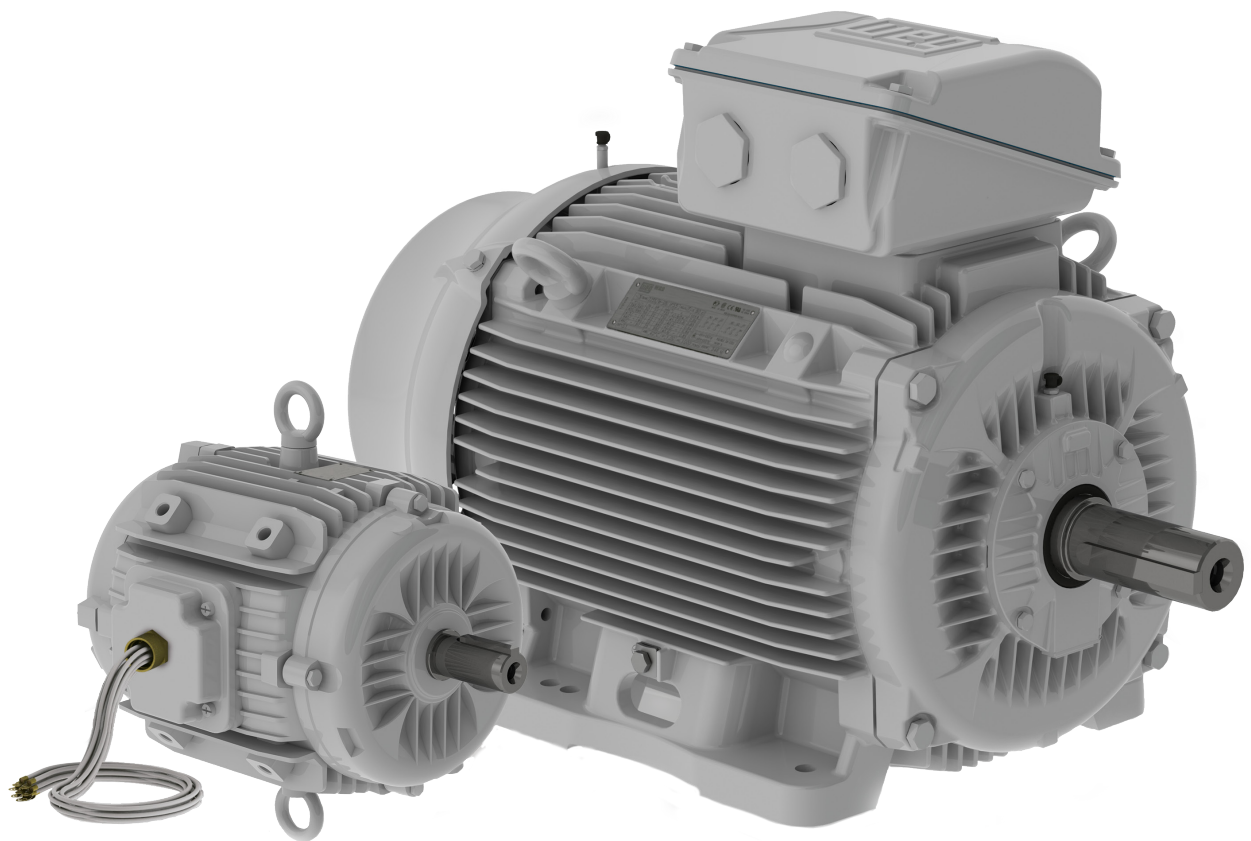

Installation, Operation and Maintenance Manual

Smoke Extraction Motors

Language: English

Document: 50026367

Revision: 08

Date: 04/2026

1 INTRODUCTION	1-1
1.1 SAFETY INFORMATION.....	1-1
2 VALIDITY	2-1
3 CONFORMITY	3-1
4 RECEVEING, HANDLING AND STORAGE	4-1
4.1 SAFETY INSTRUCTIONS.....	4-1
4.2 HANDLING AND TRANSPORT	4-1
5 INSULATION RESISTANCE	5-1
6 ABSORPTION AND POLARIZATION INDEX.....	6-1
7 INSTALLATION.....	7-1
7.1 COOLING.....	7-1
8 MECHANICAL ASPECTS.....	8-1
9 ELECTRICAL ASPECTS	9-1
9.1 SUPPLY SYSTEM	9-1
9.2 CABLES CONNECTION.....	9-1
10 STARTING	10-1
10.1 NUMBER OF STARTS	10-1
10.2 DIRECTION OF ROTATION.....	10-1
11 PROTECTION	11-1
11.1 ELECTRICAL PROTECTION	11-1
11.2 OVERHEATING PROTECTION	11-1
11.3 WINDING TEMPERATURE LIMITS.....	11-1
11.4 BEARING TEMPERATURE LIMITS.....	11-2
12 COMMISIONING	12-1
12.1 PRELIMINARY INSPECTION	12-1
13 MAINTENANCE	13-1
14 WINDING LIFE	14-1
15 LUBRIFICATION	15-1
15.1 SHIELDD/SEALED BEARINGS	15-1
15.2 MACHINES FITTED WITH GREASE NIPPLES.....	15-1
15.3 LUBRIFICATIONS INTERVALS	15-1
15.4 QUALITY AND AMOUNT OF GREASE.....	15-2
15.5 GREASE COMPATIBILITY.....	15-2
15.6 DRIVE END AND NON-DRIVE END BEARING RELUBRICATION STEPS.....	15-2

SUMMARY

16 EXTERNAL/INTERNAL MAINTENANCE	16-1
16.1 CLEANLINESS.....	16-1
16.2 PARTIAL MAINTENANCE	16-1
16.3 SPARE PARTS.....	16-1
17 ABNORMAL SITUATIONS DURING OPERATION	17-1
17.1 COMMON FAILURES ON SMOKE EXTRACTION MOTORS	17-1
18 TROUBLESHOOTING CHART X SOLUTIONS.....	18-1

Dear Customer.

The electric motor is an item of equipment widely used by man in industrial development, considering that most of the machines he has been inventing depend upon it. Taking into consideration the prominent role the electric motor plays in people's lives', it must be regarded as a prime power unit embodying features that require special care including its installation and maintenance in order to ensure perfect operation and extended lifetime of the unit. This INSTALLATION, OPERATION AND MAINTENANCE MANUAL intends to assist those who deal with electric machines facilitating their task to preserve the most important item of the unit:

The ELECTRIC MOTOR.

**ATTENTION!**

Read carefully the instructions included in this manual in order to ensure a safe and reliable operation of the equipment.

**ATTENTION!**

This manual is complementary with general IOM - Installation, Operation and Maintenance Manual of Electric Motors - 50031142 and 50033244. When the same issues are addressed in both documents, instructions given in this document will prevail.

WEG Equipamentos Elétricos. S.A - MOTORES.

1 INTRODUCTION**NOTE!**

These instructions must be followed to ensure safe and proper storage, installation, operation and maintenance of the motor. The Fan OEM's and End Users should bring these instructions to the attention of anyone who installs, operates or maintains this equipment. Ignoring the instruction may invalidate the warranty. In case you still have further doubts, please contact WEG.

**ATTENTION!**

All standard and procedures included in this manual must be followed accordingly to ensure proper and reliable operation or storage of the equipment as well as to ensure safety conditions to the personnel involved in the motor operation. Following these procedures is also important for the warranty policy as explained at the end of this manual.

1.1 SAFETY INFORMATION

Additional information about installation, operation, and maintenance of electrical equipment:

QUALIFIED PERSONNEL is those people (OEM and end user) who based on their education, experience, knowledge of standards and service conditions required are properly authorized to perform any service on the motor. The qualified personnel must read and have this document in mind and they need to know all cares and procedures mentioned here. Furthermore, these people should know how to carry out first aid procedures.

If you still have further doubts about this, especially in reference to specific product information, WEG is willing to provide such information.

**ATTENTION!**

If this Installation, Operation and Maintenance Manual is lost, a replacement copy can be provided upon request, alternatively this can be downloaded online from the WEG website www.weg.net If required, WEG is prepared to assist you with any further doubts you may have; in this case, the motor serial number should also be advised.

INTRODUCTION

In order to allow WEG to provide prompt service within technical standards, the motor serial number detailed on the motor nameplate should be advised. Aiming at a satisfactory motor performance, we suggest making the storage, installation, commissioning, start-up and maintenance plan before receiving the equipment.

**ATTENTION!**

To prevent eventual motor operating problems, we recommend that all maintenance and revision services described in this Installation, Operation and Maintenance Manual be carried out by duly trained personnel. Changes of rated operating characteristics, such as excess demand for energy, temperature, and noise level increase, abnormal smell and tripping of protections are the first signs of any abnormal occurrence. In this case, to avoid material damage or injury to people, maintenance people should be immediately informed about such circumstances.

**ATTENTION!**

In case of doubt, switch off the motor immediately!

2 VALIDITY

These instructions are valid for WEG Smoke Extraction Motor line.

**ATTENTION!**

The Warranty Terms will be presented at the end of this manual, but these terms will be valid only if the criteria and recommendations informed in this manual have been followed in their entirety as well as the motor design has not been changed, otherwise, the terms will be invalid.

3 CONFORMITY

WEG Smoke Extraction Motors comply mechanically and electrically with the requirements laid down European Standard – EN12101-3 (Specification for powered smoke and heat exhaust ventilators).

Motors in conformity with this standard are able to provide daily ventilation, as well as for driving smoke extraction fans in a fire/emergency condition. In fire emergency condition, they must be effective in creating a smoke-free area near the floor allowing possible evacuation and rescue of people and animals, as well as ensuring property protection and allowing that fires could be fought in their initial stages. These systems also help to eliminate hot gases produced by combustion in the first stages of the fire.

**ATTENTION!**

Since their operation will be vital in the event of an accident, WEG recommend performing additional surveillance and maintenance operation as mentioned in this manual. In order to ensure their perfect operation, a safety function is required.

4 RECEIVING, HANDLING AND STORAGE

4.1 SAFETY INSTRUCTIONS

Always follow the safety, installation, maintenance and inspection instructions in accordance with the applicable standards in each country.

**ATTENTION!**

The motor must be disconnected from the power supply and be completely stopped before conducting any installation or maintenance procedures. Additional measures should be taken to avoid accidental motor starting.

**ATTENTION!**

Electric motors have energized circuits, exposed rotating parts and hot surfaces that may cause serious injury to people during normal operation. It is recommended that transportation, storage, installation, operation and maintenance services are always performed by qualified personnel.

**ATTENTION!**

Pacemaker users and unqualified personnel shall not open WMagnet and WQuattro motors, because high energy magnets are used.

**ATTENTION!**

Professionals working with electrical installations, either in the assembly, operation or maintenance, should use proper tools and be instructed on the application of standards and safety requirements, including the use of Personal Protective Equipment (PPE) that must be carefully observed in order to reduce risk of personal injury during these services.

4.2 HANDLING AND TRANSPORT

Individually packaged motors should never be lifted by the shaft or by the packaging. They must be lifted only by means of the eyebolts, when supplied. Use always suitable lifting devices to lift the motor. Eyebolts on the frame are designed for lifting the machine weight only as indicated on the motor nameplate. Motors supplied on pallets must be lifted by the pallet base with lifting devices fully supporting the motor weight. The package should never be dropped. Handle it carefully to avoid bearing damage. Handle the motor carefully without sudden impacts to avoid bearing damage and prevent excessive mechanical stresses on the eyebolts resulting in its rupture. If the motor is not installed immediately, it must be stored in a dry and clean environment, with relative humidity not exceeding 60 %, with an ambient temperature between -25 °C and 60 °C, without sudden temperature changes, free of dust, vibrations, gases or corrosive agents.

**ATTENTION!**

Eyebolts provided on the frame are designed for lifting the machine only. Do not use these eyebolts for lifting the motor with coupled equipment such as bases, pulleys, pumps, reducers, etc..
Never use damaged, bent or cracked eyebolts. Always check the eyebolt condition before lifting the motor.

**ATTENTION!**

Do not handle the motors by the polymeric components: fan cover, drip cover, terminal box and / or terminal box cover.

RECEIVING, HANDLING AND STORAGE



ATTENTION!

To move or transport motors with cylindrical roller bearings or angular contact ball bearings, use always the shaft locking device provided with the motor. All HGF, W50, W51 HD and W60 motors, regardless of bearing type, must be transported with shaft locking device fitted. Vertical mounted motors with oil-lubricated bearings must be transported in the vertical position. If necessary to move or transport the motor in the horizontal position, install the shaft locking device on both sides (drive end and non-drive end) of the motor.



ATTENTION!

The receiving, handling and storage of the motor must follow the orientations presented on General IOM 50031142 and 50033244.

Bearings

Motors equipped with roller bearings: WEG recommends to run these motors with a minimum radial force in order to avoid bearings damage (consult WEG in case of doubts).

Motors equipped with angular contact bearings: WEG recommends to run these motors with the appropriate axial force in the correct direction in order to avoid bearings damage.

5 INSULATION RESISTANCE

When the motor is not installed immediately, it should be protected against moisture, heat, and dirt in order to avoid insulation resistance reduction. If the motor is stored in rooms with moisture, insulation resistance must be measured at periodical intervals.

**ATTENTION!**

Measure the insulation resistance before the motor starting.

**DANGER!**

To avoid electric discharge risks, discharge the terminals right after performing the measurement.

It is difficult for determining rules for the current insulation resistance value of a motor since its resistance may change from type to type, size, rated voltage, condition of the used insulating material and motor construction method. A lot of experience is required to decide when the motor is ready for operation. Periodical records will be helpful to take the correct decision.

The minimum recommended insulation resistance value is 100 MOhms.

If the test is performed at a different temperature than 40 °C, it is necessary to correct the reading to 40 °C (as shown on the [Figure 5.1 on page 5-2](#)) by using an insulation resistance variation curve in relation to temperature, given by the motor itself. If this curve is not available, it is possible to use an approximate correction given by the characteristic curve. ([Figure 5.1 on page 5-2](#)).

On new motors, lower resistance values are sometimes obtained, since solvents are present in the insulating varnishes, which become volatile in a later stage during normal operation. This does not necessarily mean that the motor is not suitable for operation considering that the insulation resistance will increase after a period of operation.

On old motors, still in operation, higher resistance values are normally obtained. The comparison with values obtained from previous tests on the same motor under identical voltage, temperature and moisture conditions will be a good indicator of the insulation conditions in comparison to the value obtained from a single test. Any sudden or high reduction of the resistance requires careful evaluation.

INSULATION RESISTANCE

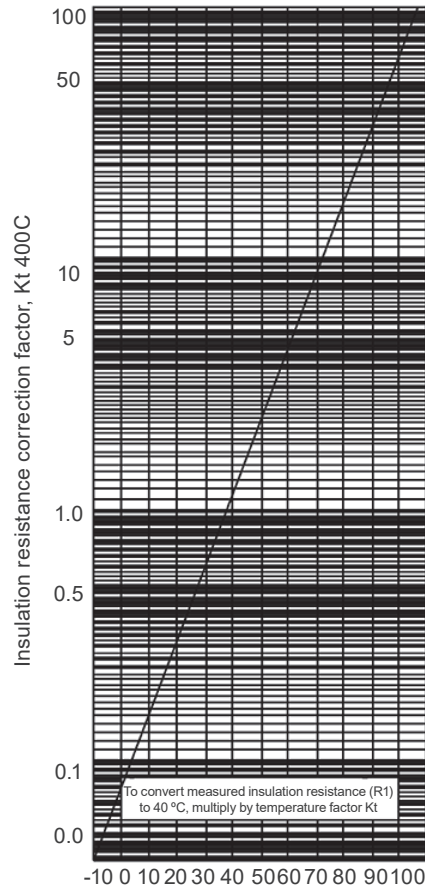

Figure 5.1: Variation of insulation resistance with the temperature. Winding temperature (°C) $R_{40°C} = R_t \times K_t$

6 ABSORPTION AND POLARIZATION INDEX

In addition to the insulation resistance measurement, WEG also recommends the absorption and polarization index test. The polarization index is the ratio of the 10 min insulation resistance to the 1 min insulation resistance. The absorption index is the ratio between the 1 min insulation resistance to the 0,5 min insulation resistance.



ATTENTION!

To avoid electric discharge risks, discharge the terminals right after performing the measurement.

Table 6.1: Guideline for the motor winding evaluation

IR	IP (Only for Motors >11 kW)	IA	Recommendations	Conditions
> 500M	IP >2	IA > 1.2	The motor can run. As the current lack levels are very low at these insulation resistance values, the index turns very inaccurate	Released
	1 < IP < 2	1 < IA < 1.2		
	IP < 1	IA < 1		
500M > IR > 100M	IP >2	IA > 1.2	The motor can run	Released
	1 < IP < 2	1 < IA < 1.2	Evaluate why the index is very low. If external causes are identified, the motor can run. Otherwise, it is required to run another test and check the index tendency	Released with reservation
	IP < 1	IA < 1	It is necessary to wash and dry the motor in an oven and evaluate the index again. If the index remains low, it is necessary to repeat the process. If it still is not good, see the notes	Evaluate the using
100M > IR > 5M	IP >2	IA > 1.2	The motor can run	Released
	1 < IP < 2	1 < IA < 1.2	It is necessary to wash and dry the motor in an oven (100 °C/ 2 h) and evaluate the index again. If the index is better than before, this process must be repeated until a good value is obtained. If this is not achieved, see notes	Evaluate the using
	IP < 1	IA < 1	To wash and dry the motor winding and evaluate the index. If the values are still low, see notes	It is necessary to repair
< 5 M	IP >2	IA > 1.2	To wash and dry and evaluate the index. If the values are still low, see notes	It is necessary to repair
	1 < IP < 2	1 < IA < 1.2		
	IP < 1	IA < 1		

Legend: IR: Insulation Resistance.
IP: Polarization Index.
IA: Absorption Index.

The combination of the insulation resistance, polarization index, and absorption index results will give a better answer than only the insulation resistance evaluation. [Table 6.1 on page 6-1](#), shows this combination and the conditions/ results. If the index results are in conflicting, it must be chosen the worst case.

The tests must be realized in controlled temperature and moisture or in known conditions. This table shall be used as a guide and is based on site experience. According to IEEE 43, the test may not apply to small random winding machines since the absorption current becomes negligible in a matter of seconds. When the IR1 (insulation resistance reading obtained after the voltage has been applied for 1 min) is higher than 5000 MΩ the Polarization Index may or may not be an indication of the insulation condition and is therefore not recommended as an assessment tool.

7 INSTALLATION

Smoke Extraction Motors were not designed to operate in hazardous location, like explosive atmosphere.



ATTENTION!

The locations where the motors are installed should allow easy access for inspection and maintenance services. WEG is not liable for removing motors from the site.



ATTENTION!

Install cable glands to protect the main and accessories lead wires. Handle these leads carefully in order to avoid insulation damages on leads and cable in general.

In case of replacement of the original cable gland, it shall be guaranteed the complete protection of the cables, avoiding contact with the machining of the thread. WEG recommends using a cable gland with a thread 2 mm [0.07 in] longer the base plate thickness.

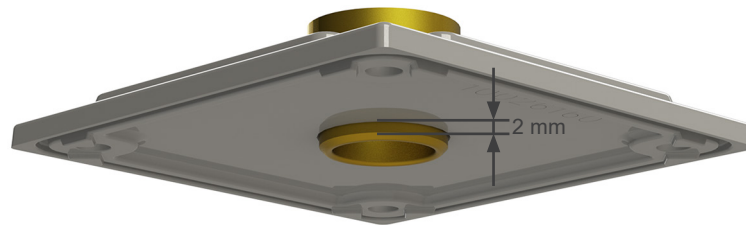

Figure 7.1: Cable gland



ATTENTION!

The cables must be fixed using the appropriate cable glands. Loose cables can be damage due to air flow.

In case of replacement of the original cable gland, it shall be guaranteed the complete protection of the cables, avoiding contact with the machining of the thread. WEG recommends using a cable gland with a thread 2 mm [0.07 in] longer the base plate thickness.



ATTENTION!

Bearings are sensitive to standstill vibration or impacts caused during handling.



ATTENTION!

The cable connection from the motor terminal box to the power supply must be carried out using cable glands and conduit in order to guarantee mechanical protection of the cables against dirt and dust that could damage the insulation of the cables during motor operation. All components must be suitable for operation at the emergency temperature condition.

7.1 COOLING

Smoke Extraction Motors are designed to operate in a maximum ambient temperature of 40 °C and a maximum altitude of 1000 m [39.37 in] above sea level (unless otherwise specified as part of the Contract).

Ensure that no nearby equipment, surfaces or direct sunshine, radiate additional heat on to the motor. To ensure free air circulation around the motor, TEFC (Totally Enclosed Fan Cooled) machines must not be mounted nearer than 1/4 of the air inlet diameter to walls or other obstructions. See below example of a 200 frame motor.

INSTALLATION



ATTENTION!

Under no circumstance, motors can be enclosed in boxes or covered with materials which may obstruct or reduce the free cooling air circulation.

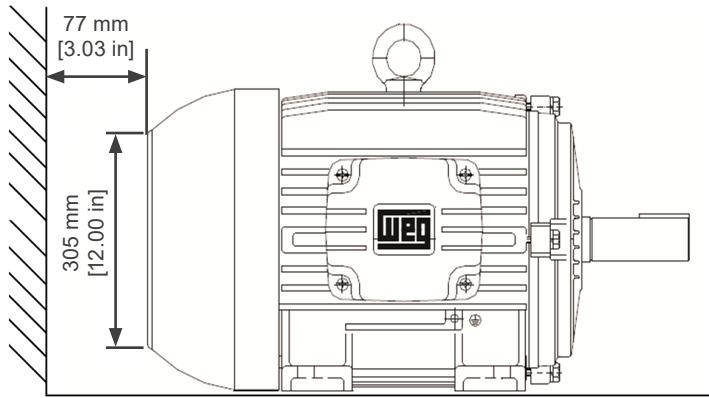

1/4 of 305 mm = around 77 mm

Figure 7.2: XXXXXX



ATTENTION!

Some smoke extraction motors used inside axial flow fans or similar are supplied without any self ventilation as they receive their cooling from the driven fan. There are designated TEAO (Totally Enclosed Air Over – IC 418).

Find below an illustration of TEAO motor.

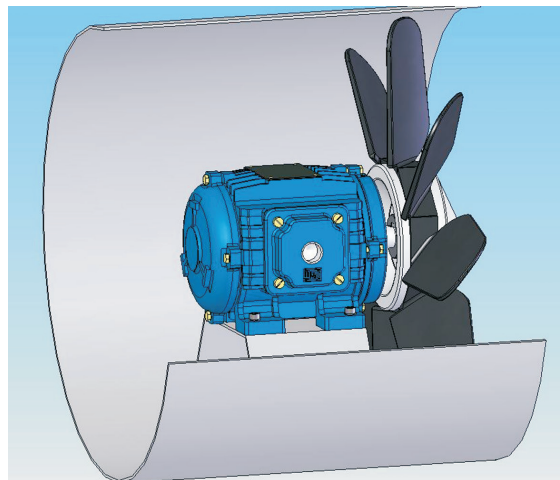

Figure 7.3: TEAO motor

Table 7.1 on page 7-3 shows the minimum air velocities required to cool TEAO fan and exhaust/smoke extraction motors considering IEC outputs only (ratings according to the main nameplate).

Table 7.1: Minimum required air velocities passing across motor cooling fins to achieve IEC ratings

Minimum Air Speeds Required to Cool Three-Phase - TEAO Motors								
W21 & W22 Standard Fan & Exhaust / Smoke Extraction Lines								
IEC Ratings (Standard Outputs)								
Frame	II Poles		IV Poles		VI Poles		VIII Poles	
	3000 rpm	3600 rpm	1500 rpm	1800 rpm	1000 rpm	1200 rpm	750 rpm	900 rpm
	Speed	Speed	Speed	Speed	Speed	Speed	Speed	Speed
	m/s	m/s	m/s	m/s	m/s	m/s	m/s	m/s
63	7.9	9.5	4.0	4.8	2.6	3.1	2.0	2.4
71	10.4	12.5	5.2	6.2	3.5	4.2	2.6	3.1
80	8.8	10.6	4.6	5.5	3.1	3.7	2.3	2.8
90	10.1	12.1	5.0	6.0	3.7	4.4	2.7	3.2
100	15.7	18.8	7.9	9.5	5.3	6.4	3.9	4.7
112	14.0	16.8	9.2	11.0	6.1	7.3	4.6	5.5
132	16.8	20.1	9.9	11.9	6.8	8.2	5.1	6.1
160	11.3	13.6	8.4	10.1	5.6	6.7	4.2	5.0
180	10.6	12.7	10.1	12.1	6.7	8.0	5.0	6.0
200	12.8	15.4	11.3	13.6	7.5	9.0	5.6	6.7
225	24.9	29.9	15.4	18.5	13.6	16.3	10.2	12.2
250	24.4	29.3	15.5	18.6	13.6	16.3	10.2	12.2
280	17.5	21.0	15.5	18.6	15.1	18.1	11.3	13.6
315S/M	19.1	22.9	15.2	18.2	16.3	19.6	12.2	14.6
315L	19.1	22.9	20.8	25.0	16.3	19.6	12.2	14.6
355M/L	17.8	21.4	21.0	25.2	19.6	23.5	14.7	17.6
355A/B	20.5	24.6	21.0	25.2	19.6	23.5	14.7	17.6

Table 7.2 on page 7-4 shows the minimum air velocities required to cool TEAO fan and exhaust/smoke extraction motors considering AOM 'air over motor' outputs (higher ratings according to the separate tag nameplate).

INSTALLATION

Table 7.2: Minimum required air velocities passing across motor cooling fins to achieve AOM ratings

Minimum Air Speeds Required to Cool Three-Phase - TEAO Motors								
W21 & W22 Standard Fan & Exhaust / Smoke Extraction Lines								
AOM Ratings (High Outputs)								
Frame	II Poles		IV Poles		VI Poles		VIII Poles	
	3000 rpm	3600 rpm	1500 rpm	1800 rpm	1000 rpm	1200 rpm	750 rpm	900 rpm
	Speed	Speed	Speed	Speed	Speed	Speed	Speed	Speed
	m/s	m/s	m/s	m/s	m/s	m/s	m/s	m/s
63	11.9	14.3	6.0	7.2	3.9	4.7	3.0	3.6
71	15.6	18.7	7.8	9.4	5.3	6.4	3.9	4.7
80	13.2	15.8	6.9	8.3	4.7	5.6	3.5	4.2
90	15.2	18.2	7.5	9.0	5.6	6.7	4.1	4.9
100	23.6	28.3	11.9	14.3	8.0	9.6	8.0	9.6
112	21.0	25.2	13.8	16.6	9.2	11.0	9.0	10.8
132	25.2	30.2	14.9	17.9	10.2	12.2	10.2	12.2
160	17.0	20.4	12.6	15.1	8.4	10.1	6.3	7.6
180	20.0	24.0	16.0	19.2	10.0	12.0	7.5	9.0
200	23.0	27.6	17.0	20.4	11.3	13.6	8.4	10.1
225	30.0	36.0	23.1	27.7	20.4	24.5	15.3	18.4
250	30.0	36.0	23.3	28.0	20.4	24.5	15.3	18.4
280	26.3	31.6	23.3	28.0	22.7	27.2	17.0	20.3
315S/M	28.7	34.4	22.8	27.4	24.5	29.4	18.3	22.0
315L	28.7	34.4	31.2	37.4	24.5	29.4	18.3	22.0
355M/L	26.7	32.0	31.2	37.4	29.4	35.3	22.1	26.5
355A/B	30.7	36.8	31.2	37.4	29.4	35.3	22.1	26.5

8 MECHANICAL ASPECTS

Correct mounting, balancing, coupling, leveling, alignment and vibration levels of the motor are important to guarantee and extend the motor's useful life, avoiding premature failures. For these items, follow the recommendations described in GENERAL IOM - Installation, Operation and Maintenance Manual of Electric Motors - 50031142 and 50033244.

**ATTENTION!**

To avoid vibration, the fan impeller/driven equipment shaft must be balanced with a half key.

**ATTENTION!**

Failure to provide the minimum air velocities indicated in [Table 7.1 on page 7-3](#) and [Table 7.2 on page 7-4](#) and for the required directions(s) of rotation, can result in an increased temperature rise or overheating, leading to premature failure of the insulation system.

9 ELECTRICAL ASPECTS

9.1 SUPPLY SYSTEM

A table electric power supply is very important. All the wires and protection system must ensure an excellent quality of electric power supply to the motor terminals, following the IEC60034-1.

9.2 CABLES CONNECTION

**ATTENTION!**

WEG recommends checking the specific lead connection diagram indicated on the main motor nameplate by noting the correct lead identification. If the motor is fitted with accessories (like temperature sensors, space heaters, etc.), check the motor auxiliary nameplate which contains the required information and cable identification.

For supply cable connection, remove terminal box cover.

Insert the cables into the terminal box. Cut the supply cables to the desired length, and crimp the terminals on them and make the connection on motor. Connect the cable shielding (if any) to the common grounding system. Cut the grounding cable to size crimp terminal on it and connect it to the existing grounding terminal inside the terminal box and/or frame. Fasten all connections firmly.

**ATTENTION!**

The motor must be ground to a good grounding system.

10 STARTING

The starting method is defined during the design step.

10.1 NUMBER OF STARTS

The motors are designed according to the predefined duty cycle. The motor duty indicates how many starts are allowed per hour, without damage the motor winding.

**ATTENTION!**

These overheating protection devices (temperature sensor) must be connected to an appropriate panel for signaling or motor switching off during abnormal motor operation. If not used, the warranty may be void.

10.2 DIRECTION OF ROTATION

Motors are usually designed for both directions of rotation. However, sometimes there may be additional nameplate indicating the direction of rotation that the motor must run.

Special attention must be given to the mechanical design, since components, like bearings (for example angular contact) may be designed according to the direction of rotation.

**ATTENTION!**

- Direction of rotation must be indicated on fan equipment and there can be noted also when equipment is designed for only one direction of rotation.
- Motor cooling must be according to [Table 7.2 on page 7-4](#) regardless of the direction of rotation.

11 PROTECTION

11.1 ELECTRICAL PROTECTION

Thermal protection is not fitted as standard to Smoke Extraction Motors. In this way, this section must be used just when thermal protection is fitted. Motors usually use two types of protection: protection against overload/locked rotor, and short circuits (protection of the installation). When the motor is designed for factor different than 1.0 (SF), the current of thermal relay protection must be set accordingly.

11.2 OVERHEATING PROTECTION

In case of a drop of voltage, overvoltage, inadequate motor ventilation, etc, the temperature sensors may switch off the motor due overheating.



ATTENTION!

These overheating protection devices (temperature sensor) must be connected to an appropriate panel for signaling or motor switching off during abnormal motor operation. If not used, the warranty may be void.



ATTENTION!

The temperature sensors control must be turned-off under emergency conditions in order to ensure that the motors can operate under the specified time/temperature conditions for which it has been supplied.

When the motor is fitted with temperature sensors, they will be indicated on the motor auxiliary nameplate. These nameplates contain the respective cable identification.

11.3 WINDING TEMPERATURE LIMITS

The temperature of the hottest winding point must be kept below the maximum insulation class temperature.

The total temperature corresponds to the sum of ambient temperature plus temperature rise (ΔT) plus the difference between the average temperature of the winding and the hottest point. The temperature values and the permissible total temperature at the hottest point are given in the [Table 11.1 on page 11-1](#).

Table 11.1: Material insulation class and temperature

Insulation Class		F	H
Ambient temperature	°C	40	40
Difference between the hottest point and the average temperature of the winding	°C	10	10
Maximum running temperature	°C	130	155
Maximum temperature material support	°C	155	180

The Smoke Extraction Motors must be operated at temperature rise one class below than motor insulation system. For instance, if the motor is designed with class H insulation system (180 °C), the maximum allowed temperature rise of this motor will be 105 K. So all temperature protection must be set accordingly. Derating conditions or use with a frequency inverter (for motors not specified for this condition) are critical for operation. Please contact WEG in case of necessity.

Thermistors (PTC)

The thermistor is temperature sensing elements composed of semiconductor material (PTC) which exhibit a large change in resistance proportional to a small change in temperature (setpoint). They are serial connected or independent according to the connection diagram.

PROTECTION



NOTE!

Thermistors must be connected to a control unit that cuts off the motor power supply or switches on an alarm system as a response of the thermistors reaction. WEG can provide proper relay for this function if requested.

RTD (PT100)

The Resistance Temperature Detectors is not set to only one temperature like thermistors since it has a range of resistance according to the temperature value.



NOTE!

PT100 is connected to a temperature control unit that monitors the temperature. The control switches off the motor power supply or switches on an alarm according to the set temperature.

PT100 have usually two leads, but sometimes they can be fitted with three or four leads to compensate for the distance (resistance effect) between the motors and control panel. If the motor is fitted with thermistors, the sensor is already set to a specific temperature that depends on the material insulation class. When PT100 is used to turn off the motor, we recommend using the same value of the maximum insulation temperature class according to [Table 7.2 on page 7-4](#). When used as an alarm, you can reduce the value by 15 °C, as the example below:

Using PT100 - In the windings (Class H - 180 °C):

Alarm temperature: 140 °C.

Trip temperature: 155 °C.

11.4 BEARING TEMPERATURE LIMITS

Find below the recommended temperature to alarm and motor turn-off, based on the bearings temperature. These temperatures do not depend on the winding insulation class.

Bearing temperature:

Alarm temperature: 110 °C.

Trip temperature: 120 °C.

The alarm and tripping temperatures can be set to different values based on experience. However, they cannot exceed the values indicated above.



ATTENTION!

In the emergency condition, any overheating protection device must be switched off.

12 COMMISSIONING

12.1 PRELIMINARY INSPECTION

Before starting the motor for the first time, check the following items:

- 1) Is the motor clean? Were all packing materials and cleaning materials removed?
- 2) Make sure the supply voltage and VFD match those indicated on the nameplate.
- 3) Make sure that all fixing bolts from the motor are firmly tightened.
- 4) Make sure the motor is correctly aligned.
- 5) Are the bearings lubricated correctly?
- 6) Are the thermal sensors, the grounding terminal, and the space heaters connected?
- 7) Is the measured stator insulation resistance according to the prescribed value ($IR \geq 100 \text{ M}\Omega$)?
- 8) Are all objects such as tools, measuring instruments and alignment devices removed from the area of the motor?
- 9) When the motor is started without load, does it rotate freely without abnormal noise? Is the direction of rotation correct? (To reverse the rotation, invert any of two terminal leads of the power supply).
- 10) Is the air ventilation passing on the motor?
- 11) Are all required motor protection (like fuses, thermal relay, etc.) on?



ATTENTION!

The non-observation of the items described above can lead to serious problems to motor performance, overheating and possible motor winding damage. These problems are not covered under the warranty terms included in this manual.

In order to ensure good motor conditions during the running time, follow recommended start-up checklist below:

- Motors features: Tag, frame, serial number, rpm, mounting, power, voltage and current.
- Visual inspection: cleanliness, terminal box, terminal block, leads cables, space heaters and sensors leads, terminals, eye bolts, fan and fan cover, couplings, fittings and drain plug.
- Space heater value: measure the space heater resistance (use the power and voltage indicated on space heater auxiliary nameplate for measuring the expected resistance value).
- Type of alignment: what type was used (clock – radial/radial; clock – radial/axial; optical; rule to pulleys).
- Alignment values: radial (...mm) and axial (...mm).
- Type of start: DOL, Soft-Starter, frequency inverter, etc... (Model, capacity, etc.).
- Voltage: measure the voltages between phases and check to the tolerance according to IEC60034-1.
- Unbalance Voltage: calculate the voltage unbalance according to IEC60034-26 and check if it is OK.
- Current: check the current in each phase and compare it with nameplate one.
- Current Unbalance: calculate the current unbalance according to IEC60034-26 and check if it is OK.
- Speed: check the speed (rpm).

COMMISSIONING

- Ambient Temperature: measure the ambient temperature at a distance of 1 m [39,37 in] from the motor.
- Altitude: determine site altitude.
- Air flow speed: check if the TEO motor is receiving the necessary air speed as recommended. If the motor is a TEFC, ensure that motor supplies the required cooling air over the motor fins.
- Bearings housing temperature: D.E and N.D.E temperature.
- Winding temperature: check if the winding temperature is according to its insulation class limit.
- Vibration values: check the vibration on all of 6 points (if possible), as recommended by standard, at the D.E and N.D.E bearing. Check also acceleration.
- Final condition: approved or not approved, and who is approving.
- General observation: all of the details that were verified during the start-up.



NOTE!

WEG recommends measuring the motor temperature (bearings, winding, if possible) within 6 hours (in intervals of 15 minutes). This time is required for motor reach the thermal equilibrium.



ATTENTION!

SHUTDOWN PROCEDURE - Before proceeding any task, switch-off the motor, since there are moving part and hot surfaces that may cause serious injurious.

13 MAINTENANCE

Well-Programmed maintenance of electric motors can be summed up as a periodical inspection (like 7 days, 15 days, 1 month, 1,5 month, 3 months, 6 months, etc...). WEG recommends that the following procedure should be followed:

- Cleanliness (fins, fan cover, etc...).
- Current and Voltage.
- Bearings and Windings temperature.
- Ambient temperature.
- Vibration levels.
- Seals conditions (V'ring, taconite, oil seal, etc...).
- Wears in general.
- Noisy.
- Lubrication conditions and useful life (listed on a specific topic).
- Connections conditions.
- Screw tightness in general.
- Winding life (listed in a specific topic).
- Insulation resistance.
- Etc...

In case one of the above items are not met accordingly, you might have unexpected stops of the equipment.

Inspection cycles depend upon conditions under which the motor operates (safety and production). These procedures ensure long motor life if followed correctly.

In order to ensure proper cooling, the motor frame should be kept clean, free of dust, dirt or oil.

MAINTENANCE

Table 13.1: Recommended Maintenance Schedule for a motor operating continuously

Component	Weekly	Every 3 Months	Yearly (Partial Maintenance)	Every 3 Years (Complete Maintenance)
Complete motor	Check if there is abnormal noise	Drain condensed water (if any) Check vibration levels	Retighten the bolts	Dismantle the motor. Check spare parts
Stator Winding			Visual inspection. Measure insulation resistance (**)	Cleanliness: check the fastenings and the slot edges; measure the insulation resistance (**), the absorption and the polarization index (***)
Bearings		Check and relubricate for intervals see the data on the nameplate		Clean the bearings. Replace them, if required
Terminal boxes and grounding lugs			Clean the inside area and retighten the bolts	Clean the inside area and retighten the bolts
Coupling: follow maintenance instructions specified in the coupling manufacturer manual	After the first week of operation: check the fastening, vibration and temperature		Check the fastening, vibration and temperature	Check the fastening, vibration and temperature
Monitoring devices	Record the measuring values			If possible, disassemble and check its operating condition

(**) Minimum insulation resistance 100 Mohm (500VDC).

(***) According to [Chapter 6 ABSORPTION AND POLARIZATION INDEX on the page 6-1](#).



NOTE!

This maintenance schedule is recommended for a motor in continuous duty (S1) and not for a motor operating in emergency conditions only (S2).



ATTENTION!

Following the use of the motor under emergency conditions it must be replaced with a new motor. The motor will no longer be suitable to operate in its safety operation condition.



ATTENTION!

After each maintenance procedures when the motor is opened, it is advised to replace the seals and if the motor is fitted with labyrinth taconite or W3-Seal, apply new grease on the labyrinth as bearings grease indicated on the nameplate.

14 WINDING LIFE

SMOKE Extraction motors are designed to operate with insulation class H and temperature rise class B. In this condition, the lifetime of winding is 25 years from the manufacturing date if respecting the temperature rise limits, conducting periodical inspections through well-programmed maintenance as described in this manual and maintaining installation reliability. In case of any abnormal behavior of electrical and/or mechanical parameters are identified, the motor shall be replaced.

15 LUBRIFICATION



ATTENTION!

It is necessary to record the number of hours the motor is running in order to determine when bearing relubrication is required. If the motor is not running continuously, the date of installation must be recorded, since relubrication is recommended every six months, even when the motor was never run during this time.



ATTENTION!

Beware of all rotation parts!
Grease can cause skin and eye irritation. Follow all safety precautions specified by the grease manufacturer.

15.1 SHIELDD/SEALED BEARINGS

Motors fitted with ZZ/2Z, greased for life, the bearings must be replaced according to the running hours informed at the respective motor datasheet. Motors fitted with open bearings must respect the lubrication interval as indicated in the data sheet. Check motor nameplate for determining the used bearing type.

15.2 MACHINES FITTED WITH GREASE NIPPLES

Grease nipples are usually used in motors frame above and included 160 for SMOKE Motors up to F300 temperature class and above and included 225 for F400 temperature class.

Maintenance includes:

- a) Attention to the overall bearing status.
- b) Cleaning and lubrication.
- c) Detailed inspection of the bearings.

The motor noise should be checked at regular intervals as recommended before. A well-tuned ear is perfectly capable of distinguishing unusual noises, even with rudimentary tools (such as a screwdriver, etc). For more reliable and preventive bearing analysis, sophisticated equipment is required.

Bearings should be lubricated to avoid metallic contact of the moving parts, and also for protection against corrosion and wear. Lubricant properties deteriorate in the course of time and due to mechanical operation and, furthermore, all lubricants are subject to contamination under working conditions. For this reason, lubricants must be renewed or replenished from time to time.

15.3 LUBRIFICATIONS INTERVALS



NOTE!

Bearings with grease nipples facilities must be replaced after 40,000 running hours.



ATTENTION!

If Krytox GPL226 is the grease, it may cause higher noise levels particularly at low temperatures, or when intermittent duty does not allow a running temperature above 20 °C in the bearing. Please contact WEG if the service temperature is below -5 °C.

Type of grease, lubrication intervals, amount of grease and type of bearing and clearance are indicated on the motor nameplate. Lubrication intervals depend on motor size, speed, working conditions, type of grease used and ambient temperature.

**NOTE!**

Bearings with grease nipples facilities must be replaced after 40,000 running hours.

15.4 QUALITY AND AMOUNT OF GREASE

Correct lubrication is important for proper bearing operation, i. e., the grease must be applied correctly and in sufficient amount. On the other hand, insufficient or excessive greasing may cause bearing damage.

**ATTENTION!**

SHUTDOWN PROCEDURE - Before proceeding any task, switch-off the motor, since there are moving part and hot surfaces that may cause serious injurious.

Excessive greasing causes overheating due to high resistance caused by the rotating parts and, in particular, by the lubricant compacting and its eventual lubricating characteristic losses. Excess of grease may cause leakage and motor winding contamination. Lack of greasing causes overheating due to high friction between the rolling elements and the outer ring and inner race.

15.5 GREASE COMPATIBILITY

Incompatibility between different grease types can cause problems.

**ATTENTION!**

Motors that are used in an equipment certified under the standard EN 12101-3 shall not have their grease changed or mixed. Grease modification is considered a critical change of the equipment and may invalidate the certification.

Regrease bearings with the grease indicated on the motor nameplate only.

**ATTENTION!**

Never mix greases of different bases.

Example: lithium-based grease should never be mixed with sodium or calcium-based grease.

15.6 DRIVE END AND NON-DRIVE END BEARING RELUBRICATION STEPS

1. Before lubricating the bearing, clean the area around the grease nipples with a clean cotton cloth.
2. With the motor running, add with manual grease gun the amount of grease indicated on the bearing nameplate.
3. Leave the motor running enough time to spread the grease on the bearing.
4. Check bearing temperature to make sure there have not been significant variations.

**NOTE!**

During the first start or after a bearing relubrication it may appear a temporary temperature rise, approx. during 10-20 hours.

If the motor cannot be lubricated while it is running, lubrication can be carried out while the machine is at a standstill, proceeding as below:

1. Inject about half amount of required grease, and run the motor at full speed for a few minutes.
2. Switch off the motor and inject the remaining grease.

3. Start the motor again to spread the grease internally.

Be careful with the numbers of motor starts.



ATTENTION!

The bearing life is estimated through L10. Beyond the periodical maintenance, we recommend checking the conditions of the bearings (using special equipment) at least at each lubrication. Depending on the results, the bearing must be replaced by a new one.



ATTENTION!

The lubrication intervals are based on bearing operating temperature of 75 °C (frame 63 to 200) and 85 °C (frame 225 to 500). Some designs may present different references. An increasing of the ambient temperature raises the bearing temperature correspondingly. For each 15 °C of temperature rise, the relubrication should be reduced by half.



ATTENTION!

Motors mounted inside of fan ducts and with grease nipples must have external greasing nipples mounted on the external of the fan duct with a nameplate affixed advising the type, quantity and relubrication interval of the grease.

16 EXTERNAL/INTERNAL MAINTENANCE

**ATTENTION!**

TRANSPORTATION CARE: Motors fitted with a roller or angular contact bearings must have their shaft locked during the transport in order to avoid bearing damage. For locking the shaft, use the shaft locking device shipped with the motor.

**ATTENTION!**

SMOKE EXTRACTION motors must NOT be re-wound. They are specially designed and requires special procedures. In case of doubts, please contact WEG Service Center.

16.1 CLEANLINESS

Motor

Motors should be kept clean, free of dust, dirt, and oil. Soft brushes or clean cotton rags should be used to clean the motors. Compressed air should be used to remove non-abrasive dust from the fan cover, fan and cooling fins.

Oil or damp impregnated impurities can be removed with rags soaked in a suitable solvent. Terminal boxes should also be cleaned; the terminals should be free of oxidation, in perfect mechanical condition, and all unused space must be dust free.

16.2 PARTIAL MAINTENANCE

- Drain the condensed water.
- If necessary, clean the inside of the terminal boxes.
- Inspect winding insulation visually.
- Verify if the all screws are well tightened.

So the complete maintenance (dismantling, winding drying, bearing replacement, assembly, etc...) can be carried out only by WEG Authorized Repair Shops.

16.3 SPARE PARTS

How to order:

When ordering spare parts, motor type and serial number must be always given as indicated on the nameplate. Consult our repair shop or branch nearest you in case of doubts.

Keeping stock:

It is recommended to keep in stock the spare parts that, under normal use, can have some kind of wear such as:

- An set of bearings.
- Set of seals.

17 ABNORMAL SITUATIONS DURING OPERATION

The most common abnormal operating conditions that affect the motor running during operation can be avoided by predictive maintenance.

Sufficient ventilation, cleanliness and careful maintenance are the main factors. The further essential factor is the prompt attention given to all abnormal situation such as vibrations, shaft knocks, insulation resistance decrease, smoke or fire, sudden changes of bearing temperature increase.

When failures of electric or mechanical nature arise, stop the motor immediately and inspect all mechanical and electrical parts of the installation.

In case of fire inside the motor, restrain and suffocate it by closing the ventilation openings. For extinguishing the fire, use dry chemical or CO₂ extinguishers. Never use water.

17.1 COMMON FAILURES ON SMOKE EXTRACTION MOTORS

Motors built by WEG are normally designed for class H insulation (overtemperature of 105K) and ambient temperatures up to 40 °C (as indicated on the motor nameplate). Most winding failures occur due to overheating (there are a lot of causes to generate overheating, as shown in the previous topic). These failures are identified by the darkening or carbonizing of the wire insulation. This failure can be avoided using the correct protections like temperature sensors on winding and bearings, thermal relay, and others.

Short between turns

A short circuit between turns can occur due to two coincident insulation defects, or as a result of defects arising simultaneously on two adjacent wires. In some cases, the three-phase current unbalance can be so insignificant that the motor protective device fails to act. A short circuit between turns and phases to the ground due to insulation fault is rare, and even so, it normally occurs during the early stages of operation.

Winding failures

a) One winding phase burned.

This fault occurs when the motor is operating in delta connection and the current fails in one power supply cable. Current rises 2 to 2.5 times in the remaining winding with a simultaneous drop of motor speed. If the motor stops, the current will increase 3.5 to 4 times relating to its rated value. In most cases, this fault is due to lack of a protection switch, or due to the fact that this switch has been set too high.

b) Two winding phases burned.

This failure occurs when the current fails in one power supply cable and the motor winding is star connected. One of the winding phases remains current less while the other absorbs the voltage and carries an excessive current. The slip almost doubles.

c) Three winding phases burned.

Probable cause 1:

- Motor protected by fuses only. An overload on the motor will be the cause of the trouble. As a consequence, progressive carbonizing of the wires and insulation will generate a short-circuit between turns, or a short-circuit against the frame. A protection switch installed before the motor can easily solve this problem.

Probable cause 2:

- Motor is not connected correctly.

- For example: a motor with windings designed for 220/380 V is connected through 380 V. The drawn current will be so high that the winding will burn out in few seconds if the fuses or the protection switch set incorrectly fails to react promptly.

ABNORMAL SITUATIONS DURING OPERATION

Probable cause 3:

- The start delta switch is not commutated and the motor runs under overload conditions at star connection during a certain period. As it only develops 1/3 of its torque, the motor cannot reach the rated speed. The increase of slip results in higher ohmic losses arising from the Joule effect. As the stator current, consistent with the load, may not exceed the rated value for delta connection, the protection switch will not act. Due to the increased winding and motor losses, the motor will overheat and the winding will burn out.

Probable cause 4:

- These failures are caused by thermal overload, due to excessive starts under intermittent operation or due to long starting cycle.
- The perfect motors operation under these conditions is only ensured when the following values are taken into account (these must be informed during the design stage).

- a) The number of starts per hour.
- b) Starting with or without load.
- c) Mechanical brake or current inversion.
- d) Acceleration of load connected to the motor shaft.
- e) Load torque related to speed during acceleration and braking.
- f) Correct ambient temperature and altitude.

Rotor Failures

Motor running under load conditions generates noises of several intensities, decreasing the frequency while the load is increased. The reason for this will be, in most cases, an unsymmetrical rotor winding. In squirrel cage motors, this will cause nearly always the break of one or more rotor bars; simultaneously, periodical stator current fluctuations may be recorded. Failures due to spot heating in one or more rotor bars can be identified by the blue coloration at the affected spots. If there are failures in various adjacent bars, vibrations and lack of power can occur. When rotor core shows a blue or violet coloration, this will be a sign of overloading/overheating.

This can be caused by an overly high slip, by too many starts or overlong starting cycles. This failure can also be caused due to a insufficient power supply voltage.

Bearing failures

Bearing failure are the most frequent causes of delayed breakdowns. The most common reasons for this failure are identified as excessive vibration, incorrect operation, bad alignment, unbalanced couplings, and excessive radial and/or axial loads and not followed lubrication procedures as indicated on the nameplate.

Shaft breaking Although bearings generally constitute the weakest part of the motor, and the shafts are designed with a wide margin of safety, notwithstanding shaft may break due to fatigue from bending stress caused, for instance, by excessive belt tension. In most cases, shaft breakings occur right behind the drive end bearing. As a consequence of alternating bending stresses, induced by a rotating shaft, breakings travel inwards from the outside of the shaft until the rupture point is reached when the remaining shaft cross-section resistance no more withstand to the stressed.

Thus avoid additional drilling on shaft (fastening screw holes) since such machining operations tend to cause stress concentrations. The replacement of only one or two belts of a belt drive system may cause frequently shaft breaking, besides being an incorrect practice. Used and consequently stretched belts on a belt drive system, especially when mounted inner side of the pulley, while new and unscratched belts are mounted outer side on the same pulley and so farther from the bearing, can cause shaft stress. Damage arising from poorly fitted transmission parts or improper motor alignment. Bearing damage and shaft breaking are often caused by the unsuitable fitting of pulley, couplings or pinions on the shaft.

18 TROUBLESHOOTING CHART X SOLUTIONS



NOTE!

This troubleshooting chart provides a basic list of problems that may occur during motor operation, possible causes and recommended corrective actions. In case of doubts, please contact WEG Service Center. In certain cases, the bearing manufacturer must be contacted to find out the cause of the failure.

Problem	Possible Cause	Corrective Action
Motor does not start, neither coupled nor decoupled	Power cables are interrupted	Check the control panel and the motor power supply cables
	Blown fuses	Replace blown fuses
	Wrong motor connection	Correct the motor connection according to connection diagram
	Locked rotor	Check motor shaft to ensure that it rotates freely
The motor starts at no-load, but fails when load is applied. It starts very slowly and does not reach the rated speed	Load torque is too high during start-up	Do not start the motor on load
	Too high voltage drop in the power cables	Check the installation dimensioning (transformer, cable cross section, relays, circuit breakers, etc.)
Abnormal/excessive noise	Defective transmission component or defective driven machine	Check the transmission force, the coupling and the alignment
	Misaligned / unlevelled base	Align / level the motor with the driven machine
	Unbalanced components or unbalanced driven machine	Balance the machine set again
	Different balancing methods used for motor and coupling balancing (half key, full key)	Balance the motor again
	Wrong motor direction of rotation	Reverse the direction of rotation
	Loose bolts	Tighten the bolts
	Foundation resonance	Check the foundation design
Motor overheating	Insufficient cooling	Clean air inlet and outlet and cooling fins
		Check the minimum required distance between the fan cover and nearest walls. See Chapter 7 INSTALLATION on the page 7-1
		Check air temperature at inlet
	Overload	Measure motor current, evaluate motor application and if required, reduce the load
	Number of starts per hour is too high or the load inertia moment is too high	Reduce the number of starts per hour
	Power supply voltage too high	Check the motor power supply voltage. Power supply voltage must not exceed the tolerance specified in item 7.2
	Power supply voltage too low	Check the motor power supply voltage and the voltage drop. Power supply voltage must not exceed the tolerance specified in item 7.2
	Interrupted power supply	Check the connection of the power cables
	Voltage unbalance at the motor terminals	Check for blown fuses, wrong commands, voltage unbalance in the power line, phase fault or interrupted power cables
	Direction of rotation is not compatible with the unidirectional fan	Check if the direction of rotation matches the rotation arrow indicated on end shield
Bearing overheating	Excessive grease/oil	Clean the bearing and lubricate it according to the provided recommendations
	Grease/oil aging	
	The used grease/oil does not match the specified one	
	Lack of grease/oil	Lubricate the bearing according to the provided 4 recommendations
	Excessive axial or radial forces due to the belt tension	Reduce the belt tension Reduce the load applied to the motor

Manufacturers:

WEG Equipamentos Elétricos S.A.
Av. Prefeito Waldemar Grubba, 3000
89256-900 - Jaraguá do Sul - SC - Brazil
www.weg.net

WEG Linhares Equipamentos Elétricos S.A.
Rod. BR 101, Km 161,5, s/n.
Distrito Industrial Rio Quartel, Bairro Rio Quartel de Baixo
29915-500 - Linhares - ES - Brazil
www.weg.net

WEG MEXICO, S.A. DE C.V.
Carretera Jorobas - Tula Km 3.5, Manzana 5,
Lote 1, Fraccionamiento Parque Industrial Huehuetoca,
Municipio de Huehuetoca, C.P. 54680,
CD. de Mexico y Área Metropolitana - Mexico
www.weg.net/mx

WEG (Jiangsu) Electric Equipment CO., LTD.
No. 88, Huimin West Road, Chengbei Street, Rugao City,
Jiangsu Province - China
www.weg.net/cn

WEG (Nantong) Electric Motor Manufacturing CO., LTD.
No. 128# - Xinkai South Road, Nantong
Economic & Technical Development
Zone, Nantong, Jiangsu Province - China
www.weg.net/cn

ZEST WEG Electric
6 Laneshaw Street, Longlake Extension 4,
Johannesburg, Gauteng, 1619 - South Africa
www.weg.net/za

WEG UK Contact:
Single Contact Point in the United Kingdom for compiling
the technical documentation: Gustavo da Silva
Authorised Representative

WEGeuro, S.A.
Rua António Joaquim Campos Monteiro, 510,
Santa Cristina do Couto, 4780-165 - Santo Tirso - Portugal
Single Contact Point in the European Union for compiling
the technical documentation:
Luís Filipe Oliveira Silva Castro Araújo
Authorised Representative
www.weg.net/pt

**VOLT ELEKTRİK MOTOR SANAYİ VE TİCARET ANONİM
ŞİRKETİ**
Kazım Karabekir Cad. No:84 Kemalpaşa 35735 İzmir /
Türkiye
<https://voltmotor.com.tr/>

WEG INDUSTRIES (INDIA) PVT.LTD.
No. E20 (North) SIPCOT Industrial Complex - Phase II -
Expansion II. Mornapalli Village Hosur 635109 Tamil Nadu

Changzhou Yatong Jiewei Electromotor Co.,LTD
No.118, Dongdu West Road, Luoyang Town, Wujin,
Changzhou, Jiangsu, China.

Antriebstechnik KATT Hessen GmbH
(Bahnhofstrasse 66, 34576 Homberg (Efze), Germany
<https://akh-antriebstechnik.de/>

WEG (Chang Zhou) Automation Equipment Co.,Ltd
No. 227, Xincheng Avenue, Jintan District,
Changzhou City, Jiangsu Province, China.
www.weg.net/cn

Marathon Electric Motors India Ltd.
1 Taratala Road, Kolkata, West Bengal, India
Postal Code: 700024
<https://www.marathonelectric.in/>

Marathon Electric Motors India Ltd.
B-1, Gallops Industrial Park, Changodar Ahmedabad,
Gujarat- 382213, India
Postal Code: 382220
<https://www.marathonelectric.in/>

Cemp srl
Via Piemonte, 16 - 120030, Senago, Milano, Italy
<http://www.cemp.eu>

**MARATHON ELECTRIC MANUFACTURING OF
MEXICO S. DE R.L. DE C.V.**
Calle de la Industria #2013 Parque Industrial Millenium,
Santa Catarina, Nuevo León, 66367, Mexico
<https://www.marathonelectric.com/>

Marathon Electric (Wuxi) Co., Ltd.
No. 6 Xiangge Road, Hudai Town,
Wuxi, Jiangsu Province, China
<https://www.marathonelectric.com/>

Marathon Electric LLC
100 East Randolph St., Wausau, WI 54401, United States
<https://www.marathonelectric.com/>

Declares under sole responsibility that WEG electric motors and components used for following motor lines:

BLDC, W01, W11, W12, W20, W21, W22, W23, W30, W40, W50, W51, W60, W80, WFL, WIN, K1F, K1N, K1O, K1S, K1T, K1W, K2F, K2N, K2U, General Purpose, HGF, Roller Table, Steel Motor, PSC, Pump/Filter, Servomotor, TerraMax, Vertical High Thrust, Water Cooled and Wquattro

When installed, maintained, and used in applications for which they were designed, and in compliance with the relevant installation standards and manufacturer's instructions, comply with the provisions of the following relevant European Union harmonization legislation and standards, wherever applicable:

Electrical Equipment (Safety) Regulations	S.I. 2016/1101*.
The Ecodesign for Energy-Related Products Regulations and Energy Information	S.I. 2021/745*.
The Restriction of the Use of Certain Hazardous Substances in Electrical and Electronic Equipment Regulations	S.I. 2012/3032*.
Supply of Machinery (Safety) Regulations	S.I. 2008/1597 amended by S.I.2011/2157**.
Electromagnetic Compatibility Regulations	S.I.2016/1091 (electric motors are considered inherently benign in terms of electromagnetic compatibility).

EN 60034-1:2010 + AC:2010 / EN IEC 60034-2-1:2024 / EN IEC 60034-5:2020 / EN 60034-6:1993 / EN 60034-7:1993 + A1:2001 / EN 60034-8:2007 + A1:2014 / EN 60034-9:2005 + A1:2007 / EN 60034-11:2004 / EN IEC 60034-12:2024 / EN IEC 60034-14:2018 / EN 60034-30-1:2014 / EN 60204-1:2018 / EN IEC 60204-11:2019 / EN IEC 63000:2023 / CLC IEC/TS 60034-30-2:2021 and CLC IEC/TS 60034-25:2024.

* Electric motors with a voltage rating higher than 1000V are not under the scope.

** Electric motors are considered partly completed machinery and are supplied with a "Declaration of Incorporation".

Declaration of Incorporation

The products above cannot be put into service until the machinery into which they have been incorporated has been declared in conformity with the Machinery Directive.

A Technical Documentation for the products above is compiled in accordance with Part 7 (b) of schedule 2 of The Supply of Machinery (Safety) Regulations 2008.

We undertake to transmit, in response to a reasoned request by the national authorities, relevant information on the product identified above (partly completed machinery) through WEG authorized representative established in the United Kingdom. The method of transmission shall be electronic or physical method and shall be without prejudice to the intellectual property rights of the manufacturer.

Signed for and on behalf of the manufacturer:

VITOR
MARCON:795681739
00

Vitor Marcon
Quality Systems and
Certifications Manager
Jaraguá do Sul
January 22, 2026

SILVIO AUGUSTO
BILLO:82118078900

Silvio Augusto Billo
Engineering Director
Jaraguá do Sul
January 22, 2026

EU DECLARATION OF CONFORMITY



Manufacturers:

WEG Equipamentos Elétricos S.A.

Av. Prefeito Waldemar Grubba, 3000
89256-900 - Jaraguá do Sul - SC - Brazil
www.weg.net

WEG Linhares Equipamentos Elétricos S.A.

Rod. BR 101, Km 161,5, s/n.
Distrito Industrial Rio Quartel. Bairro Rio Quartel de Baixo
29915-500 - Linhares - ES - Brazil
www.weg.net

WEG MEXICO, S.A. DE C.V.

Carretera Jorobas - Tula Km 3.5, Manzana 5,
Lote 1, Fraccionamiento Parque Industrial Huehuetoca,
Municipio de Huehuetoca, C.P. 54680,
CD. de Mexico y Área Metropolitana - Mexico
www.weg.net/mx

WEG (Jiangsu) Electric Equipment CO., LTD.

No. 88, Huimin West Road, Chengbei Street, Rugao City,
Jiangsu Province - China
www.weg.net/cn

WEG (Nantong) Electric Motor Manufacturing CO., LTD.

No. 128# - Xinkai South Road, Nantong
Economic & Technical Development
Zone, Nantong, Jiangsu Province - China
www.weg.net/cn

ZEST WEG Electric

6 Laneshaw Street, Longlake Extension 4,
Johannesburg, Gauteng, 1619 - South Africa
www.weg.net/za

WEGeuro, S.A.

Rua António Joaquim Campos Monteiro, 510,
Santa Cristina do Couto, 4780-165 - Santo Tirso - Portugal
Single Contact Point in the European Union for compiling
the technical documentation:
Luís Filipe Oliveira Silva Castro Araújo
Authorised Representative
www.weg.net/pt

VOLT ELEKTRİK MOTOR SANAYİ VE TİCARET ANONİM

ŞİRKETİ

Kazım Karabekir Cad. No:84 Kemalpaşa 35735 İzmir /
Türkiye
<https://voltmotor.com.tr/>

WEG INDUSTRIES (INDIA) PVT.LTD.

No. E20 (North) SIPCOT Industrial Complex - Phase II -
Expansion II. Mornapalli Village Hosur 635109 Tamil Nadu

Changzhou Yatong Jiewei Electromotor Co.,LTD

No.118, Dongdu West Road, Luoyang Town, Wujin,
Changzhou, Jiangsu, China.

Antriebstechnik KATT Hessen GmbH

(Bahnhofstrasse 66, 34576 Homburg (Efze), Germany
<https://akh-antriebstechnik.de/>

WEG (Chang Zhou) Automation Equipment Co.,Ltd

No. 227, Xincheng Avenue, Jintan District,
Changzhou City, Jiangsu Province, China.
www.weg.net/cn

Marathon Electric Motors India Ltd.

1 Taratala Road, Kolkata, West Bengal, India
Postal Code: 700024
<https://www.marathonelectric.in/>

Marathon Electric Motors India Ltd.

B-1, Gallops Industrial Park, Changodar Ahmedabad,
Gujarat- 382213, India
Postal Code: 382220
<https://www.marathonelectric.in/>

Cemp srl

Via Piemonte, 16 - 120030, Senago, Milano, Italy
<http://www.cemp.eu>

MARATHON ELECTRIC MANUFACTURING OF

MEXICO S. DE R.L. DE C.V

Calle de la Industria #2013 Parque Industrial Millenium,
Santa Catarina, Nuevo León, 66367, Mexico
<https://www.marathonelectric.com/>

Marathon Electric (Wuxi) Co., Ltd.

No. 6 Xiangge Road, Hudai Town,
Wuxi, Jiangsu Province, China
<https://www.marathonelectric.com/>

Marathon Electric LLC

100 East Randolph St., Wausau, WI 54401, United States
<https://www.marathonelectric.com/>

Declares under sole responsibility that WEG electric motors and components used for following motor lines:

BLDC, W01, W11, W12, W20, W21, W22, W23, W30, W40, W50, W51, W60, W80, WFL, WIN, K1F, K1N, K1O, K1S, K1T, K1W, K2F, K2N, K2U, General Purpose, HGF, Roller Table, Steel Motor, PSC, Pump/Filter, Servomotor, TerraMax, Vertical High Thrust, Water Cooled and WQuattro

when installed, maintained and used in applications for which they were designed, and in compliance with the relevant installation standards and manufacturer's instructions, comply with the provisions of the following relevant European Union harmonization legislation and standards, wherever applicable:

Low Voltage Directive	2014/35/EU*.
EU Ecodesign Directive	(EU)2019/1781* as amended by Commission Regulation (EU)2021/341; Directive 2009/125/EC*.
RoHS Directive	2011/65/EU* and its amendments (including Directive 2015/863/EU).
Machinery Directive	2006/42/EC**.
EMC Directive	2014/30/EU (electric motors are considered inherently benign in terms of electromagnetic compatibility).

The fulfilment of the safety objectives of the relevant European Union harmonization legislation has been demonstrated by compliance with the following standards, wherever applicable:

EN 60034-1:2010 + AC:2010 / EN IEC 60034-2-1:2024 / EN IEC 60034-5:2020 / EN 60034-6:1993 / EN 60034-7:1993 + A1:2001 / EN 60034-8:2007 + A1:2014 / EN 60034-9:2005 + A1:2007 / EN 60034-11:2004 / EN IEC 60034-12:2024 / EN IEC 60034-14:2018 / EN 60034-30-1:2014 / EN 60204-1:2018 / EN IEC 60204-11:2019 / CLC IEC/TS 60034-30-2:2021 / EN 61800-5-1: 2007+A1:2017+A11:2021 / EN IEC 61800-3: 2023 / EN IEC 63000:2018 / CLC IEC/TS 60034-25:2024 and IEC 60034-30-3:2024.

* Electric motors with a voltage rating higher than 1000V are not under the scope.

** Electric motors are considered partly completed machinery and are supplied with a "Declaration of Incorporation".

Declaration of Incorporation

The products above cannot be put into service until the machinery into which they have been incorporated has been declared in conformity with the Machinery Directive.

A Technical Documentation for the products above is compiled in accordance with part B of annex VII of Machinery Directive 2006/42/EC.

We undertake to transmit, in response to a reasoned request by the national authorities, relevant information on the product identified above (partly completed machinery) through WEG authorized representative established in the European Union. The method of transmission shall be electronic or physical method and shall be without prejudice to the intellectual property rights of the manufacturer.

Signed for and on behalf of the manufacturer:

VITOR
MARCON:795681739
00

Assinado de forma digital por
VITOR MARCON:79568173900
Dados: 2026.01.28 14:05:56
-03'00'

Vitor Marcon
Quality Systems and
Certifications Manager
Jaraguá do Sul
January 22, 2026

SILVIO AUGUSTO
BILLO:82118078900

Assinado de forma digital por
SILVIO AUGUSTO
BILLO:82118078900
Dados: 2026.01.29 13:06:17 -03'00'

Silvio Augusto Billo
Engineering Director
Jaraguá do Sul
January 22, 2026

DEC19725



BRAZIL

WEG MOTORES LTDA

Av. Prefeito Waldemar Grubba, 3000

89256-900 - Jaraguá do Sul - SC

Phone: 55 (47) 3276-4000

E-mail: motores@weg.net

www.weg.net