

Driving efficiency and sustainability

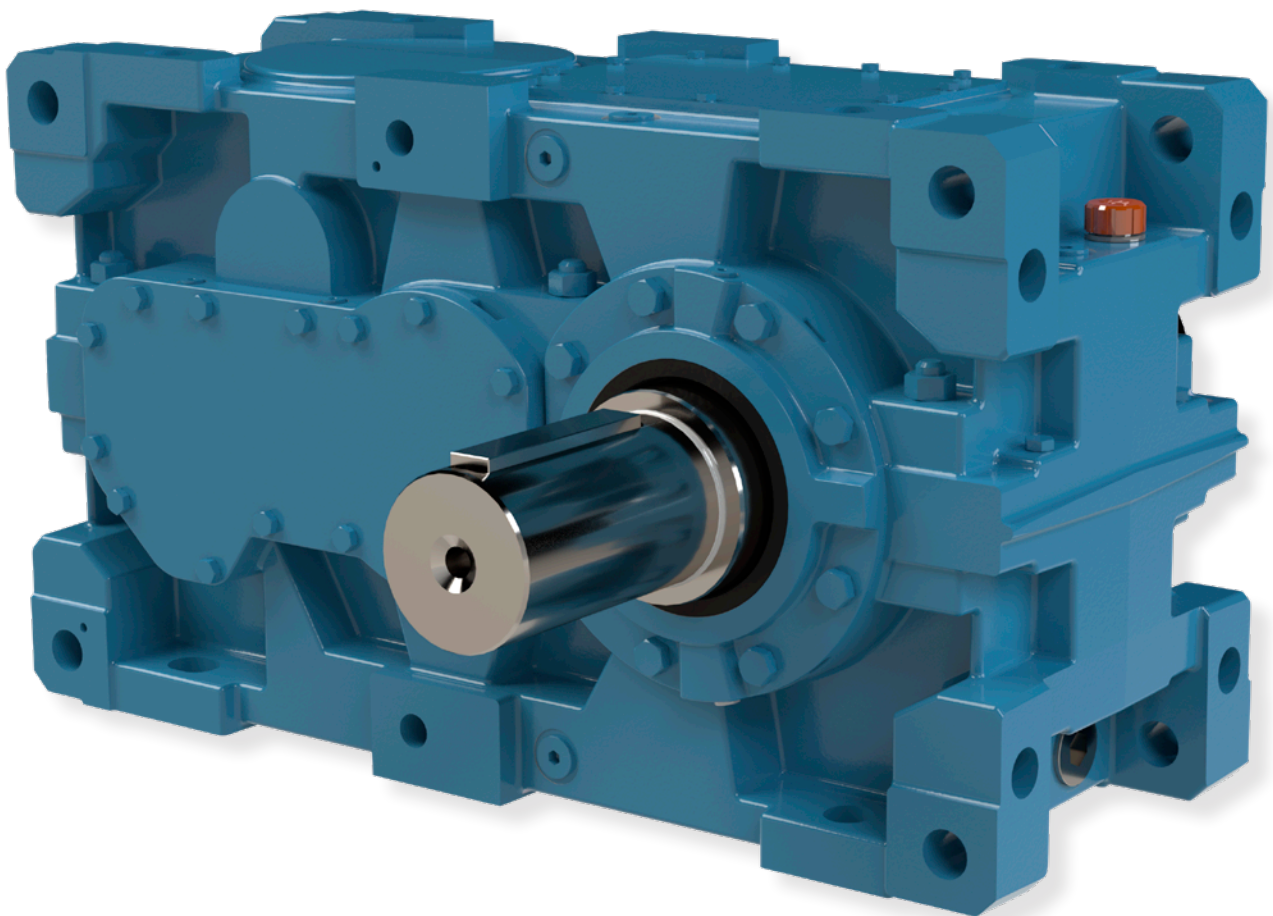

WG50

Instructions manual



General Considerations

The purpose of this manual is to provide important information that must be observed during the transport, storage, installation, operation and maintenance of the WEG products (gearboxes, geared motors, parts and pieces) and, for this reason, we recommend reading carefully the instructions contained herein. Failure to observe the instructions indicated in this manual, in the engine manual (if provided), voids the product warranty and may result in serious personal and property damage.

In the case of a geared motor supplied with a WEG motor, the Motor Installation, Operation and Maintenance Manual is available on the website: www.weg.net in the “downloads” section. This manual must be carefully observed.

Índice

1. Safety notes and information	4
1.1. General information.....	4
1.2. Exclusion of liability.....	4
1.3. Copyright and protection rights.....	4
1.4. Warranty term.....	4
2. General safety	6
3. Transport	6
4. Storage	7
4.1. Non-operating period.....	7
4.2. Long Term Storage.....	7
4.3. Operation after Storage.....	8
4.4. Lubricants.....	8
5. Gearbox Description	15
5.1. Gearbox nameplate.....	15
6. Installation	15
7. Operation	20
8. Maintenance	20
8.1. Disassembly and assembly of gears and bearings.....	21
9. Repairs	23
10. Environmental Guidelines	23

1. Safety notes and information

All safety and warning instructions must be followed without exception!

**WARNING!**

Electrical or mechanical hazard warning.

**ATTENTION!**

Important instructions for safe and trouble-free operation.

1.1. General information

This documentation is an integral part of the product and must be read carefully before the product is put into operation. The information is intended for all persons in charge of the assembly, installation, commissioning and maintenance of the product and must be followed, we recommend keeping it close to the product.

We assume no responsibility for damages or interruptions of operations resulting from non-compliance with this documentation.

In the interest of carrying out future developments, we reserve all rights to make modifications and adjustments to this documentation without prior notice.

In case of doubts or if you want other information, consult WEG.

Planned use:

The Gearboxes and Geared motors are exclusively intended for the generation of a defined rotary movement in machines and equipment.

Any use other than this is considered an unplanned use.

The user / operator of the machine or equipment is solely responsible for the damages resulting from this.

The details of this manual, the nameplate, as well as other technical documentation, must be considered and observed.

1.2. Exclusion of liability

The information contained in this Instruction Manual must be followed to ensure the safe and fault-free operation of the Gearboxes or Geared Motors and to achieve the specified product characteristics and performance requirements.

WEG assumes no liability for damage to persons, equipment or property resulting from non-compliance with this instruction manual. In these cases, any liability for defects is excluded.

1.3. Copyright and protection rights

All technical documents are protected in accordance with copyright law. The processing, reproduction and disclosure of them, even if in parts, as well as other use is not allowed, except with express written concession.

1.4. Warranty term

The warranty against manufacturing and material defects offered by WEG is:

- **Products:** standard term of 12 months from the date of issuance of the Invoice.
- **Services:** standard term of 6 months from the date of issuance of the Invoice.

NOTES:

1) *When the warranty period is expired, but within the current month, the service will be made as a guarantee (eg: warranty expiration: 04/01/2017 + service: 04/21/2017 = warranty accepted)*

2) *If a differentiated warranty period is defined in the technical-commercial proposal for a given supply, it will prevail over the above period;*

3) *The deadlines established above are independent of the date of installation of the product and its entry into operation.*

WEG products that present defects arising from failures of: sizing and specification (when carried out by WEG), design, material and manufacture are eligible for warranty, provided that the technical analysis carried out by WEG has revealed the existence of items with defects that can be classified in these terms and within the warranty period above.

In the event of a deviation from the normal operation of the product, the customer must immediately notify WEG of the defects occurred and make the product available to WEG or its Authorized Technical Assurances for the period necessary to identify the cause of the deviation, verification of the warranty coverage, and the due repair must be performed only after the analysis of the RNC (Non-Compliance Report).

WEG reserves the right to test the products returned under warranty to verify the defect/manufacturing defect, as well as disassemble the products to verify the real cause of the failure presented.

To be entitled to warranty, the customer must meet the specifications of the technical documents of WEG, especially those provided for in the Installation, Operation and Maintenance Manual of the products. The warranty conditions offered by WEG will always be respected, respecting all the precepts of the civil law that governs the commercial relationship.

The warranty will not be granted for the following cases:

- If the customer or end user opens, performs repairs and/or modifies the gearbox or geared motor without prior authorization from WEG;
- Oil leakage by the retainers due to drying caused by paints or paints made by the end customer or suppliers of machinery and equipment;
- Incorrect installation of the equipment (working position different from that requested, out of alignment, unstable base, shocks or strikes on the axles, etc.), in total disregard of the instructions made in the respective items of the Installation, Operation and Maintenance Manual of the products;
- Inadequate, inefficient or non-existent lubrication, in cases that are provided without lubricant;
- Lack of preventive maintenance, according to the Installation, Operation and Maintenance Manual of the products;
- Incorrect specification or poor sizing of the equipment, when made by the customer;
- Shocks or fall in the transport of responsibility of the client or third parties contracted by the same;
- Oil leak caused by obstructed vent;
- Contamination of the oil by external agents (dust, water, etc.), when the gearbox has not been requested with an air filter;
- Wrong connection or failures in the power supply network, in the case of motors;
- Repair and/or adjustment performed by an unqualified/authorized person;
- Negligence, recklessness or malpractice in the installation and operation of the products;
- Natural wear of the product due to the use and/or wear of the product due to the action of agents of nature (such as time actions, corrosion, etc.);
- Gear boxes /Geared motors without identification plates;
- Absence or tampering with the serial number.

The warranty does not cover expenses arising from the uninstallation and/or disassembly or installation and/or assembly of the product at the customer's premises.

The warranty does not cover damage caused by third party manufacturing and/or marketing equipment coupled to the products supplied by WEG. It also does not cover defects and/or problems arising from force majeure or other causes that cannot be attributed to WEG, such as, but not limited to: incorrect or incomplete specifications or data by the customer, transportation, storage, handling, installation, operation and maintenance in disagreement with the instructions provided, accidents, civil works deficiencies, use in applications and/or environments for which the product was not designed and/or sized, equipment and/or components not included in the scope of supply of WEG.

Warranty services may be provided at the WEG factory and/or by the Technical Assurances Authorized by WEG. Under no circumstances will these warranty services extend the warranty periods of the equipment. Exceptions to this rule are warranty cases where it is necessary to change the project to suit the customer's application.

The civil liability of WEG is limited to the product supplied, not being responsible for indirect or consequential damages, such as loss of profits, loss of revenue and the like, resulting from the impossibility of using the product while it is damaged and/or submitted to the warranty process.

2. General safety

The customer is responsible for installing the unit in accordance with good engineering practices.

The instructions contained in this Instruction Manual must be followed to achieve the characteristics of the drive units and to ensure approval in the case of warranty requests.

Make sure you never put damaged products into operation!

Read this Instruction Manual carefully before beginning any adjustment, installation or maintenance.

The installation, commissioning, maintenance and repair of the geared motor as well as the electrical accessory equipment can only be performed by qualified technical personnel, considering the following items:

- Operating Instructions
- Information labels on geared motor
- All other project documents, installation manuals and operation manuals
- Geared motor specifications and requirements pertaining to geared motor
- The applicable regional and national regulations in safety and accident prevention.

WARNING!



Work is only allowed:

- With the drive stopped,
- When disconnected and prevented from being turned on again.

The protection around rotating parts must be observed in the installation project of the equipment to be activated, aiming at protecting people and preventing accidents.

Operation of the drive unit by means of a frequency inverter can only take place if the specifications shown on the motor nameplate are met.

3. Transport

Upon delivery, inspect the material to verify possible damages occurred during transport. In case of damage immediately inform the carrier and/or the WEG, it may be necessary to avoid putting into operation.

If necessary use appropriate transport equipment. Before putting into operation remove all fastening devices used during transport.

ATTENTION!



The lifting holes are designed only for the weight of the gear box / geared motor, no additional load should be placed.

When moving gearboxes, use rope, cables, straps and suitable suspension equipment so as not to endanger human lives and the equipment itself.

The gearboxes must be moved using the suspension screw/shackles and in the absence of it, the unit must be suspended through the gearbox housing (Figure 1), when there is a motor to be moved together with the motor eyelet (respecting the maximum angle of 60° between the cables). (Never suspend the equipment only through the motor).

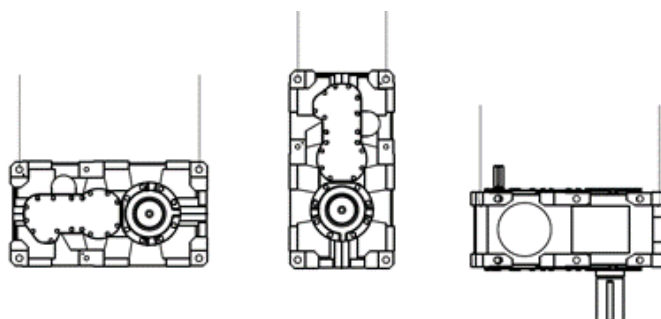

Figure 1 - Movimiento de los reductores

Before fully lifting the gearbox/geared motor, make sure the load is properly balanced. All handling of the gearbox/geared motor must be carried out in a gentle manner to avoid impacts and damage to the gearbox/geared motor, especially at the tips of the axles.

4. Storage

WEG products (gearboxes, geared motors, parts and pieces) must be stored in their original packaging indoors (not directly exposed to sunlight or UV rays), dry, protected against insects, free of dust, air humidity less than 60%, free of gases, fungi, corrosive agents (contaminated air, ozone, gases, solvents, acids, alkali, salts, radioactivity, etc.) and ambient temperature between -5°C to $+40^{\circ}\text{C}$.

WEG gearboxes/geared motors shall be stored in the specified and provided working position, on a flat surface on pallets or on appropriate shelves (not in direct contact with the floor) and not arranged in a location with shaking and oscillations.

4.1. Non-operating period

The WEG gearboxes/geared motors leave the factory and must be put into operation within a maximum period of 6 months.

For periods of 6 months up to 9 months without operation, it is recommended to fill the entire interior of the gearbox with appropriate lubricants (see item 4.4 Lubricants). Fill the gearbox with oil to the top (just below the vent), thus ensuring that all your gears and bearings are immersed in oil. The input axle of the gearbox must be rotated at least two complete turns and this procedure must be repeated at least once every 2 months.

Notes: Prior to operation, the gearbox/geared motor lubricant must be drained to the appropriate amount for operation.

The appropriate volume of lubricant must be consulted in item 4.4 Lubricants.

Protect the retainers externally with grease and on the gearboxes that have a labyrinth seal ("taconite"), for a period of no operation above 6 months, apply a thin layer of grease on the external surface to prevent dryness. Grease must be removed before the start of operation (recommended grease NLGI#2EP Texaco Multifak EP2 or similar), see item 4.4 Lubricants.

4.2. Long Term Storage

The following are guidelines for cases of storage or shutdown for a long period, that is, more than 9 months without operation. These guidelines are recommended for storage up to a maximum of 2 years. If the relative humidity of the air is less than 50%, the WEG product can be stored for up to 3 years.

Since there may be influences on the gearbox dependent on local conditions, the time indications may vary from those cited above.

If you have any questions, please contact WEG.

Preparation for Storage:

- Remove all moisture from the gearbox and any cooling system of the gearbox;
- Check the oil level and complete if necessary with the lubricant recommended in the product manuals;
- In the gearboxes supplied with lubricating oil, add anti-corrosion agent VCI (Volatile Corrosion Inhibitor) in the lubricant to the extent of 2% of the lubricant capacity. Then rotate the axles several times;
- In cases of gearboxes supplied without oil, mix 10% of the total volume of the lubricant recommended in the manuals with 2% also of this total volume of VCI and place in the gearbox. Reference of VCI additive MV OIL 1061. Mineral Oil already with VCI (Castrol Alpha SP 150 S or Castrol Alpha SP 220 S);
- Seal the gearbox completely by hermetically closing the air holes (vents) and the area around the dipstick with an adhesive tape (if there is dipstick type level);
- Place grease around the shafts close to the retainers; then wrap the shaft areas close to the retainers with an adhesive tape leaving it leaning against the retainers;
- For external fixing surfaces (shafts and flange faces) they are protected from Factory; inspect and protect these surfaces if necessary (in case of loss of the film) with appropriate anticorrosion (Castrol Safecoat DW 801 anti-corrosion protection oil or similar, layer approximately $50\ \mu\text{m}$). Any damage caused by transport in the exterior paint must be corrected;
- If the gearbox is stored outdoors place it on blocks. Make a structure around you (if possible) and cover it with a tarpaulin (cotton tarpaulin). DO NOT use plastic cover. Leave the bottom part open (free) to receive ventilation.

4.3. Operation after Storage

If the storage or shutdown time exceeds 2 years or the ambient temperature deviates from the normal range during storage, it is necessary to replace the gearbox lubricant before start-up.

Considering that they have been properly lubricated, after 2 (two) years, the retainers must be replaced.

- Remove all tape used in preparation for storage;
- Remove all moisture that may have accumulated in the gearbox, clean the gearbox and inspect for any malfunction;
- The anti-corrosion agent VCI is soluble in recommended lubricating oils and does not need to be removed from the gearbox;
- Check this Manual for recommended lubricants and installation, maintenance and operating instructions.

In case the gearbox is fully filled with oil, the amount of oil should be reduced to the recommended amount before start-up. See chapter “Mounting positions and quantities of lubricant”.

If desired, it is possible to supply gearboxes prepared for “long-term storage”. In this case, the WEG must be informed during the quotation and acquisition process. For storage periods above 9 months, gearboxes/geared motors may only come into operation if the above procedures have been complied with.

4.4. Lubricants

Proper lubrication is responsible for the performance and service life of the gearbox. The gearboxes are lubricated by oil bath, and equipped with a dipstick type display (graduated level can be used, see WEG).

The correct oil level is in the center of the serrated mark of the dipstick, with the gearbox stopped and in the required working position.

Before starting the operation, it should be checked that the gearbox is filled with oil and that the lubricant level is adequate as recommended. The lubricant recommended for the industrial line must be extreme pressure mineral oil according to DIN 51517-3 CLP.

The viscosity of the oil depends on the type of gearbox, the angular velocity and the ambient temperature. For gearboxes operating at a rotation on the input shaft, minimum of 500 rpm and maximum of 1800 rpm and minimum ambient temperature of 10 °C and maximum of 40 °C, we recommend oil with viscosity: ISO VG 320. For temperatures outside the minimum range of 10 °C and maximum of 40 °C, consult the WEG.

The operating temperature is the temperature of the lubricating oil after the temperature stabilization period at full load (period after approximately 3 hours of continuous operation). The minimum ambient temperature for the start of operation of the gearboxes depends on the viscosity and the type of lubricating oil. For forced lubrication the minimum permissible ambient temperature is +14 °C with mineral oil and for synthetic Pao oil the minimum ambient temperature is +8 °C.

The external temperature of the housing is approximately 15°C lower than the operating temperature (oil temperature). In case of unfavorable working environment conditions (high humidity, aggressiveness, dust), lubricant change time can be reduced. In this case, the WEG shall be consulted.

In Table 1 we present some types of recommended oil and their respective manufacturers. For different rotations and temperatures, consult WEG.

MANUFACTURER	ISO VG 320 VISCOSITY		
	MINERAL	PAO SYNTHETIC	PG SYNTHETIC
KLUBER	Kluberoil GEM1 -320N	Klubersynth EG4-320	Klubersynth GH6-320
SHELL	OMALA S2 G 320	Omala S4 GX 320	Omala S4 WE 320
FUCHS	GEARMASTER CLP 320	GEARMASTER SYN CLP-HC 320	GEARMASTER PGP CLP-PG 320
MOBIL	MOBILGEAR 600 XP 320	MOBILGEAR SHC 632	-
IPIRANGA	IPIRANGA SP 320	IPIRANGA SP ULTRATECH SINTÉTICO 320	-
CASTROL	Optigear BM 320	Optigear Synthetic X 320	-
PETRONAS	PETRONAS GEAR FL 320	PETRONAS GEAR SYN PAO 320	PETRONAS GEAR SYN PAG 320
WHITMORE	-	DECATHLON F PAO 320	DECATHLON PAG 320
BECHEM	Berugear GS 320 BM CLP	Berusynth GP 320 CLP HC	Berusynth EP 320 CLP PG
PETROBRAS	Lubrax Industrial EGF 320 OS	Lubrax Syntesys Gear PAO 320	-

Table 1 - Aceites recomendados

The quantity of lubricant informed in the following tables, the quantity informed is considered a reference, exact values may vary according to the quantity of gears and their diameters. The exact volume of oil should be obtained after checking the level with the dipstick or sight glass (when available). For oil pressure lubrication, the level must be checked after its operation due to oil retention by the system.

Tables with oil volume:

Legend:

ST: Number of stages

LB1: Oil bath lubrication (Splash)

LP2: Oil pressure lubrication

LI3: Oil immersion lubrication

P = Parallel

R = Orthogonal

T = Upper Orthogonal

WG50	Oil volume table - P1 Mounting Position										
	Oil Volume [L]										
	ST	Lubrication types			ST	Lubrication types			ST	Lubrication types	
2	LB ₁	LP ₂	LI ₃	3	LB ₁	LP ₂	LI ₃	4	LB ₁	LP ₂	LI ₃
W012P	11	11	-	W013P	13	13	-	W014P	-	-	-
W022P	11	11	-	W023P	13	13	-	W024P	-	-	-
W032P	17	17	-	W033P	20	20	-	W034P	20	20	-
W042P	18	18	-	W043P	22	22	-	W044P	21	21	-
W052P	23	23	-	W053P	33	33	-	W054P	32	32	-
W062P	24	24	-	W063P	35	35	-	W064P	34	34	-
W072P	43	43	-	W073P	63	63	-	W074P	61	61	-
W082P	41	41	-	W083P	60	60	-	W084P	58	58	-
W092P	52	52	-	W093P	74	74	-	W094P	72	72	-
W102P	52	52	-	W103P	74	74	-	W104P	72	72	-
W112P	69	69	-	W113P	102	102	-	W114P	98	98	-
W122P	68	68	-	W123P	101	101	-	W124P	97	97	-
W132P	100	100	-	W133P	150	150	-	W134P	145	145	-
W142P	97	97	-	W143P	146	146	-	W144P	140	140	-
W152P	130	130	-	W153P	187	187	-	W154P	180	180	-
W162P	124	124	-	W163P	182	182	-	W164P	175	175	-
ST	Lubrication types			ST	Lubrication types			ST	Lubrication types		
2	LB ₁	LP ₂	LI ₃	3	LB ₁	LP ₂	LI ₃	4	LB ₁	LP ₂	LI ₃
W012R	11	11	-	W013R	12	12	-	W014R	-	-	-
W022R	11	11	-	W023R	13	13	-	W024R	-	-	-
W032R	16	16	-	W033R	20	20	-	W034R	20	20	-
W042R	16	16	-	W043R	22	22	-	W044R	21	21	-
W052R	23	23	-	W053R	33	33	-	W054R	33	33	-
W062R	24	24	-	W063R	35	35	-	W064R	35	35	-
W072R	43	43	-	W073R	62	62	-	W074R	62	62	-
W082R	41	41	-	W083R	59	59	-	W084R	60	60	-
W092R	53	53	-	W093R	74	74	-	W094R	74	74	-
W102R	52	52	-	W103R	73	73	-	W104R	73	73	-
W112R	69	69	-	W113R	102	102	-	W114R	102	102	-
W122R	69	69	-	W123R	101	101	-	W124R	101	101	-
W132R	100	100	-	W133R	150	150	-	W134R	150	150	-
W142R	97	97	-	W143R	145	145	-	W144R	145	145	-
W152R	130	130	-	W153R	186	186	-	W154R	186	186	-
W162R	123	123	-	W163R	180	180	-	W164R	181	181	-
ST	Lubrication types			ST	Lubrication types			ST	Lubrication types		
3	LB ₁	LP ₂	LI ₃	4	LB ₁	LP ₂	LI ₃	4	LB ₁	LP ₂	LI ₃
W013T	13	13	27	W014T	-	-	-	W014T	-	-	-
W023T	13	13	29	W024T	-	-	-	W024T	-	-	-
W033T	21	21	45	W034T	21	21	45	W034T	21	21	45
W043T	22	22	47	W044T	21	21	47	W044T	21	21	47
W053T	33	33	69	W054T	44	33	69	W054T	44	33	69
W063T	35	35	73	W064T	46	34	73	W064T	46	34	73
W073T	63	63	126	W074T	82	62	126	W074T	82	62	126
W083T	60	60	122	W084T	78	60	122	W084T	78	60	122
W093T	75	75	154	W094T	102	74	155	W094T	102	74	155
W103T	74	74	152	W104T	98	73	152	W104T	98	73	152
W113T	102	102	213	W114T	142	102	213	W114T	142	102	213
W123T	102	102	210	W124T	141	101	211	W124T	141	101	211
W133T	151	151	316	W134T	205	150	316	W134T	205	150	316
W143T	146	146	306	W144T	201	147	309	W144T	201	147	309
W153T	188	188	388	W154T	251	187	390	W154T	251	187	390
W163T	182	182	377	W164T	244	181	379	W164T	244	181	379

Table 2 - Oil volume table – P1 mounting position

WG50	Oil volume table - P2 Mounting Position										
	Oil Volume [L]										
	ST	Lubrication types			ST	Lubrication types			ST	Lubrication types	
2	LB ₁	LP ₂	LI ₃	3	LB ₁	LP ₂	LI ₃	4	LB ₁	LP ₂	LI ₃
W012P	-	-	15	W013P	-	-	18	W014P	-	-	-
W022P	-	-	16	W023P	-	-	19	W024P	-	-	-
W032P	-	-	25	W033P	-	-	31	W034P	-	-	31
W042P	-	-	26	W043P	-	-	33	W044P	-	-	32
W052P	-	-	37	W053P	-	-	51	W054P	-	-	50
W062P	-	-	38	W063P	-	-	53	W064P	-	-	52
W072P	-	-	62	W073P	-	-	86	W074P	-	-	85
W082P	-	-	65	W083P	-	-	90	W084P	-	-	89
W092P	-	-	78	W093P	-	-	104	W094P	-	-	105
W102P	-	-	80	W103P	-	-	107	W104P	-	-	105
W112P	-	-	105	W113P	-	-	144	W114P	-	-	141
W122P	-	-	108	W123P	-	-	149	W124P	-	-	145
W132P	-	-	152	W133P	-	-	213	W134P	-	-	207
W142P	-	-	159	W143P	-	-	218	W144P	-	-	212
W152P	-	-	201	W153P	-	-	275	W154P	-	-	269
W162P	-	-	207	W163P	-	-	279	W164P	-	-	273
ST	Lubrication types			ST	Lubrication types			ST	Lubrication types		
2	LB ₁	LP ₂	LI ₃	3	LB ₁	LP ₂	LI ₃	4	LB ₁	LP ₂	LI ₃
W012R	-	-	17	W013R	-	-	20	W014R	-	-	-
W022R	-	-	18	W023R	-	-	18	W024R	-	-	-
W032R	-	-	26	W033R	-	-	31	W034R	-	-	31
W042R	-	-	26	W043R	-	-	34	W044R	-	-	34
W052R	-	-	38	W053R	-	-	50	W054R	-	-	50
W062R	-	-	39	W063R	-	-	53	W064R	-	-	53
W072R	-	-	62	W073R	-	-	86	W074R	-	-	86
W082R	-	-	65	W083R	-	-	89	W084R	-	-	89
W092R	-	-	79	W093R	-	-	104	W094R	-	-	104
W102R	-	-	82	W103R	-	-	107	W104R	-	-	107
W112R	-	-	110	W113R	-	-	144	W114R	-	-	144
W122R	-	-	113	W123R	-	-	149	W124R	-	-	149
W132R	-	-	157	W133R	-	-	214	W134R	-	-	213
W142R	-	-	164	W143R	-	-	219	W144R	-	-	218
W152R	-	-	207	W153R	-	-	273	W154R	-	-	274
W162R	-	-	210	W163R	-	-	277	W164R	-	-	278
ST	Lubrication types			ST	Lubrication types			ST	Lubrication types		
3	LB ₁	LP ₂	LI ₃	4	LB ₁	LP ₂	LI ₃	4	LB ₁	LP ₂	LI ₃
W013T	-	-	18	W014T	-	-	-	W014T	-	-	-
W023T	-	-	19	W024T	-	-	-	W024T	-	-	-
W033T	-	-	32	W034T	-	-	32	W034T	-	-	32
W043T	-	-	33	W044T	-	-	33	W044T	-	-	33
W053T	-	-	50	W054T	-	-	50	W054T	-	-	50
W063T	-	-	53	W064T	-	-	52	W064T	-	-	52
W073T	-	-	85	W074T	-	-	85	W074T	-	-	85
W083T	-	-	89	W084T	-	-	89	W084T	-	-	89
W093T	-	-	103	W094T	-	-	104	W094T	-	-	104
W103T	-	-	106	W104T	-	-	107	W104T	-	-	107
W113T	-	-	143	W114T	-	-	143	W114T	-	-	143
W123T	-	-	148	W124T	-	-	148	W124T	-	-	148
W133T	-	-	211	W134T	-	-	212	W134T	-	-	212
W143T	-	-	218	W144T	-	-	220	W144T	-	-	220
W153T	-	-	271	W154T	-	-	273	W154T	-	-	273
W163T	-	-	275	W164T	-	-	277	W164T	-	-	277

Table 3 - Oil volume table – P2 mounting position

WG50	Oil volume table - P3 Mounting Position										
	Oil Volume [L]										
	ST	Lubrication types			ST	Lubrication types			ST	Lubrication types	
2	LB ₁	LP ₂	LI ₃	3	LB ₁	LP ₂	LI ₃	4	LB ₁	LP ₂	LI ₃
W012P	11	-	-	W013P	13	-	-	W014P	-	-	-
W022P	11	-	-	W023P	13	-	-	W024P	-	-	-
W032P	17	-	-	W033P	20	-	-	W034P	20	-	-
W042P	18	-	-	W043P	22	-	-	W044P	21	-	-
W052P	23	-	-	W053P	31	-	-	W054P	40	-	-
W062P	24	-	-	W063P	33	-	-	W064P	42	-	-
W072P	43	-	-	W073P	57	-	-	W074P	70	-	-
W082P	41	-	-	W083P	54	-	-	W084P	68	-	-
W092P	52	-	-	W093P	68	-	-	W094P	88	-	-
W102P	52	-	-	W103P	67	-	-	W104P	87	-	-
W112P	69	-	-	W113P	96	-	-	W114P	123	-	-
W122P	68	-	-	W123P	95	-	-	W124P	122	-	-
W132P	100	-	-	W133P	142	-	-	W134P	182	-	-
W142P	97	-	-	W143P	137	-	-	W144P	175	-	-
W152P	130	-	-	W153P	178	-	-	W154P	224	-	-
W162P	124	-	-	W163P	173	-	-	W164P	218	-	-
ST	Lubrication types			ST	Lubrication types			ST	Lubrication types		
2	LB ₁	LP ₂	LI ₃	3	LB ₁	LP ₂	LI ₃	4	LB ₁	LP ₂	LI ₃
W012R	11	-	-	W013R	12	-	-	W014R	-	-	-
W022R	11	-	-	W023R	13	-	-	W024R	-	-	-
W032R	16	-	-	W033R	20	-	-	W034R	20	-	-
W042R	16	-	-	W043R	22	-	-	W044R	21	-	-
W052R	23	-	-	W053R	31	-	-	W054R	31	-	-
W062R	24	-	-	W063R	32	-	-	W064R	32	-	-
W072R	43	-	-	W073R	56	-	-	W074R	56	-	-
W082R	41	-	-	W083R	54	-	-	W084R	54	-	-
W092R	53	-	-	W093R	68	-	-	W094R	68	-	-
W102R	52	-	-	W103R	66	-	-	W104R	66	-	-
W112R	69	-	-	W113R	96	-	-	W114R	96	-	-
W122R	69	-	-	W123R	94	-	-	W124R	94	-	-
W132R	100	-	-	W133R	142	-	-	W134R	142	-	-
W142R	97	-	-	W143R	137	-	-	W144R	137	-	-
W152R	130	-	-	W153R	176	-	-	W154R	177	-	-
W162R	123	-	-	W163R	171	-	-	W164R	172	-	-
ST	Lubrication types			ST	Lubrication types			ST	Lubrication types		
3	LB ₁	LP ₂	LI ₃	4	LB ₁	LP ₂	LI ₃	4	LB ₁	LP ₂	LI ₃
W013T	12	-	-	W014T	-	-	-	W014T	-	-	-
W023T	12	-	-	W024T	-	-	-	W024T	-	-	-
W033T	20	-	-	W034T	20	-	-	W034T	20	-	-
W043T	21	-	-	W044T	20	-	-	W044T	20	-	-
W053T	29	-	-	W054T	29	-	-	W054T	29	-	-
W063T	31	-	-	W064T	31	-	-	W064T	31	-	-
W073T	54	-	-	W074T	54	-	-	W074T	54	-	-
W083T	51	-	-	W084T	52	-	-	W084T	52	-	-
W093T	65	-	-	W094T	67	-	-	W094T	67	-	-
W103T	63	-	-	W104T	65	-	-	W104T	65	-	-
W113T	92	-	-	W114T	93	-	-	W114T	93	-	-
W123T	91	-	-	W124T	92	-	-	W124T	92	-	-
W133T	136	-	-	W134T	138	-	-	W134T	138	-	-
W143T	132	-	-	W144T	135	-	-	W144T	135	-	-
W153T	169	-	-	W154T	172	-	-	W154T	172	-	-
W163T	164	-	-	W164T	168	-	-	W164T	168	-	-

Table 4 - Oil volume table – P3 mounting position

WG50	Oil volume table - P4 Mounting Position										
	Oil Volume [L]										
	ST	Lubrication types			ST	Lubrication types			ST	Lubrication types	
2	LB ₁	LP ₂	LI ₃	3	LB ₁	LP ₂	LI ₃	4	LB ₁	LP ₂	LI ₃
W012P	-	12	19	W013P	-	12	24	W014P	-	-	-
W022P	-	14	21	W023P	-	14	25	W024P	-	-	-
W032P	-	18	29	W033P	-	19	38	W034P	-	19	37
W042P	-	20	31	W043P	-	21	40	W044P	-	20	40
W052P	-	25	41	W053P	-	26	58	W054P	-	26	57
W062P	-	28	44	W063P	-	30	62	W064P	-	30	61
W072P	-	52	83	W073P	-	56	112	W074P	-	56	110
W082P	-	49	79	W083P	-	53	107	W084P	-	53	106
W092P	-	61	96	W093P	-	64	135	W094P	-	64	132
W102P	-	60	95	W103P	-	61	133	W104P	-	61	131
W112P	-	83	131	W113P	-	86	186	W114P	-	86	184
W122P	-	79	129	W123P	-	82	184	W124P	-	82	181
W132P	-	126	192	W133P	-	130	277	W134P	-	130	273
W142P	-	113	184	W143P	-	116	266	W144P	-	116	262
W152P	-	151	242	W153P	-	151	341	W154P	-	151	336
W162P	-	136	228	W163P	-	137	330	W164P	-	137	325
ST	Lubrication types			ST	Lubrication types			ST	Lubrication types		
2	LB ₁	LP ₂	LI ₃	3	LB ₁	LP ₂	LI ₃	4	LB ₁	LP ₂	LI ₃
W012R	-	12	24	W013R	-	12	27	W014R	-	-	-
W022R	-	14	26	W023R	-	14	29	W024R	-	-	-
W032R	-	18	38	W033R	-	19	45	W034R	-	19	45
W042R	-	20	40	W043R	-	21	48	W044R	-	20	47
W052R	-	25	55	W053R	-	26	69	W054R	-	26	69
W062R	-	28	58	W063R	-	30	73	W064R	-	30	73
W072R	-	52	102	W073R	-	56	127	W074R	-	56	127
W082R	-	49	97	W083R	-	53	123	W084R	-	53	123
W092R	-	62	127	W093R	-	64	155	W094R	-	64	155
W102R	-	61	126	W103R	-	61	153	W104R	-	61	153
W112R	-	83	176	W113R	-	86	214	W114R	-	86	214
W122R	-	80	173	W123R	-	82	212	W124R	-	82	211
W132R	-	128	258	W133R	-	130	319	W134R	-	130	318
W142R	-	114	250	W143R	-	116	308	W144R	-	116	307
W152R	-	152	322	W153R	-	151	390	W154R	-	151	391
W162R	-	137	309	W163R	-	137	380	W164R	-	137	380
ST	Lubrication types			ST	Lubrication types			ST	Lubrication types		
3	LB ₁	LP ₂	LI ₃	4	LB ₁	LP ₂	LI ₃	4	LB ₁	LP ₂	LI ₃
W013T	-	12	27	W014T	-	-	-				
W023T	-	14	29	W024T	-	-	-				
W033T	-	19	45	W034T	-	19	45				
W043T	-	21	47	W044T	-	20	47				
W053T	-	26	45	W054T	-	26	46				
W063T	-	30	50	W064T	-	30	50				
W073T	-	56	86	W074T	-	56	86				
W083T	-	53	82	W084T	-	53	82				
W093T	-	64	101	W094T	-	64	101				
W103T	-	61	98	W104T	-	61	98				
W113T	-	86	136	W114T	-	86	136				
W123T	-	82	133	W124T	-	82	133				
W133T	-	130	198	W134T	-	130	209				
W143T	-	116	188	W144T	-	116	203				
W153T	-	151	245	W154T	-	151	262				
W163T	-	137	236	W164T	-	137	253				

Table 5 - Oil volume table – P4 mounting position

WG50	Oil volume table - P5 Mounting Position										
	Oil Volume [L]										
	ST	Lubrication types			ST	Lubrication types			ST	Lubrication types	
2	LB ₁	LP ₂	LI ₃	3	LB ₁	LP ₂	LI ₃	4	LB ₁	LP ₂	LI ₃
W012P	-	16	24	W013P	-	18	28	W014P	-	-	-
W022P	-	17	26	W023P	-	18	29	W024P	-	-	-
W032P	-	28	38	W033P	-	32	45	W034P	-	32	44
W042P	-	29	40	W043P	-	35	48	W044P	-	33	47
W052P	-	38	55	W053P	-	45	70	W054P	-	44	69
W062P	-	41	58	W063P	-	45	74	W064P	-	45	73
W072P	-	68	102	W073P	-	83	128	W074P	-	82	126
W082P	-	62	98	W083P	-	77	123	W084P	-	76	122
W092P	-	84	126	W093P	-	103	155	W094P	-	101	152
W102P	-	82	124	W103P	-	99	153	W104P	-	97	151
W112P	-	119	171	W113P	-	145	214	W114P	-	142	210
W122P	-	114	168	W123P	-	141	212	W124P	-	138	208
W132P	-	171	253	W133P	-	211	318	W134P	-	205	312
W142P	-	162	245	W143P	-	199	307	W144P	-	196	301
W152P	-	208	315	W153P	-	251	392	W154P	-	247	385
W162P	-	199	306	W163P	-	239	381	W164P	-	234	375
ST	Lubrication types			ST	Lubrication types			ST	Lubrication types		
2	LB ₁	LP ₂	LI ₃	3	LB ₁	LP ₂	LI ₃	4	LB ₁	LP ₂	LI ₃
W012R	-	16	24	W013R	-	19	27	W014R	-	-	-
W022R	-	18	26	W023R	-	20	29	W024R	-	-	-
W032R	-	28	38	W033R	-	33	45	W034R	-	32	45
W042R	-	30	40	W043R	-	35	48	W044R	-	34	47
W052R	-	36	55	W053R	-	44	69	W054R	-	44	69
W062R	-	38	58	W063R	-	45	73	W064R	-	45	73
W072R	-	67	102	W073R	-	82	127	W074R	-	82	127
W082R	-	62	97	W083R	-	77	123	W084R	-	77	123
W092R	-	84	127	W093R	-	103	155	W094R	-	103	155
W102R	-	82	126	W103R	-	98	153	W104R	-	98	153
W112R	-	121	176	W113R	-	145	214	W114R	-	145	214
W122R	-	116	173	W123R	-	140	212	W124R	-	140	211
W132R	-	173	258	W133R	-	210	319	W134R	-	209	318
W142R	-	164	250	W143R	-	199	307	W144R	-	199	307
W152R	-	211	322	W153R	-	248	390	W154R	-	249	391
W162R	-	198	309	W163R	-	237	379	W164R	-	237	380
ST	Lubrication types			ST	Lubrication types			ST	Lubrication types		
3	LB ₁	LP ₂	LI ₃	4	LB ₁	LP ₂	LI ₃	4	LB ₁	LP ₂	LI ₃
W013T	-	19	27	W014T	-	-	-	W014T	-	-	-
W023T	-	20	29	W024T	-	-	-	W024T	-	-	-
W033T	-	33	45	W034T	-	33	45	W034T	-	33	45
W043T	-	35	47	W044T	-	34	47	W044T	-	34	47
W053T	-	44	69	W054T	-	44	69	W054T	-	44	69
W063T	-	45	73	W064T	-	45	73	W064T	-	45	73
W073T	-	82	127	W074T	-	82	127	W074T	-	82	127
W083T	-	77	123	W084T	-	77	123	W084T	-	77	123
W093T	-	103	155	W094T	-	103	155	W094T	-	103	155
W103T	-	98	153	W104T	-	98	153	W104T	-	98	153
W113T	-	145	214	W114T	-	145	214	W114T	-	145	214
W123T	-	140	212	W124T	-	140	211	W124T	-	140	211
W133T	-	210	319	W134T	-	209	318	W134T	-	209	318
W143T	-	199	307	W144T	-	199	307	W144T	-	199	307
W153T	-	248	390	W154T	-	249	391	W154T	-	249	391
W163T	-	237	379	W164T	-	237	380	W164T	-	237	380

Table 6 - Oil volume table – P5-P6 mounting position

In changes, the oil must be drained still “warm”, because thus the viscosity of the oil is lower, facilitating flow and cleaning.

Note: The lubricant used must be destined according to current legislation and guidelines contained in item 10 of this manual.

In case of unfavorable working environment conditions (high humidity, aggressiveness, dust), lubricant change time can be reduced. In this case, the WEG must be consulted.

When changing, the same oil indicated on the gearbox plate and specified in item 5 of this manual must be used. Do not mix oils of different types and manufacturers.

The oil change time is defined as a function of the operating temperature, according to table 7.

Operating temperature	CLP mineral oil	Synthetic Oil CLP HC Hydrocarbons	Synthetic oil CLP PG Polyglycol
+80°C	5.000 hours	15.000 hours	25.000 hours
+85°C	3.500 hours	10.000 hours	18.000 hours
+90°C	2.500 hours	7.500 hours	13.000 hours
+95°C	----	6.000 hours	8.500 hours
+100°C	----	3.800 hours	6.000 hours
+105°C	----	2.500 hours	4.000 hours
+110°C	----	2.000 hours	3.000 hours

Table 7 - Oil change time

Note: On the nameplate (page 17 of this manual) the type of oil recommended for the gearbox (CLP=Mineral; CLP HC=Synthetic; CLP PG= Synthetic) is informed.

Labyrinth Seal

Labyrinth or TACONITE sealing is recommended for environments with a high concentration of suspended powder. It has a grease chamber that prevents the entry of external contaminants into the gearbox. This type of seal is illustrated in Figure 2.

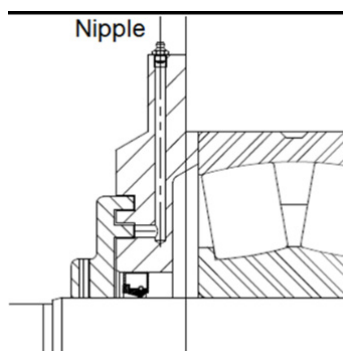

Figure 2 - Taconite or Labyrinth seal

The following recommendations must be followed in order for the labyrinth seal to be efficient:

- The standard labyrinth seal is already provided with an initial load of NLGI #2EP mineral grease. It is not necessary to add grease before starting-up the equipment.
- Table 8 indicates the lubrication time. Table 9 shows the recommended type of grease. In environments with a high degree of contamination, a shorter lubrication time may be required.
- If the gearbox is stopped for more than 6 months apply a thin layer of grease to the outer surface of the seal to prevent hardening. Before starting-up the gearbox, check the integrity of the seal, and replace if necessary; remove all old grease and add new grease to the seal.
- The new grease must be added by Nipple rotating the shaft so that an even distribution of the grease occurs and until the old grease begins to be expelled through the labyrinth. Clean excess grease before gearbox operation starts

Axle rotation in rpm	Operating time in hours
Up to 750	5000
From 750 up to 3600	3000

Table 8 - Lubrication Time

GREASE	BP	CASTROL	TEXACO	MOBIL	SHELL
MINERAL	ENERGREASE LS EP2	TRIBOL 3020/1000-2	MULTIFAK EP2	BEACON EP2	ALVANIA EP2
Feeding Grade			FM EP2		

Table 9 - Grasas recomendadas NLGI #2

5. Gearbox Description

5.1. Gearbox nameplate

The gearboxes are provided with an identification plate (Figure below) and in the case of motorized gearboxes, they are provided with two identification plates, one of the gearbox and one of the motor (according to the manufacturer's standard). The nameplates contain symbols and values that determine the characteristics of the gearbox and motor.

The data contained in the Gearbox Identification Plate are shown in Figure 3.

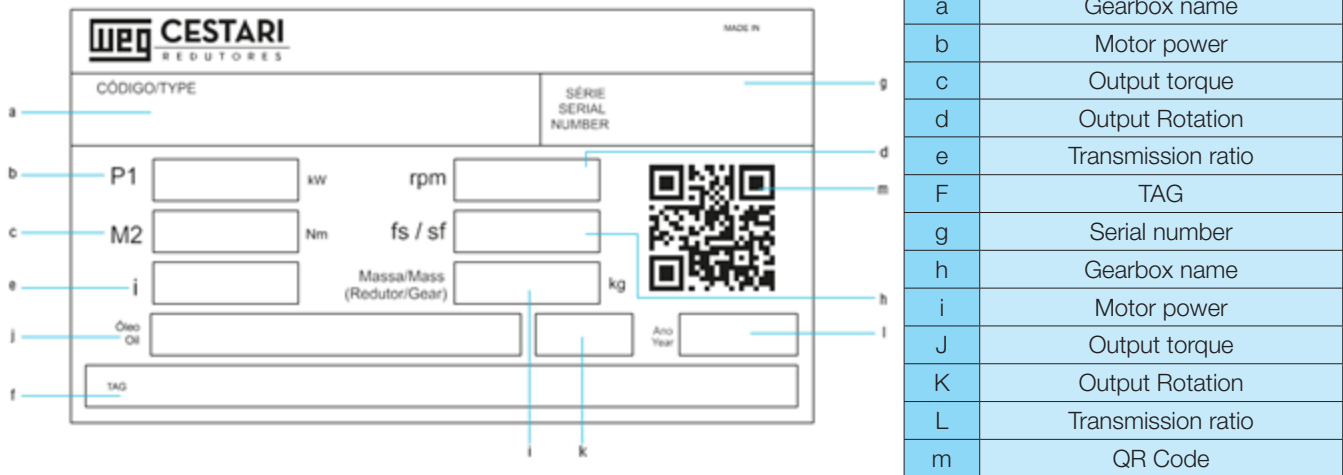

Figure 3 - Nameplate data

6. Installation

The tips of the shafts are protected with a thin layer of anti-corrosion oil, this oil must be removed before installation, using normal solvents (varsol, turpentine or other similar).



ATTENTION!

The solvent cannot reach the retainers and never use sandpaper to remove the varnish.

The gearboxes must be installed in the correct working position (as requested in the Commercial Proposal) (Working positions see page 18), on a flat and rigid basis (to avoid additional stresses and strains), allowing easy access to the lubrication devices.

When mounting the gearbox via torsion arm, the mounting side of the torsion arm shall be on the same input side as the output shaft.

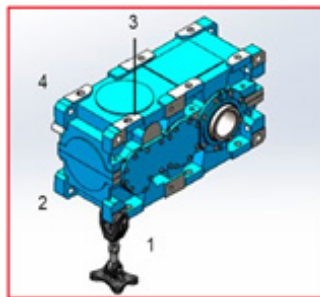
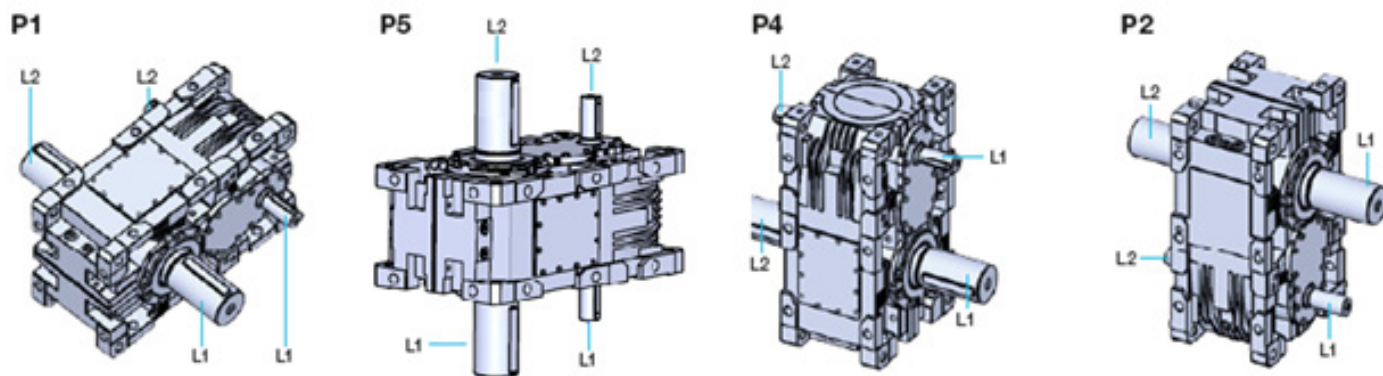
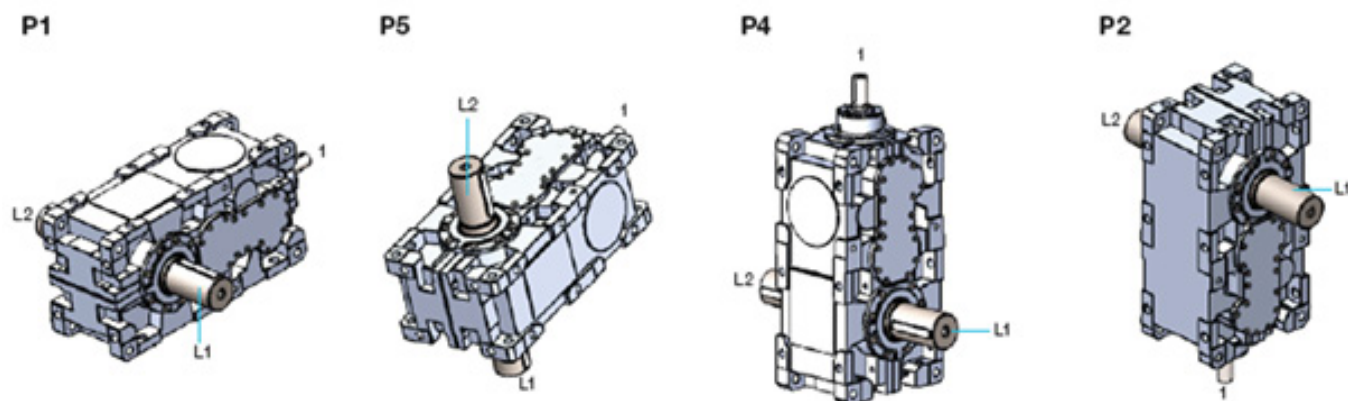

Figure 4 - Assembly through the torsion arm

Parallel Axles



Orthogonal Axles R



Orthogonal Axles T

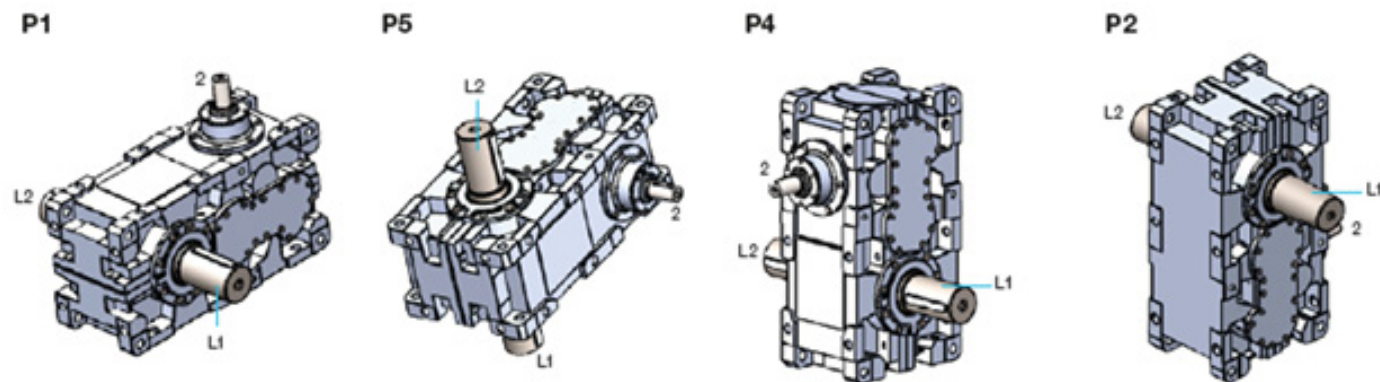

Figure 5 - Mounting positions

When the motor is mounted vertically (shaft down), it is recommended to wear a protective hat for the motor.

For vertical mounting position P2, P4, P5, the use of lubrication system must be evaluated.

Mounting position P1 is suitable for mounting surface S1 and S3.

The mounting position P2 is suitable for the mounting surface S2.

The mounting position P4 is fitted to the mounting surface S4.

Mounting position P5 is suitable for mounting surface S5 and S6.

Other mounting position/mounting surface combinations refer to WEG.

The WG50 gearbox housings are symmetrical allowing for flexible (flip) assembly, i.e. from S1 to S3 and from S3 to S1 (Mounting surfaces on page 17); consult WEG for fitment of accessories and options according to the new position.

The assembly of the gearbox on the machine can be done by coupling or through transmission elements such as: pulleys, sprockets, etc.

In the direct connection, there is the rigid coupling and the elastic; the rigid requires precision in the alignment between the shaft of the gearbox and the driven machine; the elastic is most indicated when it is desired to compensate for small longitudinal, radial and angular movements of the shafts, in addition to absorbing starting and reversal shocks (see the permissible misalignment in the coupling manufacturer’s catalog).

When it is desired to transmit power with speed ratio, it is necessary to use sprockets or gears mounted on the output shaft of the geared motor or gearbox. For this purpose, it will be necessary to observe the parallelism between the axes involved, also verifying the minimum permissible diameter (D_{min} , mm) of the transmission element through the following equation

$$D_{min} = \frac{2000 \cdot Mc}{Fr} \cdot kr$$

- Where:**
- Mc = Moment to be transmitted (Nm).
 - Fr = Allowable radial load on the output axle of the gearbox (N).
 - Kr = Additional factor.

Values for the factor kr:

- Flat belt with tensioner: 2.5
- Flat belt without tensioner: 5
- Trapezoidal belt without tensioner: 1.75
- Roller chain or silent chain: 1.4
- Gears: 1.15

The elements to be mounted on the axles, such as couplings, pulleys, sprockets, etc., must have the holes machined with tolerance H7, their weights and dimensions compatible with the gearbox and mounted with slight interference, and must be as close as possible to the axle backrest, as shown in figure 6.

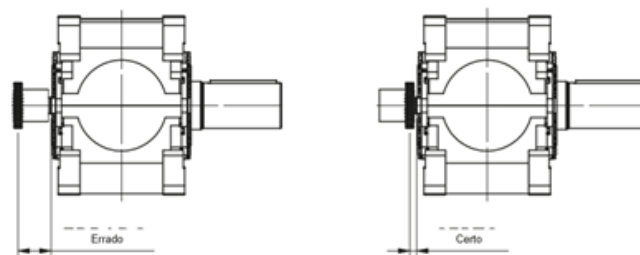

Figure 6 - Assembly of elements on the shaft

In interference assemblies, the “invitation” is recommended in the hole according to figure 7:

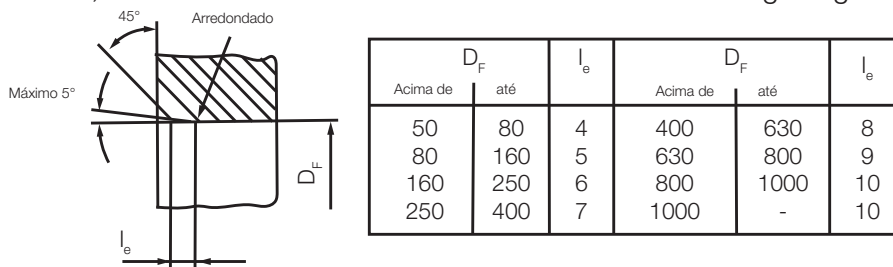

Figure 7 - Invitation

The use of a hammer in the assembly of these elements can damage the bearings and teeth of the gearbox gears.

Axle-mounted elements must be carefully aligned (even if it is elastic coupling) to avoid additional vibrations and stresses. It is advisable to heat the part to be assembled up to about 100°C; the center hole threaded at the end of the gearbox shaft can be used to assist in the assembly, then making the necessary locking to avoid axial displacement of the transmission element.

**ATTENTION !**

In accordance with accident prevention regulations, protect all rotating parts by means of protections installed against unwanted contact and against falling objects on the transmission element, meeting at least the protection requirements (in Brazil according to NR12 and/or according to work safety standards applicable to the country where the product will be installed and used).

Assembly by means of blows is inadmissible, as this method damages bearings and gear teeth. When direct coupling is not used, between the gearbox and the driven machine, depending on the direction of rotation, the drive must be such that the forces coming from the transmission element press the gearbox against the fixing base. Note in the examples in figure 8 the appropriate and recommended arrangement:

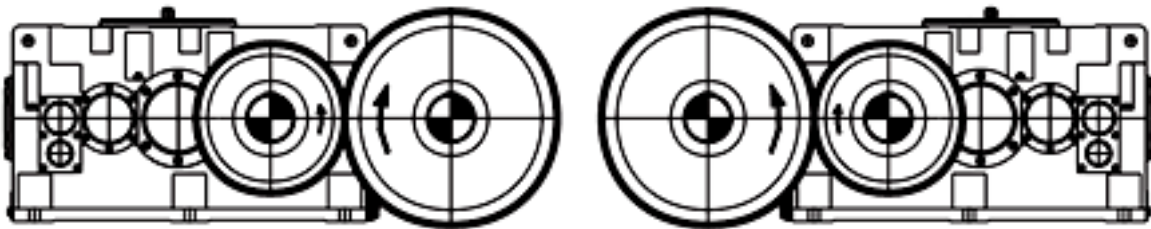

Figure 8 - Assembly of transmission element

In the case of gearboxes with a hollow axle, do not mount the gearbox/geared motor on the equipment through blows. To avoid contact oxidation and assembly difficulties, it is recommended to apply and spread antioxidant greases (such as Dow Corning Molykote G-Rapid Plus or similar) on the shaft, housing and key.

If the gearbox is, for some reason, repainted, the retainers must be isolated to avoid dryness caused by the paint which causes leakage by the retainers.

The fan and motor fins must be kept clean and free to allow perfect cooling; the clearance between the air inlet and the wall must be at least 30 mm.

For more information on the dimensions and tolerances of the tips of the input and output shafts of the geared motors and gearboxes, please consult the WEG technical catalog available on the website: www.weg.net in the "downloads center".

Industrial gearboxes must be installed on a level base (0.01 mm/100mm). When the gearbox is specified to work in an inclined plane, do not install it with an inclination angle other than that specified. For standard gearboxes, the installation angle must be within the limits shown in figure 9.

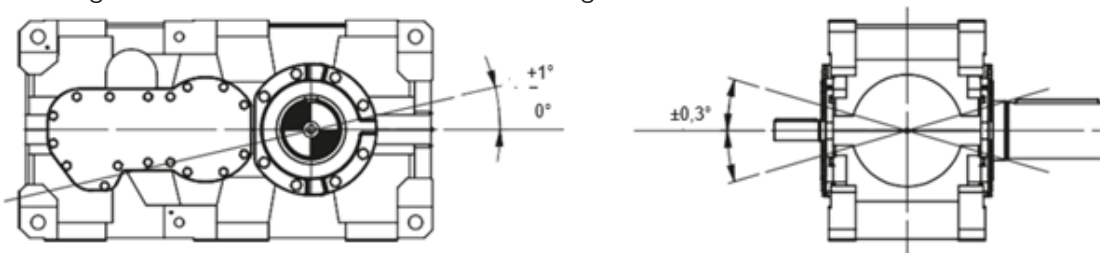

Figure 9 - Installation angle for standard gearboxes

The equipment where the gearbox is being fixed must provide for a correct positioning of the fixing holes, noting that all flange holes or gearbox shoes, see figure 10, must be used, so there is no concentration of efforts.

The screws to be used in the fastening feet of the gearbox are as shown in figure 10, they must have a minimum resistance class 8.8 and tightening torque as shown in table 10.

Size	Mounting Position				Tightening torque [Nm] CR 8.8
	P1	P2	P4	P5 / P6	
W01	M20x060	Rosca M20x2.5x32	M20x090	M20x070	410
W02	M20x060	Rosca M20x2.5x32	M20x090	M20x070	410
W03	M24x070	Rosca M24x3,0x37	M24x100	M24x090	710
W04	M24x070	Rosca M24x3,0x37	M24x100	M24x090	710
W05	M30x085	Rosca M30x3.5x47	M30x130	M30x110	1410
W06	M30x085	Rosca M30x3.5x47	M30x130	M30x110	1410
W07	M36x100	Rosca M36x4.0x56	M36x160	M36x140	2460
W08	M36x100	Rosca M36x4.0x56	M36x160	M36x140	2460
W09	M36x110	Rosca M36x4.0x56	M36x160	M36x140	2460
W10	M36x110	Rosca M36x4.0x56	M36x160	M36x140	2460
W11	M42x120	Rosca M42x4.5x65	M42x190	M42x150	3950
W12	M42x120	Rosca M42x4.5x65	M42x190	M42x150	3950
W13	M42x120	Rosca M42x4.5x65	Rosca M42x4.5x65	M42x170	3950
W14	M42x120	Rosca M42x4.5x65	Rosca M42x4.5x65	M42x170	3950
W15	M48x130	Rosca M48x5.0x75	Rosca M48x5.0x75	M48x180	5950
W16	M48x130	Rosca M48x5.0x75	Rosca M48x5.0x75	M48x180	5950

Table 10 - Screws for WG50 gearbox mounting feet

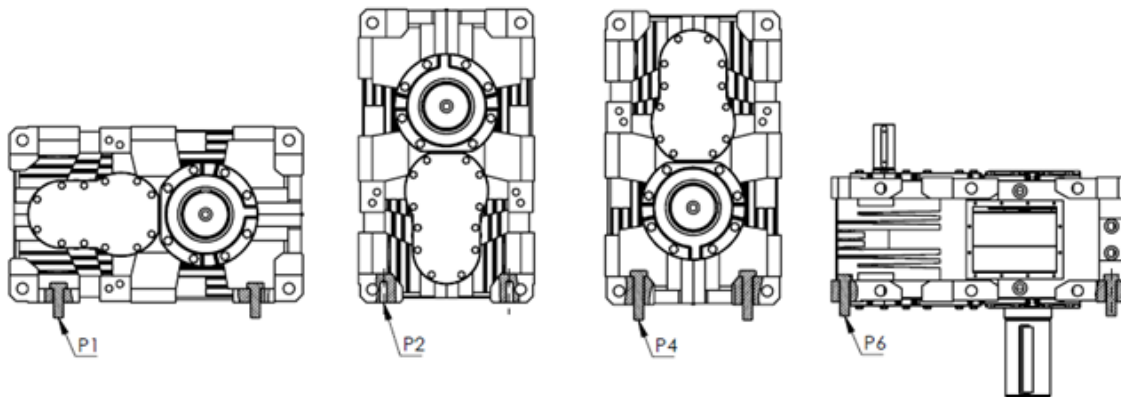

Figure 10 - Positioning of the fastening holes

When the gearbox is supplied with a shrink disc, the assembly instructions of the SHRINK DISC available on the website: www.weg.net in the “downloads center” section, must be read, understood and adopted.

The key of the gearbox is according to DIN 6885 (Flat Keys – DIN 6885 standard sheet 1) and the metric thread of the tip according to DIN 332 (Center holes 60° with metric thread – DIN 332 standard sheet 2 form D).

Check that the working position and the fastening of the gearbox are correct. Check that all fastening screws are correctly tightened. When the gearboxes are put into operation, they must work without load for a few hours; if there is no abnormality, load is gradually placed until it reaches its total.



ATTENTION!

The items listed above are valid only for the proper functioning of the gearbox, leaving the specifications for the general operation to the equipment manufacturer.

7. Operation

Before starting the operation, it must be checked that the gearbox is filled with oil and that the lubricant level is adequate as recommended (see item 4.4 of this manual).

Observe if the gearbox rotates freely. Analyze whether the connection scheme performed is in accordance with that indicated on the motor nameplate (item 5) for the desired voltage.

Check that the screws, nuts and connections of the motor terminals and screws and mounting nuts of the gearbox are properly tightened (see item 6 Installation).

Identify the desired direction of rotation by activating the uncoupled gearbox of the equipment, if the inversion of the direction of rotation is necessary, any two phases must be reversed.

When starting the operation of the gearbox, the oil temperature rises gradually, until it stabilizes after approximately 3 hours, reaching the operating temperature (see item 4.4).

8. Maintenance

Periodic preventive maintenance is mainly aimed at verifying the operating conditions of the gearbox. It must be carried out by qualified persons.

There are no strict rules to follow when addressing inspection programs. The periods or intervals, the types of examinations to be performed can be extended or reduced according to the working conditions and place where the gearbox is installed.

It is recommended that each gearbox has its own type of annotation, such as a plug, cards or label. The important thing is to record all the maintenance performed, the parts exchanged and the dates on which they were performed. The analysis of these notes would allow relocation and adjustments in the maintenance program.

Table 11 shows a basic program for inspection, containing the items to be inspected and the suggested time intervals; however, such intervals are flexible, prolonged or reduced, according to the conditions of the place where the gearmotor/gearbox is installed:

Items to check	Procedures	Frequency
Mechanical conditions	Check for abnormal noise or vibration, oil leakage, also inspect the condition of the transmission system for lubrication and alignment.	Weekly
Place where the geared motor is installed	Identify the existence of water or vapors near the geared motor, excessive dust, chips or residues, check the gearbox vent, unplugging it if necessary, check the ventilation conditions of the electric motor.	Weekly
Oil level	Check the oil level and fill it if necessary.	Weekly
Geared motor fastening screws	Check that the geared motor fastening screws are not loosened by vibration.	Monthly
Terminals and screws	Observe that, due to vibration, there has been no loosening of the screws and connection bridges, making poor contact and damaging the power supply	Monthly
Mechanical conditions	Check the condition of the transmission elements, replacing them if necessary, cleaning the geared motor housing and covers. Check for misalignment or rubbing	Weekly

Table 11 - Programa básico de inspección

Table 12 shows the main defects in gearboxes, their causes and corrective actions

SYMPTOMS	CAUSES		CORRECTIVE MEASURES
Overheating	Overload	Load exceeds gearbox capacity	Check the capacity indicated on the gearbox nameplate, replace with a unit of sufficient capacity, or reduce the load
	Improper lubrication	Insufficient oil volume	Check the oil level, adjust the level to the correct position
		Too much oil in the gearbox causes excessive agitation, heat generation and gases inside the housing	
		Out-of-specification oil	Drain and refill to the proper oil level, with the oil indicated on the nameplate of the gearbox or similar
Oil loss	Worn or defective retainers	Excessive quantity of oil	Check level and drain to indicated level
		Air inlet respirators Obstructed exhaust gas ventilation	Clean or replace the vent, use a non-flammable solvent for cleaning
		Insufficient sealing layers between box surfaces	Replace worn retainers with new ones. Apply new sealing coat, permatex or equivalent, assemble the assembly. Always assemble the retainers with grease on the sealing lips.
Excessive noise and vibration	Irregularity in the fastening screws	Inverted installation	Check the tightness of the screws and that the anchors are secure in their foundations or frames. Check unit alignment and spacer sheets or shims
	Bearing failure	Bearing fatigue, check for wear on balls, rollers or tracks. Wear can be due to dirt in the oil	Replace the worn bearings, clean the entire interior of the gearbox and replace the new oil, as specified
		Peeling, scored, or bruised bearing tracks usually indicate overloading	Replace worn bearings, check and repair bearing play, coupling alignment, and gearbox shaft loads
		Bearing cage failure also indicates overloading	
	Excessive gear wear	Overloading causes pitting of teeth (brushing, small holes)	Check the loads, change the gears or replace them with a gearbox of adequate capacity
	Insufficient oil quantity	Oil below normal level can cause noise	Check oil level and bring it up to the proper level
	Part losses	Excessive shocks or imperfect connection with other elements	Inspect the gearbox for broken parts, loose bolts, nuts or damaged threads. Check alignment with driven machine. Check keys and tolerances
High axles speed	Excessive tension on belts or drive chains	Check speeds indicated on the nameplate. check tensions	
Excessive axle backlash	Bearings exposed to abrasive elements cause wear on balls, rollers and tracks		Replace worn bearings. Clean all housing internals, feed unit with recommended oil, replace worn gears and keys.
Excessive gear backlash	Worn gears and keys or lost screws cause backlash (gear backlash) backlash increases with number of gear sets		Replace worn gears and keys. Tighten all unit screws.

Table 12 - Main defects in gearboxes, their causes and corrective actions

8.1. Disassembly and assembly of gears and bearings

Disassembly

In the disassembly of gears and bearings of their respective shafts it is advisable that this operation is done in a hydraulic press.

The surfaces of the shaft by which the gears or bearings to be disassembled will be displaced must be covered by a thin layer of oil.

The assembly must be positioned vertically, on the press table, and the force must be gradually increased, until the components are removed from the shaft.

Assembly

The assembly of gears and bearings must be made hot.

The gears must be heated in an oil bath or oven at approximately 150°C, and mounted on their axles by means of a hydraulic press.

Be sure to cover with a thin layer of oil, the surface of the shaft to be mounted.

Take care, so that there is a perfect alignment in the positioning of the shaft on the gear, and position the shaft correctly on the press table (aligned and centered) to avoid damage to the surfaces of the parts, when assembling. Observe very carefully the positioning of the keys.

Bearings must be heated to temperatures that vary according to their size and degree of interference.

The maximum temperature allowed in the bearings is 120°C; temperatures above this value may damage the bearing structure.

During assembly, avoid any type of shock to the bearings; always use appropriate devices for this operation.



ATTENTION!

Whenever there is replacement of components, such as gears, bearings or axles, it is necessary to adjust the axial clearances of the bearings, for WG50 INDUSTRIAL line with self-compensating roller bearings and cylindrical rollers the axial clearance must be at least 0.3 mm and at most 0.4 mm, when it is bearings of the 30000 series (tapered rollers) the clearance must be according to table 13.

2 STAGES - BEARINGS																
TAMAÑO	W01	W02	W03	W04	W05	W06	W07	W08	W09	W10	W11	W12	W13	W14	W15	W16
EJE 3	32308	32308	32310	32310	32312	32312	32314	32314	32317	32317	22320	22320	22322	22322	22324	22324
EJE 4	32311	32311	32313	32313	22316E	22316E	22318E	22318E	22322	22322	22324	22324	22328	22328	22332	22332
EJE 5 - SÓLIDO	32022	32024	32026	32028	23030	23032	23130	23134	23136	23136	22240	22240	22244	22248	22248	22252
EJE 5 - HUECO	32022	32024	32026	32028	23030	23032	NCF 2936	NCF 2940	NCF 2944	NCF 2944	NCF 2952	NCF 2952	NCF 2956	NCF 2956	NCF 2960	NCF 2964
AXIAL ADJUSTMENT																
TAMAÑO	W01	W02	W03	W04	W05	W06	W07	W08	W09	W10	W11	W12	W13	W14	W15	W16
EJE 3	0,065	0,065	0,075	0,075	0,090	0,090	0,095	0,095	0,110	0,110	0,400	0,400	0,400	0,400	0,400	0,400
EJE 4	0,075	0,075	0,090	0,090	0,400	0,400	0,400	0,400	0,400	0,400	0,400	0,400	0,400	0,400	0,400	0,400
EJE 5 - SÓLIDO	0,080	0,085	0,095	0,100	0,400	0,400	0,400	0,400	0,400	0,400	0,400	0,400	0,400	0,400	0,400	0,400
EJE 5 - HUECO	0,080	0,085	0,095	0,100	0,400	0,400	0,400	0,400	0,400	0,400	0,400	0,400	0,400	0,400	0,400	0,400
3 STAGES - BEARINGS																
TAMAÑO	W01	W02	W03	W04	W05	W06	W07	W08	W09	W10	W11	W12	W13	W14	W15	W16
EJE 1	33207	33207	33208	33208	33210	33210	32310	32310	33213	33213	32313	32313	32316	32316	32316	32316
EJE 3	32307	32307	32309	32309	32311	32311	32313	32313	22316	22316	22318	22318	22322	22322	22322	22322
EJE 4	32311	32311	32313	32313	22316E	22316E	22318E	22318E	22322	22322	22324	22324	22328	22328	22332	22332
EJE 5 - SÓLIDO	32022	32024	32026	32028	23030	23032	23130	23134	23136	23136	22240	22240	22244	22248	22248	22252
EJE 5 - HUECO	32022	32024	32026	32028	23030	23032	NCF 2936	NCF 2940	NCF 2944	NCF 2944	NCF 2952	NCF 2952	NCF 2956	NCF 2956	NCF 2960	NCF 2964
AXIAL ADJUSTMENT																
TAMAÑO	W01	W02	W03	W04	W05	W06	W07	W08	W09	W10	W11	W12	W13	W14	W15	W16
EJE 1	0,050	0,050	0,060	0,060	0,060	0,060	0,080	0,080	0,080	0,080	0,100	0,100	0,120	0,120	0,130	0,130
EJE 3	0,060	0,060	0,070	0,070	0,090	0,090	0,090	0,090	0,400	0,400	0,400	0,400	0,400	0,400	0,400	0,400
EJE 4	0,075	0,075	0,090	0,090	0,400	0,400	0,400	0,400	0,400	0,400	0,400	0,400	0,400	0,400	0,400	0,400
EJE 5 - SÓLIDO	0,080	0,085	0,095	0,100	0,400	0,400	0,400	0,400	0,400	0,400	0,400	0,400	0,400	0,400	0,400	0,400
EJE 5 - HUECO	0,080	0,085	0,095	0,100	0,400	0,400	0,400	0,400	0,400	0,400	0,400	0,400	0,400	0,400	0,400	0,400
4 STAGES - BEARINGS																
TAMAÑO	W01	W02	W03	W04	W05	W06	W07	W08	W09	W10	W11	W12	W13	W14	W15	W16
EJE 1	-	-	33206	33206	33207	33207	33208	33208	32309	32309	32310	32310	32312	32312	32312	32312
EJE 2	-	-	32307	32307	32308	32308	32310	32310	32311	32311	32313	32313	32316	32316	32316	32316
EJE 3	-	-	32309	32309	32311	32311	32313	32313	22316	22316	22318	22318	22322	22322	22322	22322
EJE 4	-	-	32313	32313	22316E	22316E	22318E	22318E	22322	22322	22324	22324	22328	22328	22332	22332
EJE 5 - SÓLIDO	-	-	32026	32028	23030	23032	23130	23134	23136	23136	22240	22240	22244	22248	22248	22252
EJE 5 - HUECO	-	-	32026	32028	23030	23032	NCF 2936	NCF 2940	NCF 2944	NCF 2944	NCF 2952	NCF 2952	NCF 2956	NCF 2956	NCF 2960	NCF 2964
AXIAL CLEARANCES																
EJE	W01	W02	W03	W04	W05	W06	W07	W08	W09	W10	W11	W12	W13	W14	W15	W16
EJE 1	-	-	0,055	0,055	0,060	0,060	0,065	0,065	0,070	0,070	0,080	0,080	0,090	0,090	0,100	0,100
EJE 2	-	-	0,060	0,060	0,065	0,065	0,080	0,080	0,085	0,085	0,095	0,095	0,110	0,110	0,110	0,110
EJE 3	-	-	0,070	0,070	0,090	0,090	0,090	0,090	0,400	0,400	0,400	0,400	0,400	0,400	0,400	0,400
EJE 4	-	-	0,090	0,090	0,400	0,400	0,400	0,400	0,400	0,400	0,400	0,400	0,400	0,400	0,400	0,400
EJE 5 - SÓLIDO	-	-	0,095	0,100	0,400	0,400	0,400	0,400	0,400	0,400	0,400	0,400	0,400	0,400	0,400	0,400
EJE 5 - HUECO	-	-	0,095	0,100	0,400	0,400	0,400	0,400	0,400	0,400	0,400	0,400	0,400	0,400	0,400	0,400

Table 13 - Axial clearances for WG50 gearbox bearings

Arrangements of the axles as shown in Figure 11. For orthogonal gearboxes please consult WEG.

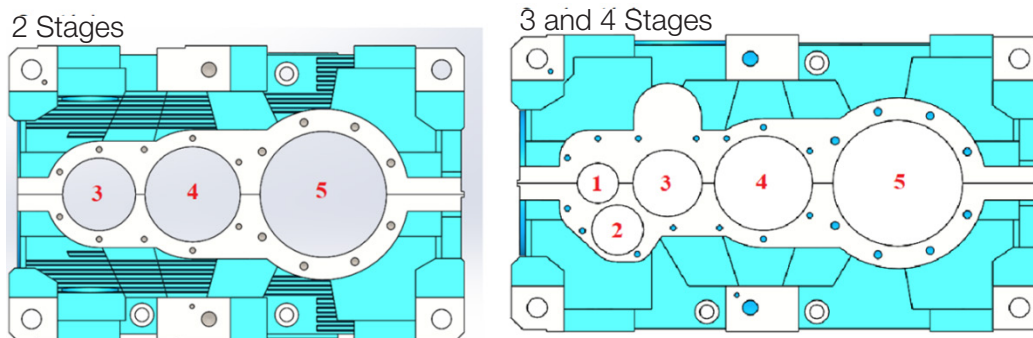

Figure 11 - Arrangements of the axles

9. Repairs

Repairs and eventual disassembly must be carried out by qualified persons. If this is not possible, the gearbox/geared motor must be sent to an Authorized Technical Assistant or WEG to perform the service.

The list of Authorized Technical Assistants and their contact details are available on the website:

<https://www.weg.net/institutional/US/en/contact/service-network>

When it is necessary to replace components, the customer must contact WEG or an Authorized Technical Assistant, providing the serial number of the geared motor/gearbox contained in the geared motor/gearbox identification plate, through which we can more quickly identify the desired component.



ATTENTION!

The replaced components must be destined according to current legislation and guidelines contained in item 10 of this manual.

10. Environmental Guidelines

The products manufactured by WEG meet the legal and environmental requirements defined by the company and as an integral part of our Environmental Management System, the information regarding the recycling of our products is made available in this Manual:

Housings, Couplings, Covers, etc. (Cast Iron, Steel or Aluminum): They are 100% recyclable and should be destined for foundries.

Shafts, Gears, Pinions, etc. (Steel): They are 100% recyclable and should be destined for steel mills.

Crowns (Bronze): They are 100% recyclable and should be destined for foundries.

Oils: They must be intended for re-refining in duly authorized companies.

Seals (Rubber): They must be destined to companies duly licensed by the responsible environmental agency (Class II landfill).

Elastic Elements: They are 100% recyclable and should be destined for recycling companies.

Packaging:

Wood: They are manufactured with reforestation wood and can be reused or destined as fuel in boilers when not contaminated (with oil, grease, paint).

Cardboard: They are 100% recyclable when not contaminated (with oil, grease, paint) and should be destined for recycling companies.

Note: If any material is contaminated with oil, grease, paint, it must be destined to companies duly licensed by the responsible environmental agency. autorizadas por el organismo ambiental responsable.



+55 47 3276.4000



motores@weg.net



Jaraguá do Sul - SC - Brazil

Cod: 50129271 | Rev: 01 | Date (m/a): 10/2023.

The values shown are subject to change without prior notice.
The information contained is reference values.