

AC Drive for Solar Water Pumps

ADV200 SP

Functions description and parameters list

Language: English

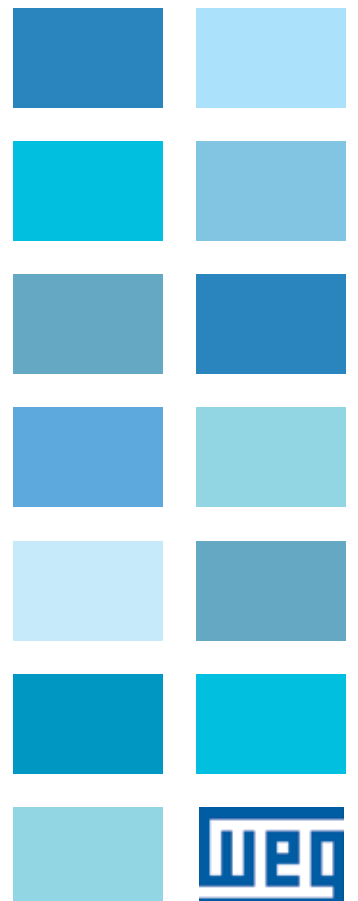

Information about this manual

This manual explains the functions and the description of the parameters.

The informations about mechanical installation, electrical connection and fast start-up can be found on the ADV200 SP Quick start guide.

Software version

This manual is updated according the software version V 2.x.1. + Solar Pump Application V 2.x.46.4.

The identification number of the software version is indicated on the identification plate of the drive or can be checked with the Firmware ver.rel - PAR 490 parameter, menu 2.5.

General information

Note !

In industry, the terms "Inverter", "Regulator" and "Drive" are sometimes interchanged. In this document, the term "Drive" will be used.

Before using the product, read the safety instruction section carefully. Keep the manual in a safe place and available to engineering and installation personnel during the product functioning period.

WEG Automation Europe S.r.l. has the right to modify products, data and dimensions without notice. The data can only be used for the product description and they can not be understood as legally stated propriety

Thank you for choosing this WEG product.

We will be glad to receive any possible information which could help us improving this manual. The e-mail address is the following: techdoc@weg.net.

All rights reserved

Symbols used in the manual



Warning

Indicates a procedure, condition, or statement that, if not strictly observed, could result in personal injury or death.
Indique le mode d'utilisation, la procédure et la condition d'exploitation. Si ces consignes ne sont pas strictement respectées, il y a des risques de blessures corporelles ou de mort.



Caution

Indicates a procedure, condition, or statement that, if not strictly observed, could result in damage to or destruction of equipment.

Indique et le mode d'utilisation, la procédure et la condition d'exploitation. Si ces consignes ne sont pas strictement respectées, il y a des risques de détérioration ou de destruction des appareils.



Indicates that the presence of electrostatic discharge could damage the appliance. When handling the boards, always wear a grounded bracelet.

Indique que la présence de décharges électrostatiques est susceptible d'endommager l'appareil. Toujours porter un bracelet de mise à la terre lors de la manipulation des cartes.



Important

Indicates a procedure, condition, or statement that should be strictly followed in order to optimize these applications.

Indique le mode d'utilisation, la procédure et la condition d'exploitation. Ces consignes doivent être rigoureusement respectées pour optimiser ces applications.

Note !

Indicates an essential or important procedure, condition, or statement.

Indique un mode d'utilisation, de procédure et de condition d'exploitation essentiels ou importants

Table of Contents

Information about this manual	2
Symbols used in the manual.....	2
A – Programming	5
A.1 Menu display modes	5
A.2 Programming of “function block” analog and digital input signals	5
A.3 Variable interconnections mode	5
B – Parameters and functions description (Expert list)	7
Legend.....	7
1 – MONITOR.....	8
2 – DRIVE INFO	11
3 – STARTUP WIZARD	14
4 – DRIVE CONFIG.....	15
5 – REFERENCES	20
6 – RAMPS	25
7 – MULTI REFERENCE	28
8 – MOTORPOTENTIOMETER	31
9 – JOG FUNCTION.....	37
10 – MONITOR FUNCTION	38
11 – COMMANDS.....	42
12 – DIGITAL INPUTS	50
13 – DIGITAL OUTPUTS	52
14 – ANALOG INPUTS.....	54
15 – ANALOG OUTPUTS	62
16 – MOTOR DATA.....	67
18 – SPEED REG GAINS.....	71
19 – REGULATOR PARAM	74
21 – FV PARAMETERS.....	77
22 – FUNCTIONS.....	82
22.1 – FUNCTIONS/SPEED RATIO.....	82
22.2 – FUNCTIONS/INERTIA COMP	83
22.3 – FUNCTIONS/DC BRAKING	84
22.4 – FUNCTIONS/MOTOR OVERLOAD	87
22.5 – FUNCTIONS/BRES OVERLOAD	90
22.6 – FUNCTIONS/SPEED CAPTURE	91
22.7 – FUNCTIONS/POWER LOSS	94
22.8 – FUNCTIONS/COMPARE.....	101
22.9 – FUNCTIONS/PADS	103
22.10 - FUNCTIONS/VDC CONTROL	104
22.11 - FUNCTIONS/BRAKE CONTROL.....	105
22.12 - FUNCTIONS/VF ENERGY SAVE	106
22.13 - FUNCTIONS/RTC_SET	108
23 – COMMUNICATION	109
23.1 – COMMUNICATION/RS485.....	109
23.2 – COMMUNICATION/FIELDBUS CONFIG	110
23.3 – COMMUNICATION/FIELDBUS M->S	111
23.4 – COMMUNICATION/FIELDBUS S->M	116
23.5 – COMMUNICATION/WORD COMP.....	119
23.6 – COMMUNICATION/WORD DECOMP.....	120
24 – ALARM CONFIG.....	121
25 – ALARM LOG	133
26 - PROCESS.....	134
26.1 - PROCESS/PID 1 REFERENCES	134
26.2 – PROCESS/ PID 1	138
26.3 – PROCESS/PID 2 REFERENCES	143
26.4 – PROCESS/ PID 2	147
26.5 – PROCESS/SLEEP MODE.....	150
26.6 – PROCESS/FLOW COMPENS	153
26.7 – PROCESS/FILL.....	155
26.8 – PROCESS/MIN FREQUENCY	157
26.9 – PROCESS/CHECK VALVE	158
26.10 – PROCESS/PUMP CLEAN.....	159
26.11 – PROCESS/LOW POWER CALC.....	162
26.12 – PROCESS/FIRE FUNCTION	164
26.13 – PROCESS/TIMERS	165
26.14 – PROCESS/MULTI PUMP	171
27 - SOLAR PUMP	177
27.1 – CONFIGURATION.....	177
27.2 – ALARM	179
27.3 – I/O.....	179
27.4 – SOURCE MANAGER	182

27.5 – VDC CONTROL.....	185
27.6 – MPPT.....	187
27.7 – AUTORESTORE.....	189
27.8 – STABILITY.....	190
27.9 – MONITOR.....	191
27.10 – APP INFO.....	192
PARAMETERS ON SELECTION LISTS, BUT NOT DISPLAYED ON KEYPAD	193
C - Parameter List (Expert).....	201
D – SELECTION LISTS.....	248
L_ANOUT.....	248
L_CMP.....	248
L_DIGSEL1.....	248
L_DIGSEL2.....	249
L_DIGSEL3.....	249
L_DIGSEL4.....	250
L_FBS2M.....	250
L_LIM.....	250
L_MLTREF.....	251
L_PIDFBK.....	251
L_PIDREF.....	251
L_REF.....	251
L_SCOPE.....	252
L_VREF.....	252
L_WDECOMP.....	252
E – TROUBLESHOOTING - Alarms.....	253
F – MESSAGES.....	256
G - Block Diagrams.....	260
System Diagrams Index.....	260
Drive overview.....	260
References.....	261
Ramps.....	262
Multireference.....	262
Motorpotentiometer.....	263
Jog function.....	263
Monitor function.....	264
Commands.....	266
Digital inputs.....	268
Digital outputs.....	269
Analog inputs.....	270
Analog outputs.....	272
Speed reg gains.....	273
VF parameters.....	274
Functions.....	275
Process.....	279
SOLAR PUMPS.....	285

A – Programming

A.1 Menu display modes

The programming menu can be displayed in two modes, which can be selected using the **Access mode** parameter (04 - DRIVE CONFIG menu):

- **Easy** (default) only the main parameters are displayed.
- **Expert** all the parameters are displayed

A.2 Programming of “function block” analog and digital input signals

The signals, variables and parameters of each single “function block” of the drive are interconnected in order to achieve the configurations and controls inside the control system.

These can be managed and modified using the keypad, PC configurator or fieldbus programming.

The programming mode is based on the following logic:

Src (source; i.e.: **Ramp ref 1 src**, PAR: 610)

This term defines **the source of the function block input**, i.e. the signal to be processed in the function block.

The different configurations are defined in the relative **selection lists**.

cfg (configuration; i.e.: **Mpot init cfg**, PAR: 880)

This term refers to **the parameter setting and its effect on the function block**.

For example: Ramp times, internal reference adjustment, etc...

mon (display; i.e.: **Ramp ref 1 mon**, PAR: 620)

This term refers to the **variable output from the function block, which is the result of the calculations performed on the actual block**.

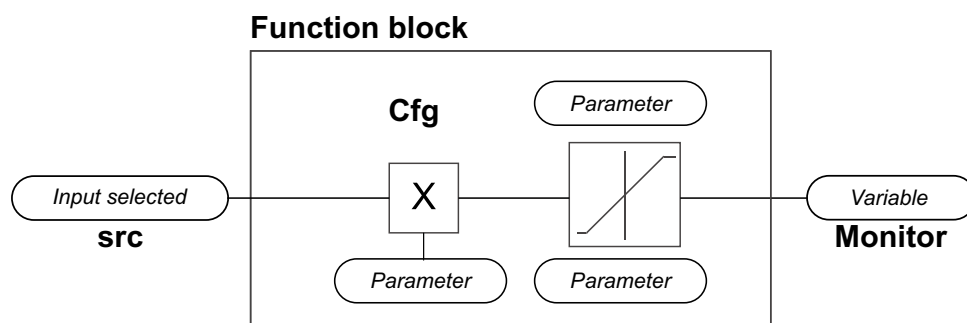

A.3 Variable interconnections mode

The **source (src)** allows the desired control signal to be assigned to the function block input.

This operation is performed by using specific selection lists.

Possible control signal sources:

1 – Physical terminal

The analog and digital signals come from the terminal strip of the regulation card and/or from those of the expansion cards.

2 – Drive internal variables

Internal drive control system variables, from “function block” calculations, sent via keypad, PC configurator or fieldbus.

Practical example

The following examples illustrate the philosophies and methods with which more or less complex operations are performed in the single “function blocks”, the results of which represent the output of the block.

• Example: Changing the Speed Reference source

The main drive reference (in the default configuration) **Ramp ref 1 mon** (PAR: 620) is generated by the output of the function block “**Ramp setpoint Block**”.

Its default source is the **Analog input 1 mon** signal (PAR: 1500), from the output of the function block “**Analog input 1 Block**”, which in this case refers to analog input 1 of the signal terminal strip.

To change the reference source from the analog input to a digital reference inside the drive, the input signal must be changed to “**Ramp setpoint Block**”.

Enter the **Ramp ref 1 src** parameter (PAR: 610) and set a new reference, selecting it from among those listed in the L_MLTREF selection list, for example **Dig ramp ref 1** (PAR: 600).

• Example: Inverting the analog reference signal

To invert the “**Analog input 1 Block**” output signal, the value of the **An inp 1 sign src** parameter (PAR: 1526), which has a default setting of **Null** (no operation), must be changed by selecting the source of the command signal from among those listed in the L_DIGSEL 2 selection list, for example **Digital input X mon, One** (function always enabled), etc.

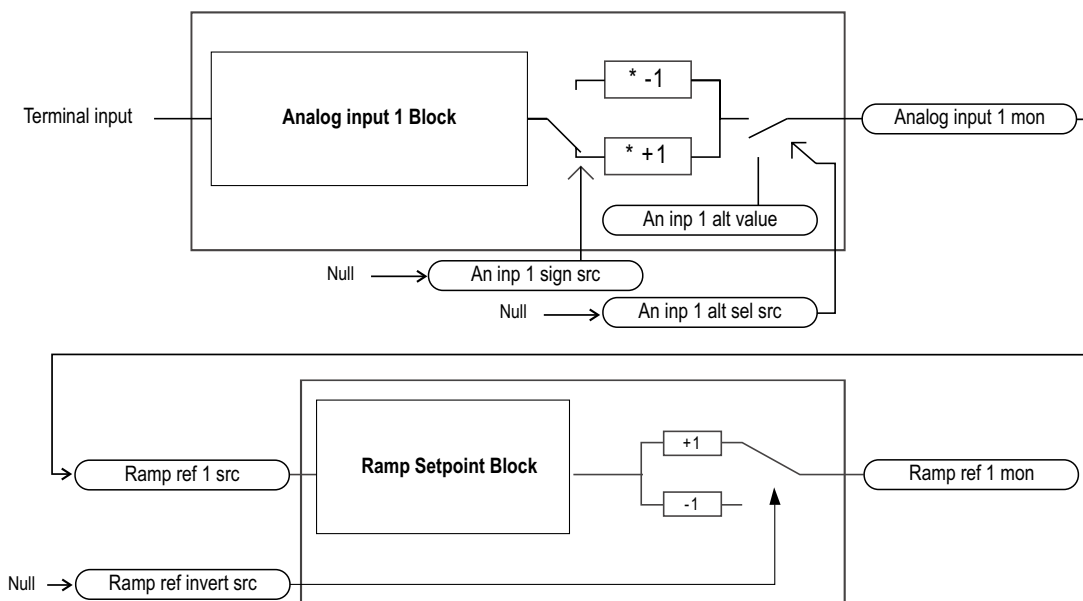

The diagrams above illustrate the internal processing philosophy of the single “function blocks” and the result of these changes on the other interconnected “function blocks”.

Note !

This section contains a brief description of the functions of the other parameters in the function blocks not included for the changes in the example

The **An inp 1 alt sel src** parameter (PAR: 1528) can be used to select an alternative reference for the **Analog input 1 mon** (PAR: 1500) output.

The **An inp 1 alt value** parameter (PAR: 1524) determines the alternative reference value for the **Analog input 1 mon** (PAR: 1500) output.

The **Ramp ref invert src** parameter (PAR: 616) can be used to select the source for the command to reverse the “**Ramp setpoint**” function block output.

The output signal from the “**Ramp setpoint**” block is displayed in the **Ramp ref 1 mon** parameter (PAR: 620).

B – Parameters and functions description (Expert list)

Legend

①	②	③	④	⑤	⑥	⑦	⑧	⑨	⑩		
Menu	PAR	Description	UM	Type	FB BIT	Def	Min	Max	Acc	Mod	
1 - MONITOR											
						(Level 1 menu)					
1.1	250	Output current	A	FLOAT	16/32	0.0	0.0	0.0	R	VS	
1.2	252	Output voltage	V	FLOAT	16/32	0.0	0.0	0.0	R	VS	
22.1 - FUNCTIONS/SPEED RATIO											
						(Level 2 menu)					
22.1.1	3000	Dig speed ratio	perc	INT16	16/32	100	CALCI	CALCI	ERW	VS	
22.1.2	3002	Speed ratio src		LINK	16/32	3000	0	16384	ERW	VS	
L_VREF (Selection List) [*]											

①	Indexing of the menu and parameter
②	Parameter identifier
③	Parameter description
④	UM: unit of measure
⑤	Type of parameter
	BIT Boolean, from modbus seen as 16 bits ENUM Selection list, from modbus seen as 16 bits FLOAT Real, from modbus seen as 32 bits FBM2SIPA 16-bit unsigned integer. Only PAR of existing parameters accepted. FBS2MIPA 16-bit unsigned integer. Only PAR of existing parameters accepted. INT16 Integer with sign 16 bits, from modbus seen as 16 bits INT32 Integer with sign 32 bits, from modbus seen as 32 bits ILINK Selection list, from modbus seen as 16 bits LINK Selection list, from modbus seen as 16 bits UINT16 Integer without sign 16 bits, from modbus seen as 16 bits UINT32 Integer without sign 32 bits, from modbus seen as 32 bits
⑥	Format of data exchanged on Fieldbus (16BIT, 32BIT)

⑥	Default value	CALCF Value calculated as a number with floating point
⑦	Minimum value	CALCI Value calculated as a whole number (Max = 32768)
⑧	Maximum value	SIZE Value depending on the size of the drive
⑨	Accessibility :	E Expert R Read S Size (set value depending on the size of the device) W Write Z parameters that can be modified ONLY with the drive disabled
⑩	Available in regulation mode:	V = V/f Control S = Vect Flux OL
[*]	Selection lists:	The "... src" format parameters are linked to a selection list. The source of the signal that will control the parameter can be selected from the list indicated. The lists are indicated in paragraph C of this manual.

1 – MONITOR

The monitor menu displays the measured values of the sizes and of the drive operating parameters.

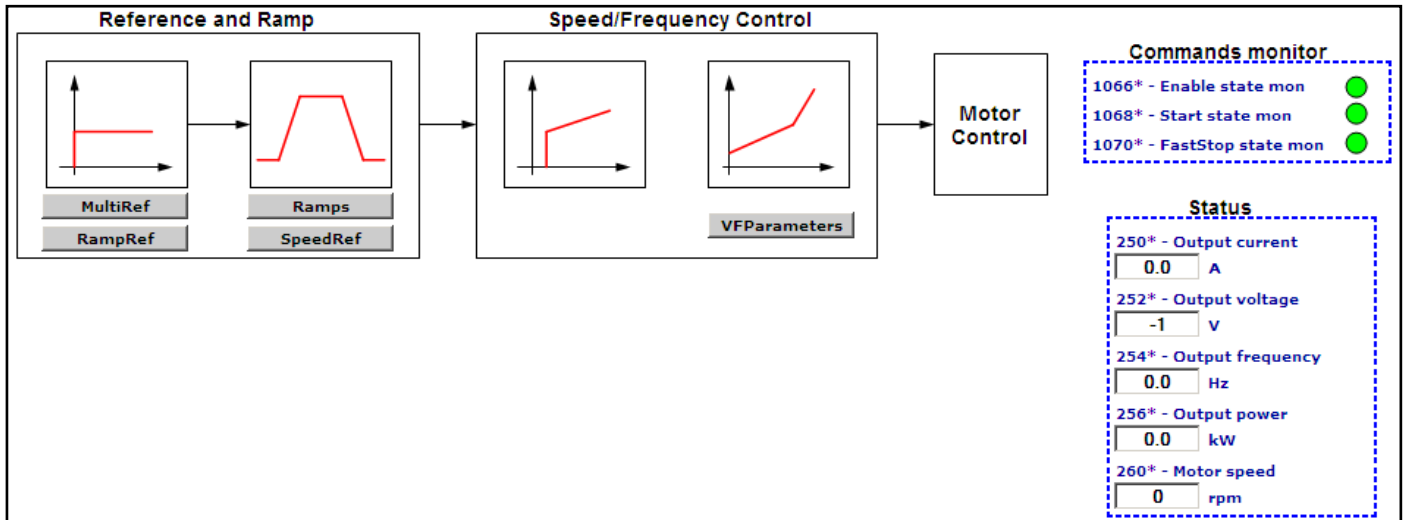

Menu	PAR	Description	UM	Type	FB BIT	Def	Min	Max	Acc	Mod
1.1	250	Output current	A	FLOAT	16/32	0.0	0.0	0.0	R	VS

The drive output current is displayed.

Menu	PAR	Description	UM	Type	FB BIT	Def	Min	Max	Acc	Mod
1.2	252	Output voltage	V	FLOAT	16/32	0.0	0.0	0.0	R	VS

The drive line voltage output is displayed.

Menu	PAR	Description	UM	Type	FB BIT	Def	Min	Max	Acc	Mod
1.3	254	Output frequency	Hz	FLOAT	16/32	0	0	0	R	VS

The drive output frequency is displayed.

Menu	PAR	Description	UM	Type	FB BIT	Def	Min	Max	Acc	Mod
1.4	256	Output power	kW	FLOAT	16/32	0.0	0.0	0.0	R	VS

Displays the drive output power.

Menu	PAR	Description	UM	Type	FB BIT	Def	Min	Max	Acc	Mod
1.5	628	Ramp setpoint	rpm	INT16	16/32	0	0	0	R	VS

The ramp reference is displayed. This is the speed value the drive must reach at the end of the ramp.

Menu	PAR	Description	UM	Type	FB BIT	Def	Min	Max	Acc	Mod
1.6	664	Speed setpoint	rpm	INT16	16/32	0	0	0	R	VS

The speed reference is displayed. This is the value measured at the output of the speed reference circuit.

Menu	PAR	Description	UM	Type	FB BIT	Def	Min	Max	Acc	Mod
1.7	260	Motor speed	rpm	INT16	16/32	0	0	0	R	VS

The actual output speed of the motor is displayed (in Flux vector OL/V/f control = speed estimated by the drive).

Menu	PAR	Description	UM	Type	FB BIT	Def	Min	Max	Acc	Mod
1.8	270	DC link voltage	V	FLOAT	16/32	0.0	0.0	0.0	ER	VS

The direct voltage of the intermediate circuit capacitors is displayed (DC-Bus).

Menu	PAR	Description	UM	Type	FB BIT	Def	Min	Max	Acc	Mod
1.9	272	Heatsink temperature	degC	INT16	16	0	0	0	ER	VS
The temperature measured on the drive heatsink is displayed.										
1.10	290	Motor temperature	degC	FLOAT		0.0	0.0	0.0	ER	VS
The motor temperature measured by the PT100 probes. The temperature can only be measured correctly if just one temperature sensor is connected.										
1.11	280	Torque current ref	A	FLOAT	16/32	0.0	0.0	0.0	ER	_S
The current reference used for torque control is displayed (in the Flux vector OL mode).										
1.12	282	Magnet current ref	A	FLOAT	16/32	0.0	0.0	0.0	ER	_S
The magnetizing current reference is displayed (in the Flux vector OL mode).										
1.13	284	Torque current	A	FLOAT	16/32	0.0	0.0	0.0	ER	VS
The actual torque current value is displayed.										
1.14	286	Magnet current	A	FLOAT	16/32	0.0	0.0	0.0	ER	VS
The actual magnetizing current value is displayed.										
1.15	3212	Motor overload accum	perc	UINT16	16/32	0	0	100	ER	VS
The motor overload level is displayed (100% = alarm threshold).										
1.16	368	Drive overload accum	perc	UINT16	16/32	0	0	100	ER	VS
The drive overload level is displayed. An instantaneous overload of 180% of the drive rated current is allowed for 0.5s. The thermal image I ² t adjusts the drive output current thresholds. During normal operation, the instantaneous output current value can reach 180% of the drive rated current. After 0.5s at 180%, the output current threshold is reduced to 150%. When the overload level par. 368 Drive overload accum reaches 100%, the output current threshold is reduced to 100% of the rated current, and stays at that value until the I ² t integrator cycle is complete. At this point the 180% instantaneous overload is re-enabled.										
1.17	3260	Bres overload accum	perc	UINT16	16/32	0	0	100	ER	VS
The braking resistor overload limit is displayed (100% = alarm threshold).										
1.18	1066	Enable state mon		BIT	16	0	0	1	R	VS
The drive Enable command status is displayed. Voltage must be present on terminal 7. The FR Forwardstart command is needed to start the inverter.										
0 Disabled drive disabled										
1 Enabled drive enabled										
1.19	1068	Start state mon		BIT	16	0	0	1	R	VS
The drive Start command status is displayed.										

Menu	PAR	Description	UM	Type	FB BIT	Def	Min	Max	Acc	Mod
1.20	1070	FastStop state mon		BIT	16	0	0	1	R	VS

The drive **FastStop** command status is displayed.

Menu	PAR	Description	UM	Type	FB BIT	Def	Min	Max	Acc	Mod
1.21	1100	Digital input mon		UINT16	16	0	0	0	R	VS

The status of the digital inputs on the drive is displayed. It can also be read via a serial line or fieldbus. The data are contained in a word, where each bit is 1 if voltage is supplied to the corresponding input terminal.

1 Input enabled.

0 Input disabled.

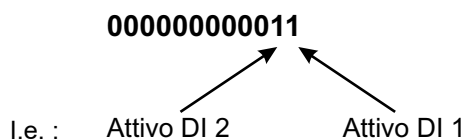

Menu	PAR	Description	UM	Type	FB BIT	Def	Min	Max	Acc	Mod
1.22	1300	Digital output mon		UINT16		0	0	0	R	VS

The status of the digital outputs on the drive is displayed. It can also be read via a serial line or fieldbus. The data are contained in a word, where each bit is 1 if voltage is supplied to the corresponding input terminal.

1 Output enabled.

0 Output disabled.

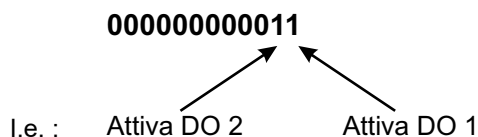

Menu	PAR	Description	UM	Type	FB BIT	Def	Min	Max	Acc	Mod
1.23	1200	Digital input X mon		UINT16	16	0	0	0	R	VS

The status of the digital inputs of the expansion card is displayed. It can also be read via a serial line or fieldbus. The data are contained in a word, where each bit is 1 if voltage is supplied to the corresponding input terminal. This parameter displays the state of the 16 external inputs. The 14 less significant bits are displayed from the keypad.

1 Input enabled.

0 Input disabled.

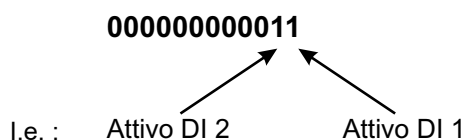

Menu	PAR	Description	UM	Type	FB BIT	Def	Min	Max	Acc	Mod
1.24	1400	Digital output X mon		UINT16		0	0	0	R	VS

The status of the digital outputs of the expansion card is displayed. It can also be read via a serial line or fieldbus. The data are contained in a word, where each bit is 1 if voltage is supplied to the corresponding input terminal.

1 Output enabled.

0 Output disabled.

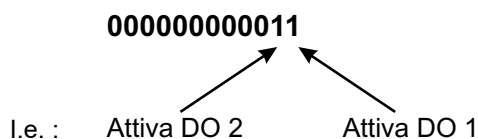

2 – DRIVE INFO

This menu displays the information for identifying and configuring the drive.

Menu	PAR	Description	UM	Type	FB BIT	Def	Min	Max	Acc	Mod
2.1	482	Drive size		UINT16		0	0	0	R	

The drive size identification code is displayed.

Size code	Size text	Family code	Family text
1	0.75/1.5 kW	1	380V..480V
2	1.5/2.2 kW	1	380V..480V
3	2.2/3.0 kW	1	380V..480V
4	3.0/4.0 kW	1	380V..480V
5	4.0/5.5 kW	1	380V..480V
6	5.5/7.5 kW	1	380V..480V
7	7.5/11.0 kW	1	380V..480V
8	11.0/15.0 kW	1	380V..480V
9	15.0/18.5 kW	1	380V..480V
10	18.5/22.0 kW	1	380V..480V
11	22.0/30.0 kW	1	380V..480V
12	30.0/37.0 kW	1	380V..480V
13	37.0/45.0 kW	1	380V..480V
14	45.0/55.0 kW	1	380V..480V
15	55.0/75.0 kW	1	380V..480V
16	75.0/90.0 kW	1	380V..480V
17	90.0/110.0 kW	1	380V..480V
18	110.0/132.0 kW	1	380V..480V
19	132.0/160.0 kW	1	380V..480V
19	132.0/160.0 kW	1	380V..480V
20	160.0/200.0 kW	1	380V..480V
21	200.0/250.0 kW	1	380V..480V
22	250.0/315.0 kW	1	380V..480V
23	315.0/355.0 kW	1	380V..480V
24	355.0/400.0 kW	1	380V..480V
25	400.0/500.0 kW	1	380V..480V
26	500.0/630.0 kW	1	380V..480V
27	630.0/710.0 kW	1	380V..480V
28	710.0/800.0 kW	1	380V..480V
29	0.9/1.0 MW	1	380V..480V
30	1.0/1.2 MW	1	380V..480V

Menu	PAR	Description	UM	Type	FB BIT	Def	Min	Max	Acc	Mod
2.2	484	Drive family		ENUM		No Power	0	0	RS	VS

The available mains voltage is displayed (e.g. 400V). The undervoltage alarm refers to this voltage value.

The condition No power occurs when the regulation board has just left from production and has never been configured for any power. The configuration adjustment for a given power is achieved by linking it to a power board and running a **Save parameters**.

- 0 No Power
- 1 380V...480V
- 2 500V...575V
- 3 690V
- 4 230V

Menu	PAR	Description	UM	Type	FB BIT	Def	Min	Max	Acc	Mod
2.3	486	Drive region		ENUM		EU	0	1	R	VS

The geographical area (Europe or USA) is displayed. The factory settings for the power supply voltage and frequency used by the drive are defined accordingly.

0 EU (400V / 50Hz)

1 USA (460 / 60 Hz)

Menu	PAR	Description	UM	Type	FB BIT	Def	Min	Max	Acc	Mod
2.4	488	Drive cont current	A	FLOAT		CALCF	0.0	0.0	RZS	VS

The current that the drive can deliver continuously according to size, supply voltage and programmed switching frequency is displayed.

Menu	PAR	Description	UM	Type	FB BIT	Def	Min	Max	Acc	Mod
2.5	490	Firmware ver.rel		UINT16		0	0	0	R	VS

The version number and release number of the drive firmware are displayed. On the keypad these are displayed in the version.release format. The parameter reading from the serial communication device or fieldbus returns the version in the high byte and the release in the low byte.

Menu	PAR	Description	UM	Type	FB BIT	Def	Min	Max	Acc	Mod
2.6	496	Firmware type		UINT16		0	0	0	R	VS

The type of firmware installed in the drive is displayed.

Menu	PAR	Description	UM	Type	FB BIT	Def	Min	Max	Acc	Mod
2.7	504	Application ver.rel		UINT16		0	0	0	ER	VS

The version and release number of the application used in the drive are displayed. On the keypad these are displayed in version.release format. When the parameter is read via serial line or fieldbus the version is returned in the high byte and the release in the low byte.

Menu	PAR	Description	UM	Type	FB BIT	Def	Min	Max	Acc	Mod
2.8	506	Application type		UINT16		0	0	0	ER	VS

The type of application currently used by the drive is displayed.

Menu	PAR	Description	UM	Type	FB BIT	Def	Min	Max	Acc	Mod
2.9	508	Application subver		UINT16		0	0	0	ER	VS

The Revision Index of the application currently used by the drive is displayed.

Menu	PAR	Description	UM	Type	FB BIT	Def	Min	Max	Acc	Mod
2.10	518	Actual date time		UINT32		0	0	0	R	VS

The current date and time are displayed in dd/mm/yyy hh/min format.

Menu	PAR	Description	UM	Type	FB BIT	Def	Min	Max	Acc	Mod
2.11	510	Time drive power on	h.min	UINT32		0	0	0	ER	VS

The total time for which the drive has been powered is displayed.

Menu	PAR	Description	UM	Type	FB BIT	Def	Min	Max	Acc	Mod
2.12	512	Time drive enable	h.min	UINT32		0	0	0	ER	VS

The time for which the enable hardware contact on the drive has been connected is displayed.

Menu	PAR	Description	UM	Type	FB BIT	Def	Min	Max	Acc	Mod
2.13	514	Number power up		UINT16		0	0	0	ER	VS

The number of times the drive has been powered on is displayed.

Menu	PAR	Description	UM	Type	FB BIT	Def	Min	Max	Acc	Mod
2.14	516	Time fan on	h.min	UINT32		0	0	0	ER	VS

The total operating time of the drive fan is displayed.

Menu	PAR	Description	UM	Type	FB BIT	Def	Min	Max	Acc	Mod
2.15	530	Power file ver.rel		UINT16		0	0	0	R	VS

The version number and release number of the drive power card are displayed.

Menu	PAR	Description	UM	Type	FB BIT	Def	Min	Max	Acc	Mod
2.16	530	Slot 1 card type		ENUM		None	0	0	R	VS
2.17	532	Slot 2 card type		ENUM		None	0	0	R	VS
2.18	534	Slot 3 card type		ENUM		None	0	0	R	VS

The type of expansion card installed in the relative slot of the drive is displayed.

- 0** None
- 769** I/O 1
- 1793** I/O 2
- 2305** I/O 3
- 3329** I/O 4
- 7681** I/O 8 (EXP-IO-SENS-1000-ADV)
- 5633** I/O 6 (EXP-IO-SENS-100-ADV)
- 6401** I/O 7 (EXP-IO-D5R8-ADV)
- 4** Can/Dnet
- 260** Profibus
- 516** RTE
- 255** Unknown

3 – STARTUP WIZARD

The startup wizard menu suggests a procedure for commissioning the drive quickly with a reduced number of settings. Advanced customization requires the use of the single parameters relating to the specific performance levels. See the procedure described in the **Startup wizard** chapter in Quick Start ADV200 SP -QS manual.

4 – DRIVE CONFIG

Menu	PAR	Description	UM	Type	FB BIT	Def	Min	Max	Acc	Mod
4.1	550	Save parameters		BIT		0	0	1	RW	VS

Any changes to parameter values immediately affect drive operations, but are not automatically saved in the permanent memory.

The “Save Parameters” command is used to save current parameter values in the permanent memory.

Any changes that are not saved will be lost when the drive is switched off.

To save parameters follow the procedure described in **STEP 6** of the **Startup wizard**.

Menu	PAR	Description	UM	Type	FB BIT	Def	Min	Max	Acc	Mod
4.2	552	Regulation mode		ENUM		V/f control	0	2	RWZ	VS

The ADV200 is capable of operating with different control modes:

- 0 V/f control
- 1 Flux vector OL
- 2 Autotune

The open loop **V/f (V/f control)** mode is the simplest type of asynchronous motor control, as the only parameters required are the rated voltage, current and frequency of the motor.

The open loop V/F control mode is factory-set and does not require any speed feedback. The natural variation in speed generated by machine load induction (slippage) can be compensated using **Slip comp** and **Slip comp filter**.

In V/f mode a single drive can be used to control several asynchronous motors, even of different sizes, connected in parallel, provided the sum of the currents of the single motors is less than the drive rated current. If using several motors connected in parallel, be sure to provide adequate thermal protection for each single motor.

With the **sensorless vector control (Flux vector OL)** mode, high speed and torque precision can be achieved at low motor rpm. The drive has a powerful algorithm that uses a self-tuning procedure to obtain all the electric measurements of the motor. This allows the speed and position of the motor shaft to be estimated, enabling operation similar to that of a drive with feedback, both in terms of the response in torque to load variations, and of the regularity of rotation even at very low rpm.

If the **Startup wizard** procedure is not used, self-tuning of the motor parameters is possible in the **self-tuning mode (Autotune)**. To execute the command the hardware enabling contact between terminals 7 and S2 must be opened. Then set the **Regulation Mode** parameter to **Autotune**. If not already in Local mode, press the Local key (the **LOC** LED lights up) and close the hardware enabling contact (terminals 7 and S3). Self-tuning can now be enabled (refer to parameters **2022** or **2224**). At the end of the self-tuning procedure, open the contact between terminals 7 and S3 again and restore the parameters that were changed.

This procedure must be used for both self-tuning with the engine standing still and with the motor turning.

Menu	PAR	Description	UM	Type	FB BIT	Def	Min	Max	Acc	Mod
4.3	554	Access mode		ENUM		Easy	0	1	RW	VS

With this parameter you can restrict access to advanced configuration.

- 0 Easy
- 1 Expert

The **Easy** mode gives access to a list of parameters that can be used for rapid drive commissioning. This type of configuration is suitable for the majority of applications.

Setting the parameter to **Expert** gives access to all the parameters in the firmware. This mode allows an extremely high level of customization to be achieved in order to exploit the potential of the ADV200 to the full.

Menu	PAR	Description	UM	Type	FB BIT	Def	Min	Max	Acc	Mod
4.4	556	Control mode select		ENUM		Ramp	0	2	ERWZ	_S

Selection of the drive control mode.

- 0 Torque
- 1 Speed
- 2 Ramp

In **torque control (0 - Torque)** the reference and load of the motor determine its speed and direction of rotation. Symmetrical torque limits can be set, for each direction of rotation and for motor/generator operation.

In **speed control (1 - Speed)** the reference arrives straight after the ramp circuit, enabling an extremely rapid response to signal variations. This is ideal for applications that require a highly dynamic response. This type of control is available in the **Flux vector OL** control mode. In this mode the **Ramp** function is not used to generate the drive speed reference so it can be used in stand-alone mode.

In **control with ramp (2 - Ramp)** the speed reference is applied to the input of the “**Ramp**” block and is produced by the “**Ramp ref**” block. This allows setting of both the acceleration/deceleration times and the ramp time (linear or S-shaped with customizable jerks). This type of control is available in all control.

Menu	PAR	Description	UM	Type	FB BIT	Def	Min	Max	Acc	Mod
4.5	558	Application select		ENUM		None	0	2	ERWZ	VS

Selection of which IEC 61131-3-compliant application.

- 0 None
- 1 Application 1 (**Solar pump**, see menu 27)
- 2 Application 2

The drive is supplied already incorporating a number of applications developed in the IEC 61331-3 environment. To use these, set the desired application, run **Save parameters**, switch the drive off and then on again.

NOTE!

The **Load Default** command (par. 580) does not modify this parameter

Menu	PAR	Description	UM	Type	FB BIT	Def	Min	Max	Acc	Mod
4.6	560	Mains voltage		ENUM		400 V	SIZE	SIZE	ERWZS	VS

Setting of the available mains voltage value in Volts. Detection of the undervoltage alarm refers to this value.

- 0 None
- 1 230 V
- 2 380 V
- 3 400 V
- 4 415 V
- 5 440 V
- 6 460 V
- 7 480 V
- 8 500 V
- 9 575 V
- 10 690 V

Menu	PAR	Description	UM	Type	FB BIT	Def	Min	Max	Acc	Mod
4.7	586	DC supply		ENUM		None	0	7	ERWZSVS	

Selection of the voltage applied to the DC link if the drive is powered by an AC/DC power supply unit, whether normal or regenerative (e.g. AFE200). If a value of other than “None” is selected, parameters that depend on parameter 560 **Mains voltage** are calculated on the basis of the voltage shown in the table below, while the value of parameter 560 Tensione di rete is set automatically.

If “None” is selected, these parameters are calculated according to the value of parameter 560 **Mains voltage**.

	DC power supply	Drive family 380V..480V Mains voltage
0	None	Use P560
1	540 V (380-480V)	400 V
2	650 V (380-480V)	460 V
3	750 V (380-480V)	460 V
10	675 V (690V)	N/A
11	810 V (690V)	N/A
12	935 V (690V)	N/A
13	1120 V (690V)	N/A

Menu	PAR	Description	UM	Type	FB BIT	Def	Min	Max	Acc	Mod
4.8	450	Undervoltage	V	FLOAT		CALCF	CALCF	CALCF		ERWZSVS

Setting of the drive minimum operating voltage. The maximum and minimum default values are calculated automatically by the drive according to the value set in parameter 560 **Mains voltage**, as shown in the table below.

Table of undervoltage limits

	Mains voltage	Def	Min	Max
0	None	(Vdc)	(Vdc)	(Vdc)
1	230 V	225	200	282
2	380 V	372	330	466
3	400 V	392	330	490
4	415 V	407	360	509
5	440 V	431	382	539
6	460 V	451	400	564
7	480 V	470	417	588
8	500 V	490	434	613
9	575 V	563	500	705
10	690 V	676	600	846

Menu	PAR	Description	UM	Type	FB BIT	Def	Min	Max	Acc	Mod
4.9	562	Switching frequency		ENUM		SIZE	SIZE	SIZE		ERWS VS

Setting of the switching frequency value in kHz. The maximum value that can be set depends on the size of the drive. See ADV200 SP Quick Start manual.

- 0 1 kHz
- 1 2 kHz
- 2 4 kHz
- 3 6 kHz
- 4 8 kHz
- 5 10 kHz
- 6 12 kHz
- 7 16 kHz

Menu	PAR	Description	UM	Type	FB BIT	Def	Min	Max	Acc	Mod
4.10	564	Ambient temperature		ENUM		40 degC	0	1		ERWZ VS

Setting of the ambient temperature value. This parameter is used to set the output current derating factor (1% for every °C above 40°C).

- 0 40 degC The inverter is capable of delivering direct current continuously with ambient temperatures of up to 40°C.
- 1 50 degC The inverter is capable of delivering direct current continuously with ambient temperatures of up to 50°C.

If the value is set to 1 the drive output current will be 10% less than the rated current at 40°C.

Menu	PAR	Description	UM	Type	FB BIT	Def	Min	Max	Acc	Mod
4.11	566	Drive overload mode		ENUM		Light duty	1	2	ERWZ	VS

Setting of the overload that can be supplied by the drive, depending on the application.

- 1 Heavy duty
- 2 Light duty

Set **Heavy duty** when a large overload is requested: the drive can supply 180% of the rated current for 0.5 seconds and 150% for 1 minute every 5 minutes.

Select **Light duty** to enable the drive to deliver a current of 110% of the rated current for 1 minute every 5 minutes.

Menu	PAR	Description	UM	Type	FB BIT	Def	Min	Max	Acc	Mod
4.12	568	Switching freq mode		ENUM		Costant	0	1	ERWZS	VS

Setting of the switching frequency operating mode when drive overload is set in Heavy duty. The factory switching frequency setting is 4 kHz for motors between 2.2 kW and 37 kW (the factory switching frequency setting for smaller drives is 8kHz); this value may result in increased noise. Setting a higher switching frequency will increase drive losses and thus increase the heatsink temperature, but it will also reduce noise. To combine the advantages of both settings, with the ADV drive the heatsink temperature can be controlled by reducing the switching frequency if it increases.

- 0 Costant
- 1 Variable

If set to **Costant** the switching frequency is fixed and is set using the **Switching frequency** parameter, according to the size of the drive. If the selected switching frequency value is higher than the default value, the output current of the drive is derated.

If set to **Variable** the switching frequency is set to 8kHz and controlled by the temperature of the drive heat-sink and by the output frequency. If the heatsink temperature exceeds a set threshold (which depends on the size of the drive) or falls to below $5\text{Hz} \pm 1\text{Hz}$, the switching frequency is automatically reduced to 4kHz, to prevent derating of the output current. The switching frequency is reduced in a single step. **With this setting the switching frequency value selected in the Switching frequency parameter is ineffective.**

Menu	PAR	Description	UM	Type	FB BIT	Def	Min	Max	Acc	Mod
4.13	570	Password		UINT32		0	0	99999	ERW	VS

You can enter a **password** to protect the parameters from unauthorized tampering: the password can consist of a combination of a maximum of any 5 figures that can be selected by the user. All parameters are locked, except this one and **Save parameters**.

After entering the password, press the E key once to enter it into the memory and again to enable it (= Enabled is displayed to indicate that the password is enabled).

So that the password remains valid even after switching the unit off and then switching it back on, save it using the **Save parameters** command.

When the password is enabled any attempts to modify a parameter are blocked and the **Password enabled** message is displayed.

To disable the password, enter the **Password** parameter (572) in the **DRIVE CONFIG** menu.

Check that the password is enabled (**Enabled**), press **E** and enter the combination of figures that make up the password.

Press E again. A message is displayed telling you the password is no longer enabled (**Disabled**).

To make sure the password continues to be disabled even after switching the unit off and then switching it back on, save this configuration using the **Save parameters** command.

When an incorrect password is entered, the Password wrong message is displayed.

Menu	PAR	Description	UM	Type	FB BIT	Def	Min	Max	Acc	Mod
4.14	572	Application key		UINT32	0	0	4294967295	ERW	VS	

This parameter can be used to enter the key for enabling the PLC application.

You may need to enter a key to definitively enable some PLC applications. Please contact WEG for details

about which PLC applications require the key.

If executing an application that envisages a key verification and the key is incorrect, enabling is forced for 200 hours (time drive enabled).

In this phase a message is displayed informing you that the period of forced enabling time is about to expire. At the first power-on after the 200 hours an alarm is generated and the application does not start.

Please contact WEG for the numerical value of the key.

Menu	PAR	Description	UM	Type	FB BIT	Def	Min	Max	Acc	Mod
4.15	574	Startup display		INT16		-1	-1	20000	ERW	VS

This is used to set the parameter that will be displayed automatically at drive power-on. Entering the value -1 (default), the function is disabled and the main menu is displayed at power-on.

Menu	PAR	Description	UM	Type	FB BIT	Def	Min	Max	Acc	Mod
4.16	576	Display backlight		BIT		0	0	1	ERW	VS

Enabling of the backlight on the drive display.

If set to **0** the display backlight will go off when the drive has been on for three minutes.

If set to **1** the backlight will stay on for as long as the drive is powered.

Menu	PAR	Description	UM	Type	FB BIT	Def	Min	Max	Acc	Mod
4.17	578	Language select		ENUM		English	0	9	RWZ	VS

Setting of the drive programming language.

- 0 English
- 1 Italian
- 2 French
- 3 German
- 4 Spanish
- 5 Polish
- 6 Romanian
- 7 Russian
- 8 Turkish
- 9 Portuguese

Note !

The **Load Default** command (par. 580) does not modify this parameter.

Menu	PAR	Description	UM	Type	FB BIT	Def	Min	Max	Acc	Mod
4.18	580	Load default		BIT		0	0	1	RWZ	VS

Transfers the standard factory settings to the drive memory ("Def" column in the parameters table).

Menu	PAR	Description	UM	Type	FB BIT	Def	Min	Max	Acc	Mod
4.19	590	Save par to keypad		BIT		0	0	1	RW	VS

Transfers the parameters currently stored in the drive and saves them in the keypad memory (See ADV200 SP Quick Start manual, chapter 6.8).

Menu	PAR	Description	UM	Type	FB BIT	Def	Min	Max	Acc	Mod
4.20	592	Load par from keypad		BIT		0	0	1	RWZ	VS

Transfers the parameters from the keypad memory to the drive (See ADV200 Quick Start manual, chapter 6.9).

Menu	PAR	Description	UM	Type	FB BIT	Def	Min	Max	Acc	Mod
4.21	594	Keypad memory select		UINT16		1	1	5	ERW	VS

Selection of the area of the keypad memory to which to transfer and save the parameters stored in the drive.

5 – REFERENCES

ADV drives are provided with a speed regulation circuit, which can be adapted to suit the various applications. In the standard version, the regulator has PI behaviour and the regulator parameters are the same for the entire field of regulation.

Different sources can be used for the speed and torque references, depending on how the **554 Control mode select** parameter is set.

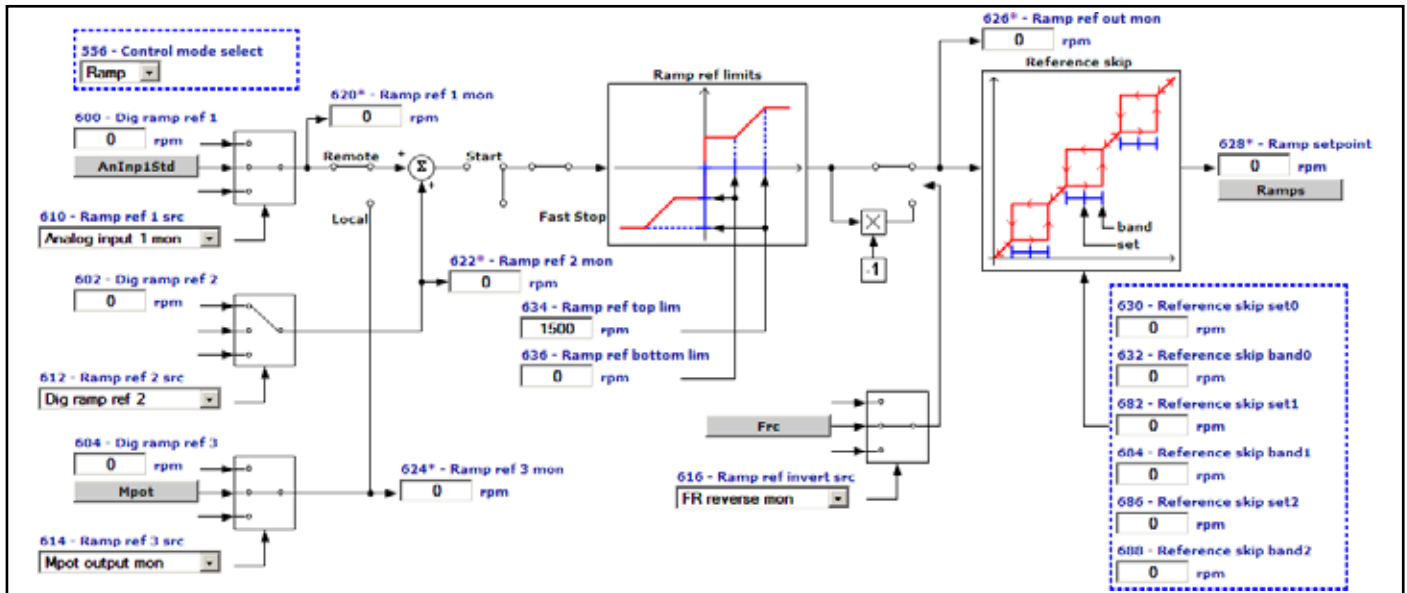

Menu	PAR	Description	UM	Type	FB BIT	Def	Min	Max	Acc	Mod
5.1	600	Dig ramp ref 1	FF	INT16	16/32	0	CALCI	CALCI	RW	VS

Setting of the digital ramp reference. The speed that the drive must reach after completing the acceleration phase is set with the ramp reference. Variations in the ramp reference are made with the selected ramp times. The size of the ramp reference determines the motor speed value. The sign determines the direction of rotation. The **Ramp ref** parameter also refers to a minimum speed, if set. When the “**Motor potentiometer**” or “**Multispeed**” functions are selected the relative references are used. This reference can only be used in the **Remote** mode.

The overall ramp reference is the result of the sum of the values with the **Ramp ref 1** and **Ramp ref 2** sign.

Example 1: **Ramp ref 1** = + 500 rpm **Ramp ref 2** = + 300 rpm
Ramp ref = 500 rpm + 300 rpm = 800 rpm

Example 2: **Ramp ref 1** = + 400 rpm **Ramp ref 2** = - 600 rpm
Ramp ref = 400 rpm – 600 rpm = - 200 rpm

Menu	PAR	Description	UM	Type	FB BIT	Def	Min	Max	Acc	Mod
5.2	602	Dig ramp ref 2	FF	INT16	16/32	0	CALCI	CALCI	ERW	VS

Setting of the digital ramp reference. The speed that the drive must reach after completing the acceleration phase is set with the ramp reference. Variations in the ramp reference are made with the selected ramp times. The size of the ramp reference determines the motor speed value. The sign determines the direction of rotation. The **Ramp ref** parameter also refers to a minimum speed, if set. When the “**Motor potentiometer**” or “**Multispeed**” functions are selected the relative references are used.

In **Remote** mode the overall ramp reference is the result of the sum of the values with the **Ramp ref 1** and **Ramp ref 2** sign.

Example 1: **Ramp ref 1** = + 500 rpm **Ramp ref 2** = + 300 rpm

Ramp ref = 500 rpm + 300 rpm = 800 rpm

Example 2: **Ramp ref 1** = + 400 rpm **Ramp ref 2** = - 600 rpm

Ramp ref = 400 rpm – 600 rpm = - 200 rpm

In **Local** mode the overall ramp reference is the result of the sum of the values with the **Ramp ref 3** and **Ramp ref 2** sign.

Example 1: **Ramp ref 3** = + 500 rpm **Ramp ref 2** = + 300 rpm

Ramp ref = 500 rpm + 300 rpm = 800 rpm

Example 2: **Ramp ref 3** = + 400 rpm **Ramp ref 2** = - 600 rpm

Ramp ref = 400 rpm – 600 rpm = - 200 rpm

Menu	PAR	Description	UM	Type	FB BIT	Def	Min	Max	Acc	Mod
5.3	604	Dig ramp ref 3	FF	INT16	16/32	0	CALCI	CALCI	ERW	VS

Setting of the digital ramp reference. The speed that the drive must reach after completing the acceleration phase is set with the ramp reference. Variations in the ramp reference are made with the selected ramp times. The size of the ramp reference determines the motor speed value. The sign determines the direction of rotation. The **Ramp ref** parameter also refers to a minimum speed, if set. When the “**Motor potentiometer**” or “**Multispeed**” functions are selected the relative references are used. This reference can only be used in the **Local** mode.

The overall ramp reference is the result of the sum of the values with the **Ramp ref 3** and **Ramp ref 2** sign.

Example 1: **Ramp ref 3** = + 500 rpm **Ramp ref 2** = + 300 rpm

Ramp ref = 500 rpm + 300 rpm = 800 rpm

Example 2: **Ramp ref 3** = + 400 rpm **Ramp ref 2** = - 600 rpm

Ramp ref = 400 rpm – 600 rpm = - 200 rpm

Menu	PAR	Description	UM	Type	FB BIT	Def	Min	Max	Acc	Mod
5.4	610	Ramp ref 1 src		LINK	16/32	1500	0	16384	RW	VS
5.5	612	Ramp ref 2 src		LINK	16/32	602	0	16384	ERW	VS
5.6	614	Ramp ref 3 src		LINK	16/32	894	0	16384	ERW	VS

Selection of the origin (source) of the reference signals on the input of the ramp function block, that defines the main drive speed. The ramp reference values can be selected from among those listed in the “**L_ML-TREF**” selection list.

When assigning the reference via terminals, signals with ±10V, 0 ...10V, 0... 20 mA and 4 ... 20 mA can be used.

Menu	PAR	Description	UM	Type	FB BIT	Def	Min	Max	Acc	Mod
5.7	616	Ramp ref invert src		LINK	16	1050	0	16384	ERW	VS

Selection of the origin (source) of the signal that inverts the ramp reference output from the “Ramp ref” block. The signal that can be used for this function can be selected from among those listed in the “**L_DIGSEL2**” selection list.

Menu	PAR	Description	UM	Type	FB BIT	Def	Min	Max	Acc	Mod
5.8	620	Ramp ref 1 mon	FF	INT16		0	0	0	R	VS
5.9	622	Ramp ref 2 mon	FF	INT16		0	0	0	ER	VS
5.10	624	Ramp ref 3 mon	FF	INT16		0	0	0	ER	VS

The value of the relative ramp reference on the output of the relative function block is displayed.

Menu	PAR	Description	UM	Type	FB BIT	Def	Min	Max	Acc	Mod
5.11	634	Ramp ref top lim	FF	INT32		0	0	CALCI	ERWZ	VS

It defines the maximum value of the output of the ramp reference block, regardless of the signal that is present. The ramp reference follows the reference signal from the value set in parameter PAR 636 **Ramp ref bottom lim** up to the value set with this parameter, after which the motor speed remains constant. The limit is valid for both directions of rotation.

Menu	PAR	Description	UM	Type	FB BIT	Def	Min	Max	Acc	Mod
5.12	636	Ramp ref bottom lim	FF	INT32		0	0	CALCI	ERWZ	VS

It defines the minimum value of the output of the ramp reference block, regardless of the signal that is present. The ramp block output remains at the value set with this parameter until the analog signal exceeds this threshold: the ramp output value then starts to follow the reference up to the value set in parameter PAR 634 **Ramp ref top lim**. The limit is valid for both directions of rotation.

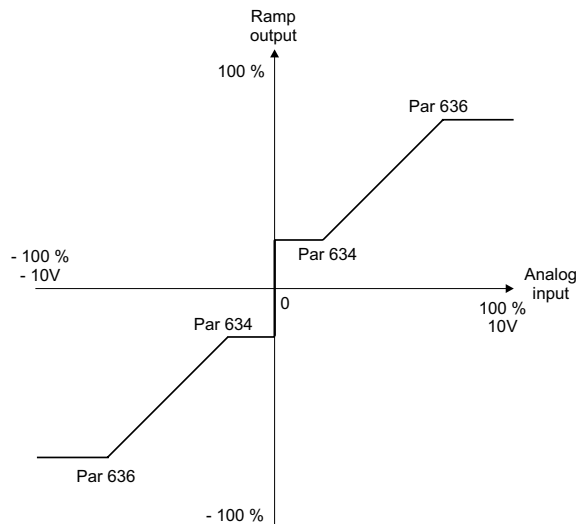

Menu	PAR	Description	UM	Type	FB BIT	Def	Min	Max	Acc	Mod
5.13	630	Reference skip set0	rpm	INT16		0	0	CALCI	ERW	VS
5.15	682	Reference skip set1	rpm	INT16		0	0	CALCI	RW	VS
5.17	686	Reference skip set2	rpm	INT16		0	0	CALCI	RW	VS

Setting of the prohibited speed threshold at which the drive cannot operate.

Menu	PAR	Description	UM	Type	FB BIT	Def	Min	Max	Acc	Mod
5.14	632	Reference skip band0	rpm	INT16		0	0	CALCI	ERW	VS
5.16	684	Reference skip band1	rpm	INT16		0	0	CALCI	RW	VS
5.18	688	Reference skip band2	rpm	INT16		0	0	CALCI	RW	VS

Setting of the prohibited bandwidth.

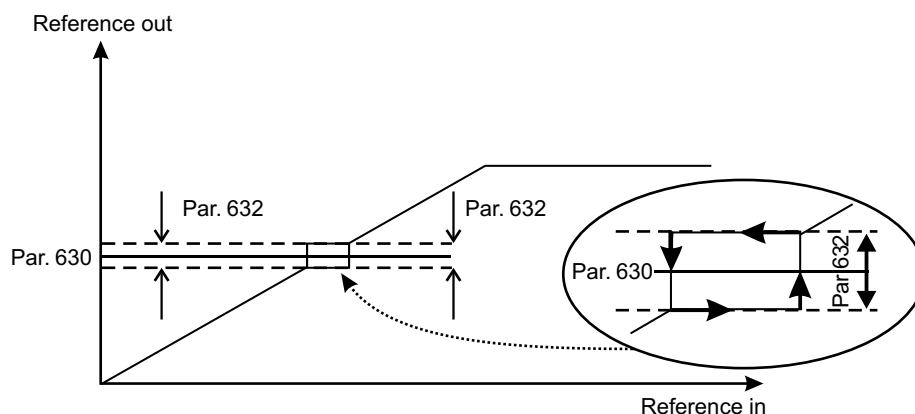

Example:

A) Increase in the reference by values of less than **Par. 630**

Par. 630 = 300 rpm (prohibited speed threshold)

Par. 632 = 10 rpm (thus prohibited band: 290rpm..310rpm)

Set speed reference = 295 rpmHz

Output speed = 290 rpm

Set speed reference = 305 rpm

Output speed = 290 rpm

B) Decrease in the reference by values above *Par. 630*

Par.630 = 300 rpm (prohibited speed threshold)

Par.632 = 10 rpm (thus tolerance band: 290 rpm...310 rpm)

Set speed reference = 305 rpm

Output frequency = 310 rpm

Set speed reference = 295 rpm

Output frequency = 310 rpm

The user can thus set any reference value, but if the set value is within the prohibited range, the drive automatically maintains the speed outside the limits defined by the tolerance band.

During ramp phases the prohibited speed is passed freely and there are no points of discontinuity in the generation of the output frequency.

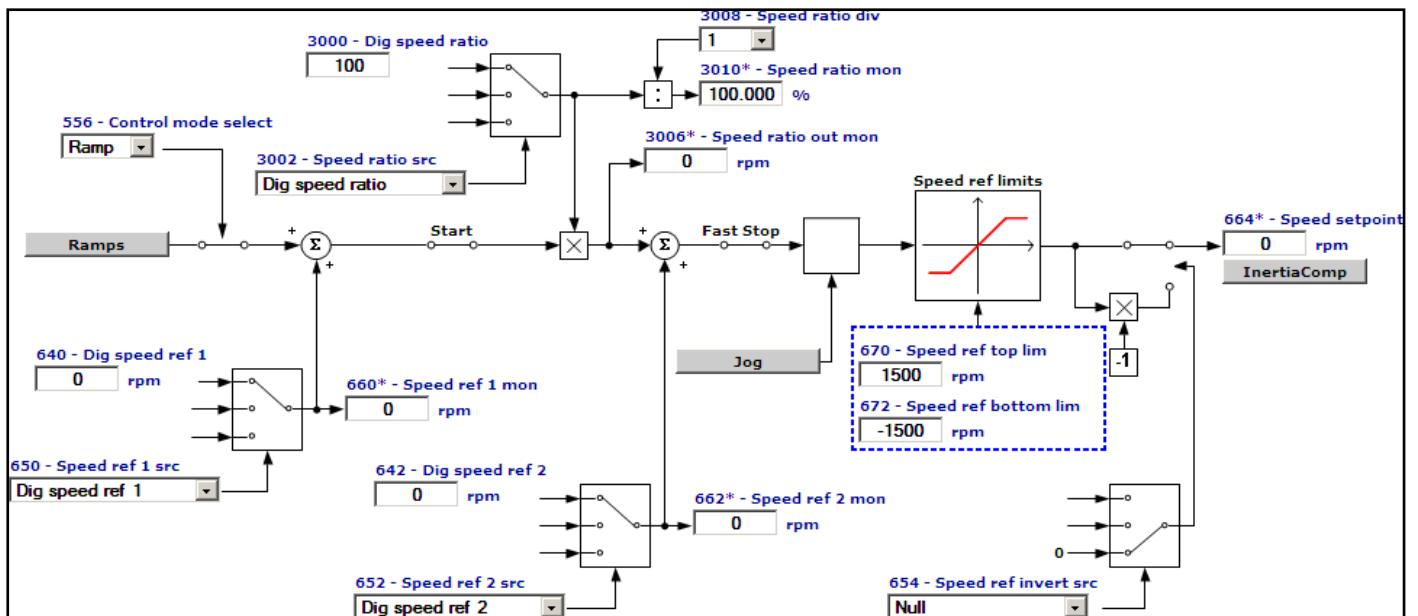

The speed reference supplies the desired speed to the drive, which directly follows the reference pattern. This only happens when the available torque is sufficient. In this case the drive functions at its current limit, until reaching the set speed. The speed reference value determines the motor speed value. The sign determines the direction of rotation.

Menu	PAR	Description	UM	Type	FB BIT	Def	Min	Max	Acc	Mod
5.19	640	Dig speed ref 1	FF	INT16	16/32	0	CALCI	CALCI	ERW	VS
5.20	642	Dig speed ref 2	FF	INT16	16/32	0	CALCI	CALCI	ERW	VS

Setting of the digital speed references. The overall speed reference is the result of the sum of the values with the respective signs, of **Dig speed ref 1** and **Dig speed ref 2**. The digital speed references are linked to the ramp circuit output.

The overall speed reference is the result of the sum of the values, with sign, of **Speed ref 1** and **Speed ref 2**.

Example 1: **Speed ref 1** = + 500 rpm **Speed ref 2** = + 300 rpm
Speed ref = 500 rpm + 300 rpm = 800 rpm

Example 2: **Speed ref 1** = + 400 rpm **Speed ref 2** = - 600 rpm
Speed ref = 400 rpm – 600 rpm = - 200 rpm

Menu	PAR	Description	UM	Type	FB BIT	Def	Min	Max	Acc	Mod
5.21	650	Speed ref 1 src		LINK	16/32	640	0	16384	ERW	VS
5.22	652	Speed ref 2 src		LINK	16/32	642	0	16384	ERW	VS

Selection of the origin (source) of the drive speed reference signals. The values that can be used as speed references can be selected from those listed in the “**L_MLTREF**” selection list.

When assigning the reference via terminals, signals with $\pm 10V$, 0 ... 10V, 0... 20 mA and 4 ... 20 mA can be used.

Menu	PAR	Description	UM	Type	FB BIT	Def	Min	Max	Acc	Mod
5.23	654	Speed ref invert src		LINK	16	6000	0	16384	ERWZ	VS

Selection of the origin (source) of the signal that inverts the speed reference output from the regulator. The terminal that can be used for this function can be selected from among those listed in the “**L_DIGSEL2**” selection list.

Menu	PAR	Description	UM	Type	FB BIT	Def	Min	Max	Acc	Mod
5.24	660	Speed ref 1 mon	FF	INT16		0	0	0	ER	VS
5.25	662	Speed ref 2 mon	FF	INT16		0	0	0	ER	VS

The value of the relative speed reference is displayed.

Menu	PAR	Description	UM	Type	FB BIT	Def	Min	Max	Acc	Mod
5.26	670	Speed ref top lim	FF	INT32		CALCI	0	CALCI	ERWZ	VS

Setting of the upper speed reference limit. If the speed reference exceeds the limits, the motor speed remains at the set limit value in any case. Speed limits cannot be more than 200% of the value set in the **Full scale speed** parameter (REFERENCES menu par. 680).

Menu	PAR	Description	UM	Type	FB BIT	Def	Min	Max	Acc	Mod
5.27	672	Speed ref bottom lim	FF	INT32		CALCI	CALCI	0	ERWZ	VS

Setting of the lower speed reference limit. If the speed reference exceeds the limits, the motor speed remains at the set limit value in any case. Speed limits cannot be more than 200% of the value set in the **Full scale speed** parameter (REFERENCES menu par. 680).

Menu	PAR	Description	UM	Type	FB BIT	Def	Min	Max	Acc	Mod
5.28	680	Full scale speed	rpm	INT16		CALCI	50	32000	RWZ	VS

Setting of the reference value for all speed percentage data (References, Speed adaptives ...) corresponding to 100 % of the actual speed. This parameter can only be changed with the inverter blocked (Enable drive = Disabled). The recommended setting for the value of this parameter is the motor rated speed. If altered, the self-tuning procedure should be repeated.

Full scale speed does not define the maximum possible speed. In any case, the maximum speed percentage value is ± 200 % of the **Full scale speed** value.

6 – RAMPS

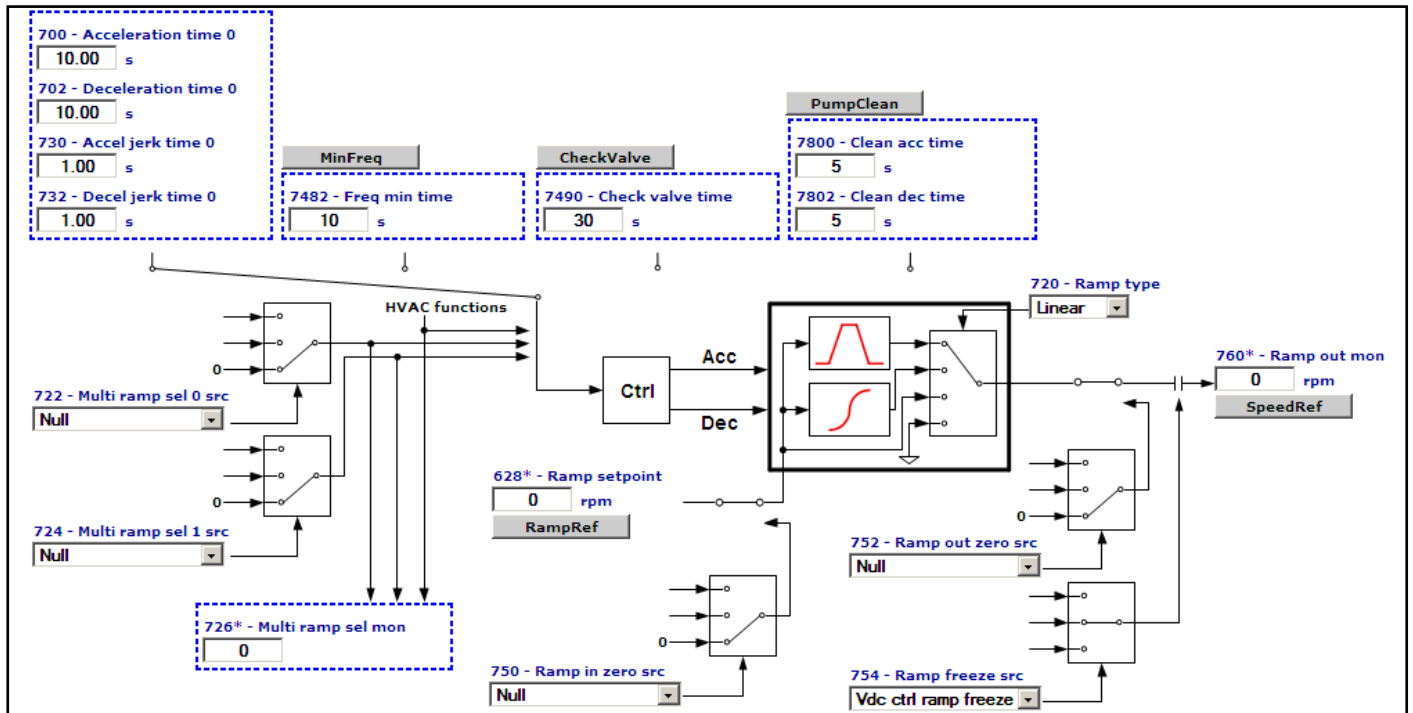

The ramp (reference integrator) determines the acceleration and deceleration times of the drive. Times can be set independently.

The ramp times of Fast stop command are set on **Acceleration time 3** and **Deceleration time 3**. The command can be enabled from the terminal strip..

The ramp can be linear or S-shaped, as preferred.

The references can be set in different ways:

- with the Ramp ref 1 and / or Ramp ref 2 references
- with the Multi speed function
- with the Motor potentiometer function
- with the Jog function

The ramp generator can be used in the “stand alone” mode. When disabled (**Ramp type = Off**), the “Enable drive, Start/Stop and Fast stop” commands do not affect the ramp generator. In this condition the ramp generator can be used separately.

Menu	PAR	Description	UM	Type	FB BIT	Def	Min	Max	Acc	Mod
6.1	700	Acceleration time 0	s	FLOAT		10.00	0.01	1000.00	RW	VS
6.2	702	Deceleration time 0	s	FLOAT		10.00	0.01	1000.00	RW	VS
6.3	704	Acceleration time 1	s	FLOAT		10.00	0.01	1000.00	ERW	VS
6.4	706	Deceleration time 1	s	FLOAT		10.00	0.01	1000.00	ERW	VS
6.5	708	Acceleration time 2	s	FLOAT		10.00	0.01	1000.00	ERW	VS
6.6	710	Deceleration time 2	s	FLOAT		10.00	0.01	1000.00	ERW	VS
6.7	712	Acceleration time 3	s	FLOAT		10.00	0.01	1000.00	ERW	VS
6.8	714	Deceleration time 3	s	FLOAT		10.00	0.01	1000.00	ERW	VS

The acceleration and deceleration ramp times are used to avoid sudden changes in the drive output frequency, which could cause mechanical shocks, excessive current on the motor and excessive DC-bus voltage values. The acceleration times (6.1, 6.3, 6.5, 6.7) are expressed as the time necessary to bring the frequency from zero to the maximum value set in the **Full scale speed (5.22)**. On the other hand, the deceleration times (6.2, 6.4, 6.6, 6.8) are expressed as the time necessary to bring the frequency from the maximum value set in the **Full scale speed (5.22)** parameter to zero. Each of the 4 available ramp selections can be selected using one or two digital inputs programmed as **Multi ramp sel**.

Menu	PAR	Description	UM	Type	FB BIT	Def	Min	Max	Acc	Mod
6.9	720	Ramp type		ENUM		Linear	0	3	ERWZ	VS

This parameter defines the ramp shape (linear/S-shape). It can only be modified with the drive disabled.

- 0 Linear
- 1 S-Shape
- 2 Bypass
- 3 Off

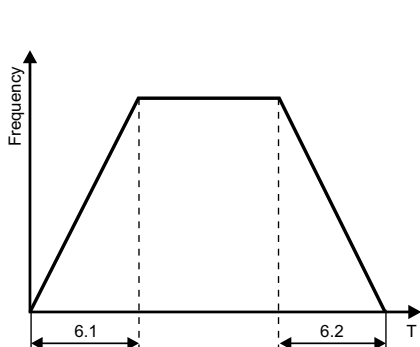

0 = Linear

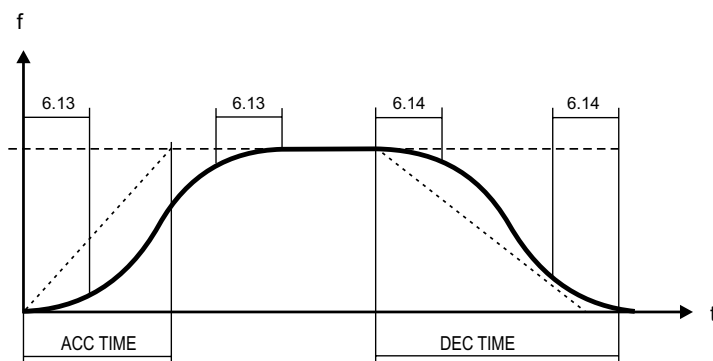

1 = S-Shape

When linear ramps are set (**Linear**) the motor speed varies in a way that is directly in proportion to the frequency.

When S-shape ramps are set (**S-Shape**) it is possible to avoid sudden mechanical variations in the system at the beginning and end of the acceleration and deceleration phase.

The ramp time, meaning the time necessary to accelerate from zero to the maximum frequency value set, is given by the sum of the linear ramp time and that of the associated **Jerks** (see par. 6.13 – 6.20).

The **Bypass** excludes the ramp circuit and the reference is brought directly to the speed regulator input.

With **Off** the ramp reference is set to zero.

Menu	PAR	Description	UM	Type	FB BIT	Def	Min	Max	Acc	Mod
6.10	722	Multi ramp sel 0 src		LINK		6000	0	16384	ERWZ	VS
6.11	724	Multi ramp sel 1 src		LINK		6000	0	16384	ERWZ	VS

1 or 2 digital inputs can be used to select one of the 4 available sets of ramps.

The origin (source) of the command to enable the ramp selection function can be selected from the “**L_DIG-SEL2**” selection list.

The following table describes the ramp selection procedure:

Enabled ramp time	Multi ramp sel 0	Multi ramp sel 1
Acceleration time 0 Deceleration time 0	0	0
Acceleration time 1 Deceleration time 1	1	0
Acceleration time 2 Deceleration time 2	0	1
Acceleration time 3 Deceleration time 3	1	1

Menu	PAR	Description	UM	Type	FB BIT	Def	Min	Max	Acc	Mod
6.12	726	Multi ramp sel mon		UINT16		0	0	3	ER	VS

The set of acceleration/deceleration ramps selected using the digital inputs is displayed.

Menu	PAR	Description	UM	Type	FB BIT	Def	Min	Max	Acc	Mod
6.13	730	Accel jerk time 0	s	FLOAT		1.0	0.02	10.0	ERW	VS
6.14	732	Decel jerk time 0	s	FLOAT		1.0	0.02	10.0	ERW	VS
6.15	734	Accel jerk time 1	s	FLOAT		1.0	0.02	10.0	ERW	VS
6.16	736	Decel jerk time 1	s	FLOAT		1.0	0.02	10.0	ERW	VS
6.17	738	Accel jerk time 2	s	FLOAT		1.0	0.02	10.0	ERW	VS
6.18	740	Decel jerk time 2	s	FLOAT		1.0	0.02	10.0	ERW	VS
6.19	742	Accel jerk time 3	s	FLOAT		1.0	0.02	10.0	ERW	VS
6.20	744	Decel jerk time 3	s	FLOAT		1.0	0.02	10.0	ERW	VS

Jerks are variations of acceleration in time. They are used when there is a need to dampen the beginning and end of the ramp. The Jerk value is added, regardless of the variation in speed, to the linear ramp time.

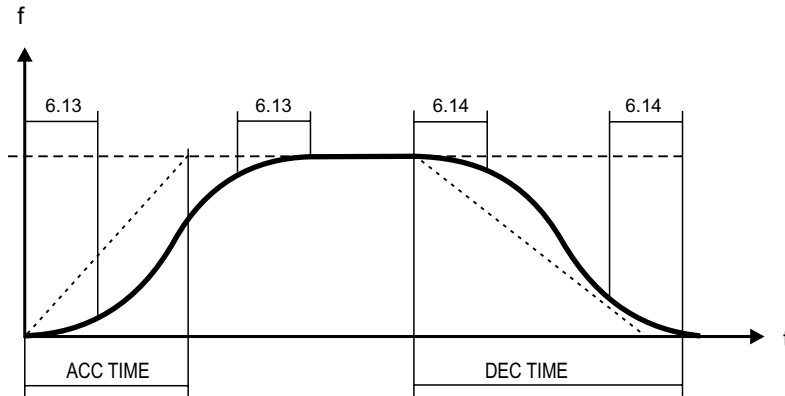

Menu	PAR	Description	UM	Type	FB BIT	Def	Min	Max	Acc	Mod
6.21	750	Ramp in zero src		LINK	16	6000	0	16384	ERW	VS

Selection of the origin (source) of the signal that blocks the ramp input and moves the reference to zero. If the ramp input is enabled, the **Ramp ref** parameter corresponds to the set reference. If the ramp input is blocked, the drive slows down with the set deceleration time until reaching zero speed. The terminal to be associated with this function can be selected from the “**L_DIGSEL2**” selection list.

Menu	PAR	Description	UM	Type	FB BIT	Def	Min	Max	Acc	Mod
6.22	752	Ramp out zero src		LINK	16	6000	0	16384	ERW	VS

Selection of the origin (source) of the signal that brings the ramp to 0 (**Ramp ref 1/Ramp ref 2 = 0**). When the ramp output is set to zero using **Ramp out zero**, the drive brakes with the maximum available torque; in this case the ramp is disabled. The terminal to be associated with this function can be selected from the “**L_DIGSEL2**” selection list.

Menu	PAR	Description	UM	Type	FB BIT	Def	Min	Max	Acc	Mod
6.23	754	Ramp freeze src		LINK	16	3480	0	16384	ERW	VS

Selection of the origin (source) of the signal that temporarily freezes the ramp output value, regardless of any changes in the input reference. The terminal to be associated with this function can be selected from the “**L_DIGSEL2**” selection list.

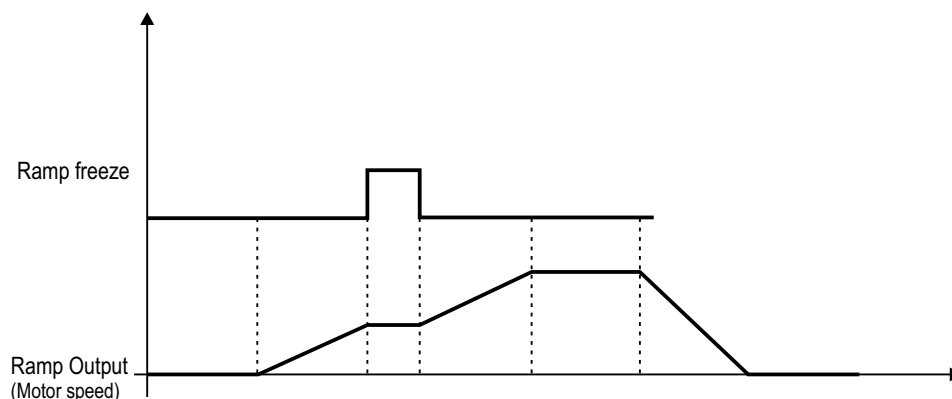

7 – MULTI REFERENCE

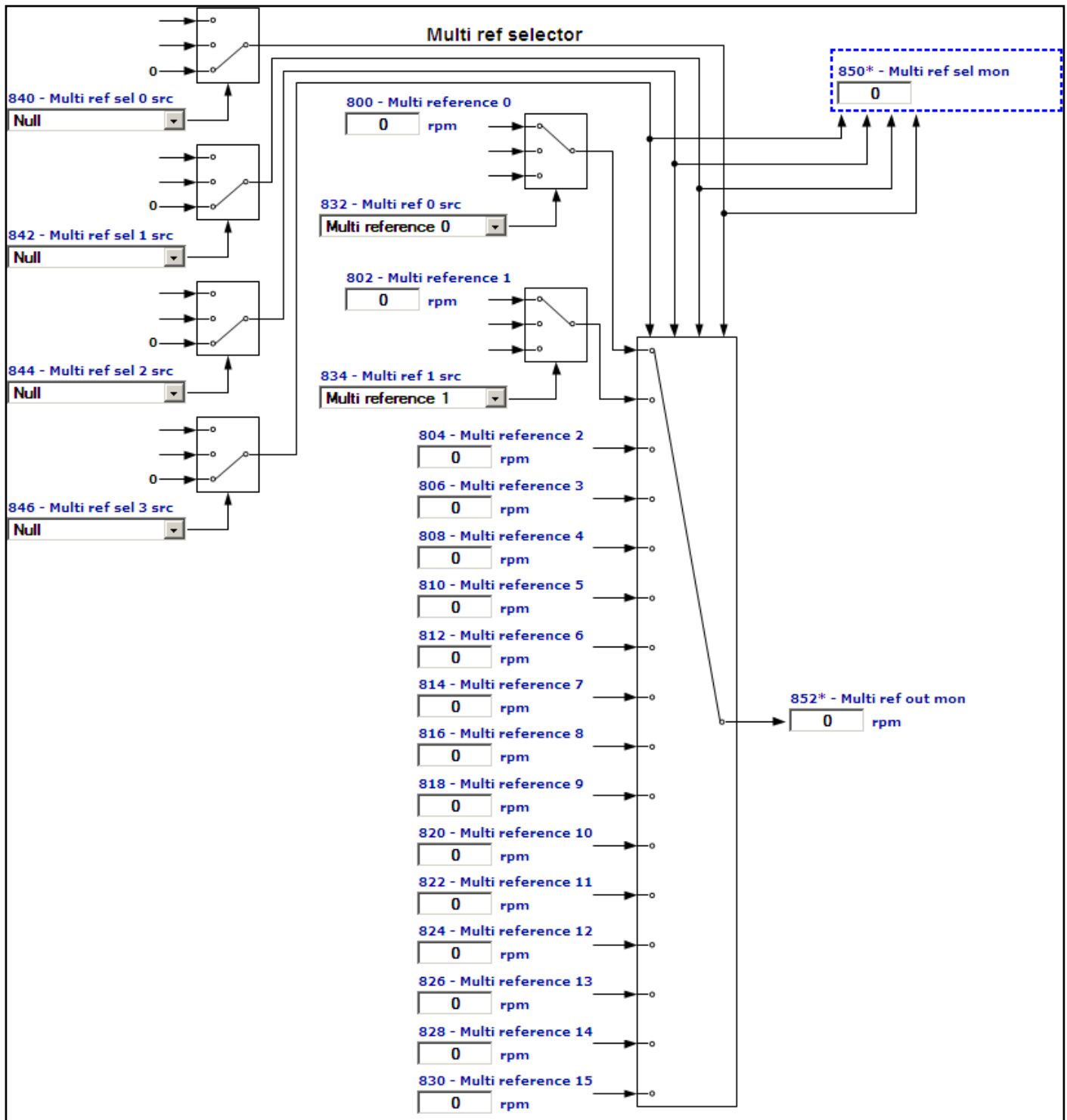

With the “Multispeed” function (**Multi references**) it is possible to recall up to sixteen internally saved speed references to be recalled using a digital signal or via digital inputs on the terminal strip.

Menu	PAR	Description	UM	Type	FB BIT	Def	Min	Max	Acc	Mod
7.1	800	Multi reference 0	FF	INT16	16/32	0	CALCI	CALCI	RW	VS
7.2	802	Multi reference 1	FF	INT16	16/32	0	CALCI	CALCI	RW	VS
7.3	804	Multi reference 2	FF	INT16		0	CALCI	CALCI	RW	VS
7.4	806	Multi reference 3	FF	INT16		0	CALCI	CALCI	RW	VS
7.5	808	Multi reference 4	FF	INT16		0	CALCI	CALCI	RW	VS
7.6	810	Multi reference 5	FF	INT16		0	CALCI	CALCI	RW	VS

7.7	812	Multi reference 6	FF	INT16	0	CALCI	CALCI	RW	VS
7.8	814	Multi reference 7	FF	INT16	0	CALCI	CALCI	RW	VS
7.9	816	Multi reference 8	FF	INT16	0	CALCI	CALCI	ERW	VS
7.10	818	Multi reference 9	FF	INT16	0	CALCI	CALCI	ERW	VS
7.11	820	Multi reference 10	FF	INT16	0	CALCI	CALCI	ERW	VS
7.12	822	Multi reference 11	FF	INT16	0	CALCI	CALCI	ERW	VS
7.13	824	Multi reference 12	FF	INT16	0	CALCI	CALCI	ERW	VS
7.14	826	Multi reference 13	FF	INT16	0	CALCI	CALCI	ERW	VS
7.15	828	Multi reference 14	FF	INT16	0	CALCI	CALCI	ERW	VS
7.16	830	Multi reference 15	FF	INT16	0	CALCI	CALCI	ERW	VS

It is possible to select up to 16 operating frequencies, which can be set in these parameters.

The frequencies are selected using the binary code of the digital inputs programmed using the **Multi ref sel 0 src**, **Multi ref sel 1 src**, **Multi ref sel 2 src** and **Multi ref sel 3 src** parameters.

References can be set via the keypad, serial line, digital inputs and BUS.

A sign can be given to the references, so that when they are defined so too is the desired direction of rotation.

Menu	PAR	Description	UM	Type	FB BIT	Def	Min	Max	Acc	Mod
7.17	832	Multi ref 0 src		LINK	16/32	800	0	16384	RW	VS
7.18	834	Multi ref 1 src		LINK	16/32	802	0	16384	RW	VS

Selection of the origin (source) of the drive speed reference signals. The speed reference values can be selected from those listed in the “**L_MLTREF**” selection list.

Menu	PAR	Description	UM	Type	FB BIT	Def	Min	Max	Acc	Mod
7.19	840	Multi ref sel 0 src		LINK	16	6000	0	16384	RW	VS
7.20	842	Multi ref sel 1 src		LINK	16	6000	0	16384	RW	VS
7.21	844	Multi ref sel 2 src		LINK	16	6000	0	16384	RW	VS
7.22	846	Multi ref sel 3 src		LINK	16	6000	0	16384	ERW	VS

Selection of the origin (source) of the signals used to select one of the preset speeds. These parameters can only be used together in combinations. The terminals that can be used for this function can be selected from among those listed in the “**L_DIGSEL2**” selection list.

The following table describes the selection of the Multispeed function:

Active speed ref	Multi ref sel 0 src	Multi ref sel 1 src	Multi ref sel 2 src	Multi ref sel 3 src
Multi reference 0	0	0	0	0
Multi reference 1	1	0	0	0
Multi reference 2	0	1	0	0
Multi reference 3	1	1	0	0
Multi reference 4	0	0	1	0
Multi reference 5	1	0	1	0
Multi reference 6	0	1	1	0
Multi reference 7	1	1	1	0
Multi reference 8	0	0	0	1
Multi reference 9	1	0	0	1
Multi reference 10	0	1	0	1
Multi reference 11	1	1	0	1
Multi reference 12	0	0	1	1
Multi reference 13	1	0	1	1

Active speed ref	Multi ref sel 0 src	Multi ref sel 1 src	Multi ref sel 2 src	Multi ref sel 3 src
Multi reference 14	0	1	1	1
Multi reference 15	1	1	1	1

The following figure describes the selection of a control for 8 Multispeeds.

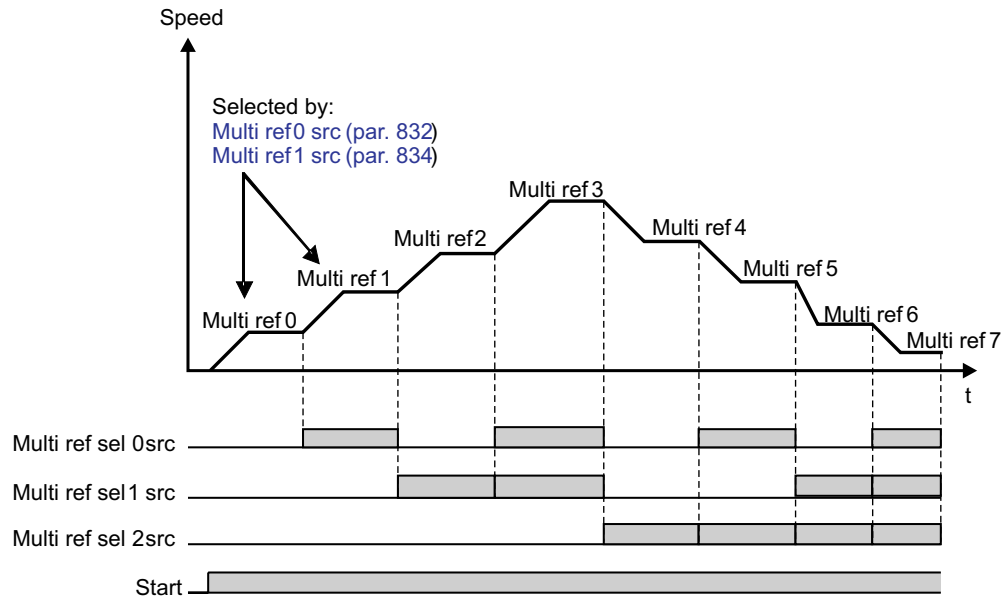

Menu	PAR	Description	UM	Type	FB BIT	Def	Min	Max	Acc	Mod
7.23	850	Multi ref sel mon		UINT16		0	0	15	R	VS

The multispeed that has been selected using the digital commands or by the digital inputs selected in the terminal strip.

Menu	PAR	Description	UM	Type	FB BIT	Def	Min	Max	Acc	Mod
7.24	852	Multi ref out mon	FF	INT16	16/32	0	0	0	R	VS

The selected speed reference on the Multispeed block output is displayed.

8 – MOTORPOTENTIOMETER

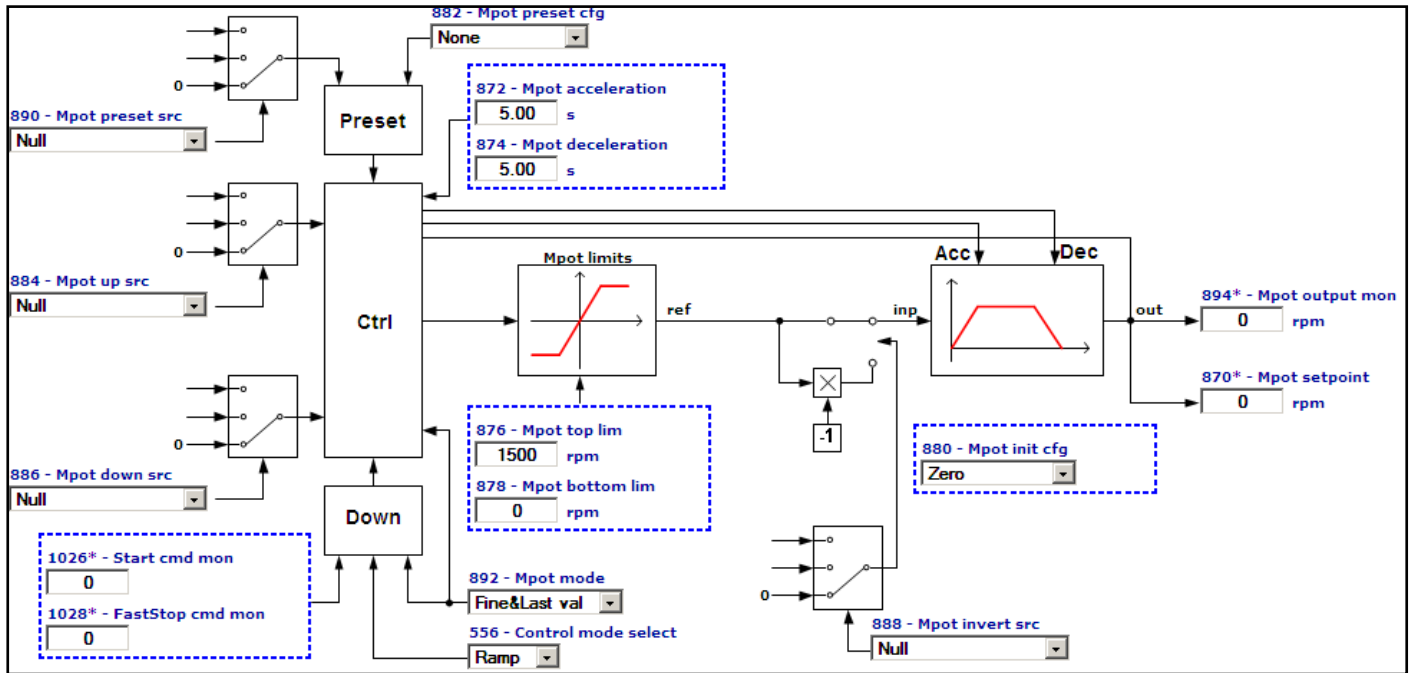

The Motor potentiometer function allows the speed reference of the drive to be changed by pressing buttons with which the UP and DOWN commands are associated.

The UP and DOWN commands can be sent from the keypad, by digital inputs, the serial line or fieldbus.

To send the UP and DOWN commands from the keypad, enter the **MPot setpoint** parameter modify mode and press the UP and DOWN keys.

The UP and DOWN commands increase or decrease the speed of the motor for as long as they are present. The simultaneous presence of both commands will not produce any change (see time chart).

The speed changes according to the set ramp times and within the set lower and upper limits.

The value of the Motor potentiometer function output at drive power-on can be configured.

The preset command can be used to force a preset value for the input and output of the Motor potentiometer function.

The invert command can be used to force an inversion of the reference sign of the Motor potentiometer function.

In the default condition, the speed reference produced by the Motor potentiometer function is connected in input to the Ramp function. For direct control of the motor speed, the Acceleration time and Deceleration time parameters in the RAMP menu should be set = 0.

Note ! The Motor potentiometer function produces a speed reference. Therefore a RUN command must always be sent to start motor rotation.

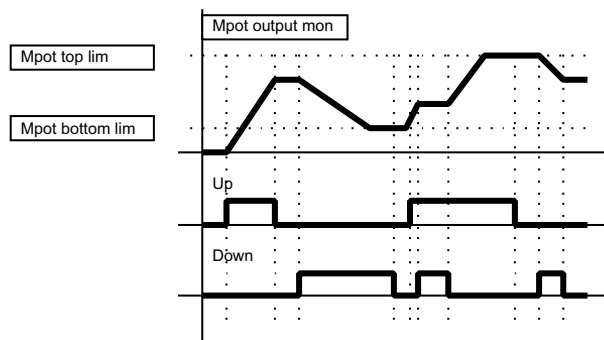

Menu	PAR	Description	UM	Type	FB BIT	Def	Min	Max	Acc	Mod
8.1	870	Mpot setpoint	rpm	INT16	16/32	0	CALCI	CALCI	R	VS

The speed reference value of the Motor potentiometer function is displayed.
Enter this parameter to send the UP and DOWN commands from the keypad.

Menu	PAR	Description	UM	Type	FB BIT	Def	Min	Max	Acc	Mod
8.2	872	Mpot acceleration	s	FLOAT		5.0	0.01	1000.00	RW	VS
8.3	874	Mpot deceleration	s	FLOAT		5.0	0.01	1000.00	RW	VS

Setting of the acceleration/deceleration ramp times (in seconds) used with the Motor potentiometer function.

Menu	PAR	Description	UM	Type	FB BIT	Def	Min	Max	Acc	Mod
8.4	876	Mpot top lim	rpm	INT16		PAR 680	CALCI	CALCI	ERW	VS

Setting of the top limit for the speed reference output from the motor potentiometer.

Menu	PAR	Description	UM	Type	FB BIT	Def	Min	Max	Acc	Mod
8.5	878	Mpot bottom limit	rpm	INT16		0	CALCI	CALCI	ERW	VS

Setting of the bottom limit for the speed reference output from the motor potentiometer.

Menu	PAR	Description	UM	Type	FB BIT	Def	Min	Max	Acc	Mod
8.6	880	Mpot init cfg		ENUM		Zero	0	3	ERW	VS

Use this parameter to configure the output value of the Motor potentiometer at drive start-up.

- 0 Last power off
- 1 Zero
- 2 Lower Limit
- 3 Upper Limit

When set to **Last power off**, the motor potentiometer output starts from the last frequency that was set before the drive was switched off.

When set to **Zero** the motor potentiometer output starts from a value of 0.

When set to **Lower limit** the output of the motor potentiometer starts from the value of the lower limit set in the **Mpot bottom limit** parameter.

When set to **Upper limit** the output of the motor potentiometer starts from the value of the upper limit set in the **Mpot top limit** parameter.

Menu	PAR	Description	UM	Type	FB BIT	Def	Min	Max	Acc	Mod
8.7	882	Mpot preset cfg		ENUM		None	0	11	ERW	VS

This parameter can be used to configure the preset of the Motor potentiometer function, i.e. to configure the value at which the Motor potentiometer input and output are set when the Preset command is enabled.

The Preset command has priority over the Up command and the Down command.

Mpot mode (PAR 892) = [1] **Ramp&Follow** has priority over the Preset command, i.e. actions programmed with **Mpot preset cfg** (PAR 882) are not executed.

The Up and Down commands are enabled again when the Preset command is disabled.

- 0 None
- 1 Input = 0
- 2 Input = low lim
- 3 Input & ref = 0
- 4 Input & ref = low lim
- 5 Output = 0
- 6 Output = low lim
- 7 Output & ref = 0
- 8 Output & ref = low lim
- 9 Input = upp lim
- 10 Input & ref = upp lim
- 11 Freeze input

When set to **None**, no setting is executed.

Input = 0 sets input = 0 i.e. a temporary reference setting is performed and the previous reference value is maintained. The output of the Motor potentiometer function varies with the set ramp times. The previous reference value is restored when the preset command is removed.

Input = low lim sets Inp = low lim i.e. a temporary reference setting is performed and the previous reference value is maintained. The output of the Motor potentiometer function varies with the set ramp times. The previous reference value is restored when the preset command is removed.

Input & ref = 0 sets Inp = 0 and Ref = 0 i.e. a definitive reference setting is performed. The output of the Motor potentiometer function varies with the set ramp times.

Input & ref = low lim sets Inp = low lim and Ref = low lim i.e. a definitive reference setting is performed. The output of the Motor potentiometer function varies with the set ramp times.

Output = 0 sets Out = 0 i.e. a temporary output setting for the Motor potentiometer function is performed. The previous reference value is maintained. If the preset command is enabled, the output of the Motor potentiometer function continues to be = 0, if the preset command is not enabled the output of the Motor potentiometer function varies with the set ramp times.

Output = low lim sets Out = low lim i.e. a temporary setting for the output of the Motor potentiometer function is performed. The previous reference value is maintained. If the preset command is enabled, the output of the Motor potentiometer function continues to be = low lim, if the preset command is not enabled the output of the Motor potentiometer function varies with the set ramp times.

Output & ref = 0 sets Out = 0 i.e. a definitive setting for the output of the Motor potentiometer function is performed.

Output & ref = low lim sets Out = low lim i.e. a definitive setting for the output of the Motor potentiometer function is performed.

Input = upp lim sets Inp = upp lim i.e. a temporary setting for the reference is performed and the previous reference value is maintained. The output of the Motor potentiometer function varies with the set ramp times. The previous reference value is restored when the preset command is removed.

Input & ref = upp lim sets Inp = upp lim and Ref = upp lim i.e. a definitive reference setting is performed. The output of the Motor potentiometer function varies with the set ramp times.

When **Freeze input** is set, the Up and Down commands are temporarily disabled.

Menu	PAR	Description	UM	Type	FB BIT	Def	Min	Max	Acc	Mod
8.8	884	Mpot up src		LINK	16	6000	0	16384	RW	VS

Selection of the origin (source) of the signal that increases the speed reference of the motor potentiometer with the set ramp. The terminal to be associated with this function can be selected from the “**L_DIGSEL2**” selection list.

Menu	PAR	Description	UM	Type	FB BIT	Def	Min	Max	Acc	Mod
8.9	886	Mpot down src		LINK	16	6000	0	16384	RW	VS

Selection of the origin (source) of the signal that decreases the speed reference of the motor potentiometer with the set ramp. The terminal to be associated with this function can be selected from the “**L_DIGSEL2**” selection list.

Menu	PAR	Description	UM	Type	FB BIT	Def	Min	Max	Acc	Mod
8.10	888	Mpot invert src		LINK	16	6000	0	16384	ERW	VS

Selection of the origin (source) of the signal that inverts the speed reference of the motor potentiometer. The terminal to be associated with this function can be selected from the “**L_DIGSEL2**” selection list.

Menu	PAR	Description	UM	Type	FB BIT	Def	Min	Max	Acc	Mod
8.11	890	Mpot preset src		LINK	16	6000	0	16384	ERW	VS

Selection of the origin (source) of the signal to preset the motor potentiometer function. The signal to be associated with this function can be selected from the “**L_DIGSEL2**” selection list.

Menu	PAR	Description	UM	Type	FB BIT	Def	Min	Max	Acc	Mod
8.12	892	Mpot mode		ENUM		Fine&Last val	0	3	ERW	VS

Setting of the configuration of two possible options of the Motor potentiometer function. There are two operating modes for each of the two options.

- 0 Ramp&Last val
- 1 Ramp&Follow
- 2 Fine&Last val
- 3 Fine&Follow

Option 1: Behaviour of the Motor potentiometer function with the Stop or FastStop command present with the **Control mode = Ramp** parameter.

The two operating modes are: **Last val** or **Follow**.

With the Control mode not equal to Ramp setting, this option is not completely applicable and it always behaves in Last val mode.

In **Last val** mode with the Stop or FastStop command present, the speed reference of the Motor potentiometer function is not altered.

The motor speed moves to 0 according to the selected control mode (**Control mode = Ramp** or **Control mode = Speed**). When the Run command is sent, the motor speed moves to the speed reference set by the motor potentiometer function according to the selected control mode.

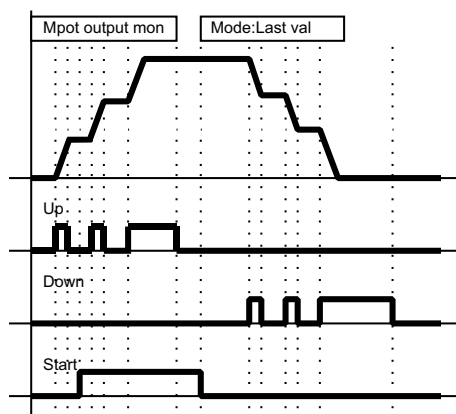

In **Follow** mode with the Stop or FastStop command present, the Down command is simulated, i.e. the output of the Motor potentiometer function moves to 0 with the set ramp time.

If the Run command is sent when the 0 speed has been reached, it is maintained until the Up command is sent. If the Run command is sent before the motor reaches the 0 speed, the speed at that moment is taken as the new reference.

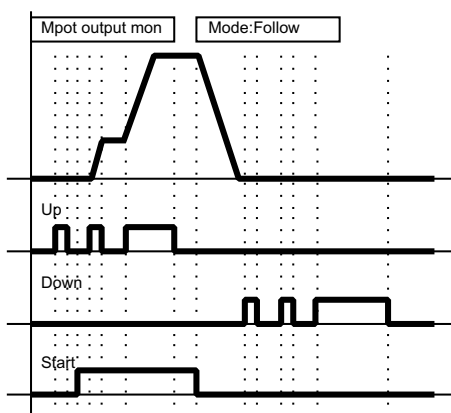

Option 2: Ramp behaviour

The two operating modes are: **Ramp** or **Fine**

In **Ramp** mode, each time the Up or Down commands are enabled, the output of the Motor potentiometer function increases or decreases with the set ramp. When the Up or Down command is removed, the last value that was reached is maintained.

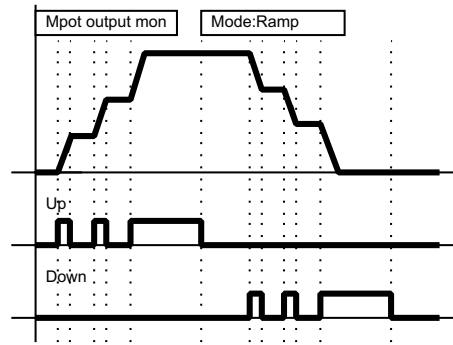

In **Fine** mode, each time the Up or Down commands are enabled, the output of the Motor potentiometer function increases or decreases by 1 rpm.

If the command persists for less than 1 second, no other changes are made on the output.

If the command persists for more than 1 second, the output increases or decreases with the set ramp. The variation with the set ramp is performed gradually (1 second). When the Up or Down command is removed the last value that was reached is maintained.

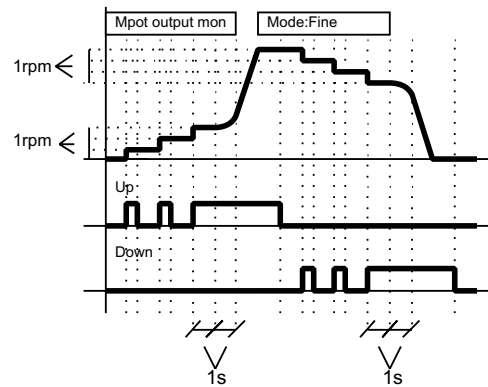

Mpot mode	Ramp behaviour	Behaviour of the Motor potentiometer function with the Stop or FastStop command present with the Control mode = Ramp parameter.
0	Ramp	Last val
1	Ramp	Follow
2	Fine	Last val
3	Fine	Follow

Menu	PAR	Description	UM	Type	FB BIT	Def	Min	Max	Acc	Mod
8.13	894	Mpot output mon	rpm	INT16	16/32	0	0	0	ER	VS

The value of the output of the motor potentiometer function is displayed.

Two examples of application of the motor potentiometer function are shown below.

Manual speed control with command sent from control desk.

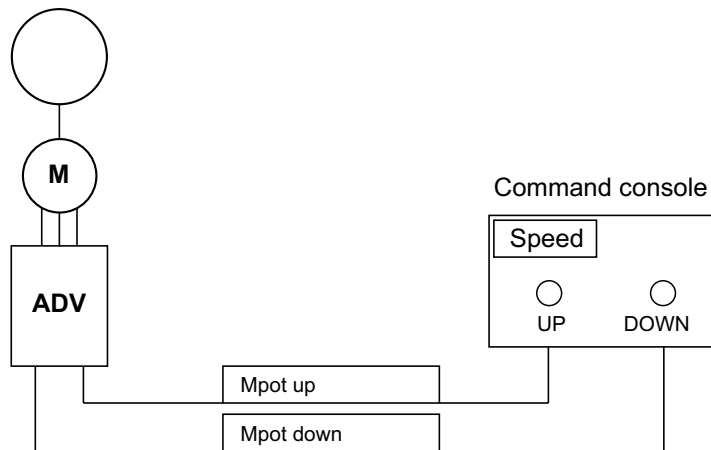

The Up and Down keys are used to adjust the speed of a motor.

For fine-tuning of the speed reference value the recommended settings are **Mpot Mode = Fine&Follow** or **Fine&Last Val**. Each time they are pressed for 1 second, the speed increases by 1 rpm. For an immediate effect on motor speed, the Acceleration time and Deceleration time parameters should be set to short times.

9 – JOG FUNCTION

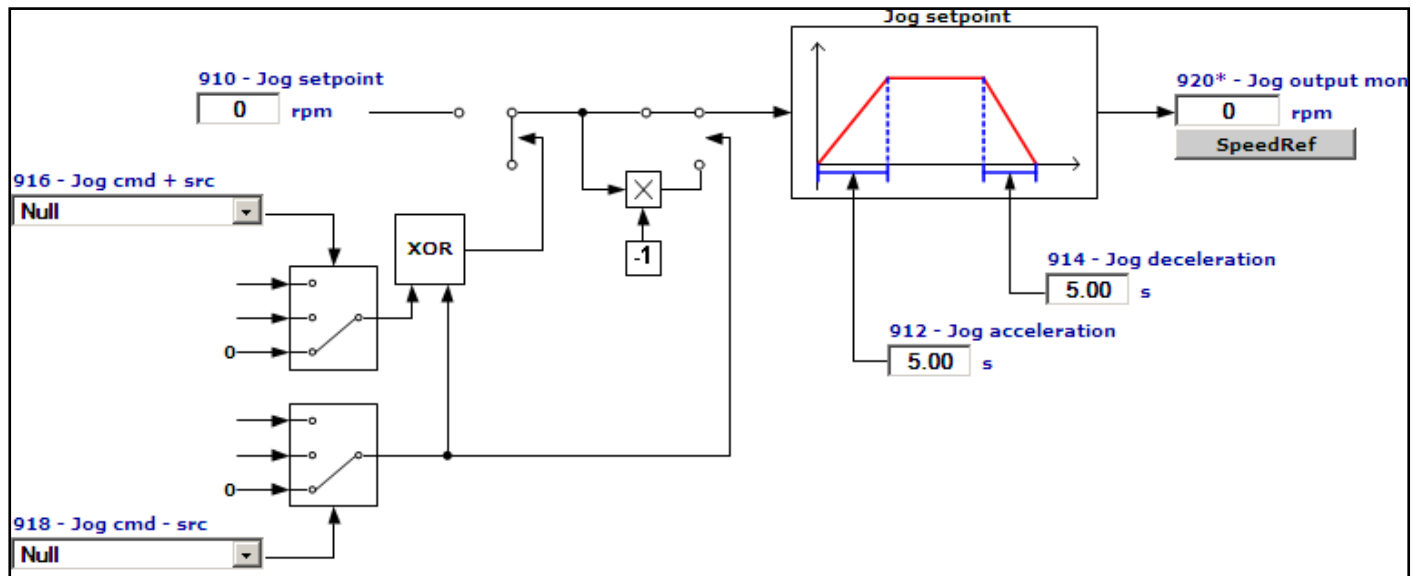

Menu	PAR	Description	UM	Type	FB BIT	Def	Min	Max	Acc	Mod
9.1	910	Jog setpoint	rpm	INT16		0	CALCI	CALCI	RW	VS

The reference for Jog mode operation. This reference can also be set via an analog input. The **Jog** reference is enabled when the signal used for the **Jog +** or **Jog -** command is enabled, the Run command is not present and the drive output frequency is zero.

Menu	PAR	Description	UM	Type	FB BIT	Def	Min	Max	Acc	Mod
9.2	912	Jog acceleration	s	FLOAT		5.0	0.01	1000.00	RW	VS
9.3	914	Jog deceleration	s	FLOAT		5.0	0.01	1000.00	RW	VS

Setting of the acceleration/deceleration ramp time (in seconds) used during **Jog** operation.

Menu	PAR	Description	UM	Type	FB BIT	Def	Min	Max	Acc	Mod
9.4	916	Jog cmd + src		LINK	16	6000	0	16384	RW	VS

Selection of the origin (source) of the **Jog +** function enabling signal. When this command is enabled it generates a Jog Mode reference with a sign matching the value entered for the **Jog setpoint value** parameter. The signal to be associated with this function can be selected from the “L_DIGSEL2” selection list.

Note ! The **Run** command has priority over the **Jog +** command.

Menu	PAR	Description	UM	Type	FB BIT	Def	Min	Max	Acc	Mod
9.5	918	Jog cmd - src		LINK	16	6000	0	16384	RW	VS

Selection of the origin (source) of the **Jog -** function enabling signal. When this command is enabled the Jog Mode reference sign is inverted with respect to the value entered in the **Jog setpoint value** parameter. The signal to be associated with this function can be selected from the “L_DIGSEL2” selection list.

Note ! The **Run** command has priority over the **Jog -** command.

Menu	PAR	Description	UM	Type	FB BIT	Def	Min	Max	Acc	Mod
9.6	920	Jog output mon	rpm	INT16	16/32	0	0	0	ER	VS

The speed reference used by the **Jog** command is displayed.

10 – MONITOR FUNCTION

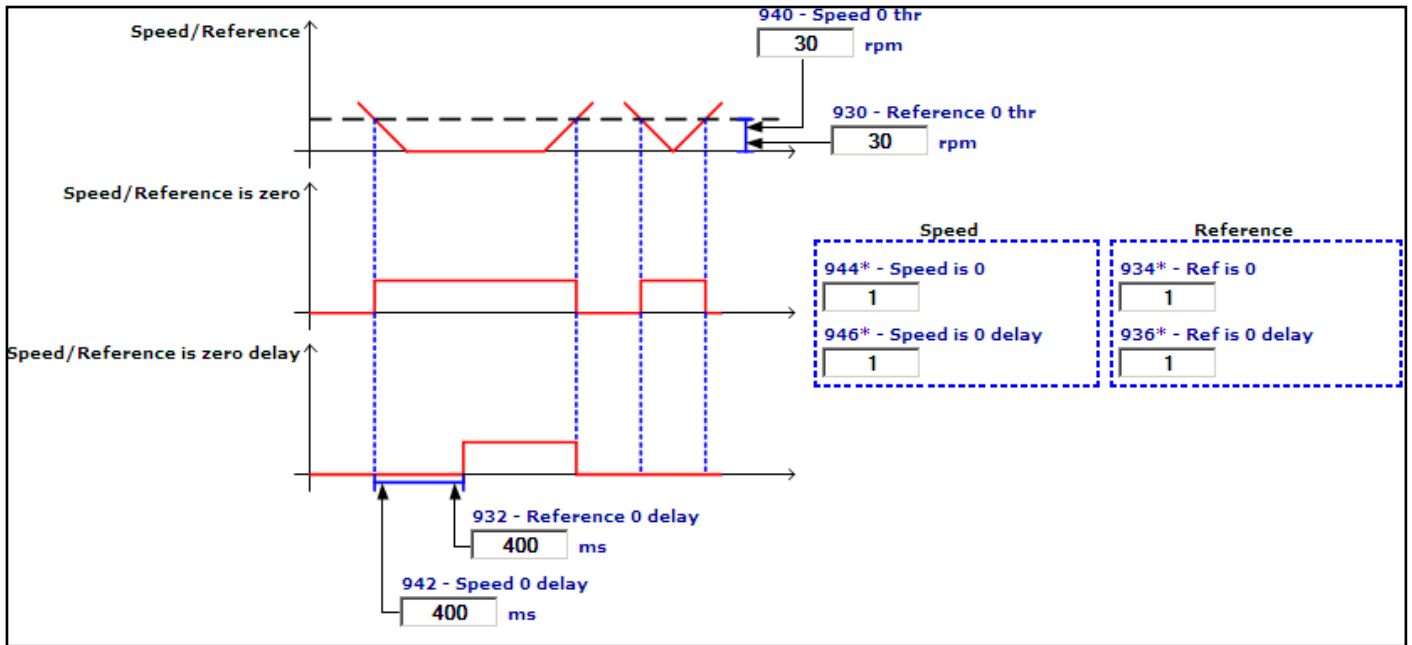

Menu	PAR	Description	UM	Type	FB BIT	Def	Min	Max	Acc	Mod
10.1	930	Reference 0 thr	rpm	INT16		30	0		CALCI	RW VS

Setting of the threshold for recognition of the speed = 0 reference. The value is valid for both directions of rotation.

Menu	PAR	Description	UM	Type	FB BIT	Def	Min	Max	Acc	Mod
10.2	932	Reference 0 delay	ms	UINT16		400	0	10000	RW	VS

Setting of the delay in milliseconds after which the reference = 0 reached signal is enabled.

Menu	PAR	Description	UM	Type	FB BIT	Def	Min	Max	Acc	Mod
10.3	940	Speed 0 thr	rpm	INT16		30	0		CALCI	RW VS

Setting of the threshold for recognizing speed value = 0. The value is valid for both directions of rotation.

Menu	PAR	Description	UM	Type	FB BIT	Def	Min	Max	Acc	Mod
10.4	942	Speed 0 delay	ms	UINT16		400	0	10000	RW	VS

Setting of the delay in milliseconds after which the speed = 0 reached signal is enabled.

When the motor reaches a speed that is below the zero speed threshold, it stops and the $n=0$ LED lights up.

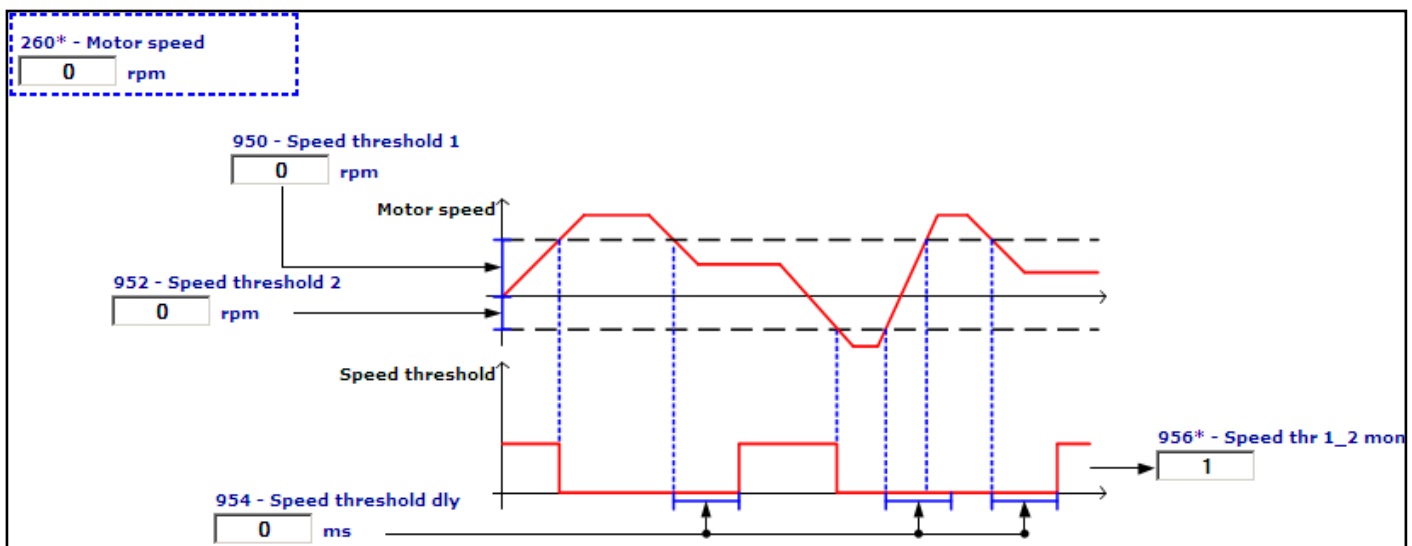

Menu	PAR	Description	UM	Type	FB BIT	Def	Min	Max	Acc	Mod
10.5	950	Speed threshold 1	rpm	INT32		0	CALCI	CALCI	RW	VS

Setting of speed threshold 1 (upper). When the threshold is exceeded the **Speed threshold** signal is disabled, with a delay that can be set in **Speed threshold dly**.

Menu	PAR	Description	UM	Type	FB BIT	Def	Min	Max	Acc	Mod
10.6	952	Speed threshold 2	rpm	INT32		0	CALCI	CALCI	RW	VS

Setting of speed threshold 2 (lower). When the threshold is exceeded the **Speed threshold** signal is disabled, with a delay that can be set in **Speed threshold dly**.

Menu	PAR	Description	UM	Type	FB BIT	Def	Min	Max	Acc	Mod
10.7	954	Speed threshold dly	ms	UINT16		0	0	50000	RW	VS

Setting of the delay after which the transition from 0 ⇒ 1 is activated. The transition from 0 ⇒ 1 occurs when the speed is within the set limits. **The Speed threshold signal transition from 1 ⇒ 0 is always immediate.**

If the motor speed is between **Speed threshold 1** and **Speed threshold 2**, the **Speed threshold** signal is active. If **Speed threshold 1** < **Speed threshold 2** the **Speed threshold** signal is not significant.

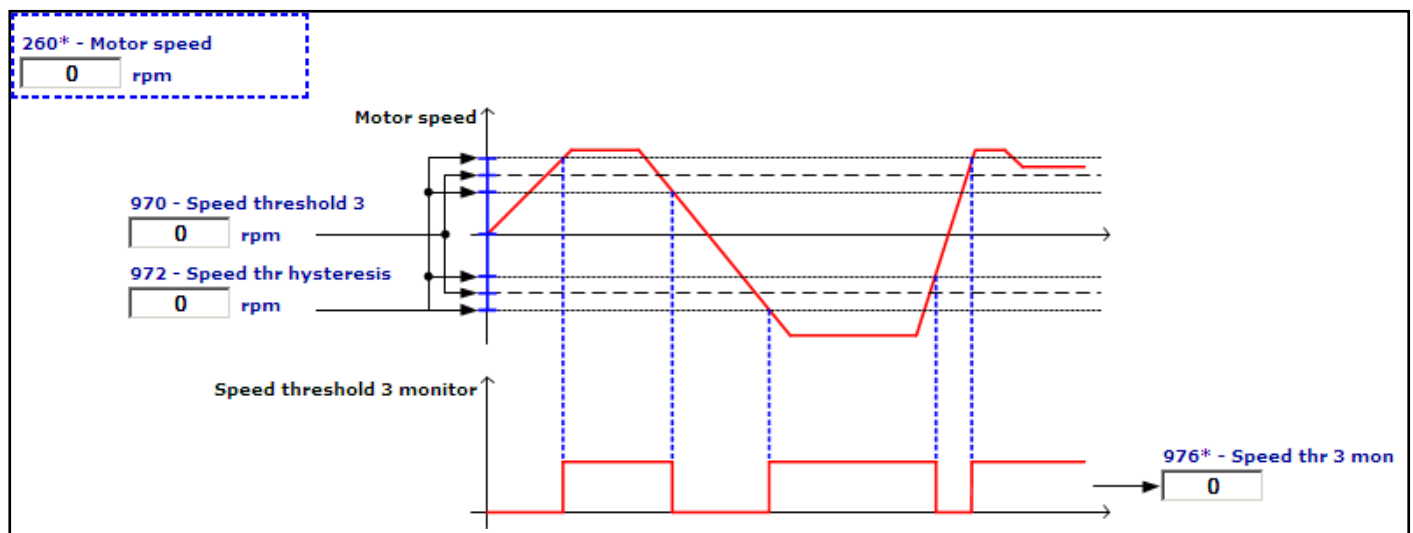

Menu	PAR	Description	UM	Type	FB BIT	Def	Min	Max	Acc	Mod
10.8	960	Set speed ref src		LINK	16/32	628	0	16384	ERW	VS

Selection of the origin (source) of the signal used as speed reference and on which the speed reached control is performed (for control with ramp, use **Ramp setpoint**, for control without ramp, use **Speed setpoint**). The signal that can be used as the speed reference can be selected from among those listed in the “**L_CMP**” selection list.

Menu	PAR	Description	UM	Type	FB BIT	Def	Min	Max	Acc	Mod
10.9	962	Set speed error	rpm	INT16		100	0	CALCI	RW	VS

Setting of the bandwidth of the tolerance within which, even if the speed is not equal to the reference, the two values are considered to coincide and the **Set speed** signal is enabled.

Menu	PAR	Description	UM	Type	FB BIT	Def	Min	Max	Acc	Mod
10.10	964	Set speed delay	ms	UINT16		0	0	50000	RW	VS

Setting of a delay in ms before the signal (**Set speed** programmed on a digital output), if the speed is within a tolerance band defined by the **Set speed error** parameter, after which the transition from 0 ⇒ 1 is enabled.

The transition of the Set Speed signal from 0 ⇒ 1 is always immediate.

Menu	PAR	Description	UM	Type	FB BIT	Def	Min	Max	Acc	Mod
10.11	968	Dig set speed ref	rpm	UINT16	16/32BIT	0	CALCI	CALCI	RW	VS

Setting of the threshold used as the speed reference: this parameter is used to set a fixed threshold regardless of the speed reference.

Menu	PAR	Description	UM	Type	FB BIT	Def	Min	Max	Acc	Mod
10.12	970	Speed threshold 3	rpm	INT32		0	0	CALCI	ERW	VS

Setting of the speed 3 threshold. When this threshold + the tolerance band set in parameter **972 Speed thr hysteresis** are exceeded, parameter **976 Speed thr 3 mon** is enabled. The signal is disabled when the motor speed falls below the threshold - the tolerance band. If the threshold value is lower than the value set in **972 Speed thr hysteresis**, the result produced is always 0. The value set in this parameter is active in both directions of rotation.

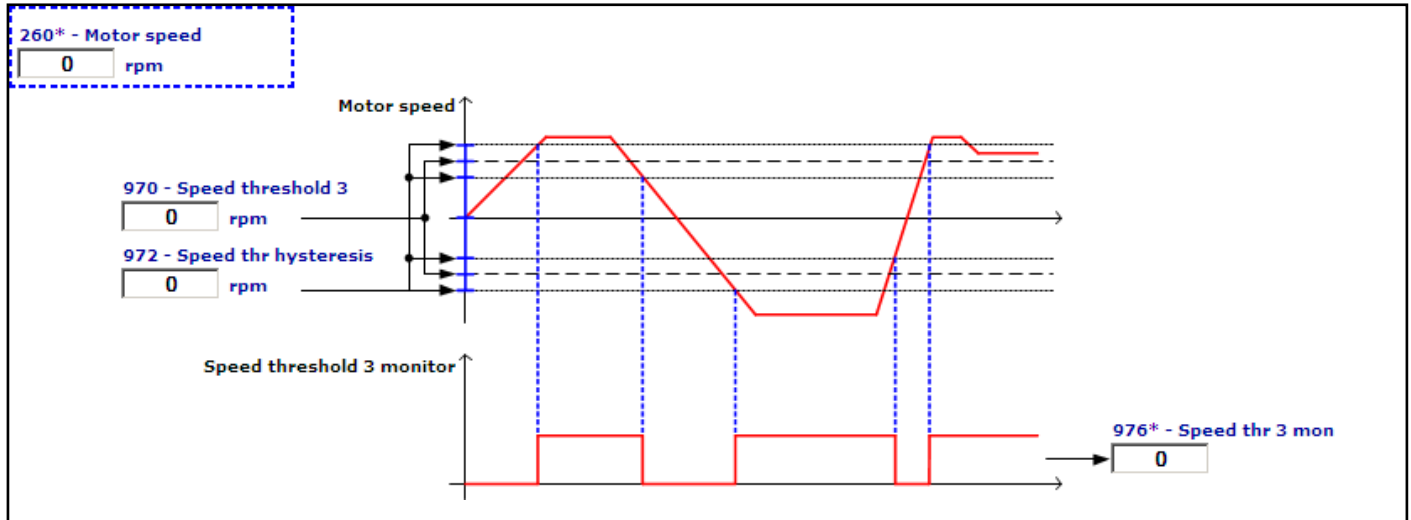

Menu	PAR	Description	UM	Type	FB BIT	Def	Min	Max	Acc	Mod
10.13	972	Speed thr hysteresis	rpm	UINT16		0	0	CALCI	RW	VS

Setting of the tolerance band around **Speed threshold 3**. The tolerance band is the same for both directions of rotation of the motor.

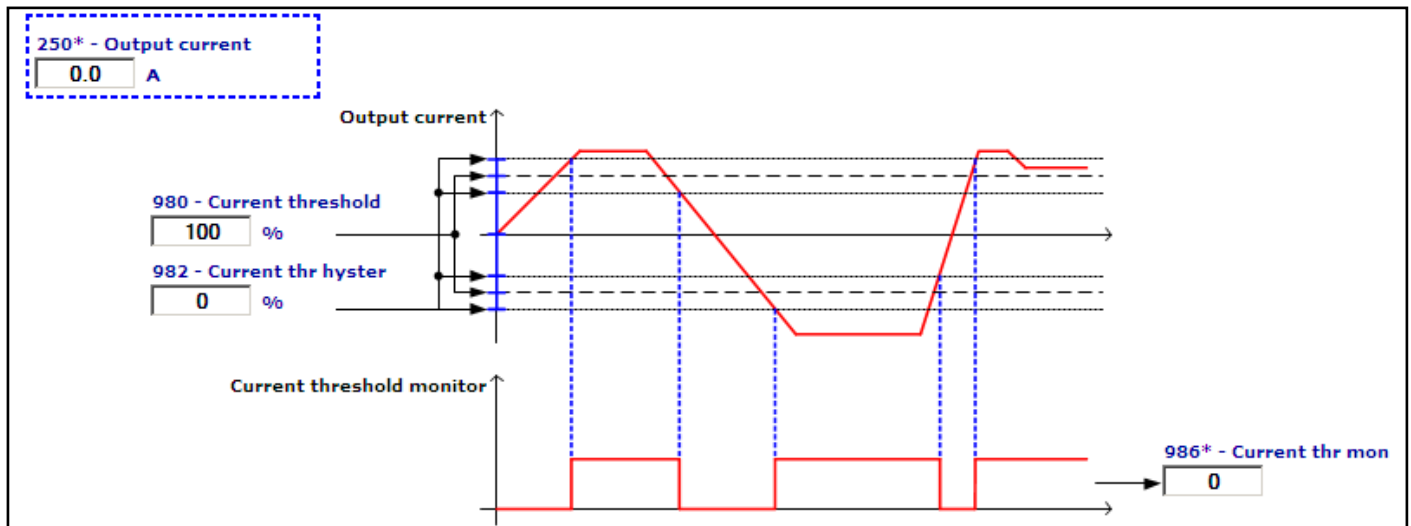

Menu	PAR	Description	UM	Type	FB BIT	Def	Min	Max	Acc	Mod
10.14	980	Current threshold	perc	UINT16		100	0	200	RW	VS

Setting of the current threshold. A value of 100% corresponds to the value of the drive continuous current, displayed in parameter **488 Drive cont current**, when no derating of the drive continuous current has been activated due to any modification of Mains voltage, Switching frequency and Ambient temperature.

The drive continuous current value to be used is the factory setting read in PAR **488 Drive cont current**.

When this threshold is exceeded by a percentage set in parameter **982 Current thr hyster**, parameter **986 Current thr mon** is enabled. The signal is disabled when motor speed falls below the threshold.

If the threshold value is lower than the value set in **982 Current thr hyster**, the result produced is always 0. The value set in this parameter is active in both directions of rotation.

Menu	PAR	Description	UM	Type	FB BIT	Def	Min	Max	Acc	Mod
10.15	982	Current thr hyster	perc	UINT16		0	0	100	RW	VS

Setting of the current threshold. A value of 100% corresponds to the value of the drive continuous current, displayed in parameter **488 Drive cont current**, when no derating of the drive continuous current has been activated due to any modification of Mains voltage, Switching frequency and Ambient temperature.

The drive continuous current value to be used is the factory setting read in PAR 488 **Drive cont current**.

When this threshold is exceeded by a percentage set in parameter 982 **Current thr hyster**, parameter 986 **Current thr mon** is enabled. The signal is disabled when motor speed falls below the threshold.

If the threshold value is lower than the value set in **982 Current thr hyster**, the result produced is always 0.

The value set in this parameter is active in both directions of rotation.

11 – COMMANDS

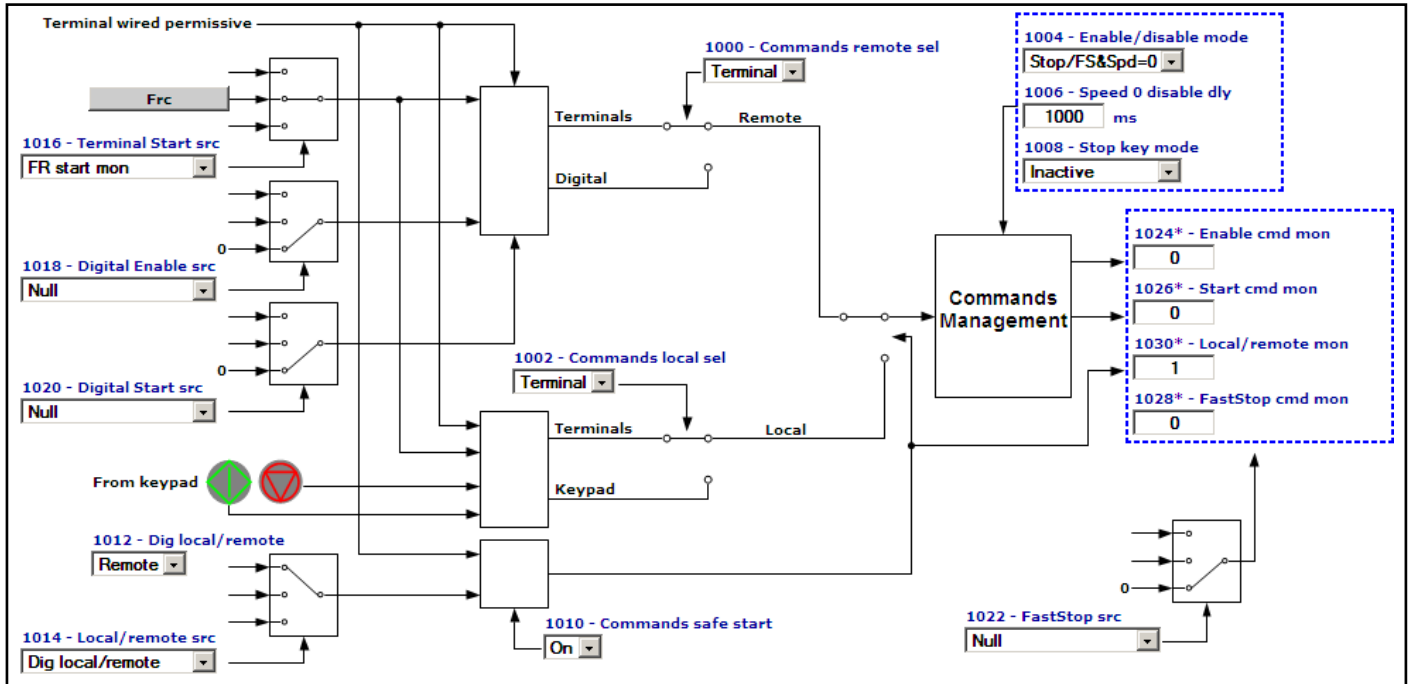

It is possible to work in **Local** or **Remote** mode.

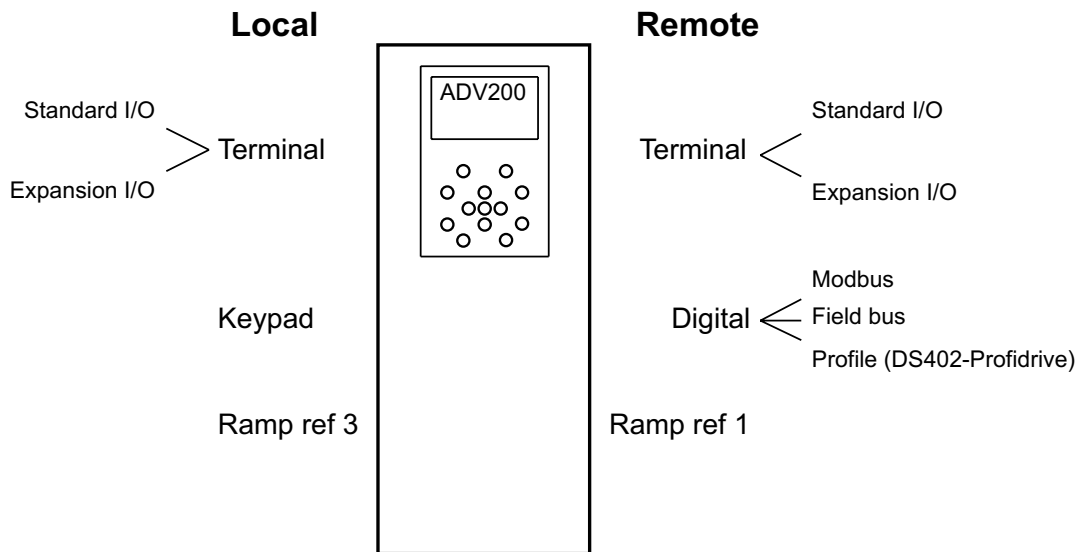

When switching between **Remote** and **Local** modes the origin of the Enable and Start commands is switched and in the **Ramp Ref** block, switching occurs between Ramp ref 1 and Ramp ref 3.

In **Remote** mode the “**Commands remote sel**” parameter is used to configure the source of the Enable and Start commands which can be **Terminal** (standard digital input, expansion digital input) or **Digital** (Modbus, Fieldbus, Profile DS402, Profile profidrive).

In **Local** mode the “**Commands local sel**” parameter is used to configure the source of the Enable and Start commands, which can be **Terminal** (standard digital input, expansion digital input) or **Keypad** (Start key, Stop key).

In **Remote** ⇌ **Digital** mode the **Digital Enable src** and **Digital Start src** parameters must be used to configure the source.

Normally the sources are the Pad parameters. Modbus or Fieldbus must therefore write the desired value on the Pad parameters. Alternatively, the value of 6000 can be written directly on the **Digital Enable src** and **Digital Start src** parameters for a source of Null (0) or the value of 6002 for a source of One (1).

Another alternative is to configure the **Digital Enable src** and **Digital Start src** sources on the **BitX decomp mon** parameters, so that the Modbus or Fieldbus can then write the desired value on the **Dig word decomp** parameter.

Local ↔ **Remote** switching is performed with the variable value configured as **Loc/Remote src**, i.e. it can be a standard digital input, expansion digital input, Modbus, Fieldbus, **Dig Local/Remote**.

In the default condition, the associated variable is **Dig Local/Remote**, which is written by the **LOC** key from the keypad: switching is thus performed by pressing the **LOC** key.

For safety reasons, **Local** ↔ **Remote** switching is only performed with **Terminal Enable = 0**.

Example 1

With the machine in automatic operating mode, the drive works in Remote -> Digital -> Fieldbus mode.

With the machine in manual operating mode, the drive works in Local -> Terminal -> Standard digital input mode.

If switching from automatic to manual machine operation, the drive must switch between Remote and Local mode. The switch command must be sent via standard digital input or fieldbus.

Example 2

With the machine controlled from console A, the drive operates in Local -> Terminal -> Standard digital input mode.

With the machine controlled from console B, the drive operates in Remote -> Digital -> Expansion digital input mode.

When switching the control console, the drive must switch between Remote and Local mode. The switch command must be sent via Standard digital input or Expansion digital input.

This configuration is allowed because the Terminal variables are available in the digital command selection lists.

Menu	PAR	Description	UM	Type	FB BIT	Def	Min	Max	Acc	Mod
11.1	1000	Commands remote sel		ENUM		Terminals	0	1	RWZ	VS

This parameter defines the source of the command signals when the drive is used in the Remote mode.

The Enable command can only be set via hardware, connecting a positive voltage (+24VDC) to terminal 7.

0 Terminals

1 Digital

When the parameter is set to **Terminals** the source of the **Enable cmd mon** command is the **Enable** terminal (7) and the origin of the **Start cmd mon** command is configured using the **Terminal Start src** parameter.

When the parameter is set to **Digital** the origin of the **Enable cmd mon** command is configured using the **Digital Enable src** parameter and the origin of the **Start cmd mon** command is configured using the **Digital Start src** parameter.

If **Digital** is set to generate the **Enable cmd mon** command, as well as the variable associated with **Digital Enable src**, the enable hardware command must also be sent to the **Enable** terminal.

Menu	PAR	Description	UM	Type	FB BIT	Def	Min	Max	Acc	Mod
11.2	1002	Commands local sel		ENUM		Keypad	0	2	ERWZ	VS

This parameter defines the source of the command signals when the drive is used in the **Local** mode.

0 Terminals

2 Keypad

When the parameter is set to **Terminals** the source of the **Enable cmd mon** command is the **Enable** terminal (7) and the origin of the **Start cmd mon** command is configured using the **Terminal Start src** parameter.

When the parameter is set to **Keypad** the origin of the **Enable cmd mon** and **Start cmd mon** commands is the Start key. When **Keypad** is set to generate the **Enable cmd mon** command, as well as the Start key the enable hardware command must also be sent to the **Enable** terminal (7).

Menu	PAR	Description	UM	Type	FB BIT	Def	Min	Max	Acc	Mod
11.3	1004	Enable/disable mode		ENUM		Stop/FS&Spd=0	0	3	ERW	VS

This parameter is used to define the generation of **Enable cmd mon**, i.e. to configure the type of control used for enabling and disabling the drive.

- 0 Off
- 1 Stop/FS&Spd = 0
- 2 Stop&Spd = 0
- 3 FS&Spd = 0

If set to **0 Off**:

In **Terminal** mode the drive is enabled and disabled via the **Enable** terminal.

In **Digital** mode the drive is enabled and disabled when the signal on the **Enable** terminal and the **Digital Enable** command are present simultaneously.

In **Keypad** mode the drive is enabled if the hardware is enabled on the **Enable** terminal and the **Start** key is pressed.

In **Keypad** mode it is disabled if the hardware is not enabled on the **Enable** terminal or if the **Stop** key is pressed twice.

If **1 Stop/FS&Spd = 0** is set:

In **Terminal** mode the drive is enabled when the hardware is enabled on the **Enable** terminal, on the terminal programmed as **Terminal Start** and the **FastStop** terminal must not be enabled.

In **Terminal** mode the drive is instantly disabled if there is no signal on the **Enable** terminal, or when speed=0 is reached if the **Start command** is disabled or the terminal programmed as **FastStop** is enabled.

In **Digital** mode the drive is enabled when the hardware is enabled on the **Enable** terminal, the **Digital Enable**, In **Digital** mode the drive is instantly disabled if there is no signal on the **Enable** terminal, or when speed=0 is reached if the **Digital Start** command is disabled or the terminal programmed as **FastStop** is enabled.

In **Keypad** mode the drive is enabled if the hardware is enabled on the **Enable** terminal and the **Start** key is pressed, with the command disabled on the **FastStop** terminal.

In **Keypad** mode the drive is disabled instantly if the signal is not present on the **Enable** terminal or the **Stop** key is pressed twice.

If **2 Stop&Spd = 0** is set:

In **Terminal** mode the drive is enabled if the hardware is enabled on the **Enable** terminal and the signal is enabled on the terminal programmed as **Terminal Start**.

In **Terminal** mode the drive is instantly disabled if there is no signal on the **Enable** terminal, or if, upon reaching the speed=0, the **Terminal Start** command is disabled.

In **Digital** mode the drive is enabled when the hardware is enabled on the **Enable** terminal and the **Digital Enable** and **DigitalStart** signals are present.

In **Digital** mode the drive is instantly disabled if the signal is not present on the **Enable** terminal, or the **Digital Enable** command is not present, or upon reaching the speed=0 if the **Digital Start** command is set to 0.

In **Keypad** mode the drive is enabled when the hardware is enabled on the **Enable** terminal and the **Start** key is pressed.

In **Keypad** mode the drive is instantly disabled if the signal is not present on the **Enable** terminal or the **Stop** key is pressed twice, or when the speed=0 is reached if the **Stop** key is pressed.

If **3 FS&Spd = 0** is set:

In **Terminal** mode the drive is enabled when the hardware is enabled on the **Enable** terminal and the **Fast-Stop terminal** is not enabled.

In **Terminal** mode the drive is instantly disabled if there is no signal on the **Enable** terminal, or when the speed=0 is reached if the terminal programmed as **FastStop** is enabled.

In **Digital** mode the drive is enabled if the hardware is enabled on the **Enable** terminal and the **Digital Enable** signal is present, with the command on the **FastStop** terminal disabled.

In **Digital** mode the drive is instantly disabled if there is no signal on the **Enable** terminal, or no **Digital Enable** command, or when the speed=0 is reached if the **Digital Start** command is set to 0.

In **Keypad** mode the drive is enabled if the hardware is enabled on the **Enable** terminal and the **Start** key is pressed, with the **FastStop** command disabled.

In **Keypad** mode the drive is instantly disabled if there is no signal on the **Enable** terminal or the **Stop** key is pressed twice, or if, when the speed=0 is reached, the terminal programmed as **FastStop** is enabled.

Menu	PAR	Description	UM	Type	FB BIT	Def	Min	Max	Acc	Mod
11.4	1006	Speed 0 disable dly	ms	UINT16		1000	0	10000	ERW	VS

Setting of a delay in milliseconds between reaching the zero speed and disabling the drive when **Enable/Disable mode** is set to a value other than **Off**.

Menu	PAR	Description	UM	Type	FB BIT	Def	Min	Max	Acc	Mod
11.5	1008	Stop key mode		ENUM		Inactive	0	1	ERW	VS

Setting of the stop key functioning on the keypad in case of Remote->Terminal or Remote->Digital or Local->Terminal mode. In Local -> Keypad mode this configuration is ineffective.

0 Inactive

1 EmgStop&Alarm

If the command is set to **Inactive**, pressing the Stop key on the keypad is ineffective.

If the command is set to **EmgStop&Alarm**, when the Stop key is pressed the motor stops in FastStop mode and the **Emg stop alarm** is generated. When the motor reaches the speed=0, the drive is automatically disabled and waits for the **Fault reset** command. The **Fault reset** command must be sent twice to reset the drive.

Menu	PAR	Description	UM	Type	FB BIT	Def	Min	Max	Acc	Mod
11.6	1010	Commands safe start		BIT		1	0	1	ERW	VS

This parameter is used to define whether the safe start command is disabled or enabled at drive power-on.

0 Off

1 On

If set to **Off**, the safe start command is disabled. If the drive is powered-on with the hardware enabled on the **Enable** terminal, the motor could start rotating.

When set to **On**, the safe start command is enabled. If the drive is powered-on with the hardware enabled on the **Enable** terminal, the motor will not rotate. To set the drive to accept subsequent commands, open the hardware enabling contact on the **Enable** terminal and then close it again.

Menu	PAR	Description	UM	Type	FB BIT	Def	Min	Max	Acc	Mod
11.7	1012	Dig local/remote		ENUM	16	Remote	0	1	ERW	VS

Setting **Local** or **Remote** operating mode.

0 Local

1 Remote

Writing this parameter is only effective if it is associated with **Local/Remote src** and if performed without the hardware enabled on the **Enable** terminal. Press LOC to modify the value of this parameter 0->1.

To disable the LOC key, set **Local/Remote src** to a value other than **Dig local/remote**.

Menu	PAR	Description	UM	Type	FB BIT	Def	Min	Max	Acc	Mod
11.8	1014	Local/remote src		LINK	16	1012	0	16384	ERW	VS

Selection of the origin (source) of the signal that switches between **Remote** and **Local**. Switching can only be

performed if the hardware is not enabled on the **Enable** terminal.

The signal to be associated with this function can be selected from the “**L_DIGSEL3**” selection list.

- 0 Local
- 1 Remote

In **Remote** mode the “**Commands remote sel**” parameter is used to configure the source of the Enable and Start commands, which can be **Terminal** (standard digital input, expansion digital input) or **Digital** (Modbus, Fieldbus, Profile DS402, Profile profdrive).

In **Local** mode the “**Commands local sel**” parameter is used to configure the source of the Enable and Start commands, which can be **Terminal** (standard digital input, expansion digital input) or **Keypad** (Start key, Stop key).

Menu	PAR	Description	UM	Type	FB BIT	Def	Min	Max	Acc	Mod
11.9	1016	Terminal Start src		LINK	16	1048	0	16384	ERW	VS

Selection of the origin (source) of the **Terminal Start** signal. Switching can only be performed if the hardware is not enabled on the **Enable** terminal.

The signal to be associated with this function can be selected from the “**L_DIGSEL3**” selection list.

In the default condition, the origin of the Terminal Start signal is the **Start** output of the ForwardReverseControl (FRC) block.

Menu	PAR	Description	UM	Type	FB BIT	Def	Min	Max	Acc	Mod
11.10	1018	Digital Enable src		LINK	16	6000	0	16384	ERW	VS

Selection of the origin (source) of the signal that defines the enabling of the drive when the commands are sent via serial line or fieldbus. The command to be associated with this function can be selected from the “**L_DIGSEL2**” selection list.

Menu	PAR	Description	UM	Type	FB BIT	Def	Min	Max	Acc	Mod
11.11	1020	Digital Start src		LINK	16	6000	0	16384	ERW	VS

Selection of the origin (source) of the Digital Start signal. The signal to be associated with this function can be selected from the “**L_DIGSEL2**” selection list.

Menu	PAR	Description	UM	Type	FB BIT	Def	Min	Max	Acc	Mod
11.12	1022	FastStop src		LINK	16	6000	0	16384	ERW	VS

Selection of the origin (source) for the fast stop signal (FastStop). The terminal to be associated with this function can be selected from the “**L_DIGSEL2**” selection list. During the execution of the FastStop command the ramps used are **Acceleration time 3** and **Deceleration time 3**.

Menu	PAR	Description	UM	Type	FB BIT	Def	Min	Max	Acc	Mod
11.13	1024	Enable cmd mon		BIT	16	0	0	1	R	VS

The status of the enable command is displayed.

Menu	PAR	Description	UM	Type	FB BIT	Def	Min	Max	Acc	Mod
11.14	1026	Start cmd mon		BIT	16	0	0	1	R	VS

The status of the Start command is displayed.

Menu	PAR	Description	UM	Type	FB BIT	Def	Min	Max	Acc	Mod
11.15	1028	FastStop cmd mon		BIT	16	0	0	1	R	VS

This parameter is used to display the value of the FastStop command state.

Menu	PAR	Description	UM	Type	FB BIT	Def	Min	Max	Acc	Mod
11.16	1040	FR mode		ENUM		Normal	0	2	ERWZ	VS

Setting of the operating mode of the Forward Reverse Control (FRC) block.

- 0 Normal
- 1 Two wire Two wire control
- 2 Three wire Three wire control

The default use of the FRC block is shown below.

The Start command is linked to the Start terminal and the Reverse command is linked to Ramp ref invert.

The function diagrams of the 3 modes are shown below.

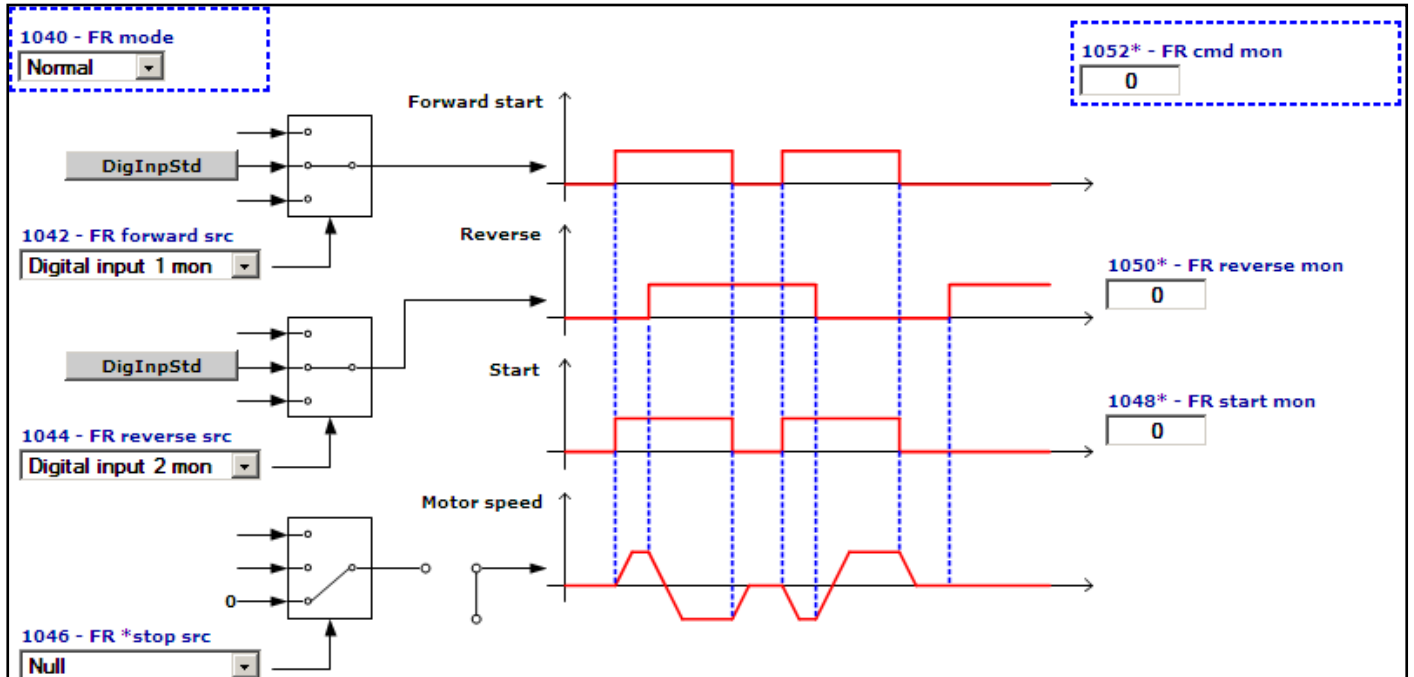

When **0 - Normal** control is set the motor only starts rotating when the **FR Forward** command is sent. If the **FR Reverse** command is present the motor rotates in the reverse direction,

The **FR start mon** output repeats the status of the **FR Forward** command, while the **FR reverse mon** output repeats the status of the **FR Reverse** command.

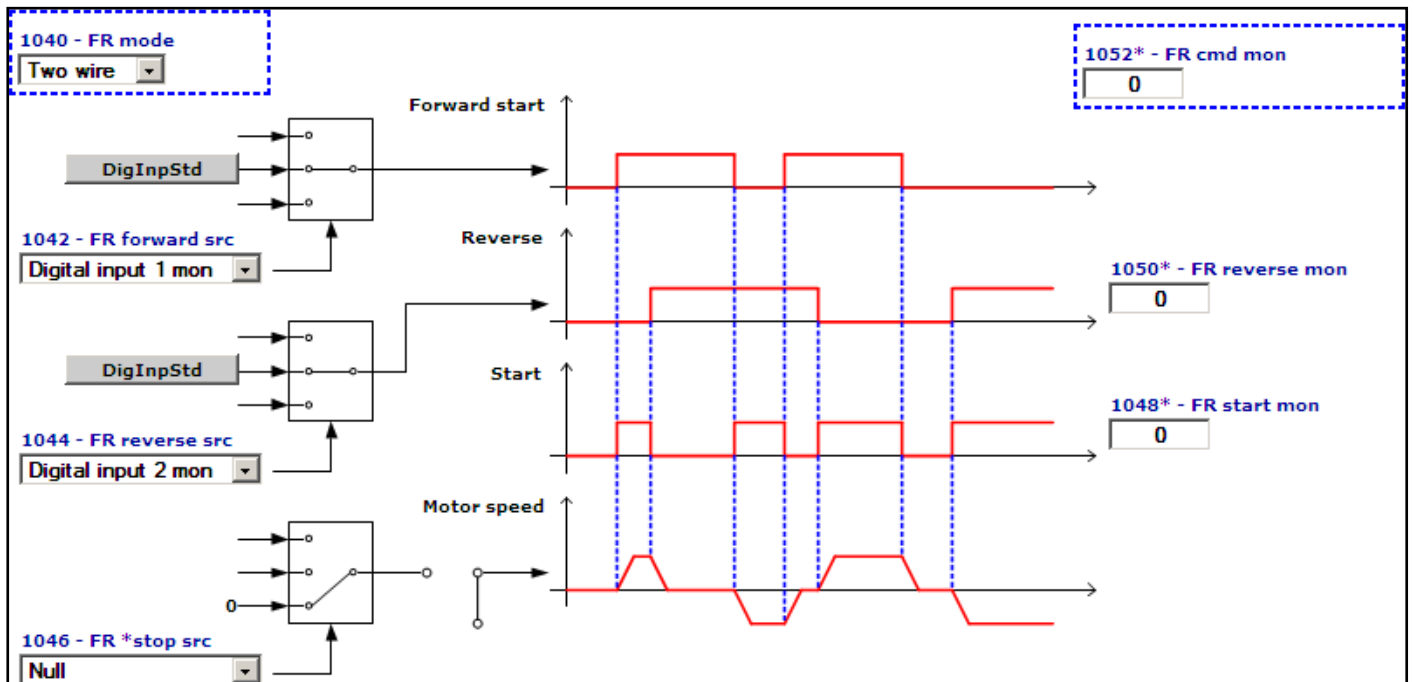

When set to **1 - Two wire** control, the motor only rotates if the **FR Forward** command or **FR Reverse** command is present. The simultaneous presence of the **FR Forward** and **FR Reverse** commands causes the motor to stop.

The **FR start mon** output is enabled if the **FR Forward** and **FR Reverse** commands are not present simultaneously.

The **FR reverse mon** output repeats the status of the **FR Reverse** command.

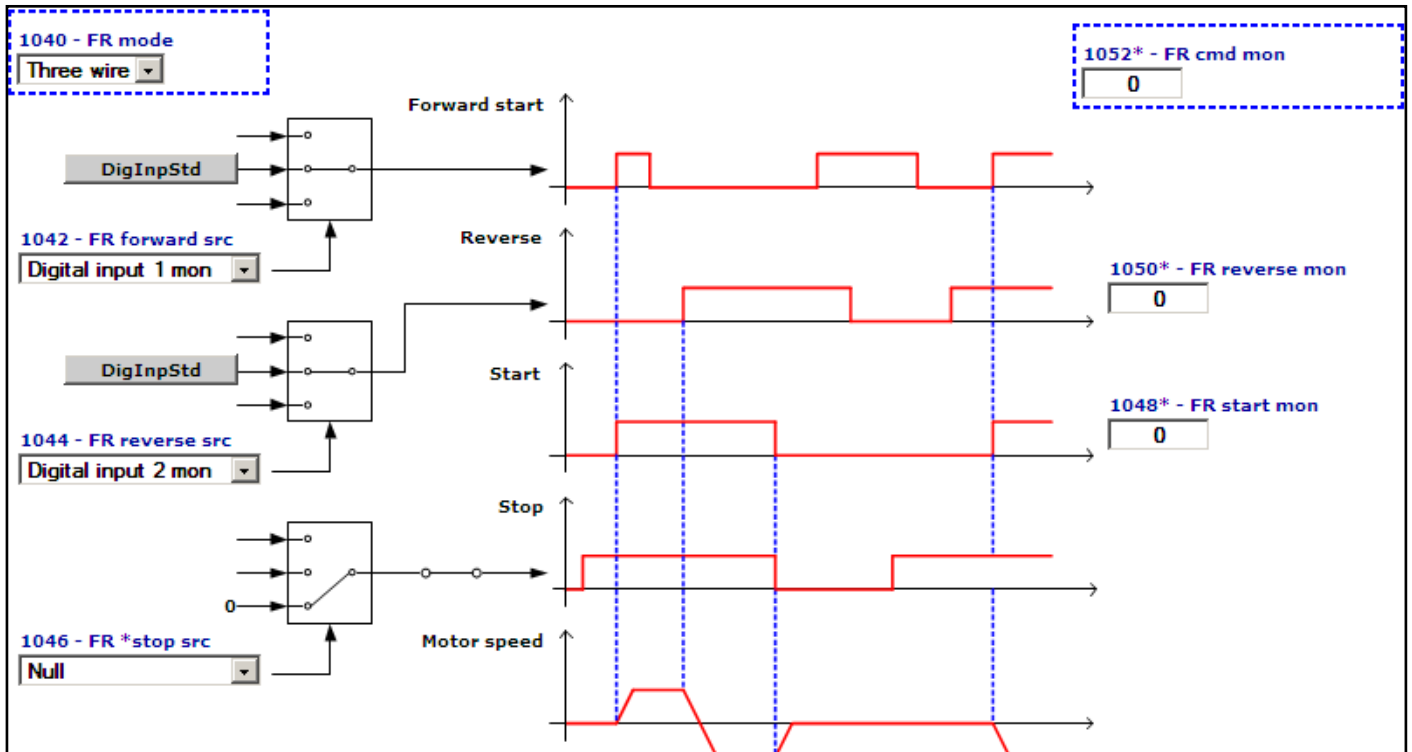

For **2 - Three wire** control the **FR *stop** command must be present on a digital input programmed via the **FR *stop src** parameter (not present in the default condition). When set to **Three wire** control, the motor starts upon receiving an impulse of not less than 50 msec on the **FR Forward** terminal. Once the motor has started the command is no longer necessary on the **FR Forward** terminal. To reverse the direction of rotation enable the **FR Reverse** command: the motor will be brought to the zero speed with the set ramp and will restart in the opposite direction of rotation. The motor rotates in the **Reverse** direction for as long as the **FR Reverse** signal is enabled. If the **FR Reverse** signal is disabled the motor rotates in the **Forward** direction. To stop the motor open the **FR *stop** contact.

Menu	PAR	Description	UM	Type	FB BIT	Def	Min	Max	Acc	Mod
11.17	1042	FR forward src		LINK	16	1112	0	16384	ERW	VS

Selection of the origin (source) for the FR forwardstart signal. With this command the motor starts to rotate (with the **Enable** command enabled). The terminal to be associated with this function can be selected from the “**L_DIGSEL2**” selection list.

Menu	PAR	Description	UM	Type	FB BIT	Def	Min	Max	Acc	Mod
11.18	1044	FR reverse src		LINK	16	1114	0	16384	ERW	VS

Selection of the origin (source) for the FR reverse signal. With this command the motor reverses the direction of rotation (with the **Enable** command enabled). The terminal to be associated with this function can be selected from the “**L_DIGSEL2**” selection list.

Menu	PAR	Description	UM	Type	FB BIT	Def	Min	Max	Acc	Mod
11.19	1046	FR *stop src		LINK	16	6000	0	16384	ERW	VS

Selection of the origin (source) for the FR stop signal. The terminal to be associated with this function can be selected from the “**L_DIGSEL2**” selection list.

Menu	PAR	Description	UM	Type	FB BIT	Def	Min	Max	Acc	Mod
11.20	1048	FR start mon		BIT	16	0	0	1	ER	VS

The status of the Start output of the **Forward Reverse Control (FRC)** block is displayed.

- 0 Stop
- 1 Start

Menu	PAR	Description	UM	Type	FB BIT	Def	Min	Max	Acc	Mod
11.21	1050	FR reverse mon		BIT	16	0	0	1	ER	VS

The status of the Reverse output of the **Forward Reverse Control (FRC)** block is displayed.

- 0 No Reverse
- 1 Reverse

Menu	PAR	Description	UM	Type	FB BIT	Def	Min	Max	Acc	Mod
11.22	1052	FR cdm mon		UINT16		0	0	0	ER	VS

The status of the commands of the **Forward Reverse Control (FRC)** block are displayed.

FR *stop src	FR reverse src	FR forward src	FR cdm mon
0	0	0	0
0	0	1	1
0	1	0	2
0	1	1	3
1	0	0	4
1	0	1	5
1	1	0	6
1	1	1	7

12 – DIGITAL INPUTS

Note: The numbering and description of the following parameters may change if an MDPLc application is active.

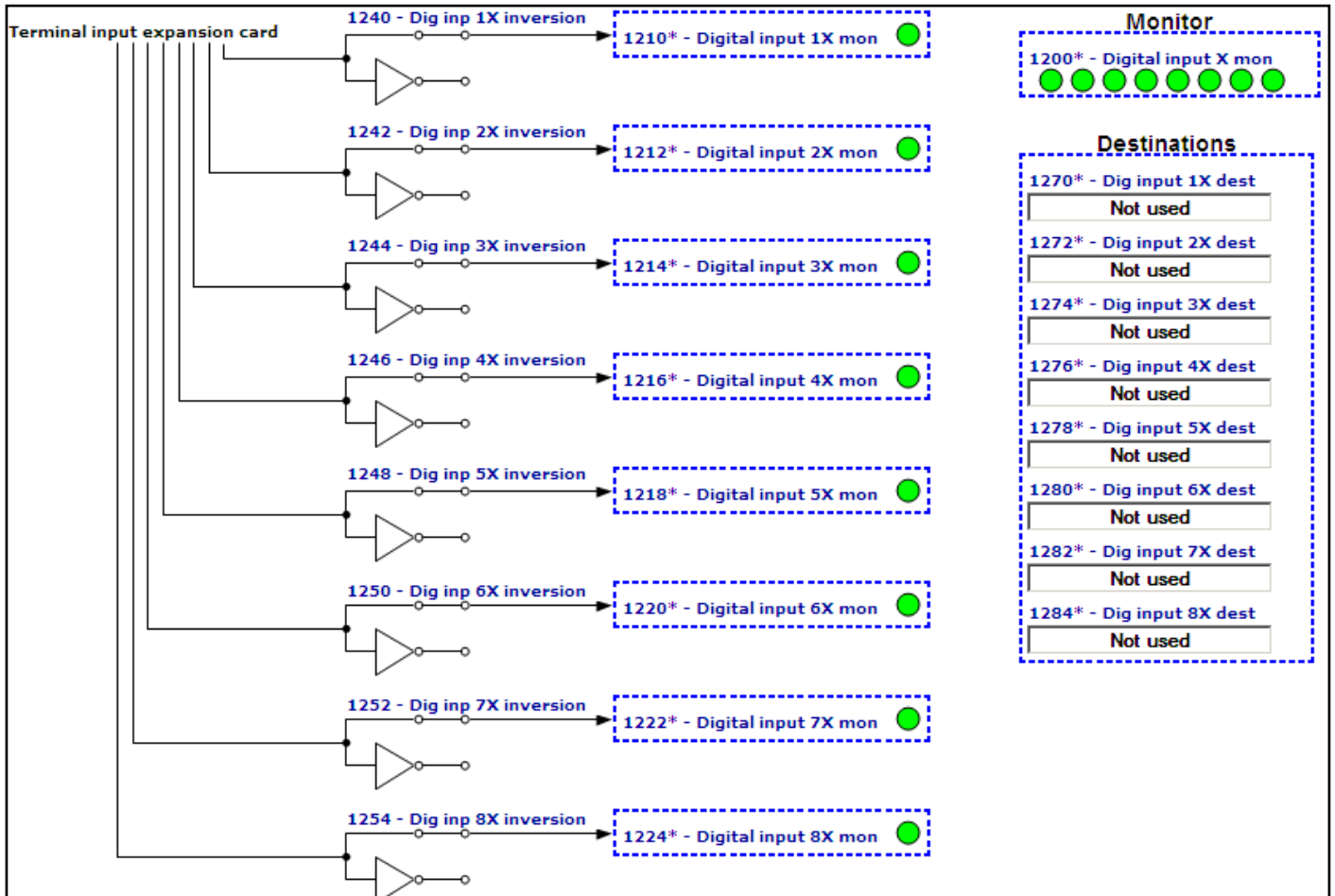
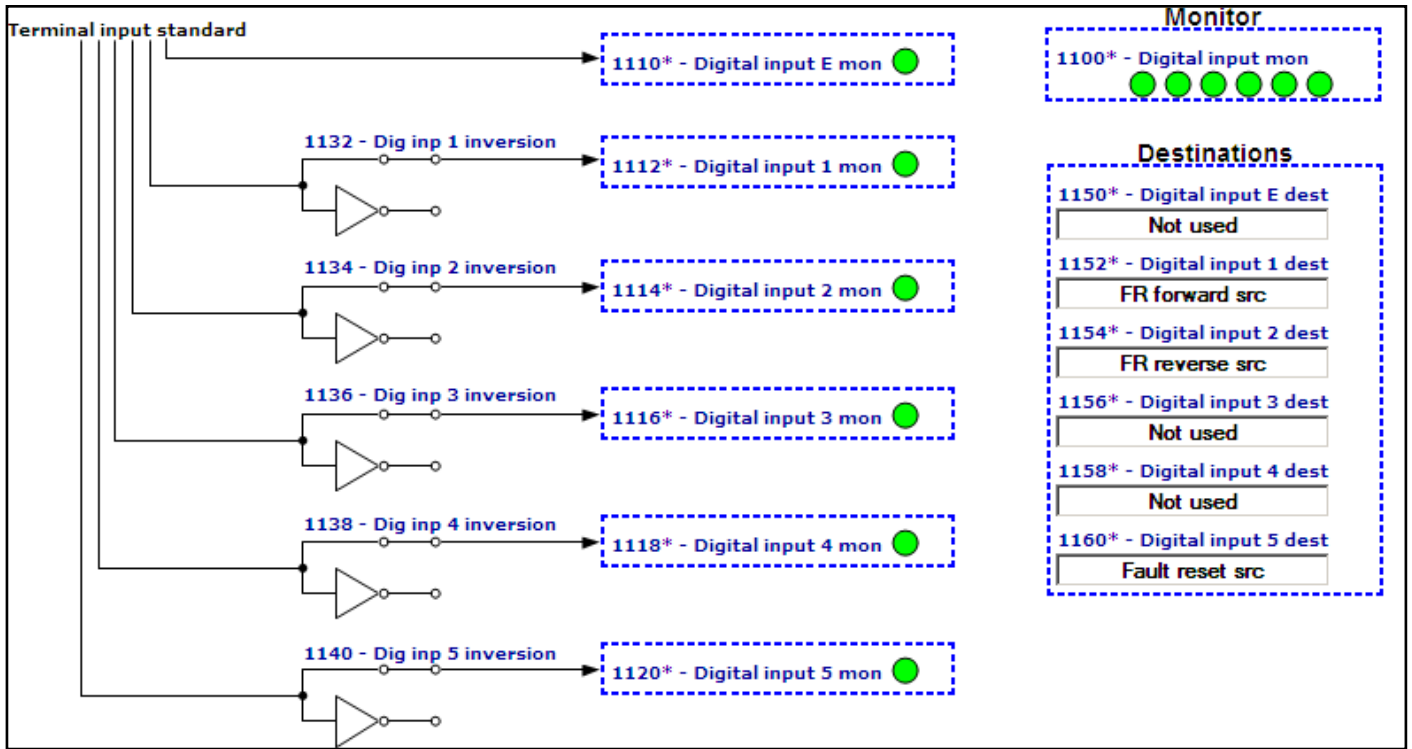

Menu	PAR	Description	UM	Type	FB BIT	Def	Min	Max	Acc	Mod
12.1	1132	Dig inp 1 inversion		BIT		0	0	1	RW	VS
12.2	1134	Dig inp 2 inversion		BIT		0	0	1	RW	VS
12.3	1136	Dig inp 3 inversion		BIT		0	0	1	RW	VS
12.4	1138	Dig inp 4 inversion		BIT		0	0	1	RW	VS
12.5	1140	Dig inp 5 inversion		BIT		0	0	1	RW	VS

Reversal of the logic status of the function associated with the digital input (e.g. from enabled with +24V signal to enabled with low signal).

Menu	PAR	Description	UM	Type	FB BIT	Def	Min	Max	Acc	Mod
12.6	1150	Digital input E dest		ILINK		0	0	0	ER	VS
12.7	1152	Digital input 1 dest		ILINK		0	0	0	ER	VS
12.8	1154	Digital input 2 dest		ILINK		0	0	0	ER	VS
12.9	1156	Digital input 3 dest		ILINK		0	0	0	ER	VS
12.10	1158	Digital input 4 dest		ILINK		0	0	0	ER	VS
12.11	1160	Digital input 5 dest		ILINK		0	0	0	ER	VS

The function to which the associated digital input refers is displayed.

Menu	PAR	Description	UM	Type	FB BIT	Def	Min	Max	Acc	Mod
12.12	1240	Dig inp 1X inversion		BIT		0	0	1	RW	VS
12.13	1242	Dig inp 2X inversion		BIT		0	0	1	RW	VS
12.14	1244	Dig inp 3X inversion		BIT		0	0	1	RW	VS
12.15	1246	Dig inp 4X inversion		BIT		0	0	1	RW	VS
12.16	1248	Dig inp 5X inversion		BIT		0	0	1	RW	VS
12.17	1250	Dig inp 6X inversion		BIT		0	0	1	RW	VS
12.18	1252	Dig inp 7X inversion		BIT		0	0	1	RW	VS
12.19	1254	Dig inp 8X inversion		BIT		0	0	1	RW	VS

Reversal of the logic status of the function associated with the digital input of the expansion card.

Menu	PAR	Description	UM	Type	FB BIT	Def	Min	Max	Acc	Mod
12.20	1270	Dig input 1X dest		ILINK		0	0	0	ER	VS
12.21	1272	Dig input 2X dest		ILINK		0	0	0	ER	VS
12.22	1274	Dig input 3X dest		ILINK		0	0	0	ER	VS
12.23	1276	Dig input 4X dest		ILINK		0	0	0	ER	VS
12.24	1278	Dig input 5X dest		ILINK		0	0	0	ER	VS
12.25	1280	Dig input 6X dest		ILINK		0	0	0	ER	VS
12.26	1282	Dig input 7X dest		ILINK		0	0	0	ER	VS
12.27	1284	Dig input 8X dest		ILINK		0	0	0	ER	VS

Selection of the destination of the associated digital input of the expansion card.

13 – DIGITAL OUTPUTS

Note: The numbering and description of the following parameters may change if an MDPLc application is active.

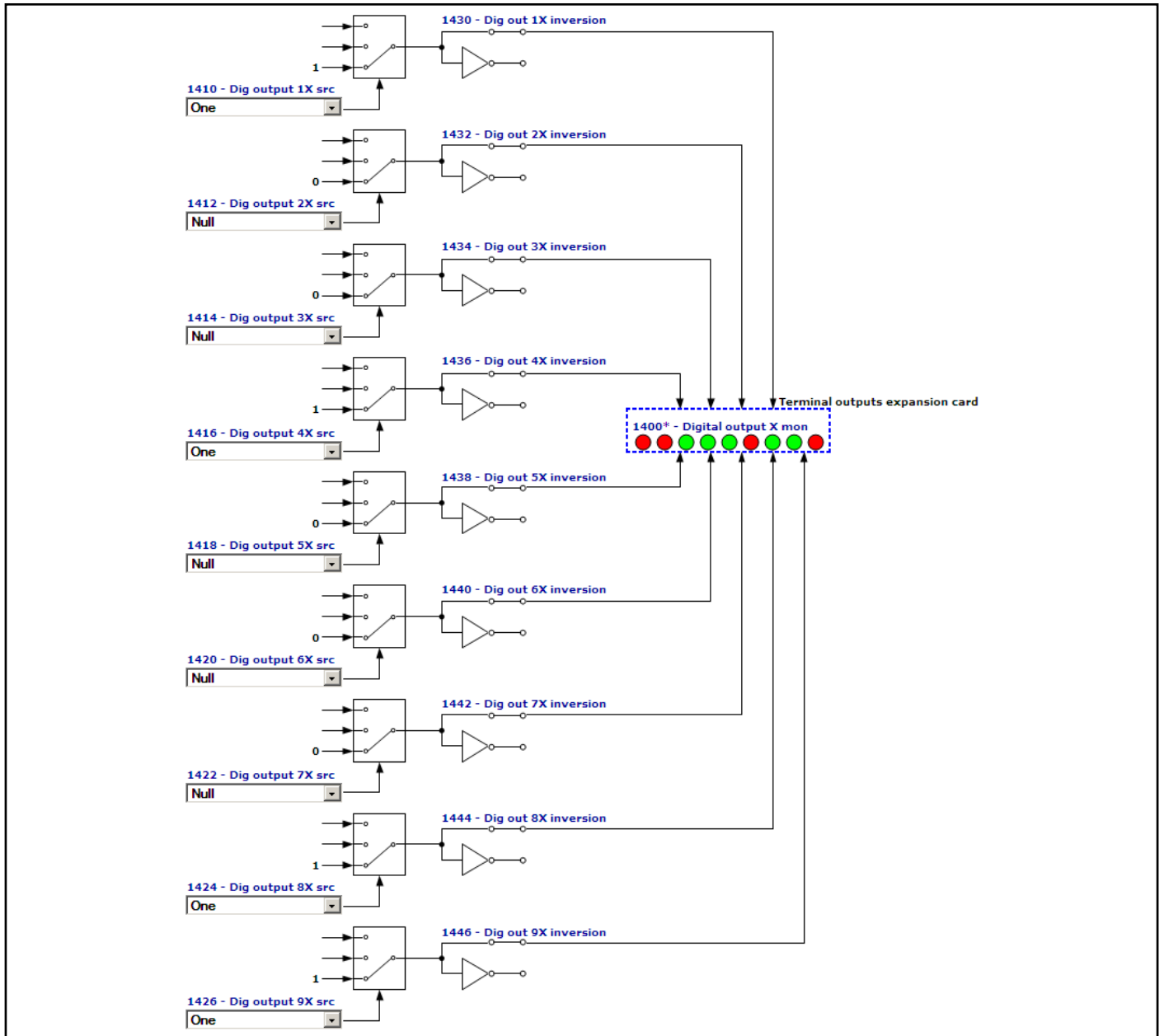
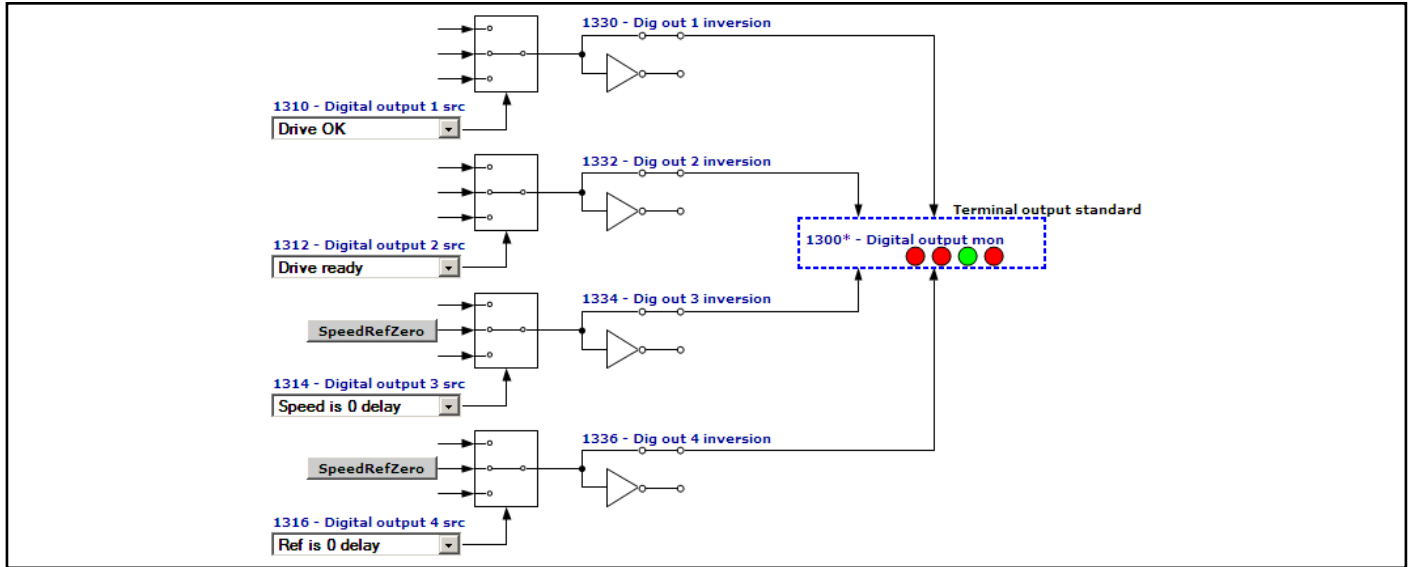

Menu	PAR	Description	UM	Type	FB BIT	Def	Min	Max	Acc	Mod
13.1	1310	Digital output 1 src		LINK	16	1062	0	16384	RW	VS
13.2	1312	Digital output 2 src		LINK	16	1064	0	16384	RW	VS
13.3	1314	Digital output 3 src		LINK	16	946	0	16384	RW	VS
13.4	1316	Digital output 4 src		LINK	16	936	0	16384	RW	VS

Selection of the origin (source) of the signal to be assigned to the relative digital output. The functions that can be associated with the digital outputs are listed in the “L_DIGSEL1” selection list.

Menu	PAR	Description	UM	Type	FB BIT	Def	Min	Max	Acc	Mod
13.5	1330	Dig out 1 inversion		BIT		0	0	1	RW	VS
13.6	1332	Dig out 2 inversion		BIT		0	0	1	RW	VS
13.7	1334	Dig out 3 inversion		BIT		0	0	1	RW	VS
13.8	1336	Dig out 4 inversion		BIT		0	0	1	RW	VS

Reversal of the logic status of the function associated with the digital output.

Menu	PAR	Description	UM	Type	FB BIT	Def	Min	Max	Acc	Mod
13.9	1410	Dig output 1X src		LINK	16	6000	0	16384	RW	VS
13.10	1412	Dig output 2X src		LINK	16	6000	0	16384	RW	VS
13.11	1414	Dig output 3X src		LINK	16	6000	0	16384	RW	VS
13.12	1416	Dig output 4X src		LINK	16	6000	0	16384	RW	VS
13.13	1418	Dig output 5X src		LINK	16	6000	0	16384	RW	VS
13.14	1420	Dig output 6X src		LINK	16	6000	0	16384	RW	VS
13.15	1422	Dig output 7X src		LINK	16	6000	0	16384	RW	VS
13.16	1424	Dig output 8X src		LINK	16	6000	0	16384	RW	VS
13.17	1426	Dig output 9X src		LINK	16	6000	0	16384	RW	VS

Selection of the origin (source) of the signal to be assigned to the relative digital output of the expansion card. The functions that can be associated with the digital outputs are listed in the “L_DIGSEL1” selection list.

Menu	PAR	Description	UM	Type	FB BIT	Def	Min	Max	Acc	Mod
13.18	1430	Dig out 1X inversion		BIT		0	0	1	RW	VS
13.19	1432	Dig out 2X inversion		BIT		0	0	1	RW	VS
13.20	1434	Dig out 3X inversion		BIT		0	0	1	RW	VS
13.21	1436	Dig out 4X inversion		BIT		0	0	1	RW	VS
13.22	1438	Dig out 5X inversion		BIT		0	0	1	RW	VS
13.23	1440	Dig out 6X inversion		BIT		0	0	1	RW	VS
13.24	1442	Dig out 7X inversion		BIT		0	0	1	RW	VS
13.25	1444	Dig out 8X inversion		BIT		0	0	1	RW	VS
13.26	1446	Dig out 9X inversion		BIT		0	0	1	RW	VS

Reversal of the logic status of the function associated with the digital output of the expansion card.

14 – ANALOG INPUTS

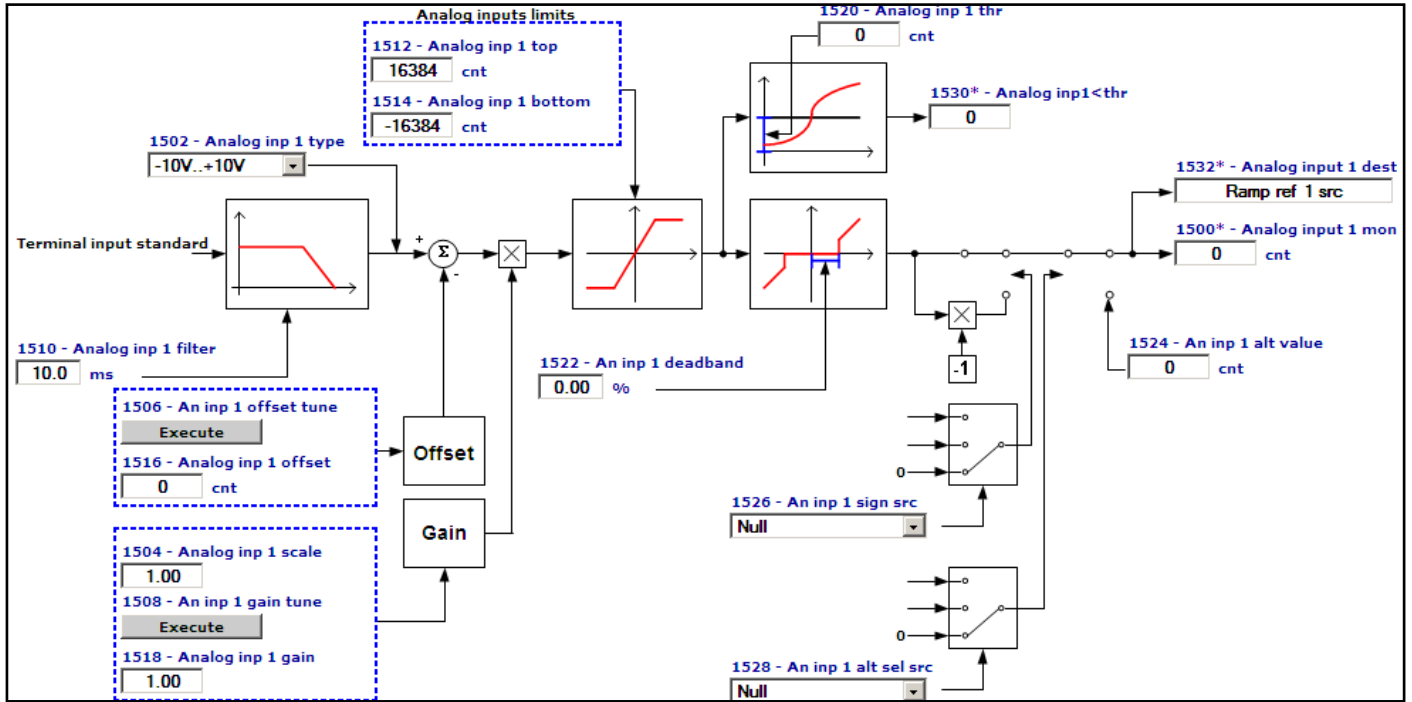

Menu	PAR	Description	UM	Type	FB BIT	Def	Min	Max	Acc	Mod
14.1	1500	Analog input 1 mon	cnt	INT16	16/32	0	0	0	R	VS
14.17	1550	Analog input 2 mon	cnt	INT16	16/32	0	0	0	R	VS

The value of the voltage on the output of the function block of the relative analog input is displayed.

Menu	PAR	Description	UM	Type	FB BIT	Def	Min	Max	Acc	Mod
14.2	1502	Analog inp 1 type		ENUM		-10V..+10V	0	2	RW	VS
14.18	1552	Analog inp 2 type		ENUM		-10V..+10V	0	2	RW	VS

Selection of the type of input (voltage or current). Depending on the input signal, move the switches on the regulation card. The factory parameter is inputs set for differential voltage signals ($\pm 10V$).

- 0 -10V...+10V
- 1 0,20mA ... 10V
- 2 4..20mA

Select option **0** in order to connect a maximum voltage of $\pm 12.5V$ (typically $\pm 10V/5mA$) to the analog input concerned. If the signal is used as a reference, reverse the direction of rotation by inverting the voltage polarity.

Select option **1** to connect a max voltage of 12.5V (typically 10V/5mA) or a signal in current from 0 ... 20 mA to the analog input concerned. The signal must be positive.

Select option **2** to connect a current signal of 4...20 mA to the analog input concerned. The signal must be positive.

Menu	PAR	Description	UM	Type	FB BIT	Def	Min	Max	Acc	Mod
14.3	1504	Analog inp 1 scale		FLOAT		1.0	-10.0	10.0	RW	VS
14.19	1554	Analog inp 2 scale		FLOAT		1.0	-10.0	10.0	RW	VS

Setting of a multiplier factor to apply to the relative analog input.

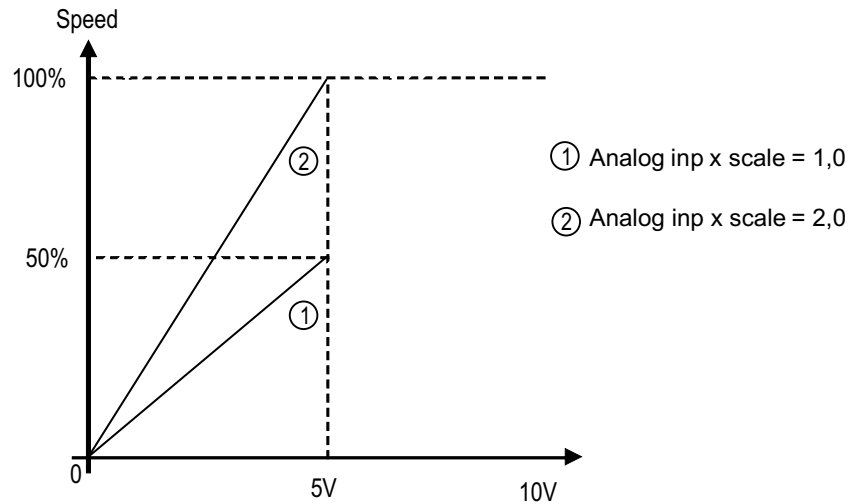

Example:

The speed reference of a drive is assigned with a max external voltage of 5V. With this value the drive must reach the maximum speed allowed (set using **Full scale speed**).

As the **Analog inp x scale** parameter a scale factor of 2 is entered (10V : 5V)

Menu	PAR	Description	UM	Type	FB BIT	Def	Min	Max	Acc	Mod
14.4	1506	An inp 1 offset tune		BIT		0	0	1	RW	VS
14.20	1556	An inp 2 offset tune		BIT		0	0	1	RW	VS

Self-tuning command for the relative analog input offset. Automatic fine tuning of the input. To perform self-tuning, set the input signal to its minimum value and execute the command. The conditions containing an offset can be compensated. When this command is sent, **An inp x offset tune** is automatically selected so that the available input signal corresponds to the zero value of the variable. Offset tuning can also be performed with the drive enabled.

Automatic tuning can only be performed if the following condition is present:

- Input voltage less than 1V or input current less than 2 mA

Note ! The value that is obtained automatically can be changed manually if necessary, using **Analog inp x offset**.

If the voltage setting on the analog input is higher than 1V, the Value too low alarm is generated.

Menu	PAR	Description	UM	Type	FB BIT	Def	Min	Max	Acc	Mod
14.5	1508	An inp 1 gain tune		BIT		0	0	1	RW	VS
14.21	1558	An inp 2 gain tune		BIT		0	0	1	RW	VS

Self-tuning command for the relative analog input gain. Automatic fine tuning of the input. When this command is sent, **Analog inp 1 gain x** is automatically selected so that the available input signal corresponds to the maximum value of the variable. Offset tuning can also be performed with the drive enabled.

Two conditions are necessary in order to perform automatic tuning:

- Input voltage greater than 1V or input current greater than 2 mA
- Positive polarity. The value that is found is automatically accepted for the other direction of rotation.

Note ! If necessary, the value obtained automatically can be changed manually via **Analog inp x gain**.

To perform self-tuning, set the input signal to its maximum value and execute the command. A multiplier factor is calculated to apply to the input signal value (not considering the **Analog inp scale** parameter) to reach the full scale value.

If the voltage setting on the analog input is less than 1V, the Value too low alarm is generated.

Menu	PAR	Description	UM	Type	FB BIT	Def	Min	Max	Acc	Mod
14.6	1510	Analog inp 1 filter	ms	FLOAT		10.0	1.0	1000.0	ERW	VS
14.22	1560	Analog inp 2 filter	ms	FLOAT		10.0	1.0	1000.0	ERW	VS

Filter on the measurement of the corresponding analog input. This parameter can be used to control the response of the analog input and reduce any possible noise and interference.

Menu	PAR	Description	UM	Type	FB BIT	Def	Min	Max	Acc	Mod
14.7	1512	Analog inp 1 top	cnt	INT16		16384	-32768	+32767	ERW	VS
14.23	1562	Analog inp 2 top	cnt	INT16		16384	-32768	+32767	ERW	VS

Setting of the upper speed reference limit as a function of the voltage (or current) of the relative analog reference.

Menu	PAR	Description	UM	Type	FB BIT	Def	Min	Max	Acc	Mod
14.8	1514	Analog inp 1 bottom	cnt	INT16		-16384	-32768	+32767	ERW	VS
14.24	1564	Analog inp 2 bottom	cnt	INT16		-16384	-32768	+32767	ERW	VS

Setting of the lower speed reference limit as a function of the voltage (or current) of the relative analog reference.

Menu	PAR	Description	UM	Type	FB BIT	Def	Min	Max	Acc	Mod
14.9	1516	Analog inp 1 offset	cnt	INT16		0	-32768	+32767	ERW	VS
14.25	1566	Analog inp 2 offset	cnt	INT16		0	-32768	+32767	ERW	VS

Setting of a value to compensate the condition in which the analog signal contains an offset, or when the variable assigned to the input already has a value even though no signal is connected.

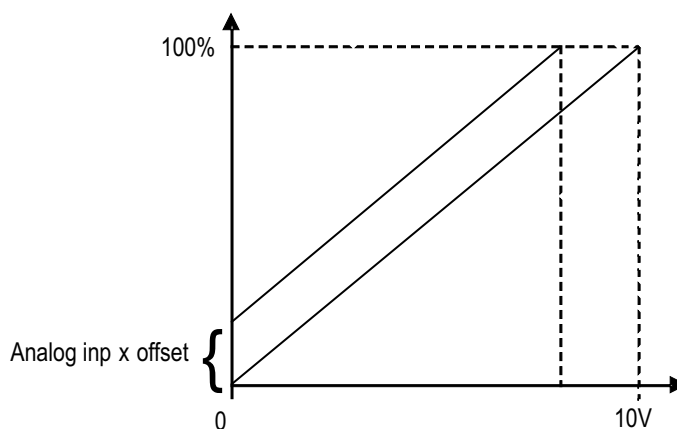

Menu	PAR	Description	UM	Type	FB BIT	Def	Min	Max	Acc	Mod
14.10	1518	Analog inp 1 gain		FLOAT		1.0	-10.0	10.0	ERW	VS
14.26	1568	Analog inp 2 gain		FLOAT		1.0	-10.0	10.0	ERW	VS

This parameter contains the value of the multiplier factor to apply to the analog reference calculated using the **Analog inp gain tune** function.

Example:

An external analog reference only reaches a maximum of 9.8V instead of 10V. 1.020 (10V : 9.8V) is entered as the **Analog inp x gain** parameter.

The same result can be achieved using the **An inp x gain tune** function. This parameter can be selected from the keypad menu. The maximum analog value available (in this case 9.8V) must be present on the terminal, with positive polarity. Press the Enter key on the keypad to start analog reference self-tuning.

Menu	PAR	Description	UM	Type	FB BIT	Def	Min	Max	Acc	Mod
14.11	1520	Analog inp 1 thr		INT16		0	-16384	+ 16383	ERW	VS
14.27	1570	Analog inp 2 thr		INT16		0	-16384	+ 16383	ERW	VS

Setting of the analog input threshold for the **speed not exceeded** signal, which allows enabling of the digital outputs **Analog inp1** (par. 1530) and **Analog inp2** (par.1580).

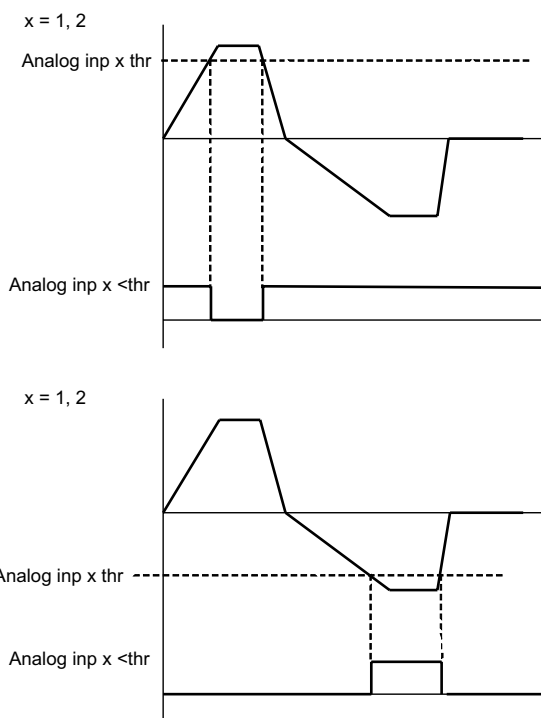

Menu	PAR	Description	UM	Type	FB BIT	Def	Min	Max	Acc	Mod
14.12	1522	An inp 1 deadband	perc	FLOAT		0	0	100.0	ERW	VS
14.28	1572	An inp 2 deadband	perc	FLOAT		0	0	100.0	ERW	VS

Deadband referring to the analog input signal. When the value on the input terminal is below the threshold defined by the parameter, the output signal of the analog input block is forced to zero. Outside the deadband, the block output varies linearly from zero to 100%.

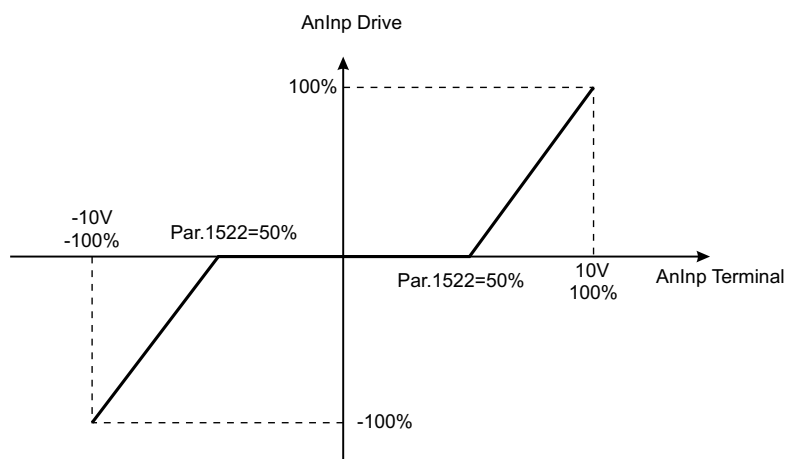

Menu	PAR	Description	UM	Type	FB BIT	Def	Min	Max	Acc	Mod
14.13	1524	An inp 1 alt value	cnt	INT16	16/32	0	-16384	16384	ERW	VS
14.29	1574	An inp 2 alt value	cnt	INT16	16/32	0	-16384	16384	ERW	VS

Setting of a fixed alternative value for the relative analog input, which can be selected via a command enabled by a digital input programmed with the **An inp alt sel src** parameter.

Menu	PAR	Description	UM	Type	FB BIT	Def	Min	Max	Acc	Mod
14.14	1526	An inp 1 sign src		LINK	16	6000	0	16384	ERW	VS
14.30	1576	An inp 2 sign src		LINK	16	6000	0	16384	ERW	VS

Selection of the origin (source) of the signal to be assigned to the relative digital input for selecting the direction of rotation of the motor. The functions that can be associated with the digital outputs are listed in the "L_DIGSEL2" selection list.

Menu	PAR	Description	UM	Type	FB BIT	Def	Min	Max	Acc	Mod
14.15	1528	An inp 1 alt sel src		LINK	16	6000	0	16384	ERW	VS
14.31	1578	An inp 2 alt sel src		LINK	16	6000	0	16384	ERW	VS

Selection of the origin (source) of the signal to be assigned to the relative digital input for selecting the alternative analog reference. The functions that can be associated with the digital outputs are listed in the "L_DIGSEL2" selection list.

Menu	PAR	Description	UM	Type	FB BIT	Def	Min	Max	Acc	Mod
14.16	1532	Analog inp 1 dest		ILINK		0	0	0	ER	VS
14.32	1582	Analog inp 2 dest		ILINK		0	0	0	ER	VS

The function for which the relative analog input has been programmed and on which it acts is displayed.

Menu	PAR	Description	UM	Type	FB BIT	Def	Min	Max	Acc	Mod
14.33	1600	Analog input 1X mon	cnt	INT16	16/32	0	0	0	R	VS
14.44	1650	Analog input 2X mon	cnt	INT16	16/32	0	0	0	R	VS

The value of the voltage output of the function block of the relative analog input is displayed.

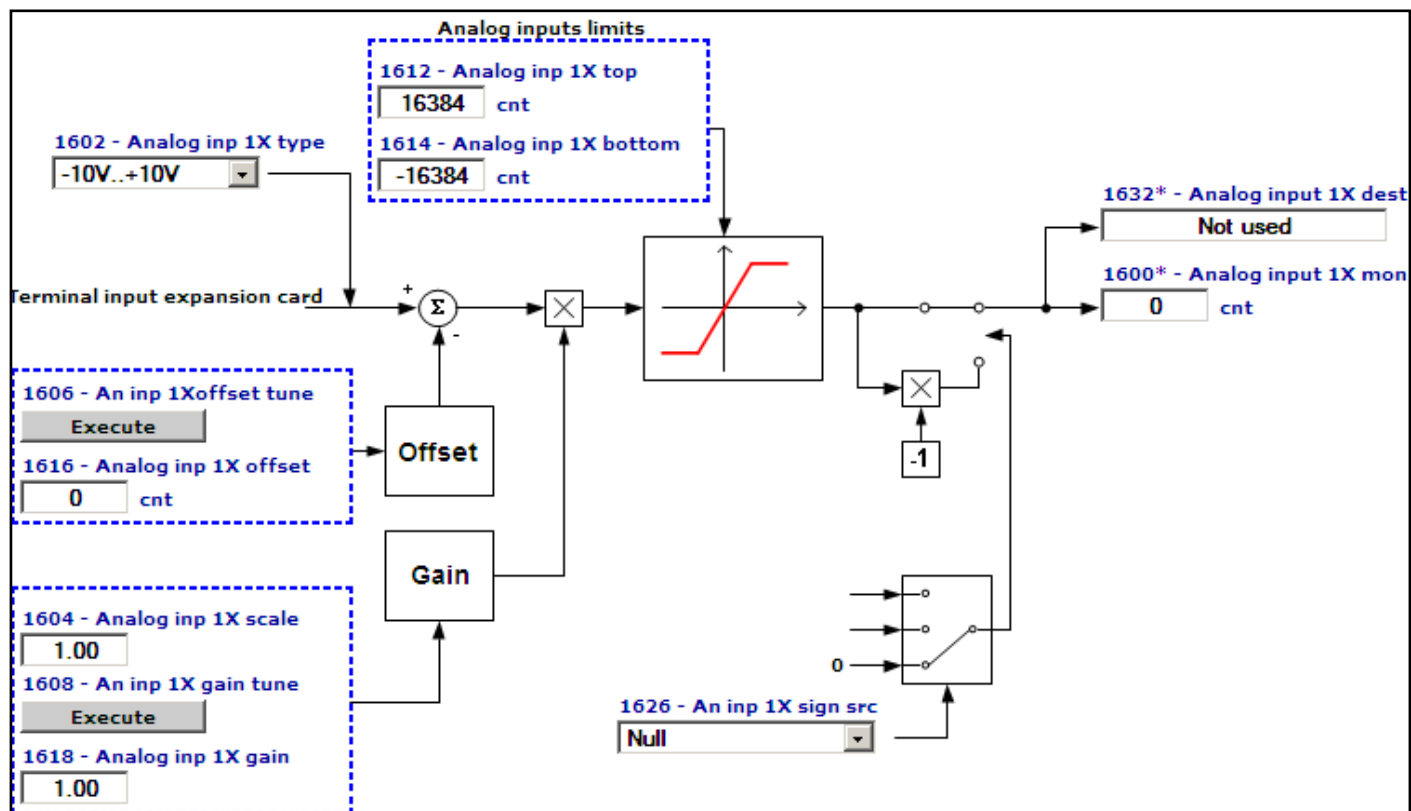

Menu	PAR	Description	UM	Type	FB BIT	Def	Min	Max	Acc	Mod
14.34	1602	Analog inp 1X type		ENUM		-10V..+10V	0	2	RW	VS
14.45	1652	Analog inp 2X type		ENUM		-10V..+10V	0	2	RW	VS

Selection of the type of expansion card input (voltage or current input). In the default configuration the inputs are coded for voltage signals.

- 0 -10V+10V
- 1 0..10V
- 2 4..20mA
- 3 0..20mA
- 4 PT1000
- 5 NI1000
- 6 PT100

Select option **0** in order to connect a maximum voltage of $\pm 12.5V$ (typically $\pm 10V/5mA$) to the analog input concerned. If the signal is used as a reference, reverse the direction of rotation of the drive by inverting the voltage polarity.

Select option **1** to connect a max voltage of 12.5V (typically 10V/5mA). The signal must be positive.

Select option **2** to connect a current signal of 4...20 mA to the analog input concerned. The signal must be positive.

Select **3** to connect a current signal of 0...20 mA to the analog input concerned. The signal must be positive.

Select **4** to connect a signal from a PT1000 probe to the analog input concerned.

Select **5** to connect a signal from an NI1000 probe to the analog input concerned.

Select **6** to connect a signal from a PT1000 probe to the analog input concerned.

Menu	PAR	Description	UM	Type	FB BIT	Def	Min	Max	Acc	Mod
14.35	1604	Analog inp 1X scale		FLOAT		1.0	-10.0	10.0	RW	VS
14.46	1654	Analog inp 2X scale		FLOAT		1.0	-10.0	10.0	RW	VS

Setting of a multiplier factor to apply to the relative analog input of the expansion card.

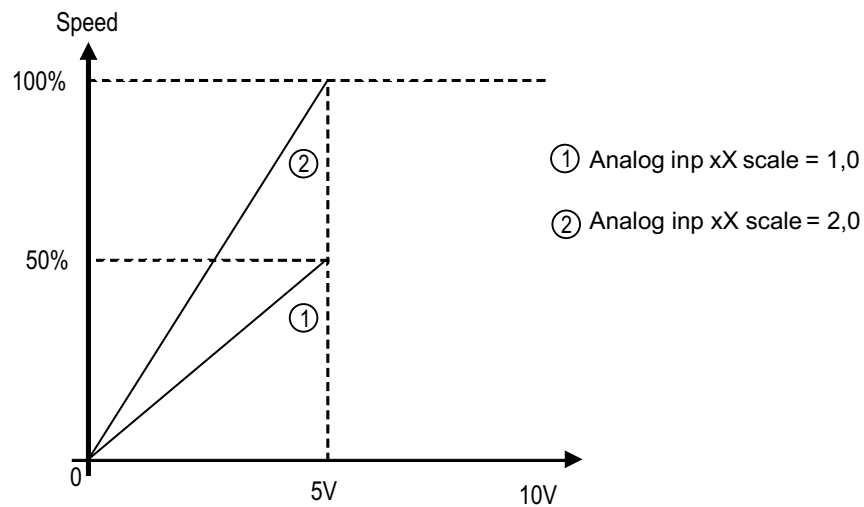

Example:

The speed reference of a drive is assigned with a max external voltage of 5V. With this value the drive must reach the maximum speed allowed (set using **Full scale speed**).

As the **Analog inp X scale** parameter the scale factor of 2 is entered (10V : 5V)

Menu	PAR	Description	UM	Type	FB BIT	Def	Min	Max	Acc	Mod
14.36	1606	An inp 1Xoffset tune		BIT		0	0	1	RWZ	VS
14.47	1656	An inp 2Xoffset tune		BIT		0	0	1	RWZ	VS

Self-tuning command for the offset of the relative analog input of the expansion card. Automatic fine tuning of the input. To perform self-tuning, set the input signal to its minimum value and execute the command. The conditions containing an offset can be compensated. When this command is sent, **An inp xX offset tune** is automatically selected so that the available input signal corresponds to the zero value of the variable.

Automatic tuning can only be performed if the following condition is present:

- Input voltage less than 1V or input current less than 2 mA

Note ! The value that is obtained automatically can be changed manually, if necessary, using **An inp offset xX**.

If the voltage setting on the analog input is higher than 1V, the Value too low alarm is generated.

Menu	PAR	Description	UM	Type	FB BIT	Def	Min	Max	Acc	Mod
14.37	1608	An inp 1X gain tune		BIT		0	0	1	RWZ	VS
14.48	1658	An inp 2X gain tune		BIT		0	0	1	RWZ	VS

Self-tuning command for the relative analog input gain. Automatic fine tuning of the input. When this command is sent, **Analog inp 1 gain x** is automatically selected so that the available input signal corresponds to the maximum value of the variable.

Two conditions are necessary in order to perform automatic tuning:

- Input voltage greater than 1V or input current greater than 2 mA
- Positive polarity. The value that is found is automatically accepted for the other direction of rotation.

Note ! If necessary, the value obtained automatically can be changed manually via **Analog inp Xx gain**.

To perform self-tuning, set the input signal to its maximum value and execute the command. A multiplier factor is calculated to apply to the input signal value (not considering the **Analog inp scale** parameter) to reach the full scale value.

If the voltage setting on the analog input is less than 1V, the Value too low alarm is generated.

Menu	PAR	Description	UM	Type	FB BIT	Def	Min	Max	Acc	Mod
14.38	1612	Analog inp 1X top	cnt	INT16		16384	-32768	+ 32767	ERW	VS
14.49	1662	Analog inp 2X top	cnt	INT16		16384	-32768	+ 32767	ERW	VS

Setting of the upper speed reference limit as a function of the voltage (or current) of the relative analog reference of the expansion card.

Menu	PAR	Description	UM	Type	FB BIT	Def	Min	Max	Acc	Mod
14.39	1614	Analog inp 1X bottom	cnt	INT16		-16384	-32768	+ 32767	ERW	VS
14.50	1664	Analog inp 2X bottom	cnt	INT16		-16384	-32768	+ 32767	ERW	VS

Setting of the lower speed reference limit as a function of the voltage (or current) of the relative analog reference of the expansion card.

Menu	PAR	Description	UM	Type	FB BIT	Def	Min	Max	Acc	Mod
14.40	1616	Analog inp 1X offset	cnt	INT16		0	-32768	+ 32767	ERW	VS
14.51	1666	Analog inp 2X offset	cnt	INT16		0	-32768	+ 32767	ERW	VS

Setting of an offset value to algebraically add to the relative analog input of the expansion card.

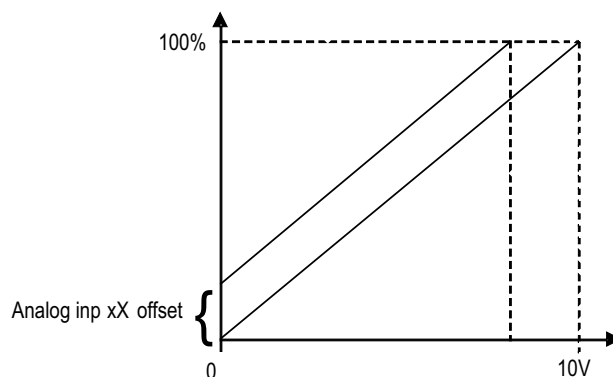

Menu	PAR	Description	UM	Type	FB BIT	Def	Min	Max	Acc	Mod
14.41	1618	Analog inp 1X gain		FLOAT		1.0	-10.0	10.0	ERW	VS
14.52	1668	Analog inp 2X gain		FLOAT		1.0	-10.0	10.0	ERW	VS

This parameter contains the value of the multiplier factor to apply to the analog reference of the expansion card calculated using the **Analog inp gain tune** function.

Example:

An external analog reference only reaches a maximum of 9.8V instead of 10V. 1.020 (10V : 9.8V) is entered as the **Analog inp x gain** parameter.

The same result can be achieved using the **Analog inp x gain tune** function. This parameter can be selected from the keypad menu. The maximum analog value available (in this case 9.8V) must be present on the terminal, with positive polarity. Press the Enter key on the keypad to start analog reference self-tuning.

Menu	PAR	Description	UM	Type	FB BIT	Def	Min	Max	Acc	Mod
14.42	1626	An inp 1X sign src		LINK	16	6000	0	16384	ERW	VS
14.53	1676	An inp 2X sign src		LINK	16	6000	0	16384	ERW	VS

Selection of the origin (source) of the signal to be assigned to the relative digital input of the expansion card for selecting the direction of rotation of the motor. The functions that can be associated with the digital outputs are listed in the "**L_DIGSEL2**" selection list.

Menu	PAR	Description	UM	Type	FB BIT	Def	Min	Max	Acc	Mod
14.43	1632	Analog inp 1X dest		ILINK		0	0	0	ER	VS
14.54	1682	Analog inp 2X dest		ILINK		0	0	0	ER	VS

The function for which the relative analog input of the expansion card has been programmed and on which it acts is displayed.

15 – ANALOG OUTPUTS

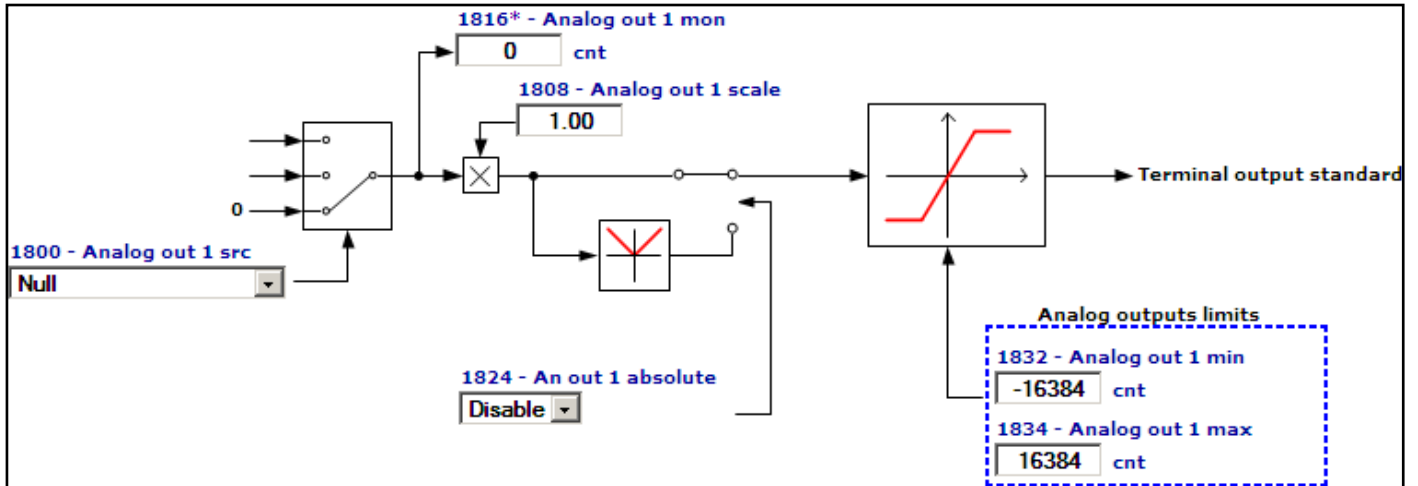

On the ADV regulation card there are two programmable analog outputs.

Analog output 1 supplies a two-pole +/-10VDC voltage signal, while analog output 2 can be programmed to obtain a 0-20mA or 4-20mA output signal in current or a signal in two-pole +/-10VDC voltage, depending on the parameter assigned.

Table: value of the signal of the analog outputs according to the measurement used

PAR	Description	Full scale output
626	Ramp ref out mon	10V = Full scale speed (Par 680)
628	Ramp setpoint	
760	Ramp out mon	
664	Speed setpoint	
260	Motor speed	
262	Motor speed nofilter	
852	Multi ref out mon	
870	Mpot setpoint	
894	Mpot output mon	
920	Jog output mon	
250	Output current	10V = 200% CT drive rated current (this value can be found in the manual and is defined @400Vac, default switching frequency and 40°C)
280	Torque current ref	
282	Magnet current ref	
284	Torque current	
286	Magnet current	
3104	Inertia comp mon	10V = 200% Nominal motor torque
252	Output voltage	10V = 200% Mains voltage (Par 560)
254	Output frequency	10V = 1000Hz
270	DC link voltage	10V = 7000V
3006	Speed ratio out mon	10V = 100%
1500	Analog input 1 mon	10V = 10V Analog input
1550	Analog input 2 mon	
1600	Analog input 1X mon	
1650	Analog input 2X mon	
368	Drive overload accum	5V = 100% Accumulator
3212	Motor overload accum	
3260	Bres overload accum	
2232	Spd reg P gain Inuse	10V = 400%
2234	Spd reg I gain Inuse	
3446	Powerloss nexratio	10V = 50%
4024 ... 4174	Fieldbus M->SX mon	10V = 16384 * 2 ^ 16
3700 ... 3730	Pad X	

Menu	PAR	Description	UM	Type	FB BIT	Def	Min	Max	Acc	Mod
15.1	1800	Analog out 1 src		LINK	16/32	6000	0	16384	RW	VS
15.2	1802	Analog out 2 src		LINK	16/32	6000	0	16384	RW	VS

Selection of the origin (source) of the signals that can be placed as variables on the analog outputs. The functions that can be assigned to the analog outputs are listed in the "L_ANOUT" selection list.

Menu	PAR	Description	UM	Type	FB BIT	Def	Min	Max	Acc	Mod
15.3	1808	Analog out 1 scale		FLOAT		1.0	-10.0	10.0	RW	VS
15.4	1810	Analog out 2 scale		FLOAT		1.0	-10.0	10.0	RW	VS

Parameter for setting a multiplier factor of the signal of the relative analog output. It can be used to amplify or reduce the input value of the relative analog output block.

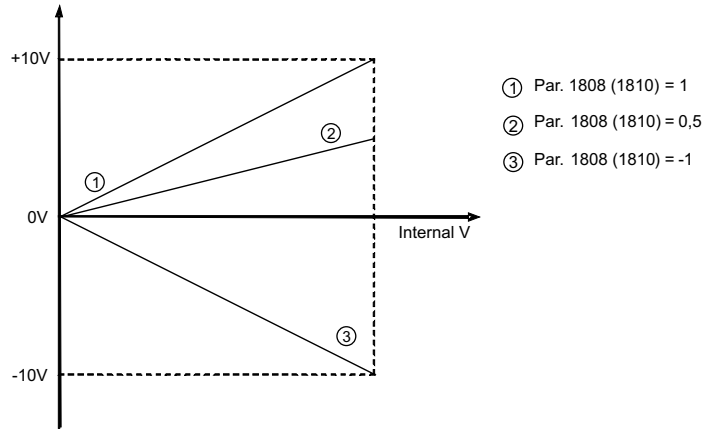

$$V_{out} = 10 \times \left(\frac{\text{Stp Var} \times \text{par. 1808 (1810)}}{\text{FS Var}} \right)$$

where:

- Vout** output voltage on the card terminals.
- Stp Var** actual value of the variable (variable unit)
- SF Var** full scale of the variable (variable unit)

Example of calculation of scale factor **Analog out x scale**

To display the drive speed, use an analog instrument with field of measurement from 0...2V. This means that, to display the speed of the drive, a voltage of 2V on the analog output of the drive must correspond to the maximum speed. With a scale factor equal to 1 a voltage of 10V would correspond to the maximum speed. With a scale factor equal to 0.2 = 2V/10V a voltage of 2V would correspond to the maximum speed.

Menu	PAR	Description	UM	Type	FB BIT	Def	Min	Max	Acc	Mod
15.5	1816	Analog out 1 mon	cnt	INT16		0	0	0	ER	VS

The value of the actual voltage present on analog output 1 is displayed.

Menu	PAR	Description	UM	Type	FB BIT	Def	Min	Max	Acc	Mod
15.6	1818	Analog out 2 mon	cnt	INT16		0	0	0	ER	VS

The value of the actual voltage or current present on analog output 2 is displayed.

Menu	PAR	Description	UM	Type	FB BIT	Def	Min	Max	Acc	Mod
15.7	1824	An out 1 absolute		ENUM		Disable	0	1	ERW	VS
15.8	1826	An out 2 absolute		ENUM		Disable	0	1	ERW	VS

Enables the relative analog output as an absolute value. If this parameter is set to 1 the voltage on the analog output assumes the value of 0 - 10V regardless of the sign of the command signal.

- 0 Disable
- 1 Enable

Menu	PAR	Description	UM	Type	FB BIT	Def	Min	Max	Acc	Mod
15.9	1832	Analog out 1 min	cnt	INT16		-16384	-32768	+32767	ERW	VS
15.10	1834	Analog out 1 max	cnt	INT16		16384	-32768	+32767	ERW	VS

Setting of the minimum and maximum values for the analog output for the voltage present on analog output 1

Menu	PAR	Description	UM	Type	FB BIT	Def	Min	Max	Acc	Mod
15.11	1840	Analog out 2 min	cnt	INT16		-16384	-32768	+32767	ERW	VS
15.12	1842	Analog out 2 max	cnt	INT16		16384	-32768	+32767	ERW	VS

Setting of the minimum and maximum values for the analog output for the voltage present on analog output 2

Menu	PAR	Description	UM	Type	FB BIT	Def	Min	Max	Acc	Mod
15.13	1848	Analog out 2 type		ENUM		-10V..+10V	0	2	ERW	VS

Selection of the type of output (in voltage or current). Depending on the output signal, move the S3 switch on the regulation card. The standard output is coded for the signal in voltage.

- 0 0...20mA
- 1 4...20mA
- 2 -10V..+10V

If set to **0** the analog output sends 0...20mA
 If set to **1** the analog output sends 4...20mA
 If set to **2** the analog output sends -10...+10V

Menu	PAR	Description	UM	Type	FB BIT	Def	Min	Max	Acc	Mod
15.14	1850	Analog out 1X src		LINK	16/32	6000	0	16384	RW	VS
15.15	1852	Analog out 2X src		LINK	16/32	6000	0	16384	RW	VS

Selection of the origin (source) of the signals that can be placed as variables on the analog outputs of the expansion card. The functions that can be assigned to the analog outputs are listed in the "L_ANOUT" selection list.

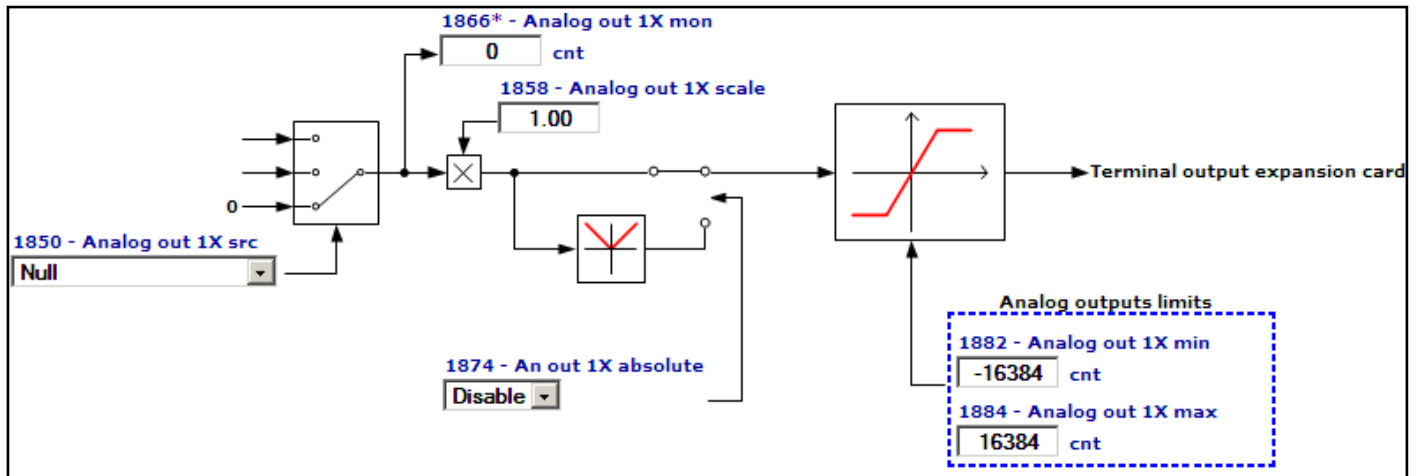

Menu	PAR	Description	UM	Type	FB BIT	Def	Min	Max	Acc	Mod
15.16	1858	Analog out 1X scale		FLOAT		1.0	-10.0	10.0	RW	VS
15.17	1860	Analog out 2X scale		FLOAT		1.0	-10.0	10.0	RW	VS

Parameter for setting a multiplier factor of the signal of the relative analog output of the expansion card. It can be used to amplify or reduce the input value of the relative analog output block.

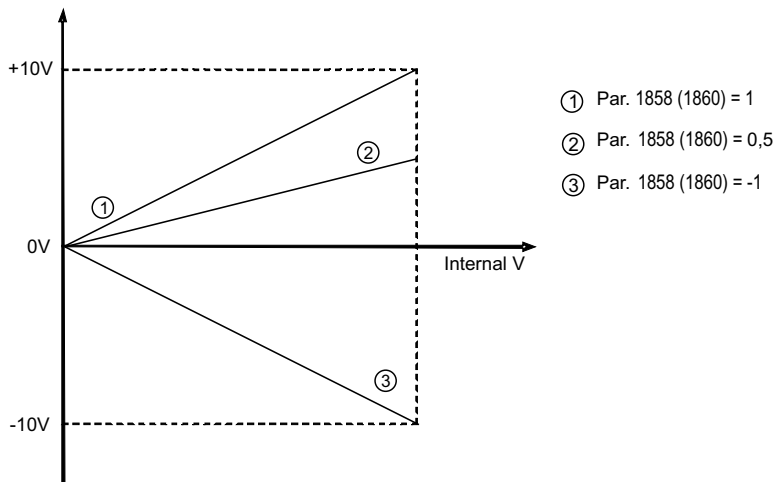

$$V_{out} = 10 \times \left(\frac{\text{Stp Var} \times \text{par. 1858 (1860)}}{\text{FS Var}} \right)$$

where:

- Vout** output voltage on the card terminals.
- Stp Var** actual value of the variable (variable unit)
- SF Var** full scale of the variable (variable unit)

Example of calculation of the **Analog out Xx scale factor**

To display the drive speed, use an analog instrument with field of measurement from 0 ... 2V. This means that, to display the speed of the drive, a voltage of 2V on the analog output of the drive must correspond to the maximum speed. With a scale factor of 1 this would be 10V (Scale factor = 2V / 10 V = 0.200).

Menu	PAR	Description	UM	Type	FB BIT	Def	Min	Max	Acc	Mod
15.18	1866	Analog out 1X mon	cnt	INT16		0	0	0	ER	VS

The actual value of the voltage present on analog output 1 of the expansion card is displayed.

Menu	PAR	Description	UM	Type	FB BIT	Def	Min	Max	Acc	Mod
15.19	1868	Analog out 2X mon	cnt	INT16		0	0	0	ER	VS

The actual value of the voltage or current present on analog output 2 of the expansion card is displayed.

Menu	PAR	Description	UM	Type	FB BIT	Def	Min	Max	Acc	Mod
15.20	1874	An out 1X absolute		ENUM		Disable	0	1	ERW	VS
15.21	1876	An out 2X absolute		ENUM		Disable	0	1	ERW	VS

Enables the relative analog output as an absolute value. If this parameter is set to 1 the voltage on the analog output assumes the value of 0 - 10V regardless of the sign of the command signal.

- 0 Disable
- 1 Enable

Menu	PAR	Description	UM	Type	FB BIT	Def	Min	Max	Acc	Mod
15.22	1882	Analog out 1X min	cnt	INT16		0	-32768	+32767	ERW	VS
15.23	1884	Analog out 1X max	cnt	INT16		16384	-32768	+32767	ERW	VS

Setting of the minimum and maximum values for the analog output for the voltage present on analog output 1 of the expansion card.

Menu	PAR	Description	UM	Type	FB BIT	Def	Min	Max	Acc	Mod
15.24	1886	Analog out 1X type		ENUM		0..10V	0	3	ERW	VS
15.27	1898	Analog out 2X type		ENUM		0..10V	0	3	ERW	VS

Selection of the programmed signal on analog output 2 of the expansion card. Depending on the output signal, move the S3 switch on the regulation card. The standard output is coded for the signal in voltage.

- 0 0...20mA
- 1 4..20mA
- 2 -10V..+10V
- 3 0..10V

If set to **0** the analog output sends 0...20mA

If set to **1** the analog output sends 4...20mA

If set to **2** the analog output sends -10..+10V

If set to **3** the analog output sends 0...10V

Menu	PAR	Description	UM	Type	FB BIT	Def	Min	Max	Acc	Mod
15.25	1890	Analog out 2X min	cnt	INT16		0	-32768	+32767	ERW	VS
15.26	1892	Analog out 2X max	cnt	INT16		16384	-32768	+32767	ERW	VS

Setting of the minimum and maximum values for the analog output in current or voltage present on analog output 2 of the expansion card.

16 – MOTOR DATA

From this menu you can enter the motor plate data and “basic” values for the voltage/frequency characteristics. It is important to enter the correct data in order to optimize drive operation and that of the application as a whole. These data are required in order to obtain:

- a) Computation of the normalization factors necessary for regulation
- b) Computation of the estimated values for the motor parameters necessary for regulation

Rated voltage, Rated speed, Rated frequency, Rated current, Cos phi, Basic voltage and Basic frequency must be entered (the Cos phi default value can be used if this value is not present on the plate). After entering these parameters, send a Take motor par command to calculate (a) and (b) above. The motor cannot be enabled until the Take motor par command has been set. If some results are inconsistent, or if the motor is much smaller than the inverter, an error message is displayed indicating a numerical capacity overflow and the previous set of parameters is restored in the “Mot plate data” sub-menu.

Motor & Co.			
Type: ABCDE	IEC 34-1 / VDE 0530		
Motor: 3 phase	50 Hz	Nr	12345-91
Rated voltage	400 V	I nom	6.7 A
Rated power	3 kW	Power factor	0.8
Rated speed (n _n)	1420 rpm		
IP54	Iso KI F	S1	
Made in			

Motor & Co.			
Type: ABCDE	IEC 34-1 / VDE 0530		
Motor: 3 phase	60 Hz	Nr	12345-91
Rated voltage	575 V	I nom	2 A
Rated power	2 Hp	Power factor	0.83
Rated speed (n _n)	1750 rpm	Efficiency	86.5
IP54	Iso KI F	S1	
Made in			

kW and HP motor data plates

Menu	PAR	Description	UM	Type	FB BIT	Def	Min	Max	Acc	Mod
16.1	2000	Rated voltage	V	FLOAT		SIZE	50.0	690.0	RWZS	VS

Set the motor rated voltage as indicated on the data plate. This is the voltage the drive must supply at the motor rated frequency.

Menu	PAR	Description	UM	Type	FB BIT	Def	Min	Max	Acc	Mod
16.2	2002	Rated current	A	FLOAT		SIZE	1.0	2200.0	RWZS	VS

The motor rated current at its rated power (kW / Hp) and voltage (indicated on the motor data plate). If using a single drive to control several motors connected in parallel (only possible in the V/f mode), enter a value that corresponds to the sum of the rated currents of all the motors; in this case do not perform any self-tuning operations.

Menu	PAR	Description	UM	Type	FB BIT	Def	Min	Max	Acc	Mod
16.3	2004	Rated speed	rpm	FLOAT		SIZE	10.0	32000.0	RWZS	VS

Rated speed of the motor with full load in rpm. In some motors the synchronous speed (e.g. 1500 rpm for a 4-pole motor) and slippage, i.e. the loss of revolutions between the motor idling condition and the rated load condition (e.g. 80 rpm), is indicated. Enter the following: synchronous speed - slippage.

Menu	PAR	Description	UM	Type	FB BIT	Def	Min	Max	Acc	Mod
16.4	2006	Rated frequency	Hz	FLOAT		SIZE	10.0	1000.0	RWZS	VS

Rated frequency of the motor expressed in Hz, at which the flux weakening range starts.

Menu	PAR	Description	UM	Type	FB BIT	Def	Min	Max	Acc	Mod
16.5	2008	Pole pairs		UINT16		SIZE	1	20	RWZS	VS

Motor pole pairs. The number of motor pole pairs is calculated using the motor plate data and applying the following formula:

$$P = \frac{60 [s] \times f [Hz]}{nN [rpm]}$$

Where:

p = motor pole pairs

f = motor rated frequency (P. 2006)

nN = motor rated speed (P. 2004)

Menu	PAR	Description	UM	Type	FB BIT	Def	Min	Max	Acc	Mod
16.6	2010	Rated power	kW	FLOAT		SIZE	0.1	1500.0	RWZS	VS

Rated power of the motor at the rated voltage and frequency. This value represents the mechanical power produced on the motor shaft.

Menu	PAR	Description	UM	Type	FB BIT	Def	Min	Max	Acc	Mod
16.7	2012	Rated power factor		FLOAT		SIZE	0.6	0.95	RWZS	VS

Motor power factor, as indicated on the data plate (Cos φ). This parameter is not always present on the motor data plate: in that case use the default value present in the drive.

Menu	PAR	Description	UM	Type	FB BIT	Def	Min	Max	Acc	Mod
16.8	2020	Take parameters		BIT		0	0	1	RWZ	VS

Saves the set motor data in the drive. This command must be supplied last after entering the appropriate values of all the parameters listed above. This means calculating the normalization factors (a) and estimated values for the motor parameters (b). The drive cannot be started until the **Take parameters** command has been set.

Note ! This is not saved permanently. Use the “**Save Parameters**” command in the **DRIVE CONFIG** menu to save in the permanent memory.

Menu	PAR	Description	UM	Type	FB BIT	Def	Min	Max	Acc	Mod
16.9	2022	Autotune rotation		BIT		0	0	1	RWZ	VS

Performs self-tuning in rotation: the motor must be uncoupled from the load or the transmission must not represent more than 5% of the load. This procedure allows the greatest degree of accuracy in measuring the motor parameters. To execute the command you must first open the hardware enabling contact between terminals 7 and S3. Next set the **Regulation mode** parameter to **Autotune**. If you are not already in Local mode, press the Local key (the **LOC** LED will light up) and close the hardware enabling contact again (terminals 7 and S3). Self-tuning can now be performed. At the end of the self-tuning procedure, open the contact between terminals 7 and S3 again and reset the parameters that were modified.

Menu	PAR	Description	UM	Type	FB BIT	Def	Min	Max	Acc	Mod
16.10	2024	Autotune still		BIT		0	0	1	RWZ	VS

Performs self-tuning with the motor coupled to the transmission. The self-tuning procedure may cause limited rotation of the motor shaft. To perform self-tuning, follow the procedure described for the previous parameter.

Menu	PAR	Description	UM	Type	FB BIT	Def	Min	Max	Acc	Mod
16.11	2026	Autotune mode		ENUM		Reduced	0	1	ERWZ	VS
<p>Selection of the motor parameter self-tuning mode.</p> <p>0 Reduced 1 Extended</p> <p>If set to 0 all the motor parameters are measured except those relating to the non-linear saturation curve. Use this mode to obtain a faster self-tuning procedure.</p> <p>If set to 1 all the motor parameters are measured. Use this mode to obtain maximum efficiency: this procedure may take a few minutes.</p>										

Menu	PAR	Description	UM	Type	FB BIT	Def	Min	Max	Acc	Mod
16.12	2028	Take par status		ENUM		Required	0	0	R	VS
<p>Indication of the status of parameter saving.</p> <p>0 Required 1 Done</p> <p>The parameter displays the Required message when the motor parameters that have been entered need to be saved. When they have been saved the parameter indicates Done.</p>										

Menu	PAR	Description	UM	Type	FB BIT	Def	Min	Max	Acc	Mod
16.13	2030	Autotune status		ENUM		Required	0	0	R	VS
<p>Indication of the status of execution of motor parameter self-tuning.</p> <p>0 Required 1 Done</p> <p>The parameter displays the Required message when motor parameter self-tuning is required. When self-tuning is complete the parameter indicates Done.</p>										

Menu	PAR	Description	UM	Type	FB BIT	Def	Min	Max	Acc	Mod
16.14	2050	Measured Rs	ohm	FLOAT		CALCF	0.0005	200.0	ERWS	VS
<p>Measured stator resistance value.</p>										

Menu	PAR	Description	UM	Type	FB BIT	Def	Min	Max	Acc	Mod
16.15	2052	Measured DTL	V	FLOAT		0.0	0.0	100.0	ERWS	VS
<p>Measured value of dead time compensation.</p>										

Menu	PAR	Description	UM	Type	FB BIT	Def	Min	Max	Acc	Mod
16.16	2054	Measured DTS	V/A	FLOAT		0.0	0.0	100.0	ERWS	VS
<p>Measured compensation gradient value.</p>										

Menu	PAR	Description	UM	Type	FB BIT	Def	Min	Max	Acc	Mod
16.17	2056	Measured Lsig	mH	FLOAT		CALCF	0.1	200.0	ERWS	VS
<p>Measured leakage inductance value.</p>										

Menu	PAR	Description	UM	Type	FB BIT	Def	Min	Max	Acc	Mod
16.18	2058	Measured ImN	A	FLOAT		CALCF	0.1	1500.0	ERWS	VS
<p>Measured rated magnetizing current value.</p>										

Menu	PAR	Description	UM	Type	FB BIT	Def	Min	Max	Acc	Mod
16.19	2060	Measured ImX	A	FLOAT		CALCF	0.0	0.0	ERWS	VS
<p>Measured magnetizing current saturation value.</p>										

Menu	PAR	Description	UM	Type	FB BIT	Def	Min	Max	Acc	Mod
16.20	2062	Measured FlxN	Wb	FLOAT		CALCF	0.05	10.0	ERWS	VS
Measured rated flux value.										
16.21	2064	Measured FlxX	Wb	FLOAT		CALCF	0.0	0.0	ERWS	VS
Measured flux saturation value.										
16.22	2066	Measured P1		FLOAT		0.05	0.0	1.0	ERWS	VS
Measured value of the first parameter to define the motor magnetization curve.										
16.23	2068	Measured P2		FLOAT		9.0	3.0	18.0	ERWS	VS
Measured value of the second parameter to define the motor magnetization curve.										
16.24	2070	Measured P3		FLOAT		0.87	0.0	1.0	ERWS	VS
Measured value of the third parameter to define the motor magnetization curve.										
16.25	2072	Measured Rr	ohm	FLOAT		CALCF	0.0005	200.0	ERWS	VS
Measured rotor resistance value.										
16.26	2078	Take tune parameters		BIT		0	0	1	ERWZ	VS
Saves the motor data calculated by the self-tuning procedure in the drive.										

Note ! Data are not saved permanently. Use the “**Save Parameters**” command in the **DRIVE CONFIG** menu to save in the permanent memory.

18 – SPEED REG GAINS

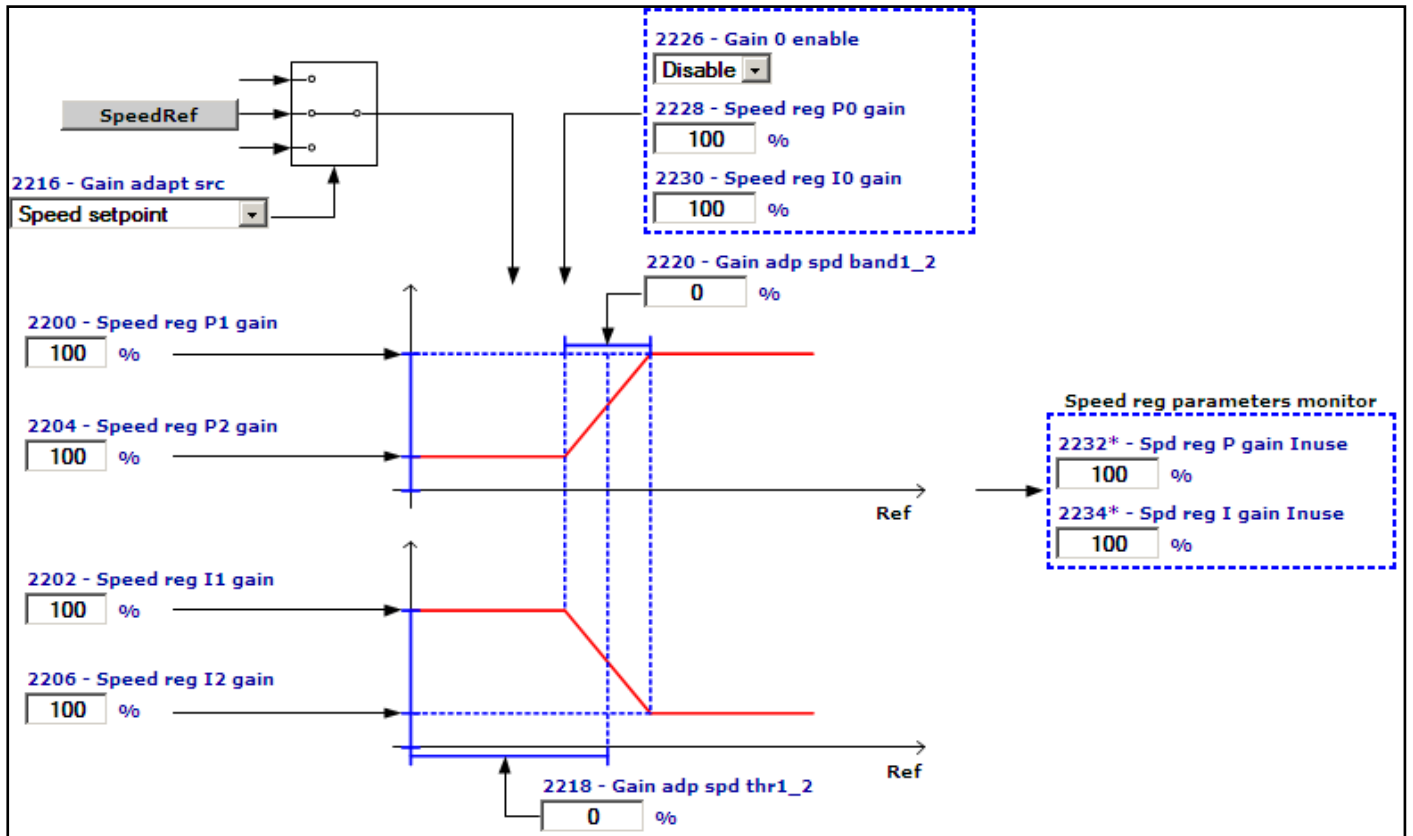

The speed adaptive allows different speed regulator gains to be obtained according to the speed or another value. The behaviour of the speed regulator can thus be configured in the best way for the specific application requirements.

Note ! Current, flux and voltage regulators can be set using the self-tuning procedure. If this is not successful, current and flux regulators can be tuned manually (this does not apply to voltage regulators, which must not be modified by the user). The speed regulator must be tuned manually. Gains are usually adjusted according to the drive speed.

Menu	PAR	Description	UM	Type	FB BIT	Def	Min	Max	Acc	Mod
18.1	2200	Speed reg P1 gain	perc	INT16		100	0	1000	RW	_S
18.2	2202	Speed reg I1 time	perc	INT16		100	0	1000	RW	_S

Setting of the proportional and integral gain of the speed regulator, set 1.

Menu	PAR	Description	UM	Type	FB BIT	Def	Min	Max	Acc	Mod
18.3	2204	Speed reg P2 gain	perc	INT16		100	0	1000	ERW	_S
18.4	2206	Speed reg I2 time	perc	INT16		100	0	1000	ERW	_S

Setting of the proportional and integral gain of the speed regulator, set 2.

Menu	PAR	Description	UM	Type	FB BIT	Def	Min	Max	Acc	Mod
18.5	2216	Gain adapt src		LINK	16/32	664	0	16384	ERW	_S

Selection of the origin (source) of the signal to be used for the adaptive speed gain. The values that can be associated with the function are listed in the “L_REF” selection list.

Menu	PAR	Description	UM	Type	FB BIT	Def	Min	Max	Acc	Mod
18.6	2218	Gain adapt spd thr 1_2	perc	FLOAT		0.0	0.0	100.0	ERW	_S

Setting of the speed threshold for changing gains from set 1 to set 2.

Menu	PAR	Description	UM	Type	FB BIT	Def	Min	Max	Acc	Mod
18.7	2220	Gain adapt spd band 1_2	perc	FLOAT		0.0	0.0	100.0	ERW	_S

Setting of the band within which gains vary between set 1 and set 2. The use of this parameter ensures a smooth transition between the two parameter sets.

Menu	PAR	Description	UM	Type	FB BIT	Def	Min	Max	Acc	Mod
18.8	2226	Gain 0 enable		ENUM		Disable	0	1	ERW	_S

Enabling of the gain at zero speed.

- 0 Disable
- 1 Enable

When this parameter is set to 0 the control of gains at zero speed is disabled.

When this parameter is set to 1 the control of gains at zero speed is enabled. This function is used to improve the response of the motor below the zero speed threshold (Speed zero threshold)..

Menu	PAR	Description	UM	Type	FB BIT	Def	Min	Max	Acc	Mod
18.9	2228	Speed reg P0 gain	perc	INT16		100	0	1000	ERW	_S

Setting of the proportional gain of the speed regulator at zero speed.

Menu	PAR	Description	UM	Type	FB BIT	Def	Min	Max	Acc	Mod
18.10	2230	Speed reg I0 gain	perc	INT16		100	0	1000	ERW	_S

Setting of the integral gain of the speed regulator at zero speed.

Menu	PAR	Description	UM	Type	FB BIT	Def	Min	Max	Acc	Mod
18.11	2232	Spd reg P gain Inuse	perc	INT16	16/32	100	0	1000	ER	_S

The current proportional coefficient of the speed regulator is displayed as a percentage.

Menu	PAR	Description	UM	Type	FB BIT	Def	Min	Max	Acc	Mod
18.12	2234	Spd reg I gain Inuse	perc	INT16	16/32	100	0	1000	ER	_S

The current integral coefficient of the speed regulator is displayed as a percentage.

Menu	PAR	Description	UM	Type	FB BIT	Def	Min	Max	Acc	Mod
18.13	2236	Speed reg P gain	N/rpm	FLOAT		CALCF	0.0	500.0	ERWS	_S

Setting of the proportional coefficient of the speed regulator.

Menu	PAR	Description	UM	Type	FB BIT	Def	Min	Max	Acc	Mod
18.14	2238	Speed reg I time	ms	FLOAT		CALCF	1.0	5000.0	ERWS	_S

Setting of the integral coefficient of the speed regulator.

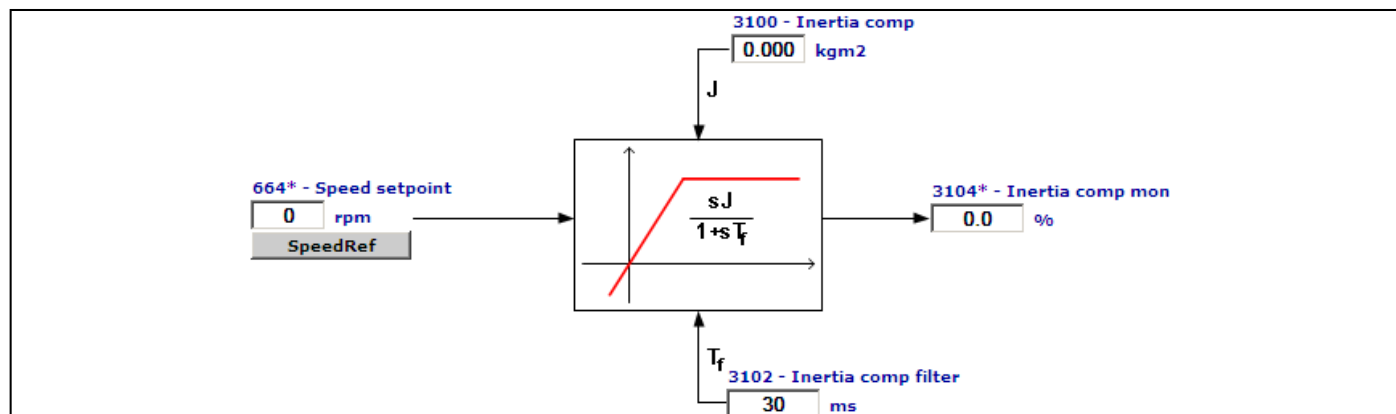

Menu	PAR	Description	UM	Type	FB BIT	Def	Min	Max	Acc	Mod
18.15	2240	Inertia	kgm ²	FLOAT		SIZE	0.001	100.0	RWZS	_S

Setting of the inertia compensation coefficient. An increase in the dynamic response of the speed regulator to a variation in the reference, can be modified by changing the current value during the acceleration/deceleration phase, to counter the applied machine inertia.

Menu	PAR	Description	UM	Type	FB BIT	Def	Min	Max	Acc	Mod
18.16	2242	Bandwidth	rad/s	FLOAT		SIZE	1.0	500.0	RWZS	_S

Setting of the bandwidth. Increasing the setting of this parameter increases the dynamic response and makes the system more rigid.

19 – REGULATOR PARAM

Menu	PAR	Description	UM	Type	FB BIT	Def	Min	Max	Acc	Mod
19.1	2250	Current reg P gain	V/A	FLOAT		CALCF	0.0	0.0	ERWS	_S

Setting of the proportional coefficient of the current regulator.

Menu	PAR	Description	UM	Type	FB BIT	Def	Min	Max	Acc	Mod
19.2	2252	Current reg I time	ms	FLOAT		CALCF	0.01	10000.0	ERWS	_S

Setting of the integral coefficient of the current regulator.

Menu	PAR	Description	UM	Type	FB BIT	Def	Min	Max	Acc	Mod
19.3	2260	Flux reg P gain	A/Wb	FLOAT		CALCF	0.0	0.0	ERWS	_S

Setting of the proportional coefficient of the flux regulator.

Menu	PAR	Description	UM	Type	FB BIT	Def	Min	Max	Acc	Mod
19.4	2262	Flux reg I time	ms	FLOAT		CALCF	0.1	10000.0	ERWS	_S

Setting of the integral coefficient of the flux regulator.

Menu	PAR	Description	UM	Type	FB BIT	Def	Min	Max	Acc	Mod
19.5	2264	Flux reg P gain OL	A/Wb	FLOAT		CALCF	0.0	0.0	ERWS	_S

Setting of the flux regulator proportional gain when the drive is used in open loop Flux vector OL control mode. This parameter is set automatically by the self-tuning procedure.

Menu	PAR	Description	UM	Type	FB BIT	Def	Min	Max	Acc	Mod
19.6	2266	Flux reg I time OL	ms	FLOAT		CALCF	0.1	30000.0	ERWS	_S

Setting of the flux regulator integral time when the drive is used in open loop Flux vector OL control mode. This parameter is set automatically by the self-tuning procedure.

Menu	PAR	Description	UM	Type	FB BIT	Def	Min	Max	Acc	Mod
19.7	2270	Voltage reg P gain	Wb/V	FLOAT		CALCF	0.0	0.0	ERWS	_S

Setting of the proportional coefficient of the voltage regulator.

Menu	PAR	Description	UM	Type	FB BIT	Def	Min	Max	Acc	Mod
19.8	2272	Voltage reg I time	s	FLOAT		CALCF	0.1	100.0	ERWS	S_

Setting of the integral coefficient of the voltage regulator.

Dead time compensation

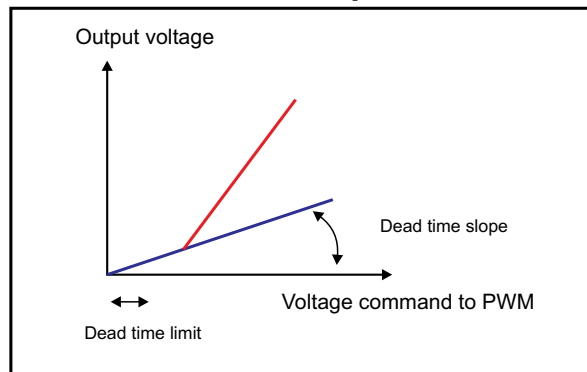

The dead time compensation function (**Dead time compensation**), compensates the distortion of output voltage caused by the voltage drop on the IGBT devices and their switching characteristics.

Distortion of output voltage could cause irregular motor rotation.

Menu	PAR	Description	UM	Type	FB BIT	Def	Min	Max	Acc	Mod
19.9	2280	Dead time limit	V	FLOAT		SIZE	0.0	50.0	ERWS	VS
Setting of the dead time voltage compensation value.										
19.10	2282	Dead time slope	V/A	FLOAT		SIZE	0.0	200.0	ERWS	VS
Setting of the dead time compensation slope value.										
19.11	2290	Voltage base	V	FLOAT		CALCF	50.0	690.0	ERWS	_S
Setting of the voltage value that determines the threshold at which flux weakening starts (maximum drive output voltage). If this parameter is set to a value equal to the nominal speed of the motor, operation is at nominal flux in the constant torque region and weakened flux at higher frequencies. The default value is set to the voltage supply value.										
19.12	2292	Voltage margin	perc	FLOAT		5.0	0.0	10.0	ERWS	_S
Setting of the voltage regulation margin according to the available voltage. In case of a Voltage base setting close to or equal to the actual mains value, Voltage margin represents the margin allowable by the voltage regulation to perform rapid current variations when load steps are suddenly applied. A value of 5% allows a very fast response to load steps but with a loss of output voltage and thus power output (reduced power output). The minimum value (1%) allows a maximum output voltage (around 98%) of the mains voltage to be achieved but with loss of quality of the dynamic response.										
19.13	2300	Minimum speed OL	rpm	INT16		30	0	CALCI	ERW	_S
Setting of the minimum speed threshold in the Flux vector OL control mode. Below this limit the sensorless regulator is disabled.										
19.14	2302	Min speed delay OL	ms	UINT16		200	0	5000	ERW	_S
Setting of the delay for disabling the sensorless regulator.										
19.15	2304	Speed filter OL	ms	FLOAT		5.0	0.1	20.0	ERWZ	_S
Setting of the time constant for the estimated speed in Flux vector OL mode. By increasing this parameter it is possible to reduce the level of disturbance of the estimated speed, but the speed control dynamics are also lowered.										
19.16	2306	Flux observe gain OL		FLOAT		250.0	10.0	5000.0	ERW	_S
Proportional gain of the internal flux observer in the open-loop flux vector control mode. In case of instability, try changing the value and setting half or twice the default value.										
19.17	2308	OverFlux perc	perc	FLOAT		100.0	100.0	140.0	ERW	_S
The value is expressed as the percentage in excess of the rated flux.										

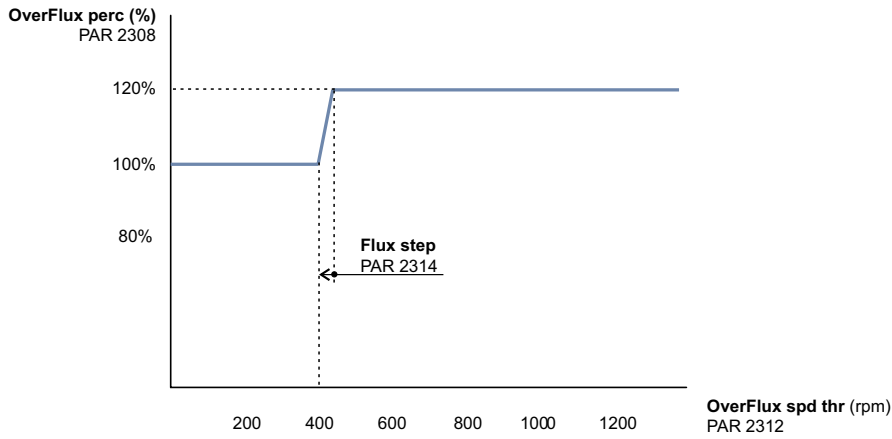

Menu	PAR	Description	UM	Type	FB BIT	Def	Min	Max	Acc	Mod
19.18	2310	Flux weakening OL		ENUM		Enable	0	1	ERWZ	__S

Enables or disables flux reduction in the open-loop flux vector control mode.

If set to Disable, the flux is not reduced when the speed of the motor exceeds the nominal speed. This results in loss of control and instability.

To prevent this problem, set the parameter to Enable.

In the open-loop mode a flux value of less than the nominal speed of the motor is advantageous in terms of stability.

0 Disable

1 Enable

Menu	PAR	Description	UM	Type	FB BIT	Def	Min	Max	Acc	Mod
19.19	2312	OverFlux spd thr	rpm	FLOAT		400.0	10.0	1000.0	ERW	__S

Speed limit below which the overflux value set in PAR 2308 **OverFlux perc.**

Menu	PAR	Description	UM	Type	FB BIT	Def	Min	Max	Acc	Mod
19.20	2314	Flux step		FLOAT		20.0	1	2000	ERW	__S

Setting of the ramp time in the transition between the rated flux and the overflux value set in PAR 2308 **OverFlux perc.**

Menu	PAR	Description	UM	Type	FB BIT	Def	Min	Max	Acc	Mod
19.21	2320	Magnetization time	ms	UINT16		256	128	4096	ERWZ	__S

This parameter is used to slow down the magnetisation transient and prevent the motor shaft from rotating due to the alignment of the stator and rotor.

21 – V/F PARAMETERS

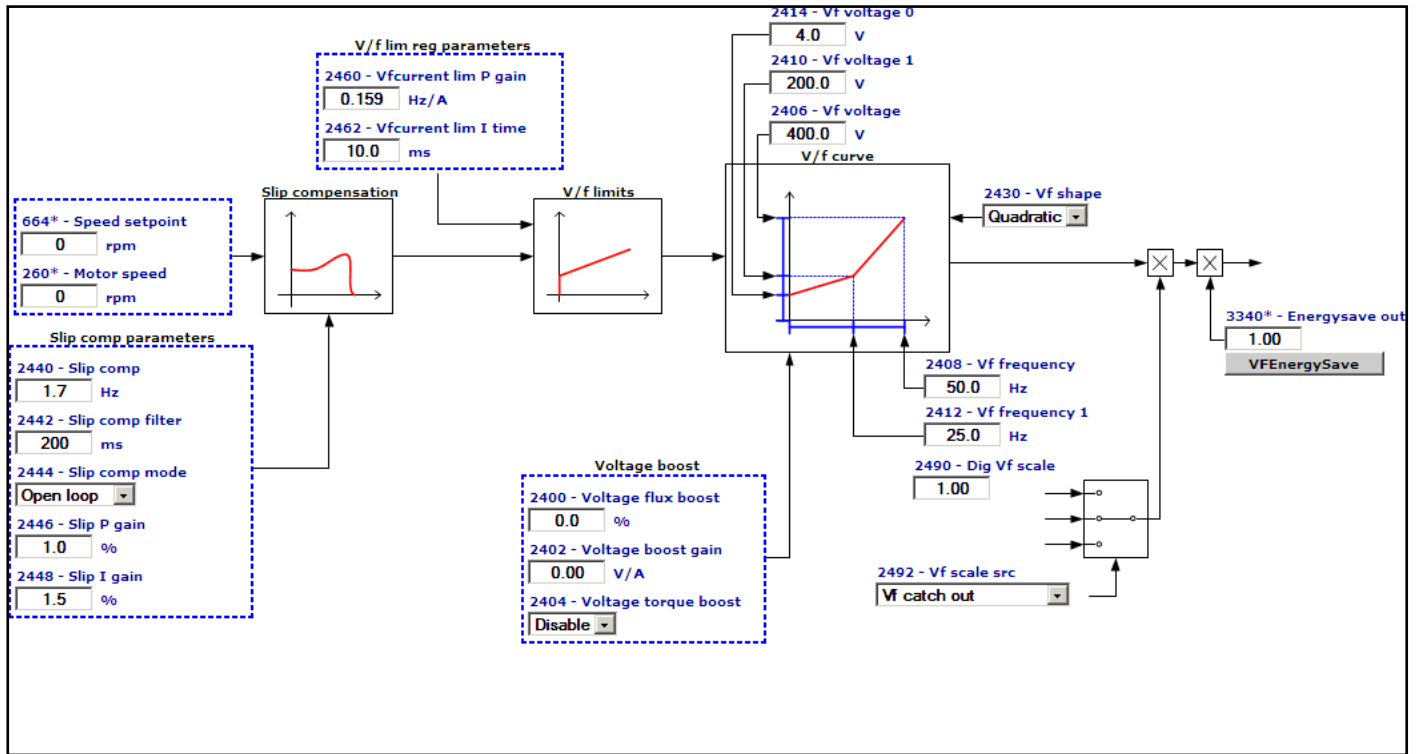

Menu	PAR	Description	UM	Type	FB BIT	Def	Min	Max	Acc	Mod
21.1	2400	Voltage flux boost	perc	FLOAT		0.0	0.0	15.0	RWS	V

Setting of the boost voltage. The resistive impedance of the stator windings causes a voltage drop within the motor, which results in a reduction in torque in the lower speed range. This effect can be compensated by boosting the output voltage. If self-tuning is performed, the boost value is calculated automatically.

Menu	PAR	Description	UM	Type	FB BIT	Def	Min	Max	Acc	Mod
21.2	2402	Voltage boost gain	V/A	FLOAT		0.0	0.0	0.0	ERWS	V

Manual setting of the voltage boost gain to apply to the motor terminals for the set V/f characteristic curve. If self-tuning is performed, the boost value is calculated automatically.

Menu	PAR	Description	UM	Type	FB BIT	Def	Min	Max	Acc	Mod
21.3	2404	Voltage torque boost		ENUM		Disable	0	1	ERWZ	V

Enables vector torque compensation. The default drive setting is to pure V/f control.

- 0 Disable
- 1 Enable

Menu	PAR	Description	UM	Type	FB BIT	Def	Min	Max	Acc	Mod
21.4	2406	Vf voltage	V	FLOAT		CALCF	10.0	690.0	ERWZS	V

Setting of the maximum voltage value to be applied at the motor terminals (usually set according to the motor data plate).

Menu	PAR	Description	UM	Type	FB BIT	Def	Min	Max	Acc	Mod
21.5	2408	Vf frequency	Hz	FLOAT		CALCF	10.0	2000.0	ERWZS	V

Setting of the motor rated frequency (indicated on the motor data plate)

This is the frequency at which the drive output voltage reaches the maximum output voltage (**Vf voltage**) on the motor.

Menu	PAR	Description	UM	Type	FB BIT	Def	Min	Max	Acc	Mod
21.6	2410	Vf voltage 1	V	FLOAT		CALCF	CALCF	CALCF	ERWZS	V

Setting of an intermediate voltage value for the custom V/f characteristic curve.

Menu	PAR	Description	UM	Type	FB BIT	Def	Min	Max	Acc	Mod
21.7	2412	Vf frequency 1	Hz	FLOAT		CALCF	0.0	CALCF	ERWZS	V

Setting of an intermediate frequency value for the custom V/f characteristic curve.

Menu	PAR	Description	UM	Type	FB BIT	Def	Min	Max	Acc	Mod
21.8	2414	Vf voltage 0	V	FLOAT		CALCF	0.0	CALCF	ERWZS	V

Compensation of IR voltage drop at 0 Hz. This parameter must be increased in case of pure V/f control. The increase depends on the size of the motor. Values that are too high could cause an overcurrent and motor saturation.

Menu	PAR	Description	UM	Type	FB BIT	Def	Min	Max	Acc	Mod
21.9	2430	Vf shape		ENUM		2 Quadratic	0	2	ERWS	V

Selection of the type of V/f characteristic curve

- 0 Linear
- 1 Custom
- 2 Quadratic

Set **0 (Linear)** to obtain a linear V/f characteristic curve, on which the intermediate points are reset to a value that is equal to half those of parameters **2406** and **2408**.

The Boost joins the curve automatically.

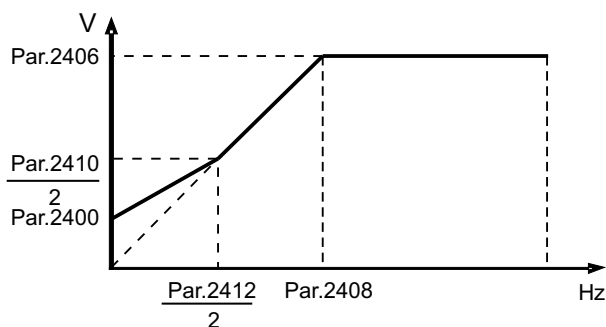

Set **1 (Custom)** to obtain a customized V/f characteristic curve, in which the intermediate voltage and frequency values are defined by parameters **2410** and **2412**, as is the point at which the Boost joins the characteristic curve.

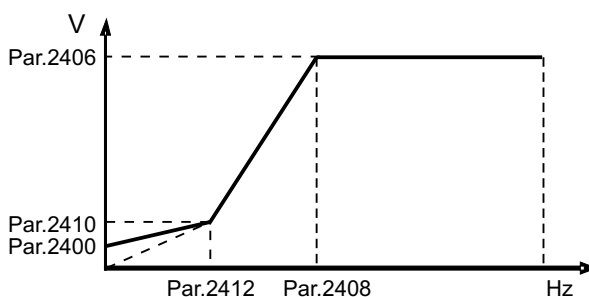

Set **2 (Quadratic)** to obtain a quadratic V/f characteristic curve, useful for controlling pumps and fans, where torque is proportional to the square of the speed. When this type of curve is selected, the median voltage point is fixed at 0.25% of the maximum output voltage (par.**2406**), and the median frequency point at 50% of the basic frequency (par.**2408**).

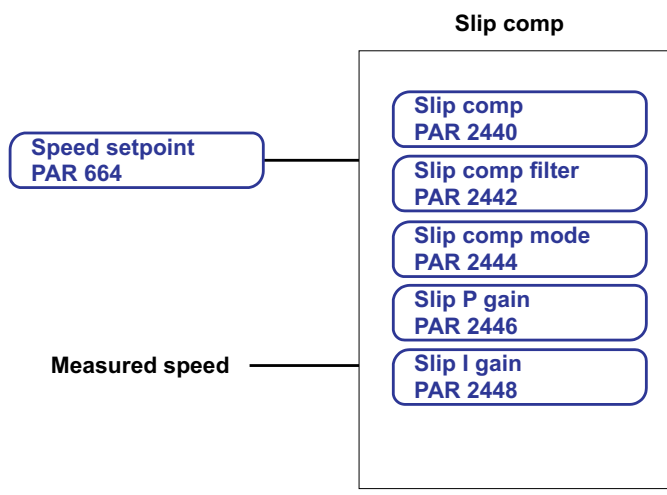
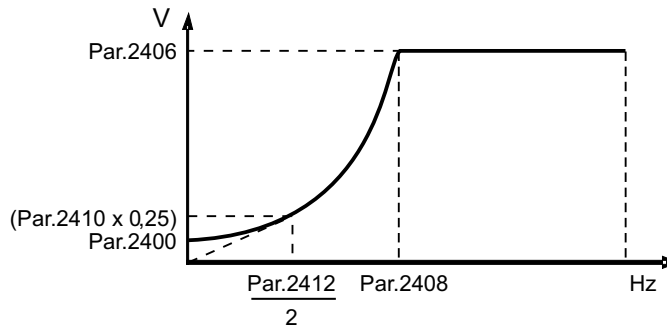

Menu	PAR	Description	UM	Type	FB BIT	Def	Min	Max	Acc	Mod
21.10	2440	Slip comp	Hz	FLOAT		CALCF	0.0	10.0	RWS	V

Setting of the slip compensation. When the asynchronous motor is loaded, the mechanical speed of the motor shaft varies according to the electric slippage, which affects torque generation. The slip compensation function can be used to maintain a constant motor shaft speed. Compensation is performed by varying the drive output frequency as a function of its output current and the motor parameters. Thus, to obtain the best effect, the motor plate data must be set appropriately, and the correct stator resistance value (Par.2050) must be set or measured using the self-tuning function, The slip compensation value is calculated automatically during the self-tuning procedure or set manually in this parameter.

During slip compensation tuning the drive must not be in the current limit condition.

Menu	PAR	Description	UM	Type	FB BIT	Def	Min	Max	Acc	Mod
21.11	2442	Slip comp filter	ms	UINT16		200	50	5000	ERW	V

Setting of the slip compensation filter. The value set in this parameter determines the slip compensation function reaction time. The lower this parameter is set, the greater the slip compensation reaction. If this parameter is too low, it could cause undesirable oscillations in speed after sudden variations to the applied load.

Menu	PAR	Description	UM	Type	FB BIT	Def	Min	Max	Acc	Mod
21.12	2444	Slip comp mode		ENUM		Open loop	0	1	ERW	V

Setting of the slip compensation mode.

0 Open loop

When set to **0 (Open loop)** the slip compensation value is that set manually in parameter 5210 or calculated by the self-tuning procedure.

Menu	PAR	Description	UM	Type	FB BIT	Def	Min	Max	Acc	Mod
21.13	2446	Slip P gain	perc	FLOAT		1.0	0.0	100.0	ERWS	V

Setting of the slip compensation proportional gain.

Menu	PAR	Description	UM	Type	FB BIT	Def	Min	Max	Acc	Mod
21.14	2448	Slip I gain	perc	FLOAT		1.5	0.0	100.0	ERWS	V

Setting of the slip compensation integral gain.

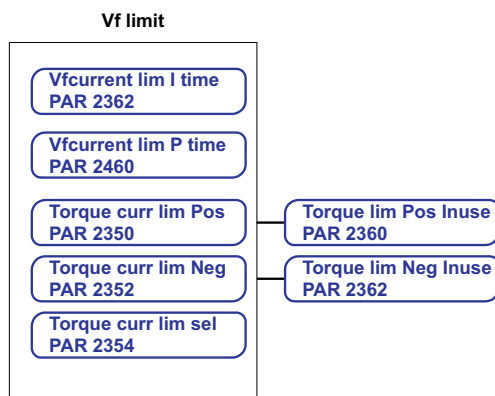

Menu	PAR	Description	UM	Type	FB BIT	Def	Min	Max	Acc	Mod
21.15	2460	Vfcurrent lim P gain	Hz/A	FLOAT		CALCF	0.0	1000.0	ERWS	V

Setting of the proportional gain limit in V/f mode. This is calculated automatically if the self-tuning procedure is performed.

Menu	PAR	Description	UM	Type	FB BIT	Def	Min	Max	Acc	Mod
21.16	2462	Vfcurrent lim I time	ms	FLOAT		CALCF	1.0	50.0	ERWS	V

Setting of the proportional gain limit in V/f mode. This is calculated automatically if the self-tuning procedure is performed.

Menu	PAR	Description	UM	Type	FB BIT	Def	Min	Max	Acc	Mod
21.17	2470	Damping gain	perc	UINT16		0	0	100	ERW	V

Setting of the damping gain. The parameter is used to eliminate any oscillations or faults in the drive output current, deriving from configurations capable of generating oscillations in the drive/cable/motor system. If oscillations occur, gradually increase the value of this parameter, until they disappear.

Menu	PAR	Description	UM	Type	FB BIT	Def	Min	Max	Acc	Mod
21.18	2472	Damping threshold 1	Hz	INT16		20	5	100	ERW	V

Setting of the first damping gain regulation threshold. These settings are usually effective for intermediate frequencies and make it possible to limit motor oscillations.

Menu	PAR	Description	UM	Type	FB BIT	Def	Min	Max	Acc	Mod
21.19	2474	Damping threshold 2	Hz	INT16		30	5	100	ERW	V

Setting of the second damping gain regulation threshold. These settings are usually effective for intermediate frequencies and make it possible to limit motor oscillations.

Menu	PAR	Description	UM	Type	FB BIT	Def	Min	Max	Acc	Mod
21.20	2480	Vf min frequency	Hz	FLOAT		1.0	0.2	5.0	ERW	V

Setting of the minimum frequency in the V/f control mode. This represents the minimum output frequency, below which frequency regulations are ineffective. It is not possible to go below this value, regardless of the reference that has been set.

Menu	PAR	Description	UM	Type	FB BIT	Def	Min	Max	Acc	Mod
21.21	2482	Vf min freq delay	ms	UINT16		800	0	5000	ERW	V

Setting of the delay for the minimum frequency signal in the V/f control mode.

Menu	PAR	Description	UM	Type	FB BIT	Def	Min	Max	Acc	Mod
21.22	2490	Dig Vf scale		FLOAT	16/32	1.0	0.0	1.0	ERWZ	V

Setting of a digital multiplier factor for the drive output voltage in the V/f mode.

Menu	PAR	Description	UM	Type	FB BIT	Def	Min	Max	Acc	Mod
21.23	2492	Vf scale src		LINK	16/32	3374	0	16384	ERW	V

Selection of the origin (source) of the signal to be used to set a multiplier factor for the drive output voltage. The associate functions are listed in the "**L_REF**" selection list.

22 – FUNCTIONS

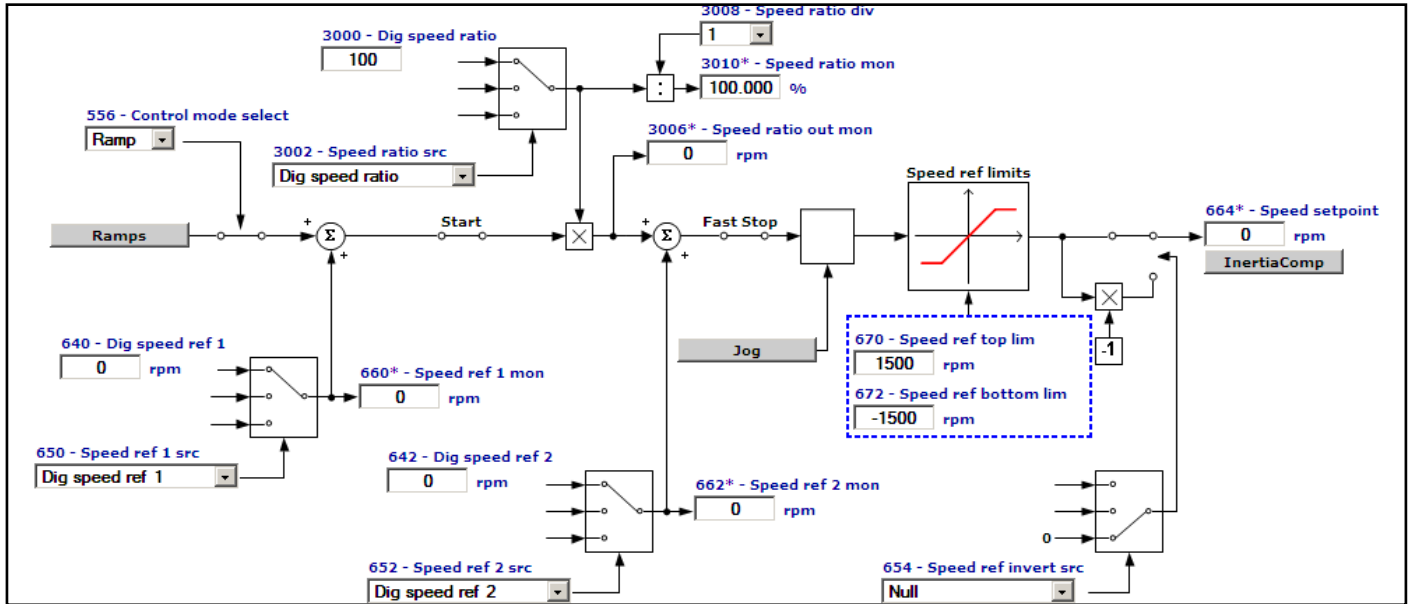

22.1 – FUNCTIONS/SPEED RATIO

Menu	PAR	Description	UM	Type	FB BIT	Def	Min	Max	Acc	Mod
22.1.1	3000	Dig speed ratio	perc	INT16	16/32	100	CALCI	CALCI	ERW	VS

This function allows a configurable speed ratio (Speed ratio) to be applied to the main reference and determines the speed ratio percentage. This setting can be performed in digital form, via fieldbus, or through an analog input. This function is useful in “multi drive” systems where a slip value is required between the various motors being used. The resulting speed value can be read through the Speed ratio mon parameter on a programmable analog output.

Menu	PAR	Description	UM	Type	FB BIT	Def	Min	Max	Acc	Mod
22.1.2	3002	Speed ratio src		LINK	16/32	3000	0	16384	ERW	VS

Selection of the origin (source) of the signal that determines the speed ratio percentage value. The terminal to be associated with this function can be selected from the “L_VREF” selection list.

Menu	PAR	Description	UM	Type	FB BIT	Def	Min	Max	Acc	Mod
22.1.3	3008	Speed ratio div		ENUM		1	1	1000	ERW	VS

This parameter defines the number of decimal positions for setting PAR 3000 **Dig speed ratio**. Possible values are shown in the table below:

Speed ratio divider	Values that can be set in PAR 3000 Dig speed ratio	Corresponding % value
1	0-200	0-200
10	0-2000	0-200.0
100	0-20000	0-200.00
1000	0-32000	0-32.000

1 1
 10 10
 100 100
 1000 1000

Menu	PAR	Description	UM	Type	FB BIT	Def	Min	Max	Acc	Mod
22.1.4	3010	Speed ratio mon	FLOAT	INT16		0	0	0	ER	VS

The speed ratio value to apply to the selected speed reference signal value is displayed.

22.2 – FUNCTIONS/INERTIA COMP

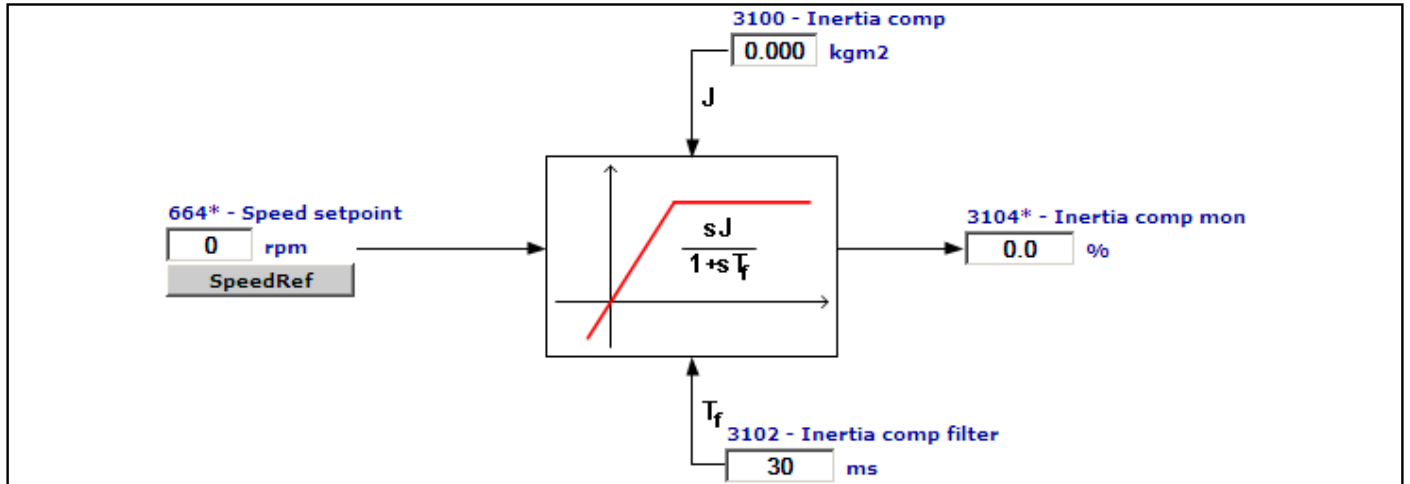

An increase in the dynamic response of the speed regulator with a variation in the reference, can be modified by varying the current value during the acceleration/ deceleration phase, to counter the applied inertia of the machine.

These parameters are calculated by the speed loop self-tuning procedure but can also be set manually by the user.

Menu	PAR	Description	UM	Type	FB BIT	Def	Min	Max	Acc	Mod
22.2.1	3100	Inertia comp	kgm ²	FLOAT		0.0	0.0	100.0	ERWS	_S
Total value of the inertia on the motor shaft in Kgm ² identified during the self-tuning procedure. If known, this value can also be set manually by the user.										

Menu	PAR	Description	UM	Type	FB BIT	Def	Min	Max	Acc	Mod
22.2.2	3102	Inertia comp filter	ms	UINT16		30	1	100	ERW	_S
Setting of a filter on the torque compensation. The filter reduces noise due to speed differentiation in the inertia block.										

Menu	PAR	Description	UM	Type	FB BIT	Def	Min	Max	Acc	Mod
22.2.3	3104	Inertia comp mon	perc	FLOAT	16/32	0.0	0.0	0.0	ER	_S
The value of inertia compensation on the function block output is displayed.										

22.3 – FUNCTIONS/DC BRAKING

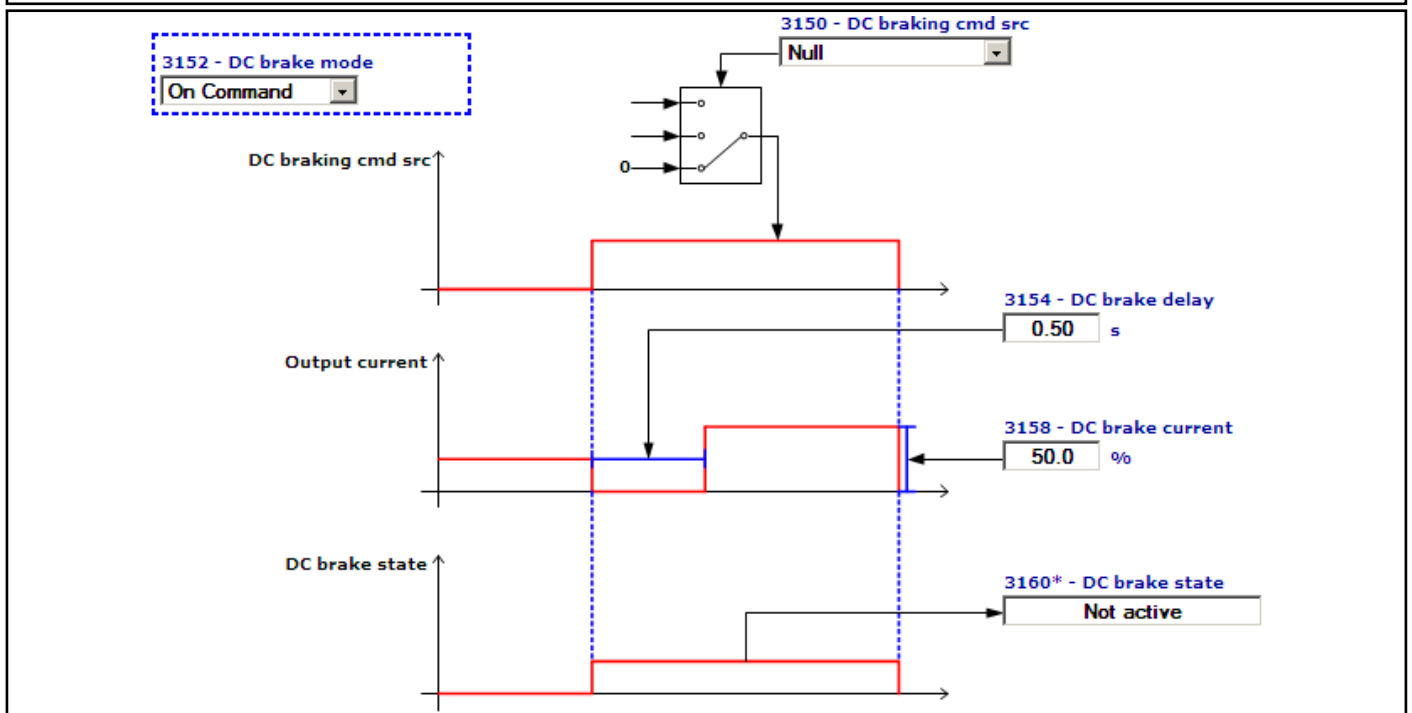
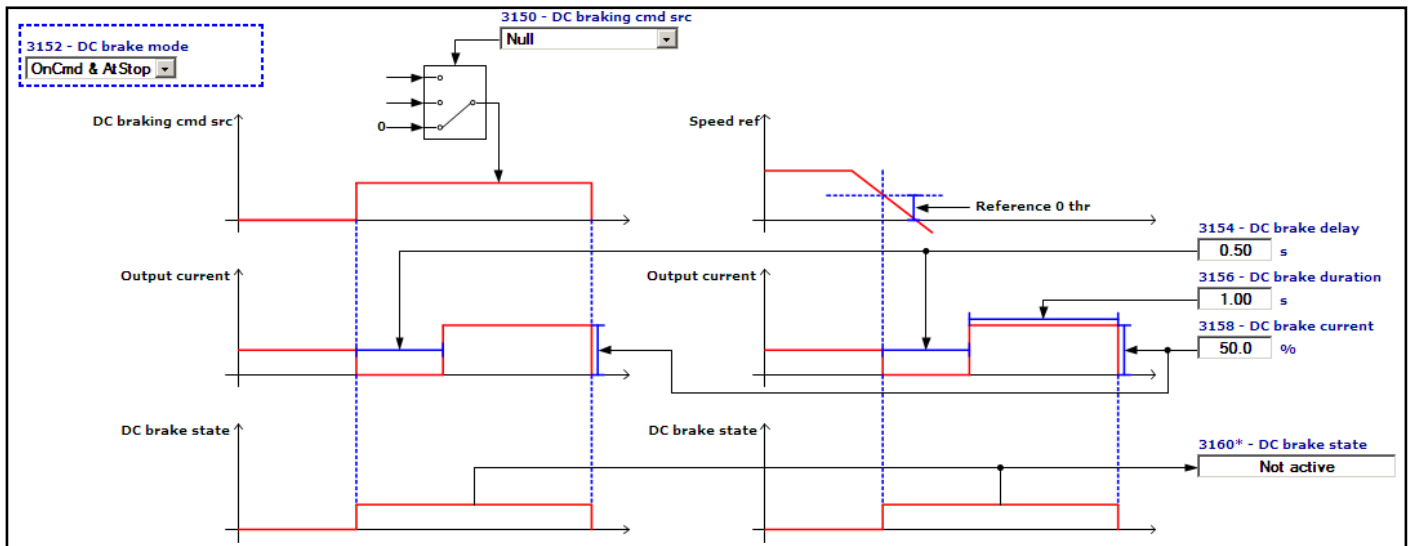
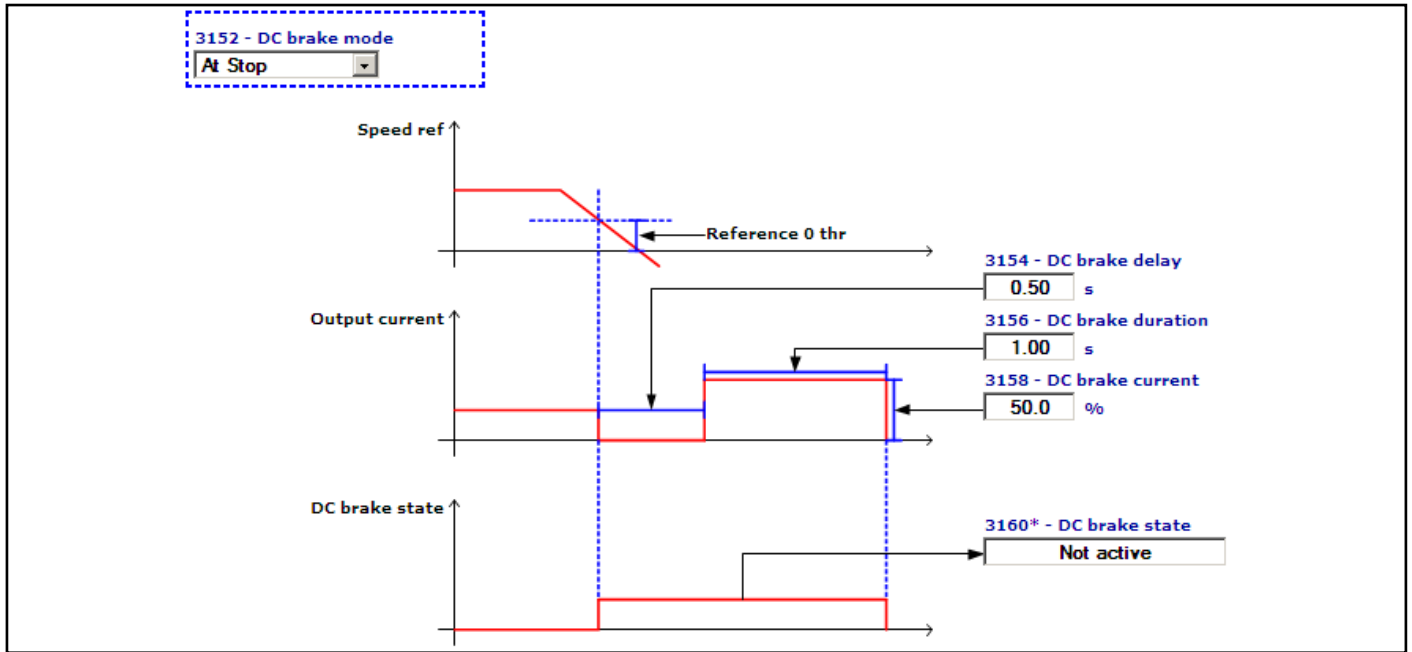

The drive is capable of managing a direct current injection phase. During this phase a braking torque is generated that can be used to stop the motor or block the rotor.

The following characteristics can be configured:

- signal used to activate the direct current injection phase
- direct current injection phase activation mode
- delay between activation of request for DC braking and start of direct current injection
- duration of direct current injection phase
- intensity of injected direct current

This function is useful for:

- slowing the motor running at any speed to zero speed
- slowing a motor driven by the load before applying the start command
- keeping the rotor blocked at the end of a deceleration ramp following a stop command.

This function cannot be used for intermediate braking as the motor speed must be brought to zero.

During the direct current injection phase the kinetic energy of the motor is dissipated as heat in the motor.

The following parameters allow complete control of the function.

Menu	PAR	Description	UM	Type	FB BIT	Def	Min	Max	Acc	Mod
22.3.1	3150	DC braking cmd src		LINK	16	6000	0	16384	ERW	VS

This parameter is used to select the origin (source) of the **DC braking cmd** signal. The signal to be associated with this function can be selected from the "L_DIGSEL2" selection list.

If the command is activated (=1) DC braking is enabled.

In the default condition the origin of the **DC braking cmd** signal is 6000 (disabled).

Menu	PAR	Description	UM	Type	FB BIT	Def	Min	Max	Acc	Mod
22.3.2	3152	DC brake mode		ENUM		Off	0	1	ERW	VS

Setting of the direct current braking mode.

- 0** Off
- 1** At Stop
- 2** On Command
- 3** OnCmd & AtStop

If set to **0** the direct current injection phase is never executed.

If set to **1** the direct current injection phase is executed when the stop command is sent and the speed reference threshold = zero has been reached.

Example:

With the motor running at any speed, when the stop command is enabled the ramp output decreases according to the selected ramp time. When the speed reference threshold = zero is reached **PAR 934 Ref is 0 = 0** the direct current injection phase is enabled and direct current injection starts after a delay set in **PAR 3154 DC brake delay**. **PAR 3156 DC brake duration** is used to configure the duration of the injection phase and **PAR 3158 DC brake current** is used to configure the intensity of the injection phase current.

In "On Command" mode the direct current injection phase is executed when the **DC braking cmd** configured using parameter **PAR 3150 DC braking cmd src** is sent.

Example:

Motor running driven by load. When the drive is enabled and the **DC braking cmd** is sent the direct current injection phase is activated. When the command is enabled and after the delay configured in **PAR 3154 DC brake delay** direct current injection starts. **PAR 3156 DC brake duration** is used to configure the duration of the injection phase and **PAR 3158 DC brake current** is used to configure the intensity of the injection phase current.

If the command is an impulse shorter than the time set with **PAR 3156 Durata frenatura DC**, the direct cur-

rent injection phase continues at least for the time set in parameter **3156 DC brake duration**.

If the command is an impulse longer than the time set with **3156 DC brake duration**, the direct current injection phase continues for as long as the command is present.

In “**OnCmd & AtStop**” modes the direct current injection phase is executed when one of the two conditions described in the “**At Stop**” or “**On Command**” modes is present.

Menu	PAR	Description	UM	Type	FB BIT	Def	Min	Max	Acc	Mod
22.3.3	3154	DC brake delay	s	FLOAT		0.5	0.01	30.0	ERW	VS

This parameter is used to configure the delay in seconds between the moment DC braking is requested and the moment direct current injection starts. This delay enables the motor to demagnetise, and thus avoid an overcurrent due to the electromotive force of the motor (e.f.m.).

The value of this parameter, added to parameter 3156 **DC brake duration**, must be lower than the value of parameter 1006 **Speed 0 disable dly**, otherwise direct current injection will stop when the drive is disabled.

Menu	PAR	Description	UM	Type	FB BIT	Def	Min	Max	Acc	Mod
22.3.4	3156	DC brake duration	s	FLOAT		1.0	0.01	30.0	ERW	VS

This parameter is used to configure the duration of direct current injection in the stator windings.

The value of this parameter, added to parameter 3154 **DC brake delay**, must be lower than the value of parameter 1006 **Speed 0 disable dly**, otherwise direct current injection will stop when the drive is disabled.

Menu	PAR	Description	UM	Type	FB BIT	Def	Min	Max	Acc	Mod
22.3.5	3158	DC brake current	perc	FLOAT		50.0	0.0	150.0	ERW	VS

This parameter is used to configure the value of the injected direct current.

It is expressed as a percentage of the drive continuous current (PAR **488 Drive cont current**).

Menu	PAR	Description	UM	Type	FB BIT	Def	Min	Max	Acc	Mod
22.3.6	3160	DC brake state		ENUM	16	Non active	0	1	ER	VS

The status of direct current braking is displayed.

- 0 Non active
- 1 Active

Note !

During the direct current injection phase the **Enable** command should not be enabled. If the **Enable** command is sent to the drive, the ramp output starts following the set reference; direct current output is produced in any case. The moment the **DC braking cmd** is removed there is immediately a speed step without performing a change in the ramp.

During the direct current injection phase, for the **Jog** command follow the instructions provided for the **Enable** command.

22.4 – FUNCTIONS/MOTOR OVERLOAD

The overload control function provides integrator logic to protect the motor against thermal overload. This protection presents the characteristic I^2t behaviour and is an emulation of the thermal relay of the motor controlled by the ADV drive.

When the function is enabled, the value reached by the integrator is stored each time the drive is switched off. The saved value is restored each time the drive is switched on.

I²tm Overload time – PAR 3216 Motor Fan type = (1) Servo fan
I²tm Overload time - PAR 3216 Motor Fan type = (0) Auto fan - PAR 260 Motor speed > PAR 2004 Rated Speed

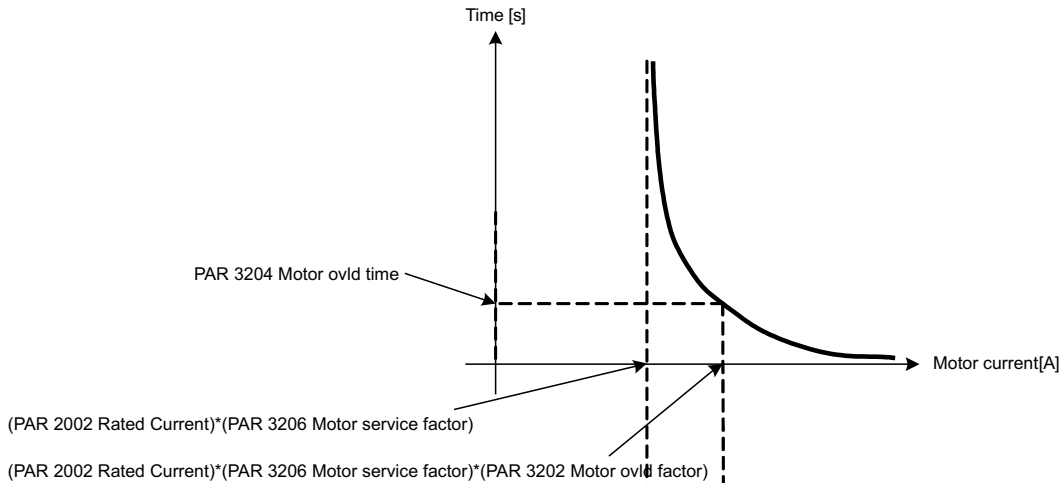

I²tm Overload time – PAR 3216 Motor Fan type = (1) Servo fan
I²tm Overload time - PAR 3216 Motor Fan type = (0) Auto fan - PAR 260 Motor speed > PAR 2004 Rated Speed

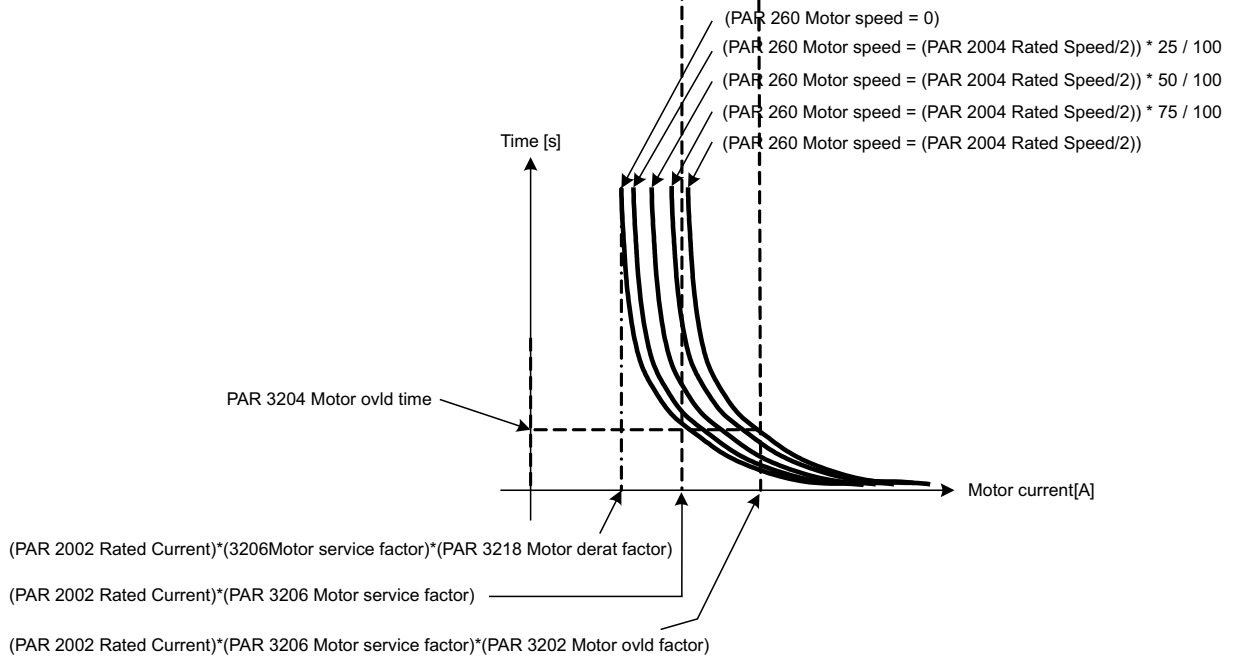

Menu	PAR	Description	UM	Type	FB BIT	Def	Min	Max	Acc	Mod
22.4.1	3200	Motor ovlid enable		BIT		0	0	1	ERW	VS

Enabling of the motor overload control.

0 Disable

1 Enable

If set to **0** the MOTOR OVERLOAD function is disabled.

If set to **1** the MOTOR OVERLOAD function is enabled.

Menu	PAR	Description	UM	Type	FB BIT	Def	Min	Max	Acc	Mod
22.4.2	3202	Motor ovlid factor	perc	FLOAT		150.0	100.0	300.0	ERWS	VS

Setting of the motor overload value. The value is expressed as a percentage of **Rated current** (PAR 2002) * **Motor service factor** (PAR 3206).

The current obtained from **Rated current** (PAR 2002) * **Motor service factor** (PAR 3206) * **Motor ovlid factor** (PAR 3202) is the maximum current that can circulate in the motor.

If the MOTOR OVERLOAD function is enabled the drive automatically sets the torque current limit so that lout max. does not exceed this value. The MOTOR OVERLOAD function can be used to deliver current to the motor at the overload value for a time set in **Motor ovlid time** (PAR 3204). After the set time, the MOTOR OVERLOAD function automatically sets the torque current limit so that lout max. does not exceed **Rated current** (PAR 2002) * **Motor service factor** (PAR 3206).

If the value of parameter 3202 **Motor ovlid factor** is 100 % the overload current of the Motor Overload function is equal to the continuous current of the Motor Overload function. In this case the drive behaves as if the overload cycle has been executed and so sets the torque current limit so that lout max. is not more than the continuous current, i.e. **Rated current** (PAR 2002) * **Motor service factor** (PAR 3206).

Menu	PAR	Description	UM	Type	FB BIT	Def	Min	Max	Acc	Mod
22.4.3	3204	Motor ovlid time	s	FLOAT		30.0	10.0	300.0	ERWS	VS

Setting of the motor overload duration in seconds.

With the MOTOR OVERLOAD function a current equal to the level of **Rated current** (PAR 2002) * **Motor service factor** (PAR 3206) * **Motor ovlid factor** (PAR 3202) is supplied to the motor for the time set in **Motor ovlid time** (PAR 3204).

The MOTOR OVERLOAD protection intervention time depends on the level of current circulating in the motor, a current equal to the overload level is allowed for the time set in **Motor ovlid time** a current at below the overload level is allowed for longer.

This alarm can be assigned to a programmable digital output (**Motor overload trip**).

The trip time depends on the motor current value, see figure on previous page.

Menu	PAR	Description	UM	Type	FB BIT	Def	Min	Max	Acc	Mod
22.4.4	3206	Motor service factor	perc	FLOAT		100.0	25.0	200.0	ERWS	VS

Setting of the motor service factor. The value is expressed as a percentage of **Rated current** (PAR 2002).

Rated current (PAR 2002) * Motor service factor (PAR 3206) is the point at which the integrator logic is enabled.

The current obtained from **Rated current** (PAR 2002) * **Motor service factor** (PAR 3206) * **Motor ovlid factor** (PAR 3202) is the maximum current that can circulate in the motor.

If the MOTOR OVERLOAD function is enabled the drive automatically sets the torque current limit so that lout max. does not exceed this value. The MOTOR OVERLOAD function can be used to deliver current to the motor at the overload value for a time set in **Motor ovlid time** (PAR 3204). After the set time, the MOTOR OVERLOAD function automatically sets the torque current limit so that lout max. does not exceed **Rated current** (PAR 2002) * **Motor service factor** (PAR 3206).

Menu	PAR	Description	UM	Type	FB BIT	Def	Min	Max	Acc	Mod
22.4.5	3216	Motor fan type		ENUM		Servo fan	0	1	ERW	VS

This parameter is used to set the type of motor cooling system.

0 Auto fan

1 Servo fan

Auto fan indicates the presence of a fan unit mounted on the motor shaft that therefore turns at a speed proportional to the motor speed. Cooling is not very effective at low motor speeds.

Servo fan indicates the presence of an independent fan unit that therefore always runs at the rated speed. It ensures optimum cooling efficiency at all motor speeds.

When the current motor speed is below (PAR 2004 **Rated speed** / 2) and PAR 3216 **Motor fan type** = Auto fan; , the MOTOR OVERLOAD protection intervention time must be reduced as cooling is insufficient.

At below (PAR 2004 **Rated speed** / 2) the protection intervention time is reduced by reducing the direct current of the MOTOR OVERLOAD function.

When the motor speed is equal to (PAR 2004 **Rated speed** / 2) the direct current of the MOTOR OVERLOAD function is equal to PAR 2002 **Rated current** * PAR 3206 **Motor service factor**, , whereas below that limit it is modified following a linear pattern until PAR 2002 **Rated current** * 3206 **Motor service factor** * PAR 3218 **Motor derat factor** when the motor speed reaches zero.

The overload current of the MOTOR OVERLOAD function is obtained by PAR 2002 **Rated current** * 3206 **Motor service factor** * PAR 3202 **Motor ovld factor** and is the maximum current that can circulate in the motor. If the MOTOR OVERLOAD function is enabled the drive automatically sets the torque current limit so that lout max. does not exceed this value.

With the MOTOR OVERLOAD function a current equal to the Overload level is supplied to the motor for the maximum time set in PAR 3204 **Motor ovld time**, The slower the motor speed, the shorter the time allowed (see figure at beginning of chapter).

After the set time, the MOTOR OVERLOAD function automatically sets the torque current limit so that lout max. does not exceed the direct current of the MOTOR OVERLOAD function.

When the motor current speed exceeds (PAR 2004 **Rated speed** / 2) and PAR 3216 **Motor fan type** = Auto fan, the direct current is not reduced as cooling is sufficient.

When PAR 3216 **Motor fan type** = Servo fan, the direct current is not reduced as cooling is sufficient.

Menu	PAR	Description	UM	Type	FB BIT	Def	Min	Max	Acc	Mod
22.4.6	3218	Motor derat factor	perc	FLOAT		50.0	0.0	100.0	ERWS	VS

This parameter is used to set the derating factor. The value is expressed as a percentage of PAR 2002 **Rated current** * PAR 3206 **Motor service factor**.

When the current motor speed is below (PAR 2004 **Rated speed** / 2) and PAR 3216 **Motor fan type** = Auto fan, the protection intervention time must be reduced as cooling is insufficient.

At below (PAR 2004 **Rated speed** / 2) sthe protection intervention time is reduced by reducing the direct current of the MOTOR OVERLOAD function.

When the motor speed is equal to (PAR 2004 **Rated speed** / 2)) the direct current of the MOTOR OVERLOAD function is equal to PAR 2002 **Rated current** * PAR 3206 **Motor service factor**, whereas below that limit it is modified following a linear pattern until PAR 2002 **Rated current** * PAR 3206 **Motor service factor** * PAR 3218 **Motor derat factor** when the motor speed reaches zero.

The overload current of the MOTOR OVERLOAD function is obtained by PAR 2002 **Rated current** * PAR 3206 **Motor service factor** * PAR 3202 **Motor ovld factor** and is the maximum current that can circulate in the motor. If the MOTOR OVERLOAD function is enabled the drive automatically sets the torque current limit so that lout max. does not exceed this value.

With the MOTOR OVERLOAD function a current equal to the Overload level is supplied to the motor for the maximum time set in PAR 3204 **Motor ovld time**, The slower the motor speed, the shorter the time allowed (see graphs).

After the set time, the MOTOR OVERLOAD function automatically sets the torque current limit so that lout max. does not exceed the direct current of the MOTOR OVERLOAD function.

When the motor current speed exceeds (PAR 2004 **Rated speed** / 2) and PAR 3216 **Motor fan type** = Auto fan, the direct current is not reduced as cooling is sufficient.

When PAR 3216 **Motor fan type** = Servo fan, the direct current is not reduced as cooling is sufficient.

If the value of parameter 3202 **Motor ovld factor** is 100 % the overload current of the Motor Overload function is equal to the continuous current of the Motor Overload function. In this case the drive behaves as if the overload cycle has been executed and so sets the torque current limit so that lout max is not more than the continuous current, i.e. **Rated current** (PAR 2002) * **Motor service factor** (PAR 3206) * **Motor derat factor** (PAR 3218).

We recommend setting parameter 3218 **Motor derat factor** to a value so that **Rated current** (PAR 2002) * **Motor service factor** (PAR 3206) * **Motor derat factor** (PAR 3218) produces a result that is more than the motor magnetisation current.

22.5 – FUNCTIONS/BRES OVERLOAD



Braking resistors may be subject to sudden overloads following failures.
Always protect resistors by using thermal protection devices.

These devices do not have to interrupt the circuit where the resistor is installed, but their auxiliary contact must interrupt the power supply of the drive power section. If the resistor requires the presence of a protection contact, this must be used together with the one belonging to the thermal protection device.

Menu	PAR	Description	UM	Type	FB BIT	Def	Min	Max	Acc	Mod
22.5.1	3250	Bres control		BIT		0	0	1	ERWZ	VS
Enabling of the overload control of the external braking resistor.										

Menu	PAR	Description	UM	Type	FB BIT	Def	Min	Max	Acc	Mod
22.5.2	3252	Bres value	ohm	FLOAT		SIZE	7.0	1000.0	ERWS	VS
Setting of the ohm value of the external braking resistor.										

Menu	PAR	Description	UM	Type	FB BIT	Def	Min	Max	Acc	Mod
22.5.3	3254	Bres cont power	kW	FLOAT		SIZE	0.1	100.0	ERWS	VS
Setting of the power that can be continuously dissipated by the external braking resistor.										

Menu	PAR	Description	UM	Type	FB BIT	Def	Min	Max	Acc	Mod
22.5.4	3256	Bres overload factor		FLOAT		SIZE	1.5	10.0	ERWS	VS
Setting of the external resistor overload factor.										

Menu	PAR	Description	UM	Type	FB BIT	Def	Min	Max	Acc	Mod
22.5.5	3258	Bres overload time	s	FLOAT		SIZE	0.5	50.0	ERWS	VS
Setting of the intervention time of the external braking resistor overload.										

22.6 – FUNCTIONS/SPEED CAPTURE

This function allows the drive to capture a motor running due to inertia or driven by the load. The function is also enabled in case of an automatic restart after an alarm condition.

Main fields of application:

- Capturing a motor set in motion by the load (for example pump motors driven by the fluid)
- Capturing a motor connected directly to the power mains
- Capturing a motor running due to temporary disabling of the drive
- Capturing a motor that is running in the case of an automatic restart after an alarm

Note ! If the drive is enabled with the motor running and this function disabled, the drive could be blocked due to the intervention of the Overcurrent or Undercurrent protections

Menu	PAR	Description	UM	Type	FB BIT	Def	Min	Max	Acc	Mod
22.6.1	3350	Speed capture		ENUM		Disable	0	1	ERW	FV_

This parameter is used to enable the function to capture a motor that is running.

- 0 Disable
- 1 Alarm restart
- 2 Enable&restart

If set to **0** the capture running motor function is disabled. The output frequency starts from 0 and passes to the set reference value using the ramp.

If set to **1** the capture running motor function is executed at restart each time an alarm is automatically reset.

If set to **2** the capture running motor function is executed each time the drive is enabled and each time an alarm is automatically reset.

This function is available with **Regulation mode = V/f control**.

This function is not available with **Regulation mode = Flux vector OL**.

With **Regulation mode = Flux vector CL** the capture procedure consists of forcing the output frequency to the

With **Regulation mode = V/f control** the capture procedure consists of altering the inverter output frequency until the actual motor speed is detected, then increasing the motor speed to the reference value using the ramp. The procedure can take several seconds, depending on the type of load and parameter settings. If this function is enabled on a motor at speed = 0 and drive speed reference = 0, the motor might start running until the moment the drive detects the actual motor speed, after which the motor speed passes to the speed reference setting, i.e. 0. The initial value of the output frequency depends on the condition that generated the capture procedure. Various conditions are possible:

Condition	Frequency value
First enabling of the drive after power-on	Par 3364 Vf catch start freq
Drive enabled and demagnetising for a time > Par 3376 Vf catch lastref dly	Par 3364 Vf catch start freq
Drive enabled and demagnetising for a time < Par 3376 Vf catch lastref dly	Last frequency before disabling the drive
Automatic restart after an alarm	Last frequency before the alarm occurred

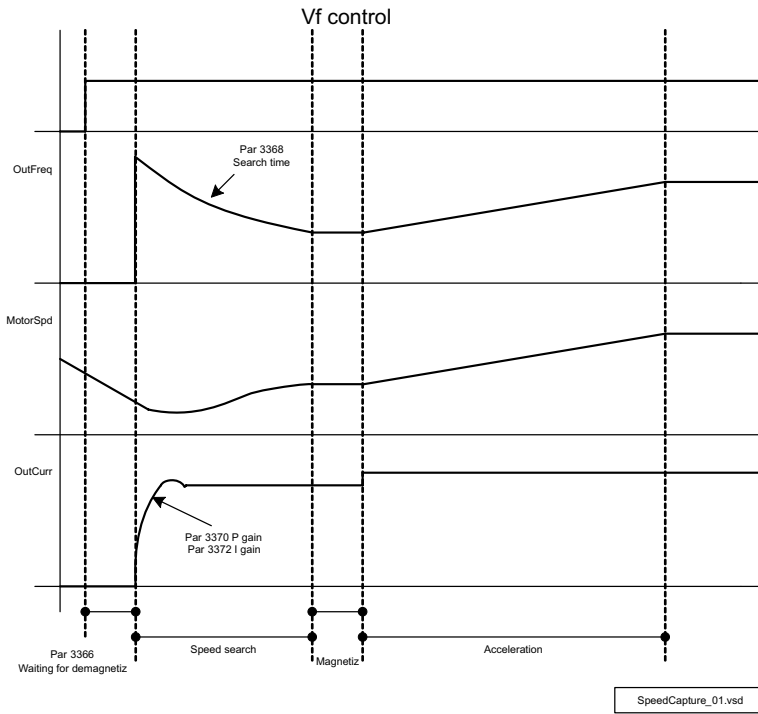

Menu	PAR	Description	UM	Type	FB BIT	Def	Min	Max	Acc	Mod
22.6.2	3364	Vf catch start freq	Hz	FLOAT		(*)	-500.0	500.0	ERWZ	V

(*) : EU = 50Hz; USA = 60 Hz.

This parameter is used to configure the frequency at which the procedure to capture a motor that is running starts. This parameter is used if:

Condition	Frequency value
First enabling of the drive after power-on	Par 3364 Vf catch start freq
Drive enabled and demagnetising for a time > Par 3376 Vf catch lastref dly	Par 3364 Vf catch start freq

This parameter must be set to a frequency that is higher than the frequency at which the motor is running at the beginning of the capture procedure. If the conditions are not always identical the maximum frequency or a few Hz below this must be set. The reference sign setting must be the same as the sign of the frequency at which the motor is running.

If a frequency value close to the actual frequency is set, the capture time is short. If there is a big difference between the frequency value setting and the actual frequency, the capture time is longer.

The recommended setting for this parameter is 0 if the function is enabled for use to capture a motor running due to a temporary disabling of the drive or to capture a motor running in the case of an automatic restart after an alarm; or in case of enabling after power-on or after prolonged periods of disabling, the motor speed is certainly 0.

Menu	PAR	Description	UM	Type	FB BIT	Def	Min	Max	Acc	Mod
22.6.3	3366	Vf catch enable dly	ms	UINT16		1000	10	10000	ERWZ	V

This parameter is used to configure the time to wait for demagnetisation of the motor before executing the procedure to capture the motor that is running. The waiting time for demagnetisation is measured starting from the moment the drive detects that the conditions are OK to execute the capture procedure. This parameter is useful for automatic restarts after an alarm.

If the motor flux is not zero when the enable command is sent the drive might generate the **Overcurrent** alarm.

The value to set depends on the size of the motor. Large motors have a high rotor time constant and therefore require a long demagnetisation time. Setting a higher value than necessary is not a problem.

Menu	PAR	Description	UM	Type	FB BIT	Def	Min	Max	Acc	Mod
22.6.4	3368	Vf catch search time	s	FLOAT		2.0	1.0	30.0	ERW	V

This parameter is used to configure the speed at which the output frequency changes for synchronisation with

the motor running. It represents the time in which the frequency would change from 50 Hz to zero if the output current were equal to the drive continuous current.

The default setting is correct for most applications.

Low values require high current levels but guarantee fast synchronisation.

High values require low current levels but synchronisation takes longer.

During the synchronisation procedure the motor may change its speed of rotation. The longer the synchronisation phase the more evident the change in the speed of rotation.

Menu	PAR	Description	UM	Type	FB BIT	Def	Min	Max	Acc	Mod
22.6.5	3370	Vf catch P gain	perc	FLOAT		10.0	0.0	100.0	ERW	V

This parameter is used to set the proportional gain of the current regulator used by the procedure to capture a motor that is running. Values that are too low could trigger the Overcurrent protection. Changing this value is not recommended.

Menu	PAR	Description	UM	Type	FB BIT	Def	Min	Max	Acc	Mod
22.6.6	3372	Vf catch I time	ms	UINT16		200	200	1000	ERW	V

This parameter is used to set the integral time of the current regulator used by the procedure to capture a motor that is running. Changing this value is not recommended.

Menu	PAR	Description	UM	Type	FB BIT	Def	Min	Max	Acc	Mod
22.6.7	3376	Vf catch lastref dly	ms	UINT16		0	0	30000	ERWZ	V

This parameter is used to set the time within which the drive must be enabled in order to start the capture procedure at the output frequency present before disabling the drive. If the time that elapses from the moment the drive is disabled exceeds the time set in this parameter, the capture procedure starts from the frequency set in parameter **3364 Vf catch start freq.**

22.7 – FUNCTIONS/POWER LOSS

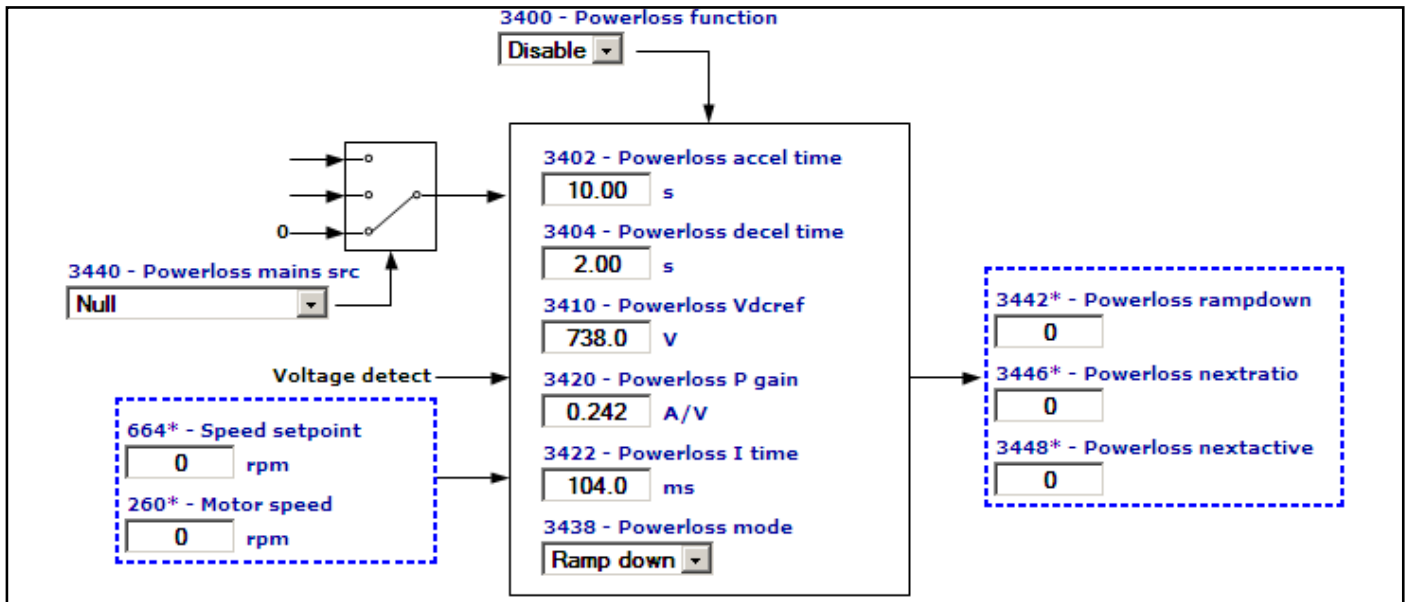

This function controls a loss of power or temporary mains failure.

When the function is enabled the system stops with the controlled ramp; the power regenerated by the load sustains the DC link power supply so that the motor speed can be controlled. The speed of the motor is controlled for as long as power can be recovered (motor speed almost zero but not zero), after which the **Under-voltage** alarm is generated and the motor performs an uncontrolled stop due to inertia.

The function is only effective with loads that accumulate sufficient energy (typically loads with a high moment of inertia and which the moment the power loss occurs have a speed of rotation not close to zero). The function cannot be used for passive loads.

The function can only be used with **Regulation mode = V/f control**.

The Powerloss function is enabled when the DC link voltage falls below a threshold configured internally as a function of the mains voltage at a value that is higher than the **Undervoltage** threshold. When the function is enabled the drive controls a stop with a user-definable deceleration ramp. In this phase the current limit is controlled by a regulator on the DC link voltage and the setpoint is a threshold configured internally as a function of the mains voltage at a value below the **Overvoltage** threshold.

The regulator envisages two setting parameters (proportional and integral) calculated in advance by the drive as a function of the size of the motor and plate data. If the regulator acts on the current limit the motor speed does not follow the set deceleration ramp. The function continues for as long as power can be recovered, after which the **Undervoltage** alarm is generated. If the mains supply is restored during the deceleration ramp phase, the user can configure how the drive should behave. The following options are available: continue in any case until reaching zero speed or stop the deceleration ramp and pass to the set reference.

The drive does not automatically recognise the fact that the mains supply has been restored. This information must be supplied from the outside via the **Powerloss mains src** digital input.

The presence of the braking unit prevents the intervention of the **Overvoltage** alarm and the function has the advantage of being able to stop the motor while guaranteeing the set time.

As the setpoint of the Powerloss function regulator is higher than the brake activation threshold, it is not enabled and the current limit is not altered to allow compliance with the set deceleration ramp time. The intervention of the braking unit dissipates the energy of the motor in the resistor, reducing the amount of power available to sustain the DC link and the time available to control stopping of the motor. The presence of the braking unit could mean that the speed of the motor from which no power can be recovered is higher than that with no braking unit.

The function can be used on machines with a single drive as well as on machines with several drives, the speeds of which must always be synchronised.

For machines with a single drive, enabling the Powerloss function is sufficient.

For machines with several drives, the DC links must be connected: the Powerloss function must only be enabled on the drive identified as the master and not on the slaves. The master drive is normally the one that controls the load with the highest inertia. The master drive sends the **Powerloss nexratio** signal with the

ratio between the motor speed and the speed reference. Line synchronisation can be achieved by connecting the **Powerloss nextratio** output of the master to the **Speed ratio src** input (selection list L_VREF) of the slave drives. The master => slave connection can be achieved via analog signals or fieldbus.

To ensure correct operation of the Powerloss function, the following alarms must be configured as described below:

Since the speed reference and current limit are controlled internally by the Powerloss function, a difference could occur between the speed reference and motor speed with subsequent activation of the **Perd Riferim** alarm: to avoid this, set Par **4552 SpdRefLoss activity = Ignore**

During the power failure, the power supply phase loss detection system might not work properly with subsequent activation of the **Phaseloss** alarm: to avoid this, set Par **4660 PhLoss activity=Ignore**.

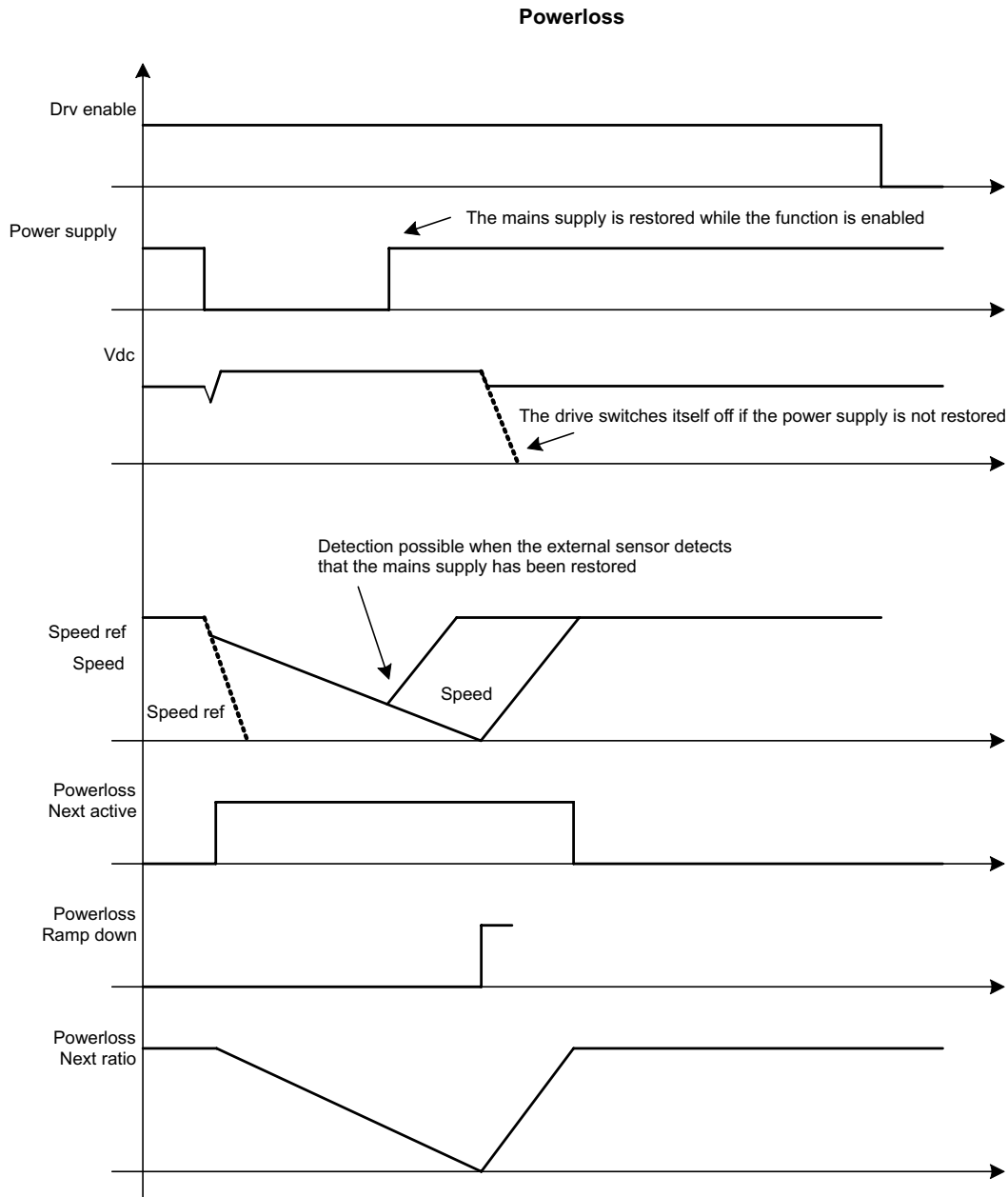

PowerLoss_01.vsd

Menu	PAR	Description	UM	Type	FB BIT	Def	Min	Max	Acc	Mod
22.7.1	3400	Powerloss function		ENUM		Disable	0	1		ERWZ F__

This parameter is used to enable the Powerloss function.

- 0 Disable
- 1 Enable

If set to **0** the Powerloss function is disabled. The Undervoltage alarm is generated in the event of a power failure.

If set to **1** the Powerloss function is enabled. In case of a power failure the function is enabled to try to control the motor speed and prevent the intervention of the **Undervoltage** alarm.

Menu	PAR	Description	UM	Type	FB BIT	Def	Min	Max	Acc	Mod
22.7.2	3402	Powerloss accel time	s	FLOAT		10.0	0.01	100.0	ERW	F__

Setting of the acceleration time used in the Powerloss operating mode. The acceleration ramp time is used when **Powerloss mode = Restart** has been selected and must be adjusted to suit machine requirements.

Menu	PAR	Description	UM	Type	FB BIT	Def	Min	Max	Acc	Mod
22.7.3	3404	Powerloss decel time	s	FLOAT		2.0	0.01	100.0	ERW	F__

Setting of the deceleration time used during Powerloss operating mode.

The deceleration ramp time must be short enough (in case of low speeds) to allow the drive to enter regeneration mode quickly, otherwise the **Undervoltage** alarm is generated. If the deceleration ramp time setting is too short, when the drive enters regeneration mode it might not be able to control the DC link voltage and the **Overvoltage** alarm would be generated.

Longer deceleration times are necessary at high motor speeds to prevent the **Overvoltage** alarm from being generated.

This parameter must be adjusted so as to reach a compromise between low speed and high speed motor operation.

Menu	PAR	Description	UM	Type	FB BIT	Def	Min	Max	Acc	Mod
22.7.4	3410	Powerloss Vdcref	V	FLOAT		CALCF	0.0	CALCF	ERWZSFV	_

Setting of the voltage control limit on the DC-link during a controlled stop with loss of supply voltage. The maximum value that can be set is the drive overvoltage limit.

Menu	PAR	Description	UM	Type	FB BIT	Def	Min	Max	Acc	Mod
22.7.5	3420	Powerloss P gain	A/V	FLOAT		CALCF	0	100000	ERWS	F__

Setting of the proportional gain during the Powerloss function.

Increase in case of **Overvoltage** error; the **Undervoltage** alarm can also be prevented by increasing the deceleration time.

Increase if the DC link voltage is set to a value other than the setpoint.

Menu	PAR	Description	UM	Type	FB BIT	Def	Min	Max	Acc	Mod
22.7.6	3422	Powerloss I gain	ms	FLOAT		CALCF	1.0	1000.0	ERWS	F__

Setting of the integral gain during the Powerloss function.

Reduce if the DC link voltage is set to a value other than the setpoint.

Menu	PAR	Description	UM	Type	FB BIT	Def	Min	Max	Acc	Mod
22.7.7	3438	Powerloss mode		ENUM		Ramp down	0	1	ERWZ	F__

This parameter is used to configure the behaviour of the Powerloss function when the mains supply is restored.

It is possible to set whether the drive should continue at zero speed or return to the setpoint when the mains supply is restored. The drive does not automatically recognise the fact that the mains supply has been restored. This information must be supplied from the outside via the **Powerloss mains src** digital input.

0 Ramp down

1 Restart

Example 1)

End of ramp and mains supply not restored

The drive controls a deceleration with the ramp set in **Powerloss decel time**.

The drive automatically controls the DC link voltage and prevents the **Overvoltage** alarm.

If the mains supply is not restored close to a speed of zero, when there is insufficient regenerated power, the **Undervoltage** alarm is generated and the drive may switch itself off.

Ramp down and mains supply not restored

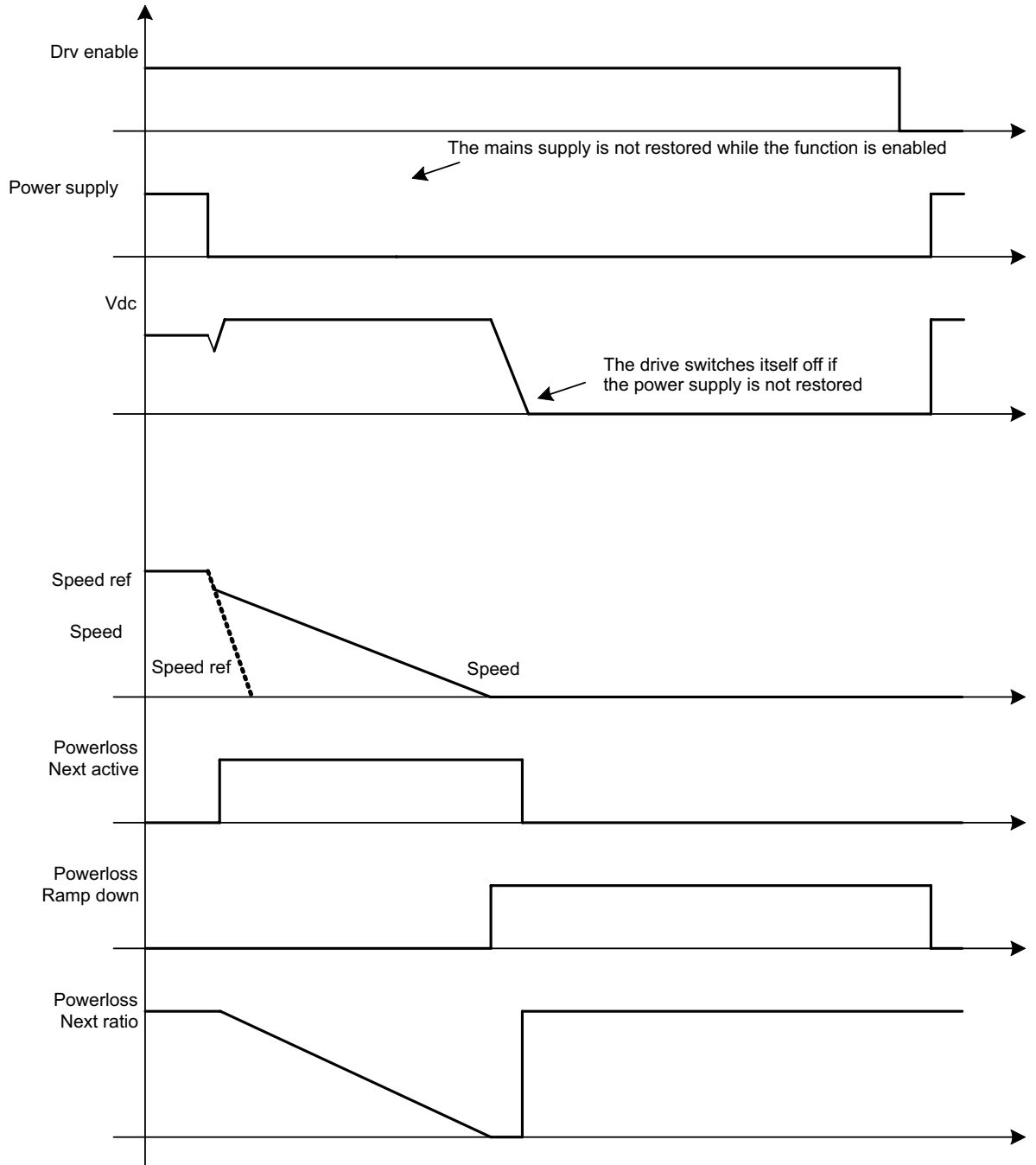

PowerLoss_02.vsd

Example 2)

End of ramp and mains supply restored

The drive controls a deceleration with the ramp set in **Powerloss decel time**.

The drive automatically controls the DC link voltage and prevents the **Overvoltage** alarm.

If the mains supply is restored and the **Mains voltage OK** signal is applied, the drive passes to zero speed and remains enabled at zero speed. To restart disable and enable the drive.

Ramp down and mains supply restored

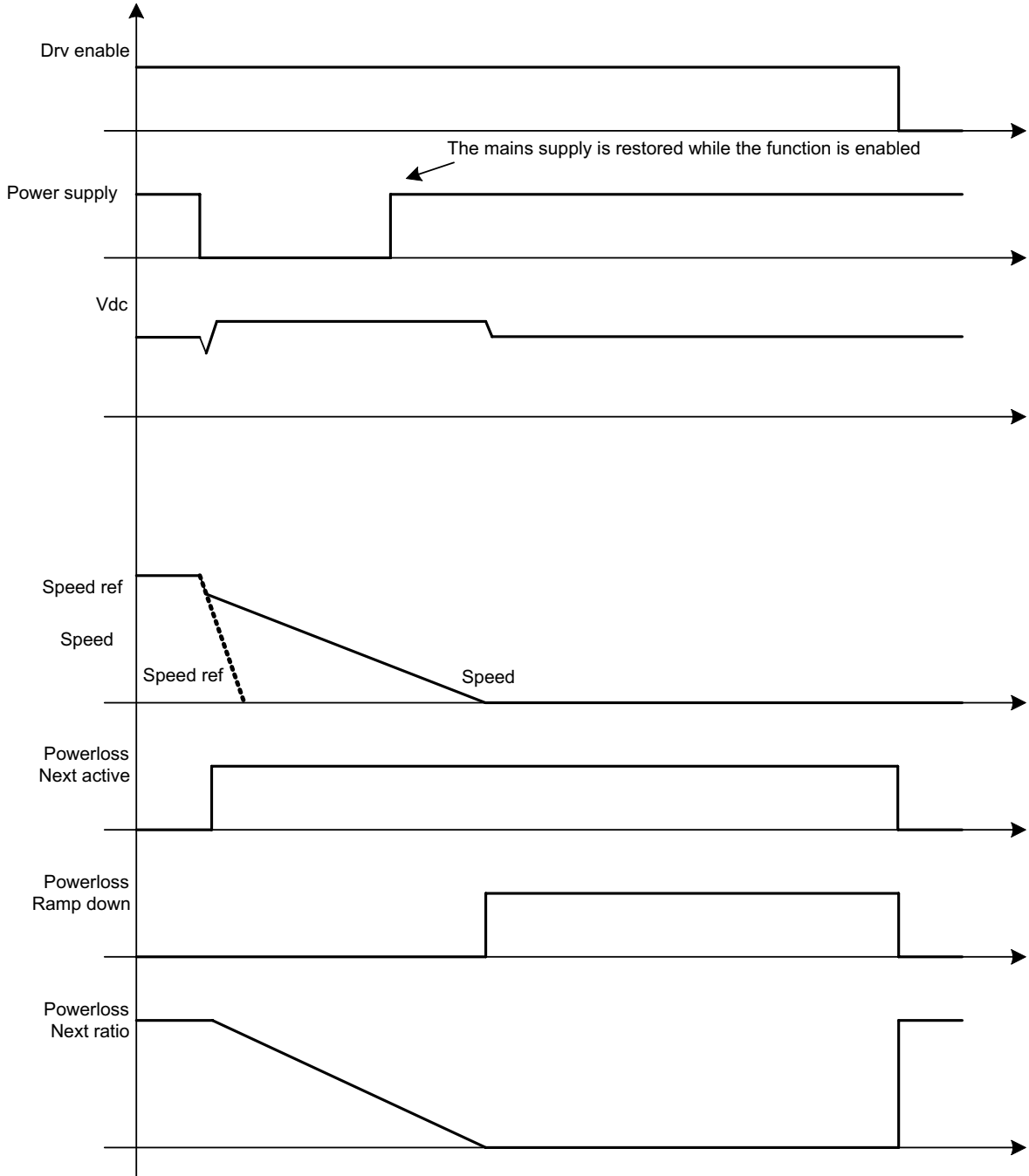

PowerLoss_03.vsd

Example 3)

Restart and mains supply not restored

The drive controls a deceleration with the ramp set in **Powerloss decel time**.

The drive automatically controls the DC link voltage and prevents the **Overvoltage** alarm.

If the mains supply is not restored close to a speed of zero, when there is insufficient regenerated power, the **Undervoltage** alarm is generated and the drive may switch itself off.

Restart and mains supply not restored

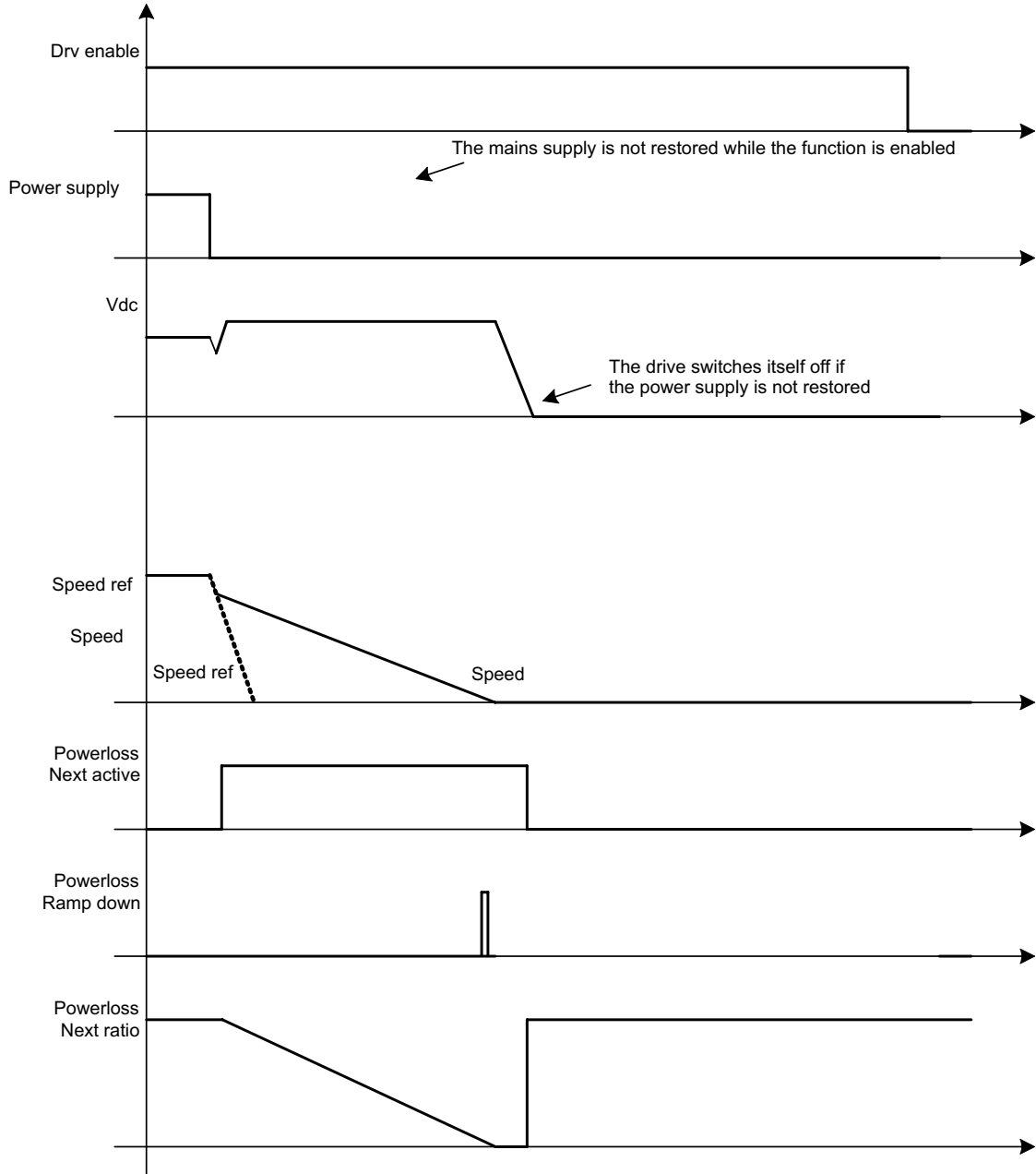

PowerLoss_04.vsd

Example 4)

Restart and mains supply restored

The drive controls a deceleration with the ramp set in **Powerloss decel time**.

The drive automatically controls the DC link voltage and prevents the **Overvoltage** alarm.

If the mains supply is restored and the **Mains voltage OK** signal is applied, the drive immediately stops the deceleration ramp and executes the acceleration ramp set in **Powerloss accel time** to pass to the set reference.

Restart and mains supply restored

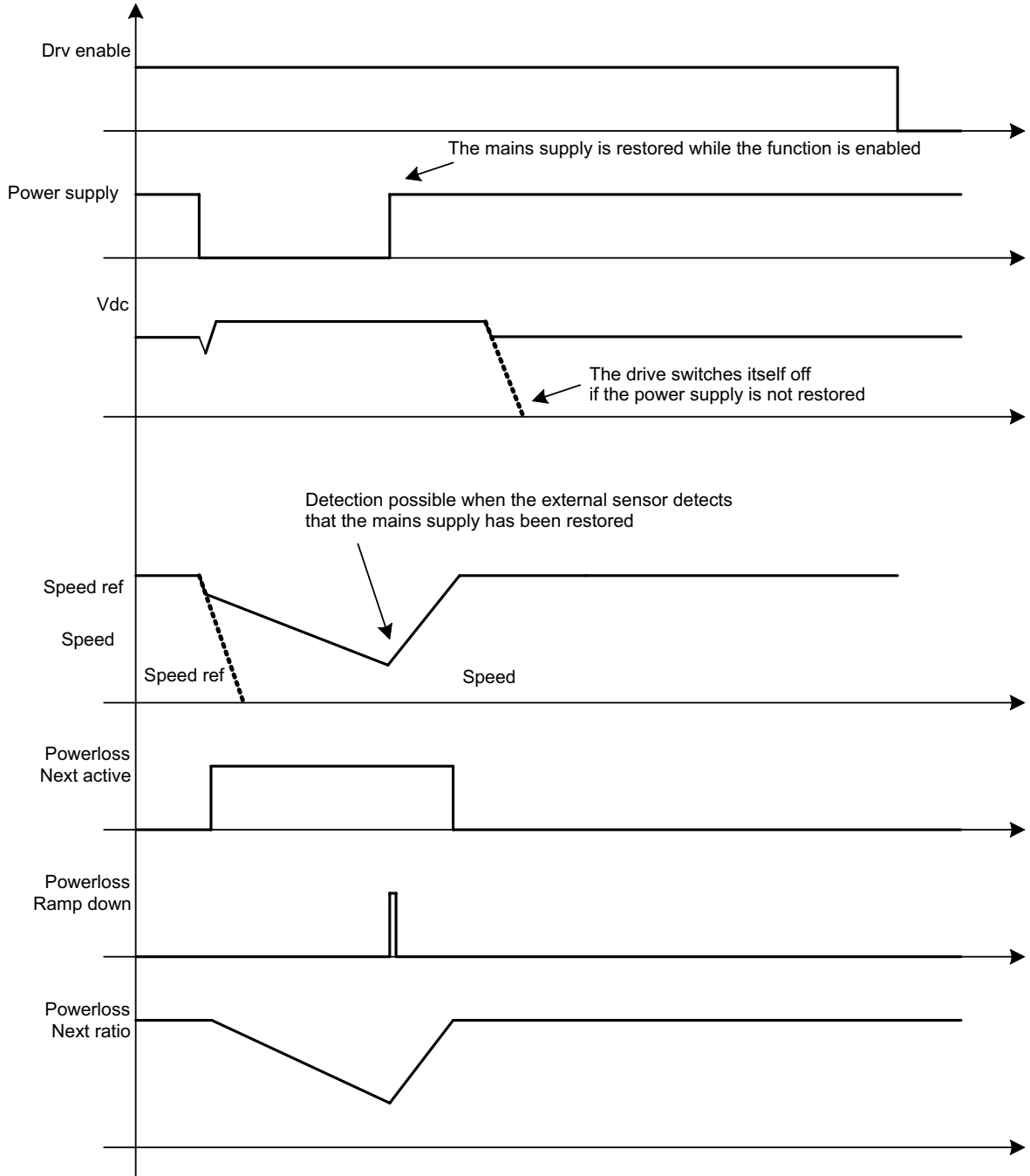

PowerLoss_05.vsd

Menu	PAR	Description	UM	Type	FB BIT	Def	Min	Max	Acc	Mod
22.7.8	3440	Powerloss mains src		LINK	16	6000	0	16384	ERWZ	F_

This parameter is used to select the origin (source) of the **Mains voltage OK** signal. The signal to be associated with this function can be selected from the "L_DIGSEL2" selection list.

If the signal is not enabled it means the power supply is not present (**Mains voltage not OK**), whereas if the signal is enabled it means the power supply is present (**Mains voltage OK**).

In the default condition the origin of the **Powerloss mains src** signal is **Zero**.

The user must connect an external sensor to inform the drive of the mains supply status.

If the function is configured as **Powerloss mode = Restart**, when the **Mains voltage OK** signal is enabled the drive stops the deceleration ramp and passes to the set reference.

For machines with several drives the external sensor signal must only be connected to the master drive.

22.8 – FUNCTIONS/COMPARE

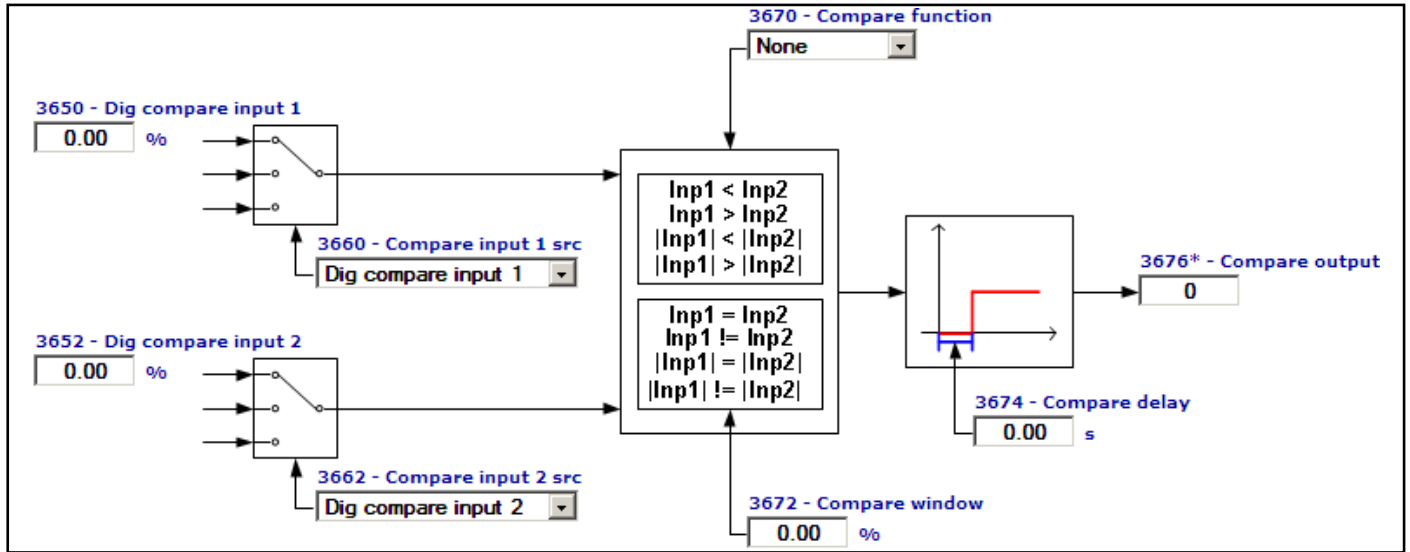

This function allows the comparison among two signals or values.

Menu	PAR	Description	UM	Type	FB BIT	Def	Min	Max	Acc	Mod
22.8.1	3650	Dig compare input 1	perc	FLOAT	32	0.0	-100.0	100.0	ERW	VS

Setting of the digital value of the first element of comparison.

Menu	PAR	Description	UM	Type	FB BIT	Def	Min	Max	Acc	Mod
22.8.2	3652	Dig compare input 2	perc	FLOAT	32	0.0	-100.0	100.0	ERW	VS

Setting of the digital value of the second element of comparison.

Menu	PAR	Description	UM	Type	FB BIT	Def	Min	Max	Acc	Mod
22.8.3	3660	Compare input 1 src		LINK	32	3650	0	16384	ERW	VS

Selection of the origin (source) of the signal to be used as the first term of comparison. The values that can be selected in the compare function are listed in the "**L_CMP**" selection list.

Menu	PAR	Description	UM	Type	FB BIT	Def	Min	Max	Acc	Mod
22.8.4	3662	Compare input 2 src		LINK	32	3652	0	16384	ERW	VS

Selection of the origin (source) of the signal to be used as the second term of comparison. The values that can be selected in the compare function are listed in the "**L_CMP**" selection list.

Menu	PAR	Description	UM	Type	FB BIT	Def	Min	Max	Acc	Mod
22.8.5	3670	Compare function		ENUM		None	0	8	ERW	VS

Setting of the compare function between **Compare input 2** and **Compare input 1** to enable **Cmp output**.

0 None

- 1 Inp1=Inp2
- 2 Inp1!=Inp2
- 3 Inp1<Inp2
- 4 Inp1>Inp2
- 5 |Inp1|=|Inp2|
- 6 |Inp1|!=|Inp2|
- 7 |Inp1|<|Inp2|
- 8 |Inp1|>|Inp2|

If set to **0** the comparator is not enabled

If set to **1** the comparator output is enabled when the value of **Compare digital inp 1** is inside the window resulting from the value of **Compare digital inp 2** ± the tolerance set via the **Comparator Window**.

If set to **2** the comparator output is enabled when the value of **Compare digital inp 1** is not inside the window resulting from the value of **Compare digital inp 2** ± the tolerance set via the **Comparator Window**.

If set to **3** the comparator output is enabled when **Compare input 1** is less than **Compare input 2**.

If set to **4** the comparator output is enabled when **Compare input 1** is greater than **Compare input 2**.

If set to **5** the comparator output is enabled when the value of **Compare digital inp 1** is inside the window resulting from the absolute value of **Compare digital inp 2** ± the tolerance set via the **Comparator Window**.

If set to **6** the comparator output is enabled when the absolute value of **Compare digital inp 1** is not inside the window resulting from the absolute value of **Compare digital inp 2** ± the tolerance set via the **Comparator Window**.

If set to **7** the comparator output is enabled when the absolute value of **Compare digital inp 1** is less than the absolute value of **Compare digital inp 2**.

If set to **8** the comparator output is enabled when the absolute value of **Digital compar inp1** is more than the absolute value of **Digital compar in2**.

Menu	PAR	Description	UM	Type	FB BIT	Def	Min	Max	Acc	Mod
22.8.6	3672	Compare window	perc	FLOAT		0.0	0.0	100.0	ERW	VS

Setting of the tolerance window for comparing the **Compare input 1** and **Compare input 2** signals.

Menu	PAR	Description	UM	Type	FB BIT	Def	Min	Max	Acc	Mod
22.8.7	3674	Compare delay	s	FLOAT		0.0	0.0	30.0	ERW	VS

Setting of the delay for signalling the result of the comparison.

Menu	PAR	Description	UM	Type	FB BIT	Def	Min	Max	Acc	Mod
22.8.8	3676	Compare output		BIT	16	0	0	1	ER	VS

The status of the comparator output is displayed:

- 0 The result of the set comparison is negative
- 1 The result of the set comparison is positive

22.9 – FUNCTIONS/PADS

The general variables are used to exchange data between the various components of a Bus system. They are similar to the variables of a PLC. The basic structure of the system is illustrated below. Pads can be used, for example, to send information from a fieldbus to an optional card. All Pads can be read and written.

The Pads can also be used to exchange data with an MDPIc application installed in the drive. See the MDPIc manual for more details.

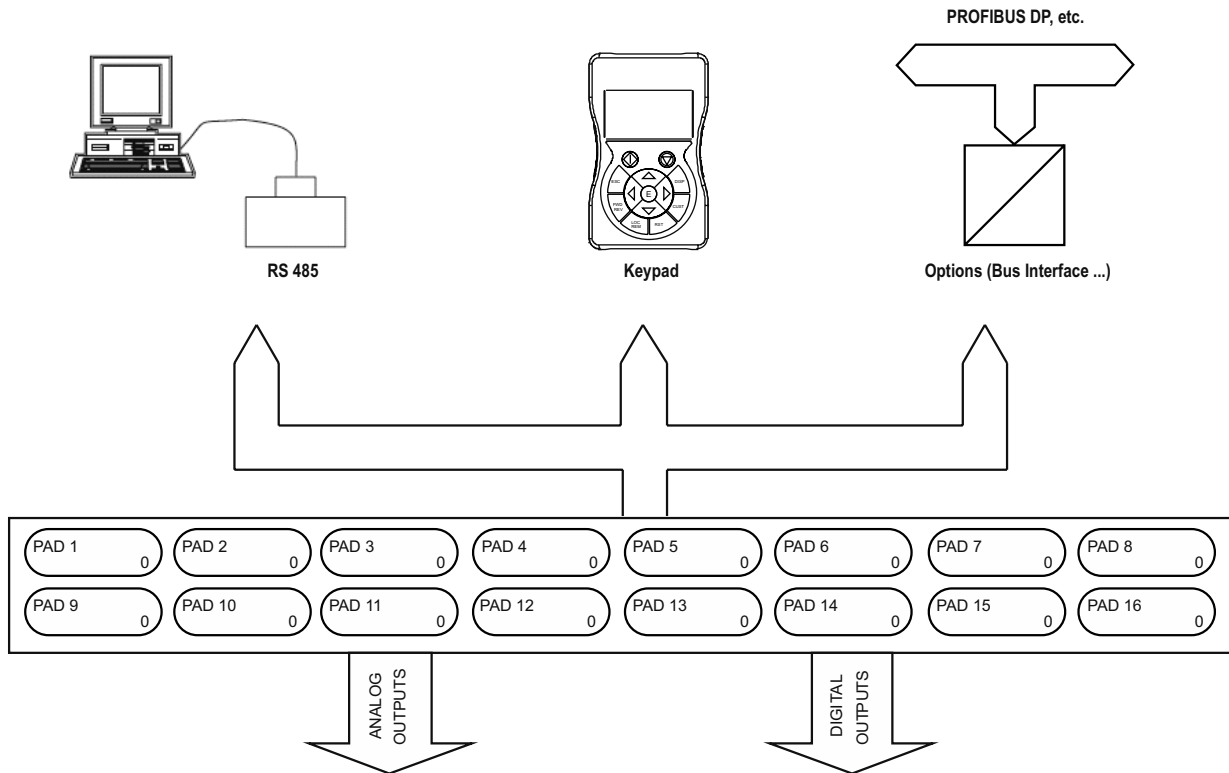

Menu	PAR	Description	UM	Type	FB BIT	Def	Min	Max	Acc	Mod
22.9.1	3700	Pad 1		INT32	32	0	0	0	ERW	VS
22.9.2	3702	Pad 2		INT32	32	0	0	0	ERW	VS
22.9.3	3704	Pad 3		INT32	32	0	0	0	ERW	VS
22.9.4	3706	Pad 4		INT32	32	0	0	0	ERW	VS
22.9.5	3708	Pad 5		INT32	32	0	0	0	ERW	VS
22.9.6	3710	Pad 6		INT32	32	0	0	0	ERW	VS
22.9.7	3712	Pad 7		INT32	32	0	0	0	ERW	VS
22.9.8	3714	Pad 8		INT32	32	0	0	0	ERW	VS
22.9.9	3716	Pad 9		INT32	32	0	0	0	ERW	VS
22.9.10	3718	Pad 10		INT32	32	0	0	0	ERW	VS
22.9.11	3720	Pad 11		INT32	32	0	0	0	ERW	VS
22.9.12	3722	Pad 12		INT32	32	0	0	0	ERW	VS
22.9.13	3724	Pad 13		INT32	32	0	0	0	ERW	VS
22.9.14	3726	Pad 14		INT32	32	0	0	0	ERW	VS
22.9.15	3728	Pad 15		INT32	32	0	0	0	ERW	VS
22.9.16	3730	Pad 16		INT32	32	0	0	0	ERW	VS

Setting of general, 32 Bit variables. PAD parameters can be used as supporting parameters to send values written by the fieldbus, serial line, etc. to analog or digital outputs.

22.10 - FUNCTIONS/VDC CONTROL

This function is used to control the voltage and power recovered in the DC link during regeneration (e.g. braking ramp). When this function is enabled, if the power regenerated by the load during braking increases the DC link voltage, the drive prevents triggering of the **Overvoltage** alarm by limiting the regenerated current.

The **Vdc control function** is enabled automatically (if parameter **3450 Vdc control function** is set to 1) when the DC link voltage exceeds a preset threshold, depending on the mains voltage and lower than the **Overvoltage** threshold.

This threshold is also used for the regulator that controls the regenerated current limit.

If the **Vdc control function** is enabled, the motor speed need not follow the set ramp.

If the regulator is unable to limit the regenerated power during the deceleration ramp and prevent the **Overvoltage** alarm from being generated, the ramp can be temporarily blocked by setting parameter **754 Ramp freeze src** using the information in **Vdc ctrl ramp freeze**.

The function remains enabled until the power regenerated by the load is cancelled and the DC link voltage falls below the disable threshold (below the enable threshold).

Menu	PAR	Description	UM	Type	FB BIT	Def	Min	Max	Acc	Mod
22.10.1	3450	Vdc control function		ENUM		Disable	0	1	ERWZ	VS

This parameter is used to enable the **Vdc control function**.

0 Disable

1 Enable

If set to **0** the function is disabled: in case of power recovery the Sovratensione alarm is generated.

If set to **1** the function is enabled: in case of power recovery the function is enabled and attempts to control the current regenerated by the motor and prevent the **Overvoltage** alarm from being generated.

Menu	PAR	Description	UM	Type	FB BIT	Def	Min	Max	Acc	Mod
22.10.21	3470	Vdc control P gain	A/V	FLOAT		CALCF	0.0	100.000	ERWS	VS

Setting of the proportional gain used during the **Vdc control function**. The set value must be increased if the **Overvoltage** alarm is generated. The Sovratensione alarm can also be prevented by lengthening the deceleration ramp. The value of this parameter must also be increased if the DC link voltage is set to a value other than the setpoint

Menu	PAR	Description	UM	Type	FB BIT	Def	Min	Max	Acc	Mod
22.10.3	3472	Vdc control I time	ms	FLOAT		CALCF	1.0	1000.0	ERWS	VS

Setting of the integral time used during the **Vdc control function**. The set value must be reduced if the DC link voltage is set to a value other than the setpoint.

22.11 - FUNCTIONS/BRAKE CONTROL

This function is used to control the motor parking brake. When the drive receives the **Start** command it releases the brake immediately. To make sure that the brake has actually been released, the references are disabled for a time that can be set in parameter **3172 Brake open delay**.

When the drive receives a stop command and the **Ref is 0** signal, it applies the parking brake after a time that can be set in parameter **3174 Brake close delay**. Set parameter **3174 Brake close delay** to a high enough value to be sure the motor has actually stopped before enabling the brake.

If this function is enabled, the brake is applied immediately if one or more alarms occur or if the drive is disabled. Do not use the **Brake control** and the **Speed Capture** functions together, as the latter, if enabled before the Start command, attempts to execute synchronisation with the motor speed and with the brake closed.

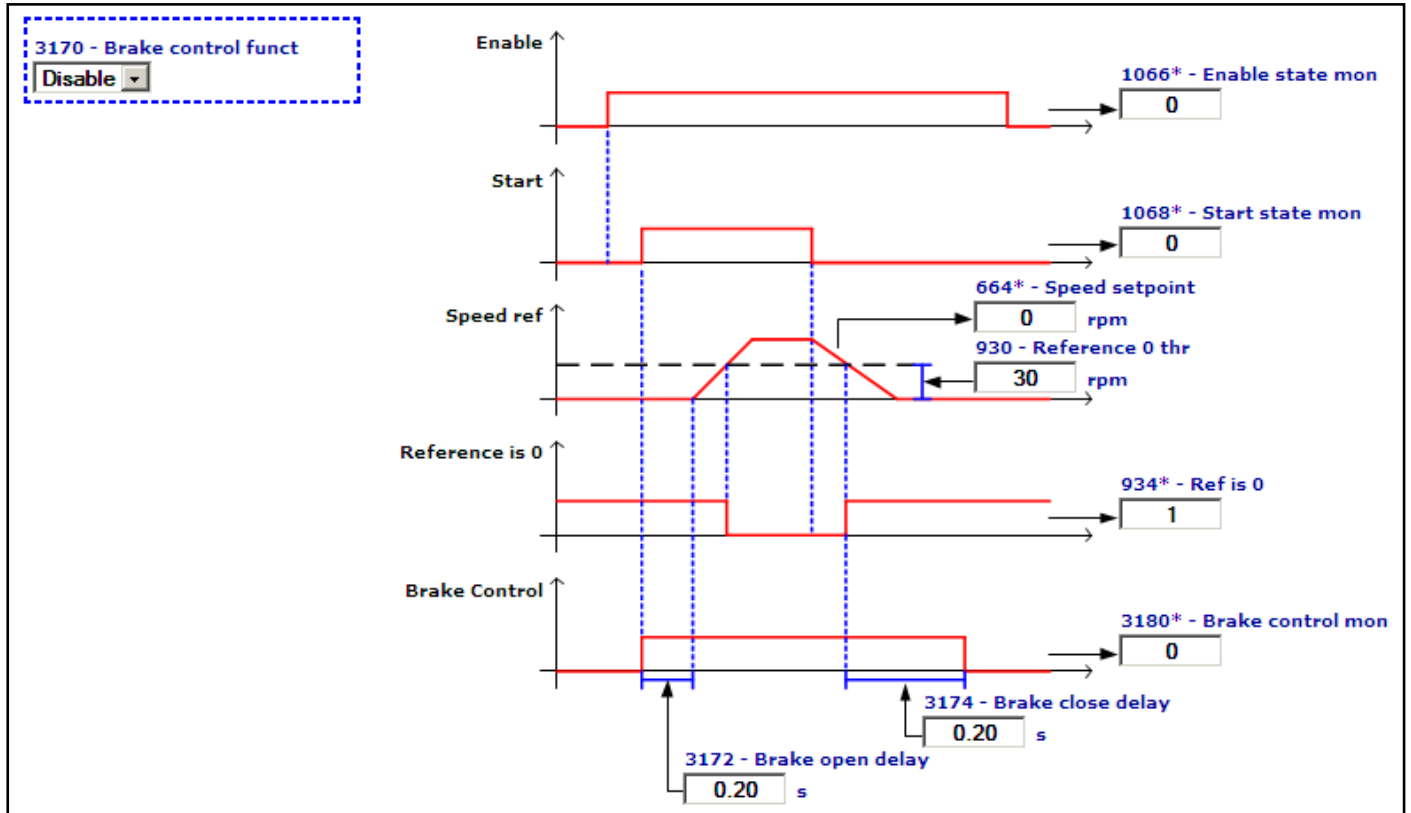

Menu	PAR	Description	UM	Type	FB BIT	Def	Min	Max	Acc	Mod
22.11.1	3170	Brake control funct		ENUM		Disable	0	1	ERWZ	VS

This parameter is used to enable the **Brake control funct**.

- 0 Disable
- 1 Enable

If set to **0** the function is disabled:
If set to **1** the function is enabled.

Menu	PAR	Description	UM	Type	FB BIT	Def	Min	Max	Acc	Mod
22.11.2	3172	Brake open delay	s	FLOAT		0.20	0.0	60.0	ERW	VS

Setting of the delay for mechanical opening of the brake

Menu	PAR	Description	UM	Type	FB BIT	Def	Min	Max	Acc	Mod
22.11.3	3174	Brake close delay	s	FLOAT		0.20	0.0	60.0	ERW	VS

Setting of the delay to reach the motor zero speed before closing the brake.

22.12 - FUNCTIONS/VF ENERGY SAVE

With V/f control, the Energy saving function automatically reduces the output voltage requested by the configured V/f curve, making it possible to save energy without changing the speed of the motor.

The output voltage can be reduced for as long as it is possible to reduce the flux current without increasing the torque current. If the output voltage is reduced too much the drive will be unable to maintain a constant motor speed.

If the Energy saving function is enabled, the output voltage is only reduced if the drive is in the drive ready condition and the speed reference is within the following range:

25% of **Vf frequency** (par. 2408) < speed reference < **Vf frequency** (par. 2408)

When the speed ramp output is constant for a time that can be set in parameter **3324 Energysave delay** the Energy saving function automatically reduces the output voltage. The output voltage reduction phase stops and is maintained when the torque current moves out of the range configured in parameter **3326 Energysave trqband 1**.

In the low output voltage condition, if there is a change in the ramp input reference or in the load conditions bringing the torque current outside the range set in parameter **3328 Energysave trqband 2**, the Energy saving function automatically restores the output voltage.

The energy saving function attempts to reduce the output voltage to a fixed minimum limit that is 70% of the voltage defined by the V/f curve.

Note: For increased energy saving, disable the function set in parameter **2404 Voltage torque boost** or reduce the boost set in parameter **2402 Voltage boost gain** as these functions tend to maintain the flux current at a constant level rendering the Energy saving function ineffective.

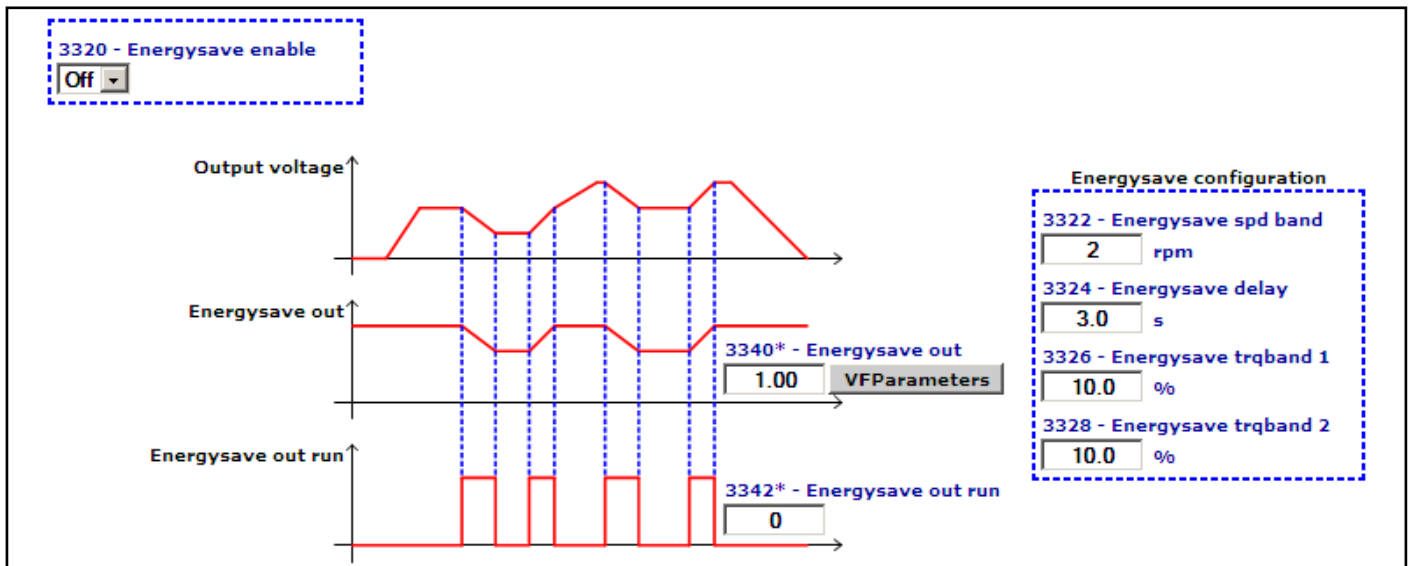

Menu	PAR	Description	UM	Type	FB BIT	Def	Min	Max	Acc	Mod
22.12.1	3320	Energysave enable		BIT		0	0	1	ERWZ	V

This parameter enables the energy saving function

0 Enabled

1 Disabled

If set to **0** the energy saving function is disabled

If set to **1** the energy saving function is enabled

Menu	PAR	Description	UM	Type	FB BIT	Def	Min	Max	Acc	Mod
22.12.2	3322	Energysave spd band	rpm	INT16		2	0	100	ERW	V

This parameter is used to set a speed used to calculate a range around the ramp output. When the ramp reference is inside this range it is constant and the ramp output has reached the steady state. The Energy saving function uses this information to decide whether or not to apply the output voltage reduction.

This parameter can be changed if there are small, continuous changes in the speed of the speed reference to avoid continuously entering/leaving the output voltage reduction condition.

Menu	PAR	Description	UM	Type	FB BIT	Def	Min	Max	Acc	Mod
22.12.3	3324	Energysave delay	s	FLOAT		3.0	0.1	120.0	ERW	V

This parameter is used to set the delay, once the speed set point has been reached, before starting to reduce the output voltage.

Menu	PAR	Description	UM	Type	FB BIT	Def	Min	Max	Acc	Mod
22.12.4	3326	Energysave trqband 1	perc	FLOAT		10.0	0.0	100.0	ERWS	V

This parameter is used to set a percentage used to calculate a range around the torque current the moment the

output voltage starts to be reduced.

The torque current value is saved the moment the voltage starts to be reduced. if the torque current is not within the calculated range during the output voltage reduction phase, output voltage reduction is aborted.

Menu	PAR	Description	UM	Type	FB BIT	Def	Min	Max	Acc	Mod
22.12.2	3328	Energysave trqband 2	perc	FLOAT		10.0	0.0	100.0	ERWS	V

This parameter is used to set a percentage used to calculate a range around the torque current the moment output voltage reduction is aborted. The torque current is saved at the end of the voltage reduction phase. if the torque current is not within the calculated range, due to a change in the load while functioning at low voltage, the output voltage requested by the V/f curve must be restored.

Menu	PAR	Description	UM	Type	FB BIT	Def	Min	Max	Acc	Mod
22.12.2	3340	Energysave out		FLOAT	16/32BIT	0.0	0.0	1.0	ER	V

This parameter is used to read the request to reduce the output voltage.

22.13 - FUNCTIONS/RTC_SET

Menu	PAR	Description	UM	Type	FB BIT	Def	Min	Max	Acc	Mod
22.13.2	3980	Rtc year		UINT16		2000	2000	2069	ERW	VS

Setting/modification of the current year

Menu	PAR	Description	UM	Type	FB BIT	Def	Min	Max	Acc	Mod
22.13.4	3982	Rtc month		UINT16		1	0	12	ERW	VS

Setting/modification of the current month

Menu	PAR	Description	UM	Type	FB BIT	Def	Min	Max	Acc	Mod
22.13.4	3984	Rtc day		UINT16		1	0	31	ERW	VS

Setting/modification of the current day

Menu	PAR	Description	UM	Type	FB BIT	Def	Min	Max	Acc	Mod
22.13.5	3986	Rtc hour		UINT16		0	0	23	ERW	VS

Setting/modification of the current hour

Menu	PAR	Description	UM	Type	FB BIT	Def	Min	Max	Acc	Mod
22.13.6	3988	Rtc minute		UINT16		0	0	59	ERW	VS

Setting/modification of the current minute

Menu	PAR	Description	UM	Type	FB BIT	Def	Min	Max	Acc	Mod
22.13.7	3990	Rtc second		UINT16		0	0	59	ERW	VS

Setting/modification of the current second

Menu	PAR	Description	UM	Type	FB BIT	Def	Min	Max	Acc	Mod
22.13.8	3992	Rtc calibration		INT16		0	-31	31	ERW	VS

This parameter is used to gauge the real-time clock counting speed, if the clock is not accurate enough.

23 – COMMUNICATION

23.1 – COMMUNICATION/RS485

The ADV200 drive is provided with a standard port (9 pole sub-D connector: XS) for connecting the RS485 serial line used for drive-PC point-to-point communication (via the WEG_eXpress configuration software) or for the multidrop connection.

The RS485 serial line format is: 8 data bits, no parity and one stop bit.

Menu	PAR	Description	UM	Type	FB BIT	Def	Min	Max	Acc	Mod
23.1.1	3800	Drive address		UINT16		1	1	255	ERW	VS

Setting of the address to which the drive responds when connected to the RS485 serial line.

Menu	PAR	Description	UM	Type	FB BIT	Def	Min	Max	Acc	Mod
23.1.2	3802	Serial baudrate		ENUM		38400	0	2	ERW	VS

Setting of the RS485 serial communication speed (Baud Rate).

0 9600
1 19200
2 38400

Menu	PAR	Description	UM	Type	FB BIT	Def	Min	Max	Acc	Mod
23.1.3	3810	Serial parameter		ENUM		None,8,1	0	3	ERW	VS

Setting of the format of the RS485 serial communication data.

0 None,8,1
1 None,8,2
2 Even,8,1
3 Odd,8,1

Menu	PAR	Description	UM	Type	FB BIT	Def	Min	Max	Acc	Mod
23.1.4	3804	Serial protocol		ENUM		Modbus	0	1	ERW	VS

Setting of the serial communication protocol:

0 Modbus
1 Jbus

Setting to **0** selects the Modbus RTU (Remote Terminal Unit) serial communication protocol.

Setting to **1** selects the Jbus serial communication protocol. The Jbus protocol is functionally identical to the Modbus, except for the different numbering of addresses: in the Modbus these start from zero (0000 = 1st address) while in the JBUS they start from one (0001 = 1st address) and maintain this difference throughout numbering.

Menu	PAR	Description	UM	Type	FB BIT	Def	Min	Max	Acc	Mod
23.1.5	3806	Serial delay	ms	UINT16		0	0	1000	ERW	VS

Setting of the minimum delay between the drive receiving the last byte and starting its response. This delay avoids conflicts on the serial line when the RS485 interface that is used has not been pre-set for automatic Tx/Rx switching. The parameter only concerns the use of the standard RS485 serial line.

Example: if the delay in Tx/Rx switching on the master is a maximum of 20ms, the Ser answer delay parameter must be set to at least 20ms: 22ms

Menu	PAR	Description	UM	Type	FB BIT	Def	Min	Max	Acc	Mod
23.1.6	3808	Serial swap data		BIT		0	0	1	ERW	VS

This parameter enables the exchange of the reading of the High and Low parts of the words for FLOAT, UINT32, INT32 type parameters when using the Modbus protocol.

23.2 – COMMUNICATION/FIELDBUS CONFIG

Menu	PAR	Description	UM	Type	FB BIT	Def	Min	Max	Acc	Mod
23.2.1	4000	Fieldbus type		ENUM		Off	0	5	RW	VS

Setting of the type of fieldbus to be used.

- 0 Off
- 1 CanOpen
- 2 DeviceNet
- 3 Profibus
- 10 DS402
- 30 Profidrive
- 40 Rte

If set to **0** no fieldbus is selected.

If set to **1** the CanOpen fieldbus profile is selected.

If set to **2** the Profibus-DP fieldbus profile is selected.

If set to **3** the DeviceNet fieldbus profile is selected.

If set to **10** the DS402 fieldbus is selected.

If set to **30** the Profidrive fieldbus is selected.

If set to **40** the Real Time Ethernet fieldbus is selected.

Menu	PAR	Description	UM	Type	FB BIT	Def	Min	Max	Acc	Mod
23.2.2	4004	Fieldbus baudrate		ENUM		500k	0	12	RW	VS

Setting of the communication network speed (Baud Rate).

- 0 Auto
- 1 125k
- 2 250k
- 3 500k
- 4 1M
- 5 9600
- 6 19200
- 7 93750
- 8 187.5k
- 9 1.5M
- 10 3M
- 11 6M
- 12 12M

Menu	PAR	Description	UM	Type	FB BIT	Def	Min	Max	Acc	Mod
23.2.3	4006	Fieldbus address		INT16		3	0	255	RW	VS

Setting of the node address of the drive when connected to the network.

Menu	PAR	Description	UM	Type	FB BIT	Def	Min	Max	Acc	Mod
23.2.4	4010	Fieldbus M->S enable		ENUM		Enable	0	1	ERWZ	VS

Setting of fieldbus data updating.

- 0 Disable
- 1 Enable

If set to **0**, the possibility of sending commands and references from the drive PLC via the fieldbus is disabled.

If set to **1** the possibility of sending commands and references from the drive PLC via the fieldbus is enabled.

Menu	PAR	Description	UM	Type	FB BIT	Def	Min	Max	Acc	Mod
23.2.5	4012	Fieldbus alarm mode		INT32		0	0	1	ERWZ	VS

Setting of the **Opt Bus Fault** alarm generation mode.

- 0 Off
- 1 On

If set to **0** the alarm is only generated if the drive is enabled.
If set to **1** the alarm is generated even with the drive disabled.

Menu	PAR	Description	UM	Type	FB BIT	Def	Min	Max	Acc	Mod
23.2.6	4014	Fieldbus state		ENUM		Stop	0	9	R	VS

The logic status of the fieldbus connection is displayed. The value depends on the type of bus that is used.

The following logic states are displayed if the CANopen or Rte fieldbus is selected:

- 0 Stop
- 1 PreOperational
- 2 Operational

The following logic states are displayed if the Profibus fieldbus is selected:

- 3 Error
- 4 WaitPRM
- 5 WaitCFG
- 6 DataExchange
- 7 DPErrors

The following logic states are displayed if the Rte fieldbus is selected:

- 8 SafeOp
- 9 Init

Menu	PAR	Description	UM	Type	FB BIT	Def	Min	Max	Acc	Mod
23.2.7	4398	RTE protocol		ENUM		None	0	107	ER	VS

The Real Time Ethernet protocol implemented on the expansion card is displayed.

- 0 None
- 1 Ethercat
- 2 EthernetIP
- 3 GdNet
- 4 Profinet
- 5 ModbusTCP
- 6 Powerlink
- 107 Profidrive

Menu	PAR	Description	UM	Type	FB BIT	Def	Min	Max	Acc	Mod
23.2.8	5608	IP address		UINT32		0	0	4294967295	ER	VS

Display of DCP address set via configuration of Profinet node.

23.3 – COMMUNICATION/FIELDBUS M->S

Configuration of input data

There are 16 groups of parameters, with the same structure, for configuring data to be exchanged cyclically with the fieldbus. Each group permits the exchange of a single datum, which corresponds to a single drive parameter.

The data written by the Master (a PLC, PC or control panel) to the Slave (the drive) can be configured in the COMMUNICATION/FIELDBUS M2S menu, hence the name of the M->S menu:

Parameter for setting input data:

It must contain a valid IPA corresponding to the parameter to be written, or 0 if sys (PAR 4022...4172 **Fieldbus M->Sn**)

sys) is **Fill** or **Mdplc**.

For *src* (Source) parameters, if you select PAR 4024 **Fieldbus M->S1 mon** in the corresponding enum, the value of parameter 4020 is automatically set to the IPA of the *src*.

E.g.: if PAR 4020 **Fieldbus M->S1 ipa** = 610 then PAR 610 **Ramp ref 1 src** = PAR 4020 **Fieldbus M->S1 ipa**.

For *src* parameters with a FB type other than 0, the datum coming to the fieldbus is not written in the enum selection but directly in the mon associated with the *src*.

E.g.: PAR 4020 **Fieldbus M->S1 ipa** = 610, the reference from the bus is sent to PAR 620 **Ramp ref 1 mon**, it does not modify the selection of PAR 610 **Ramp ref 1 src** which continues to be set to PAR 4020 **Fieldbus M->S1 ipa**.

If it contains a valid IPA and is forced to 0 the corresponding *sys* parameter assumes the value of **Fill** (16 or 32 depending on the previous setting), to guarantee that the structure of the exchanged data area is not changed.

PAR 4022 **Fieldbus M->S1 sys** Format of the datum to exchange

This parameter is automatically adjusted to the recommended value when the corresponding PAR 4020...4170 **Fieldbus M->Sn ipa** is modified. Although the automatic value is user-definable, acceptable values depend on the datum IPA parameter: some combinations are not allowed and generate a configuration alarm at restart.

Values:

- **Not assigned**: if set to “**Not assigned**” this and all subsequent groups (regardless of their *sys*) are not part of the data exchanged, regardless of the IPA.
- **Fill16/32**: the datum is exchanged on the fieldbus but not written in any parameter.
- **Eu**: the datum is exchanged in 16-bit signed integer format with the parameter unit configured in the corresponding IPA or, in the case of *src* with the corresponding mon (e.g.: if PAR 4020 **Fieldbus M->S1 ipa** = PAR 610 **Ramp ref 1 src** and PAR 4022 **Fieldbus M->S1 sys** = **Eu** the datum is in rpm), multiplied by div. This setting is only possible for some parameters. See the table of FBUS types in the list of parameters. For these parameters the datum is exchanged every ms.
- **Eu_float** : **Eu_float**: same as **Eu**, but the datum is in floating point 32-bit IEEE754 single precision format.
- **Count16/32**: the datum is exchanged in internal units (see scaling table) every ms (e.g.: if PAR 4020 **Fieldbus M->S1 ipa** = 610, PAR 610 **Ramp ref 1 src** and PAR 4022 **Fieldbus M->S1 sys** = **Count16** the datum is scaled so that a value of 0x4000 produces a reference equal to PAR 680 **Full scale speed**). This setting is only possible for some parameters. See the table of FBUS types in the list of parameters: if the field is empty **Count** cannot be set in the parameter. Some parameters permit the use of **Count16** (usually values in which there is no need to exchange the least significant 16 bits) and **Count32**, according to the following rule: if FBUS = 32bit only **Count32** can be set, if 16hi or 16lo **Count32** and **Count16** can both be set, indicating which word of the parameter is actually used. If **Count32** is used and the internal type of the parameter is **FLOAT** the datum must be exchanged in floating point IEEE754 single precision format, otherwise as an integer (signed or unsigned, again according to the internal type).
- **MdPlc16/32**: this indicates that the datum is for use by the MdPlc application, which will use the value of PAR 4024...4174 **Fieldbus M->Sn mon** accordingly. If set to **MdPlc16** the 16 bits of the low part of the mon are exchanged, if set to **MdPlc32** all 32 bits are exchanged. All this applies if PAR 4020...4170 **Fieldbus M->Sn mon** = 0, otherwise it behaves in the same way as **Count**.
- **Par16/32**: this is the default setting for all parameters with FB type empty so that data cannot be exchanged at 1 ms and the datum is updated in background. The datum format depends on the format of the parameter and the setting: with **Par16** the datum is a 16-bit integer (signed or unsigned, according to the external type of the parameter) with the same unit of measure as the selected parameter (multiplied by div); **Par16** is only available if the parameter is not actually a 32-bit one (e.g. it is not possible for **iPad** and **Compare**). With **Par32** the format is float if the external type of the parameter is float, otherwise it is integer, always with the unit of the parameter. Parameters with FB type not empty can also be exchanged as PAR, according to the same rules listed above.

If using the CANopen fieldbus, the *sys* is also used to structure the data area in 8-byte PDOs. The PDOs are created starting from the first group and it is necessary to guarantee that the data are contained in the PDO. Therefore, for example, a setting with PAR 4022 **Fieldbus M->S1 sys** = **Count32**, PAR 4032 **Fieldbus M->S2 sys** = **Count16**, PAR 4042 **Sys M->S3 Fieldbus** = **Count32** is not valid, as the datum in group 3 would straddle the first two 2 PDOs. In these cases, shorter PDOs can be generated by using the **Count** setting with IPA 0 (in the example PAR 4040 **IPA M->S3 Fieldbus** = 0, PAR 4042 **Fieldbus M->S3 sys** = **Count16**, PAR 4050 **Fieldbus M->S4 ipa** = IPA of the parameter that was previously in 3 and PAR 4052 **Fieldbus M->S4 sys** = **Count32**, thus using a first PDO with 6 bytes), or by creating unused areas in the PDO using **Fill** (the PDO has a size of 8 bytes but the last word is not used).

If the data cannot be mapped in the PDOs, a specific alarm is generated at startup, indicating the group with the problem. Note that this only applies to CANopen and DS402. For the other fieldbuses the exchange area is contiguous with a max size of 16 words (14 for DeviceNet).

PAR 4024 Fieldbus M->S1 mon Monitor of datum coming from the master

This is the value, already scaled in internal counts, of the datum arriving from the master. If, for example, a value equal to PAR 680 **Full scale speed** is sent to PAR 610 **Ramp ref 1 src** in rpm, the internal value is 0x40000000 = 1073741824. The scaling also includes the division of the div parameter.

PAR 4026 Fieldbus M->S1 div Divider to apply to the parameter

This can only be used for sys = Eu or Par. It divides the incoming datum by the value entered: this makes it possible to increase the resolution of the datum. For example, if IPA = PAR 610 **Ramp ref 1 src**, sys is automatically set to Eu. When div = 10 is entered, the Master must send the datum in rpm multiplied by 10, for example to send a reference equal to 100.5 rpm the datum exchanged on the bus is 1005: the resolution is therefore in tenths of a degree. Before entering a value, it is important to consider the maximum value of the datum exchanged, to make sure it can be contained in a 16-bit integer (in the example, the maximum possible speed is 3276.7 rpm).

Use

This group of parameters is repeated 16 times, making it possible to configure up to 16 input data, but also bearing in mind the maximum limit of 16 words in all (14 for DeviceNet). The total number of configurable data thus also depends on the format, whether 16 or 32-bit, according to the above rules for sys.

The drive only implements the parameters in the COMMUNICATION/FIELDBUS M2S menu at startup. Once set, they must therefore be saved and the drive restarted (this procedure is not necessary for values set via dynamic mapping by the master, currently only supported by CANopen and Ethercat). The data are processed in order from 1 to the first with sys = **Not assigned**: depending on the configuration, an area for exchanging data with the fieldbus is created, the size and composition of which are clearly-defined.

If the data entered are not consistent (for example if sys is set as Eu or Count for a parameter that does not support these, or set to 16-bit for a parameter that can only be 32, or if the IPA does not exist, or if the PDO is not the right size, etc.) alarm “[17] **Opt Bus fault**” is generated with a subcode indicating the type of problem and group in which it occurred (code meanings are described in the Interface page in Menu/FIELDBUS WORDS MAP/M->S in WEG_eXpress).

Menu	PAR	Description	UM	Type	FB BIT	Def	Min	Max	Acc	Mod
23.3.1	4020	Fieldbus M->S1 ipa		FBM2SIPA		0	0	20000	RW	VS
23.3.5	4030	Fieldbus M->S2 ipa		FBM2SIPA		0	0	20000	RW	VS
23.3.9	4040	Fieldbus M->S3 ipa		FBM2SIPA		0	0	20000	RW	VS
23.3.13	4050	Fieldbus M->S4 ipa		FBM2SIPA		0	0	20000	RW	VS
23.3.17	4060	Fieldbus M->S5 ipa		FBM2SIPA		0	0	20000	RW	VS
23.3.21	4070	Fieldbus M->S6 ipa		FBM2SIPA		0	0	20000	RW	VS
23.3.25	4080	Fieldbus M->S7 ipa		FBM2SIPA		0	0	20000	RW	VS
23.3.29	4090	Fieldbus M->S8 ipa		FBM2SIPA		0	0	20000	RW	VS
23.3.33	4100	Fieldbus M->S9 ipa		FBM2SIPA		0	0	20000	RW	VS
23.3.37	4110	Fieldbus M->S10 ipa		FBM2SIPA		0	0	20000	RW	VS
23.3.41	4120	Fieldbus M->S11 ipa		FBM2SIPA		0	0	20000	RW	VS
23.3.45	4130	Fieldbus M->S12 ipa		FBM2SIPA		0	0	20000	RW	VS
23.3.49	4140	Fieldbus M->S13 ipa		FBM2SIPA		0	0	20000	RW	VS
23.3.53	4150	Fieldbus M->S14 ipa		FBM2SIPA		0	0	20000	RW	VS
23.3.57	4160	Fieldbus M->S15 ipa		FBM2SIPA		0	0	20000	RW	VS
23.3.61	4170	Fieldbus M->S16 ipa		FBM2SIPA		0	0	20000	RW	VS

Setting of the parameter to associate with the bus channel. The default setting is 0, which means channel not active.

If the parameter to be connected is a **sorg** (source), the channel and parameter can also be associated by

modifying the **sorg** parameter in its menu.

When setting a parameter, the format is also automatically set in the sys parameter.

Menu	PAR	Description	UM	Type	FB BIT	Def	Min	Max	Acc	Mod
23.3.2	4022	Fieldbus M->S1 sys		ENUM		Not assigned	0	10	RW	VS
23.3.6	4032	Fieldbus M->S2 sys		ENUM		Not assigned	0	10	RW	VS
23.3.10	4042	Fieldbus M->S3 sys		ENUM		Not assigned	0	10	RW	VS
23.3.14	4052	Fieldbus M->S4 sys		ENUM		Not assigned	0	10	RW	VS
23.3.18	4062	Fieldbus M->S5 sys		ENUM		Not assigned	0	10	RW	VS
23.3.22	4072	Fieldbus M->S6 sys		ENUM		Not assigned	0	10	RW	VS
23.3.26	4082	Fieldbus M->S7 sys		ENUM		Not assigned	0	10	RW	VS
23.3.30	4092	Fieldbus M->S8 sys		ENUM		Not assigned	0	10	RW	VS
23.3.34	4102	Fieldbus M->S9 sys		ENUM		Not assigned	0	10	RW	VS
23.3.38	4112	Fieldbus M->S10 sys		ENUM		Not assigned	0	10	RW	VS
23.3.42	4122	Fieldbus M->S11 sys		ENUM		Not assigned	0	10	RW	VS
23.3.46	4132	Fieldbus M->S12 sys		ENUM		Not assigned	0	10	RW	VS
23.3.50	4142	Fieldbus M->S13 sys		ENUM		Not assigned	0	10	RW	VS
23.3.54	4152	Fieldbus M->S14 sys		ENUM		Not assigned	0	10	RW	VS
23.3.58	4162	Fieldbus M->S15 sys		ENUM		Not assigned	0	10	RW	VS
23.3.62	4172	Fieldbus M->S16 sys		ENUM		Not assigned	0	10	RW	VS

Setting of the format of the datum received on the channel. When the src parameter is programmed, the format is automatically programmed on the relative sys. If the src parameter is reset to null, the format does not change. The value of the format can be selected from the following list, according to the parameter selected as the source:

- 0 Not assigned
- 1 Count 16
- 2 Count 32
- 3 Fill 16
- 4 Fill 32
- 5 Mdplc 16
- 6 Mdplc 32
- 7 Eu
- 8 Eu float
- 9 Par 16
- 10 Par 32

If set to **0** the channel is not assigned.

If set to **1** the datum is assigned a 16-bit count.

If set to **2** the datum is assigned a 32-bit count.

If set to **3** 16 bits on the channel are reserved for the datum, not used.

If set to **4** 32 bits on the channel are reserved for the datum, not used.

If set to **5** the datum is assigned a 16-bit count used by MDPLC.

If set to **6** the datum is assigned a 32-bit count used by MDPLC.

If set to **7** the datum is assigned engineering units on a 16-bit integer.

If set to **8** the datum is assigned engineering units on a 32-bit integer.

If set to **9**, the datum is assigned a 16-bit integer engineering unit format not in real time (5-10ms)

If set to **10** the datum is assigned a 32-bit integer engineering unit format or float format if the associated parameter is a float-type parameter not in real time (5-10ms)

Note! If the sys parameter is **not assigned**, none of the subsequent fieldbus channels are read, even if programmed.

Menu	PAR	Description	UM	Type	FB BIT	Def	Min	Max	Acc	Mod
23.3.3	4024	Fieldbus M->S1 mon		INT32	32	0	0	0	ER	VS
23.3.7	4034	Fieldbus M->S2 mon		INT32	32	0	0	0	ER	VS
23.3.11	4044	Fieldbus M->S3 mon		INT32	32	0	0	0	ER	VS
23.3.15	4054	Fieldbus M->S4 mon		INT32	32	0	0	0	ER	VS
23.3.19	4064	Fieldbus M->S5 mon		INT32	32	0	0	0	ER	VS
23.3.23	4074	Fieldbus M->S6 mon		INT32	32	0	0	0	ER	VS
23.3.27	4084	Fieldbus M->S7 mon		INT32	32	0	0	0	ER	VS
23.3.31	4094	Fieldbus M->S8 mon		INT32	32	0	0	0	ER	VS
23.3.35	4104	Fieldbus M->S9 mon		INT32	32	0	0	0	ER	VS
23.3.39	4114	Fieldbus M->S10 mon		INT32	32	0	0	0	ER	VS
23.3.43	4124	Fieldbus M->S11 mon		INT32	32	0	0	0	ER	VS
23.3.47	4134	Fieldbus M->S12 mon		INT32	32	0	0	0	ER	VS
23.3.51	4144	Fieldbus M->S13 mon		INT32	32	0	0	0	ER	VS
23.3.55	4154	Fieldbus M->S14 mon		INT32	32	0	0	0	ER	VS
23.3.59	4164	Fieldbus M->S15 mon		INT32	32	0	0	0	ER	VS
23.3.63	4174	Fieldbus M->S16 mon		INT32	32	0	0	0	ER	VS

The value received from the bus is displayed. This parameter must be associated with the src parameter to enable the **M->S** channel.

The user may modify the **M->S** and by **S->M** sys parameters. The consistency of the sys with the parameter assigned to the channel is checked.

A Fieldbus M->S X Mon parameter can only be assigned to a single "src". If assigned to more than one src, an error signal is generated during fieldbus initialization.

Menu	PAR	Description	UM	Type	FB BIT	Def	Min	Max	Acc	Mod
23.3.4	4026	Fieldbus M->S1 div		FLOAT		1.0	1.0	1000.0	ERW	VS
23.3.8	4036	Fieldbus M->S2 div		FLOAT		1.0	1.0	1000.0	ERW	VS
23.3.12	4046	Fieldbus M->S3 div		FLOAT		1.0	1.0	1000.0	ERW	VS
23.3.16	4056	Fieldbus M->S4 div		FLOAT		1.0	1.0	1000.0	ERW	VS
23.3.20	4066	Fieldbus M->S5 div		FLOAT		1.0	1.0	1000.0	ERW	VS
23.3.24	4076	Fieldbus M->S6 div		FLOAT		1.0	1.0	1000.0	ERW	VS
23.3.28	4086	Fieldbus M->S7 div		FLOAT		1.0	1.0	1000.0	ERW	VS
23.3.32	4096	Fieldbus M->S8 div		FLOAT		1.0	1.0	1000.0	ERW	VS
23.3.36	4106	Fieldbus M->S9 div		FLOAT		1.0	1.0	1000.0	ERW	VS
23.3.40	4116	Fieldbus M->S10 div		FLOAT		1.0	1.0	1000.0	ERW	VS
23.3.44	4126	Fieldbus M->S11 div		FLOAT		1.0	1.0	1000.0	ERW	VS
23.3.48	4136	Fieldbus M->S12 div		FLOAT		1.0	1.0	1000.0	ERW	VS
23.3.52	4146	Fieldbus M->S13 div		FLOAT		1.0	1.0	1000.0	ERW	VS
23.3.56	4154	Fieldbus M->S14 div		FLOAT		1.0	1.0	1000.0	ERW	VS
23.3.60	4166	Fieldbus M->S15 div		FLOAT		1.0	1.0	1000.0	ERW	VS
23.3.64	4176	Fieldbus M->S16 div		FLOAT		1.0	1.0	1000.0	ERW	VS

The **Div M->Sx fieldbus** parameters can be used to increase the resolution of the datum sent on the bus to the drive in the corresponding channel in EU and EU_float exchange mode. The parameter value is used by the drive as the divider of the incoming datum, so that a number with decimal digits can be transferred.

N.B.: You must check the size in bits of the datum that is sent to make sure that the maximum value in bits fits in a 16-bit integer. For example, if specifying the divider as “Fieldbus M->Sn div” = 1000, the maximum value that can be used for the exchanged datum is 32.768 (32768/1000).

Example: **Div M->Sx fieldbus = 10, M->S1 fieldbus par = Ramp ref src 1, Sys M->S1 fieldbus = Eu.** If the PLC sends the decimal value 1000 on the first word the value of **ramp ref 1** on the drive is $1000/10 = 100$.

23.4 – COMMUNICATION/FIELDBUS S->M

Configuration of output data

The data read by the Master (a PLC, PC or control panel) sent by the slave (the drive) can be configured in the COMMUNICATION/FIELDBUS S2M menu.

Since the functions of the 16 groups are similar to those of the COMMUNICATION/FIELDBUS Ms2S menu, only the differences are listed here:

PAR 4180 **Fieldbus S->M1 ipa**: unlike with M->S, the src are not managed. The IPA therefore always refers to the parameter that is entered (e.g. to monitor ramp 1 input I must select PAR 620 **Ramp ref 1 mon** whereas if I select PAR 610 **Ramp ref 1 src** I would read the selection of the enum of that src).

Moreover, with sys = MdPlc16/32, you cannot enter IPA 0 but must enter the IPA of the corresponding dig, for the first group PAR 4184 **Dig Fieldbus S->M1**, etc.), the MdPlc application then writes a value in this parameter, which is sent to the bus in 16 or 32-bit format according to the sys.

If you enter 0 when the IPA was set to a value other than zero, the sys is automatically set to Fill16 or 32, to guarantee the structure of the data exchange area.

PAR 4182 **Fieldbus S->M1 sys** : the only difference regards the MdPlc16/32 setting, as explained above, to send all 32 bits or just the low word of the corresponding dig.

PAR 4186 **Fieldbus S->M1 mul**: this works symmetrically with respect to M>S. In this case a multiplier is applied to increase the resolution of the output datum (for Eu and Par only). For example, if PAR 4180 **Fieldbus S->M1 ipa** = PAR 260 **Motor speed**, PAR 4182 **Fieldbus S->M1 sys** = Eu, PAR 4186 **Fieldbus S->M1 mul** = 10 the datum sent to the bus is in rpm multiplied by 10: if the drive turns at 100.5 rpm the master receives a value equal to 1005.

PAR 4184 **Dig Fieldbus S->M1**: there are no monitors for output data, the digs send a fixed datum to the bus (with the sys set to Count32) or for the MdPlc application, which writes a value in these parameters (with sys set to Md-Plc16/32).

The groups are processed in order at startup as for M>S. If there are any configuration errors, alarm “[17] **Opt Bus fault**” is generated with a subcode indicating the type of problem and the group in which it occurred (see the S->M page in WEG_eXpress for the meaning of the code).

Menu	PAR	Description	UM	Type	FB BIT	Def	Min	Max	Acc	Mod
23.4.1	4180	Fieldbus S->M1 ipa		FBM2SIPA		0	0	20000	RW	VS
23.4.5	4190	Fieldbus S->M2 ipa		FBM2SIPA		0	0	20000	RW	VS
23.4.9	4200	Fieldbus S->M3 ipa		FBM2SIPA		0	0	20000	RW	VS
23.4.13	4210	Fieldbus S->M4 ipa		FBM2SIPA		0	0	20000	RW	VS
23.4.17	4220	Fieldbus S->M5 ipa		FBM2SIPA		0	0	20000	RW	VS
23.4.21	4230	Fieldbus S->M6 ipa		FBM2SIPA		0	0	20000	RW	VS
23.4.25	4240	Fieldbus S->M7 ipa		FBM2SIPA		0	0	20000	RW	VS
23.4.29	4250	Fieldbus S->M8 ipa		FBM2SIPA		0	0	20000	RW	VS
23.4.33	4260	Fieldbus S->M9 ipa		FBM2SIPA		0	0	20000	RW	VS
23.4.37	4270	Fieldbus S->M10 ipa		FBM2SIPA		0	0	20000	RW	VS
23.4.41	4280	Fieldbus S->M11 ipa		FBM2SIPA		0	0	20000	RW	VS

23.4.45	4290	Fieldbus S->M12 ipa	FBM2SIPA	0	0	20000	RW	VS
23.4.49	4300	Fieldbus S->M13 ipa	FBM2SIPA	0	0	20000	RW	VS
23.4.53	4310	Fieldbus S->M14 ipa	FBM2SIPA	0	0	20000	RW	VS
23.4.57	4320	Fieldbus S->M15 ipa	FBM2SIPA	0	0	20000	RW	VS
23.4.61	4330	Fieldbus S->M16 ipa	FBM2SIPA	0	0	20000	RW	VS

Setting of the parameter to associate with the bus channel. The default setting is 0, which means channel not active.

When setting a parameter, the format is also automatically set in the sys parameter

Menu	PAR	Description	UM	Type	FB BIT	Def	Min	Max	Acc	Mod
23.4.2	4182	Fieldbus S->M1 sys		ENUM		Not assigned	0	10	RW	VS
23.4.6	4192	Fieldbus S->M2 sys		ENUM		Not assigned	0	10	RW	VS
23.4.10	4202	Fieldbus S->M3 sys		ENUM		Not assigned	0	10	RW	VS
23.4.14	4212	Fieldbus S->M4 sys		ENUM		Not assigned	0	10	RW	VS
23.4.18	4222	Fieldbus S->M5 sys		ENUM		Not assigned	0	10	RW	VS
23.4.22	4232	Fieldbus S->M6 sys		ENUM		Not assigned	0	10	RW	VS
23.4.26	4242	Fieldbus S->M7 sys		ENUM		Not assigned	0	10	RW	VS
23.4.30	4252	Fieldbus S->M8 sys		ENUM		Not assigned	0	10	RW	VS
23.4.34	4262	Fieldbus S->M9 sys		ENUM		Not assigned	0	10	RW	VS
23.4.38	4272	Fieldbus S->M10 sys		ENUM		Not assigned	0	10	RW	VS
23.4.42	4282	Fieldbus S->M11 sys		ENUM		Not assigned	0	10	RW	VS
23.4.46	4292	Fieldbus S->M12 sys		ENUM		Not assigned	0	10	RW	VS
23.4.50	4302	Fieldbus S->M13 sys		ENUM		Not assigned	0	10	RW	VS
23.4.54	4312	Fieldbus S->M14 sys		ENUM		Not assigned	0	10	RW	VS
23.4.58	4322	Fieldbus S->M15 sys		ENUM		Not assigned	0	10	RW	VS
23.4.62	4332	Fieldbus S->M16 sys		ENUM		Not assigned	0	10	RW	VS

When setting the sorg parameter the format is automatically set on the relative **sys**. If **sorg** is set to **null**, the data format does not change. The value of the format can be selected from the following list, according to the parameter selected as the source:

- 0 Not assigned
- 1 Count 16
- 2 Count 32
- 3 Fill 16
- 4 Fill 32
- 5 Mdplc 16
- 6 Mdplc 32
- 7 Eu
- 8 Eu float
- 9 Par 16
- 10 Par 32

If set to **0** the channel is not assigned.

If set to **1** the datum is assigned a 16-bit count.

If set to **2** the datum is assigned a 32-bit count.

If set to **3** 16 bits on the channel are reserved for the datum, not used.

If set to **4** 32 bits on the channel are reserved for the datum, not used.

If set to **5** the datum is assigned a 16-bit count used by MDPLC.

If set to **6** the datum is assigned a 32-bit count used by MDPLC.

If set to **7** the datum is assigned engineering units on a 16-bit integer.

If set to **8** the datum is assigned engineering units on a 32-bit integer.

If set to **9**, the datum is assigned a 16-bit integer engineering unit format not in real time (5-10ms)

If set to **10** the datum is assigned a 32-bit integer engineering unit format or float format if the associated parameter is a float-type parameter not in real time (5-10ms)

Note ! If the sys parameter is **not assigned**, none of the subsequent channels are transferred to the fieldbus, even if programmed.

Menu	PAR	Description	UM	Type	FB BIT	Def	Min	Max	Acc	Mod
23.4.3	4184	Dig Fieldbus S->M1		INT32	32	0	0	0	ERW	VS
23.4.7	4194	Dig Fieldbus S->M2		INT32	32	0	0	0	ERW	VS
23.4.11	4204	Dig Fieldbus S->M3		INT32	32	0	0	0	ERW	VS
23.4.15	4214	Dig Fieldbus S->M4		INT32	32	0	0	0	ERW	VS
23.4.19	4224	Dig Fieldbus S->M5		INT32	32	0	0	0	ERW	VS
23.4.23	4234	Dig Fieldbus S->M6		INT32	32	0	0	0	ERW	VS
23.4.27	4244	Dig Fieldbus S->M7		INT32	32	0	0	0	ERW	VS
23.4.31	4254	Dig Fieldbus S->M8		INT32	32	0	0	0	ERW	VS
23.4.35	4264	Dig Fieldbus S->M9		INT32	32	0	0	0	ERW	VS
23.4.39	4274	Dig Fieldbus S->M10		INT32	32	0	0	0	ERW	VS
23.4.43	4284	Dig Fieldbus S->M11		INT32	32	0	0	0	ERW	VS
23.4.47	4294	Dig Fieldbus S->M12		INT32	32	0	0	0	ERW	VS
23.4.51	4304	Dig Fieldbus S->M13		INT32	32	0	0	0	ERW	VS
23.4.55	4314	Dig Fieldbus S->M14		INT32	32	0	0	0	ERW	VS
23.4.59	4324	Dig Fieldbus S->M15		INT32	32	0	0	0	ERW	VS
23.4.63	4334	Dig Fieldbus S->M16		INT32	32	0	0	0	ERW	VS

If associated with the relative src, the value of this parameter is sent to the bus.

The user may modify the M->S and by S->M sys parameters. The consistency of the sys with the parameter assigned to the channel is checked.

Menu	PAR	Description	UM	Type	FB BIT	Def	Min	Max	Acc	Mod
23.4.4	4186	Fieldbus S->M1 mul		FLOAT		1.0	1.0	1000.0	ERW	VS
23.4.8	4196	Fieldbus S->M2 mul		FLOAT		1.0	1.0	1000.0	ERW	VS
23.4.12	4206	Fieldbus S->M3 mul		FLOAT		1.0	1.0	1000.0	ERW	VS
23.4.16	4216	Fieldbus S->M4 mul		FLOAT		1.0	1.0	1000.0	ERW	VS
23.4.20	4226	Fieldbus S->M5 mul		FLOAT		1.0	1.0	1000.0	ERW	VS
23.4.24	4236	Fieldbus S->M6 mul		FLOAT		1.0	1.0	1000.0	ERW	VS
23.4.28	4246	Fieldbus S->M7 mul		FLOAT		1.0	1.0	1000.0	ERW	VS
23.4.32	4256	Fieldbus S->M8 mul		FLOAT		1.0	1.0	1000.0	ERW	VS
23.4.36	4266	Fieldbus S->M9 mul		FLOAT		1.0	1.0	1000.0	ERW	VS
23.4.40	4276	Fieldbus S->M10 mul		FLOAT		1.0	1.0	1000.0	ERW	VS
23.4.44	4286	Fieldbus S->M11 mul		FLOAT		1.0	1.0	1000.0	ERW	VS
23.4.48	4296	Fieldbus S->M12 mul		FLOAT		1.0	1.0	1000.0	ERW	VS
23.4.52	4306	Fieldbus S->M13 mul		FLOAT		1.0	1.0	1000.0	ERW	VS
23.4.56	4316	Fieldbus S->M14 mul		FLOAT		1.0	1.0	1000.0	ERW	VS
23.4.60	4326	Fieldbus S->M15 mul		FLOAT		1.0	1.0	1000.0	ERW	VS
23.4.64	4336	Fieldbus S->M16 mul		FLOAT		1.0	1.0	1000.0	ERW	VS

The "Fieldbus S->Mx mul" parameters are multipliers that the drive applies to the datum before sending it to the bus. It is therefore possible to increase the resolution of some values read in EU and EU_float mode, also using decimal digits.

N.B.: The drive does not check that the multiplied parameter expressed in bits fits in a 16-bit integer. You must make sure that the multiplier is compatible with the maximum value of the exchanged parameter and that it does not exceed the maximum size of 32768.

Example: **Fieldbus S->Mx mul = 10, S->M1 fieldbus par = Motor speed, Sys S->M1 fieldbus = Eu.**
 If the motor is running at 100 rpm, the PLC reads the value $100 * 10 = 1000$ on the first word that is exchanged.

23.5 – COMMUNICATION/WORD COMP

Menu	PAR	Description	UM	Type	FB BIT	Def	Min	Max	Acc	Mod
23.5.1	4400	Word bit0 src		LINK	16	6000	0	16384	ERW	VS
23.5.2	4402	Word bit1 src		LINK	16	6000	0	16384	ERW	VS
23.5.3	4404	Word bit2 src		LINK	16	6000	0	16384	ERW	VS
23.5.4	4406	Word bit3 src		LINK	16	6000	0	16384	ERW	VS
23.5.5	4408	Word bit4 src		LINK	16	6000	0	16384	ERW	VS
23.5.6	4410	Word bit5 src		LINK	16	6000	0	16384	ERW	VS
23.5.7	4412	Word bit6 src		LINK	16	6000	0	16384	ERW	VS
23.5.8	4414	Word bit7 src		LINK	16	6000	0	16384	ERW	VS
23.5.9	4416	Word bit8 src		LINK	16	6000	0	16384	ERW	VS
23.5.10	4418	Word bit9 src		LINK	16	6000	0	16384	ERW	VS
23.5.11	4420	Word bit10 src		LINK	16	6000	0	16384	ERW	VS
23.5.12	4422	Word bit11 src		LINK	16	6000	0	16384	ERW	VS
23.5.13	4424	Word bit12 src		LINK	16	6000	0	16384	ERW	VS
23.5.14	4426	Word bit13 src		LINK	16	6000	0	16384	ERW	VS
23.5.15	4428	Word bit14 src		LINK	16	6000	0	16384	ERW	VS
23.5.16	4430	Word bit15 src		LINK	16	6000	0	16384	ERW	VS

Selection of the origin (source) of the signal to be used for coding in **Word comp**. This function allows the user to compose a single word composed of 16 signals, each of which can be selected from among those listed in the “**L_DIGSEL1**” selection list.

The values of the sectioned sizes are converted into a single word.

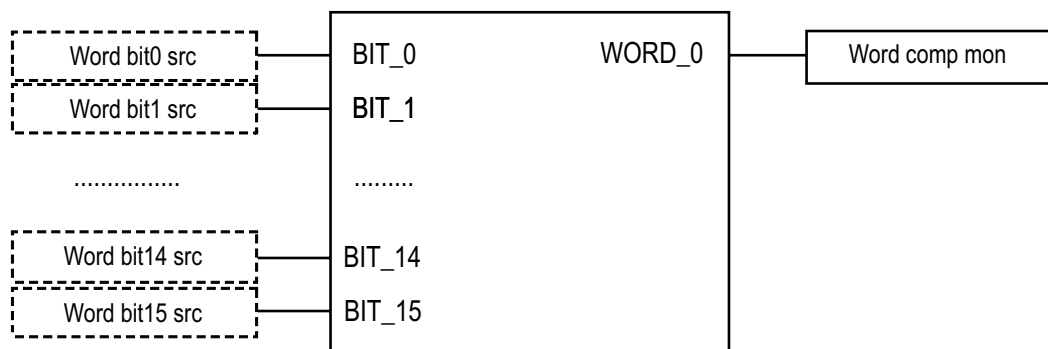

Menu	PAR	Description	UM	Type	FB BIT	Def	Min	Max	Acc	Mod
23.5.17	4432	Word comp mon		UIN32	16	0	0	0	ER	VS

The hexadecimal value of the Word comp output is displayed.

23.6 – COMMUNICATION/WORD DECOMP

Menu	PAR	Description	UM	Type	FB BIT	Def	Min	Max	Acc	Mod
23.6.1	4450	Dig word decomp		UINT32	16	0	0	0	ERW	VS

Setting of the digital input decoded by the “**Word decomp**” block.

Menu	PAR	Description	UM	Type	FB BIT	Def	Min	Max	Acc	Mod
23.6.2	4452	Word decomp src		LINK	16	4450	0	16384	ERW	VS

Selection of the origin (source) of the word to be decoded by the “**Word decomp**” block. Each bit that is part of the word to be decoded is associated with the output channel of the “**Word decomp**” block. The variables that can be used for this function can be selected from among those listed in the “**L_WDECOMP**” selection list.

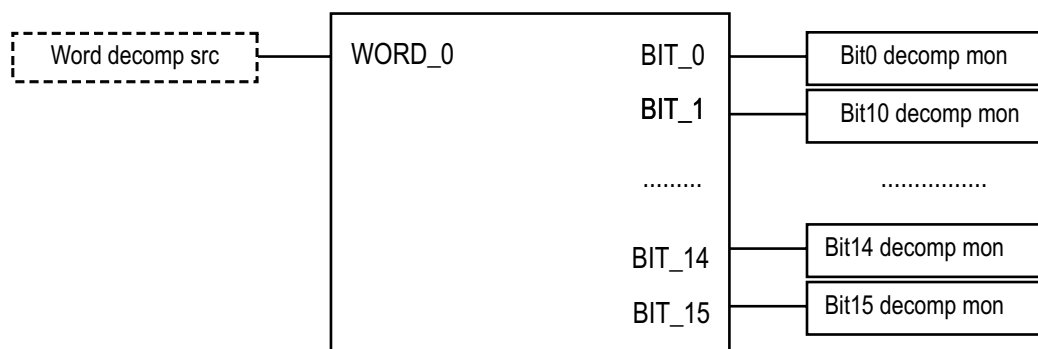

Menu	PAR	Description	UM	Type	FB BIT	Def	Min	Max	Acc	Mod
23.6.3	4454	Bit0 decomp mon		BIT	16	0	0	1	ER	VS
23.6.4	4456	Bit1 decomp mon		BIT	16	0	0	1	ER	VS
23.6.5	4458	Bit2 decomp mon		BIT	16	0	0	1	ER	VS
23.6.6	4460	Bit3 decomp mon		BIT	16	0	0	1	ER	VS
23.6.7	4462	Bit4 decomp mon		BIT	16	0	0	1	ER	VS
23.6.8	4464	Bit5 decomp mon		BIT	16	0	0	1	ER	VS
23.6.9	4466	Bit6 decomp mon		BIT	16	0	0	1	ER	VS
23.6.10	4468	Bit7 decomp mon		BIT	16	0	0	1	ER	VS
23.6.11	4470	Bit8 decomp mon		BIT	16	0	0	1	ER	VS
23.6.12	4472	Bit9 decomp mon		BIT	16	0	0	1	ER	VS
23.6.13	4474	Bit10 decomp mon		BIT	16	0	0	1	ER	VS
23.6.14	4476	Bit11 decomp mon		BIT	16	0	0	1	ER	VS
23.6.15	4478	Bit12 decomp mon		BIT	16	0	0	1	ER	VS
23.6.16	4480	Bit13 decomp mon		BIT	16	0	0	1	ER	VS
23.6.17	4482	Bit14 decomp mon		BIT	16	0	0	1	ER	VS
23.6.18	4484	Bit15 decomp mon		BIT	16	0	0	1	ER	VS

The single bits that make up the selected word are displayed.

24 – ALARM CONFIG

In the **ALARM CONFIG** menu the type of effect any alarm signals have on the drive is determined:

- The alarm status is saved
- How must the drive react to the alarm signal?
- Auto restart
- Alarm reset

For some alarms, behaviour can be configured separately for each signal, while for the others the **Disable drive** is executed. Individual signals can also be sent to a programmable digital output.

Activity	Ignore	The alarm is not included in the list of alarms, it is not included in the alarm log, it is not signalled on the digital outputs, no drive commands are modified.
	Warning	The alarm is included in the list of alarms, it is included in the alarm log, it is signalled on the digital outputs, the First alarm information is updated, the Alarm enabled information is updated, no drive commands are modified.
	Disable drive	The alarm is included in the list of alarms, it is included in the alarm log, it is signalled on the digital outputs, the First alarm information is updated, the Alarm enabled information is updated, a command is sent to stop and disable the motor, which stops due to inertia.
	Stop	The alarm is included in the list of alarms, it is included in the alarm log, it is signalled on the digital outputs, the First alarm information is updated, the Alarm enabled information is updated, a Stop command is sent. When the zero speed is reached the drive is disabled. If Ramp control mode is enabled, the drive moves to the zero speed with the set ramp time; when the Speed delay 0 signal is activated the drive is disabled. If Speed control mode is enabled, the drive moves to the zero speed with the maximum current possible; when the Speed delay 0 signal is activated the drive is disabled. If Torque control mode is enabled, the drive moves to the zero speed with the time set by the load; when the Speed delay 0 signal is activated the drive is disabled.
	Fast stop	The alarm is included in the list of alarms, it is included in the alarm log, it is signalled on the digital outputs, the First alarm information is updated, the Alarm enabled information is updated, a Fast Stop command is sent. When the zero speed is reached the drive is disabled. If Ramp control mode is enabled, the drive moves to the zero speed with the set fast stop ramp time (deceleration time 3); when the Speed delay 0 signal is activated the drive is disabled. If Speed control mode is enabled, the drive moves to the zero speed with the maximum current possible; when the Speed delay 0 signal is activated the drive is disabled. If Torque control mode is enabled, the drive moves to the zero speed with the set load time; when the Speed delay 0 signal is activated the drive is disabled.

n alarms with Activity = Ignore or Warning can be enabled at the same time.

If an alarm with Activity = Stop or Fast Stop is enabled and another alarm with an Activity other than Ignore or Warning is enabled, the drive stops and is disabled.

Not all alarms allow the controlled stopping of the drive. The following table shows the possibility of setting the Activities for the individual alarm signals.

Alarm	Ignore	Warning	Disable drive	Stop	Fast stop
ExtFlt	✓	✓	✓	✓	✓
Motor OT	✓	✓	✓	✓	✓
Overspeed	✓	✓	✓	✓	✓
SpdRefLoss	✓	✓	✓	✓	✓
SpdFbkLoss	✓	✓	✓	✓	✓
Drive ovld	✓	✓	✓	✓	✓
Motor ovld	✓	✓	✓	✓	✓
Bres ovld	✓	✓	✓	✓	✓
HTsens	-	-	✓	-	-
InAir	✓	✓	✓	✓	✓
Desat	-	-	✓	-	-
IOverC	-	-	✓	-	-
OverV	-	-	✓	-	-
UnderV	-	-	✓	-	-
PhLoss	✓	✓	✓	✓	✓
Bus option	✓	✓	✓	✓	✓
GroundFault thr	-	-	✓	-	-
Broken belt	✓	✓	✓	✓	✓
End curve	✓	✓	✓	✓	✓
Dry pump	✓	✓	✓	✓	✓
No flow	✓	✓	✓	✓	✓
Clean alarm	✓	✓	✓	✓	✓
Analog 1 Err	✓	✓	✓	✓	✓
Analog 2 Err	✓	✓	✓	✓	✓
Analog 1x Err	✓	✓	✓	✓	✓
Analog 2x Err	✓	✓	✓	✓	✓

Menu	PAR	Description	UM	Type	FB BIT	Def	Min	Max	Acc	Mod
24.1	4500	Fault reset src		LINK	16	1120	0	16384	RW	VS

Selection of the origin (source) of the signal to be used for the command to reset the drive after an alarm. The terminal that can be used for this function can be selected from among those listed in the “L_DIGSEL2” selection list.

Menu	PAR	Description	UM	Type	FB BIT	Def	Min	Max	Acc	Mod
24.2	4502	ExtFlt src		LINK	16	6000	0	16384	RW	VS

Selection of the origin (source) of the signal to be used as the input for the drive external fault alarm **ExtFlt**. The terminal that can be used for this function can be selected from among those listed in the “L_DIGSEL2” selection list.

Menu	PAR	Description	UM	Type	FB BIT	Def	Min	Max	Acc	Mod
24.3	4504	ExtFlt activity		ENUM		Disable	0	4	RW	VS

Setting of the behaviour of the drive in the event of an external fault alarm **ExtFlt**. This alarm indicates the intervention of a drive external protection.

- 0 Ignore
- 1 Warning
- 2 Disable
- 3 Stop
- 4 Fast stop

Menu	PAR	Description	UM	Type	FB BIT	Def	Min	Max	Acc	Mod
24.4	4506	ExtFlt restart		ENUM		Disable	0	1	RW	VS
		Enabling of automatic restart after the external fault alarm ExtFlt								
		0 Disable								
		1 Enable								
Menu	PAR	Description	UM	Type	FB BIT	Def	Min	Max	Acc	Mod
24.5	4508	ExtFlt restart time	ms	UINT16		1000	120	30000	RW	VS
		Setting of the time within which the External Fault alarm must be reset in order to perform automatic restart.								
Menu	PAR	Description	UM	Type	FB BIT	Def	Min	Max	Acc	Mod
24.6	4510	ExtFlt holdoff	ms	UINT16		0	0	10000	RW	VS
		Setting of the delay between the signalling of the external fault alarm ExtFlt and enabling of the alarm. If an alarm condition occurs, the drive will wait for the set time before blocking is enabled. If the alarm is removed within the set time, the drive will not indicate any alarm condition.								
Menu	PAR	Description	UM	Type	FB BIT	Def	Min	Max	Acc	Mod
24.7	4520	MotorOT src		LINK	16	6000	0	16384	RW	VS
		Selection of the origin (source) of the signal to be used for the motor overtemperature alarm MotorOT . The terminal that can be used for this function can be selected from among those listed in the " L_DIGSEL2 " selection list.								
Menu	PAR	Description	UM	Type	FB BIT	Def	Min	Max	Acc	Mod
24.8	4522	MotorOT activity		ENUM		Warning	0	4	RW	VS
		Setting of the behaviour of the drive in case of a motor overtemperature alarm MotorOT . This alarm indicates that the motor temperature is too high.								
		0 Ignore								
		1 Warning								
		2 Disable								
		3 Stop								
		4 Fast stop								
Menu	PAR	Description	UM	Type	FB BIT	Def	Min	Max	Acc	Mod
24.9	4524	MotorOT restart		ENUM		Disable	0	1	RW	VS
		Enabling of automatic restart after the motor overtemperature alarm MotorOT .								
		0 Disable								
		1 Enable								
Menu	PAR	Description	UM	Type	FB BIT	Def	Min	Max	Acc	Mod
24.10	4526	TMotorOT restart time	ms	UINT16		1000	120	30000	RW	VS
		Setting of the time within which the Motor Overtemperature alarm must be reset in order to perform automatic restart.								
Menu	PAR	Description	UM	Type	FB BIT	Def	Min	Max	Acc	Mod
24.11	4528	MotorOT holdoff	ms	UINT16		1000	0	30000	RW	VS
		Setting of the delay between the signalling of the motor overtemperature alarm MotorOT and enabling of the alarm. If an alarm condition occurs, the drive will wait for the set time before enabling the alarm. If the alarm is removed within the set time, the drive will not indicate any alarm condition.								
Menu	PAR	Description	UM	Type	FB BIT	Def	Min	Max	Acc	Mod
24.12	4530	Motor OT probe		ENUM		SRC	0	4	RW	VS
		Selection of the motor temperature sensor. Motor overtemperature can be controlled by the PT100, KTY and								

PTC probes in addition to the clickson.

These temperature probes must be connected to the new EXP-IO-SENS-1000-ADV and EXP-IO-SENS-100-ADV. expansion cards.

The overtemperature alarm is triggered when the temperature reading exceeds a set limit. When selecting a type of probe, set the count limit with a default value of 150°C for the PT100 and KTY84 or 4000 ohm for the PTC.

- 0 SRC
- 1 PT100 AN1X
- 2 PT100 AN2X
- 3 KTY84
- 4 PTC

Select **0** to select as the origin (source) of the digital signal used to detect the motor overtemperature that defined by parameter **24.7 (IPA 4520) MotorOT src**.

Set to **1** to use temperature sensor PT100 connected to analog input 1 of the EXP-IO-SENS-100-ADV card.

Set to **2** to use temperature sensor PT100 connected to analog input 2 of the EXP-IO-SENS-100-ADV card.

Set to **3** to use temperature sensor KTY84 connected between +10V and the Temp input of the EXP-IO-SENS-100-ADV card.

Set to **4** to use temperature sensor PTC connected between +10V and the Temp input of the EXP-IO-SENS-100-ADV card.

Menu	PAR	Description	UM	Type	FB BIT	Def	Min	Max	Acc	Mod
24.13	4532	MotorOT thr	cnt	UINT16		0	0	32767	RW	VS

Setting of the motor temperature sensor threshold before the alarm is triggered. . Values to be set for an OT at 150°C are:

- PT100: 13650
- KTY84: 13850
- PTC: 21280 equal to 4000 ohm

Menu	PAR	Description	UM	Type	FB BIT	Def	Min	Max	Acc	Mod
24.14	4536	MotorOT mon	cnt	UINT16		0	0	32767	RW	VS

The motor temperature sensor threshold (in count values) before the alarm is triggered is displayed.

Menu	PAR	Description	UM	Type	FB BIT	Def	Min	Max	Acc	Mod
24.15	4540	Overspeed threshold	rpm	INT32		CALCI	0	CALCI	RW	VS

Setting of the threshold above which the overspeed alarm **Overspeed** is enabled.

Menu	PAR	Description	UM	Type	FB BIT	Def	Min	Max	Acc	Mod
24.16	4542	Overspeed activity		ENUM		Disable	0	4	RW	VS

Setting of the behaviour of the drive in case of a motor overspeed alarm **Overspeed**. This alarm indicates that the motor speed has exceeded the threshold set in the **Speed ref top lim** and **Speed ref bottom lim** parameters in the COMMANDS menu.

- 0 Ignore
- 1 Warning
- 2 Disable
- 3 Stop
- 4 Fast stop

Menu	PAR	Description	UM	Type	FB BIT	Def	Min	Max	Acc	Mod
24.17	4544	Overspeed holdoff	ms	UINT16		0	0	5000	RW	VS

Setting of the delay between the signalling of the motor overspeed alarm **Overspeed** and enabling of the alarm. If an alarm condition occurs, the drive will wait for the set time before enabling the alarm. If the alarm is removed within the set time, the drive will not indicate any alarm condition.

Menu	PAR	Description	UM	Type	FB BIT	Def	Min	Max	Acc	Mod
24.18	4550	SpdRefLoss threshold	rpm	INT16		100	0	CALCI	RW	VS

Setting of the threshold below which the speed reference loss alarm **SpdRefLoss** occurs.

Menu	PAR	Description	UM	Type	FB BIT	Def	Min	Max	Acc	Mod
24.19	4552	SpdRefLoss activity		ENUM		Ignore	0	4	RW	VS

Setting of the behaviour of the drive in case of a speed reference loss alarm **SpdRefLoss**. This alarm indicates that the difference between the speed regulator reference and the actual motor speed is more than 100 rpm.

This alarm must be disabled (= 0 Ignore) when parameter 556 **Control mode select** is set to Torque (0) or when parameter 2354 is set to a value other than zero.

- 0 Ignore
- 1 Warning
- 2 Disable
- 3 Stop
- 4 Fast stop

Menu	PAR	Description	UM	Type	FB BIT	Def	Min	Max	Acc	Mod
24.20	4554	SpdRefLoss holdoff	ms	UINT16		1000	0	10000	RW	FV_

Setting of the delay between the signalling of the speed reference loss alarm condition SpdRefLoss and enabling of the alarm. If an alarm condition occurs, the drive will wait for the set time before enabling the alarm. If the alarm is removed within the set time, the drive will not indicate any alarm condition.

Menu	PAR	Description	UM	Type	FB BIT	Def	Min	Max	Acc	Mod
24.21	4570	Drive ovld activity		ENUM		Ignore	0	4	ERW	VS

Setting of the behaviour of the drive in case of a drive overload alarm **Drive ovld**. This alarm indicates that the drive overload threshold has been reached.

- 0 Ignore
- 1 Warning
- 2 Disable
- 3 Stop
- 4 Fast stop

Menu	PAR	Description	UM	Type	FB BIT	Def	Min	Max	Acc	Mod
24.22	4572	Motor ovld activity		ENUM		Warning	0	4	ERW	VS

Setting of the behaviour of the drive in case of a motor overload alarm **Motor ovld [14]**. This alarm indicates that the motor overload threshold has been reached.

- 0 Ignore
- 1 Warning
- 2 Disable
- 3 Stop
- 4 Fast stop

Menu	PAR	Description	UM	Type	FB BIT	Def	Min	Max	Acc	Mod
24.23	4574	Bres ovld activity		ENUM		Disable	0	4	ERW	VS

Setting of the behaviour of the drive in case of a braking resistor overload alarm **Bres ovld**. This alarm indicates that the braking resistor overload threshold has been reached.

- 0 Ignore
- 1 Warning
- 2 Disable
- 3 Stop
- 4 Fast stop

Menu	PAR	Description	UM	Type	FB BIT	Def	Min	Max	Acc	Mod
24.24	4582	HTsens restart		ENUM		Disable	0	1	ERW	VS
Enabling of automatic restart after the drive heatsink overtemperature alarm Heatsinks OTUT [10] .										
<ul style="list-style-type: none"> 0 Disable 1 Enable 										

Menu	PAR	Description	UM	Type	FB BIT	Def	Min	Max	Acc	Mod
24.25	4584	HTsens restart time	ms	UINT16		20000	120	60000	ERW	VS
Setting of the time within which the Heatsinks OTUT [10] alarm must be reset in order to perform automatic restart.										

Menu	PAR	Description	UM	Type	FB BIT	Def	Min	Max	Acc	Mod
24.26	4600	InAir activity		ENUM		Stop	0	4	ERW	VS
Setting of the behaviour of the drive in case of an intake air overtemperature alarm Intakeair OT [11] . This alarm indicates that the temperature of the intake cooling air is too high.										
<ul style="list-style-type: none"> 0 Ignore 1 Warning 2 Disable 3 Stop 4 Fast stop 										

Menu	PAR	Description	UM	Type	FB BIT	Def	Min	Max	Acc	Mod
24.27	4602	InAir restart		ENUM		Disable	0	1	ERW	VS
Enabling of automatic restart after the intake air overtemperature alarm Intakeair OT [11] .										
<ul style="list-style-type: none"> 0 Disable 1 Enable 										

Menu	PAR	Description	UM	Type	FB BIT	Def	Min	Max	Acc	Mod
24.28	4604	InAir restart time	ms	UINT16		1000	120	30000	ERW	VS
Setting of the time within which the Intakeair OT [11] alarm must be reset in order to perform automatic restart.										

Menu	PAR	Description	UM	Type	FB BIT	Def	Min	Max	Acc	Mod
24.29	4606	InAir holdoff	ms	UINT16		10000	0	30000	ERW	VS
Setting of the delay between the signalling of the intake air overtemperature alarm Intakeair OT [11] and enabling of the alarm. If an alarm condition occurs, the drive will wait for the set time before enabling the alarm. If the alarm is removed within the set time, the drive will not indicate any alarm condition.										

Menu	PAR	Description	UM	Type	FB BIT	Def	Min	Max	Acc	Mod
24.30	4610	Desat restart		ENUM		Disable	0	1	ERW	VS
Enabling of automatic restart after the desaturation alarm Desat . This alarm indicates a short circuit between the motor phases or on the power bridge.										
<ul style="list-style-type: none"> 0 Disable 1 Enable 										

Menu	PAR	Description	UM	Type	FB BIT	Def	Min	Max	Acc	Mod
24.31	4612	Desat restart time	ms	U	INT16	2000	1000	10000	ERW	VS

Setting of the time within which the **Desaturation** alarm must be reset in order to perform automatic restart. (Time with alarm signal active + 1000 msec).

Menu	PAR	Description	UM	Type	FB BIT	Def	Min	Max	Acc	Mod
24.32	4620	IOverC restart		E	ENUM	Disable	0	1	ERW	VS

Enabling of automatic restart after the drive overcurrent alarm. This alarm indicates an overcurrent (or short circuit between phases or towards the ground).

0 Disable
1 Enable

Menu	PAR	Description	UM	Type	FB BIT	Def	Min	Max	Acc	Mod
24.33	4622	IOverC restart time	ms	U	INT16	2000	1000	10000	ERW	VS

Setting of the time within which the **Overcurrent** alarm must be reset in order to perform automatic restart. (Time with alarm signal active + 1000 msec).

Menu	PAR	Description	UM	Type	FB BIT	Def	Min	Max	Acc	Mod
24.34	4630	OverV restart		E	ENUM	Disable	0	1	ERW	VS

Enabling of automatic restart after the overvoltage alarm. This alarm indicates an overvoltage on the intermediate circuit (DC link)

0 Disable
1 Enable

Menu	PAR	Description	UM	Type	FB BIT	Def	Min	Max	Acc	Mod
24.35	4632	OverV restart time	ms	U	INT16	2000	1000	10000	ERW	VS

Setting of the time within which the **Overvoltage** alarm must be reset in order to perform automatic restart. (Time with alarm signal active + 1000 msec).

Menu	PAR	Description	UM	Type	FB BIT	Def	Min	Max	Acc	Mod
24.36	4640	UnderV restart		E	ENUM	Enable	0	1	ERW	VS

Enabling of automatic restart after the undervoltage alarm. This alarm indicates an undervoltage on the intermediate circuit (DC link)

0 Disable
1 Enable

Menu	PAR	Description	UM	Type	FB BIT	Def	Min	Max	Acc	Mod
24.37	4642	UnderV restart time	ms	U	INT16	1000	120	10000	ERW	VS

Setting of the time within which the **Undervoltage** alarm must be reset in order to perform automatic restart. (Time with alarm signal active + 100 msec).

Menu	PAR	Description	UM	Type	FB BIT	Def	Min	Max	Acc	Mod
24.38	4650	UVRep attempts		U	INT16	5	0	1000	ERW	VS

Setting of the maximum number of attempts at automatic restart after the **Undervoltage** alarm before a **Mult Undervoltage** alarm is generated. If this parameter is set to 1000 an infinite number of attempts are available.

Menu	PAR	Description	UM	Type	FB BIT	Def	Min	Max	Acc	Mod
24.39	4652	UVRep delay	s	U	INT16	240	0	300	ERW	VS

Setting of the time within which, if no automatic restarts are executed after the **Undervoltage** alarm, the attempts counter is reset. In this way the number of attempts set in **UVRep attempt** are still available.

Menu	PAR	Description	UM	Type	FB BIT	Def	Min	Max	Acc	Mod
24.40	4660	PhLoss activity		ENUM		Disable	0	4	ERW	VS
Setting of the behaviour of the drive in case of a no phase alarm. This alarm indicates the absence of a drive power supply phase.										
<ul style="list-style-type: none"> 0 Ignore 1 Warning 2 Disable 3 Stop 4 Fast stop 										

Menu	PAR	Description	UM	Type	FB BIT	Def	Min	Max	Acc	Mod
24.41	4662	PhLoss restart		ENUM		Disable	0	1	ERW	VS
Enabling of automatic restart after the no phase alarm.										
<ul style="list-style-type: none"> 0 Disable 1 Enable 										

Menu	PAR	Description	UM	Type	FB BIT	Def	Min	Max	Acc	Mod
24.42	4664	PhLoss restart time	ms	UINT16		1000	120	10000	ERW	VS
Setting of the time within which the Phase loss alarm must be reset in order to perform automatic restart. (Time with alarm signal active + 100 msec).										

Menu	PAR	Description	UM	Type	FB BIT	Def	Min	Max	Acc	Mod
24.43	4670	Optionbus activity		ENUM		Disable	0	4	ERW	VS
Setting of the behaviour of the drive in case of an Opt Bus Fault alarm.										
<ul style="list-style-type: none"> 0 Ignore 1 Warning 2 Disable 3 Stop 4 Fast stop 										

Menu	PAR	Description	UM	Type	FB BIT	Def	Min	Max	Acc	Mod
24.44	4672	Optbus fault en src		LINK	16BIT	6002	0	16384	ERW	VS
Selection of the origin (source) of the signal to be used as " Opt bus fault " [17] alarm. The terminal that can be used for this function can be selected from among those listed in the " L_DIGSEL1 " selection list.										
The default is PAR 6002 One . If it is selected the PAR 1030 Local / remote mon , it can inhibit the alarm only when you switch from " Remote " to " Local ".										

Menu	PAR	Description	UM	Type	FB BIT	Def	Min	Max	Acc	Mod
24.45	4680	Ground Fault thr	perc	FLOAT		10.0	0	150.0	ERWS	VS
Setting of the threshold for the ground short circuit alarm Ground Fault .										

Menu	PAR	Description	UM	Type	FB BIT	Def	Min	Max	Acc	Mod
24.46	4700	Alarm dig sel 1		ENUM		No alarm	0	40	ERW	VS
24.47	4702	Alarm dig sel 2		ENUM		No alarm	0	40	ERW	VS
24.48	4704	Alarm dig sel 3		ENUM		No alarm	0	40	ERW	VS
24.49	4706	Alarm dig sel 4		ENUM		No alarm	0	40	ERW	VS
Setting of the alarm signal to enable on a digital output. The digital output is selected using parameters Alm dig out mon 1÷4 , which can be enabled in the L_DIGSEL1 selection list.										
<ul style="list-style-type: none"> 0 No alarm 1 Overvoltage 										

- 2 Undervoltage
- 3 Ground fault
- 4 Overcurrent
- 5 Desaturation
- 6 MultiUndervolt
- 7 MultiOvercurr
- 8 MultiDesat
- 9 Heatsink OT
- 10 HeatsinkS OTUT
- 11 Intakeair OT
- 12 Motor OT
- 13 Drive overload
- 14 Motor overload
- 15 Bres overload
- 16 Phase loss
- 17 Opt Bus fault
- 18 Opt 1 IO fault
- 19 Opt 2 IO fault
- 20 Not Used1
- 21 External fault
- 22 Not Used2
- 23 Overspeed
- 24 Speed ref loss
- 25 Emg stop alarm
- 26 Power down
- 27 Broken belt
- 28 End curve
- 29 Dry pump
- 30 No flow
- 31 Clean alarm
- 32 Not Used6
- 33 Min Speed
- 34 Plc2 fault
- 35 Plc3 fault
- 36 Plc4 fault
- 37 Plc5 fault
- 38 Plc6 fault
- 39 Plc7 fault
- 40 Plc8 fault

Menu	PAR	Description	UM	Type	FB BIT	Def	Min	Max	Acc	Mod
24.50	4720	Alm autoreset time	s	FLOAT		0	0	60.0	ERW	VS

Setting of the time interval that must pass before executing an automatic reset.

If no alarms are enabled the drive is set to restart.

If some alarms are still enabled the drive is set to execute a new attempt at automatic reset.

At each attempted reset a counter increases. If the limit set in the Alm autoreset number parameter is reached the drive is set to make no more attempts at reset and waits for a user reset.

The counter is set to zero when an automatic reset or user reset is performed and no alarms are enabled.

If the parameter is 0 the function is disabled.

Menu	PAR	Description	UM	Type	FB BIT	Def	Min	Max	Acc	Mod
24.51	4722	Alm autoreset number		UINT16		20	0	100	ERW	VS

Setting of the maximum number of attempted automatic resets.

Menu	PAR	Description	UM	Type	FB BIT	Def	Min	Max	Acc	Mod
24.52	7700	Broken belt activity		ENUM		Warning	0	4	RW	VS

Setting of the behaviour of the drive if the **Broken belt** alarm is present. The belt broken condition occurs if the torque required of the motor falls below a set threshold value.

- 0 Ignore
- 1 Warning
- 2 Disable
- 3 Stop
- 4 Fast stop

Menu	PAR	Description	UM	Type	FB BIT	Def	Min	Max	Acc	Mod
24.53	7702	Broken belt torque	perc	FLOAT		0.0	0.0	100.0	RW	VS

Setting of the percentage by which the torque must fall below the rated value for the alarm to be activated.

Menu	PAR	Description	UM	Type	FB BIT	Def	Min	Max	Acc	Mod
24.54	7704	Broken belt delay	s	UINT16		30	1	3600	RW	VS

Setting of the delay after which the **Broken belt** alarm is activated. If the conditions causing this alarm return to normal before the end of the set time, the alarm is not activated.

Menu	PAR	Description	UM	Type	FB BIT	Def	Min	Max	Acc	Mod
24.55	7706	Broken belt spd thr	rpm	INT16		100	0	CALCI	RW	VS

Setting of the threshold value below which the alarm is not activated.

Menu	PAR	Description	UM	Type	FB BIT	Def	Min	Max	Acc	Mod
24.56	7710	End curve activity		ENUM		Warning	0	4	RW	VS

Setting of the behaviour of the drive if the **End curve** alarm is present. If the feedback measured (e.g. pressure) stays below the reference value, with a programmable tolerance, for a programmable time and with the pump at maximum speed, an end of curve alarm is generated. This may indicate a leak in the system.

- 0 Ignore
- 1 Warning
- 2 Disable
- 3 Stop
- 4 Fast stop

Menu	PAR	Description	UM	Type	FB BIT	Def	Min	Max	Acc	Mod
24.57	7712	End curve ref thr	perc	INT16		0	0	100	RW	VS

Setting of the speed threshold (as a percentage of **Full scale speed** (PAR 680, menu 5 REFERENCES) which, if maintained with a feedback signal that is lower than the set value, the **End curve** alarm is generated.

Menu	PAR	Description	UM	Type	FB BIT	Def	Min	Max	Acc	Mod
24.58	7714	End curve delay	s	UINT16		30	1	3600	RW	VS

Setting of the delay after which, if conditions remain unchanged, the **End curve** alarm is activated.

Menu	PAR	Description	UM	Type	FB BIT	Def	Min	Max	Acc	Mod
24.59	7720	Dry pump activity		ENUM		Warning	0	4	RW	VS

Setting of the behaviour of the drive if the **Dry pump** alarm is present. The **Dry pump** alarm is activated with the **No flow** alarm if the power delivered is below the threshold calculated for the minimum power curve.

- 0 Ignore
- 1 Warning
- 2 Disable
- 3 Stop
- 4 Fast stop

Menu	PAR	Description	UM	Type	FB BIT	Def	Min	Max	Acc	Mod
24.60	7722	Dry pump delay	s	UINT16		30	1	3600	RW	VS
Setting of the delay after which, if conditions remain unchanged, the Dry pump alarm is activated.										
24.61	7726	No flow activity		ENUM		Warning	0	4	RW	VS
Setting of the behaviour of the drive if the Dry pump alarm is present. The No flow alarm is activated if the power delivered is below the threshold calculated for the minimum power curve.										
<ul style="list-style-type: none"> 0 Ignore 1 Warning 2 Disable 3 Stop 4 Fast stop 										
24.62	7728	No flow delay	s	UINT16		30	1	3600	RW	VS
Setting of the delay after which, if conditions remain unchanged, the No flow alarm is activated.										
24.63	7808	Clean alm num cycles		UINT16		1	1	100	RW	VS
Setting of the number of consecutive cleaning cycles performed close together that generate the alarm.										
24.64	7810	Clean alm thr time	rpm	INT16		0	0	8760	RW	VS
Setting of the Clean alarm time. If the time between two cleaning cycles is shorter than this time, the alarm counter is increased. The alarm is activated when the counter reaches the limit set in parameter 7808 Clean alm num cycles . The counter is reset even if the interval is only longer than this time once.										
24.65	7812	Clean activity		ENUM		Warning	0	4	RW	VS
Setting of the behaviour of the drive in case of an alarm indicating too many cleaning cycles.										
<ul style="list-style-type: none"> 0 Ignore 1 Warning 2 Disable 3 Stop 4 Fast stop 										
24.66	7816	Analog 1 err act		ENUM		Ignore	0	4	RW	VS
Setting of the behaviour of the drive if the measurement error alarm is present on analog channel 1. If an analog measurement is out of the allowed range an Analog x err alarm is generated. This control is only possible for 4-20 mA, PT100, PT1000, NI1000 probes. For temperature probes both short-circuits and power loss on the cable are detected.										
For the 4-20 mA only power loss on the cable is detected.										
<ul style="list-style-type: none"> 0 Ignore 1 Warning 2 Disable 3 Stop 4 Fast stop 										
24.67	7818	Analog 1 err delay	s	FLOAT		1	0.1	60	RW	VS
Setting of the delay after which the alarm is activated.										

Menu	PAR	Description	UM	Type	FB BIT	Def	Min	Max	Acc	Mod
24.68	7820	Analog 2 err act		ENUM		Ignore	0	4	RW	VS

Setting of the behaviour of the drive if the measurement error alarm is present on analog channel 2. If an analog measurement is out of the allowed range an **Analog x err** alarm is generated. This control is only possible for 4-20 mA, PT100, PT1000, NI1000 probes. For temperature probes both short-circuits and power loss on the cable are detected.

For the 4-20 mA only power loss on the cable is detected.

- 0 Ignore
- 1 Warning
- 2 Disable
- 3 Stop
- 4 Fast stop

Menu	PAR	Description	UM	Type	FB BIT	Def	Min	Max	Acc	Mod
24.69	7822	Analog 2 err delay	s	FLOAT		1	0.1	60	RW	VS

Setting of the delay after which the alarm is activated.

Menu	PAR	Description	UM	Type	FB BIT	Def	Min	Max	Acc	Mod
24.70	7824	Analog 1x err act	s	ENUM		Ignore	0	4	RW	VS

Setting of the behaviour of the drive if the measurement error alarm is present on analog channel 1 of the expansion card. If an analog measurement is out of the allowed range an **Analog x err** alarm is generated. This control is only possible for 4-20 mA, PT100, PT1000, NI1000 probes. For temperature probes both short-circuits and power loss on the cable are detected.

For the 4-20 mA only power loss on the cable is detected.

- 0 Ignore
- 1 Warning
- 2 Disable
- 3 Stop
- 4 Fast stop

Menu	PAR	Description	UM	Type	FB BIT	Def	Min	Max	Acc	Mod
24.71	7826	Analog 1x err delay	s	UINT16		1	0.1	60	RW	VS

Setting of the delay after which the alarm is activated.

Menu	PAR	Description	UM	Type	FB BIT	Def	Min	Max	Acc	Mod
24.72	7828	Analog 2x err act		ENUM		Ignore	0	4	RW	VS

Setting of the behaviour of the drive if the measurement error alarm is present on analog channel 2 of the expansion card. If an analog measurement is out of the allowed range an **Analog x err** alarm is generated. This control is only possible for 4-20 mA, PT100, PT1000, NI1000 probes. For temperature probes both short-circuits and power loss on the cable are detected.

For the 4-20 mA only power loss on the cable is detected.

- 0 Ignore
- 1 Warning
- 2 Disable
- 3 Stop
- 4 Fast stop

Menu	PAR	Description	UM	Type	FB BIT	Def	Min	Max	Acc	Mod
24.73	7830	Analog 2x err delay	s	UINT16		1	0.1	60	RW	VS

Setting of the delay after which the alarm is activated.

25 – ALARM LOG

This is the menu in which the log of previous alarms is saved, with the date and time of the alarm occurred. The alarms are displayed starting from the most recent (No. 1) up to the furthest back in time (No. 30). Up to 30 alarm signals can be displayed. The sub-code is used by service technicians to identify the specific type of alarm. Press the ▲ and ▼ keys to scroll the screen pages of the alarm log. The alarm log cannot be deleted.

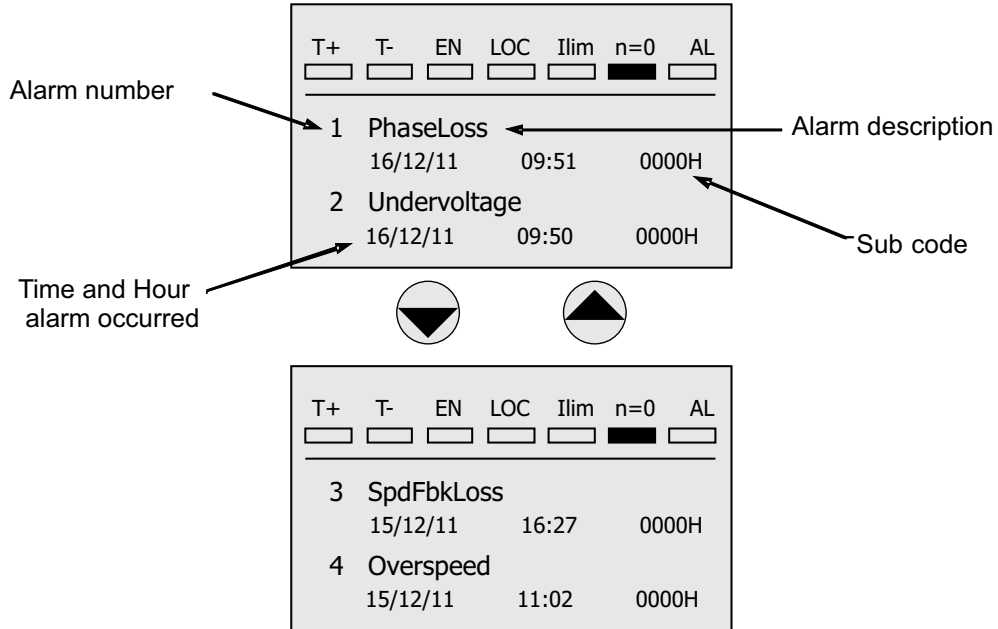

26 - PROCESS

26.1 - PROCESS/PID 1 REFERENCES

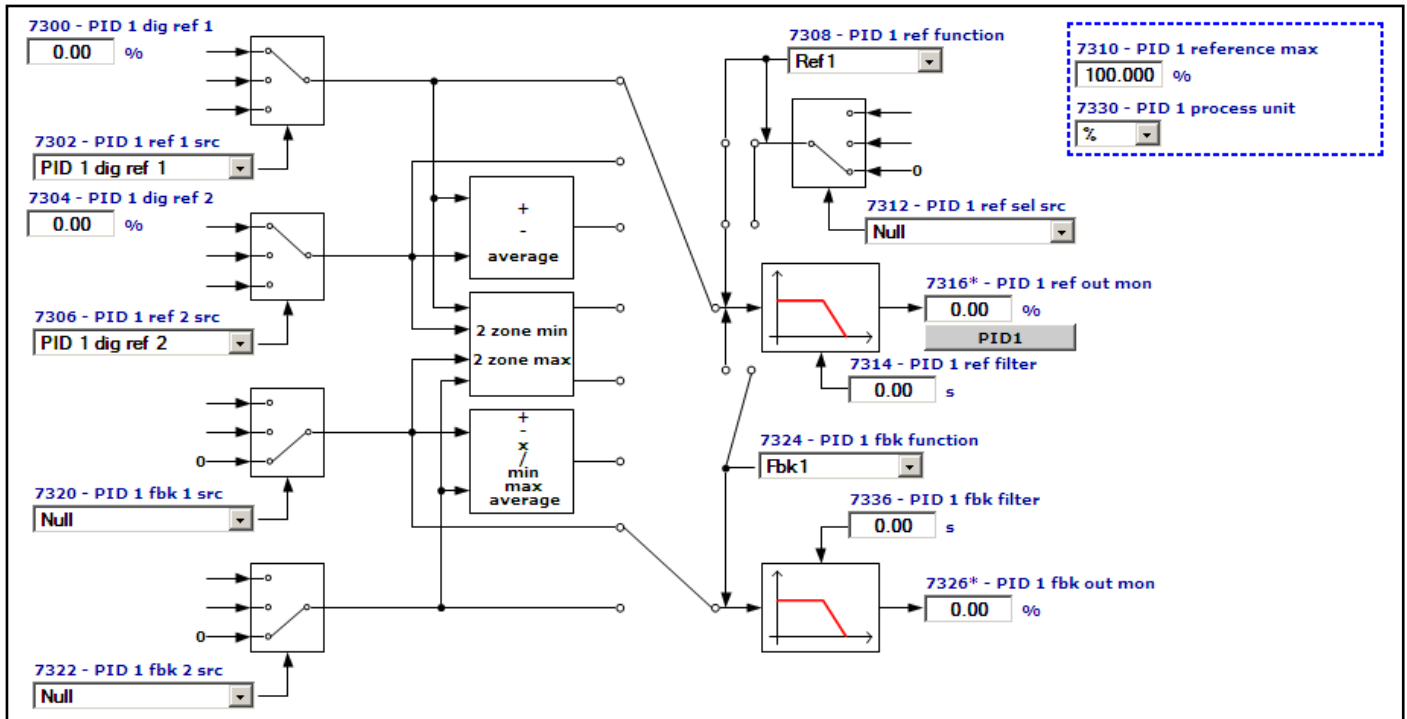

Menu	PAR	Description	UM	Typo	FB BIT	Def	Min	Max	Acc	Mod
26.1.1	7300	PID 1 dig ref 1	PID1U	FLOAT		0.0	CALCF	CALCF	RW	VS

Setting of digital reference 1 for PID 1. This reference defines the setpoint for PID controller functioning.

Menu	PAR	Description	UM	Typo	FB BIT	Def	Min	Max	Acc	Mod
26.1.2	7302	PID 1 ref 1 src		LINK	16/32BIT	7300	0	16384	RW	VS

Selection of the origin (source) of reference signal 1 for the PID 1 setpoint. The PID controller reference values can be selected from those listed in the "L_PIDREF" selection list.

Menu	PAR	Description	UM	Typo	FB BIT	Def	Min	Max	Acc	Mod
26.1.3	7304	PID 1 dig ref 2	PID1U	FLOAT		0.0	CALCF	CALCF	RW	VS

Setting of digital reference 2 for PID 1. This reference defines the setpoint for PID controller functioning.

Menu	PAR	Description	UM	Typo	FB BIT	Def	Min	Max	Acc	Mod
26.1.4	7306	PID 1 ref 2 src		LINK	16/32BIT	7304	0	16384	RW	VS

Selection of the origin (source) of reference signal 2 for the PID 1 setpoint. The PID reference values can be selected from those listed in the "L_PIDREF" selection list.

Menu	PAR	Description	UM	Typo	FB BIT	Def	Min	Max	Acc	Mod
26.1.5	7308	PID 1 ref function		ENUM		Ref1	0	5	RW	VS

This parameter is used to adjust reference 1 and 2 analog input signals for the PID1 controller:

- 0 Ref1
- 1 Ref2
- 2 Src selection
- 3 Ref1+Ref2
- 4 Ref1-Ref2
- 5 Aver ref1 ref2

Set to **0** to select the value of reference signal 1 as the setpoint for the PID 1 function.

Set to **1** to select the value of reference signal 1 as the setpoint for the PID 2 function.

Set to **2** to select the value of the reference signal 1 or reference signal 2 for the PID 1 function, depending on that selected in parameter **7312 PID 1 ref sel src** .

Set to **3** to select the result of the following formula as the setpoint for the PID 1 function:

$$rif1 \text{ value} + (rif2 \text{ value} - 50\% \text{ Full scale})$$

Set to **4** to select the result of the following formula as the setpoint for the PID 1 function:

$$(rif1 \text{ value} + 50\% \text{ of Full scale}) - rif2 \text{ value}$$

Set to **5** to select the arithmetic mean of reference 1 and reference 2 as the setpoint for the PID 1 function.

Menu	PAR	Description	UM	Typo	FB BIT	Def	Min	Max	Acc	Mod
26.1.6	7310	PID 1 reference max		FLOAT		100.0	0.0	999999.0	RW	VS

Setting of the full scale value of the reference in the selected unit of measure.

Important note: when using temperature sensors connected to the EXP-IO_SENS-....-ADV card, this parameter must be set to 180 if values are expressed in °C and 356 if expressed in °F.

Menu	PAR	Description	UM	Typo	FB BIT	Def	Min	Max	Acc	Mod
26.1.7	7312	PID 1 ref sel src		LINK	16BIT	6000	0	16384	RW	VS

Selection of the origin (source) of the PID 1 function reference signal between reference 1 and reference 2.

This setting only applies if parameter **7308 PID 1 ref functionis** set to 3 (Src selection). PID controller reference signals can be selected from those listed in the "**L_PIDREF**" selection list.

Menu	PAR	Description	UM	Typo	FB BIT	Def	Min	Max	Acc	Mod
26.1.8	7314	PID 1 ref filter	s	FLOAT		0.0	0.0	10.0	RW	VS

Setting of the value of the filter applied to the reference signal.

Menu	PAR	Description	UM	Typo	FB BIT	Def	Min	Max	Acc	Mod
26.1.9	7316	PID 1 ref out mon	PID1U	FLOAT		0.0	0.0	0.0	R	VS

The current value of the selected reference is displayed.

Menu	PAR	Description	UM	Typo	FB BIT	Def	Min	Max	Acc	Mod
26.1.10	7320	PID 1 fbk 1 src		LINK	16/32BIT	6000	0	16384	RW	VS

Selection of the origin (source) of feedback signal 1 for the PID 1 function. The PID controller feedback signals can be selected from those listed in the "**L_PIDFBK**" selection list.

Menu	PAR	Description	UM	Typo	FB BIT	Def	Min	Max	Acc	Mod
26.1.11	7322	PID 1 fbk 2 src		LINK	16/32BIT	6000	0	16384	RW	VS

Selection of the origin (source) of feedback signal 2 for the PID 1 function. The PID controller feedback signals can be selected from those listed in the "**L_PIDFBK**" selection list.

Menu	PAR	Description	UM	Typo	FB BIT	Def	Min	Max	Acc	Mod
26.1.12	7324	PID 1 fbk function		ENUM		Fbk1	0	10	RW	VS

Selection of the operation to be executed on feedback signals 1 and 2 for the PID 1 controller:

- 0** Fbk1
- 1** Fbk2
- 2** Fbk1+Fbk2

- 3 Fbk1-Fbk2
- 4 Fbk1*Fbk2
- 5 Fbk1/Fbk2
- 6 Min fbk1fbk2
- 7 Max fbk1fbk2
- 8 Aver fbk1 fbk2
- 9 2 Zone min
- 10 2 Zone max

Set to **0** to select the value of feedback signal 1 as the feedback for the PID 1 function.

Set to **1** to select the value of feedback signal 2 as the feedback for the PID 1 function.

Set to **2** to select the result of the following formula as the feedback for the PID 1 function:
fbk1 value+(fbk2 value-50% Full scale)

Set to **3** to select the result of the following formula as the feedback for the PID 1 function:
(fbk1 value+50% Full scale)-fbk2 value)

Set to **4** to select the result of the following formula as the feedback for the PID 1 function:
(fbk1 value(fbk2 value/50% Full scale)*

Set to **5** to select the result of the following formula as the feedback for the PID 1 function:
*(fbk1 value*50% Full scale) / fbk2 value)*

Set to **6** to select the lower value between feedback 1 and feedback 2 as the feedback for the PID 1 function.

Set to **7** to select the higher value between feedback 1 and feedback 2 as the feedback for the PID 1 function.

Set to **8** to select the arithmetic mean of feedback 1 and feedback 2 as the feedback for the PID 1 function.

Set to **9** to calculate the differences between ref1-fbk1 and ref2-fbk2 and use the values equal to the smaller difference for the PID 1 function.

Set to **10** to calculate the differences between ref1-fbk1 and ref2-fbk2 and use the values equal to the greater difference for the PID 1 function.

Menu	PAR	Description	UM	Typo	FB BIT	Def	Min	Max	Acc	Mod
26.1.13	7336	PID 1 fbk filter	s	FLOAT		0.0	0.0	10.0	RW	VS

Setting of the value of the filter applied to the feedback signal.

Menu	PAR	Description	UM	Typo	FB BIT	Def	Min	Max	Acc	Mod
26.1.14	7326	PID 1 fbk out mon	PID1U	FLOAT		0.0	0.0	0.0	R	VS

The current value of the selected feedback is displayed.

Menu	PAR	Description	UM	Typo	FB BIT	Def	Min	Max	Acc	Mod
26.1.15	7330	PID 1 process unit		ENUM		%	0	39	RW	VS

Use this parameter to select the unit of measure used in the process.

- 0
- 1 %
- 2 rpm
- 3 ppm
- 4 imp/s

- 5 l/s
- 6 l/m
- 7 l/h
- 8 kg/s
- 9 kg/m
- 10 kg/h
- 11 m³/s
- 12 m³/m
- 13 m³/h
- 14 m/s
- 15 mbar
- 16 bar
- 17 Pa
- 18 kPa
- 19 m
- 20 m ca
- 21 kW
- 22 °C
- 23 °F
- 24 GPM
- 25 gal/s
- 26 gal/m
- 27 gal/h
- 28 lb/s
- 29 lb/m
- 30 lb/h
- 31 CFM
- 32 ft³/s
- 33 ft³/m
- 34 ft³/h
- 35 ft/s
- 36 in wg
- 37 ft wg
- 38 PSI
- 39 Lb/i²

26.2 – PROCESS/ PID 1

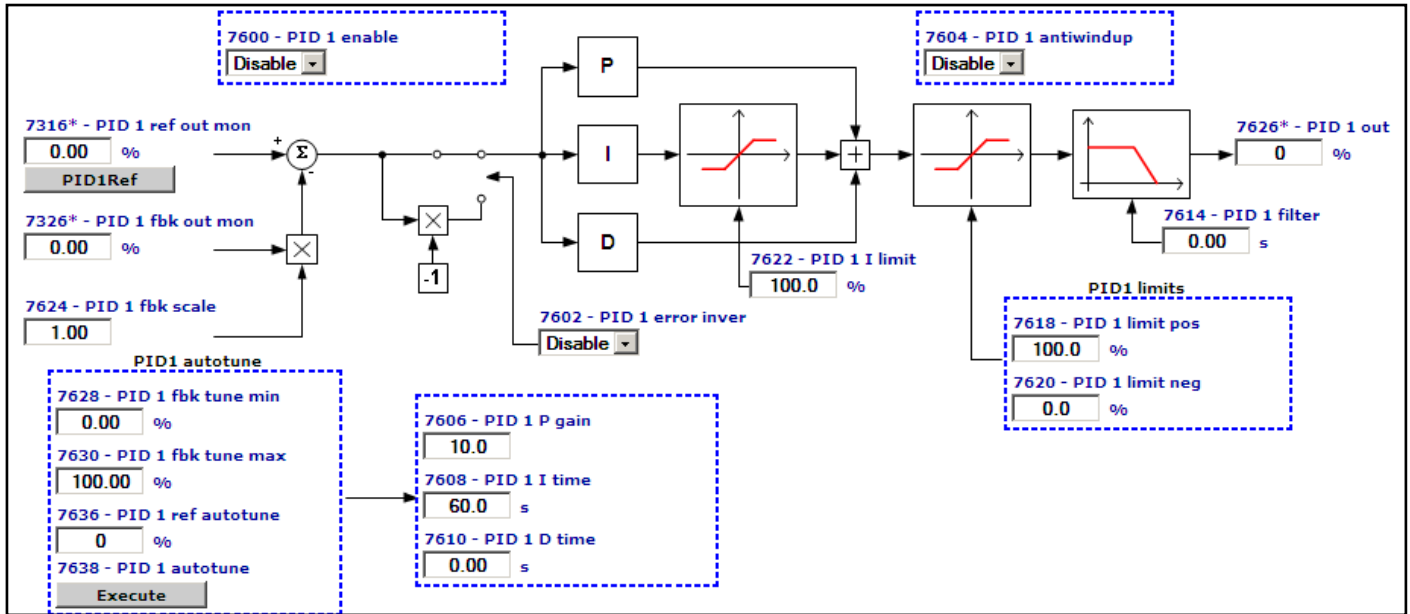

Menu	PAR	Description	UM	Typo	FB BIT	Def	Min	Max	Acc	Mod
26.2.1	7600	PID 1 enable		ENUM		Disable	0	1	RWZ	VS

Enabling of the PID 1 controller.

- 0 Disable
- 1 Enable

Set to 0 to disable the PID 1 function.

Set to 1 to enable the PID 1 function.

Menu	PAR	Description	UM	Typo	FB BIT	Def	Min	Max	Acc	Mod
26.2.2	7602	PID 1 error inver		ENUM		Disable	0	1	RWZ	VS

Use this parameter to invert the error calculated by PID 1.

- 0 Disable
- 1 Enable

If set to 0 the error calculated by the PID is not inverted.

If set to 1 the error calculated by the PID is inverted.

Menu	PAR	Description	UM	Typo	FB BIT	Def	Min	Max	Acc	Mod
26.2.3	7604	PID 1 antiwindup	PID1U	ENUM		Disable	0	1	RWZ	VS

Use this parameter to enable the PID anti-saturation (wind-up) function.

- 0 Disable
- 1 Enable

If set to 0 the value of the integrator continues to change even when the output has reached one of the limits (minimum or maximum motor speed), delaying any changes in the inverter output.

If set to 1 the integrator value is blocked if the output of the PID 1 controller has reached one of the limits (minimum or maximum motor speed) and is unable to add further changes to the value of the process parameter being controlled. In this condition the drive reacts more quickly once the PID 1 controller output returns to within the limits.

Menu	PAR	Description	UM	Typo	FB BIT	Def	Min	Max	Acc	Mod
26.2.4	7606	PID 1 P gain		FLOAT	16/32BIT	10.0	0.0	100.0	RW	VS

Setting of the integral gain of the PID 1 controller.

Menu	PAR	Description	UM	Typo	FB BIT	Def	Min	Max	Acc	Mod
26.2.5	7608	PID 1 I time	s	FLOAT		60.0	0.0	3600.0	RW	VS
Setting of the integral time of the PID 1 controller.										
26.2.6	7610	PID 1 D time	s	FLOAT		0.0	0.0	1.0	RW	VS
Setting of the derivative time of the PID 1 controller.										
26.2.7	7614	PID 1 filter	s	FLOAT		0.0	0.0	10.0	RW	VS
Setting of the time constant used for the PID 1 output filter.										
26.2.8	7618	PID 1 limit pos	perc	FLOAT		100.0	0.0	200.0	RW	VS
Setting of the positive limit of the PID 1 controller output.										
26.2.9	7620	PID 1 limit neg	perc	FLOAT		0.0	-200	0.0	RW	VS
Setting of the negative limit of the PID 1 controller output.										
26.2.10	7622	PID 1 I limit	perc	FLOAT		100.0	0.0	200.0	RW	VS
Setting of the limit of the PID 1 controller part.										
26.2.11	7624	PID 1 fbk scale		FLOAT		1.0	-10.0	10.0	RW	VS
Setting of a multiplier factor to apply to the feedback used by the PID 1 controller.										
26.2.12	7626	PID 1 out	perc	INT16	16/32BIT	0	0	0	R	VS
The PID 1 controller reference value output is displayed (this parameter is usually connected to the ramp block input).										

Autotuning PID control

This automatic procedure is used to calculate the P (proportional gain) and I (integral gain) coefficients of the PID controller. The D (derivative time) coefficient maintains its initial value.

It is an “open loop” procedure, i.e. to start with the PID is disabled and the pump starts to rotate using a step speed reference. Make sure this actually is possible, otherwise autotuning cannot be performed and the parameters must be calculated by hand.

A transducer of the value being controlled must be connected to the drive input.

With reference to PID 1, to start the procedure:

- 1) Disable the drive.
- 2) Set the drive to “**Local**” mode.
- 3) Set par **1002 Commands local sel** to “**Keypad**”
- 4) Disable the PID controller by setting parameter **PID 1 enable** to **Disable**.
- 5) Set a suitable value for parameter **7632 PID 1 fbk tune thr 1**, , which is equivalent to setting the pump speed of rotation as a % of the speed full scale value (par **680 Full scale speed**).
- 6) Set the range of values allowed for the feedback acquired by the transducer, by setting the values in parameters **7628 PID 1 fbk tune min** and **7630 PID 1 fbk tune max**.
- 7) Enable the drive.

The drive immediately starts the pump, using the value set in point 5) as the step speed reference, bypassing any ramp modes that may have been set.

The drive starts monitoring parameter **7326 PID 1 fbk out mon**.

As soon as this exceeds its initial value by a previously set threshold (equal to 20%) or after a previously set time (equal to 10 mins), the speed setpoint is removed (again bypassing the ramp), the pump stops and waits for the feedback to return to a value close to the initial value.

The progress of the autotuning procedure (shown by "Progress" on the keypad) passes from 0% to 100% and parameters **7606 PID 1 P gain** and **7608 PID 1 I time** are overwritten in real-time with the new, recently calculated values.

During the procedure (which may be aborted at any time by pressing the "ESC" key), the following errors may occur, causing the procedure to abort. The errors and relative codes are displayed on the keypad:

- Error 1** par **1030 Local/remote mon** not 0. The drive is not in "Local" mode.
- Error 2** par **1002 Commands local sel** not set to "Keypad".
- Error 5** Procedure aborted, by pressing the "ESC" key on the keypad or disabling the drive.
- Error 7** the drive is disabled.
- Error 23** par **7632 PID 1 fbk tune thr 1** is 0. The pump cannot rotate.
- Error 24** Feedback value is zero.
Action:
 - Check correct connection and function status of sensor that reads feedback signal.
 - Check feedback programming (Menu 26.1 for PID 1 and Menu 26.3 for PID 2).
- Error 25** Feedback value has not varied sufficiently compared to the original value within a maximum of three minutes. Autotuning is not completed. The variation is configurable with parameters 7632 (for PID 1) and 7682 (for PID 2), see figure on next page.
Action:
 - Check the value set in parameter 7632 or 7682.
 - Check correct connection and function status of sensor that reads feedback signal.
 - Check feedback programming (Menu 26.1 for PID 1 and Menu 26.3 for PID 2)
 - Check for system problems.
- Error 26** Feedback value has fallen below the minimum configured in parameter 7628 (for PID 1) and 7678 (for PID 2), see figure on next page.
Action:
 - Check that value set in parameter 7628 or 7678 is suitable for the type of system.
 - Check for system problems.
- Error 27** Feedback value has exceeded the maximum configured in parameter 7630 (for PID 1) and 7680 (for PID 2), see figure on next page.
Action:
 - Check that value set in parameter 7630 or 7680 is suitable for the type of system.
 - Check for system problems.
- Error 28** Autotuning has ended too quickly, calculating PID values out of the allowed range. The drive is unable to complete autotuning.
Action:
 - Check for system problems.
- Error 29** Autotuning has ended too slowly, calculating PID values out of the allowed range. The drive is unable to complete autotuning.
 - Action: Check for system problems.
- Error 32 and 33** Autotuning has calculated a P gain value out of the allowed range (min and max), as shown in parameter 7606 (for PID 1) and 7656 (for PID 2)
- Error 34 and 35**
Autotuning has calculated an integral time value I out of the allowed range (min and max) as shown in parameter 7608 (for PID 1) and 7658 (for PID 2)

The above is also applicable to the PID 2 function, but points 2) and 3) are not necessary. The drive need not therefore be in "Local" mode.

In the following diagram the solid line shows an example in which threshold 2 is reached, while the broken line shows an example in which threshold 2 is not reached after the timeout. In both cases, PID parameters are calculated and autotuning is correctly completed.

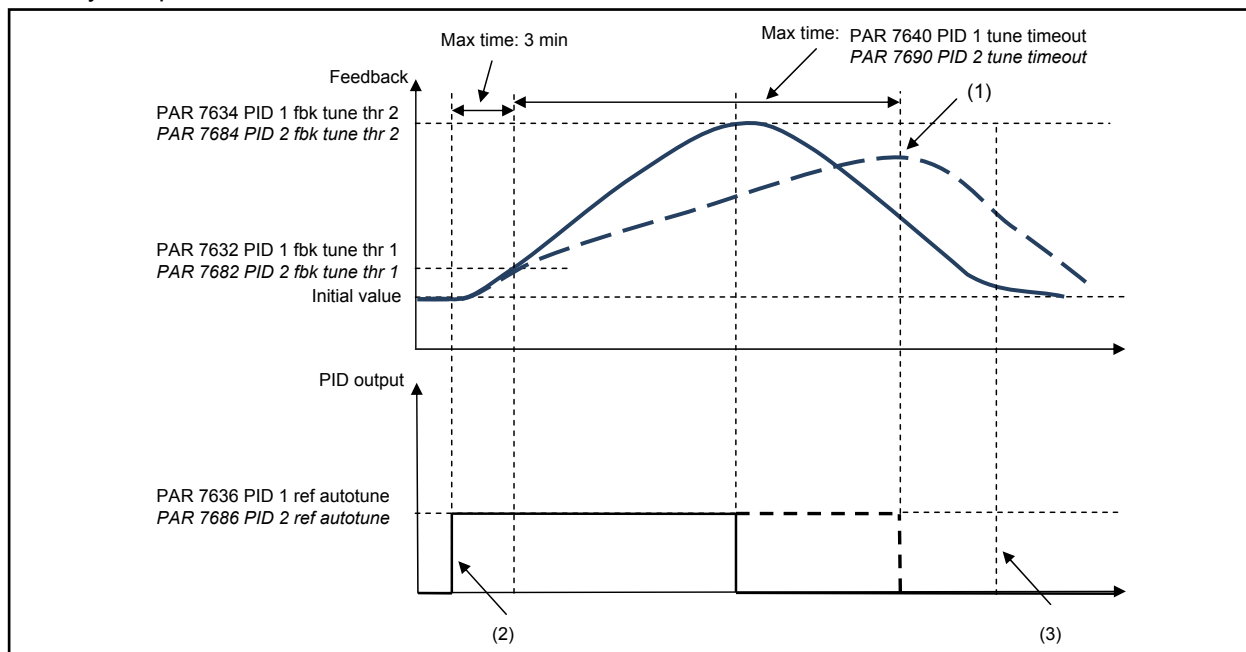

- (1) Feedback signal has not reached threshold 2
- (2) Start PID autotuning
- (3) End PID autotuning

Menu	PAR	Description	UM	Typo	FB BIT	Def	Min	Max	Acc	Mod
26.2.13	7628	PID 1 fbk tune min	PID1U	FLOAT		0.0	0.0	0.0	RW	VS

Setting of the minimum value for the feedback signal during the autotuning procedure.

Menu	PAR	Description	UM	Typo	FB BIT	Def	Min	Max	Acc	Mod
26.2.14	7630	PID 1 fbk tune max	PID1U	FLOAT		100.0	0.0	0.0	RW	VS

Setting of the maximum value for the feedback signal during the autotuning procedure.

Menu	PAR	Description	UM	Typo	FB BIT	Def	Min	Max	Acc	Mod
26.2.15	7632	PID 1 fbk tune thr 1	perc	FLOAT		0.10	0.00	10	RW	VS

Autotuning is interrupted (error 25) if the feedback signal does not reach the set value (expressed as a percentage of full-scale) within three minutes after the start of the autotuning procedure.

Menu	PAR	Description	UM	Typo	FB BIT	Def	Min	Max	Acc	Mod
26.2.16	7634	PID 1 fbk tune thr 2	perc	FLOAT		20.00	1.00	100.00	RW	VS

The maximum value (expressed as a percentage of full-scale) that the feedback signal can reach during the autotuning procedure. When the set value is reached, the PID output is reset and the autotuning procedure is completed.

Menu	PAR	Description	UM	Typo	FB BIT	Def	Min	Max	Acc	Mod
26.2.17	7636	PID 1 ref autotune	perc	INT16		1	1	100	ERW	VS

The digital reference value of the PID output for performing autotuning. The value is a percentage of the full scale speed value (par 680 Full scale speed).

Menu	PAR	Description	UM	Typo	FB BIT	Def	Min	Max	Acc	Mod
26.2.18	7638	PID 1 autotune		BIT		0	0	1	RWZ	VS

Enabling of the autotuning procedure: if this parameter is set to 1 the PID 1 controller autotuning procedure is launched.

Menu	PAR	Description	UM	Typo	FB BIT	Def	Min	Max	Acc	Mod
26.2.17	7640	PID 1 tune timeout	s	UINT16		60	10	600	ERW	VS

If the feedback signal does not reach maximum value par 7634 by the time limit configured with this parameter, the PID output is reset and the autotuning procedure is completed.

26.3 – PROCESS/PID 2 REFERENCES

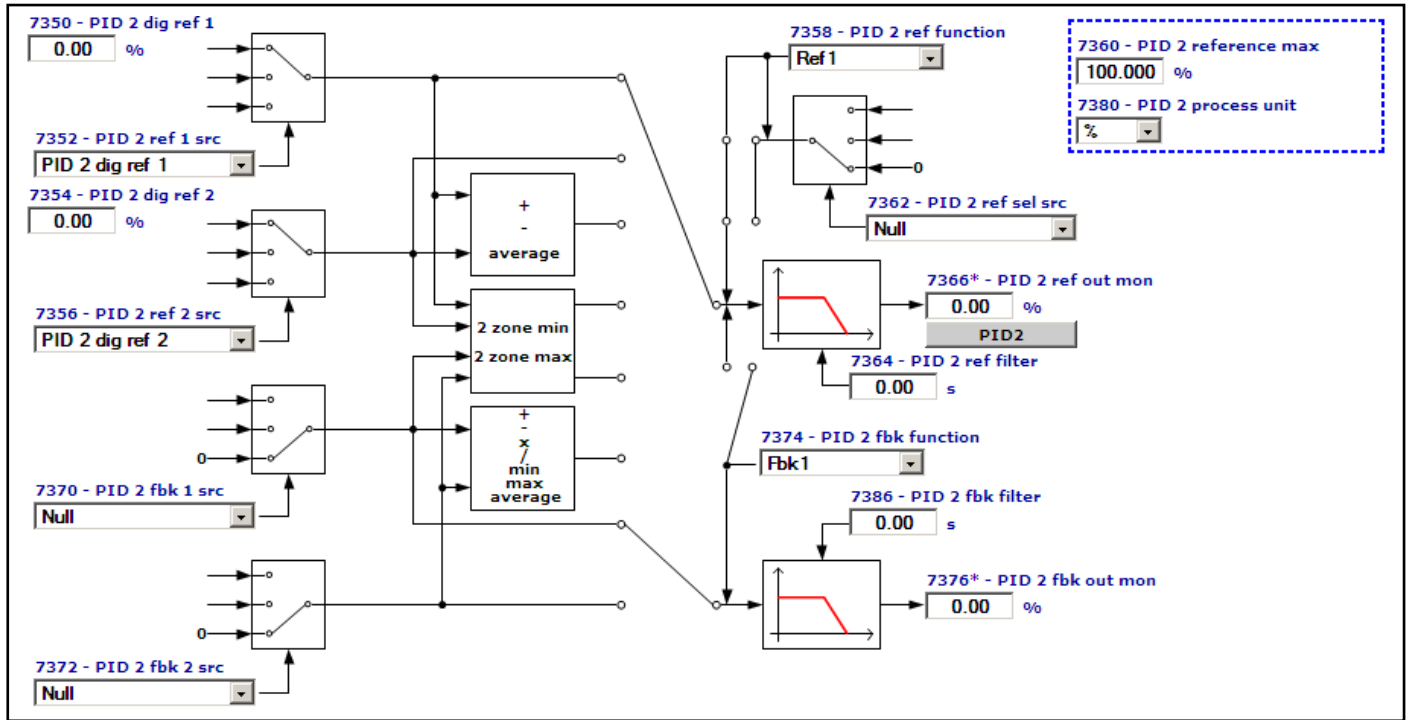

Menu	PAR	Description	UM	Typo	FB BIT	Def	Min	Max	Acc	Mod
26.3.1	7350	PID 2 dig ref 1	PID2U	FLOAT		0.0	CALCF	CALCF	RW	VS

Setting of digital reference 1 for PID 2. This reference defines the setpoint for PID controller functioning.

Menu	PAR	Description	UM	Typo	FB BIT	Def	Min	Max	Acc	Mod
26.3.2	7352	PID 2 ref 1 src		LINK	16/32BIT	7350	0	16384	RW	VS

Selection of the origin (source) of reference signal 1 for the PID 2 setpoint. The PID controller reference values can be selected from those listed in the “L_PIDREF” selection list.

Menu	PAR	Description	UM	Typo	FB BIT	Def	Min	Max	Acc	Mod
26.3.3	7354	PID 2 dig ref 2	PID2U	FLOAT		0.0	CALCF	CALCF	RW	VS

Setting of digital reference 2 for PID 2. This reference defines the setpoint for PID controller functioning.

Menu	PAR	Description	UM	Typo	FB BIT	Def	Min	Max	Acc	Mod
26.3.4	7356	PID 2 ref 2 src		LINK	16/32BIT	7354	0	16384	RW	VS

Selection of the origin (source) of reference signal 2 for the PID 2 setpoint. The PID reference values can be selected from those listed in the “L_PIDREF” selection list.

Menu	PAR	Description	UM	Typo	FB BIT	Def	Min	Max	Acc	Mod
26.3.5	7358	PID 2 ref function		ENUM		Ref1	0	5	RW	VS

This parameter is used to adjust reference 1 and 2 analog input signals for the PID 2 controller:

- 0 Ref1
- 1 Ref2
- 2 Src selection
- 3 Ref1+Ref2
- 4 Ref1-Ref2
- 5 Aver ref1 ref2

Set to **0** to select the value of reference signal 1 as the setpoint for the PID 2 function.

Set to **1** to select the value of reference signal 2 as the setpoint for the PID 2 function.

Set to **2** to select the value of the reference signal 1 or reference signal 2 for the PID 2 function, depending on that selected in parameter **7312 PID 1 ref sel src**.

Set to **3** to select the result of the following formula as the setpoint for the PID 2 function:
 $rif1\ value + (rif2\ value - 50\% \text{ Full scale})$

Set to **4** to select the result of the following formula as the setpoint for the PID 2 function:
 $(rif1\ value + 50\% \text{ Full scale}) - rif2\ value$

Set to **5** to select the arithmetic mean of reference 1 and reference 2 as the setpoint for the PID 1 function.

Menu	PAR	Description	UM	Typo	FB BIT	Def	Min	Max	Acc	Mod
26.3.6	7360	PID 2 reference max		FLOAT		100.0	0.0	999999.0	RW	VS

Setting of the full scale value of the reference in the selected unit of measure.

Important note: when using temperature sensors connected to the EXP-IO_SENS-....-ADV card, this parameter must be set to 180 if values are expressed in °C and 356 if expressed in °F.

Menu	PAR	Description	UM	Typo	FB BIT	Def	Min	Max	Acc	Mod
26.3.7	7362	PID 2 ref sel src		LINK	16BIT	6000	0	16384	RW	VS

Selection of the origin (source) of the PID 2 function reference signal between reference 1 and reference 2.

This setting only applies if parameter **7358 PID 2 ref function** is set to 3 (**Src selection**). PID controller reference signals can be selected from those listed in the "**L_PIDREF**" selection list

Menu	PAR	Description	UM	Typo	FB BIT	Def	Min	Max	Acc	Mod
26.3.8	7364	PID 2 ref filter	s	FLOAT		0.0	0.0	10.0	RW	VS

Setting of the value of the filter applied to the reference signal.

Menu	PAR	Description	UM	Typo	FB BIT	Def	Min	Max	Acc	Mod
26.3.9	7366	PID 2 ref out mon	PID2U	FLOAT		0.0	0.0	0.0	R	VS

The current value of the selected reference is displayed.

Menu	PAR	Description	UM	Typo	FB BIT	Def	Min	Max	Acc	Mod
26.3.10	7370	PID 2 fbk 1 src		LINK	16/32BIT	6000	0	16384	RW	VS

Selection of the origin (source) of feedback signal 1 for the PID 2 function. The PID controller feedback signals can be selected from those listed in the "**L_PIDFBK**" selection list.

Menu	PAR	Description	UM	Typo	FB BIT	Def	Min	Max	Acc	Mod
26.3.11	7372	PID 2 fbk 2 src		LINK	16/32BIT	6000	0	16384	RW	VS

Selection of the origin (source) of feedback signal 2 for the PID 2 function. The PID controller feedback signals can be selected from those listed in the "**L_PIDFBK**" selection list.

Menu	PAR	Description	UM	Typo	FB BIT	Def	Min	Max	Acc	Mod
26.3.12	7374	PID 2 fbk function		ENUM		Fbk1	0	10	RW	VS

Selection of the operation to be executed on feedback signals 1 and 2 for the PID 2 controller:

- 0 Fbk1
- 1 Fbk2
- 2 Fbk1+Fbk2
- 3 Fbk1-Fbk2
- 4 Fbk1*Fbk2
- 5 Fbk1/Fbk2
- 6 Min fbk1fbk2
- 7 Max fbk1fbk2

8 Aver fbk1 fbk2

9 2 Zone min

10 2 Zone max

Set to **0** to select the value of feedback signal 1 as the feedback for the PID 2 function.

Set to **1** to select the value of feedback signal 2 as the feedback for the PID 2 function.

Set to **2** to select the result of the following formula as the feedback for the PID 2 function:

fbk1 value+(fbk2 value-50% Full scale)

Set to **3** to select the result of the following formula as the feedback for the PID 2 function:

(fbk1 value+50% Full scale)-fbk2 value)

Set to **4** to select the result of the following formula as the feedback for the PID 2 function:

(fbk1 value(fbk2 value/50% Full scale)*

Set to **5** to select the result of the following formula as the feedback for the PID 2 function:

*(fbk1 value*50% Full scale) / fbk2 value)*

Set to **6** to select the lower value between feedback 1 and feedback 2 as the feedback for the PID 2 function.

Set to **7** to select the higher value between feedback 1 and feedback 2 as the feedback for the PID 2 function.

Set to **8** to select the arithmetic mean of feedback 1 and feedback 2 as the feedback for the PID 2 function.

Set to **9** to calculate the differences between ref1-fbk1 and ref2-fbk2 and use the values equal to the smaller difference for the PID 2 function.

Set to **10** to calculate the differences between ref1-fbk1 and ref2-fbk2 and use the values equal to the greater difference for the PID 2 function.

Menu	PAR	Description	UM	Typo	FB BIT	Def	Min	Max	Acc	Mod
26.3.13	7386	Pid 2 fbk filter	s	FLOAT		0.0	0.0	10.0	RW	VS
Setting of the value of the filter applied to the feedback signal.										

Menu	PAR	Description	UM	Typo	FB BIT	Def	Min	Max	Acc	Mod
26.3.14	7376	PID 2 fbk out mon	PID2U	FLOAT		0.0	0.0	0.0	R	VS
The current value of the selected feedback is displayed.										

Menu	PAR	Description	UM	Typo	FB BIT	Def	Min	Max	Acc	Mod
26.3.15	7380	PID 2 process unit		ENUM		%	0	39	RW	VS
Use this parameter to select the unit of measure used in the process.										

0

1 %

2 rpm

3 ppm

4 imp/s

5 l/s

6 l/m

7 l/h

8 kg/s

9 kg/m

- 10 kg/h
- 11 m³/s
- 12 m³/m
- 13 m³/h
- 14 m/s
- 15 mbar
- 16 bar
- 17 Pa
- 18 kPa
- 19 m
- 20 m ca
- 21 kW
- 22 °C
- 23 °F
- 24 GPM
- 25 gal/s
- 26 gal/m
- 27 gal/h
- 28 lb/s
- 29 lb/m
- 30 lb/h
- 31 CFM
- 32 ft³/s
- 33 ft³/m
- 34 ft³/h
- 35 ft/s
- 36 in wg
- 37 ft wg
- 38 PSI
- 39 Lb/i²

26.4 – PROCESS/ PID 2

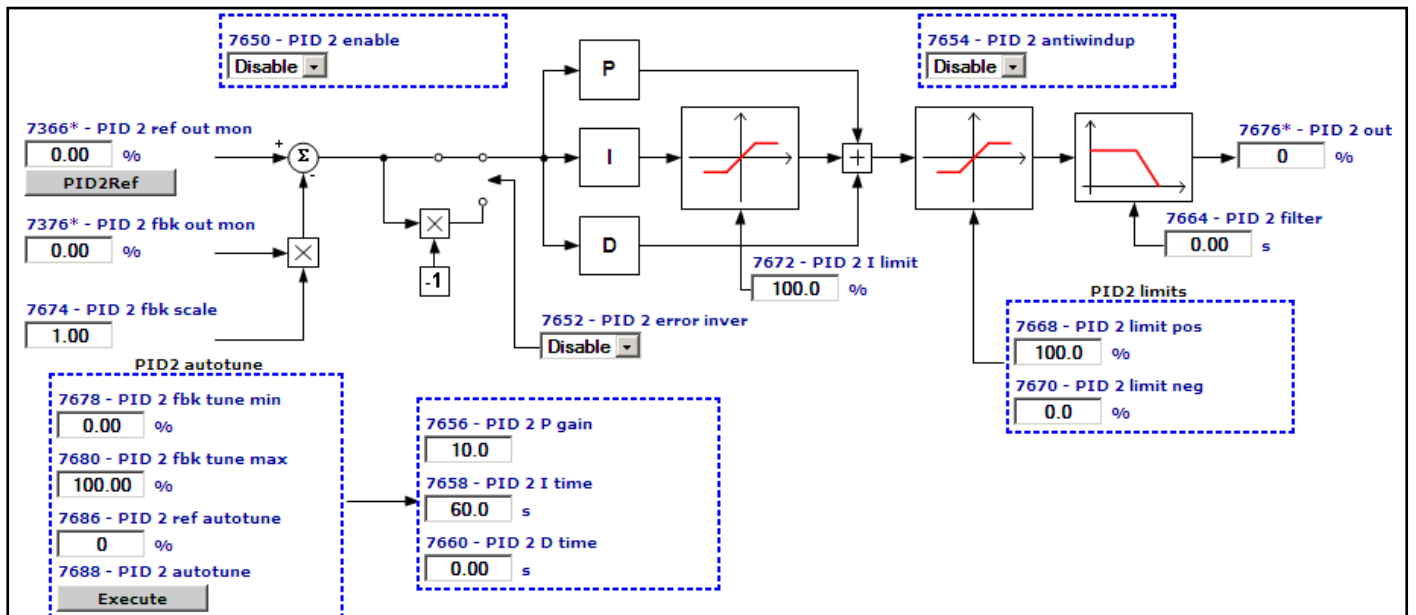

Menu	PAR	Description	UM	Typo	FB BIT	Def	Min	Max	Acc	Mod
26.4.1	7650	PID 2 enable		ENUM		Disable	0	1	RWZ	VS

Enabling of the PID 2 controller.

- 0 Disable
- 1 Enable

Set to **0** to disable the PID 2 function.

Set to **1** to enable the PID 2 function.

Menu	PAR	Description	UM	Typo	FB BIT	Def	Min	Max	Acc	Mod
26.4.2	7652	PID 2 error inver		ENUM		Disable	0	1	RWZ	VS

Use this parameter to invert the error calculated by PID 2.

- 0 Disable
- 1 Enable

If set to **0** the error calculated by the PID is not inverted.

If set to **1** the error calculated by the PID is inverted.

Menu	PAR	Description	UM	Typo	FB BIT	Def	Min	Max	Acc	Mod
26.4.3	7654	PID 2 antiwindup		PID1U ENUM		Disable	0	1	RWZ	VS

Use this parameter to enable the PID anti-saturation (wind-up) function.

- 0 Disable
- 1 Enable

If set to **0** the value of the integrator continues to change even when the output has reached one of the limits (minimum or maximum motor speed), delaying any changes in the inverter output.

If set to **1** the integrator value is blocked if the output of the PID 2 controller has reached one of the limits (minimum or maximum motor speed) and is unable to add further changes to the value of the process parameter being controlled. In this condition the drive reacts more quickly once the PID 2 controller output returns to within the limits.

Menu	PAR	Description	UM	Typo	FB BIT	Def	Min	Max	Acc	Mod
26.4.4	7656	PID 2 P gain		FLOAT	16/32BIT	10.0	0.0	100.0	RW	VS

Setting of the integral gain of the PID 2 controller.

Menu	PAR	Description	UM	Typo	FB BIT	Def	Min	Max	Acc	Mod
26.4.5	7658	PID 2 I time	s	FLOAT		60.0	0.0	3600.0	RW	VS

Setting of the integral time of the PID 2 controller.

Menu	PAR	Description	UM	Typo	FB BIT	Def	Min	Max	Acc	Mod
26.4.6	7660	PID 2 D time	s	FLOAT		0.0	0.0	1.0	RW	VS

Setting of the derivative time of the PID 2 controller.

Menu	PAR	Description	UM	Typo	FB BIT	Def	Min	Max	Acc	Mod
26.4.7	7664	PID 2 filter	s	FLOAT		0.0	0.0	10.0	RW	VS

Setting of the time constant used for the PID 2 output filter.

Menu	PAR	Description	UM	Typo	FB BIT	Def	Min	Max	Acc	Mod
26.4.8	7668	PID 2 limit pos	perc	FLOAT		100.0	0.0	200.0	RW	VS

Setting of the positive limit of the PID 2 controller output.

Menu	PAR	Description	UM	Typo	FB BIT	Def	Min	Max	Acc	Mod
26.4.9	7670	PID 2 limit neg	perc	FLOAT		0.0	-200	0.0	RW	VS

Setting of the negative limit of the PID 2 controller output.

Menu	PAR	Description	UM	Typo	FB BIT	Def	Min	Max	Acc	Mod
26.4.10	7672	PID 2 I limit	perc	FLOAT		100.0	0.0	200.0	RW	VS

Setting of the limit of the PID 2 controller part.

Menu	PAR	Description	UM	Typo	FB BIT	Def	Min	Max	Acc	Mod
26.4.11	7674	PID 2 fbk scale		FLOAT		1.0	-10.0	10.0	RW	VS

Setting of a multiplier factor to apply to the feedback used by the PID 2 controller.

Menu	PAR	Description	UM	Typo	FB BIT	Def	Min	Max	Acc	Mod
26.4.12	7676	PID 2 out	perc	INT16	16/32BIT	0	0	0	R	VS

The PID 2 controller reference value output is displayed (this parameter is usually connected to the ramp block input).

Menu	PAR	Description	UM	Typo	FB BIT	Def	Min	Max	Acc	Mod
26.2.13	7678	PID 2 fbk tune min	PID1U	FLOAT		0.0	0.0	0.0	RW	VS

Setting of the minimum value for the feedback signal during the autotuning procedure.

Menu	PAR	Description	UM	Typo	FB BIT	Def	Min	Max	Acc	Mod
26.4.14	7680	PID 2 fbk tune max	PID1U	FLOAT		100.0	0.0	0.0	RW	VS

Setting of the maximum value for the feedback signal during the autotuning procedure.

Menu	PAR	Description	UM	Typo	FB BIT	Def	Min	Max	Acc	Mod
26.4.15	7682	PID 2 fbk tune thr 1	perc	FLOAT		0.10	0.00	10	ERW	VS

Autotuning is interrupted (error 25) if the feedback signal does not reach the set value (expressed as a percentage of full-scale) within three minutes after the start of the autotuning procedure.

Menu	PAR	Description	UM	Typo	FB BIT	Def	Min	Max	Acc	Mod
26.4.16	7684	PID 2 fbk tune thr 2	perc	FLOAT		20.00	1.00	100.00	ERW	VS

The maximum value (expressed as a percentage of full-scale) that the feedback signal can reach during the autotuning procedure. When the set value is reached, the PID output is reset and the autotuning procedure is completed.

Menu	PAR	Description	UM	Typo	FB BIT	Def	Min	Max	Acc	Mod
26.4.17	7686	PID 2 ref autotune	perc	INT16		0	0	100	ERW	VS

The digital reference value of the PID output for performing autotuning. The value is a percentage of the full scale speed value (par **680 Full scale speed**).

Menu	PAR	Description	UM	Typo	FB BIT	Def	Min	Max	Acc	Mod
26.4.18	7688	PID 2 autotune		BIT		0	0	1	RWZ	VS

Enabling of the autotuning procedure: if this parameter is set to 1 the PID 2 controller autotuning procedure is launched.

Menu	PAR	Description	UM	Typo	FB BIT	Def	Min	Max	Acc	Mod
26.4.19	7690	PID 2 tune timeout	s	UINT16		60	10	600	ERW	VS

If the feedback signal does not reach maximum value par 7634 by the time limit configured with this parameter, the PID output is reset and the autotuning procedure is completed.

26.5 – PROCESS/SLEEP MODE

If no flow is required, the PID controller is able to maintain the pressure reference value with the pump running slowly. If this condition is maintained for some time, the pump can be stopped to save energy. The drive is disabled during sleep. The feedback is always monitored and when it falls below a previously set threshold the pump is re-started.

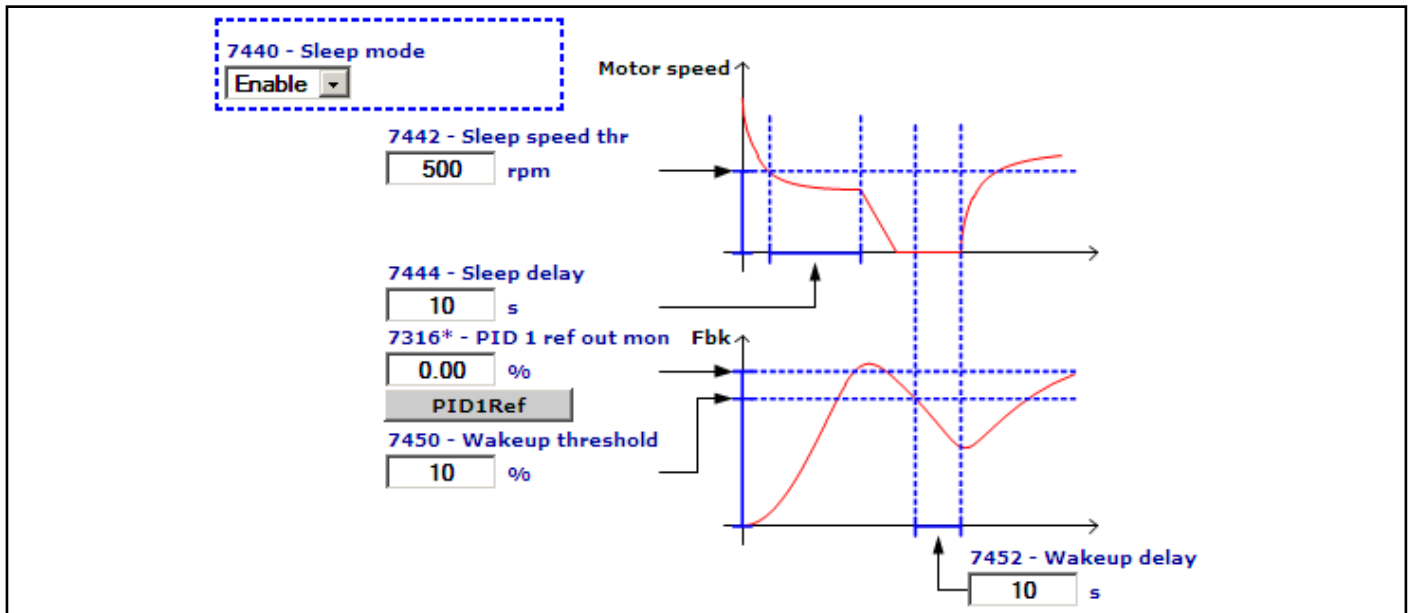

Menu	PAR	Description	UM	Typo	FB BIT	Def	Min	Max	Acc	Mod
26.5.1	7440	Sleep mode		ENUM		Disable	0	1	RW	VS

Enabling of Sleep mode.

- 0 Disable
- 1 Enable

Set to **0** to disable Sleep mode.

Set to **1** to enable Sleep mode.

Menu	PAR	Description	UM	Typo	FB BIT	Def	Min	Max	Acc	Mod
26.5.2	7442	Sleep speed thr	rpm	INT16		500	0	CALCI	RW	VS

This parameter defines the speed threshold below which, after the time set in parameter **7444 Sleep delay**, the drive enters sleep mode and stops the motor. In this phase the actual motor speed may be higher than that calculated by the PID because the lower limit is defined by parameter **636 Ramp ref bottom lim**.

Menu	PAR	Description	UM	Typo	FB BIT	Def	Min	Max	Acc	Mod
26.5.3	7444	Sleep delay	s	INT16		10	0	600	RW	VS

Setting of the delay, when the motor speed is below the speed set in parameter **7442 Sleep speed thr**, after which the drive enters sleep mode and stops the motor.

Menu	PAR	Description	UM	Typo	FB BIT	Def	Min	Max	Acc	Mod
26.5.4	7446	Const pressure thr	perc	INT16		0	0	100	RW	VS

Setting of the threshold above which, after the time set in parameter **7448 Const press thr time**, the drive enters sleep mode and stops the motor in the “Constant pressure” condition.

This parameter is set as a percentage of reduction of the current PID reference value.

For example, with a PID reference to 50 bar and a constant pressure threshold (par. 7446) set to 10 %, the constant pressure function is enabled when the feedback is over the value of $50 - 50 \cdot 10\% = 45$ bar.

This parameter is set to 0, the “Constant pressure” function is disabled.

Menu	PAR	Description	UM	Typo	FB BIT	Def	Min	Max	Acc	Mod
26.5.5	7448	Const press thr time	s	INT16		10	0	600	RW	VS

Setting of the delay, when the pressure is higher than the value set in parameter **7446 Const pressure thr**, after which the drive enters sleep mode and stops the motor in the “Constant pressure” condition.

Menu	PAR	Description	UM	Typo	FB BIT	Def	Min	Max	Acc	Mod
26.5.6	7450	Wakeup threshold	perc	INT16		10	0	100	RW	VS

This parameter defines the error threshold (expressed as a percentage of the setpoint) above which, after the time set in parameter **7452 Wakeup delay**, the drive exits sleep mode and restarts the motor.

Menu	PAR	Description	UM	Typo	FB BIT	Def	Min	Max	Acc	Mod
26.5.7	7452	Wakeup delay	s	INT16		10	0	600	RW	VS

Setting of the delay, if the request by the PID controller is more than the limit set in parameter **7450 Wakeup threshold**, after which the drive exits sleep mode and restarts the motor.

Menu	PAR	Description	UM	Typo	FB BIT	Def	Min	Max	Acc	Mod
26.5.8	7454	Fluid loss thr	perc	INT16		10	0	50	RW	VS

If the drive is in the “Constant pressure” condition, any loss of pressure in the system in excess of that set with this parameter in a time defined by **7456 Fluid loss time** causes the motor to restart.

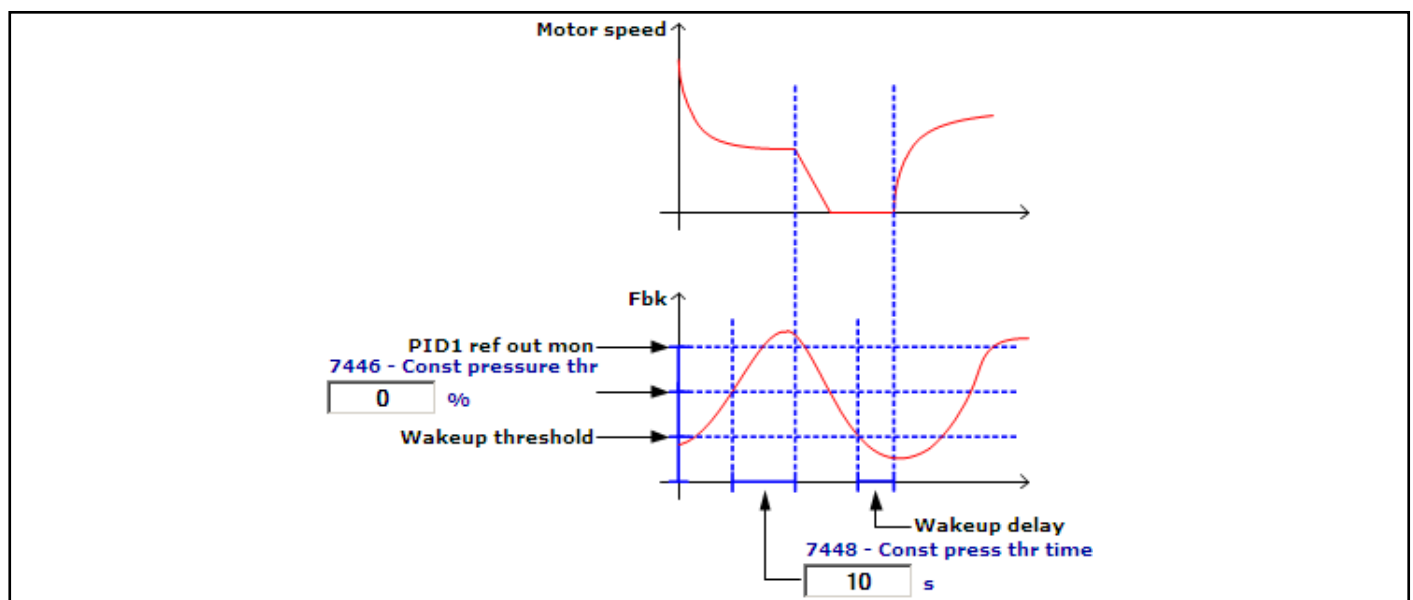

Menu	PAR	Description	UM	Typo	FB BIT	Def	Min	Max	Acc	Mod
26.5.9	7456	Fluid loss time	s	INT16		10	0	600	RW	VS

If there is a loss of pressure which exceeds the threshold set in parameter **7454 Fluid loss thr**, and occurs within a shorter time than that set in this parameter, the drive exits the constant pressure condition and the motor restarts.

Menu	PAR	Description	UM	Typo	FB BIT	Def	Min	Max	Acc	Mod
26.5.10	7458	Boost value	perc	FLOAT		0.0	0.0	100.0	RW	VS

This function is used to prevent the motor switching off and restarting too frequently.

The pressure in the system is increased before stopping the motor to delay subsequent restarting. To obtain this effect, the reference is raised to a value set in this parameter for the time set in parameter 7460 Boost duration, before moving to the sleep condition.

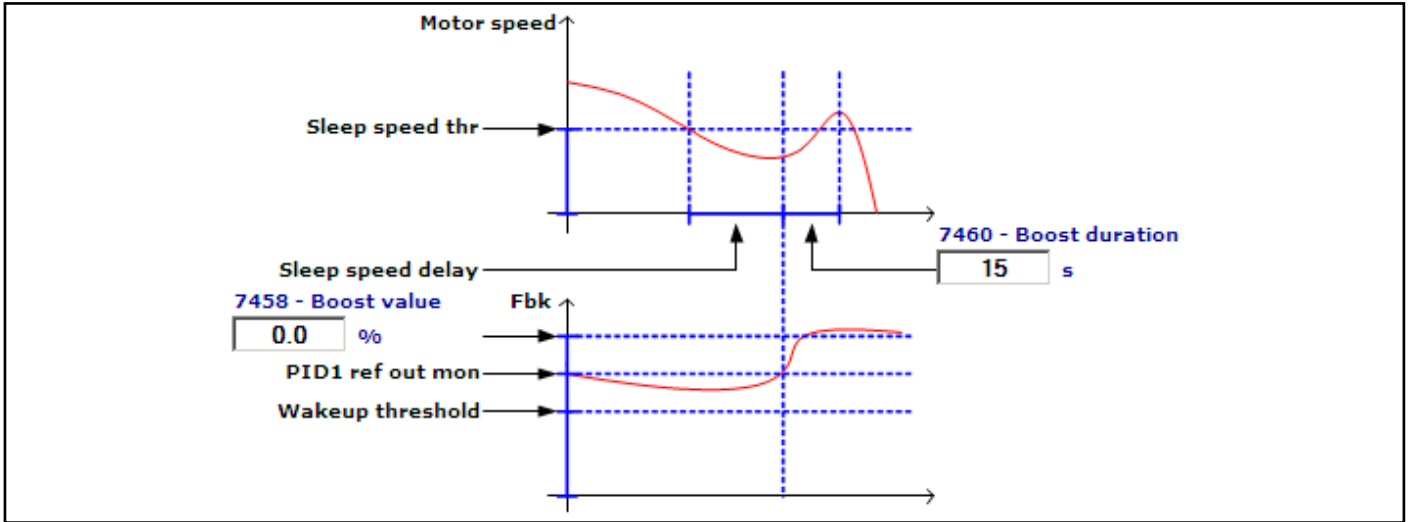

Menu	PAR	Description	UM	Typo	FB BIT	Def	Min	Max	Acc	Mod
26.5.11	7460	Boost duration	s	INT16		15	0	600	RW	VS

Setting of the time for which the pressure is increased before entering sleep mode.

Menu	PAR	Description	UM	Typo	FB BIT	Def	Min	Max	Acc	Mod
26.5.12	7462	Sleep active mon		BIT	16BIT	0	0	1	R	VS

The drive status is displayed: a value of 1 indicates that the drive is in sleep mode.

Displays pump Pause status: pump pause status can be displayed by means of a digital output selected from the L_DISEL1 list.

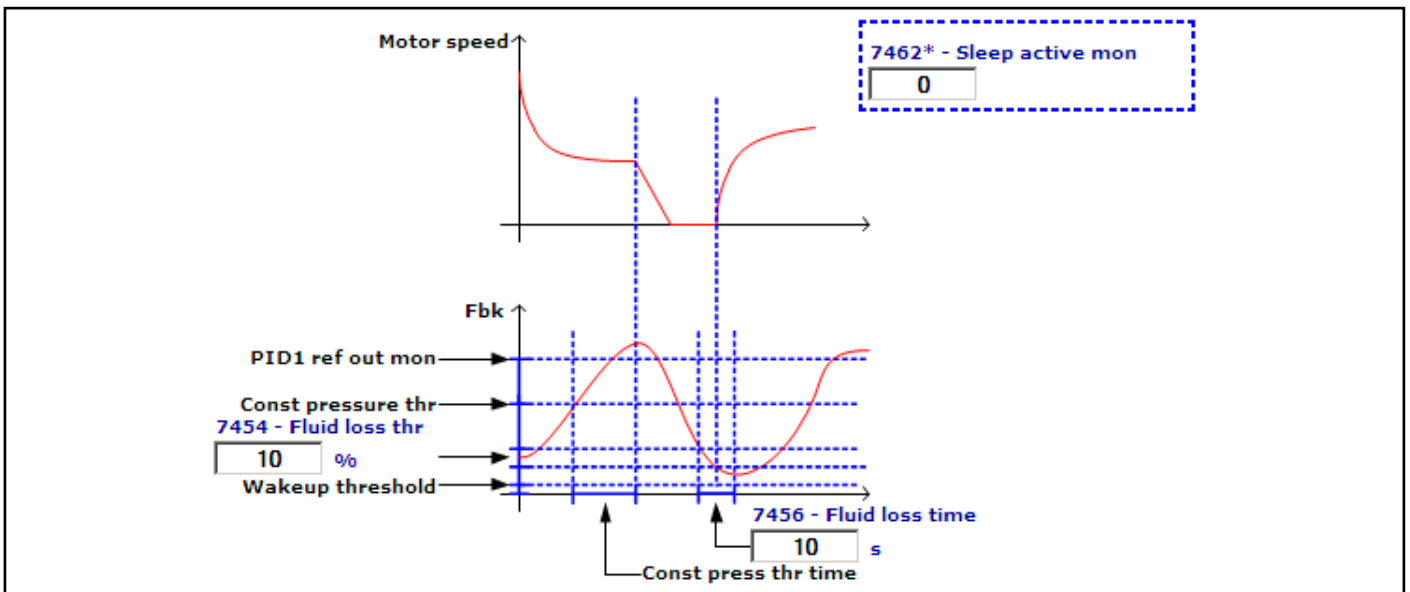

26.6 – PROCESS/FLOW COMPENS

In most hydraulic systems the pressure near the liquid delivery point must be maintained constant. However, the pressure transducer may have to be installed near the pump, since it is not always possible to install it at that point. In that case, the fact that load losses can vary according to flow capacity must be taken into account.

When flow capacity is reduced, due to a reduction in demand, load losses also fall, so it is also a good idea to reduce the delivery pressure to try to keep the pressure at the delivery point constant. The opposite applies when the flow rate increases.

In practice, the drive adjusts the reference according to the speed on the basis of a previously defined speed-pressure curve. This is a quadratic curve that passes through 2 points programmed in the drive:

Point 1: zero flow capacity point = zero flow capacity speed, zero flow capacity pressure

Point 2: operating point = design speed, design pressure

To adjust the curve to the actual operating conditions there is a correction parameter that flattens the curve until it becomes a straight line that passes through the same 2 points.

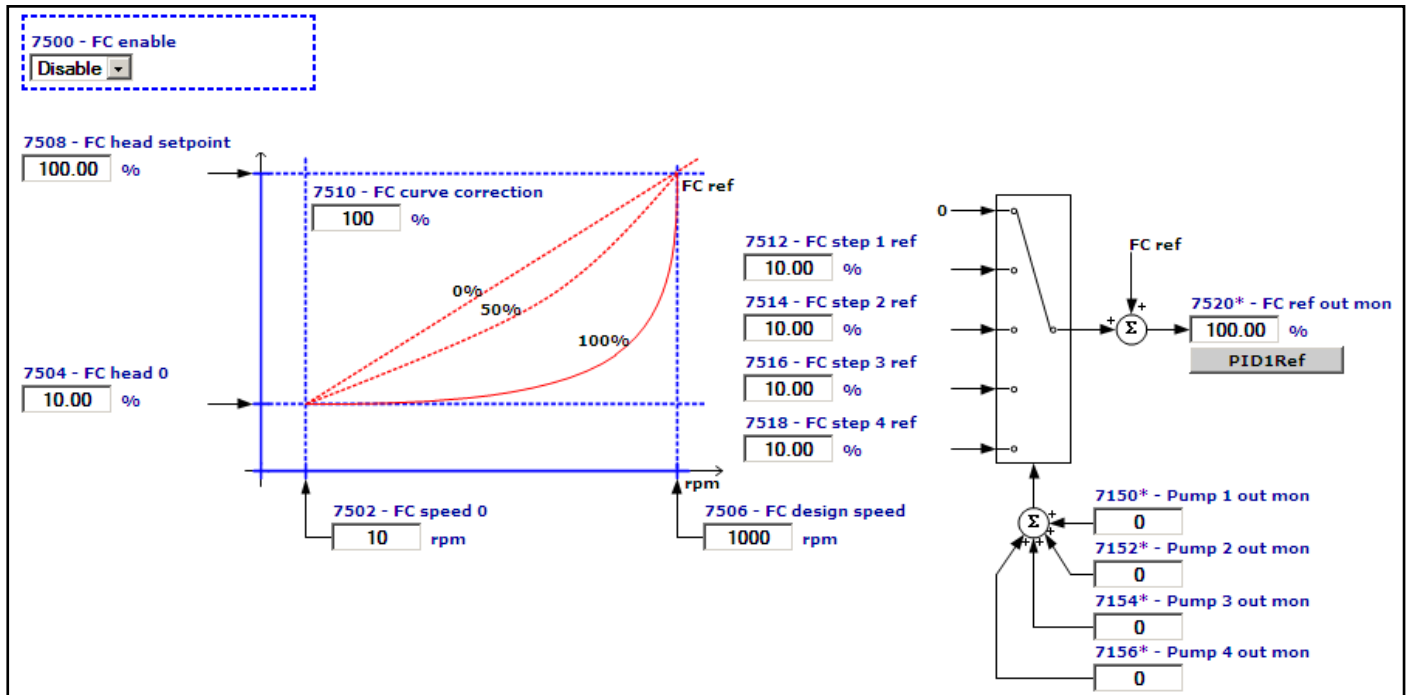

Menu	PAR	Description	UM	Typo	FB BIT	Def	Min	Max	Acc	Mod
26.6.1	7500	FC enable			ENUM	Disable	0	1	RW	VS

Enabling of flow compensation calculation.

0 Disable

1 Enable

Set to 0 to disable flow compensation.

Set to 1 to enable flow compensation.

Menu	PAR	Description	UM	Typo	FB BIT	Def	Min	Max	Acc	Mod
26.6.2	7502	FC speed 0	rpm	INT16		10	0	CALCI	RW	VS

Setting of the speed at the zero flow capacity point. This value depends on system characteristics.

Menu	PAR	Description	UM	Typo	FB BIT	Def	Min	Max	Acc	Mod
26.6.3	7504	FC head 0	PID1U	FLOAT		10.0	0.0	1000.0	RW	VS

Setting of the pressure at the zero flow capacity point. This value depends on system characteristics.

Menu	PAR	Description	UM	Typo	FB BIT	Def	Min	Max	Acc	Mod
26.6.4	7506	FC design speed	rpm	INT16		1000	0	CALCI	RW	VS

Setting of the speed at the operating point. This value depends on system design characteristics.

Menu	PAR	Description	UM	Typo	FB BIT	Def	Min	Max	Acc	Mod
26.6.5	7508	FC head setpoint	PID1U	FLOAT		100.0	0.0	1000.0	RW	VS
Setting of the pressure at the operating point. This value depends on system design characteristics.										
Menu	PAR	Description	UM	Typo	FB BIT	Def	Min	Max	Acc	Mod
26.6.6	7510	FC curve correction	perc	UINT16		100	0	100	RW	VS
This parameter is used to set a curve correction factor. In other words, the compensation curve is flattened until it becomes a straight line that passes through the 2 setpoints. If the correction coefficient is set to 0% compensation is equal to a straight line. If the correction coefficient is set to 100% compensation is equal to a quadratic curve.										
Menu	PAR	Description	UM	Typo	FB BIT	Def	Min	Max	Acc	Mod
26.6.7	7512	FC step 1 ref		FLOAT		10.0	0.0	1000.0	RW	VS
Setting of the offset to add to parameter 7520 FC ref out mon when a pump is active. When cascade pump management is active, the contribution of the pumps at fixed speed must be added to the calculated reference value.										
Menu	PAR	Description	UM	Typo	FB BIT	Def	Min	Max	Acc	Mod
26.6.8	7514	FC step 2 ref		FLOAT		10.0	0.0	1000.0	RW	VS
Setting of the offset to add to parameter 7520 FC ref out mon when two pumps are active.										
Menu	PAR	Description	UM	Typo	FB BIT	Def	Min	Max	Acc	Mod
26.6.9	7516	FC step 3 ref		FLOAT		10.0	0.0	1000.0	RW	VS
Setting of the offset to add to parameter 7520 FC ref out mon when three pumps are active.										
Menu	PAR	Description	UM	Typo	FB BIT	Def	Min	Max	Acc	Mod
26.6.10	7518	FC step 4 ref		FLOAT		10.0	0.0	1000.0	RW	VS
Setting of the offset to add to parameter 7520 FC ref out mon when four pumps are active.										
Menu	PAR	Description	UM	Typo	FB BIT	Def	Min	Max	Acc	Mod
26.6.11	7520	FC ref out mon		FLOAT		0	0	1000.0	R	VS
The compensated reference value output by the compensation block is displayed. This value is only calculated if the flow compensation function is enabled. This parameter must be connected to the PID 1 reference source.										

26.7 – PROCESS/FILL

The purpose of the filling function is to avoid water hammering when a system is filled too quickly.

Different methods must be used to fill the horizontal and vertical pipes: in horizontal pipes the pressure does not increase during filling, whereas in vertical pipes it increases as the water level rises.

It is a good idea, when filling horizontal pipes, to maintain a constant rpm for a previously set time, whereas vertical pipes should be filled according to a pressure ramp with previously defined slope to reach a set pressure. For mixed pipes use a combination of the two methods.

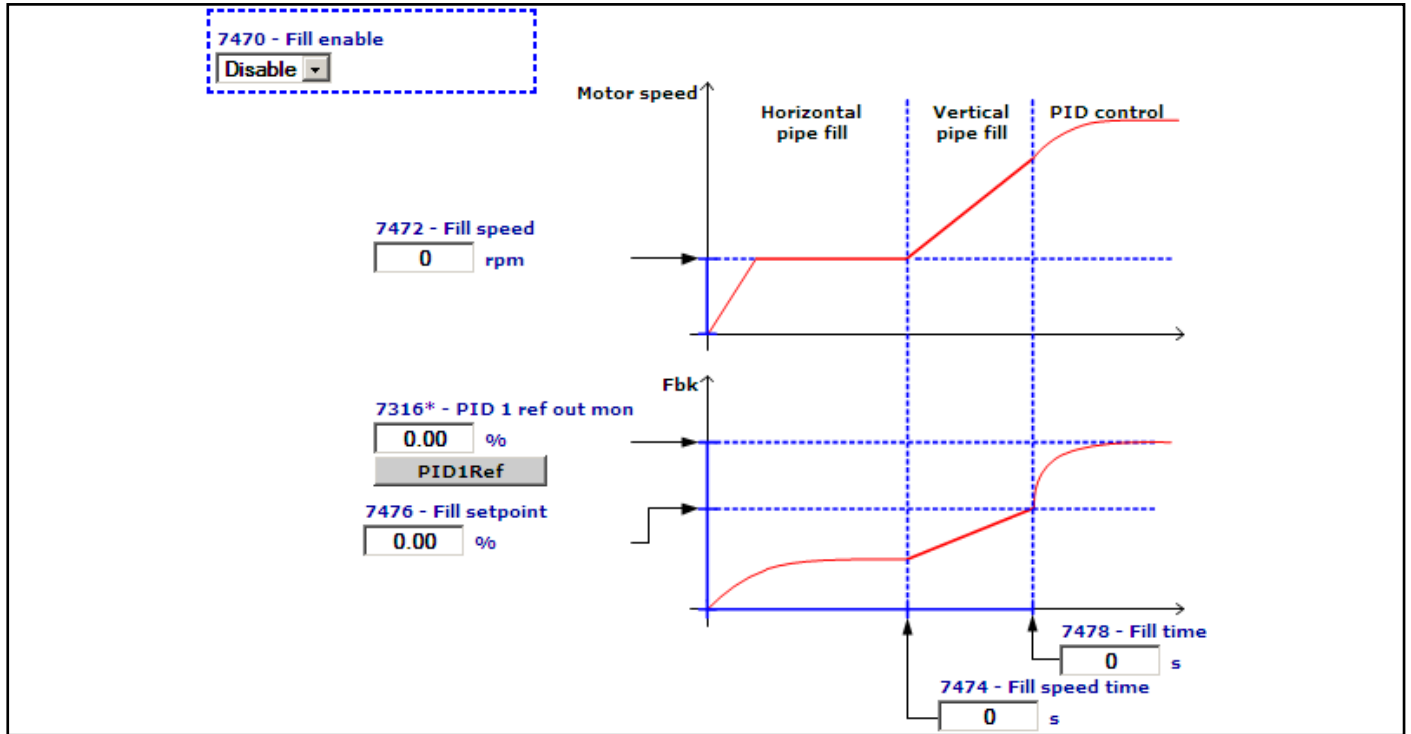

Controlled filling is performed in two stages:

Stage 1 (horizontal pipes): The pump runs at **Fill speed** for **Fill speed time**. This stage cannot be performed if **Fill speed time** = 0 (which is the default setting).

Stage 2 (vertical pipes): this stage is enabled after stage 1. The pressure reference is increased up to the value of **Fill setpoint** in **Fill speed time**. When the reference applied reaches the setpoint, the system enters normal operating mode with the PID controlling the main reference. This stage may be skipped by setting **Fill setpoint** = 0 (which is the default setting) and moving directly to **normal PID** control.

The “Fill” function is performed each time the system is started.

Menu	PAR	Description	UM	Typo	FB BIT	Def	Min	Max	Acc	Mod
26.7.1	7470	Fill enable		ENUM		Disable	0	1	RW	VS

Enabling of the fill function.

- 0 Disable
- 1 Enable

Set to 0 to disable the fill function.

Set to 1 to enable the fill function.

Menu	PAR	Description	UM	Typo	FB BIT	Def	Min	Max	Acc	Mod
26.7.2	7472	Fill speed	rpm	INT16		0	0	CALCI	RW	VS

Setting of the pump speed during horizontal pipe fill.

Menu	PAR	Description	UM	Typo	FB BIT	Def	Min	Max	Acc	Mod
26.7.3	7474	Fill speed time	s	INT16		0.0	0.0	3600.0	RW	VS

Setting of the duration of horizontal pipe fill. If this parameter is set to 0 the drive does not perform this pipe fill stage.

Menu	PAR	Description	UM	Typo	FB BIT	Def	Min	Max	Acc	Mod
26.7.4	7476	Fill setpoint	PID1U	FLOAT		0.0	CALCF	CALCF	RW	VS

Setting of the value that the reference must reach during vertical pipe fill, with a constant slope. If this parameter is set to 0 the drive does not perform this pipe fill stage.

Menu	PAR	Description	UM	Typo	FB BIT	Def	Min	Max	Acc	Mod
26.7.5	7478	Fill time	s	INT16		0.0	0.0	3600	RW	VS

Setting of the duration of vertical pipe fill. During this time the reference is brought to the value entered in parameter **7476 Fill setpoint**.

Menu	PAR	Description	UM	Typo	FB BIT	Def	Min	Max	Acc	Mod
26.7.6	7492	Fill enable src		LINK	16BIT	7470	0	16384	ERW	VS

Disable the Fill function via an external source, to avoid the filling of the tubes at each start of the pump (default).

Changed the default setting, the Fill function will be activated only when are active both PAR 7470 **Fill enable** and the source associated to PAR 7492 **Fill enable src**.

In this way it could, for example via a digital input, fill a plant only the first time and skip the filling subsequent times when it is already full.

26.8 – PROCESS/MIN FREQUENCY

Some pumps, e.g. immersion pumps, can be damaged if they run too slowly for too long. They must therefore reach a minimum speed within the shortest possible time.

If the speed is less than the minimum speed, the ramp defined by the parameters described below is used.

This applies for both ramping up and ramping down.

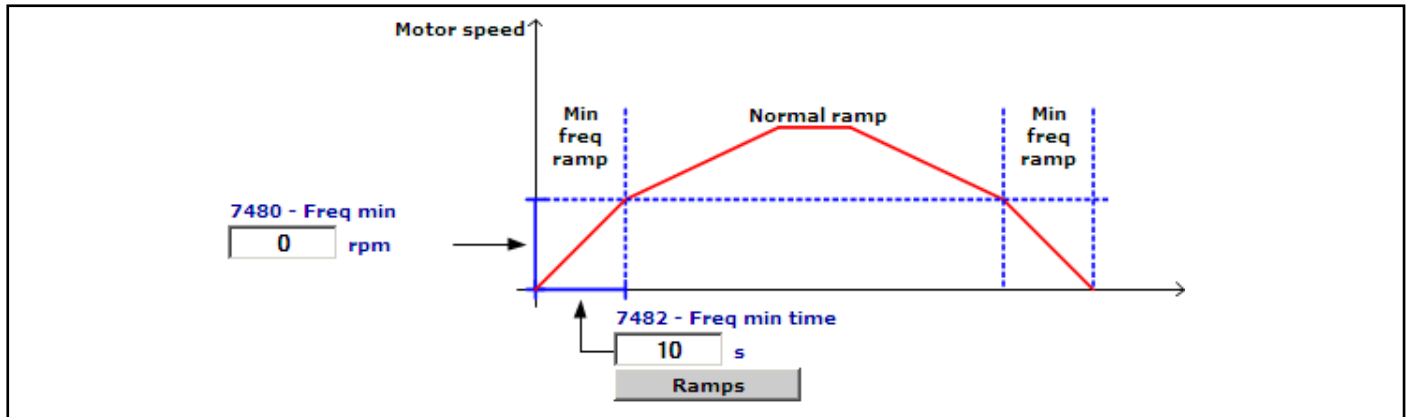

Menu	PAR	Description	UM	Typo	FB BIT	Def	Min	Max	Acc	Mod
26.8.1	7480	Freq min	rpm	INT16		0	0	CALCI	RW	VS

Setting of the speed to reach in the time set in parameter **7482 Freq min time**.

Menu	PAR	Description	UM	Typo	FB BIT	Def	Min	Max	Acc	Mod
26.8.2	7482	Freq min time	s	UINT16		10	1	3600	RW	VS

Setting of the time within which the minimum speed value set in parameter **7480 Freq min** must be reached.

26.9 – PROCESS/CHECK VALVE

This function is used to avoid excessive stress on the check valves if the pump is switched off too quickly.

Ramping down is performed normally up to **Check valve spd hi**; this speed must be set to a value that is just above the speed at which the check valve closes. From that moment the pump reaches the **Check valve spd low**, at which the check valve is assumed to be closed, in the time set in **Check valve time**. Then normal ramping resumes until the system is switched off.

This function is not used for ramping up.

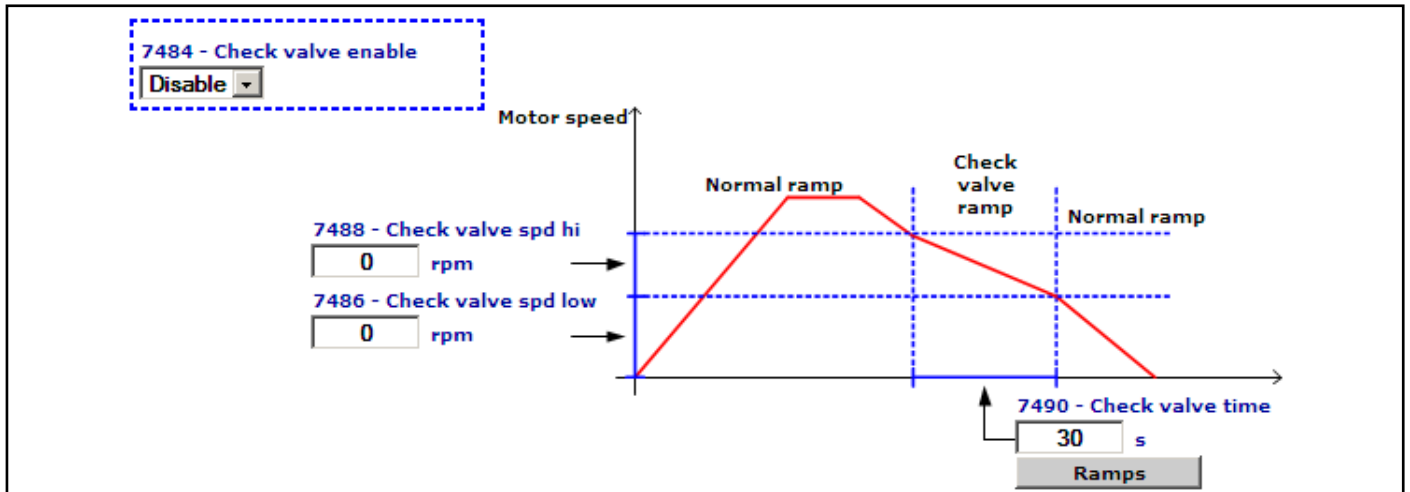

Menu	PAR	Description	UM	Typo	FB BIT	Def	Min	Max	Acc	Mod
26.9.1	7484	Check valve enable		ENUM		Disable	0	1	RW	VS

Enabling of the check valve function.

- 0 Disable
- 1 Enable

Set to **0** to disable the check valve function.

Set to **1** to enable the check valve function.

Menu	PAR	Description	UM	Typo	FB BIT	Def	Min	Max	Acc	Mod
26.9.2	7486	Check valve spd low	rpm	INT16		0	0	CALCI	RW	VS

Setting of the speed at which normal ramping is resumed.

Menu	PAR	Description	UM	Typo	FB BIT	Def	Min	Max	Acc	Mod
26.9.3	7488	Check valve spd hi	rpm	INT16		0	0	CALCI	RW	VS

Setting of the speed at which the ramp starts for the “check valve” function.

Menu	PAR	Description	UM	Typo	FB BIT	Def	Min	Max	Acc	Mod
26.9.4	7490	Check valve time	s	UINT16		30	1	3600	RW	VS

Setting of the time it takes to pass from **Check valve spd hi** to **Check valve spd low**.

26.10 – PROCESS/PUMP CLEAN

The pump cleaning function is used to remove any residual solid matter that may have got caught in the rotor. During the cleaning cycle the pump is made to turn alternately forwards and backwards for a set number of turns.

Each single cleaning cycle consists of the following steps:

- The pump is stopped
- The pump is restarted to turn forwards and the speed is brought to the value set in **Clean fwd speed** in the time set in **Clean acc time**.
- The speed set in **Clean fwd speed** is then maintained for the time set in **Clean fwd time**.
- The pump is stopped in the time set in **Clean dec time**.
- The pump remains inactive for the time set in **Clean stop time**.
- The pump is restarted to turn backwards and the speed is brought to the value set in **Clean rev speed** in the time set in **Clean acc time**.
- The speed set in **Clean rev speed** is then maintained for the time set in **Clean rev time**.
- The pump is stopped in the time set in **Clean dec time**.
- The pump remains inactive for the time set in **Clean stop time**.

This cleaning mode cycle is repeated for the number of times set in **Clean num cycles**.

If **Clean fwd time** = 0, the entire forward rotation phase is bypassed (including the relative acceleration and deceleration).

If **Clean rev time** = 0, the entire backward rotation phase is bypassed (including the relative acceleration and deceleration).

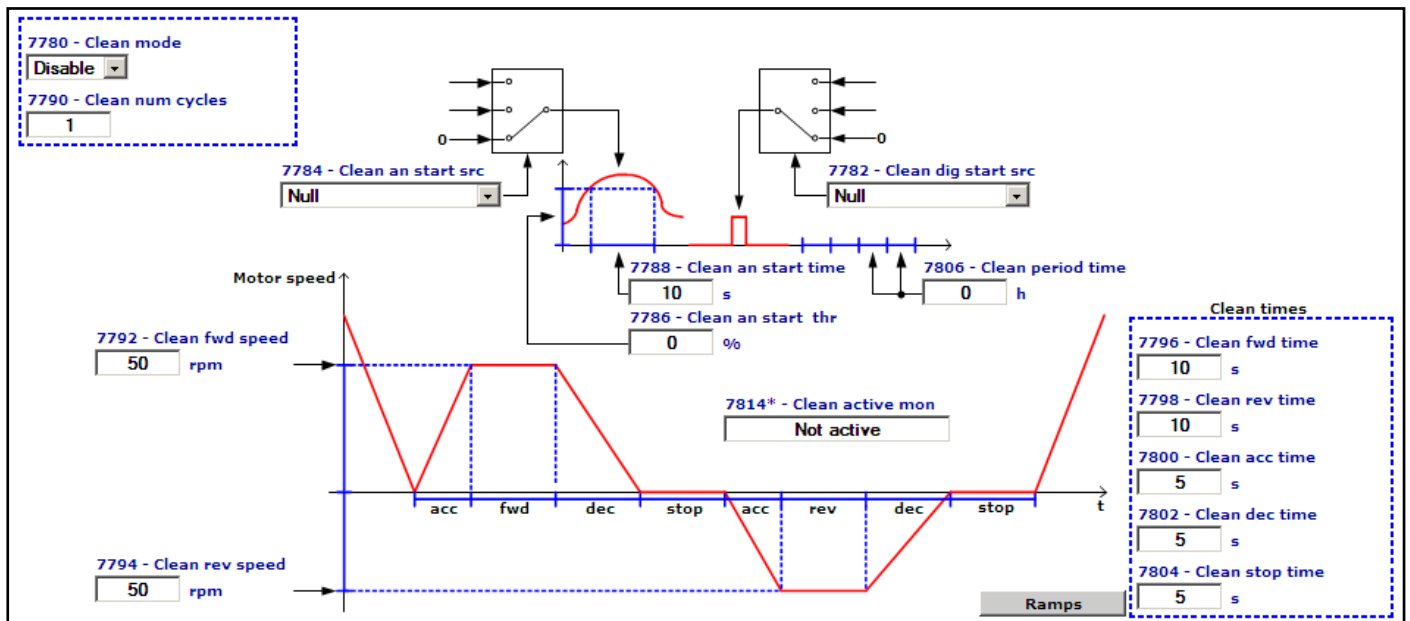

Cleaning cycle startup

There are several conditions that start a cleaning cycle sequence:

- At startup: a cleaning cycle is run each time the pump is started.
- Timed: cleaning is started periodically after a programmable length of time.
- External event: cleaning starts if an external digital signal is enabled.
- Analog measurement: cleaning is started if an analog value exceeds a threshold for a given time.

All the above conditions are independent and can be programmed separately. In case of timed startup, the time counter is reset if a cleaning cycle is started during the interval between one cycle and the next due to another source (startup, external event, analog measurement).

Cleaning alarms

If cleaning cycles are performed too frequently, there may be a problem with the pump that requires the attention of an operator.

In that case a specific alarm is generated. Only cleaning cycles that start following an external event (digital signal) or analog measurement are considered for this alarm.

Menu	PAR	Description	UM	Typo	FB BIT	Def	Min	Max	Acc	Mod
26.10.1	7780	Clean mode		ENUM		Disable	0	2	RW	VS

Setting of the pump cleaning mode.

- 0 Disable
- 1 On start
- 2 Normal

Set to **0** to disable pump cleaning mode.

Set to **1** to enable pump cleaning, which is performed at pump startup.

Set to **2** to enable pump cleaning, which is not performed at pump startup.

Menu	PAR	Description	UM	Typo	FB BIT	Def	Min	Max	Acc	Mod
26.10.2	7782	Clean dig start src		LINK	16BIT	6000	0	16384	RW	VS

Selection of the origin (source) of the digital signal to start cleaning due to an external event. The signal used for this function can be set from among those available in the "**L_DIGSEL2**" selection list.

Menu	PAR	Description	UM	Typo	FB BIT	Def	Min	Max	Acc	Mod
26.10.3	7784	Clean an start src		LINK	16BIT	6000	0	16384	RW	VS

Selection of the origin (source) of the analog signal to start cleaning due to an analog threshold. The signal used for this function can be set from among those available in the "**L_ANOUT**" selection list.

Menu	PAR	Description	UM	Typo	FB BIT	Def	Min	Max	Acc	Mod
26.10.4	7786	Clean an start thr	perc	INT16		0	0	100	RW	VS

Setting of the analog threshold above which the pump cleaning cycle starts.

Menu	PAR	Description	UM	Typo	FB BIT	Def	Min	Max	Acc	Mod
26.10.5	7788	Clean an start time	s	UINT16		10	0	500	RW	VS

Setting of the time after which, if the analog signal remains above the threshold set in parameter **7786 Clean an start thr**, the pump cleaning cycle starts.

Menu	PAR	Description	UM	Typo	FB BIT	Def	Min	Max	Acc	Mod
26.10.6	7790	Clean num cycles		UINT16		1	1	100	RW	VS

Setting of the number of operating cycles in both directions of rotation of the motor after which a pump cleaning cycle is to be performed.

Menu	PAR	Description	UM	Typo	FB BIT	Def	Min	Max	Acc	Mod
26.10.7	7792	Clean fwd speed	rpm	INT16		50	0	CALCI	RW	VS

Setting of the speed reference value for the normal direction of rotation during the pump cleaning function.

Menu	PAR	Description	UM	Typo	FB BIT	Def	Min	Max	Acc	Mod
26.10.8	7794	Clean rev speed	rpm	INT16		50	0	CALCI	RW	VS

Setting of the speed reference value for the reverse direction of rotation during the pump cleaning function.

Menu	PAR	Description	UM	Typo	FB BIT	Def	Min	Max	Acc	Mod
26.10.9	7796	Clean fwd time	s	UINT16		10	0	1000	RW	VS
Setting of the duration of cleaning in the normal direction of rotation during the pump cleaning function, calculated from when the speed is reached.										
26.10.10	7798	Clean rev time	s	UINT16		10	0	1000	RW	VS
Setting of the duration of cleaning in the reverse direction of rotation during the pump cleaning function, calculated from when the speed is reached.										
26.10.11	7800	Clean acc time	s	UINT16		5	1	1000	RW	VS
Setting of the time within which the motor must reach the speed of rotation during the pump cleaning procedure.										
26.10.12	7802	Clean dec time	s	UINT16 16BIT		5	1	1000	R	VS
Setting of the time within which the motor must reach zero speed during the pump cleaning procedure.										
26.10.13	7804	Clean stop time	s	UINT16		5	0	1000	RW	VS
Setting of the stop time between rotations and at the end of the pump cleaning cycle.										
26.10.14	7806	Clean period time	h	UINT16		0	0	30000	RW	VS
Setting of the interval of time between two cleaning cycles (if the function is not controlled by digital input or analog signal).										
26.10.15	7778	Clean period mon	h	UINT16		0	0	0	R	VS
This parameter shows the time elapsed from the last cleaning of the activated pump from the timed mode (parameter setting 7806 > 0). When the displayed time exceeds the scheduled period (par 7806), a pump cleaning cycle is started. When the pump cleaning is controlled by a digital inlet or an analogic reference, at its end this parameter is reset and the elapsed time count starts again.										
26.10.16	7814	Clean active mon		ENUM		Not active	0	4	R	VS
This parameter can be used to know whether a pump cleaning cycle is in progress and which command generated it.										
<ul style="list-style-type: none"> 0 Not active 1 On start 2 Digital src 3 Analog src 4 Period src 										

26.11 – PROCESS/LOW POWER CALC

These parameters are used to set the minimum power curve. Below this range the flow capacity is considered zero.

This function is used to manage the **No flow** and **Dry pump** alarms.

The power at 2 different speeds, with delivery valve closed, must be acquired to calculate the curve.

The system's static pressure speed is normally equal to the design pressure speed. Measurements must be performed with the delivery valve closed.

There is a parameter that adds an offset to correct the curve according to the specific operating conditions.

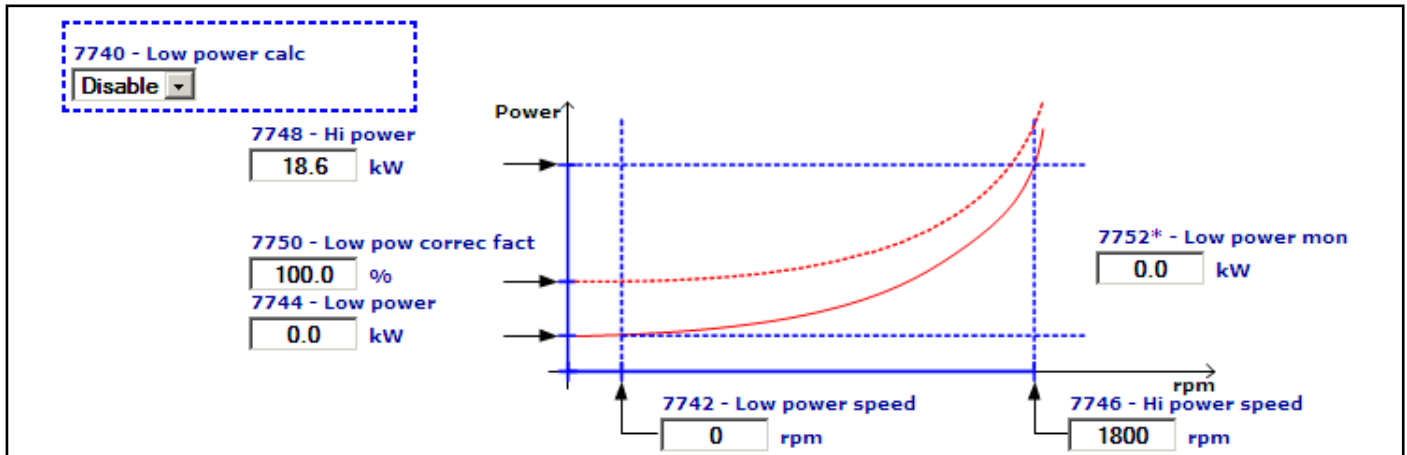

Menu	PAR	Description	UM	Typo	FB BIT	Def	Min	Max	Acc	Mod
26.11.1	7740	Low power calc		ENUM		Disable	0	1	RW	VS

Setting of the low power calculation mode.

0 Disable

1 Enable

Set to **0** to disable minimum power calculation.

Set to **1** to enable minimum power calculation.

Menu	PAR	Description	UM	Typo	FB BIT	Def	Min	Max	Acc	Mod
26.11.2	7742	Low power speed	rpm	INT16		0	0	CALCI	RW	VS

Setting of the speed at the setpoint.

Menu	PAR	Description	UM	Typo	FB BIT	Def	Min	Max	Acc	Mod
26.11.3	7744	Low power	kW	FLOAT		0.0	0.0	CALCF	RW	VS

Power measured at the setpoint set in parameter **7742 Low power speed**.

Menu	PAR	Description	UM	Typo	FB BIT	Def	Min	Max	Acc	Mod
26.11.4	7746	Hi power speed	rpm	INT16		0	0	CALCI	RW	VS

Setting of the speed at the second setpoint.

Menu	PAR	Description	UM	Typo	FB BIT	Def	Min	Max	Acc	Mod
26.11.5	7748	Hi power	kW	FLOAT		0.0	0.0	CALCF	RW	VS

Power measured at the setpoint set in parameter **7746 Hi power speed**.

Menu	PAR	Description	UM	Typo	FB BIT	Def	Min	Max	Acc	Mod
26.11.6	7750	Low pow correc fact	perc	FLOAT		100.0	0.0	200.0	RW	VS

Setting of the curve offset. This parameter can be used to correct the curve according to actual system conditions.

Menu	PAR	Description	UM	Typo	FB BIT	Def	Min	Max	Acc	Mod
26.11.7	7752	Low power mon	kW	FLOAT		0.0	0.0	0.0	R	VS

The power calculated for the current speed is displayed. This value is used as the threshold for the **No flow** and **Dry pump** alarms

26.12 – PROCESS/FIRE FUNCTION

When the fire function is enabled the motor is brought to a previously defined speed and the drive ignores any alarms that are triggered. Any disable and stop signals are still considered when the fire function is enabled.

Bypass function

If the bypass function is enabled, when an alarm is triggered during a fire condition, it is only ignored for a previously defined time. After that time a digital output is activated and the alarm is enabled. The digital output is normally connected to a power contactor that bypasses the drive and connects the motor directly to the mains.

Menu	PAR	Description	UM	Typo	FB BIT	Def	Min	Max	Acc	Mod
26.12.1	7840	Fire function		ENUM		Disable	0	3	RW	VS

Setting of the fire function.

- 0 Disable
- 1 Forward
- 2 Reverse
- 3 Forward bypass

Set to **0** to disable the fire function.

Set to **1** to enable the fire function. The motor turns in the normal direction of operation.

Set to **2** to enable the fire function. The motor turns in the direction opposite to the normal direction of operation.

Set to **3** to enable the fire function. The motor turns in the normal direction of operation and the bypass function is enabled.

Menu	PAR	Description	UM	Typo	FB BIT	Def	Min	Max	Acc	Mod
26.12.2	7842	Fire command src		LINK	16BIT	6000	0	16384	RW	VS

Selection of the origin (source) of the digital signal that activates the fire function. The signal used for this function can be set from among those available in the “L_DIGSEL2” selection list.

Menu	PAR	Description	UM	Typo	FB BIT	Def	Min	Max	Acc	Mod
26.12.3	7844	Fire speed	rpm	FLOAT		0	0	CALCI	RW	VS

Setting of the speed that must be maintained when the fire function is active.

Menu	PAR	Description	UM	Typo	FB BIT	Def	Min	Max	Acc	Mod
26.12.4	7846	Fire bypass delay	s	INT16		0.0	0.0	3600	RW	VS

Setting of the delay before the bypass function is activated.

Menu	PAR	Description	UM	Typo	FB BIT	Def	Min	Max	Acc	Mod
26.12.5	7848	Fire bypass mon		BIT	16BIT	0	0	1	R	VS

The status of the bypass function is displayed. It must be connected to the output that controls the bypass power contactor.

Menu	PAR	Description	UM	Typo	FB BIT	Def	Min	Max	Acc	Mod
26.12.6	7850	Fire out mon		BIT	16BIT	0	0	1	R	VS

The status of the fire function is displayed. If this parameter is set to 1, the fire function is active.

26.13 – PROCESS/TIMERS

Timers are used to activate timed functions that may be programmed weekly or daily.

Each timer supplies an output monitor that can be used as a digital source.

They are generally used to program automatic motor startup or to change setpoints on a daily or weekly basis.

There are 2 sets of parameters for programming timers: time intervals (TI) and timers.

Time intervals are defined by the day of the week, hour and minute of startup and day of the week, hour and minute of switching off.

One or more time intervals can be associated with each timer and when the current time is within at least one of the associated time intervals, the timer is activated.

The timer can be associated with the weekly time interval, or just with the daily part.

The weekly timer is activated every week from the day hour minute of startup to the day hour minute of switching off.

The daily timer is activated every day from the hour minute of startup to the hour minute of switching off.

Timers are usually activated within a programmed interval of time, but there is also a parameter that can be used to activate them outside that interval.

A maximum of 4 time intervals can be set.

Up to 4 timers can be programmed.

The same time interval may be associated with more than one timer.

Menu	PAR	Description	UM	Typo	FB BIT	Def	Min	Max	Acc	Mod	
26.13.1	7860	TI 1 week day start		ENUM		Sunday	0	6	RW	VS	
		Setting of the day of the week on which TI 1 must start.									
		0	Sunday								
		1	Monday								
		2	Tuesday								
		3	Wednesday								
		4	Thursday								
		5	Friday								
		6	Saturday								

Menu	PAR	Description	UM	Typo	FB BIT	Def	Min	Max	Acc	Mod
26.13.2	7862	TI 1 hour start	h	UINT16		0	0	23	RW	VS
		Setting of the hour in which TI 1 must start.								

Menu	PAR	Description	UM	Typo	FB BIT	Def	Min	Max	Acc	Mod
26.13.3	7864	TI 1 minute start	min	UINT16		0	0	59	RW	VS
		Setting of the minute in which TI 1 must start.								

Menu	PAR	Description	UM	Typo	FB BIT	Def	Min	Max	Acc	Mod	
26.13.4	7866	TI 1 week day stop		ENUM		Sunday	0	6	RW	VS	
		Setting of the day of the week on which TI 1 must stop.									
		0	Sunday								
		1	Monday								
		2	Tuesday								
		3	Wednesday								
		4	Thursday								

- 5 Friday
- 6 Saturday

Menu	PAR	Description	UM	Typo	FB BIT	Def	Min	Max	Acc	Mod
26.13.5	7868	TI 1 hour stop	h	UINT16		0	0	24	RW	VS

Setting of the hour in which TI 1 must stop.

Menu	PAR	Description	UM	Typo	FB BIT	Def	Min	Max	Acc	Mod
26.13.6	7870	TI 1 minute stop	min	UINT16		0	0	59	RW	VS

Setting of the minute in which TI 1 must stop.

Menu	PAR	Description	UM	Typo	FB BIT	Def	Min	Max	Acc	Mod
26.13.7	7872	TI 2 week day start		ENUM		Sunday	0	6	RW	VS

Setting of the day of the week on which TI 2 must start.

- 0 Sunday
- 1 Monday
- 2 Tuesday
- 3 Wednesday
- 4 Thursday
- 5 Friday
- 6 Saturday

Menu	PAR	Description	UM	Typo	FB BIT	Def	Min	Max	Acc	Mod
26.13.8	7874	TI 2 hour start	h	UINT16		0	0	23	RW	VS

Setting of the hour in which TI 2 must start.

Menu	PAR	Description	UM	Typo	FB BIT	Def	Min	Max	Acc	Mod
26.13.9	7876	TI 2 minute start	min	UINT16		0	0	59	RW	VS

Setting of the minute in which TI 2 must start.

Menu	PAR	Description	UM	Typo	FB BIT	Def	Min	Max	Acc	Mod
26.13.10	7878	TI 2 week day stop		ENUM		Sunday	0	6	RW	VS

Setting of the day of the week on which TI 2 must stop.

- 0 Sunday
- 1 Monday
- 2 Tuesday
- 3 Wednesday
- 4 Thursday
- 5 Friday
- 6 Saturday

Menu	PAR	Description	UM	Typo	FB BIT	Def	Min	Max	Acc	Mod
26.13.11	7880	TI 2 hour stop	h	UINT16		0	0	24	RW	VS

Setting of the hour in which TI 2 must stop.

Menu	PAR	Description	UM	Typo	FB BIT	Def	Min	Max	Acc	Mod
26.13.12	7882	TI 2 minute stop	min	UINT16		0	0	59	RW	VS

Setting of the minute in which TI 2 must stop.

Menu	PAR	Description	UM	Typo	FB BIT	Def	Min	Max	Acc	Mod
26.13.13 7884		TI 3 week day start		ENUM		Sunday	0	6	RW	VS
Setting of the day of the week on which TI 3 must start.										
0 Sunday										
1 Monday										
2 Tuesday										
3 Wednesday										
4 Thursday										
5 Friday										
6 Saturday										

Menu	PAR	Description	UM	Typo	FB BIT	Def	Min	Max	Acc	Mod
26.13.14 7886		TI 3 hour start	h	UINT16		0	0	23	RW	VS
Setting of the hour in which TI 3 must start.										

Menu	PAR	Description	UM	Typo	FB BIT	Def	Min	Max	Acc	Mod
26.13.15 7888		TI 3 minute start	min	UINT16		0	0	59	RW	VS
Setting of the minute in which TI 3 must start.										

Menu	PAR	Description	UM	Typo	FB BIT	Def	Min	Max	Acc	Mod
26.13.16 7890		TI 3 week day stop		ENUM		Sunday	0	6	RW	VS
Setting of the day of the week on which TI 3 must stop.										
0 Sunday										
1 Monday										
2 Tuesday										
3 Wednesday										
4 Thursday										
5 Friday										
6 Saturday										

Menu	PAR	Description	UM	Typo	FB BIT	Def	Min	Max	Acc	Mod
26.13.17 7892		TI 3 hour stop	h	UINT16		0	0	24	RW	VS
Setting of the hour in which TI 3 must stop.										

Menu	PAR	Description	UM	Typo	FB BIT	Def	Min	Max	Acc	Mod
26.13.18 7894		TI 3 minute stop	min	UINT16		0	0	59	RW	VS
Setting of the minute in which TI 3 must stop.										

Menu	PAR	Description	UM	Typo	FB BIT	Def	Min	Max	Acc	Mod
26.13.19 7896		TI 4 week day start		ENUM		Sunday	0	6	RW	VS
Setting of the day of the week on which TI 4 must start.										
0 Sunday										
1 Monday										
2 Tuesday										
3 Wednesday										
4 Thursday										
5 Friday										
6 Saturday										

Menu	PAR	Description	UM	Typo	FB BIT	Def	Min	Max	Acc	Mod
26.13.20	7898	TI 4 hour start	h	UINT16		0	0	23	RW	VS
Setting of the hour in which TI 4 must start.										
26.13.21	7900	TI 4 minute start	min	UINT16		0	0	59	RW	VS
Setting of the minute in which TI 4 must start.										
26.13.22	7902	TI 4 week day stop		ENUM		Sunday	0	6	RW	VS
Setting of the day of the week on which TI 4 must stop.										
<ul style="list-style-type: none"> 0 Sunday 1 Monday 2 Tuesday 3 Wednesday 4 Thursday 5 Friday 6 Saturday 										
26.13.23	7904	TI 4 hour stop	h	UINT16		0	0	24	RW	VS
Setting of the hour in which TI 4 must stop.										
26.13.24	7906	TI 4 minute stop	min	UINT16		0	0	59	RW	VS
Setting of the minute in which TI 4 must stop.										
26.13.25	7908	Timer1 selection		UINT16		0	0	2222	RW	VS
Selection of timer 1:										
The position of each digit selects a time interval; the units select interval TI1, thousands interval TI4. the meaning of the digits is as follows:										
<ul style="list-style-type: none"> 0 = TI not selected 1 = daily TI selected 2 = weekly TI selected 										
Examples:										
<ul style="list-style-type: none"> 102 - weekly TI1 and daily TI3 selected 1 - daily TI selected 2010 - daily TI2 and weekly TI4 selected 										
26.13.26	7910	Timer1 active status		BIT		1	0	1	RW	VS
Selection of timer 1 activation status:										
If set to 0 the timer is activated outside the time interval										
If set to 1 the timer is activated within the time interval										
26.13.27	7912	Timer1 status mon		BIT		1	0	1	R	VS
The timer 1 status is displayed: if set to 1, timer 1 is active. This timer 1 status may be connected to digital sources.										

Menu	PAR	Description	UM	Typo	FB BIT	Def	Min	Max	Acc	Mod
26.13.28	7914	Timer2 selection		U	INT16	0	0	2222	RW	VS

Selection of timer 2:

The position of each digit selects a time interval; the units select interval T11, thousands interval T14. the meaning of the digits is as follows:

- 0 = TI not selected
- 1 = daily TI selected
- 2 = weekly TI selected

Examples:

- 102 - weekly T11 and daily T13 selected
- 1 - daily TI selected
- 2010 - daily T12 and weekly T14 selected

Menu	PAR	Description	UM	Typo	FB BIT	Def	Min	Max	Acc	Mod
26.13.29	7916	Timer2 active status			BIT	1	0	1	RW	VS

Selection of timer 2 activation status:

If set to **0** the timer is activated outside the time interval

If set to **1** the timer is activated within the time interval

Menu	PAR	Description	UM	Typo	FB BIT	Def	Min	Max	Acc	Mod
26.13.30	7918	Timer2 status mon			BIT	1	0	1	R	VS

The timer 2 status is displayed: if set to 1, timer 2 is active. This timer 2 status may be connected to digital sources.

Menu	PAR	Description	UM	Typo	FB BIT	Def	Min	Max	Acc	Mod
26.13.31	7920	Timer3 selection		U	INT16	0	0	2222	RW	VS

Selection of timer 3:

The position of each digit selects a time interval; the units select interval T11, thousands interval T14. the meaning of the digits is as follows:

- 0 = TI not selected
- 1 = daily TI selected
- 2 = weekly TI selected

Examples:

- 102 - weekly T11 and daily T13 selected
- 1 - daily TI selected
- 2010 - daily T12 and weekly T14 selected

Menu	PAR	Description	UM	Typo	FB BIT	Def	Min	Max	Acc	Mod
26.13.32	7922	Timer3 active status			BIT	1	0	1	RW	VS

Selection of timer 3 activation status:

If set to **0** the timer is activated outside the time interval

If set to **1** the timer is activated within the time interval

Menu	PAR	Description	UM	Typo	FB BIT	Def	Min	Max	Acc	Mod
26.13.33	7924	Timer3 status mon			BIT	1	0	1	R	VS

The timer 3 status is displayed: if set to 1, timer 3 is active. This timer 3 status may be connected to digital sources.

Menu	PAR	Description	UM	Typo	FB BIT	Def	Min	Max	Acc	Mod
26.13.34	7926	Timer4 selection		U	INT16	0	0	2222	RW	VS

Selection of timer 4:

The position of each digit selects a time interval; the units select interval TI1, thousands interval TI4. the meaning of the digits is as follows:

0 = TI not selected

1 = daily TI selected

2 = weekly TI selected

Examples:

102 - weekly TI1 and daily TI3 selected

1 - daily TI selected

2010 - daily TI2 and weekly TI4 selected

Menu	PAR	Description	UM	Typo	FB BIT	Def	Min	Max	Acc	Mod
26.13.35	7928	Timer4 active status		BIT		1	0	1	RW	VS

Selection of timer 4 activation status:

If set to **0** the timer is activated outside the time interval

If set to **1** the timer is activated within the time interval

Menu	PAR	Description	UM	Typo	FB BIT	Def	Min	Max	Acc	Mod
26.13.36	7930	Timer4 status mon		BIT		1	0	1	R	VS

The timer 4 status is displayed: if set to 1, timer 4 is active. This timer 4 status may be connected to digital sources.

26.14 – PROCESS/MULTI PUMP

Controlling several pumps connected in parallel: 1 master and from 1 to 8 followers. Connect the follower pumps to the relay card outputs. There are 2 operating modes:

Standard: where the master pump is fixed and always controlled by the inverter, the follower pumps always operate at fixed speed and are controlled by the relays. The master pump maintains the reference, the fixed pumps are activated (or deactivated) in sequence, when the master pump reaches the regulation limits. With this configuration 1 master pump and 8 follower pumps can be controlled.

Via the optional card EXP-IO-D5R8-ADV shown below, you can enable up to 4 pumps (4 digital inputs available), to enable the other four pumps can be used in any digital inputs of the drive or can be set to "One" the parameter **Pump X intlock src** corresponding.

The connection diagram is as follows:

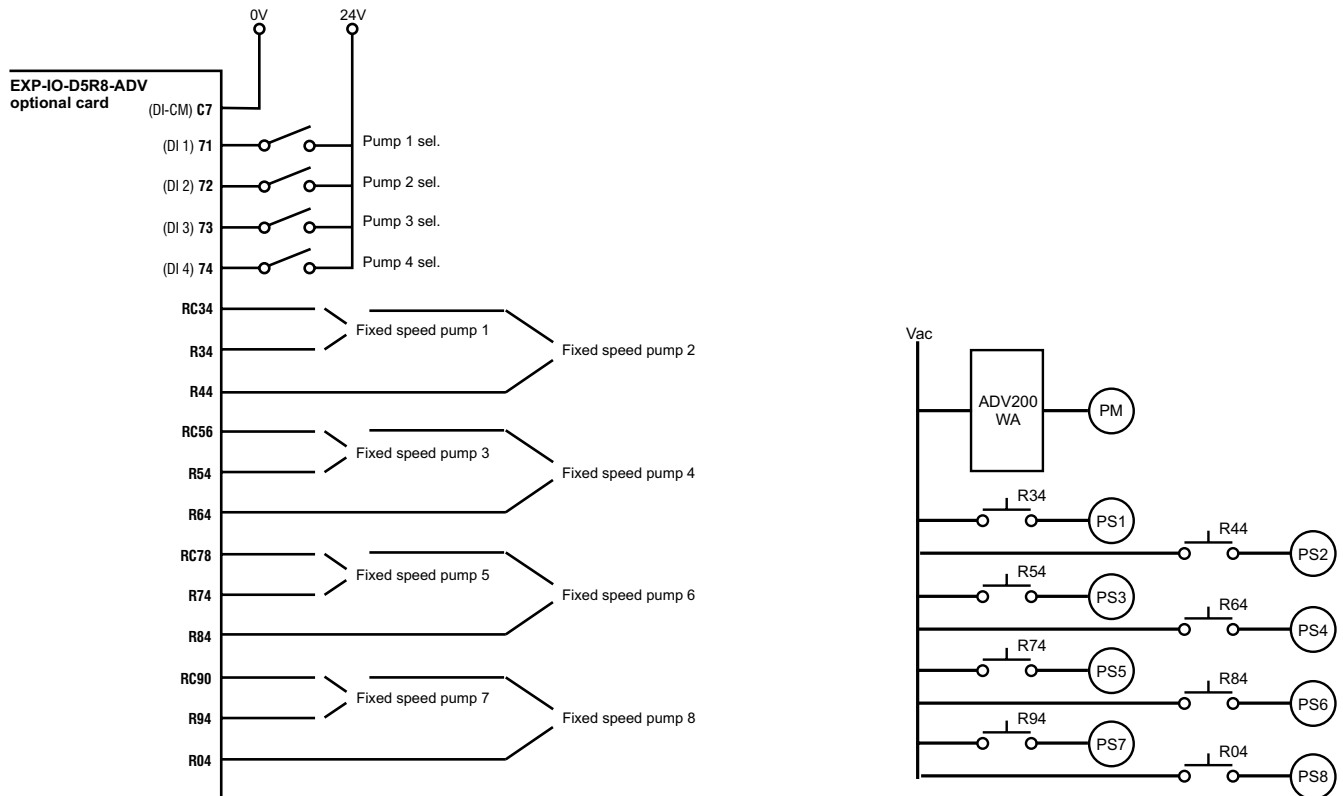

Program the digital inputs in menu **26.14 – PROCESS/MULTI PUMP** as follows:

- 7130 **Pump 1 intlock src** = Digital input 1X mon
- 7132 **Pump 2 intlock src** = Digital input 2X mon
- 7134 **Pump 3 intlock src** = Digital input 3X mon
- 7136 **Pump 4 intlock src** = Digital input 4X mon
- 7138 **Pump 5 intlock src** = Digital input 5X mon
- 7140 **Pump 6 intlock src** = Digital input 6X mon
- 7142 **Pump 7 intlock src** = Digital input 7X mon
- 7144 **Pump 8 intlock src** = Digital input 8X mon

Program fixed-speed follower pump control in menu **13 - DIGITAL OUTPUTS** as follows:

- 1410 **Dig output 1X src** = Pump 1 out mon
- 1412 **Dig output 2X src** = Pump 2 out mon
- 1414 **Dig output 3X src** = Pump 3 out mon
- 1416 **Dig output 4X src** = Pump 4 out mon
- 1418 **Dig output 5X src** = Pump 5 out mon
- 1420 **Dig output 6X src** = Pump 6 out mon
- 1422 **Dig output 7X src** = Pump 7 out mon
- 1424 **Dig output 8X src** = Pump 8 out mon

Master pump rotation: where the master pump is not always the same one, but each of the pumps in turn. With this configuration the pumps **must be the same** and a maximum number of 4 pumps can be used. In that case there are 2 relays per pump.

Advantages:

- wear is also shared by the master pump.
- the master pump may also be placed “out of service”.

The connection diagram is as follows:

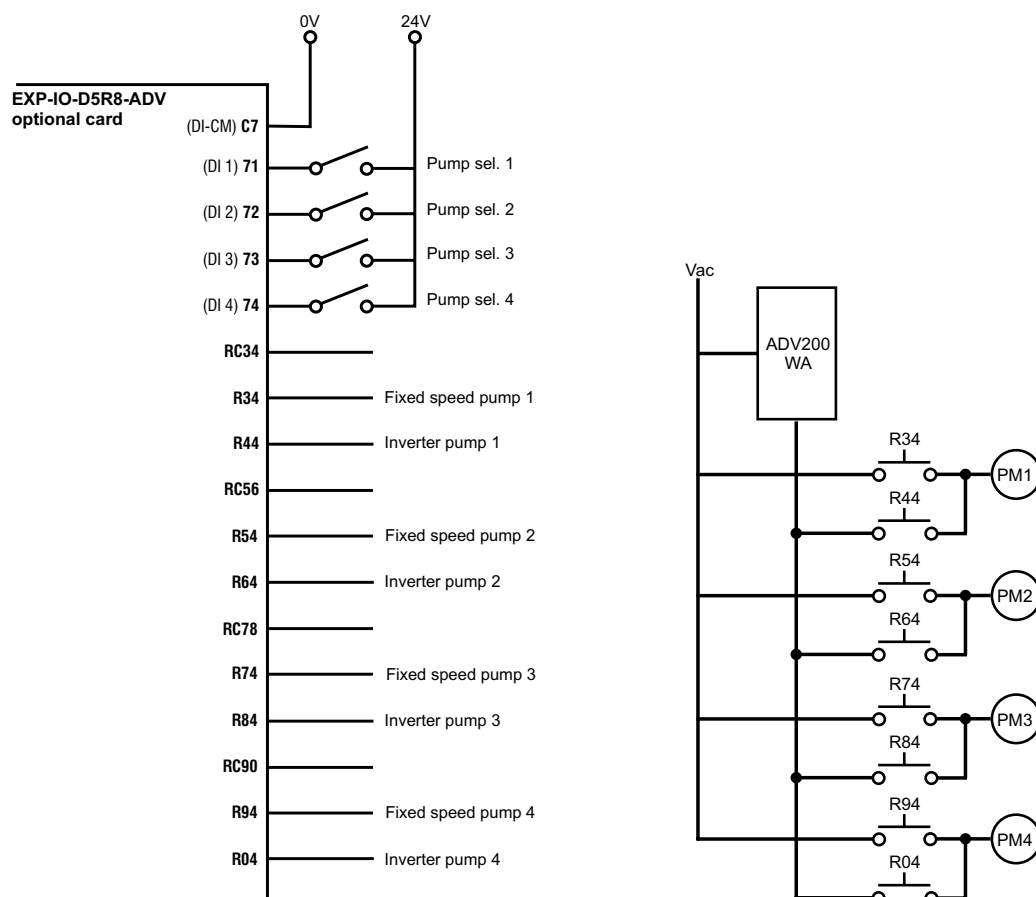

Program the digital inputs in menu **26.14 – PROCESS/MULTI PUMP** as follows:

- 7130 **Pump 1 intlock src** = Digital input 1X mon
- 7132 **Pump 2 intlock src** = Digital input 2X mon
- 7134 **Pump 3 intlock src** = Digital input 3X mon
- 7136 **Pump 4 intlock src** = Digital input 4X mon

Program fixed-speed follower pump control in menu **13 - DIGITAL OUTPUTS** as follows:

- 1410 **Dig output 1X src** = Pump 1 out mon
- 1412 **Dig output 2X src** = Pump 2 out mon
- 1414 **Dig output 3X src** = Pump 3 out mon
- 1416 **Dig output 4X src** = Pump 4 out mon
- 1418 **Dig output 5X src** = Pump 1 lead mon
- 1420 **Dig output 6X src** = Pump 2 lead mon
- 1422 **Dig output 7X src** = Pump 3 lead mon
- 1424 **Dig output 8X src** = Pump 4 lead mon

When a “Pump X lead mon” output is active for a master pump, the equivalent “Pump X out mon” is deactivated, to avoid any damage to the inverter.

Follower pump activation and deactivation logic

The **Staging bandwidth** parameter is used to define a reference bandwidth.

- Follower pump startup:

When the feedback falls below the value set in **Staging bandwidth** for longer than the time set in **Staging delay**, a new follower pump is activated.

When a follower pump is activated, the master pump is at maximum speed and there is a possibility of overpressure occurring during the transition, when a new follower pump is activated but the PID has still not lowered the speed of the master pump.

To avoid such overpressure, the speed of the master pump is lowered to that set in **Staging speed** before starting the follower pump.

- Switching the follower pump of:

When the feedback rises above the value set in **Staging bandwidth** for longer than the time set in **Staging delay**, one of the follower pumps must be switched off.

At this moment the master pump is running at minimum speed so that, when a follower pump is switched off, the pressure could fall too low until the PID restores the speed of the master pump. To reduce this effect, the **Staging speed** parameter can be used to set a higher master pump speed before switching one of the follower pumps off.

Override bandwidth

Switching to another follower pump could result in temporary changes in pressure, causing other pumps to be activated or deactivated. To avoid this, it is possible to override the bandwidth for a time that can be set in parameters **Override time** and **Override bandwidth**.

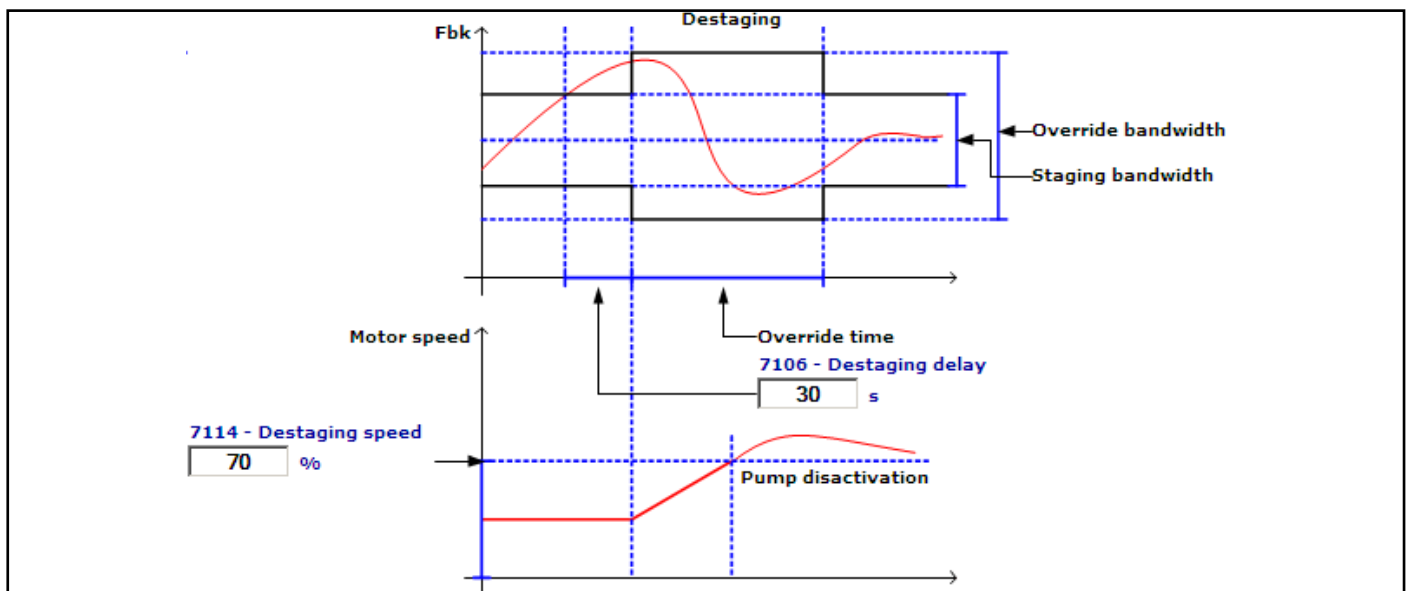

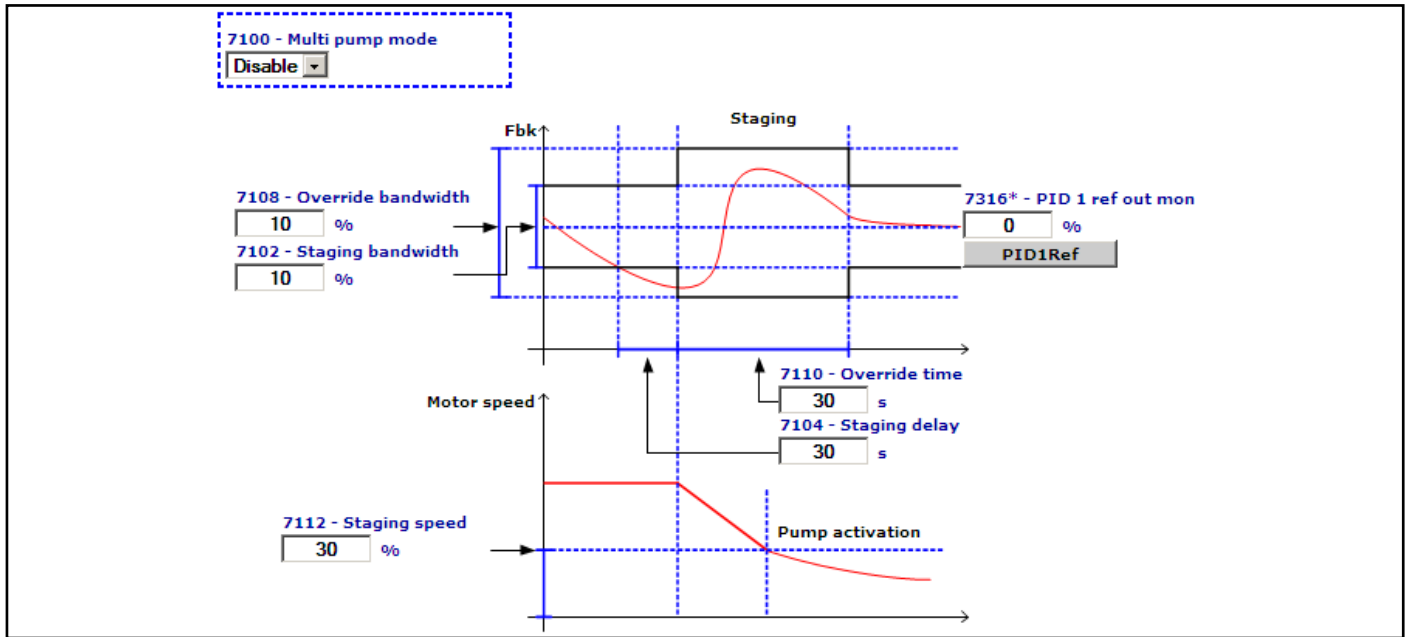

Follower pump cycle

If the **Follower pump** function is activated, the follower pumps are used in rotation to ensure equal wear. The sequence is as follows: when a pump has to be activated, the one that has been used for less time is activated and when one has to be deactivated, the one that has been used for the most time is switched off.

Alternating mode

In alternating mode the master pump, which is the one controlled by the drive, is used in rotation along with all the other pumps. Rotation may be timed or via digital control.

Menu	PAR	Description	UM	Typo	FB BIT	Def	Min	Max	Acc	Mod
26.14.1	7100	Multi pump mode		ENUM		Disable	0	1	RW	VS

Enabling of multiple pump mode

0 Disable

1 Enable

Set to **0** to disable the multiple pump function.

Set to **1** to enable the multiple pump function.

Menu	PAR	Description	UM	Typo	FB BIT	Def	Min	Max	Acc	Mod
26.14.2	7102	Staging bandwidth	perc	INT16		10	0	100	RW	VS

Setting of the bandwidth. If the feedback remains below the value set in this parameter for the time set in **7104 Staging delay**, a new fixed-speed pump is activated. If the feedback remains above the value set in this parameter for the time set in **7106 Destaging delay**, a fixed-speed pump is deactivated.

Menu	PAR	Description	UM	Typo	FB BIT	Def	Min	Max	Acc	Mod
26.14.3	7104	Staging delay	s	UINT16		30	1	3600	RW	VS

Setting of the delay before activating a follower pump when the feedback signal remains below the bandwidth set in parameter **7102 Staging bandwidth**.

Menu	PAR	Description	UM	Typo	FB BIT	Def	Min	Max	Acc	Mod
26.14.4	7106	Destaging delay	s	UINT16		30	1	3600	RW	VS

Setting of the delay before deactivating a follower pump when the feedback signal remains above the bandwidth set in parameter **7102 Staging bandwidth**.

Menu	PAR	Description	UM	Typo	FB BIT	Def	Min	Max	Acc	Mod
26.14.5	7108	Override bandwidth	perc	INT16		10	0	100	RW	VS

Setting of the bandwidth of the follower pump used after switching a follower pump, to reduce the pressure

transient effect. This parameter must have a value that is greater than that set in parameter **7102 Staging bandwidth**.

Menu	PAR	Description	UM	Typo	FB BIT	Def	Min	Max	Acc	Mod
26.14.6	7110	Override time	s	U	INT16	30	1	3600	RW	VS

Setting of the duration of bandwidth override after switching.

Menu	PAR	Description	UM	Typo	FB BIT	Def	Min	Max	Acc	Mod
26.14.7	7112	Staging speed	perc	I	INT16	30	0	100	RW	VS

Setting of the speed of connection of a follower pump. To avoid jumps in pressure, during the connection of a follower pump, the motor speed is changed by the value set in this parameter. The pump is connected when this speed is reached.

Menu	PAR	Description	UM	Typo	FB BIT	Def	Min	Max	Acc	Mod
26.14.8	7114	Destaging speed	perc	I	INT16	70	0	100	RW	VS

Setting of the speed of disconnection of a follower pump. To avoid jumps in pressure, during the disconnection of a follower pump, the motor speed is changed by the value set in this parameter. The pump is disconnected when this speed is reached.

Menu	PAR	Description	UM	Typo	FB BIT	Def	Min	Max	Acc	Mod
26.14.9	7116	Destage time	s	U	INT16	0	1	3600	RW	VS

Setting of the time after which, if the speed-controlled pump is at minimum speed, and the feedback signal is within the bandwidth, a pump is deactivated at the fixed speed. The purpose of this function is to prevent the drive working too long in a limit zone where feedback cannot be controlled. This improves system efficiency.

Menu	PAR	Description	UM	Typo	FB BIT	Def	Min	Max	Acc	Mod
26.14.10	7118	Pumps cycle		B	BIT	0	0	1	RWZ	VS

Enabling of the pump cycle function. If this parameter is set to 1, the auxiliary pumps are activated in rotation rather than following a constant order. The pump that has been used the least number of hours is activated first and the one that has been used for the most hours is the first to be switched off. The hours of operation are calculated from the last startup, thus if the drive is disconnected the sequence is re-initialised. This function only applies to fixed-speed follower pumps.

Menu	PAR	Description	UM	Typo	FB BIT	Def	Min	Max	Acc	Mod
26.14.11	7120	Alternation mode		E	ENUM	Disable	0	1	RWZ	VS

Enabling of speed-controlled pump alternating mode
0 Disable
1 Enable

Set to **0** to disable the master pump alternating function.
Set to **1** to enable the master pump alternating function.

Menu	PAR	Description	UM	Typo	FB BIT	Def	Min	Max	Acc	Mod
26.14.12	7122	Alternation time	min	U	INT16	0	0	999	RW	VS

Setting of the alternating time interval. This parameter defines the maximum continuous operating time of the speed-controlled pump.

Menu	PAR	Description	UM	Typo	FB BIT	Def	Min	Max	Acc	Mod
26.14.13	7124	Alt actual time	h.min	U	INT16	1	0	9999999	RW	VS

The time since the last alternation of the speed-controlled pump is displayed.

Menu	PAR	Description	UM	Typo	FB BIT	Def	Min	Max	Acc	Mod	
26.14.14	7126	Altern ext event src		L	LINK	16BIT	6000	0	16384	RW	VS

Selection of the origin (source) of the digital signal that forces pump alternation with an external command. The signal used for this function can be set from among those available in the “**L_DIGSEL4**” selection list.

Menu	PAR	Description	UM	Typo	FB BIT	Def	Min	Max	Acc	Mod
26.14.15	7128	Altern restart delay	s	UINT16		30	1	3600	RW	VS

Setting of the delay after stopping the master pump before re-starting. After the alternation event the master pump is stopped and the follower pump relays are opened. This time must pass before restarting the pumps to be sure that those not controlled by the drive have also stopped

Menu	PAR	Description	UM	Typo	FB BIT	Def	Min	Max	Acc	Mod
26.14.16	7130	Pump 1 intlock src		LINK	16BIT	6000	0	16384	RW	VS
26.14.17	7130	Pump 2 intlock src		LINK	16BIT	6000	0	16384	RW	VS
26.14.18	7132	Pump 3 intlock src		LINK	16BIT	6000	0	16384	RW	VS
26.14.19	7134	Pump 4 intlock src		LINK	16BIT	6000	0	16384	RW	VS
26.14.20	7138	Pump 5 intlock src		LINK	16BIT	6000	0	16384	RW	VS
26.14.21	7140	Pump 6 intlock src		LINK	16BIT	6000	0	16384	RW	VS
26.14.22	7142	Pump 7 intlock src		LINK	16BIT	6000	0	16384	RW	VS
26.14.23	7144	Pump 8 intlock src		LINK	16BIT	6000	0	16384	RW	VS

Selection of the origin (source) of the digital signal that indicates the availability of pump X. The signal used for this function can be set from among those available in the “**L_DIGSEL4**” selection list.

Menu	PAR	Description	UM	Typo	FB BIT	Def	Min	Max	Acc	Mod
26.14.24	7150	Pump 1 out mon		BIT		1	0	1	R	VS
26.14.25	7152	Pump 2 out mon		BIT		1	0	1	R	VS
26.14.26	7154	Pump 3 out mon		BIT		1	0	1	R	VS
26.14.27	7156	Pump 4 out mon		BIT		1	0	1	R	VS
26.14.28	7158	Pump 5 out mon		BIT		1	0	1	R	VS
26.14.29	7160	Pump 5 out mon		BIT		1	0	1	R	VS
26.14.30	7162	Pump 7 out mon		BIT		1	0	1	R	VS
26.14.31	7164	Pump 8 out mon		BIT		1	0	1	R	VS

The status of follower pump X is displayed. If this parameter is set to 1, the pump may be controlled. This signal must be connected to the digital output that controls the fixed-speed pump X control relay.

Menu	PAR	Description	UM	Typo	FB BIT	Def	Min	Max	Acc	Mod
26.14.32	7170	Pump 1 lead mon		BIT		1	0	1	R	VS
26.14.33	7172	Pump 2 lead mon		BIT		1	0	1	R	VS
26.14.34	7174	Pump 3 lead mon		BIT		1	0	1	R	VS
26.14.35	7176	Pump 4 lead mon		BIT		1	0	1	R	VS
26.14.36	7178	Pump 5 lead mon		BIT		1	0	1	R	VS
26.14.37	7180	Pump 6 lead mon		BIT		1	0	1	R	VS
26.14.38	7182	Pump 7 lead mon		BIT		1	0	1	R	VS
26.14.39	7184	Pump 8 lead mon		BIT		1	0	1	R	VS

The status of master pump X is displayed. If this parameter is set to 1, the speed-controlled pump is connected and the output that controls the relay for connecting the pump directly to the supply mains is not allowed. This signal must be connected to the digital output that controls the pump X control relay.

27 - SOLAR PUMP

This drive makes the Solar Pump application available to the user (Application 1). It was developed for solar-powered pumping systems that use photovoltaic technology to convert sunlight into the electricity needed to power the extraction and/or distribution pump.

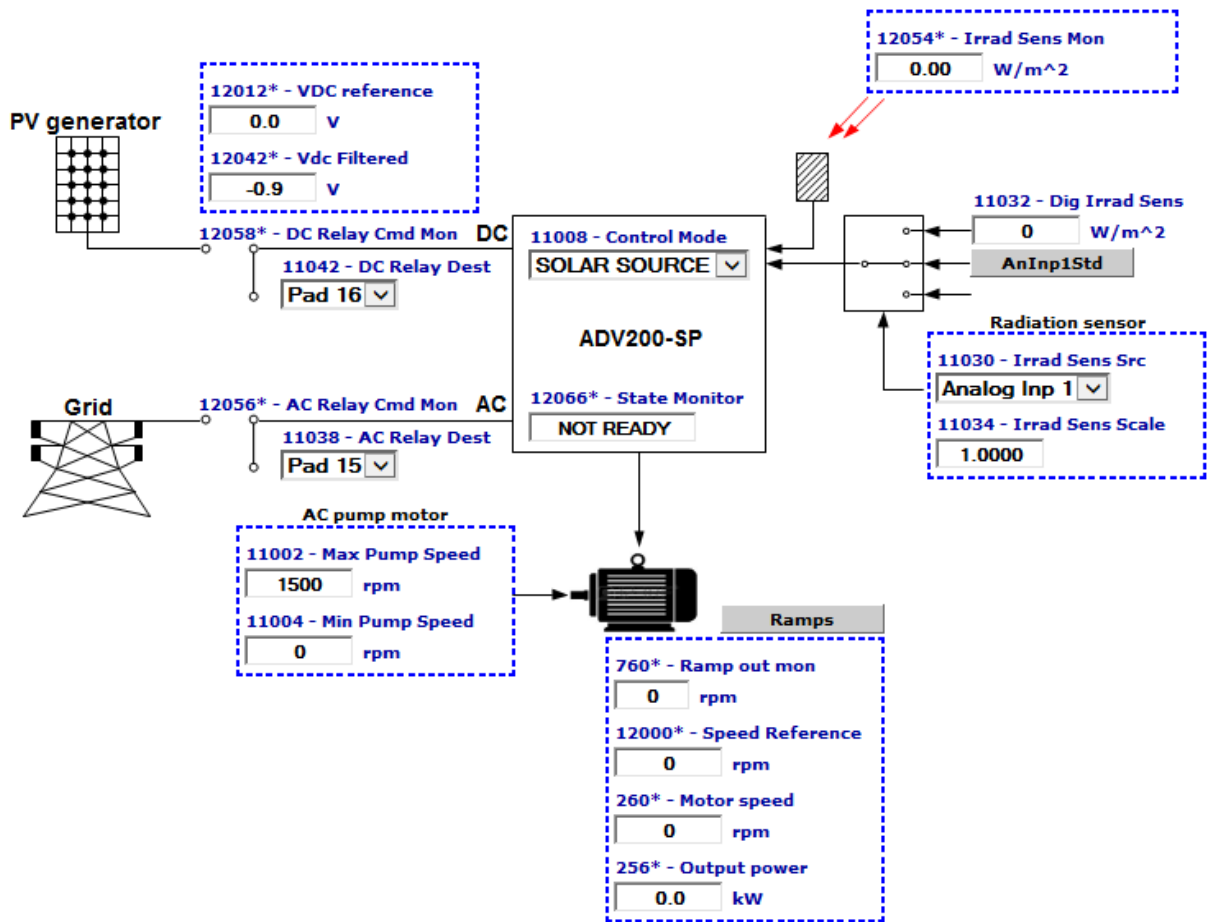

The Solar Pump application provides control for the DC-Link voltage to get the maximum power from the photovoltaic module through the Maximum Power Point Tracker (MPPT) control algorithm. The algorithm regulates the speed of the pump motor from 0 to its maximum speed, which is set in parameter 11002 **Max Pump Speed**, which indicates the maximum pump speed.

27.1 – CONFIGURATION

Menu	PAR	Description	UM	Typo	FB BIT	Def	Min	Max	Acc	Mod
27.1.1	11000	App Enable	-	BIT		OFF	-	-	RW	VS

To enable the application functions, the **App Enable** parameter has to be set to ON (it is necessary to have run the **Startup wizard** and the application's **Auto-Setup** command; see the Startup procedure indicated in section 7.1 of the ADV200 SP QS manual).

Menu	PAR	Description	UM	Typo	FB BIT	Def	Min	Max	Acc	Mod
27.1.2	11002	Max Pump Speed	rpm	FLOAT		1500	0	10000	RW	VS

This indicates the maximum speed value that can be set by the application. The value must not exceed the maximum motor speed (PAR 680 **Full-scale speed**) entered during the **Startup wizard** procedure:

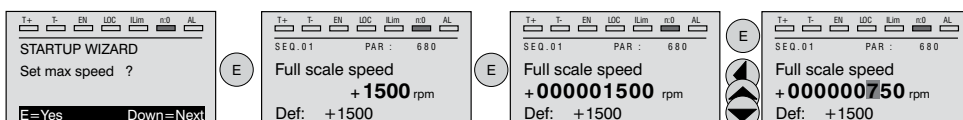

Menu	PAR	Description	UM	Typo	FB BIT	Def	Min	Max	Acc	Mod
27.1.3	11004	Min Pump Speed	rpm	FLOAT		0	0	10000	RW	VS

Setting the minimum speed: set the value desired. During normal operation, the application will bring the speed to values equal to or greater than those set in the parameter. These values can be ignored during the starting ramp and during the motor stop.

Note !

The MIN FREQUENCY function can be used to set ramps with different acceleration rates. For proper operation, it is recommended that a minimum speed value be set higher than the speed setting in the MIN FREQUENCY function.

Menu	PAR	Description	UM	Typo	FB BIT	Def	Min	Max	Acc	Mod
27.1.4	11006	Auto Setup	-	BIT		Off	-	-	RW	VS

This automatically sets the system parameters required for the application to run.

It has to be set = ON before starting the first time (Enable pin 7 contact / S3 = disabled).

Menu	PAR	Description	UM	Typo	FB BIT	Def	Min	Max	Acc	Mod
27.1.5	11008	Control Mode	-	ENUM		0	-	-	RW	VS

System control mode:

- 0 SOLAR SOURCE Island operating mode. There are no secondary sources allowed other than power supplied by panels.
In this operating mode, the drive will run when PAR 1207 **DC Connection Req** conditions have been met and will remain running until PAR 12072 **AC Connection Req** conditions have been met.
- 1 AUTO DUAL SRC Exclusive selection mode between panel and mains operation.
In this operating mode, the drive will be running through the DC source when PAR 12070 **DC Connection Req** conditions have been met and will switch to AC operation (exclusively) when PAR 12072 **AC Connection Req** conditions have been met.
During AC operation, the MPPT control will be excluded and the reference control voltage will be equal to what has been set in parameter PAR 11202 **MPPT Vdc Nom Point**.
- 2 AC SOURCE Exclusive mains operation
During AC operation, the MPPT control will be excluded and the reference control voltage will be equal to what has been set in parameter PAR 11202 **MPPT Vdc Nom Point**.
- 3 AUTO HYBRID Simultaneous mains and panel operation.
In this operating mode, the drive will be running through the DC source when PAR 12070 **DC Connection Req** conditions have been met and will switch to AC together with DC operation when PAR 12072 **AC Connection Req** conditions have been met.
During AC operation, the MPPT control will be excluded and the reference control voltage will be equal to what has been set in parameter PAR11202 **MPPT Vdc Nom Point**.

Menu	PAR	Description	UM	Typo	FB BIT	Def	Min	Max	Acc	Mod
27.1.6	11010	Quick Setup	*	ENUM	*	Off	*	*	RW	VS

Quick system setup with scenarios predefined during commissioning.

The purpose of this function is to simplify commissioning of the application by setting up the system and modifying the voltage control and MPPT parameters.

Options available:

- 0 Off Function disabled
- 1 Standard The default control values reported in the Standard column are preloaded
- 2 Fast The control values reported in FAST column are preloaded.

PAR	Description	Standard	Fast
11108	Kp Amplif for GS1	2.0	3.0
11110	Ki Amplif for GS1	1.0	3.0
11106	Voltage Gap for GS1	25.0	50.0
11112	GS filter Constant	0.2	2.0
11120	Acceleration Ramp	1.0	10.0
11122	Deceleration Ramp	1.0	0.05
11224	MPPT Voltage Step	2.0	0.5
11280	En Stability VDC	OFF	ON
11282	Speed Red (pc)	0.7	1.0
11284	Min Speed for St cnt	2000.0	500.0
11286	Variation of Vdc	0.05	0.02
11288	Low Value Gain Stab	0.1	0.05

27.2 – ALARM

Menu	PAR	Description	UM	Typo	FB BIT	Def	Min	Max	Acc	Mod
27.2.1	11350	Min speed AI Act	*	ENUM	*	Ignore	*	*	RW	VS

Action required to trip the minimum speed alarm.

The function checks whether the drive is below minimum speed for longer than the allotted time setting as this could damage the system or decrease its efficiency.

This function checks that, while the drive is running, its speed remains above the minimum set by parameter 11004 **Min Pump Speed** with maximum timeout specified by parameter 11352 **Min Speed At TimeOut**; if not, the action requested by this parameter is implemented.

Bit 0 in mask 11260 **Reset Alarm Mask Hi** (= 1) must be enabled in order to automatically reset the alarm condition.

Menu	PAR	Description	UM	Typo	FB BIT	Def	Min	Max	Acc	Mod
27.2.2	11352	Min speed AI TimeOut	s	DINT	*	30	1	1000	RW	VS

Maximum time admissible for remaining below the minimum speed.

This time must be set according to the set acceleration and deceleration ramps (ref. PAR 700, 714).

27.3 – I/O

Menu	PAR	Description	UM	Typo	FB BIT	Def	Min	Max	Acc	Mod
27.3.1	11030	Irrad Sens Src	-	ENUM		1550	-	-	RW	VS

Radiation sensor input.

- 6000 NULL
- 1 DIGITAL
- 1500 ANALOG INP 1
- 1550 ANALOG INP 2

Menu	PAR	Description	UM	Typo	FB BIT	Def	Min	Max	Acc	Mod
27.3.2	11032	Dig Irrad Sens	W/m ²	INT16		0	0	5000	RW	VS

Digital Radiation sensor input.

The reading of the Radiation sensor through this parameter is done by setting **Irrad Sens Src** (PAR 11030) to DIGITAL.

Menu	PAR	Description	UM	Typo	FB BIT	Def	Min	Max	Acc	Mod
27.3.3	11034	Irrad Sens Scale	-	FLOAT		1000.0	0.001	5000.0	RW	VS

Scale applied to the analog Radiation sensor reading.

Menu	PAR	Description	UM	Typo	FB BIT	Def	Min	Max	Acc	Mod
27.3.4	11038	AC Relay Dest	-	ENUM		PAD15	-	-	RW	VS

Destination of the relay close command to connect the drive to the AC mains.

For the relay command to be effective, the dedicated relative digital output parameter must be configured in the DIGITAL OUTPUTS menu.

Example: under the default configuration, the command **PAD15** must be selected at digital output 3 (PAR 1314 **Digital output 3 src = PAD15**, DIGITAL OUTPUTS menu).

- 3716 Pad 9
- 3718 Pad 10
- 3720 Pad 11
- 3722 Pad 12
- 3724 Pad 13
- 3726 Pad 14
- 3728 Pad 15
- 3730 Pad 16
- 6000 Null

Menu	PAR	Description	UM	Typo	FB BIT	Def	Min	Max	Acc	Mod
27.3.5	11042	DC Relay Dest	-	ENUM		PAD16	-	-	RW	VS

Destination of the relay close command to connect the drive to the DC mains.

For the relay command to be effective, the dedicated relative digital output parameter must be configured in the DIGITAL OUTPUTS menu.

Example: under the default configuration, the command **PAD16** (source) must be selected at digital output 4 (PAR 1316 **Digital output 4 src = PAD16**, DIGITAL OUTPUTS menu).

Menu	PAR	Description	UM	Typo	FB BIT	Def	Min	Max	Acc	Mod
27.3.6	11044	En MS Cntr Mode	-	ENUM		-	-	-	RW	VS

- 0 Cmd Based
- 1 Dig Inp Based
- 2 Disabled

If the parameter is set to 0 - Cmd Based: the operation of the machine in states that manage initialization and/or change to AC and DC mode, which is determined directly by the value of parameter 11008.

If the parameter is set to 1 - Dig Inp Based: enabling the operation selection command 11008 is controlled by a digital input, according to a logical combination of the sources specified in 11046 and 11048 according to the table below:

Status of the parameter PAR 11046 (MANUAL – AUTO)	Status of the parameter PAR 11048 (MODE)	Control Mode IPA 11008
OFF	OFF	SOLAR SOURCE
OFF	ON	AC SOURCE
ON	OFF	AUTO DUAL SRC
ON	ON	AUTO HYBRID SRC

If the parameter is set to 2 -Disabled: the machine status is disabled, causing the settings of parameter 11008 to not be considered. Starting and stopping the inverter will only be based on the START commands and not on the conditions set by the parameters described in the SOURCE MANAGER menu.

This mode is dedicated to operation with externally managed relays.

Menu	PAR	Description	UM	Typo	FB BIT	Def	Min	Max	Acc	Mod
27.3.7	11046	Src for MAN-AUTO mode	-	ENUM		-	-	-	RW	VS

Signal source for setting the type of control (manual OFF, automatic ON).

See the table below.

1112 Dig Inp 1
1114 Dig Inp 2
1116 Dig Inp 3
1118 Dig Inp 4
1120 Dig Inp 5
1210 Dig Inp 1X
1212 Dig Inp 2X
1214 Dig Inp 3X
1216 Dig Inp 4X
1218 Dig Inp 5X
1220 Dig Inp 6X
1222 Dig Inp 7X
1224 Dig Inp 8X
4454 Bit0 dec mon
4456 Bit1 dec mon
4458 Bit2 dec mon
4460 Bit3 dec mon
4462 Bit4 dec mon
4464 Bit5 dec mon
4466 Bit6 dec mon
4468 Bit7 dec mon
4470 Bit8 dec mon
4472 Bit9 dec mon
4474 Bit10 dec mon
4476 Bit11 dec mon
4478 Bit12 dec mon
4480 Bit13 dec mon
4482 Bit14 dec mon
4484 Bit15 dec mon
6000 Null
6002 One

Menu	PAR	Description	UM	Typo	FB BIT	Def	Min	Max	Acc	Mod
27.3.8	11048	Src for TYPE of CNT	-	ENUM		-	-	-	RW	VS

Signal source for setting the type of control.
See the PAR 11046 selection list.

Menu	PAR	Description	UM	Typo	FB BIT	Def	Min	Max	Acc	Mod
27.3.9	11380	An Input to Top Ramp	*	ENUM	*	Null	*	*	RW	VS

Selection of the analogical input the application uses to modify PAR 634 **Ramp ref top lim** as long as it is higher than the pump minimum speed setting (PAR 11004).

The parameter may have the following values:

NULL The function is disabled
Analog Inp 1 The value of analog 1, scaled with the FULL-SCALE speed, is copied.
Analog Inp 2 The value of analog 2, scaled with the FULL-SCALE speed, is copied.
Ext An Inp 1 The value of analog Ext 1, scaled with the FULL-SCALE speed, is copied.
Ext An Inp 2 The value of analog Ext 2, scaled with the FULL-SCALE speed, is copied.

This function can prove useful when pumps/inverters are being operated with a common DC-BUS.

In this scenario, MPPT must be active for one drive (Master), while the second (Slave) receives the analog-generated reference. Through this parameter, the slave drive can operate at independent speed, but this is limited by the Master in cases of low insolation.

Menu	PAR	Description	UM	Typo	FB BIT	Def	Min	Max	Acc	Mod
27.3.10	12054	Irrad Sens Mon	W/m ²	FLOAT		-	-	-	RVS	VS

Radiation sensor monitor.

27.4 – SOURCE MANAGER

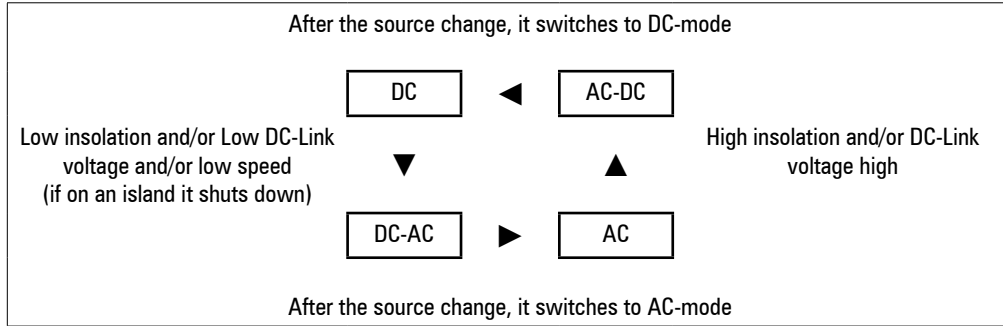

Simplified operating mode diagram

Menu	PAR	Description	UM	Typo	FB BIT	Def	Min	Max	Acc	Mod
27.4.1	11050	AC-DC Switch mode	-	ENUM	-	-	-	-	RW	VS

During the source change, this defines whether the pump must stop (0 STOP SWITCH) or move to the speed specified by parameter 11052 **Switch speed** (1 RUN SWITCH).

When changing sources, the motor and pump must have no load.

- 0 STOP SWITCH
- 1 RUN SWITCH

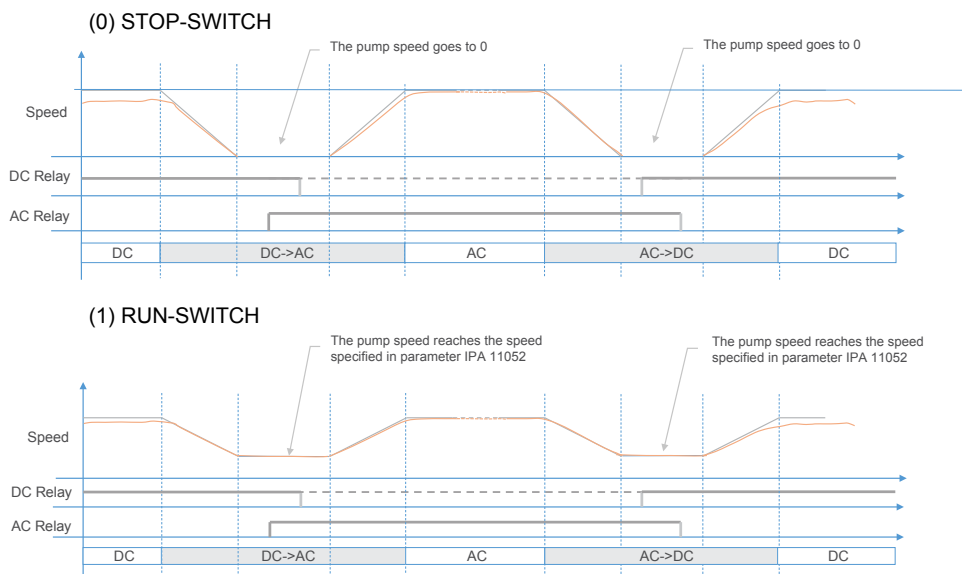

Menu	PAR	Description	UM	Typo	FB BIT	Def	Min	Max	Acc	Mod
27.4.2	11052	Switch speed	Rpm	INT16	-	1000	0	10000	RW	VS

This indicates the maximum speed at which the pump will change sources during the transition (see Run-Switch).

Menu	PAR	Description	UM	Typo	FB BIT	Def	Min	Max	Acc	Mod
27.4.3	11060	Irrad HIGH Thr	W/m ²	FLOAT	-	400	0	10000	RW	VS

Minimum insolation value for start up. The monitor value of the Radiation sensor is given by the parameter PAR 12054 **Irrad Sens Mon** reading.

The condition is considered to have been met if the sensor value exceeds the threshold setting.

Menu	PAR	Description	UM	Typo	FB BIT	Def	Min	Max	Acc	Mod
27.4.4	11062	Vdc HIGH Thr	V	FLOAT	-	550	0	800	RW	VS

Minimum DC-LINK voltage value for start up. The condition is considered to have been met if the DC-LINK voltage exceeds the threshold setting.

Menu	PAR	Description	UM	Typo	FB BIT	Def	Min	Max	Acc	Mod
27.4.5	11066	Cond Trans DC-Mode	-	LOGIC		OR	-	-	RW	VS

- 1 OR
- 2 AND

Logical condition for start-up and/or transition to operation with PV panels based on the status of the conditions linked to the parameters PAR 11060 and PAR 11062

The condition status is monitored by the PAR 12070 **DC Connection Req** variable.

Menu	PAR	Description	UM	Typo	FB BIT	Def	Min	Max	Acc	Mod
27.4.6	11070	Irrad LOW Thr	W/m ²	FLOAT	400	0	10000		RW	VS VS

Insolation threshold value at which a stop or a switch to mains operation is required.

The monitor value of the Radiation sensor is given by the parameter PAR 12054 **Irrad Sens Mon** reading.

The condition is considered to have been met if the sensor value is below the threshold setting.

Menu	PAR	Description	UM	Typo	FB BIT	Def	Min	Max	Acc	Mod
27.4.7	11072	Vdc LOW Thr	V	FLOAT		400.0	300.0	800.0	RW	VS

DC-Link voltage threshold value at which a stop or a switch to mains operation is required. The condition is considered to have been met if the DC-LINK voltage is below the threshold setting.

Menu	PAR	Description	UM	Typo	FB BIT	Def	Min	Max	Acc	Mod
27.4.8	11074	Speed Thr	RPM	FLOAT		1000.0	0.0	10000.0	RW	VS

Motor speed threshold value at which a stop or a switch to mains operation is required. The condition is considered to have been met if the motor speed is below the threshold setting. The speed is expressed in RPM.

Menu	PAR	Description	UM	Typo	FB BIT	Def	Min	Max	Acc	Mod
27.4.9	11076	Irrad Trans Condd	-			AND	-	-	RW	VS

- 1 OR
- 2 AND (after)
- 3 AND (before)

Operator to be used for the status of the radiation sensor value compared to the PAR 11070 **Irrad LOW Thr** threshold for the change/request to go to mains operation.

The status of the overall condition given by the PAR 11076, 11078 and 11080 parameters is monitored by the PAR 12072 **AC Connection Req** variable.

Notes on the conditions at 3-levels:

AND (after): the current and previous conditions must be checked. The variable is processed after the conditions in OR

AND (before): the current and previous conditions must be checked. The variable is processed before the conditions in OR

Example:

The transition is to be made when the Radiation sensor is below the threshold or when both the VDC voltage and the motor speed are below the threshold setting:

(VDC AND SPEED) OR IRR =

11076 IRR = OR

11078 VDC = AND (before)

11080 SPD = AND (before)

The transition is to be made when the Radiation sensor condition or the DC Link voltage is checked, and at the same time, the speed is below the threshold setting.

(VDC OR IRR) AND SPD =

11076 IRR = OR

11078 VDC = OR

11080 SPD = AND (after)

Menu	PAR	Description	UM	Typo	FB BIT	Def	Min	Max	Acc	Mod
27.4.10	11078	Vdc Trans Cond	-			AND	-	-	RW	VS
		1 OR								
		2 AND (after)								
		3 AND (before)								

Operator to be used for the status of the Radiation sensor value compared to the PAR 11072 **Vdc LOW Thr** threshold for the change/request to go to mains operation.

The status of the overall condition given by the 11076, 11078 and 11080 parameters is monitored by the PAR 12072 **AC Connection Req** variable.

Menu	PAR	Description	UM	Typo	FB BIT	Def	Min	Max	Acc	Mod
27.4.11	11080	Spd Trans Cond	-			AND	-	-	RW	VS
		1 OR								
		2 AND (after)								
		3 AND (before)								

Operator to be used for the status of the speed sensor value compared to the PAR 11074 **Speed Thr** threshold for the change/request to go to mains operation.

The status of the overall condition given by the PAR 11076, 11078 and 11080 parameters is monitored by the PAR 12072 **AC Connection Req** variable

Menu	PAR	Description	UM	Typo	FB BIT	Def	Min	Max	Acc	Mod
27.4.12	11082	State Sw Hold Off	s	INT16		20	-	-	ERW	VS

HOLD off time for checking the conditions listed above.

Menu	PAR	Description	UM	Typo	FB BIT	Def	Min	Max	Acc	Mod
27.4.13	11084	Switch Delay	s	INT16		5	-	-	ERW	VS

Determines the pauses between switching relays on/off for mode changes.

Menu	PAR	Description	UM	Typo	FB BIT	Def	Min	Max	Acc	Mod
27.4.14	12056	AC Relay Cmd Mon	-	BIT		-	-	-	R	VS

Command value calculated for the AC relay (command to close the relay for the mains/generator source

Note ! To make the command effective, the variable defined by the PAR 11038 **AC Relay Dest** parameter must be connected to the digital output connected to the AC control relay.

Menu	PAR	Description	UM	Typo	FB BIT	Def	Min	Max	Acc	Mod
27.4.15	12058	DC Relay Cmd Mon	-	BIT		-	-	-	R	VS

Command value calculated for the DC relay (command to close the relay for the solar panel source).

Note ! To make the command effective, the variable defined by the PAR 11042 **DC Relay Dest** parameter must be connected to the digital output connected to the DC control relay.

Menu	PAR	Description	UM	Typo	FB BIT	Def	Min	Max	Acc	Mod
27.4.16	12060	SM Start Cmd	-	BIT		-	-	-	R	VS

START command determined by the machine statuses. This command is inserted in the START command chain, which is managed through **Pad 4** (PAR 3706, menu 22.9 - FUNCTIONS/PADS).

27.5 – VDC CONTROL

Menu	PAR	Description	UM	Typo	FB BIT	Def	Min	Max	Acc	Mod
27.5.1	11100	VDC Control Enable	-	BIT		-	-	-	ERW	VS

Enables voltage control (normally it should be left set to ON).

Menu	PAR	Description	UM	Typo	FB BIT	Def	Min	Max	Acc	Mod
27.5.2	11102	Kp Gain VDC control	-	FLOAT		1	0	10000	RW	VS

Proportional gain for the DC-LINK voltage control regulator. This should be raised for a faster response during changes in insolation or load, it should be lowered in case of instability.

Menu	PAR	Description	UM	Typo	FB BIT	Def	Min	Max	Acc	Mod
27.5.3	11104	Ki Gain Vdc control	-	FLOAT		10	0	10000	RW	VS

Integral gain for the DC-LINK voltage control regulator.

Menu	PAR	Description	UM	Typo	FB BIT	Def	Min	Max	Acc	Mod
27.5.4	11106	Voltage Gap for GS1	V	FLOAT		25	0	300	ERW	VS

Voltage limit for which the gain scaling function is activated (only if the voltage setting is higher than the value currently set).

Menu	PAR	Description	UM	Typo	FB BIT	Def	Min	Max	Acc	Mod
27.5.5	11108	Kp Amplif for GS1	-	FLOAT		2	0.1	100	ERW	VS

Proportional gain amplification factor when there is a deviation from the setpoint value of the voltage setting.

Menu	PAR	Description	UM	Typo	FB BIT	Def	Min	Max	Acc	Mod
27.5.6	11110	Ki Amplif for GS1	-	FLOAT		1	0.1	100	ERW	VS

Integral gain amplification factor when there is a deviation from the setpoint value of the voltage setting.

Menu	PAR	Description	UM	Typo	FB BIT	Def	Min	Max	Acc	Mod
27.5.7	11112	GS Filter constant	Hz	FLOAT		0,2	0,02	60	ERW	VS

Connection time for dynamic gain change.

Menu	PAR	Description	UM	Typo	FB BIT	Def	Min	Max	Acc	Mod
27.5.8	11120	Acceleration Ramp	-	FLOAT		1	0	1000	ERW	VS

Ramp acceleration limit for control.

Menu	PAR	Description	UM	Typo	FB BIT	Def	Min	Max	Acc	Mod
27.5.9	11122	Deceleration Ramp	-	FLOAT		1	0	1000	ERW	VS

Ramp deceleration limit for control.

Menu	PAR	Description	UM	Typo	FB BIT	Def	Min	Max	Acc	Mod
27.5.10	12044	Prop Act	-	FLOAT		-	-	-	ER	VS

Proportional action monitor.

Menu	PAR	Description	UM	Typo	FB BIT	Def	Min	Max	Acc	Mod
27.5.11	12046	Int Act	-	FLOAT		-	-	-	ER	VS

Integral action monitor.

Menu	PAR	Description	UM	Typo	FB BIT	Def	Min	Max	Acc	Mod
27.5.12	12074	KplnUse	-	FLOAT		-	-	-	ER	VS
Current value of proportional gain										

Menu	PAR	Description	UM	Typo	FB BIT	Def	Min	Max	Acc	Mod
27.5.13	12076	KtlnUse	-	FLOAT		-	-	-	ER	VS
Current value of integral gain.										

27.6 – MPPT

Menu	PAR	Description	UM	Typo	FB BIT	Def	Min	Max	Acc	Mod
27.6.1	11200	MPPT type	-	ENUM		P/O	-	-	RW	VS

Type of MPPT used

None: The MPPT algorithm is not used. The DC-LINK reference voltage is kept constant and equal to the value read in the PAR 11202 **MPPT Vdc Nom Point** parameter.

Threshold: this provides for a defined operating point, which is modified through preset thresholds depending on the motor speed.

P/O (Def.): this method is based on “Perturb” and “Observe”, which involves continuously perturbing the system to obtain an optimum operating point.

Menu	PAR	Description	UM	Typo	FB BIT	Def	Min	Max	Acc	Mod
27.6.2	11202	MPPT Vdc Nom Point	-	FLOAT		520	400	700	RW	VS

Nominal operating point, which can be calculated using knowledge of the photovoltaic panel specifications.

Menu	PAR	Description	UM	Typo	FB BIT	Def	Min	Max	Acc	Mod
27.6.3	11204	MPPT Ramp Acc	V/s	FLOAT		1	-	-	ERW	VS

Ramp value used by the MPPT algorithm.

Menu	PAR	Description	UM	Typo	FB BIT	Def	Min	Max	Acc	Mod
27.6.4	11206	Min MPPT Vdc Ref	V	FLOAT		400	300	600	RW	VS

Minimum DC-Link voltage value that can be set by the MPPT algorithm.

Menu	PAR	Description	UM	Typo	FB BIT	Def	Min	Max	Acc	Mod
27.6.5	11208	Max MPPT Vdc Ref	V	FLOAT		700	300	1000	RW	VS

Maximum DC-Link voltage value that can be set by the MPPT algorithm.

Menu	PAR	Description	UM	Typo	FB BIT	Def	Min	Max	Acc	Mod
27.6.6	11210	MPPT Low Sp Off	-	FLOAT		-20	-200	200	ERW	VS

Voltage offset from the low speed (<66%) nominal value with reference to the maximum speed setting. (1)

Menu	PAR	Description	UM	Typo	FB BIT	Def	Min	Max	Acc	Mod
27.6.7	11212	MPPT Med Sp Off	-	FLOAT		-10	-200	200	ERW	VS

Voltage offset from the medium speed (<83%) nominal value with reference to the maximum speed setting. (1)

Menu	PAR	Description	UM	Typo	FB BIT	Def	Min	Max	Acc	Mod
27.6.8	11214	Ratio Vmpp Vo	%	FLOAT		80	50	100	ERW	VS

Ratio between the panels' maximum power voltage and their no-load voltage.

Menu	PAR	Description	UM	Typo	FB BIT	Def	Min	Max	Acc	Mod
27.6.9	11220	MPPT Trigger count	ms	UINT16		1000	0	60000	ERW	VS

Indicates how often (ms) the MPPT algorithm is triggered. (2)

Menu	PAR	Description	UM	Typo	FB BIT	Def	Min	Max	Acc	Mod
27.6.10	11222	MPPT N of Cnt ch dir	*	WORD	*	10	0	50	RW	VS

Number of steps before the MPPT algorithm changes direction to find the operating point.

Menu	PAR	Description	UM	Typo	FB BIT	Def	Min	Max	Acc	Mod
27.6.11	11224	MPPT Voltage Step	V/s	FLOAT		2	0	100	ERW	VS
<p>Defines the MPPT algorithm voltage step expressed in V/s. (2)</p>										

Menu	PAR	Description	UM	Typo	FB BIT	Def	Min	Max	Acc	Mod
27.6.12	11228	MPPT Right Gain	-	INT16		2	1	10	ERW	VS
<p>Parameter to improve stability when seeking the operating point.</p>										

-
- (1) Parameter for Threshold algorithm.
 - (2) Parameter for P/O algorithm.

27.7 – AUTORESTORE

Menu	PAR	Description	UM	Typo	FB BIT	Def	Min	Max	Acc	Mod
27.7.1	11250	Auto Restore En	-	BIT		On	-	-	RW	VS

When this parameter is enabled, the system can attempt an automatic reset in case of an alarm.

Menu	PAR	Description	UM	Typo	FB BIT	Def	Min	Max	Acc	Mod
27.7.2	11252	Short Time Restore	s	FLOAT		30	15	3000	RW	VS

Wait time, in seconds, for system restore (first attempt). The number of attempts is set in the PAR 11256 **N of Short Retry** parameter.

Menu	PAR	Description	UM	Typo	FB BIT	Def	Min	Max	Acc	Mod
27.7.3	11254	Long Time Restore	s	FLOAT		600	15	3000	RW	VS

Wait time, in seconds, for system restore if the first attempt fails.

Menu	PAR	Description	UM	Typo	FB BIT	Def	Min	Max	Acc	Mod
27.7.4	11256	N of Short Retry		UINT16		3	-	-	RW	VS

Number of attempts that will be taken into account for the Short Time Restore reset.

Menu	PAR	Description	UM	Typo	FB BIT	Def	Min	Max	Acc	Mod
27.7.5	11258	Reset Alarm Mask Low		UINT32		2	-	-	ERW	VS

Mask inherent to the first alarm word identifying the alarms for which the AUTORESTORE function will attempt automatic reset.

E.g.: to activate automatic reset of the **Undervoltage** alarm (active by default) IPA 11258 = 2

For a complete list of the first word alarms, see parameter 4840.

Menu	PAR	Description	UM	Typo	FB BIT	Def	Min	Max	Acc	Mod
27.7.6	11260	Reset Alarm Mask Hi		UINT32		-	-	-	ERW	VS

Mask inherent to the first alarm word identifying the alarms for which the AUTORESTORE function will attempt automatic reset.

E.g.: to activate automatic reset of the **Min speed** alarm (active by default) IPA 11260 = 1

For a complete list of the first word alarms, see parameter 4842.

Menu	PAR	Description	UM	Typo	FB BIT	Def	Min	Max	Acc	Mod
27.7.7	12032	Time to Next Restore	s	FLOAT		-	-	-	R	VS

Time remaining before the next alarm reset.

Menu	PAR	Description	UM	Typo	FB BIT	Def	Min	Max	Acc	Mod
27.7.8	12034	Number of Retry		UINT16		-	-	-	R	VS

Current status of the number of attempts.

Menu	PAR	Description	UM	Typo	FB BIT	Def	Min	Max	Acc	Mod
27.7.9	12036	Time to Retry Reset	s	FLOAT		-	-	-	R	VS

Time remaining to reset the number of attempts.

27.8 – STABILITY

Menu	PAR	Description	UM	Typo	FB BIT	Def	Min	Max	Acc	Mod
27.8.1	11280	En Stability VDC	-	FLOAT		Off	-	-	RW	VS

Enabling the stability management functions for the DC-LINK control. This function is necessary if there is instability in the voltage control.

Menu	PAR	Description	UM	Typo	FB BIT	Def	Min	Max	Acc	Mod
27.8.2	11282	Speed Red (pc)	-	FLOAT		0.7	0	1	ERW	VS

Maximum speed reduction, if stability control is enabled.

Menu	PAR	Description	UM	Typo	FB BIT	Def	Min	Max	Acc	Mod
27.8.3	11284	Min Speed for St cnt	-	FLOAT		2000	0	3000	ERW	VS

Minimum reference speed, for which stability control is active.

Menu	PAR	Description	UM	Typo	FB BIT	Def	Min	Max	Acc	Mod
27.8.4	11286	Variation of Vdc	-	FLOAT		0.05	0.01	0.5	ERW	VS

Variation in DC voltage permitted during normal operation.

Menu	PAR	Description	UM	Typo	FB BIT	Def	Min	Max	Acc	Mod
27.8.5	11288	Low Value Gain Stab	-	FLOAT		0.1	0.001	0.5	ERW	VS

Maximum reduction of gain control during an unstable phase.

Menu	PAR	Description	UM	Typo	FB BIT	Def	Min	Max	Acc	Mod
27.8.6	12040	StabSpeedRef	-	FLOAT		-	-	-	ER	VS

Reference value of the stability control speed.

27.9 – MONITOR

Menu	PAR	Description	UM	Typo	FB BIT	Def	Min	Max	Acc	Mod
27.9.1	12000	Speed Reference	-	FLOAT	-	-	-	-	R	VS
Calculated control output monitor.										

Menu	PAR	Description	UM	Typo	FB BIT	Def	Min	Max	Acc	Mod
27.9.2	12010	Vdc Set Point Calc	-	FLOAT	-	-	-	-	R	VS
Calculated DC-LINK voltage.										

Menu	PAR	Description	UM	Typo	FB BIT	Def	Min	Max	Acc	Mod
27.9.3	12012	VDC reference	-	FLOAT	-	-	-	-	R	VS
DC-LINK voltage reference										

Menu	PAR	Description	UM	Typo	FB BIT	Def	Min	Max	Acc	Mod
27.9.4	12028	MPPT Vdc Direction	-	FLOAT	-	-	-	-	R	VS
Current search direction of the MPPT control.										

Menu	PAR	Description	UM	Typo	FB BIT	Def	Min	Max	Acc	Mod
27.9.5	12042	Vdc Filtered	-	FLOAT	-	-	-	-	R	VS
Valore attuale della tensione di DC-LINK.										

Menu	PAR	Description	UM	Typo	FB BIT	Def	Min	Max	Acc	Mod
27.9.6	12066	State Monitor	-	FLOAT	-	-	-	-	R	VS
Current value of the DC-LINK voltage.										

0	LOW RAD	The solar source condition is not sufficient to meet start-up conditions.
1	SOLAR SOURCE	The system is connected to the DC source.
2	SOLAR to AC	The system is switching from DC to AC.
3	AC SOURCE	The system is connected to the AC source and/or in combination with DC.
4	AC to SOLAR	The system is switching from AC to DC.
5	RAMP	The system is running the initial or final speed ramp.
6	UNDERVOLTAGE	The system is in alarm and if activated it is performing the reset procedure.
7	NOT READY	The system is not ready. The Enable command is missing.
8	MPPT ON	Operation is with MPPT activated (only if the PAR 11044 command is disabled).
9	VDC CONTROL	Operation is with DC voltage activated (only if the PAR 11044 command is disabled).
10	HYBRID SOURCE	The system is connected to the AC source in combination with DC.
11	SOLAR > HYBRID	The system is switching from DC to combined AC + DC operation.
12	HYBRID > SOLAR	The system is switching from AC + DC to combined DC operation.

Menu	PAR	Description	UM	Typo	FB BIT	Def	Min	Max	Acc	Mod
27.9.7	12070	DC Connection Req	-	BIT	-	-	-	-	R	VS
DC connection request monitor variable.										

Menu	PAR	Description	UM	Typo	FB BIT	Def	Min	Max	Acc	Mod
27.9.8	12072	AC Connection Req	-	BIT	-	-	-	-	R	VS
AC connection request monitor variable.										

27.10 – APP INFO

Menu	PAR	Description	UM	Typo	FB BIT	Def	Min	Max	Acc	Mod
27.10.1	12002	Application Version	-	FLOAT		-	-	-	R	VS
		Application version								

Menu	PAR	Description	UM	Typo	FB BIT	Def	Min	Max	Acc	Mod
27.10.2	12004	App Build date	-	FLOAT		-	-	-	R	VS
		Date application was compiled.								

Menu	PAR	Description	UM	Typo	FB BIT	Def	Min	Max	Acc	Mod
27.10.3	12006	MDPlc Version	-	FLOAT		-	-	-	R	VS
		Version of the compilation program.								

Menu	PAR	Description	UM	Typo	FB BIT	Def	Min	Max	Acc	Mod
27.10.4	12008	Configurator Version	-	FLOAT		-	-	-	R	VS
		Compatibility version of the WEG_eXpress configurator.								

Menu	PAR	Description	UM	Typo	FB BIT	Def	Min	Max	Acc	Mod
27.10.5	12030	Regulation Board SN	-	FLOAT		-	-	-	R	VS
		Serial Number of the control board.								

PARAMETERS ON SELECTION LISTS, BUT NOT DISPLAYED ON KEYPAD

Menu	PAR	Description	UM	Type	FB BIT	Def	Min	Max	Acc	Mod
------	-----	-------------	----	------	--------	-----	-----	-----	-----	-----

262 Motor speed nofilter rpm INT16 16 0 0 0 ER

This parameter indicates the unfiltered motor speed.

Menu	PAR	Description	UM	Type	FB BIT	Def	Min	Max	Acc	Mod
------	-----	-------------	----	------	--------	-----	-----	-----	-----	-----

362 Drive overload trip BIT 16 0 0 1 ER

This signal indicates that the drive is in the overload condition. In the default condition the alarm is not triggered as the relative action is set to **Ignore**.

Menu	PAR	Description	UM	Type	FB BIT	Def	Min	Max	Acc	Mod
------	-----	-------------	----	------	--------	-----	-----	-----	-----	-----

366 Drive overload 80 BIT 16 0 0 1 ER

This signal indicates that the drive has reached 80% of the thermal image accumulator (drive overload).

Menu	PAR	Description	UM	Type	FB BIT	Def	Min	Max	Acc	Mod
------	-----	-------------	----	------	--------	-----	-----	-----	-----	-----

626 Ramp ref out mon rpm INT16 16 0 0 0 ER

This parameter displays the reference value output of the ramp remference function block.

Menu	PAR	Description	UM	Type	FB BIT	Def	Min	Max	Acc	Mod
------	-----	-------------	----	------	--------	-----	-----	-----	-----	-----

760 Ramp out mon rpm INT16 16 0 0 0 ER

This parameter displays the reference value output of the ramp function block.

Menu	PAR	Description	UM	Type	FB BIT	Def	Min	Max	Acc	Mod
------	-----	-------------	----	------	--------	-----	-----	-----	-----	-----

764 Ramp acc state BIT 16 0 0 1 ER

This signal indicates whether the acceleration ramp is active.

Menu	PAR	Description	UM	Type	FB BIT	Def	Min	Max	Acc	Mod
------	-----	-------------	----	------	--------	-----	-----	-----	-----	-----

766 SRamp dec state BIT 16 0 0 1 ER

This signal indicates whether the deceleration ramp is active.

Menu	PAR	Description	UM	Type	FB BIT	Def	Min	Max	Acc	Mod
------	-----	-------------	----	------	--------	-----	-----	-----	-----	-----

934 Ref is 0 BIT 16 0 0 1 ER

This signal is active when the reference is below the limit set in parameter **930 Reference 0 threshold**.

Menu	PAR	Description	UM	Type	FB BIT	Def	Min	Max	Acc	Mod
------	-----	-------------	----	------	--------	-----	-----	-----	-----	-----

936 Ref is 0 delay BIT 16 0 0 1 ER

This parameter is active when the reference is below the threshold set in parameter **930 Reference 0 threshold**. The signal is enabled after the delay set with parameter **932 Reference delay 0**.

Menu	PAR	Description	UM	Type	FB BIT	Def	Min	Max	Acc	Mod
------	-----	-------------	----	------	--------	-----	-----	-----	-----	-----

944 Speed is 0 BIT 16 0 0 1 ER

This parameter is active when the speed is below the threshold set in parameter **940 Speed 0 threshold**.

Menu	PAR	Description	UM	Type	FB BIT	Def	Min	Max	Acc	Mod
------	-----	-------------	----	------	--------	-----	-----	-----	-----	-----

946 Speed is 0 delay BIT 16 0 0 1 ER

This signal is active when the reference is below the threshold set in parameter **940 Speed 0 threshold**. The signal is activated after the delay set in parameter **942 Speed 0 delay**.

Menu	PAR	Description	UM	Type	FB BIT	Def	Min	Max	Acc	Mod
	956	Speed thr 1_2 mon		BIT	16	0	0	1	ER	
<p>To display the speed threshold status: if the motor speed is higher than the value set in parameter 950 Speed threshold 1 or lower than the value set in parameter 952 Speed threshold 2 this parameter assumes the value of 0.</p> <p>If the motor speed is between the value of 950 Speed threshold 1 and that of 952 Speed threshold 2, this parameter assumes the value of 1.</p> <p>Use parameter 954 Speed threshold dly to set a delay time for the transition from 0 to 1 of parameter 956 Speed thr 1_2 mon; the transition from 1 to 0 is always immediate.</p> <p>When 950 Speed threshold 1 is set to a value higher than 952 Speed threshold 2, if the motor speed is between the thresholds this parameter assumes the value of 1. If 950 Speed threshold 1 is set to a value lower than 952 Speed threshold 2, the threshold status is not significant</p>										

Menu	PAR	Description	UM	Type	FB BIT	Def	Min	Max	Acc	Mod
	966	Set speed		BIT	16	0	0	1	ER	
<p>This signal is active when the error between the speed reference and actual motor speed is greater than the tolerance set in parameter 962 Set speed error.</p>										

Menu	PAR	Description	UM	Type	FB BIT	Def	Min	Max	Acc	Mod
	976	Speed thr 3 mon		BIT	16	0	0	1	ER	
<p>The status of the block that detects exceeding of the speed 3 threshold is displayed.</p> <p>0 Actual speed below threshold 1 Actual speed above threshold</p>										

Menu	PAR	Description	UM	Type	FB BIT	Def	Min	Max	Acc	Mod
	986	Current thr mon		BIT	16	0	0	1	ER	
<p>The status of the block that detects exceeding of the current threshold is displayed.</p> <p>0 Actual output current below threshold 1 Actual output current above threshold.</p>										

Menu	PAR	Description	UM	Type	FB BIT	Def	Min	Max	Acc	Mod
	1030	Local/remote mon		BIT	16	0	0	1	ER	
<p>This signal is active when the drive is in the Remote operating mode.</p> <p>0 Local 1 Remote</p>										

Menu	PAR	Description	UM	Type	FB BIT	Def	Min	Max	Acc	Mod
	1060	Sequencer status		UINT16	16	0	0	0	ER	
<p>This signal indicates the state of the “machine states” that controls drive operation.</p> <p>STS_INIT 0 STS_MAGN 1 STS_STOP 2 STS_START 3 STS_FS_STOP 4 STS_FS_START 5 STS_QSTOP 6 STS_FS_MAGN 7 STS_W_QSTOP 8 STS_READY 9 STS_MAGN_START 10 STS_ALM_DISABLED 11 STS_ALM_END_ACTION 12 STS_ALM_STOP 13</p>										

STS_ALM_FSTOP 14
 STS_ALM_R_TO_NORMAL 15
 STS_READY_START 16
 STS_READY_FSTOP 17
 STS_ALM_NO_RESTART 18
 STS_FS_MAGN_START 19

Menu	PAR	Description	UM	Type	FB BIT	Def	Min	Max	Acc	Mod
	1062	Drive OK		BIT	16	0	0	1	ER	

This signal is active when the drive is in the "OK" condition and no alarms are present.
 Connected to the relay output, the normally open relay contact closes when:

- the drive is powered
- no alarm conditions are active.

Menu	PAR	Description	UM	Type	FB BIT	Def	Min	Max	Acc	Mod
	1064	Drive ready		BIT	16	0	0	1	ER	

This signal is active when the drive reference is in the "Ready" to run condition.
 Connected to the relay output, the normally open relay contact closes when:

- the drive is powered
- preloading is complete
- no alarm conditions are active
- the drive is enabled
- motor magnetisation is complete.

Menu	PAR	Description	UM	Type	FB BIT	Def	Min	Max	Acc	Mod
	1110	Digital input E mon		BIT	16	0	0	1	ER	
	1112	Digital input 1 mon		BIT	16	0	0	1	ER	
	1114	Digital input 2 mon		BIT	16	0	0	1	ER	
	1116	Digital input 3 mon		BIT	16	0	0	1	ER	
	1118	Digital input 4 mon		BIT	16	0	0	1	ER	
	1120	Digital input 5 mon		BIT	16	0	0	1	ER	

These signals represent the state of the corresponding digital input.

Menu	PAR	Description	UM	Type	FB BIT	Def	Min	Max	Acc	Mod
	1210	Digital input 1X mon		BIT	16	0	0	1	ER	
	1212	Digital input 2X mon		BIT	16	0	0	1	ER	
	1214	Digital input 3X mon		BIT	16	0	0	1	ER	
	1216	Digital input 4X mon		BIT	16	0	0	1	ER	
	1218	Digital input 5X mon		BIT	16	0	0	1	ER	
	1220	Digital input 6X mon		BIT	16	0	0	1	ER	
	1222	Digital input 7X mon		BIT	16	0	0	1	ER	
	1224	Digital input 8X mon		BIT	16	0	0	1	ER	

These signals represent the state of the corresponding digital input on the expansion card..

Menu	PAR	Description	UM	Type	FB BIT	Def	Min	Max	Acc	Mod
	1530	Analog inp1		BIT	16	0	0	1	ER	

This signal is active when the value of the analog input is below the threshold set in parameter **1520 Analog inp 1 thr.**

Menu	PAR	Description	UM	Type	FB BIT	Def	Min	Max	Acc	Mod
	1580	Analog inp2		BIT	16	0	0	1	ER	

This signal is active when the value of the analog input is below the threshold set in parameter **1570 Analog inp 2 thr.**

Menu	PAR	Description	UM	Type	FB BIT	Def	Min	Max	Acc	Mod
	3006	Speed ratio out mon	rpm	INT16	16	0	0	0	ER	
		This parameter displays the value of the speed ratio used by the “Speed draw” function (speed ratio).								
Menu	PAR	Description	UM	Type	FB BIT	Def	Min	Max	Acc	Mod
	3180	Brake control mon	rpm	INT16	16	0	0	1	ER	
		This parameter displays the status of the brake command.								
		<ul style="list-style-type: none"> 0 Brake closed 1 Brake open 								
Menu	PAR	Description	UM	Type	FB BIT	Def	Min	Max	Acc	Mod
	3214	Motor overload trip		BIT	16	0	0	1	ER	
		This signal is active when the drive is in the motor overload alarm condition.								
Menu	PAR	Description	UM	Type	FB BIT	Def	Min	Max	Acc	Mod
	3262	Bres overload trip		BIT	16	0	0	1	ER	
		This signal is active when the drive is in the braking resistor overload alarm condition.								
Menu	PAR	Description	UM	Type	FB BIT	Def	Min	Max	Acc	Mod
	3374	Vf catch out		INT32	16	0	0	0	ER	
		The voltage applied during capture on-the-fly of the motor in Vf mode is displayed.								
Menu	PAR	Description	UM	Type	FB BIT	Def	Min	Max	Acc	Mod
	3442	Powerloss rampdown		BIT	16	0	0	1	ER	
		This parameter indicates the status of the Powerloss function deceleration ramp								
		<ul style="list-style-type: none"> 0 Powerloss function deceleration ramp not ended 1 Powerloss function deceleration ramp ended 								
		The signal is enabled at the end of the Powerloss function deceleration ramp.								
		The signal is disabled at different times depending on the Powerloss mode setting.								
Menu	PAR	Description	UM	Type	FB BIT	Def	Min	Max	Acc	Mod
	3446	Powerloss nexratio		INT32	32	0	0	0	ER	
		This parameter gives the ratio between the motor speed and the speed reference.								
		For machines with several drives, line synchronisation can be achieved by connecting the Powerloss mode output of the master to the Speed ratio src input of the slave drives. The master => slave connection can be achieved via analog signals or fieldbus.								
		The value 2^30 corresponds to a ratio of 1.								
Menu	PAR	Description	UM	Type	FB BIT	Def	Min	Max	Acc	Mod
	3448	Powerloss nextactive		BIT	16	0	0	1	ER	
		This parameter indicates the status of the Powerloss function								
		<ul style="list-style-type: none"> 0 Powerloss not enabled 1 Powerloss enabled 								
		The function is enabled when there is a power failure.								
		The function is disabled at different times depending on the Powerloss mode setting.								

Menu	PAR	Description	UM	Type	FB BIT	Def	Min	Max	Acc	Mod
	3480	Vdc ctrl ramp freeze		BIT	16	0	0	1	ER	
		This parameter displays when the deceleration ramp block is requested during the Vdc control function .								
		<ul style="list-style-type: none"> 0 VdcCtrl function not enabled 1 VdcCtrl function enabled 								
Menu	PAR	Description	UM	Type	FB BIT	Def	Min	Max	Acc	Mod
	4372	DS402 status word		UINT16	16	0	0	65535	ER	
		This parameter displays the status word according to the DS402 profile. For more information reference should be made to the fieldbus manual.								
Menu	PAR	Description	UM	Type	FB BIT	Def	Min	Max	Acc	Mod
	4394	PFdrv status word 1		UINT16	16	0	0	65535	ER	
		This parameter displays the status word 1 according to the Profdrives profile. For more information reference should be made to the fieldbus manual.								
Menu	PAR	Description	UM	Type	FB BIT	Def	Min	Max	Acc	Mod
	4396	PFdrv status word 2		UINT16	16	0	0	65535	ER	
		This parameter displays the status word 2 according to the Profdrives profile. For more information reference should be made to the fieldbus manual.								
Menu	PAR	Description	UM	Type	FB BIT	Def	Min	Max	Acc	Mod
	4708	Alm dig out mon 1		BIT	16	0	0	1	ER	
		This signal is activated when the alarm configured in parameter 4700 alarm dig sel 1 is active.								
Menu	PAR	Description	UM	Type	FB BIT	Def	Min	Max	Acc	Mod
	4710	Alm dig out mon 2		BIT	16	0	0	1	ER	
		This signal is activated when the alarm configured in parameter 4702 alarm dig sel 2 is active.								
Menu	PAR	Description	UM	Type	FB BIT	Def	Min	Max	Acc	Mod
	4712	Alm dig out mon 3		BIT	16	0	0	1	ER	
		This signal is activated when the alarm configured in parameter 4704 alarm dig sel 3 is active.								
Menu	PAR	Description	UM	Type	FB BIT	Def	Min	Max	Acc	Mod
	4714	Alm dig out mon 4		BIT	16	0	0	1	ER	
		This signal is activated when the alarm configured in parameter 4706 alarm dig sel 4 is active.								
Menu	PAR	Description	UM	Type	FB BIT	Def	Min	Max	Acc	Mod
	4770	First alarm		UINT32	16	0	0	0	ERW	
		This parameter displays the first alarm to be activated.								
		<ul style="list-style-type: none"> 0 No alarm 1 Overvoltage 2 Undervoltage 3 Ground fault 4 Overcurrent 5 Desaturation 6 MultiUndervolt 7 MultiOvercurr 8 MultiDesat 9 Heatsink OT 10 Heatsinks OTUT 								

- 11 Intakeair OT
- 12 Motor OT
- 13 Drive overload
- 14 Motor overload
- 15 Bres overload
- 16 Phaseloss
- 17 Opt Bus fault
- 18 Opt 1 IO fault
- 19 Opt 2 IO fault
- 20 Not Used1
- 21 External fault
- 22 Not Used2
- 23 Overspeed
- 24 Speed ref loss
- 25 Emg stop alarm
- 26 Power down
- 27 Broken belt
- 28 End curve
- 29 Dry pump
- 30 No flow
- 31 Clean alarm
- 33 Min Speed
- 33 Plc1 fault
- 34 Plc2 fault
- 35 Plc3 fault
- 36 Plc4 fault
- 37 Plc5 fault
- 38 Plc6 fault
- 39 Plc7 fault
- 40 Plc8 fault

Menu	PAR	Description	UM	Type	FB BIT	Def	Min	Max	Acc	Mod
	4780	Alarm PLC		UINT16		0	0	0	ER	

This parameter displays the state of the alarms generated by the application written with the internal PLC

Bit	Description
0	1 = Min Speed active
1	1 = PLC 2 fault active
2	1 = PLC 3 fault active
3	1 = PLC 4 fault active
4	1 = PLC 5 fault active
5	1 = PLC 6 fault active
6	1 = PLC 7 fault active
7	1 = PLC 8 fault active

Menu	PAR	Description	UM	Type	FB BIT	Def	Min	Max	Acc	Mod
	4840	Alarm lo state		UINT32	32	0	0	0	ER	

This parameter displays the state of alarms 1..32 of the drive.

Bit	Description
0	1 = Overvoltage active
1	1 = Undervoltage active
2	1 = Ground fault active
3	1 = Overcurrent active
4	1 = Desaturation active
5	1 – MultiUndervolt active
6	1 = MultiOvercurr active
7	1 – MultiDesat active
8	1 = Heatsink OT active

9	1 = Heatsink lin OT active
10	1 = Air OT active
11	1 = Motor OT active
12	1 = Drive overload active
13	1 = Motor overload active
14	1 = Bres overload active
15	1 = Phase loss active
16	1 = Opt bus fault active
17	1 = Opt 1 I/O fault active
18	1 = Opt 2 I/O fault active
19	1 = not used
20	1 = External fault active
21	1 = Fbk loss active
22	1 = Overspeed active
23	1 = Ref loss active
24	1 = Emg stop alarm active
25	1 = Power down active
26	1 = Broken belt active
27	1 = End curve active
28	1 = Dry pump active
29	1 = No flow active
30	1 = Clean alarm active
31	1 = not used

Menu	PAR	Description	UM	Type	FB BIT	Def	Min	Max	Acc	Mod
	4842	Alarm hi state		UINT32	32	0	0	0	ER	

This parameter displays the state of alarms 33...64 of the drive.

Bit	Description
0	1 = Min Speed active
1	1 = PLC 2 fault active
2	1 = PLC 3 fault active
3	1 = PLC 4 fault active
4	1 = PLC 5 fault active
5	1 = PLC 6 fault active
6	1 = PLC 7 fault active
7	1 = PLC 8 fault active
19	1 = Analog 1 Err fault active
20	1 = Analog 2 Err fault active
21	1 = Analog 3 Err fault active
22	1 = Analog 4 Err fault active

Menu	PAR	Description	UM	Type	FB BIT	Def	Min	Max	Acc	Mod
	6000	Null		UINT32	32	0	0	0	ER	

This signal forces the variable to the zero level (always disabled).

Menu	PAR	Description	UM	Type	FB BIT	Def	Min	Max	Acc	Mod
	6002	One		UINT32	32	1	1	1	ER	

This signal forces the variable to level one (always active).

Menu	PAR	Description	UM	Type	FB BIT	Def	Min	Max	Acc	Mod
	6004	Speed limit state		BIT	16	0	0	1	ER	

This signal is activated when the drive is in the speed limit condition.

Menu	PAR	Description	UM	Type	FB BIT	Def	Min	Max	Acc	Mod
	6006	Current limit state		BIT	16	0	0	1	ER	

This signal is activated when the drive is in the current limit condition.

C - Parameter List (Expert)

1 - MONITOR

1.1	250	Output current	A	FLOAT	16/32 0.0	0.0	0.0	R	VS
1.2	252	Output voltage	V	FLOAT	16/32 0.0	0.0	0.0	R	VS
1.3	254	Output frequency	Hz	FLOAT	16/32 0.0	0.0	0.0	R	VS
1.4	256	Output power	kW	FLOAT	16/32 0.0	0.0	0.0	R	VS
1.5	628	Ramp setpoint	rpm	INT16	16/32 0	0	0	R	VS
1.6	664	Speed setpoint	rpm	INT16	16/32 0	0	0	R	VS
1.7	260	Motor speed	rpm	INT16	16/32 0	0	0	R	VS
1.8	270	DC link voltage	V	FLOAT	16/32 0.0	0.0	0.0	ER	VS
1.9	272	Heatsink temperature	degC	INT16	16BIT 0	0	0	ER	VS
1.10	290	Motor temperature	degC	FLOAT	0.0	0.0	0.0	ER	VS
1.11	280	Torque current ref	A	FLOAT	16/32 0.0	0.0	0.0	ER	_S
1.12	282	Magnet current ref	A	FLOAT	16/32 0.0	0.0	0.0	ER	_S
1.13	284	Torque current	A	FLOAT	16/32 0.0	0.0	0.0	ER	VS
1.14	286	Magnet current	A	FLOAT	16/32 0.0	0.0	0.0	ER	VS
1.15	3212	Motor overload accum	perc	UINT16	16/32 0	0	100	ER	VS
1.16	368	Drive overload accum	perc	UINT16	16/32 0	0	100	ER	VS
1.17	3260	Bres overload accum	perc	UINT16	16/32 0	0	100	ER	VS
1.18	1066	Enable state mon		BIT	16BIT 0	0	1	R	VS
1.19	1068	Start state mon		BIT	16BIT 0	0	1	R	VS
1.20	1070	FastStop state mon		BIT	16BIT 0	0	1	R	VS
1.21	1100	Digital input mon		UINT16	16BIT 0	0	0	R	VS
1.22	1300	Digital output mon		UINT16	0	0	0	R	VS
1.23	1200	Digital input X mon		UINT16	16BIT 0	0	0	R	VS
1.24	1400	Digital output X mon		UINT16	0	0	0	R	VS

2 - DRIVE INFO

2.1	482	Drive size		UINT16	0	0	0	RS	VS
2.2	484	Drive family		ENUM	No power	0	0	RS	VS
				0	No power				
				1	380V..480V				
				2	500V..575V				
				3	690V				
				4	230V				
2.3	486	Drive region		ENUM	EU	0	1	R	VS
				0	EU				
				1	USA				
2.4	488	Drive cont current	A	FLOAT	CALCF	0.0	0.0	RZS	VS
2.5	490	Firmware ver.rel		UINT16	0	0	0	R	VS
2.6	496	Firmware type		UINT16	0	0	0	R	VS
2.7	504	Application ver.rel		UINT16	0	0	0	ER	VS
2.8	506	Application type		UINT16	0	0	0	ER	VS
2.9	508	Application subver		UINT16	0	0	0	ER	VS
2.10	518	Actual date time		UINT32	0	0	0	R	VS
2.11	510	Time drive power on	h.min	UINT32	0	0	0	ER	VS
2.12	512	Time drive enable	h.min	UINT32	0	0	0	ER	VS
2.13	514	Number power up		UINT16	0	0	0	ER	VS
2.14	516	Time fan on	h.min	UINT32	0	0	0	ER	VS
2.15	526	Power file ver.rel		UINT16	0	0	0	ER	VS
2.16	530	Slot1 card type		ENUM	None	0	0	R	VS
				0	None				

Menu	PAR	Description	UM	Type	FB BIT Def	Min	Max	Acc	Mod
					769				
					1793				
					2305				
					3329				
					4865				
					5633				
					6401				
					7681				
					4				
					260				
					516				
					255				
2.17	532	Slot2 card type		ENUM	None	0	0	R	VS
					0				
					769				
					1793				
					2305				
					3329				
					4865				
					5633				
					6401				
					7681				
					4				
					260				
					516				
					255				
2.18	534	Slot3 card type		ENUM	None	0	0	R	VS
					0				
					769				
					1793				
					2305				
					3329				
					4865				
					5633				
					6401				
					7681				
					4				
					260				
					516				
					255				

3 - STARTUP WIZARD

4 - DRIVE CONFIG

4.1	550	Save parameters		BIT	0	0	1	RW	VS
4.2	552	Regulation mode		ENUM	V/f control	0	2	RWZ	VS
					0				
					1				
					2				
4.3	554	Access mode		ENUM	Easy	0	1	RW	VS
					0				
					1				
4.4	556	Control mode select		ENUM	Ramp	0	2	ERWZ	_S
					0				
					1				
					2				
4.5	558	Application select		ENUM	None	0	2	ERWZ	VS
					0				
					1				

Menu	PAR	Description	UM	Type	FB BIT Def	Min	Max	Acc	Mod
				2	Application 2				
4.6	560	Mains voltage		ENUM	400 V	SIZE	SIZE	ERWZS	VS
				0	None				
				1	230 V				
				2	380 V				
				3	400 V				
				4	415 V				
				5	440 V				
				6	460 V				
				7	480 V				
				8	500 V				
				9	575 V				
				10	690 V				
4.7	586	DC supply		ENUM	None	0	7	ERWZS	VS
				0	None				
				1	540V(380-480V)				
				2	650V(380-480V)				
				3	750V(380-480V)				
				10	675V(690V)				
				11	810V(690V)				
				12	935V(690V)				
				13	1120V(690V)				
4.8	450	Undervoltage	V	FLOAT	CALCF	CALCF	CALCF	ERWZS	VS
4.9	562	Switching frequency		ENUM	SIZE	SIZE	SIZE	ERWS	VS
				0	1 kHz				
				1	2 kHz				
				2	4 kHz				
				3	6 kHz				
				4	8 kHz				
				5	10 kHz				
				6	12 kHz				
				7	16 kHz				
4.10	564	Ambient temperature		ENUM	40 degC	0	1	ERWZ	VS
				0	40 degC				
				1	50 degC				
4.11	566	Drive overload mode		ENUM	Light duty	1	2	ERWZ	VS
				1	Heavy duty				
				2	Light duty				
4.12	568	Switching freq mode		ENUM	Constant	0	1	ERWZS	VS
				0	Constant				
				1	Variable				
4.13	570	Password		UINT32	0	0	99999	ERW	VS
4.14	572	Application key		UINT32	0	0	4294967295	ERW	VS
4.15	574	Startup display		INT16	-1	-1	20000	ERW	VS
4.16	576	Display backlight		BIT	0	0	1	ERW	VS
4.17	578	Language select		ENUM	1	0	9	RWZ	VS
				0	English				
				1	Italian				
				2	French				
				3	German				
				4	Spanish				
				5	Polish				
				6	Romanian				
				7	Russian				
				8	Turkish				
				9	Portuguese				
4.18	580	Load default		BIT	0	0	1	RWZ	VS
4.19	590	Save par to keypad		BIT	0	0	1	RW	VS
4.20	592	Load par from keypad		BIT	0	0	1	RWZ	VS

Menu	PAR	Description	UM	Type	FB BIT Def	Min	Max	Acc	Mod
4.21	594	Keypad memory select		UINT16	1	1	5	ERW	VS

5 - REFERENCES

5.1	600	Dig ramp ref 1	rpm	INT16	16/32 0	CALCI	CALCI	RW	VS
5.2	602	Dig ramp ref 2	rpm	INT16	16/32 0	CALCI	CALCI	ERW	VS
5.3	604	Dig ramp ref 3	rpm	INT16	16/32 0	CALCI	CALCI	ERW	VS
5.4	610	Ramp ref 1 src		LINK	16/32 1500	0	16384	RW	VS
				L_MLTREF					
5.5	612	Ramp ref 2 src		LINK	16/32 602	0	16384	ERW	VS
				L_MLTREF					
5.6	614	Ramp ref 3 src		LINK	16/32 894	0	16384	ERW	VS
				L_MLTREF					
5.7	616	Ramp ref invert src		LINK	16BIT 1050	0	16384	ERW	VS
				L_DIGSEL2					
5.8	620	Ramp ref 1 mon	rpm	INT16	0	0	0	R	VS
5.9	622	Ramp ref 2 mon	rpm	INT16	0	0	0	ER	VS
5.10	624	Ramp ref 3 mon	rpm	INT16	0	0	0	ER	VS
5.11	634	Ramp ref top lim	rpm	INT32	0	0	CALCI	ERWZ	VS
5.12	636	Ramp ref bottom lim	rpm	INT32	0	0	CALCI	ERWZ	VS
5.13	630	Reference skip set1	rpm	INT16	0	0	CALCI	ERW	VS
5.14	632	Reference skip band1	rpm	INT16	0	0	CALCI	ERW	VS
5.15	682	Reference skip set2	rpm	INT16	0	0	CALCI	RW	VS
5.16	684	Reference skip band2	rpm	INT16	0	0	CALCI	RW	VS
5.17	686	Reference skip set3	rpm	INT16	0	0	CALCI	RW	VS
5.18	688	Reference skip band3	rpm	INT16	0	0	CALCI	RW	VS
5.19	640	Dig speed ref 1	rpm	INT16	16/32 0	CALCI	CALCI	ERW	VS
5.20	642	Dig speed ref 2	rpm	INT16	16/32 0	CALCI	CALCI	ERW	VS
5.21	650	Speed ref 1 src		LINK	16/32 640	0	16384	ERW	VS
				L_MLTREF					
5.22	652	Speed ref 2 src		LINK	16/32 642	0	16384	ERW	VS
				L_MLTREF					
5.23	654	Speed ref invert src		LINK	16BIT 6000	0	16384	ERWZ	VS
				L_DIGSEL2					
5.24	660	Speed ref 1 mon	rpm	INT16	0	0	0	ER	VS
5.25	662	Speed ref 2 mon	rpm	INT16	0	0	0	ER	VS
5.26	670	Speed ref top lim	rpm	INT32	CALCI	0	CALCI	ERWZ	VS
5.27	672	Speed ref bottom lim	rpm	INT32	CALCI	CALCI	0	ERWZ	VS
5.28	680	Full scale speed	rpm	INT16	CALCI	50	32000	RWZ	VS

6 - RAMPS

6.1	700	Acceleration time 0	s	FLOAT	10.0	0.01	1000.0	RW	VS
6.2	702	Deceleration time 0	s	FLOAT	10.0	0.01	1000.0	RW	VS
6.3	704	Acceleration time 1	s	FLOAT	10.0	0.01	1000.0	ERW	VS
6.4	706	Deceleration time 1	s	FLOAT	10.0	0.01	1000.0	ERW	VS
6.5	708	Acceleration time 2	s	FLOAT	10.0	0.01	1000.0	ERW	VS
6.6	710	Deceleration time 2	s	FLOAT	10.0	0.01	1000.0	ERW	VS
6.7	712	Acceleration time 3	s	FLOAT	10.0	0.01	1000.0	ERW	VS
6.8	714	Deceleration time 3	s	FLOAT	10.0	0.01	1000.0	ERW	VS
6.9	720	Ramp type		ENUM	Linear	0	3	ERWZ	VS
				0	Linear				
				1	S-Shape				
				2	Bypass				
				3	Off				

Menu	PAR	Description	UM	Type	FB BIT Def	Min	Max	Acc	Mod
6.10	722	Multi ramp sel 0 src		LINK	16BIT 6000	0	16384	ERW	VS
				L_DIGSEL2					
6.11	724	Multi ramp sel 1 src		LINK	16BIT 6000	0	16384	ERW	VS
				L_DIGSEL2					
6.12	726	Multi ramp sel mon		UINT16	0	0	3	ER	VS
6.13	730	Accel jerk time 0	s	FLOAT	1.0	0.02	10.0	ERW	VS
6.14	732	Decel jerk time 0	s	FLOAT	1.0	0.02	10.0	ERW	VS
6.15	734	Accel jerk time 1	s	FLOAT	1.0	0.02	10.0	ERW	VS
6.16	736	Decel jerk time 1	s	FLOAT	1.0	0.02	10.0	ERW	VS
6.17	738	Accel jerk time 2	s	FLOAT	1.0	0.02	10.0	ERW	VS
6.18	740	Decel jerk time 2	s	FLOAT	1.0	0.02	10.0	ERW	VS
6.19	742	Accel jerk time 3	s	FLOAT	1.0	0.02	10.0	ERW	VS
6.20	744	Decel jerk time 3	s	FLOAT	1.0	0.02	10.0	ERW	VS
6.21	750	Ramp in zero src		LINK	16BIT 6000	0	16384	ERW	VS
				L_DIGSEL2					
6.22	752	Ramp out zero src		LINK	16BIT 6000	0	16384	ERW	VS
				L_DIGSEL2					
6.23	754	Ramp freeze src		LINK	16BIT 3480	0	16384	ERW	VS
				L_DIGSEL2					

7 - MULTI REFERENCE

7.1	800	Multi reference 0	rpm	INT16	16/32 0	CALCI	CALCI	RW	VS
7.2	802	Multi reference 1	rpm	INT16	16/32 0	CALCI	CALCI	RW	VS
7.3	804	Multi reference 2	rpm	INT16	0	CALCI	CALCI	RW	VS
7.4	806	Multi reference 3	rpm	INT16	0	CALCI	CALCI	RW	VS
7.5	808	Multi reference 4	rpm	INT16	0	CALCI	CALCI	RW	VS
7.6	810	Multi reference 5	rpm	INT16	0	CALCI	CALCI	RW	VS
7.7	812	Multi reference 6	rpm	INT16	0	CALCI	CALCI	RW	VS
7.8	814	Multi reference 7	rpm	INT16	0	CALCI	CALCI	RW	VS
7.9	816	Multi reference 8	rpm	INT16	0	CALCI	CALCI	ERW	VS
7.10	818	Multi reference 9	rpm	INT16	0	CALCI	CALCI	ERW	VS
7.11	820	Multi reference 10	rpm	INT16	0	CALCI	CALCI	ERW	VS
7.12	822	Multi reference 11	rpm	INT16	0	CALCI	CALCI	ERW	VS
7.13	824	Multi reference 12	rpm	INT16	0	CALCI	CALCI	ERW	VS
7.14	826	Multi reference 13	rpm	INT16	0	CALCI	CALCI	ERW	VS
7.15	828	Multi reference 14	rpm	INT16	0	CALCI	CALCI	ERW	VS
7.16	830	Multi reference 15	rpm	INT16	0	CALCI	CALCI	ERW	VS
7.17	832	Multi ref 0 src		LINK	16/32 800	0	16384	RW	VS
				L_MLTREF					
7.18	834	Multi ref 1 src		LINK	16/32 802	0	16384	RW	VS
				L_MLTREF					
7.19	840	Multi ref sel 0 src		LINK	16BIT 6000	0	16384	RW	VS
				L_DIGSEL2					
7.20	842	Multi ref sel 1 src		LINK	16BIT 6000	0	16384	RW	VS
				L_DIGSEL2					
7.21	844	Multi ref sel 2 src		LINK	16BIT 6000	0	16384	RW	VS
				L_DIGSEL2					
7.22	846	Multi ref sel 3 src		LINK	16BIT 6000	0	16384	ERW	VS
				L_DIGSEL2					
7.23	850	Multi ref sel mon		UINT16	0	0	15	R	VS
7.24	852	Multi ref out mon	rpm	INT16	16/32 0	0	0	R	VS

8 - MOTORPOTENTIOMETER

Menu	PAR	Description	UM	Type	FB BIT Def	Min	Max	Acc	Mod
8.1	870	Mpot setpoint	rpm	INT16	16/32 0	CALCI	CALCI	R	VS
8.2	872	Mpot acceleration	s	FLOAT	5.0	0.01	1000.0	RW	VS
8.3	874	Mpot deceleration	s	FLOAT	5.0	0.01	1000.0	RW	VS
8.4	876	Mpot top lim	rpm	INT16	CALCI	CALCI	CALCI	ERW	VS
8.5	878	Mpot bottom lim	rpm	INT16	0	CALCI	CALCI	ERW	VS
8.6	880	Mpot init cfg		ENUM	Zero	0	3	ERW	VS
				0	Last Power Off				
				1	Zero				
				2	Lower Limit				
				3	Upper Limit				
8.7	882	Mpot preset cfg		ENUM	None	0	11	ERW	VS
				0	None				
				1	Input=0				
				2	Input=low lim				
				3	Input&ref=0				
				4	Input&ref=low				
				5	Output=0				
				6	Output=low lim				
				7	Output&ref=0				
				8	Output&ref=low				
				9	Input=upp lim				
				10	Input&ref=upp				
				11	Freeze input				
8.8	884	Mpot up src		LINK	16BIT 6000	0	16384	RW	VS
				L_DIGSEL2					
8.9	886	Mpot down src		LINK	16BIT 6000	0	16384	RW	VS
				L_DIGSEL2					
8.10	888	Mpot invert src		LINK	16BIT 6000	0	16384	ERW	VS
				L_DIGSEL2					
8.11	890	Mpot preset src		LINK	16BIT 6000	0	16384	ERW	VS
				L_DIGSEL2					
8.12	892	Mpot mode		ENUM	Fine&Last val0		3	ERW	VS
				0	Ramp&Last val				
				1	Ramp&Follow				
				2	Fine&Last val				
				3	Fine&Follow				
8.13	894	Mpot output mon	rpm	INT16	16/32 0	0	0	ER	VS

9 - JOG FUNCTION

9.1	910	Jog setpoint	rpm	INT16	0	CALCI	CALCI	RW	VS
9.2	912	Jog acceleration	s	FLOAT	5.0	0.01	1000.0	RW	VS
9.3	914	Jog deceleration	s	FLOAT	5.0	0.01	1000.0	RW	VS
9.4	916	Jog cmd + src		LINK	16BIT 6000	0	16384	RW	VS
				L_DIGSEL2					
9.5	918	Jog cmd - src		LINK	16BIT 6000	0	16384	RW	VS
				L_DIGSEL2					
9.6	920	Jog output mon	rpm	INT16	16/32 0	0	0	ER	VS

10 - MONITOR FUNCTION

10.1	930	Reference 0 thr	rpm	INT16	30	0	CALCI	RW	VS
10.2	932	Reference 0 delay	ms	UINT16	400	0	10000	RW	VS
10.3	940	Speed 0 thr	rpm	INT16	30	0	CALCI	RW	VS
10.4	942	Speed 0 delay	ms	UINT16	400	0	10000	RW	VS
10.5	950	Speed threshold 1	rpm	INT32	0	CALCI	CALCI	RW	VS
10.6	952	Speed threshold 2	rpm	INT32	0	CALCI	CALCI	RW	VS

Menu	PAR	Description	UM	Type	FB BIT Def	Min	Max	Acc	Mod
10.7	954	Speed threshold dly	ms	UINT16	0	0	50000	RW	VS
10.8	960	Set speed ref src		LINK	16/32 628	0	16384	ERW	VS
				L_CMP					
10.9	962	Set speed error	rpm	INT16	100	0	CALCI	RW	VS
10.10	964	Set speed delay	ms	UINT16	0	0	50000	RW	VS
10.11	968	Dig set speed ref	rpm	INT16	16/32 0	CALCI	CALCI	ERW	VS
10.12	970	Speed threshold 3	rpm	INT32	0	0	CALCI	RW	VS
10.13	972	Speed thr hysteresis	rpm	INT16	0	0	CALCI	RW	VS
10.14	980	Current threshold	perc	INT16	100	0	200	RW	VS
10.15	982	Current thr hyster	perc	INT16	0	0	100	RW	VS

11 - COMMANDS

11.1	1000	Commands remote sel		ENUM	Terminal	0	1	RWZ	VS
				0	Terminal				
				1	Digital				
11.2	1002	Commands local sel		ENUM	Keypad	0	1	ERWZ	VS
				0	Terminal				
				2	Keypad				
11.3	1004	Enable/disable mode		ENUM	Stop/FS&Spd=0	0	3	ERW	VS
				0	Off				
				1	Stop/FS&Spd=0				
				2	Stop&Spd=0				
				3	FS&Spd=0				
11.4	1006	Speed 0 disable dly	ms	UINT16	1000	0	10000	ERW	VS
11.5	1008	Stop key mode		ENUM	Inactive	0	1	ERW	VS
				0	Inactive				
				1	EmgStop&Alarm				
11.6	1010	Commands safe start		BIT	1	0	1	ERW	VS
11.7	1012	Dig local/remote		ENUM	16BIT Remote	0	1	ERW	VS
				0	Local				
				1	Remote				
11.8	1014	Local/remote src		LINK	16BIT 1012	0	16384	ERW	VS
				L_DIGSEL3					
11.9	1016	Terminal Start src		LINK	16BIT 1048	0	16384	ERW	VS
				L_DIGSEL2					
11.10	1018	Digital Enable src		LINK	16BIT 6000	0	16384	ERW	VS
				L_DIGSEL2					
11.11	1020	Digital Start src		LINK	16BIT 6000	0	16384	ERW	VS
				L_DIGSEL2					
11.12	1022	FastStop src		LINK	16BIT 6000	0	16384	ERW	VS
				L_DIGSEL2					
11.13	1024	Enable cmd mon		BIT	16BIT 0	0	1	R	VS
11.14	1026	Start cmd mon		BIT	16BIT 0	0	1	R	VS
11.15	1028	FastStop cmd mon		BIT	16BIT 0	0	1	R	VS
11.16	1040	FR mode		ENUM	Two wire	0	2	ERWZ	VS
				0	Normal				
				1	Two wire				
				2	Three wire				
11.17	1042	FR forward src		LINK	16BIT 1112	0	16384	ERW	VS
				L_DIGSEL2					
11.18	1044	FR reverse src		LINK	16BIT 1114	0	16384	ERW	VS
				L_DIGSEL2					
11.19	1046	FR *stop src		LINK	16BIT 6000	0	16384	ERW	VS
				L_DIGSEL2					
11.20	1048	FR start mon		BIT	16BIT 0	0	1	ER	VS

Menu	PAR	Description	UM	Type	FB BIT Def	Min	Max	Acc	Mod
11.21	1050	FR reverse mon		BIT	16BIT 0	0	1	ER	VS
11.22	1052	FR cmd mon		UINT16	0	0	0	ER	VS

12 - DIGITAL INPUTS

12.1	1132	Dig inp 1 inversion		BIT	0	0	1	RW	VS
12.2	1134	Dig inp 2 inversion		BIT	0	0	1	RW	VS
12.3	1136	Dig inp 3 inversion		BIT	0	0	1	RW	VS
12.4	1138	Dig inp 4 inversion		BIT	0	0	1	RW	VS
12.5	1140	Dig inp 5 inversion		BIT	0	0	1	RW	VS
12.6	1150	Digital input E dest		ILINK	0	0	0	ER	VS
12.7	1152	Digital input 1 dest		ILINK	0	0	0	ER	VS
12.8	1154	Digital input 2 dest		ILINK	0	0	0	ER	VS
12.9	1156	Digital input 3 dest		ILINK	0	0	0	ER	VS
12.10	1158	Digital input 4 dest		ILINK	0	0	0	ER	VS
12.11	1160	Digital input 5 dest		ILINK	0	0	0	ER	VS
12.12	1240	Dig inp 1X inversion		BIT	0	0	1	RW	VS
12.13	1242	Dig inp 2X inversion		BIT	0	0	1	RW	VS
12.14	1244	Dig inp 3X inversion		BIT	0	0	1	RW	VS
12.15	1246	Dig inp 4X inversion		BIT	0	0	1	RW	VS
12.16	1248	Dig inp 5X inversion		BIT	0	0	1	RW	VS
12.17	1250	Dig inp 6X inversion		BIT	0	0	1	RW	VS
12.18	1252	Dig inp 7X inversion		BIT	0	0	1	RW	VS
12.19	1254	Dig inp 8X inversion		BIT	0	0	1	RW	VS
12.20	1270	Dig input 1X dest		ILINK	0	0	0	ER	VS
12.21	1272	Dig input 2X dest		ILINK	0	0	0	ER	VS
12.22	1274	Dig input 3X dest		ILINK	0	0	0	ER	VS
12.23	1276	Dig input 4X dest		ILINK	0	0	0	ER	VS
12.24	1278	Dig input 5X dest		ILINK	0	0	0	ER	VS
12.25	1280	Dig input 6X dest		ILINK	0	0	0	ER	VS
12.26	1282	Dig input 7X dest		ILINK	0	0	0	ER	VS
12.27	1284	Dig input 8X dest		ILINK	0	0	0	ER	VS

13 - DIGITAL OUTPUTS

13.1	1310	Digital output 1 src		LINK	16BIT 1062	0	16384	RW	VS
				L_DIGSEL1					
13.2	1312	Digital output 2 src		LINK	16BIT 1064	0	16384	RW	VS
				L_DIGSEL1					
13.3	1314	Digital output 3 src		LINK	16BIT 946	0	16384	RW	VS
				L_DIGSEL1					
13.4	1316	Digital output 4 src		LINK	16BIT 936	0	16384	RW	VS
				L_DIGSEL1					
13.5	1330	Dig out 1 inversion		BIT	0	0	1	RW	VS
13.6	1332	Dig out 2 inversion		BIT	0	0	1	RW	VS
13.7	1334	Dig out 3 inversion		BIT	0	0	1	RW	VS
13.8	1336	Dig out 4 inversion		BIT	0	0	1	RW	VS
13.9	1410	Dig output 1X src		LINK	16BIT 6000	0	16384	RW	VS
				L_DIGSEL1					
13.10	1412	Dig output 2X src		LINK	16BIT 6000	0	16384	RW	VS
				L_DIGSEL1					
13.11	1414	Dig output 3X src		LINK	16BIT 6000	0	16384	RW	VS
				L_DIGSEL1					
13.12	1416	Dig output 4X src		LINK	16BIT 6000	0	16384	RW	VS
				L_DIGSEL1					

Menu	PAR	Description	UM	Type	FB BIT Def	Min	Max	Acc	Mod
13.13	1418	Dig output 5X src		LINK	16BIT 6000	0	16384	RW	VS
				L_DIGSEL1					
13.14	1420	Dig output 6X src		LINK	16BIT 6000	0	16384	RW	VS
				L_DIGSEL1					
13.15	1422	Dig output 7X src		LINK	16BIT 6000	0	16384	RW	VS
				L_DIGSEL1					
13.16	1424	Dig output 8X src		LINK	16BIT 6000	0	16384	RW	VS
				L_DIGSEL1					
13.17	1426	Dig output 9X src		LINK	16BIT 6000	0	16384	RW	VS
				L_DIGSEL1					
13.18	1430	Dig out 1X inversion		BIT	0	0	1	RW	VS
13.19	1432	Dig out 2X inversion		BIT	0	0	1	RW	VS
13.20	1434	Dig out 3X inversion		BIT	0	0	1	RW	VS
13.21	1436	Dig out 4X inversion		BIT	0	0	1	RW	VS
13.22	1438	Dig out 5X inversion		BIT	0	0	1	RW	VS
13.23	1440	Dig out 6X inversion		BIT	0	0	1	RW	VS
13.24	1442	Dig out 7X inversion		BIT	0	0	1	RW	VS
13.25	1444	Dig out 8X inversion		BIT	0	0	1	RW	VS
13.26	1446	Dig out 9X inversion		BIT	0	0	1	RW	VS

14 - ANALOG INPUTS

14.1	1500	Analog input 1 mon	cnt	INT16	16/32 0	-16384	16384	R	VS
14.2	1502	Analog inp 1 type		ENUM	-10V..+10V	0	2	RW	VS
				0	-10V..+10V				
				1	0.20mA , 0.10V				
				2	4..20mA				
14.3	1504	Analog inp 1 scale		FLOAT	1.0	-10.0	10.0	RW	VS
14.4	1506	An inp 1 offset tune		BIT	0	0	1	RW	VS
14.5	1508	An inp 1 gain tune		BIT	0	0	1	RW	VS
14.6	1510	Analog inp 1 filter	ms	FLOAT	10.0	1.0	1000.0	ERW	VS
14.7	1512	Analog inp 1 top	cnt	INT16	16384	-32768	+32767	ERW	VS
14.8	1514	Analog inp 1 bottom	cnt	INT16	-16384	-32768	+32767	ERW	VS
14.9	1516	Analog inp 1 offset	cnt	INT16	0	-32768	+32767	ERW	VS
14.10	1518	Analog inp 1 gain		FLOAT	1.0	-10.0	10.0	ERW	VS
14.11	1520	Analog inp 1 thr	cnt	INT16	0	-16384	+16384	ERW	VS
14.12	1522	An inp 1 deadband	perc	FLOAT	0.0	0.0	100.0	ERW	VS
14.13	1524	An inp 1 alt value	cnt	INT16	16/32 0	-16384	16384	ERW	VS
14.14	1526	An inp 1 sign src		LINK	16BIT 6000	0	16384	ERW	VS
				L_DIGSEL2					
14.15	1528	An inp 1 alt sel src		LINK	16BIT 6000	0	16384	ERW	VS
				L_DIGSEL2					
14.16	1532	Analog input 1 dest		ILINK	0	0	0	ER	VS
14.17	1550	Analog input 2 mon	cnt	INT16	16/32 0	-16384	16384	R	VS
14.18	1552	Analog inp 2 type		ENUM	-10V..+10V	0	2	RW	VS
				0	-10V..+10V				
				1	0.20mA , 0.10V				
				2	4..20mA				
14.19	1554	Analog inp 2 scale		FLOAT	1.0	-10.0	10.0	RW	VS
14.20	1556	An inp 2 offset tune		BIT	0	0	1	RW	VS
14.21	1558	An inp 2 gain tune		BIT	0	0	1	RW	VS
14.22	1560	Analog inp 2 filter	ms	FLOAT	10.0	1.0	1000.0	ERW	VS
14.23	1562	Analog inp 2 top	cnt	INT16	16384	-32768	+32767	ERW	VS
14.24	1564	Analog inp 2 bottom	cnt	INT16	-16384	-32768	+32767	ERW	VS
14.25	1566	Analog inp 2 offset	cnt	INT16	0	-32768	+32767	ERW	VS

Menu	PAR	Description	UM	Type	FB BIT Def	Min	Max	Acc	Mod
14.26	1568	Analog inp 2 gain		FLOAT	1.0	-10.0	10.0	ERW	VS
14.27	1570	Analog inp 2 thr	cnt	INT16	0	-16384	+16384	ERW	VS
14.28	1572	An inp 2 deadband	perc	FLOAT	0.0	0.0	100.0	ERW	VS
14.29	1574	An inp 2 alt value	cnt	INT16	16/32 0	-16384	16384	ERW	VS
14.30	1576	An inp 2 sign src		LINK	16BIT 6000	0	16384	ERW	VS
				L_DIGSEL2					
14.31	1578	An inp 2 alt sel src		LINK	16BIT 6000	0	16384	ERW	VS
				L_DIGSEL2					
14.32	1582	Analog input 2 dest		ILINK	0	0	0	ER	VS
14.33	1600	Analog input 1X mon	cnt	INT16	16/32 0	-16384	16384	R	VS
14.34	1602	Analog inp 1X type		ENUM	-10V..+10V	0	6	RW	VS
				0	-10V..+10V				
				1	0..10V				
				2	0..20mA				
				3	4..20mA				
				4	PT1000				
				5	NI1000				
				6	PT100				
14.35	1604	Analog inp 1X scale		FLOAT	1.0	-10.0	10.0	RW	VS
14.36	1606	An inp 1Xoffset tune		BIT	0	0	1	RW	VS
14.37	1608	An inp 1X gain tune		BIT	0	0	1	RW	VS
14.38	1612	Analog inp 1X top	cnt	INT16	16384	-32768	+32767	ERW	VS
14.39	1614	Analog inp 1X bottom	cnt	INT16	-16384	-32768	+32767	ERW	VS
14.40	1616	Analog inp 1X offset	cnt	INT16	0	-32768	+32767	ERW	VS
14.41	1618	Analog inp 1X gain		FLOAT	1.0	-10.0	10.0	ERW	VS
14.42	1626	An inp 1X sign src		LINK	16BIT 6000	0	16384	ERW	VS
				L_DIGSEL2					
14.43	1632	Analog input 1X dest		ILINK	0	0	0	ER	VS
14.44	1650	Analog input 2X mon	cnt	INT16	16/32 0	-16384	16384	R	VS
14.45	1652	Analog inp 2X type		ENUM	-10V..+10V	0	6	RW	VS
				0	-10V..+10V				
				1	0..10V				
				2	0..20mA				
				3	4..20mA				
				4	PT1000				
				5	NI1000				
				6	PT100				
14.46	1654	Analog inp 2X scale		FLOAT	1.0	-10.0	10.0	RW	VS
14.47	1656	An inp 2Xoffset tune		BIT	0	0	1	RW	VS
14.48	1658	An inp 2X gain tune		BIT	0	0	1	RW	VS
14.49	1662	Analog inp 2X top	cnt	INT16	16384	-32768	+32767	ERW	VS
14.50	1664	Analog inp 2X bottom	cnt	INT16	-16384	-32768	+32767	ERW	VS
14.51	1666	Analog inp 2X offset	cnt	INT16	0	-32768	+32767	ERW	VS
14.52	1668	Analog inp 2X gain		FLOAT	1.0	-10.0	10.0	ERW	VS
14.53	1676	An inp 2X sign src		LINK	16BIT 6000	0	16384	ERW	VS
				L_DIGSEL2					
14.54	1682	Analog input 2X dest		ILINK	0	0	0	ER	VS

15 - ANALOG OUTPUTS

15.1	1800	Analog out 1 src		LINK	16/32 6000	0	16384	RW	VS
				L_ANOUT					
15.2	1802	Analog out 2 src		LINK	16/32 6000	0	16384	RW	VS
				L_ANOUT					
15.3	1808	Analog out 1 scale		FLOAT	1.0	-10.0	10.0	RW	VS
15.4	1810	Analog out 2 scale		FLOAT	1.0	-10.0	10.0	RW	VS

Menu	PAR	Description	UM	Type	FB BIT Def	Min	Max	Acc	Mod
15.5	1816	Analog out 1 mon	cnt	INT16	0	0	0	ER	VS
15.6	1818	Analog out 2 mon	cnt	INT16	0	0	0	ER	VS
15.7	1824	An out 1 absolute		ENUM	Disable	0	1	ERW	VS
				0	Disable				
				1	Enable				
15.8	1826	An out 2 absolute		ENUM	Disable	0	1	ERW	VS
				0	Disable				
				1	Enable				
15.9	1832	Analog out 1 min	cnt	INT16	-16384	-32768	+32767	ERW	VS
15.10	1834	Analog out 1 max	cnt	INT16	16384	-32768	+32767	ERW	VS
15.11	1840	Analog out 2 min	cnt	INT16	-16384	-32768	+32767	ERW	VS
15.12	1842	Analog out 2 max	cnt	INT16	16384	-32768	+32767	ERW	VS
15.13	1848	Analog out 2 type		ENUM	-10V..+10V	0	2	ERW	VS
				0	0..20mA				
				1	4..20mA				
				2	-10V..+10V				
15.14	1850	Analog out 1X src		LINK	16/32 6000	0	16384	RW	VS
				L_ANOUT					
15.15	1852	Analog out 2X src		LINK	16/32 6000	0	16384	RW	VS
				L_ANOUT					
15.16	1858	Analog out 1X scale		FLOAT	1.0	-10.0	10.0	RW	VS
15.17	1860	Analog out 2X scale		FLOAT	1.0	-10.0	10.0	RW	VS
15.18	1866	Analog out 1X mon	cnt	INT16	0	0	0	ER	VS
15.19	1868	Analog out 2X mon	cnt	INT16	0	0	0	ER	VS
15.20	1874	An out 1X absolute		ENUM	Disable	0	1	ERW	VS
				0	Disable				
				1	Enable				
15.21	1876	An out 2X absolute		ENUM	Disable	0	1	ERW	VS
				0	Disable				
				1	Enable				
15.22	1882	Analog out 1X min	cnt	INT16	0	-32768	+32767	ERW	VS
15.23	1884	Analog out 1X max	cnt	INT16	16384	-32768	+32767	ERW	VS
15.24	1886	Analog out 1X type		ENUM	0..10V	0	3	ERW	VS
				0	0..20mA				
				1	4..20mA				
				2	-10V..+10V				
				3	0..10V				
15.25	1890	Analog out 2X min	cnt	INT16	0	-32768	+32767	ERW	VS
15.26	1892	Analog out 2X max	cnt	INT16	16384	-32768	+32767	ERW	VS
15.27	1898	Analog out 2X type		ENUM	0..10V	0	3	ERW	VS
				0	0..20mA				
				1	4..20mA				
				2	-10V..+10V				
				3	0..10V				

16 - MOTOR DATA

16.1	2000	Rated voltage	V	FLOAT	SIZE	50.0	690.0	RWZS	VS
16.2	2002	Rated current	A	FLOAT	SIZE	1.0	2200.0	RWZS	VS
16.3	2004	Rated speed	rpm	FLOAT	SIZE	10.0	32000.0	RWZS	VS
16.4	2006	Rated frequency	Hz	FLOAT	SIZE	10.0	1000.0	RWZS	VS
16.5	2008	Pole pairs		UINT16	SIZE	1	20	RWZS	VS
16.6	2010	Rated power	kW	FLOAT	SIZE	0.1	1500.0	RWZS	VS
16.7	2012	Rated power factor		FLOAT	SIZE	0.6	0.95	RWZS	VS
16.8	2020	Take parameters		BIT	0	0	1	RWZ	VS
16.9	2022	Autotune rotation		BIT	0	0	1	RWZ	VS

Menu	PAR	Description	UM	Type	FB BIT Def	Min	Max	Acc	Mod
16.10	2024	Autotune still		BIT	0	0	1	RWZ	VS
16.11	2026	Autotune mode		ENUM	Reduced	0	1	ERWZ	VS
				0	Reduced				
				1	Extended				
16.12	2028	Take par status		ENUM	Required	0	0	R	VS
				0	Required				
				1	Done				
16.13	2030	Autotune status		ENUM	Required	0	0	R	VS
				0	Required				
				1	Done				
16.14	2050	Measured RS	ohm	FLOAT	CALCF	0.0005	200.0	ERWS	VS
16.15	2052	Measured DTL	V	FLOAT	0.0	0.0	100.0	ERWS	VS
16.16	2054	Measured DTS	V/A	FLOAT	0.0	0.0	100.0	ERWS	VS
16.17	2056	Measured Lsig	mH	FLOAT	CALCF	0.01	200.0	ERWS	VS
16.18	2058	Measured ImN	A	FLOAT	CALCF	0.1	1500.0	ERWS	VS
16.19	2060	Measured ImX	A	FLOAT	CALCF	0.0	0.0	ERWS	VS
16.20	2062	Measured FlxN	Wb	FLOAT	CALCF	0.05	10.0	ERWS	VS
16.21	2064	Measured FlxX	Wb	FLOAT	CALCF	0.0	0.0	ERWS	VS
16.22	2066	Measured P1		FLOAT	0.5	0.0	1.0	ERWS	VS
16.23	2068	Measured P2		FLOAT	9.0	3.0	18.0	ERWS	VS
16.24	2070	Measured P3		FLOAT	0.87	0.0	1.0	ERWS	VS
16.25	2072	Measured Rr	ohm	FLOAT	CALCF	0.0005	200.0	ERWS	VS
16.26	2078	Take tune parameters		BIT	0	0	1	ERWZ	VS

18 - SPEED REG GAINS

18.1	2200	Speed reg P1 gain	perc	INT16	100	0	1000	RW	_S
18.2	2202	Speed reg I1 gain	perc	INT16	100	0	1000	RW	_S
18.3	2204	Speed reg P2 gain	perc	INT16	100	0	1000	ERW	_S
18.4	2206	Speed reg I2 gain	perc	INT16	100	0	1000	ERW	_S
18.5	2216	Gain adapt src		LINK	16/32 664	0	16384	ERW	_S
				L_REF					
18.6	2218	Gain adp spd thr1_2	perc	FLOAT	0.0	0.0	100.0	ERW	_S
18.7	2220	Gain adp spd band1_2	perc	FLOAT	0.0	0.0	100.0	ERW	_S
18.8	2226	Gain 0 enable		ENUM	Disable	0	1	ERW	_S
				0	Disable				
				1	Enable				
18.9	2228	Speed reg P0 gain	perc	INT16	100	0	1000	ERW	_S
18.10	2230	Speed reg I0 gain	perc	INT16	100	0	1000	ERW	_S
18.11	2232	Spd reg P gain Inuse	perc	INT16	16/32 100	0	1000	ER	_S
18.12	2234	Spd reg I gain Inuse	perc	INT16	16/32 100	0	1000	ER	_S
18.13	2236	Speed reg P gain	N/rpm	FLOAT	CALCF	0.0	500.0	ERWS	_S
18.14	2238	Speed reg I time	ms	FLOAT	CALCF	1.0	5000.0	ERWS	_S
18.15	2240	Inertia	kgm2	FLOAT	SIZE	0.001	100.0	RWZS	_S
18.16	2242	Bandwidth	rad/s	FLOAT	SIZE	1.0	500.0	RWZS	_S

19 - REGULATOR PARAM

19.1	2250	Current reg P gain	V/A	FLOAT	CALCF	0.0	0.0	ERWS	_S
19.2	2252	Current reg I time	ms	FLOAT	CALCF	0.01	10000.0	ERWS	_S
19.3	2260	Flux reg P gain	A/Wb	FLOAT	CALCF	0.0	0.0	ERWS	_S
19.4	2262	Flux reg I time	ms	FLOAT	CALCF	0.1	10000.0	ERWS	_S
19.5	2264	Flux reg P gain OL	A/Wb	FLOAT	CALCF	0.0	0.0	ERWS	_S
19.6	2266	Flux reg I time OL	ms	FLOAT	CALCF	0.1	30000.0	ERWS	_S
19.7	2270	Voltage reg P gain	Wb/V	FLOAT	CALCF	0.0	0.0	ERWS	_S

Menu	PAR	Description	UM	Type	FB BIT Def	Min	Max	Acc	Mod
19.8	2272	Voltage reg I time	s	FLOAT	CALCF	0.1	100.0	ERWS	_S
19.9	2280	Dead time limit	V	FLOAT	SIZE	0.0	50.0	ERWS	VS
19.10	2282	Dead time slope	V/A	FLOAT	SIZE	0.0	200.0	ERWS	VS
19.11	2290	Voltage base	V	FLOAT	CALCF	50.0	690.0	ERWS	_S
19.12	2292	Voltage margin	perc	FLOAT	5.0	0.0	10.0	ERWS	_S
19.13	2300	Minimum speed OL	rpm	INT16	30	0	CALCI	ERW	_S
19.14	2302	Min speed delay OL	ms	UINT16	200	0	5000	ERW	_S
19.15	2304	Speed filter OL	ms	FLOAT	5.0	0.1	20.0	ERWZ	_S
19.16	2306	Flux observe gain OL		FLOAT	250.0	10.0	5000.0	ERW	_S
19.17	2308	OverFlux perc	perc	FLOAT	100.0	100.0	140.0	ERW	_S
19.18	2310	Flux weakening OL		ENUM	Enable	0	1	ERWZ	_S
				0	Disable				
				1	Enable				
19.19	2312	OverFlux spd thr	rpm	FLOAT	400	10.0	1000.0	ERW	_S
19.20	2314	Flux step		FLOAT	20.0	1	2000	ERW	_S
19.21	2320	Magnetization time	ms	UINT16	256	128	4096	ERWZ	VS

21 - VF PARAMETERS

21.1	2400	Voltage flux boost	perc	FLOAT	0.0	0.0	15.0	RWS	V_
21.2	2402	Voltage boost gain	V/A	FLOAT	0.0	0.0	0.0	ERWS	V_
21.3	2404	Voltage torque boost		ENUM	Disable	0	1	ERWZ	V_
				0	Disable				
				1	Enable				
21.4	2406	Vf voltage	V	FLOAT	CALCF	10.0	690.0	ERWZS	V_
21.5	2408	Vf frequency	Hz	FLOAT	CALCF	10.0	2000.0	ERWZS	V_
21.6	2410	Vf voltage 1	V	FLOAT	CALCF	CALCF	CALCF	ERWZS	V_
21.7	2412	Vf frequency 1	Hz	FLOAT	CALCF	0.0	CALCF	ERWZS	V_
21.8	2414	Vf voltage 0	V	FLOAT	CALCF	0.0	CALCF	ERWZS	V_
21.9	2430	Vf shape		ENUM	Quadratic	0	2	ERWZS	V_
				0	Linear				
				1	Custom				
				2	Quadratic				
21.10	2440	Slip comp	Hz	FLOAT	CALCF	0.0	10.0	RWS	V_
21.11	2442	Slip comp filter	ms	UINT16	200	50	5000	ERW	V_
21.12	2444	Slip comp mode		ENUM	Open loop	0	1	ERWZ	V_
				0	Open loop				
				1	Closed loop				
21.13	2446	Slip P gain	perc	FLOAT	1.0	0.0	100.0	ERWS	V_
21.14	2448	Slip I gain	perc	FLOAT	1.5	0.0	100.0	ERWS	V_
21.15	2460	Vfcurrent lim P gain	Hz/A	FLOAT	CALCF	0.0	1000.0	ERWS	V_
21.16	2462	Vfcurrent lim I time	ms	FLOAT	CALCF	1.0	50.0	ERWS	V_
21.17	2470	Damping gain	perc	UINT16	0	0	100	ERW	V_
21.18	2472	Damping threshold 1	Hz	INT16	20	5	100	ERW	V_
21.19	2474	Damping threshold 2	Hz	INT16	30	5	100	ERW	V_
21.20	2480	Vf min frequency	Hz	FLOAT	1.0	0.2	5.0	ERW	V_
21.21	2482	Vf min freq delay	ms	UINT16	800	0	5000	ERW	V_
21.22	2490	Dig Vf scale		FLOAT	16/32 1.0	0.0	1.0	ERWZ	V_
21.23	2492	Vf scale src		LINK	16/32 3374	0	16384	ERW	V_
				L_VREF					

22 - FUNCTIONS

22.1 - FUNCTIONS/SPEED RATIO

22.1.1	3000	Dig speed ratio		INT16	16/32 100	CALCI	CALCI	ERW	VS
--------	------	-----------------	--	-------	-----------	-------	-------	-----	----

Menu	PAR	Description	UM	Type	FB BIT Def	Min	Max	Acc	Mod
22.1.2	3002	Speed ratio src		LINK	16/32 3000	0	16384	ERW	VS
				L_VREF					
22.1.3	3008	Speed ratio div		ENUM	Div 1	0	3	ERW	VS
				1	1				
				10	10				
				100	100				
				1000	1000				
22.1.4	3010	Speed ratio mon	perc	FLOAT	0	0	0	ER	VS

22.2 - FUNCTIONS/INERTIA COMP

22.2.1	3100	Inertia comp	kgm2	FLOAT	0.0	0.0	100.0	ERWS	S
22.2.2	3102	Inertia comp filter	ms	UINT16	30	1	100	ERW	S
22.2.3	3104	Inertia comp mon	perc	FLOAT	16/32 0.0	0.0	0.0	ER	S

22.3 - FUNCTIONS/DC BRAKING

22.3.1	3150	DC braking cmd src		LINK	16BIT 6000	0	16384	ERW	VS
				L_DIGSEL2					
22.3.2	3152	DC brake mode		ENUM	Off	0	3	ERW	VS
				0	Off				
				1	At Stop				
				2	On Command				
				3	OnCmd & AtStop				
22.3.3	3154	DC brake delay	s	FLOAT	0.5	0.00	30.0	ERW	VS
22.3.4	3156	DC brake duration	s	FLOAT	1.0	0.01	30.0	ERW	VS
22.3.5	3158	DC brake current	perc	FLOAT	50.0	0.0	150.0	ERW	VS
22.3.6	3160	DC brake state		ENUM	16BIT Not active	0	1	ER	VS
				0	Not active				
				1	Active				

22.4 - FUNCTIONS/MOTOR OVERLOAD

22.4.1	3200	Motor ovld enable		BIT	0	0	1	ERW	VS
22.4.2	3202	Motor ovld factor	perc	FLOAT	150.0	100.0	300.0	ERWS	VS
22.4.3	3204	Motor ovld time	s	FLOAT	30.0	10.0	300.0	ERWS	VS
22.4.4	3206	Motor service factor	perc	FLOAT	100.0	25.0	200.0	ERWS	VS
22.4.5	3216	Motor fan type		ENUM	Servo fan	0	1	ERW	VS
				0	Auto fan				
				1	Servo fan				
22.4.6	3218	Motor derat factor	perc	FLOAT	50.0	0.0	100.0	ERWS	VS

22.5 - FUNCTIONS/BRES OVERLOAD

22.5.1	3250	Bres control		BIT	0	0	1	ERWZ	VS
22.5.2	3252	Bres value	ohm	FLOAT	SIZE	7.0	1000.0	ERWS	VS
22.5.3	3254	Bres cont power	kW	FLOAT	SIZE	0.1	100.0	ERWS	VS
22.5.4	3256	Bres overload factor		FLOAT	SIZE	1.5	10.0	ERWS	VS
22.5.5	3258	Bres overload time	s	FLOAT	SIZE	0.5	50.0	ERWS	VS

22.6 - FUNCTIONS/SPEED CAPTURE

22.6.1	3350	Speed capture		ENUM	Disable	0	2	ERW	V_
				0	Disable				
				1	Alarm restart				
				2	Enable&restart				
22.6.2	3364	Vf catch start freq	Hz	FLOAT	CALCF	-500.0	500.0	ERWZ	V_
22.6.3	3366	Vf catch enable dly	ms	UINT16	1000	10	10000	ERWZ	V_

Menu	PAR	Description	UM	Type	FB BIT	Def	Min	Max	Acc	Mod
22.6.4	3368	Vf catch search time	s	FLOAT		2.0	1.0	30.0	ERW	V_
22.6.5	3370	Vf catch P gain	perc	FLOAT		10.0	0.0	100.0	ERW	V_
22.6.6	3372	Vf catch I time	ms	UINT16		200	200	1000	ERW	V_
22.6.7	3376	Vf catch lastref dly	ms	UINT16		0	0	30000	ERWZ	V_

22.7 - FUNCTIONS/POWER LOSS

22.7.1	3400	Powerloss function		ENUM		Disable	0	1	ERWZ	V_
				0		Disable				
				1		Enable				
22.7.2	3402	Powerloss accel time	s	FLOAT		10.0	0.01	100.0	ERW	V_
22.7.3	3404	Powerloss decel time	s	FLOAT		2.0	0.01	100.0	ERW	V_
22.7.4	3410	Powerloss Vdcref	V	FLOAT		CALCF	0.0	CALCF	ERWZS	V_
22.7.5	3420	Powerloss P gain	A/V	FLOAT		CALCF	0.0	100.000	ERWS	V_
22.7.6	3422	Powerloss I time	ms	FLOAT		CALCF	1.0	1000.0	ERWS	V_
22.7.7	3438	Powerloss mode		ENUM		Ramp down	0	1	ERWZ	V_
				0		Ramp down				
				1		Restart				
22.7.8	3440	Powerloss mains src		LINK		16BIT 6000	0	16384	ERWZ	V_
						L_DIGSEL2				

22.8 - FUNCTIONS/COMPARE

22.8.1	3650	Dig compare input 1	perc	FLOAT	32BIT	0.0	-100.0	100.0	ERW	VS
22.8.2	3652	Dig compare input 2	perc	FLOAT	32BIT	0.0	-100.0	100.0	ERW	VS
22.8.3	3660	Compare input 1 src		LINK	32BIT	3650	0	16384	ERW	VS
						L_CMP				
22.8.4	3662	Compare input 2 src		LINK	32BIT	3652	0	16384	ERW	VS
						L_CMP				
22.8.5	3670	Compare function		ENUM		None	0	8	ERW	VS
				0		None				
				1		Inp1=Inp2				
				2		Inp1!=Inp2				
				3		Inp1<Inp2				
				4		Inp1>Inp2				
				5		Inp1 = Inp2				
				6		Inp1 != Inp2				
				7		Inp1 < Inp2				
				8		Inp1 > Inp2				
22.8.6	3672	Compare window	perc	FLOAT		0.0	0.0	100.0	ERW	VS
22.8.7	3674	Compare delay	s	FLOAT		0.0	0.0	30.0	ERW	VS
22.8.8	3676	Compare output		BIT	16BIT	0	0	1	ER	VS

22.9 - FUNCTIONS/PADS

22.9.1	3700	Pad 1		INT32	32BIT	0	0	0	ERW	VS
22.9.2	3702	Pad 2		INT32	32BIT	0	0	0	ERW	VS
22.9.3	3704	Pad 3		INT32	32BIT	0	0	0	ERW	VS
22.9.4	3706	Pad 4		INT32	32BIT	0	0	0	ERW	VS
22.9.5	3708	Pad 5		INT32	32BIT	0	0	0	ERW	VS
22.9.6	3710	Pad 6		INT32	32BIT	0	0	0	ERW	VS
22.9.7	3712	Pad 7		INT32	32BIT	0	0	0	ERW	VS
22.9.8	3714	Pad 8		INT32	32BIT	0	0	0	ERW	VS
22.9.9	3716	Pad 9		INT32	32BIT	0	0	0	ERW	VS
22.9.10	3718	Pad 10		INT32	32BIT	0	0	0	ERW	VS
22.9.11	3720	Pad 11		INT32	32BIT	0	0	0	ERW	VS
22.9.12	3722	Pad 12		INT32	32BIT	0	0	0	ERW	VS

Menu	PAR	Description	UM	Type	FB BIT Def	Min	Max	Acc	Mod
22.9.13	3724	Pad 13		INT32	32BIT 0	0	0	ERW	VS
22.9.14	3726	Pad 14		INT32	32BIT 0	0	0	ERW	VS
22.9.15	3728	Pad 15		INT32	32BIT 0	0	0	ERW	VS
22.9.16	3730	Pad 16		INT32	32BIT 0	0	0	ERW	VS

22.10 - FUNCTIONS/VDC CONTROL

22.10.1	3450	Vdc control function		ENUM	Disable	0	1	ERWZ	VS
				0	Disable				
				1	Enable				
22.10.2	3470	Vdc control P gain	A/V	FLOAT	CALCF	0.0	100.000	ERWS	VS
22.10.3	3472	Vdc control I time	ms	FLOAT	CALCF	1.0	1000.0	ERWS	VS

22.11 - FUNCTIONS/BRAKE CONTROL

22.11.1	3170	Brake control funct		ENUM	Disable	0	1	ERWZ	VS
				0	Disable				
				1	Enable				
22.11.2	3172	Brake open delay	s	FLOAT	0.20	0.0	60.0	ERW	VS
22.11.3	3174	Brake close delay	s	FLOAT	0.20	0.0	60.0	ERW	VS

22.12 - FUNCTIONS/VF ENERGY SAVE

22.12.1	3320	Energysave enable		BIT	0	0	1	ERWZ	V_
22.12.2	3322	Energysave spd band	rpm	INT16	2	0	100	ERW	V_
22.12.3	3324	Energysave delay	s	FLOAT	3.0	0.1	120.0	ERW	V_
22.12.4	3326	Energysave trqband 1	perc	FLOAT	10.0	0.0	100.0	ERWS	V_
22.12.5	3328	Energysave trqband 2	perc	FLOAT	10.0	0.0	100.0	ERWS	V_
22.12.6	3340	Energysave out		FLOAT	16/32 0.0	0.0	1.0	ER	V_

22.13 - FUNCTIONS/RTC_SET

22.13.1	3980	Rtc year		UINT16	2000	2000	2069	ERW	VS
22.13.2	3982	Rtc month		UINT16	1	1	12	ERW	VS
22.13.3	3984	Rtc day		UINT16	1	1	31	ERW	VS
22.13.4	3986	Rtc hour		UINT16	0	0	23	ERW	VS
22.13.5	3988	Rtc minute		UINT16	0	0	59	ERW	VS
22.13.6	3990	Rtc second		UINT16	0	0	59	ERW	VS
22.13.7	3992	Rtc calibration		INT16	0	-31	31	ERW	VS

23 - COMMUNICATION

23.1 - COMMUNICATION/RS485

23.1.1	3800	Drive address		UINT16	1	1	255	ERW	VS
23.1.2	3802	Serial baudrate		ENUM	38400	0	2	ERW	VS
				0	9600				
				1	19200				
				2	38400				
23.1.3	3810	Serial parameter		ENUM	N_8_1	0	3	ERW	VS
				0	None,8,1				
				1	None,8,2				
				2	Even,8,1				
				3	Odd,8,1				
23.1.4	3804	Serial protocol		ENUM	Modbus	0	1	ERW	VS
				0	Modbus				
				1	Jbus				
23.1.5	3806	Serial delay	ms	UINT16	0	0	1000	ERW	VS

Menu	PAR	Description	UM	Type	FB BIT Def	Min	Max	Acc	Mod
23.1.6	3808	Serial swap data		BIT	0	0	1	ERW	VS

23.2 - COMMUNICATION/FIELDBUS CONFIG

23.2.1	4000	Fieldbus type		ENUM	Off	0	6	RW	VS
				0	Off				
				1	CanOpen				
				2	DeviceNet				
				3	Profibus				
				10	DS402				
				30	Profidrive				
				40	Rte				
23.2.2	4004	Fieldbus baudrate		ENUM	500k	0	12	RW	VS
				0	Auto				
				1	125k				
				2	250k				
				3	500k				
				4	1M				
				5	9600				
				6	19200				
				7	93750				
				8	187,5k				
				9	1,5M				
				10	3M				
				11	6M				
				12	12M				
23.2.3	4006	Fieldbus address		INT16	3	0	255	RW	VS
23.2.4	4010	Fieldbus M->S enable		ENUM	Enable	0	1	ERWZ	VS
				0	Disable				
				1	Enable				
23.2.5	4012	Fieldbus alarm mode		INT32	0	0	1	ERWZ	VS
23.2.6	4014	Fieldbus state		ENUM	Stop	0	9	R	VS
				0	Stop				
				1	PreOperational				
				2	Operational				
				3	Error				
				4	WaitPRM				
				5	WaitCFG				
				6	DataExchange				
				7	DPErrors				
				8	SafeOp				
				9	Init				
23.2.7	4398	RTE protocol		ENUM	None	0	107	ER	VS
				0	None				
				1	Ethercat				
				2	EthernetIP				
				3	GdNet				
				4	Profinet				
				5	ModbusTCP				
				6	Powerlink				
				107	Profidrive				
23.2.8	5608	IP address		UINT32	0	0	4294967295	ER	VS

23.3 - COMMUNICATION/FIELDBUS M->S

23.3.1	4020	Fieldbus M->S1 ipa		FBM2SIPA	0	0	20000	RW	VS
23.3.2	4022	Fieldbus M->S1 sys		ENUM	Not assigned	0	10	RW	VS
				0	Not assigned				
				1	Count 16				
				2	Count 32				

Menu	PAR	Description	UM	Type	FB BIT Def	Min	Max	Acc	Mod
				3	Fill 16				
				4	Fill 32				
				5	Mdplc 16				
				6	Mdplc 32				
				7	Eu				
				8	Eu float				
				9	Par 16				
				10	Par 32				
23.3.3	4024	Fieldbus M->S1 mon		INT32	32BIT 0	0	0	ER	VS
23.3.4	4026	Fieldbus M->S1 div		FLOAT	1.0	1.0	1000.0	ERW	VS
23.3.5	4030	Fieldbus M->S2 ipa		FBM2SIPA	0	0	20000	RW	VS
23.3.6	4032	Fieldbus M->S2 sys		ENUM	Not assigned 0		10	RW	VS
				0	Not assigned				
				1	Count 16				
				2	Count 32				
				3	Fill 16				
				4	Fill 32				
				5	Mdplc 16				
				6	Mdplc 32				
				7	Eu				
				8	Eu float				
				9	Par 16				
				10	Par 32				
23.3.7	4034	Fieldbus M->S2 mon		INT32	32BIT 0	0	0	ER	VS
23.3.8	4036	Fieldbus M->S2 div		FLOAT	1.0	1.0	1000.0	ERW	VS
23.3.9	4040	Fieldbus M->S3 ipa		FBM2SIPA	0	0	20000	RW	VS
23.3.10	4042	Fieldbus M->S3 sys		ENUM	Not assigned 0		10	RW	VS
				0	Not assigned				
				1	Count 16				
				2	Count 32				
				3	Fill 16				
				4	Fill 32				
				5	Mdplc 16				
				6	Mdplc 32				
				7	Eu				
				8	Eu float				
				9	Par 16				
				10	Par 32				
23.3.11	4044	Fieldbus M->S3 mon		INT32	32BIT 0	0	0	ER	VS
23.3.12	4046	Fieldbus M->S3 div		FLOAT	1.0	1.0	1000.0	ERW	VS
23.3.13	4050	Fieldbus M->S4 ipa		FBM2SIPA	0	0	20000	RW	VS
23.3.14	4052	Fieldbus M->S4 sys		ENUM	Not assigned 0		10	RW	VS
				0	Not assigned				
				1	Count 16				
				2	Count 32				
				3	Fill 16				
				4	Fill 32				
				5	Mdplc 16				
				6	Mdplc 32				
				7	Eu				
				8	Eu float				
				9	Par 16				
				10	Par 32				
23.3.15	4054	Fieldbus M->S4 mon		INT32	32BIT 0	0	0	ER	VS
23.3.16	4056	Fieldbus M->S4 div		FLOAT	1.0	1.0	1000.0	ERW	VS
23.3.17	4060	Fieldbus M->S5 ipa		FBM2SIPA	0	0	20000	RW	VS
23.3.18	4062	Fieldbus M->S5 sys		ENUM	Not assigned 0		10	RW	VS
				0	Not assigned				

Menu	PAR	Description	UM	Type	FB BIT Def	Min	Max	Acc	Mod
				1	Count 16				
				2	Count 32				
				3	Fill 16				
				4	Fill 32				
				5	Mdplc 16				
				6	Mdplc 32				
				7	Eu				
				8	Eu float				
				9	Par 16				
				10	Par 32				
23.3.19	4064	Fieldbus M->S5 mon		INT32	32BIT 0	0	0	ER	VS
23.3.20	4066	Fieldbus M->S5 div		FLOAT	1.0	1.0	1000.0	ERW	VS
23.3.21	4070	Fieldbus M->S6 ipa		FBM2SIPA	0	0	20000	RW	VS
23.3.22	4072	Fieldbus M->S6 sys		ENUM	Not assigned 0		10	RW	VS
				0	Not assigned				
				1	Count 16				
				2	Count 32				
				3	Fill 16				
				4	Fill 32				
				5	Mdplc 16				
				6	Mdplc 32				
				7	Eu				
				8	Eu float				
				9	Par 16				
				10	Par 32				
23.3.23	4074	Fieldbus M->S6 mon		INT32	32BIT 0	0	0	ER	VS
23.3.24	4076	Fieldbus M->S6 div		FLOAT	1.0	1.0	1000.0	ERW	VS
23.3.25	4080	Fieldbus M->S7 ipa		FBM2SIPA	0	0	20000	RW	VS
23.3.26	4082	Fieldbus M->S7 sys		ENUM	Not assigned 0		10	RW	VS
				0	Not assigned				
				1	Count 16				
				2	Count 32				
				3	Fill 16				
				4	Fill 32				
				5	Mdplc 16				
				6	Mdplc 32				
				7	Eu				
				8	Eu float				
				9	Par 16				
				10	Par 32				
23.3.27	4084	Fieldbus M->S7 mon		INT32	32BIT 0	0	0	ER	VS
23.3.28	4086	Fieldbus M->S7 div		FLOAT	1.0	1.0	1000.0	ERW	VS
23.3.29	4090	Fieldbus M->S8 ipa		FBM2SIPA	0	0	20000	RW	VS
23.3.30	4092	Fieldbus M->S8 sys		ENUM	Not assigned 0		10	RW	VS
				0	Not assigned				
				1	Count 16				
				2	Count 32				
				3	Fill 16				
				4	Fill 32				
				5	Mdplc 16				
				6	Mdplc 32				
				7	Eu				
				8	Eu float				
				9	Par 16				
				10	Par 32				
23.3.31	4094	Fieldbus M->S8 mon		INT32	32BIT 0	0	0	ER	VS
23.3.32	4096	Fieldbus M->S8 div		FLOAT	1.0	1.0	1000.0	ERW	VS
23.3.33	4100	Fieldbus M->S9 ipa		FBM2SIPA	0	0	20000	RW	VS

Menu	PAR	Description	UM	Type	FB BIT Def	Min	Max	Acc	Mod
23.3.34	4102	Fieldbus M->S9 sys		ENUM	Not assigned	0	10	RW	VS
				0	Not assigned				
				1	Count 16				
				2	Count 32				
				3	Fill 16				
				4	Fill 32				
				5	Mdplc 16				
				6	Mdplc 32				
				7	Eu				
				8	Eu float				
				9	Par 16				
				10	Par 32				
23.3.35	4104	Fieldbus M->S9 mon		INT32	32BIT 0	0	0	ER	VS
23.3.36	4106	Fieldbus M->S9 div		FLOAT	1.0	1.0	1000.0	ERW	VS
23.3.37	4110	Fieldbus M->S10 ipa		FBM2SIPA	0	0	20000	RW	VS
23.3.38	4112	Fieldbus M->S10 sys		ENUM	Not assigned	0	10	RW	VS
				0	Not assigned				
				1	Count 16				
				2	Count 32				
				3	Fill 16				
				4	Fill 32				
				5	Mdplc 16				
				6	Mdplc 32				
				7	Eu				
				8	Eu float				
				9	Par 16				
				10	Par 32				
23.3.39	4114	Fieldbus M->S10 mon		INT32	32BIT 0	0	0	ER	VS
23.3.40	4116	Fieldbus M->S10 div		FLOAT	1.0	1.0	1000.0	ERW	VS
23.3.41	4120	Fieldbus M->S11 ipa		FBM2SIPA	0	0	20000	RW	VS
23.3.42	4122	Fieldbus M->S11 sys		ENUM	Not assigned	0	10	RW	VS
				0	Not assigned				
				1	Count 16				
				2	Count 32				
				3	Fill 16				
				4	Fill 32				
				5	Mdplc 16				
				6	Mdplc 32				
				7	Eu				
				8	Eu float				
				9	Par 16				
				10	Par 32				
23.3.43	4124	Fieldbus M->S11 mon		INT32	32BIT 0	0	0	ER	VS
23.3.44	4126	Fieldbus M->S11 div		FLOAT	1.0	1.0	1000.0	ERW	VS
23.3.45	4130	Fieldbus M->S12 ipa		FBM2SIPA	0	0	20000	RW	VS
23.3.46	4132	Fieldbus M->S12 sys		ENUM	Not assigned	0	10	RW	VS
				0	Not assigned				
				1	Count 16				
				2	Count 32				
				3	Fill 16				
				4	Fill 32				
				5	Mdplc 16				
				6	Mdplc 32				
				7	Eu				
				8	Eu float				
				9	Par 16				
				10	Par 32				
23.3.47	4134	Fieldbus M->S12 mon		INT32	32BIT 0	0	0	ER	VS
23.3.48	4136	Fieldbus M->S12 div		FLOAT	1.0	1.0	1000.0	ERW	VS

Menu	PAR	Description	UM	Type	FB BIT Def	Min	Max	Acc	Mod
23.3.49	4140	Fieldbus M->S13 ipa		FBM2SIPA	0	0	20000	RW	VS
23.3.50	4142	Fieldbus M->S13 sys		ENUM	Not assigned	0	10	RW	VS
				0	Not assigned				
				1	Count 16				
				2	Count 32				
				3	Fill 16				
				4	Fill 32				
				5	Mdplc 16				
				6	Mdplc 32				
				7	Eu				
				8	Eu float				
				9	Par 16				
				10	Par 32				
23.3.51	4144	Fieldbus M->S13 mon		INT32	32BIT 0	0	0	ER	VS
23.3.52	4146	Fieldbus M->S13 div		FLOAT	1.0	1.0	1000.0	ERW	VS
23.3.53	4150	Fieldbus M->S14 ipa		FBM2SIPA	0	0	20000	RW	VS
23.3.54	4152	Fieldbus M->S14 sys		ENUM	Not assigned	0	10	RW	VS
				0	Not assigned				
				1	Count 16				
				2	Count 32				
				3	Fill 16				
				4	Fill 32				
				5	Mdplc 16				
				6	Mdplc 32				
				7	Eu				
				8	Eu float				
				9	Par 16				
				10	Par 32				
23.3.55	4154	Fieldbus M->S14 mon		INT32	32BIT 0	0	0	ER	VS
23.3.56	4156	Fieldbus M->S14 div		FLOAT	1.0	1.0	1000.0	ERW	VS
23.3.57	4160	Fieldbus M->S15 ipa		FBM2SIPA	0	0	20000	RW	VS
23.3.58	4162	Fieldbus M->S15 sys		ENUM	Not assigned	0	10	RW	VS
				0	Not assigned				
				1	Count 16				
				2	Count 32				
				3	Fill 16				
				4	Fill 32				
				5	Mdplc 16				
				6	Mdplc 32				
				7	Eu				
				8	Eu float				
				9	Par 16				
				10	Par 32				
23.3.59	4164	Fieldbus M->S15 mon		INT32	32BIT 0	0	0	ER	VS
23.3.60	4166	Fieldbus M->S15 div		FLOAT	1.0	1.0	1000.0	ERW	VS
23.3.61	4170	Fieldbus M->S16 ipa		FBM2SIPA	0	0	20000	RW	VS
23.3.62	4172	Fieldbus M->S16 sys		ENUM	Not assigned	0	10	RW	VS
				0	Not assigned				
				1	Count 16				
				2	Count 32				
				3	Fill 16				
				4	Fill 32				
				5	Mdplc 16				
				6	Mdplc 32				
				7	Eu				
				8	Eu float				
				9	Par 16				
				10	Par 32				
23.3.63	4174	Fieldbus M->S16 mon		INT32	32BIT 0	0	0	ER	VS

Menu	PAR	Description	UM	Type	FB BIT Def	Min	Max	Acc	Mod
23.3.64	4176	Fieldbus M->S16 div		FLOAT	1.0	1.0	1000.0	ERW	VS

23.4 - COMMUNICATION/FIELDBUS S->M

23.4.1	4180	Fieldbus S->M1 ipa		FBS2MIPA	0	0	20000	RW	VS
23.4.2	4182	Fieldbus S->M1 sys		ENUM	Not assigned	0	10	RW	VS
				0	Not assigned				
				1	Count 16				
				2	Count 32				
				3	Fill 16				
				4	Fill 32				
				5	Mdplc 16				
				6	Mdplc 32				
				7	Eu				
				8	Eu float				
				9	Par 16				
				10	Par 32				
23.4.3	4184	Dig Fieldbus S->M1		INT32	32BIT 0	0	0	ERW	VS
23.4.4	4186	Fieldbus S->M1 mul		FLOAT	1.0	1.0	1000.0	ERW	VS
23.4.5	4190	Fieldbus S->M2 ipa		FBS2MIPA	0	0	20000	RW	VS
23.4.6	4192	Fieldbus S->M2 sys		ENUM	Not assigned	0	10	RW	VS
				0	Not assigned				
				1	Count 16				
				2	Count 32				
				3	Fill 16				
				4	Fill 32				
				5	Mdplc 16				
				6	Mdplc 32				
				7	Eu				
				8	Eu float				
				9	Par 16				
				10	Par 32				
23.4.7	4194	Dig Fieldbus S->M2		INT32	32BIT 0	0	0	ERW	VS
23.4.8	4196	Fieldbus S->M2 mul		FLOAT	1.0	1.0	1000.0	ERW	VS
23.4.9	4200	Fieldbus S->M3 ipa		FBS2MIPA	0	0	20000	RW	VS
23.4.10	4202	Fieldbus S->M3 sys		ENUM	Not assigned	0	10	RW	VS
				0	Not assigned				
				1	Count 16				
				2	Count 32				
				3	Fill 16				
				4	Fill 32				
				5	Mdplc 16				
				6	Mdplc 32				
				7	Eu				
				8	Eu float				
				9	Par 16				
				10	Par 32				
23.4.11	4204	Dig Fieldbus S->M3		INT32	32BIT 0	0	0	ERW	VS
23.4.12	4206	Fieldbus S->M3 mul		FLOAT	1.0	1.0	1000.0	ERW	VS
23.4.13	4210	Fieldbus S->M4 ipa		FBS2MIPA	0	0	20000	RW	VS
23.4.14	4212	Fieldbus S->M4 sys		ENUM	Not assigned	0	10	RW	VS
				0	Not assigned				
				1	Count 16				
				2	Count 32				
				3	Fill 16				
				4	Fill 32				
				5	Mdplc 16				
				6	Mdplc 32				
				7	Eu				

Menu	PAR	Description	UM	Type	FB BIT Def	Min	Max	Acc	Mod
				8	Eu float				
				9	Par 16				
				10	Par 32				
23.4.15	4214	Dig Fieldbus S->M4		INT32	32BIT 0	0	0	ERW	VS
23.4.16	4216	Fieldbus S->M4 mul		FLOAT	1.0	1.0	1000.0	ERW	VS
23.4.17	4220	Fieldbus S->M5 ipa		FBS2MIPA	0	0	20000	RW	VS
23.4.18	4222	Fieldbus S->M5 sys		ENUM	Not assigned 0		10	RW	VS
				0	Not assigned				
				1	Count 16				
				2	Count 32				
				3	Fill 16				
				4	Fill 32				
				5	Mdplc 16				
				6	Mdplc 32				
				7	Eu				
				8	Eu float				
				9	Par 16				
				10	Par 32				
23.4.19	4224	Dig Fieldbus S->M5		INT32	32BIT 0	0	0	ERW	VS
23.4.20	4226	Fieldbus S->M5 mul		FLOAT	1.0	1.0	1000.0	ERW	VS
23.4.21	4230	Fieldbus S->M6 ipa		FBS2MIPA	0	0	20000	RW	VS
23.4.22	4232	Fieldbus S->M6 sys		ENUM	Not assigned 0		10	RW	VS
				0	Not assigned				
				1	Count 16				
				2	Count 32				
				3	Fill 16				
				4	Fill 32				
				5	Mdplc 16				
				6	Mdplc 32				
				7	Eu				
				8	Eu float				
				9	Par 16				
				10	Par 32				
23.4.23	4234	Dig Fieldbus S->M6		INT32	32BIT 0	0	0	ERW	VS
23.4.24	4236	Fieldbus S->M6 mul		FLOAT	1.0	1.0	1000.0	ERW	VS
23.4.25	4240	Fieldbus S->M7 ipa		FBS2MIPA	0	0	20000	RW	VS
23.4.26	4242	Fieldbus S->M7 sys		ENUM	Not assigned 0		10	RW	VS
				0	Not assigned				
				1	Count 16				
				2	Count 32				
				3	Fill 16				
				4	Fill 32				
				5	Mdplc 16				
				6	Mdplc 32				
				7	Eu				
				8	Eu float				
				9	Par 16				
				10	Par 32				
23.4.27	4244	Dig Fieldbus S->M7		INT32	32BIT 0	0	0	ERW	VS
23.4.28	4246	Fieldbus S->M7 mul		FLOAT	1.0	1.0	1000.0	ERW	VS
23.4.29	4250	Fieldbus S->M8 ipa		FBS2MIPA	0	0	20000	RW	VS
23.4.30	4252	Fieldbus S->M8 sys		ENUM	Not assigned 0		10	RW	VS
				0	Not assigned				
				1	Count 16				
				2	Count 32				
				3	Fill 16				
				4	Fill 32				
				5	Mdplc 16				

Menu	PAR	Description	UM	Type	FB BIT Def	Min	Max	Acc	Mod
				6	Mdplc 32				
				7	Eu				
				8	Eu float				
				9	Par 16				
				10	Par 32				
23.4.31	4254	Dig Fieldbus S->M8		INT32	32BIT 0	0	0	ERW	VS
23.4.32	4256	Fieldbus S->M8 mul		FLOAT	1.0	1.0	1000.0	ERW	VS
23.4.33	4260	Fieldbus S->M9 ipa		FBS2MIPA	0	0	20000	RW	VS
23.4.34	4262	Fieldbus S->M9 sys		ENUM	Not assigned 0		10	RW	VS
				0	Not assigned				
				1	Count 16				
				2	Count 32				
				3	Fill 16				
				4	Fill 32				
				5	Mdplc 16				
				6	Mdplc 32				
				7	Eu				
				8	Eu float				
				9	Par 16				
				10	Par 32				
23.4.35	4264	Dig Fieldbus S->M9		INT32	32BIT 0	0	0	ERW	VS
23.4.36	4266	Fieldbus S->M9 mul		FLOAT	1.0	1.0	1000.0	ERW	VS
23.4.37	4270	Fieldbus S->M10 ipa		FBS2MIPA	0	0	20000	RW	VS
23.4.38	4272	Fieldbus S->M10 sys		ENUM	Not assigned 0		10	RW	VS
				0	Not assigned				
				1	Count 16				
				2	Count 32				
				3	Fill 16				
				4	Fill 32				
				5	Mdplc 16				
				6	Mdplc 32				
				7	Eu				
				8	Eu float				
				9	Par 16				
				10	Par 32				
23.4.39	4274	Dig Fieldbus S->M10		INT32	32BIT 0	0	0	ERW	VS
23.4.40	4276	Fieldbus S->M10 mul		FLOAT	1.0	1.0	1000.0	ERW	VS
23.4.41	4280	Fieldbus S->M11 ipa		FBS2MIPA	0	0	20000	RW	VS
23.4.42	4282	Fieldbus S->M11 sys		ENUM	Not assigned 0		10	RW	VS
				0	Not assigned				
				1	Count 16				
				2	Count 32				
				3	Fill 16				
				4	Fill 32				
				5	Mdplc 16				
				6	Mdplc 32				
				7	Eu				
				8	Eu float				
				9	Par 16				
				10	Par 32				
23.4.43	4284	Dig Fieldbus S->M11		INT32	32BIT 0	0	0	ERW	VS
23.4.44	4286	Fieldbus S->M11 mul		FLOAT	1.0	1.0	1000.0	ERW	VS
23.4.45	4290	Fieldbus S->M12 ipa		FBS2MIPA	0	0	20000	RW	VS
23.4.46	4292	Fieldbus S->M12 sys		ENUM	Not assigned 0		10	RW	VS
				0	Not assigned				
				1	Count 16				
				2	Count 32				
				3	Fill 16				

Menu	PAR	Description	UM	Type	FB BIT Def	Min	Max	Acc	Mod
				4	Fill 32				
				5	Mdplc 16				
				6	Mdplc 32				
				7	Eu				
				8	Eu float				
				9	Par 16				
				10	Par 32				
23.4.47	4294	Dig Fieldbus S->M12		INT32	32BIT 0	0	0	ERW	VS
23.4.48	4296	Fieldbus S->M12 mul		FLOAT	1.0	1.0	1000.0	ERW	VS
23.4.49	4300	Fieldbus S->M13 ipa		FBS2MIPA	0	0	20000	RW	VS
23.4.50	4302	Fieldbus S->M13 sys		ENUM	Not assigned 0		10	RW	VS
				0	Not assigned				
				1	Count 16				
				2	Count 32				
				3	Fill 16				
				4	Fill 32				
				5	Mdplc 16				
				6	Mdplc 32				
				7	Eu				
				8	Eu float				
				9	Par 16				
				10	Par 32				
23.4.51	4304	Dig Fieldbus S->M13		INT32	32BIT 0	0	0	ERW	VS
23.4.52	4306	Fieldbus S->M13 mul		FLOAT	1.0	1.0	1000.0	ERW	VS
23.4.53	4310	Fieldbus S->M14 ipa		FBS2MIPA	0	0	20000	RW	VS
23.4.54	4312	Fieldbus S->M14 sys		ENUM	Not assigned 0		10	RW	VS
				0	Not assigned				
				1	Count 16				
				2	Count 32				
				3	Fill 16				
				4	Fill 32				
				5	Mdplc 16				
				6	Mdplc 32				
				7	Eu				
				8	Eu float				
				9	Par 16				
				10	Par 32				
23.4.55	4314	Dig Fieldbus S->M14		INT32	32BIT 0	0	0	ERW	VS
23.4.56	4316	Fieldbus S->M14 mul		FLOAT	1.0	1.0	1000.0	ERW	VS
23.4.57	4320	Fieldbus S->M15 ipa		FBS2MIPA	0	0	20000	RW	VS
23.4.58	4322	Fieldbus S->M15 sys		ENUM	Not assigned 0		10	RW	VS
				0	Not assigned				
				1	Count 16				
				2	Count 32				
				3	Fill 16				
				4	Fill 32				
				5	Mdplc 16				
				6	Mdplc 32				
				7	Eu				
				8	Eu float				
				9	Par 16				
				10	Par 32				
23.4.59	4324	Dig Fieldbus S->M15		INT32	32BIT 0	0	0	ERW	VS
23.4.60	4326	Fieldbus S->M15 mul		FLOAT	1.0	1.0	1000.0	ERW	VS
23.4.61	4330	Fieldbus S->M16 ipa		FBS2MIPA	0	0	20000	RW	VS
23.4.62	4332	Fieldbus S->M16 sys		ENUM	Not assigned 0		10	RW	VS
				0	Not assigned				
				1	Count 16				

Menu	PAR	Description	UM	Type	FB BIT Def	Min	Max	Acc	Mod
				2	Count 32				
				3	Fill 16				
				4	Fill 32				
				5	Mdplc 16				
				6	Mdplc 32				
				7	Eu				
				8	Eu float				
				9	Par 16				
				10	Par 32				
23.4.63	4334	Dig Fieldbus S->M16		INT32	32BIT 0	0	0	ERW	VS
23.4.64	4336	Fieldbus S->M16 mul		FLOAT	1.0	1.0	1000.0	ERW	VS

23.5 - COMMUNICATION/WORD COMP

23.5.1	4400	Word bit0 src		LINK	16BIT 6000	0	16384	ERW	VS
				L_DIGSEL1					
23.5.2	4402	Word bit1 src		LINK	16BIT 6000	0	16384	ERW	VS
				L_DIGSEL1					
23.5.3	4404	Word bit2 src		LINK	16BIT 6000	0	16384	ERW	VS
				L_DIGSEL1					
23.5.4	4406	Word bit3 src		LINK	16BIT 6000	0	16384	ERW	VS
				L_DIGSEL1					
23.5.5	4408	Word bit4 src		LINK	16BIT 6000	0	16384	ERW	VS
				L_DIGSEL1					
23.5.6	4410	Word bit5 src		LINK	16BIT 6000	0	16384	ERW	VS
				L_DIGSEL1					
23.5.7	4412	Word bit6 src		LINK	16BIT 6000	0	16384	ERW	VS
				L_DIGSEL1					
23.5.8	4414	Word bit7 src		LINK	16BIT 6000	0	16384	ERW	VS
				L_DIGSEL1					
23.5.9	4416	Word bit8 src		LINK	16BIT 6000	0	16384	ERW	VS
				L_DIGSEL1					
23.5.10	4418	Word bit9 src		LINK	16BIT 6000	0	16384	ERW	VS
				L_DIGSEL1					
23.5.11	4420	Word bit10 src		LINK	16BIT 6000	0	16384	ERW	VS
				L_DIGSEL1					
23.5.12	4422	Word bit11 src		LINK	16BIT 6000	0	16384	ERW	VS
				L_DIGSEL1					
23.5.13	4424	Word bit12 src		LINK	16BIT 6000	0	16384	ERW	VS
				L_DIGSEL1					
23.5.14	4426	Word bit13 src		LINK	16BIT 6000	0	16384	ERW	VS
				L_DIGSEL1					
23.5.15	4428	Word bit14 src		LINK	16BIT 6000	0	16384	ERW	VS
				L_DIGSEL1					
23.5.16	4430	Word bit15 src		LINK	16BIT 6000	0	16384	ERW	VS
				L_DIGSEL1					
23.5.17	4432	Word comp mon		UINT32	16BIT 0	0	0	ER	VS

23.6 - COMMUNICATION/WORD DECOMP

23.6.1	4450	Dig word decomp		UINT32	16BIT 0	0	0	ERW	VS
23.6.2	4452	Word decomp src		LINK	16BIT 4450	0	16384	ERW	VS
				L_WDECOMP					
23.6.3	4454	Bit0 decomp mon		BIT	16BIT 0	0	1	ER	VS
23.6.4	4456	Bit1 decomp mon		BIT	16BIT 0	0	1	ER	VS
23.6.5	4458	Bit2 decomp mon		BIT	16BIT 0	0	1	ER	VS
23.6.6	4460	Bit3 decomp mon		BIT	16BIT 0	0	1	ER	VS

Menu	PAR	Description	UM	Type	FB BIT Def	Min	Max	Acc	Mod
23.6.7	4462	Bit4 decomp mon		BIT	16BIT 0	0	1	ER	VS
23.6.8	4464	Bit5 decomp mon		BIT	16BIT 0	0	1	ER	VS
23.6.9	4466	Bit6 decomp mon		BIT	16BIT 0	0	1	ER	VS
23.6.10	4468	Bit7 decomp mon		BIT	16BIT 0	0	1	ER	VS
23.6.11	4470	Bit8 decomp mon		BIT	16BIT 0	0	1	ER	VS
23.6.12	4472	Bit9 decomp mon		BIT	16BIT 0	0	1	ER	VS
23.6.13	4474	Bit10 decomp mon		BIT	16BIT 0	0	1	ER	VS
23.6.14	4476	Bit11 decomp mon		BIT	16BIT 0	0	1	ER	VS
23.6.15	4478	Bit12 decomp mon		BIT	16BIT 0	0	1	ER	VS
23.6.16	4480	Bit13 decomp mon		BIT	16BIT 0	0	1	ER	VS
23.6.17	4482	Bit14 decomp mon		BIT	16BIT 0	0	1	ER	VS
23.6.18	4484	Bit15 decomp mon		BIT	16BIT 0	0	1	ER	VS

24 - ALARM CONFIG

24.1	4500	Fault reset src		LINK	16BIT 1120	0	16384	RW	VS
				L_DIGSEL2					
24.2	4502	ExtFlt src		LINK	16BIT 6000	0	16384	RW	VS
				L_DIGSEL2					
24.3	4504	ExtFlt activity		ENUM	Disable	0	4	RW	VS
				0	Ignore				
				1	Warning				
				2	Disable				
				3	Stop				
				4	Fast stop				
24.4	4506	ExtFlt restart		ENUM	Disable	0	1	RW	VS
				0	Disable				
				1	Enable				
24.5	4508	ExtFlt restart time	ms	UINT16	1000	120	30000	RW	VS
24.6	4510	ExtFlt holdoff	ms	UINT16	0	0	10000	RW	VS
24.7	4520	MotorOT src		LINK	16BIT 6000	0	16384	RW	VS
				L_DIGSEL2					
24.8	4522	MotorOT activity		ENUM	Warning	0	4	RW	VS
				0	Ignore				
				1	Warning				
				2	Disable				
				3	Stop				
				4	Fast stop				
24.9	4524	MotorOT restart		ENUM	Disable	0	1	RW	VS
				0	Disable				
				1	Enable				
24.10	4526	MotorOT restart time	ms	UINT16	1000	120	30000	RW	VS
24.11	4528	MotorOT holdoff	ms	UINT16	1000	0	30000	RW	VS
24.12	4530	MotorOT probe		ENUM	SRC	0	4	RW	VS
				0	SRC				
				1	PT100 AN1X				
				2	PT100 AN2X				
				3	KTY84				
				4	PTC				
24.13	4532	MotorOT thr	cnt	UINT16	0	0	32767	RW	VS
24.14	4536	MotorOT mon	cnt	INT16	0	0	32767	R	VS
24.15	4540	Overspeed threshold	rpm	INT32	CALCI	0	CALCI	RW	VS
24.16	4542	Overspeed activity		ENUM	Disable	0	4	RW	VS
				0	Ignore				
				1	Warning				
				2	Disable				
				3	Stop				

Menu	PAR	Description	UM	Type	FB BIT Def	Min	Max	Acc	Mod
				4	Fast stop				
24.17	4544	Overspeed holdoff	ms	UINT16	0	0	5000	RW	VS
24.18	4550	SpdRefLoss threshold	rpm	INT16	100	0	CALCI	RW	VS
24.19	4552	SpdRefLoss activity		ENUM	Ignore	0	4	RW	VS
				0	Ignore				
				1	Warning				
				2	Disable				
				3	Stop				
				4	Fast stop				
24.20	4554	SpdRefLoss holdoff	ms	UINT16	1000	0	10000	RW	VS
24.21	4570	Drive ovld activity		ENUM	Ignore	0	4	ERW	VS
				0	Ignore				
				1	Warning				
				2	Disable				
				3	Stop				
				4	Fast stop				
24.22	4572	Motor ovld activity		ENUM	Warning	0	4	ERW	VS
				0	Ignore				
				1	Warning				
				2	Disable				
				3	Stop				
				4	Fast stop				
24.23	4574	Bres ovld activity		ENUM	Disable	0	4	ERW	VS
				0	Ignore				
				1	Warning				
				2	Disable				
				3	Stop				
				4	Fast stop				
24.24	4582	HTsens restart		ENUM	Disable	0	1	ERW	VS
				0	Disable				
				1	Enable				
24.25	4584	HTsens restart time	ms	UINT16	20000	120	60000	ERW	VS
24.26	4600	InAir activity		ENUM	Stop	0	4	ERW	VS
				0	Ignore				
				1	Warning				
				2	Disable				
				3	Stop				
				4	Fast stop				
24.27	4602	InAir restart		ENUM	Disable	0	1	ERW	VS
				0	Disable				
				1	Enable				
24.28	4604	InAir restart time	ms	UINT16	1000	120	30000	ERW	VS
24.29	4606	InAir holdoff	ms	UINT16	10000	0	30000	ERW	VS
24.30	4610	Desat restart		ENUM	Disable	0	1	ERW	VS
				0	Disable				
				1	Enable				
24.31	4612	Desat restart time	ms	UINT16	2000	1000	10000	ERW	VS
24.32	4620	IOverC restart		ENUM	Disable	0	1	ERW	VS
				0	Disable				
				1	Enable				
24.33	4622	IOverC restart time	ms	UINT16	2000	1000	10000	ERW	VS
24.34	4630	OverV restart		ENUM	Disable	0	1	ERW	VS
				0	Disable				
				1	Enable				
24.35	4632	OverV restart time	ms	UINT16	2000	1000	10000	ERW	VS
24.36	4640	UnderV restart		ENUM	Enable	0	1	ERW	VS
				0	Disable				
				1	Enable				

Menu	PAR	Description	UM	Type	FB BIT Def	Min	Max	Acc	Mod
24.37	4642	UnderV restart time	ms	UINT16	1000	120	10000	ERW	VS
24.38	4650	UVRep attempts		UINT16	5	0	1000	ERW	VS
24.39	4652	UVRep delay	s	UINT16	240	0	300	ERW	VS
24.40	4660	PhLoss activity		ENUM	Disable	0	4	ERW	VS
				0	Ignore				
				1	Warning				
				2	Disable				
				3	Stop				
				4	Fast stop				
24.41	4662	PhLoss restart		ENUM	Disable	0	1	ERW	VS
				0	Disable				
				1	Enable				
24.42	4664	PhLoss restart time	ms	UINT16	1000	120	10000	ERW	VS
24.43	4670	Optionbus activity		ENUM	Disable	0	4	ERW	VS
				0	Ignore				
				1	Warning				
				2	Disable				
				3	Stop				
				4	Fast stop				
24.44	4672	Optbus fault en src		LINK	16BIT 6002	0	16384	ERW	VS
24.45	4680	GroundFault thr	perc	FLOAT	10.0	0.0	150.0	ERWS	VS
24.46	4700	Alarm dig sel 1		ENUM	No alarm	0	40	ERW	VS
				0	No alarm				
				1	Overvoltage				
				2	Undervoltage				
				3	Ground fault				
				4	Overcurrent				
				5	Desaturation				
				6	MultiUndervolt				
				7	MultiOvercurr				
				8	MultiDesat				
				9	Heatsink OT				
				10	HeatsinkS OTUT				
				11	Intakeair OT				
				12	Motor OT				
				13	Drive overload				
				14	Motor overload				
				15	Bres overload				
				16	Phaseloss				
				17	Opt Bus fault				
				18	Opt 1 IO fault				
				19	Opt 2 IO fault				
				20	Not Used1				
				21	External fault				
				22	Not Used2				
				23	Overspeed				
				24	Speed ref loss				
				25	Emg stop alarm				
				26	Power down				
				27	Broken belt				
				28	End curve				
				29	Dry pump				
				30	No flow				
				31	Clean alarm				
				32	Not Used6				
				33	Min Speed				
				34	Plc2 fault				
				35	Plc3 fault				
				36	Plc4 fault				
				37	Plc5 fault				

Menu	PAR	Description	UM	Type	FB BIT Def	Min	Max	Acc	Mod
					38				
					39				
					40				
24.47	4702	Alarm dig sel 2		ENUM	No alarm	0	40	ERW	VS
					0				
					1				
					2				
					3				
					4				
					5				
					6				
					7				
					8				
					9				
					10				
					11				
					12				
					13				
					14				
					15				
					16				
					17				
					18				
					19				
					20				
					21				
					22				
					23				
					24				
					25				
					26				
					27				
					28				
					29				
					30				
					31				
					32				
					33				
					34				
					35				
					36				
					37				
					38				
					39				
					40				
24.48	4704	Alarm dig sel 3		ENUM	No alarm	0	40	ERW	VS
					0				
					1				
					2				
					3				
					4				
					5				
					6				
					7				
					8				
					9				
					10				
					11				
					12				
					13				
					14				

Menu	PAR	Description	UM	Type	FB BIT Def	Min	Max	Acc	Mod
				15	Bres overload				
				16	Phaseloss				
				17	Opt Bus fault				
				18	Opt 1 IO fault				
				19	Opt 2 IO fault				
				20	Not Used1				
				21	External fault				
				22	Not Used2				
				23	Overspeed				
				24	Speed ref loss				
				25	Emg stop alarm				
				26	Power down				
				27	Broken belt				
				28	End curve				
				29	Dry pump				
				30	No flow				
				31	Clean alarm				
				32	Not Used6				
				33	Min Speed				
				34	Plc2 fault				
				35	Plc3 fault				
				36	Plc4 fault				
				37	Plc5 fault				
				38	Plc6 fault				
				39	Plc7 fault				
				40	Plc8 fault				
24.49	4706	Alarm dig sel 4		ENUM	No alarm	0	40	ERW	VS
				0	No alarm				
				1	Overvoltage				
				2	Undervoltage				
				3	Ground fault				
				4	Overcurrent				
				5	Desaturation				
				6	MultiUndervolt				
				7	MultiOvercurr				
				8	MultiDesat				
				9	Heatsink OT				
				10	HeatsinkS OTUT				
				11	Intakeair OT				
				12	Motor OT				
				13	Drive overload				
				14	Motor overload				
				15	Bres overload				
				16	Phaseloss				
				17	Opt Bus fault				
				18	Opt 1 IO fault				
				19	Opt 2 IO fault				
				20	Not Used1				
				21	External fault				
				22	Not Used2				
				23	Overspeed				
				24	Speed ref loss				
				25	Emg stop alarm				
				26	Power down				
				27	Broken belt				
				28	End curve				
				29	Dry pump				
				30	No flow				
				31	Clean alarm				
				32	Not Used6				
				33	Min Speed				

Menu	PAR	Description	UM	Type	FB BIT Def	Min	Max	Acc	Mod
				34	Plc2 fault				
				35	Plc3 fault				
				36	Plc4 fault				
				37	Plc5 fault				
				38	Plc6 fault				
				39	Plc7 fault				
				40	Plc8 fault				
24.50	4720	Alm autoreset time	s	FLOAT	0.0	0.0	60.0	ERW	VS
24.51	4722	Alm autoreset number		UINT16	20	0	100	ERW	VS
24.52	7700	Broken belt activity		ENUM	Warning	0	4	RW	VS
				0	Ignore				
				1	Warning				
				2	Disable				
				3	Stop				
				4	Fast stop				
24.53	7702	Broken belt torque	perc	FLOAT	0.0	0.0	100.0	RW	VS
24.54	7704	Broken belt delay	s	UINT16	30	1	3600	RW	VS
24.55	7706	Broken belt spd thr	rpm	INT16	100	0	CALCI	RW	VS
24.56	7710	End curve activity		ENUM	Warning	0	4	RW	VS
				0	Ignore				
				1	Warning				
				2	Disable				
				3	Stop				
				4	Fast stop				
24.57	7712	End curve ref thr	perc	INT16	0	0	100	RW	VS
24.58	7714	End curve delay	s	UINT16	30	1	3600	RW	VS
24.59	7720	Dry pump activity		ENUM	Warning	0	4	RW	VS
				0	Ignore				
				1	Warning				
				2	Disable				
				3	Stop				
				4	Fast stop				
24.60	7722	Dry pump delay	s	UINT16	30	1	3600	RW	VS
24.61	7726	No flow activity		ENUM	Warning	0	4	RW	VS
				0	Ignore				
				1	Warning				
				2	Disable				
				3	Stop				
				4	Fast stop				
24.62	7728	No flow delay	s	UINT16	30	1	3600	RW	VS
24.63	7808	Clean alm num cycles		UINT16	1	1	100	RW	VS
24.64	7810	Clean alm thr time	h	UINT16	0	0	8760	RW	VS
24.65	7812	Clean activity		ENUM	Warning	0	4	RW	VS
				0	Ignore				
				1	Warning				
				2	Disable				
				3	Stop				
				4	Fast stop				
24.66	7816	Analog 1 err act		ENUM	Ignore	0	4	RW	VS
				0	Ignore				
				1	Warning				
				2	Disable				
				3	Stop				
				4	Fast stop				
24.67	7818	Analog 1 err delay	s	FLOAT	1	0.1	60	RW	VS
24.68	7820	Analog 2 err act		ENUM	Ignore	0	4	RW	VS
				0	Ignore				
				1	Warning				

Menu	PAR	Description	UM	Type	FB BIT Def	Min	Max	Acc	Mod
				2	Disable				
				3	Stop				
				4	Fast stop				
24.69	7822	Analog 2 err delay	s	FLOAT	1	0.1	60	RW	VS
24.70	7824	Analog 1x err act		ENUM	Ignore	0	4	RW	VS
				0	Ignore				
				1	Warning				
				2	Disable				
				3	Stop				
				4	Fast stop				
24.71	7826	Analog 1x err delay	s	FLOAT	1	0.1	60	RW	VS
24.72	7828	Analog 2x err act		ENUM	Ignore	0	4	RW	VS
				0	Ignore				
				1	Warning				
				2	Disable				
				3	Stop				
				4	Fast stop				
24.73	7830	Analog 2x err delay	s	FLOAT	1	0.1	60	RW	VS

25 - ALARM LOG

26 - PROCESS

26.1 - PROCESS/PID 1 REFERENCES

26.1.1	7300	PID 1 dig ref 1	PID1U	FLOAT	0.0	CALCF	CALCF	RW	VS
26.1.2	7302	PID 1 ref 1 src		LINK	16/32 7300	0	16384	RW	VS
				L_PIDREF					
26.1.3	7304	PID 1 dig ref 2	PID1U	FLOAT	0.0	CALCF	CALCF	RW	VS
26.1.4	7306	PID 1 ref 2 src		LINK	16/32 7304	0	16384	RW	VS
				L_PIDREF					
26.1.5	7308	PID 1 ref function		ENUM	Ref1	0	5	RW	VS
				0	Ref1				
				1	Ref2				
				2	Src selection				
				3	Ref1+ref2				
				4	Ref1-ref2				
				5	Aver ref1 ref2				
26.1.6	7310	PID 1 reference max	PID1U	FLOAT	100.0	0.0	999999.0	RW	VS
26.1.7	7312	PID 1 ref sel src		LINK	16BIT 6000	0	16384	RW	VS
				L_DIGSEL2					
26.1.8	7314	PID 1 ref filter	s	FLOAT	0.0	0.0	10.0	RW	VS
26.1.9	7316	PID 1 ref out mon	PID1U	FLOAT	0.0	0.0	0.0	R	VS
26.1.10	7320	PID 1 fbk 1 src		LINK	16/32 6000	0	16384	RW	VS
				L_PIDFBK					
26.1.11	7322	PID 1 fbk 2 src		LINK	16/32 6000	0	16384	RW	VS
				L_PIDFBK					
26.1.12	7324	PID 1 fbk function		ENUM	Fbk1	0	10	RW	VS
				0	Fbk1				
				1	Fbk2				
				2	Fbk1+fbk2				
				3	Fbk1-fbk2				
				4	Fbk1*fbk2				
				5	Fbk1/fbk2				
				6	Min fbk1fbk2				
				7	Max fbk1 fbk2				
				8	Aver fbk1 fbk2				
				9	2 Zone min				

Menu	PAR	Description	UM	Type	FB BIT Def	Min	Max	Acc	Mod
				10	2 Zone max				
26.1.13	7336	PID 1 fbk filter	s	FLOAT	0.0	0.0	10.0	RW	VS
26.1.14	7326	PID 1 fbk out mon	PID1U	FLOAT	0.0	0.0	0.0	R	VS
26.1.15	7330	PID 1 process unit		ENUM	perc	0	39	RW	VS
				0					
				1	%				
				2	rpm				
				3	ppm				
				4	imp/s				
				5	l/s				
				6	l/m				
				7	l/h				
				8	kg/s				
				9	kg/m				
				10	kg/h				
				11	m3/s				
				12	m3/m				
				13	m3/h				
				14	m/s				
				15	mbar				
				16	bar				
				17	Pa				
				18	kPa				
				19	m				
				20	m ca				
				21	kW				
				22	°C				
				23	°F				
				24	GPM				
				25	gal/s				
				26	gal/m				
				27	gal/h				
				28	lb/s				
				29	lb/m				
				30	lb/h				
				31	CFM				
				32	ft3/s				
				33	ft3/m				
				34	ft3/h				
				35	ft/s				
				36	in wg				
				37	ft wg				
				38	PSI				
				39	lb/i2				

26.2 - PROCESS/PID 1

26.2.1	7600	PID 1 enable		ENUM	Disable	0	1	RWZ	VS
				0	Disable				
				1	Enable				
26.2.2	7602	PID 1 error inver		ENUM	Disable	0	1	RWZ	VS
				0	Disable				
				1	Enable				
26.2.3	7604	PID 1 antiwindup		ENUM	Disable	0	1	RWZ	VS
				0	Disable				
				1	Enable				
26.2.4	7606	PID 1 P gain		FLOAT	10.0	0.0	100.0	RW	VS
26.2.5	7608	PID 1 I time	s	FLOAT	60.0	0.0	3600.0	RW	VS
26.2.6	7610	PID 1 D time	s	FLOAT	0.0	0.0	1.0	RW	VS
26.2.7	7614	PID 1 filter	s	FLOAT	0.0	0.0	10.0	RW	VS

Menu	PAR	Description	UM	Type	FB BIT Def	Min	Max	Acc	Mod
26.2.8	7618	PID 1 limit pos	perc	FLOAT	100.0	0.0	200.0	RW	VS
26.2.9	7620	PID 1 limit neg	perc	FLOAT	0.0	-200	0.0	RW	VS
26.2.10	7622	PID 1 I limit	perc	FLOAT	100.0	0.0	200.0	RW	VS
26.2.11	7624	PID 1 fbk scale		FLOAT	1.0	-10.0	10.0	RW	VS
26.2.12	7626	PID 1 out	perc	INT16	16/32 0	0	0	R	VS
26.2.13	7628	PID 1 fbk tune min	PID1U	FLOAT	0.0	0.0	0.0	ERW	VS
26.2.14	7630	PID 1 fbk tune max	PID1U	FLOAT	100.0	0.0	0.0	ERW	VS
26.2.15	7632	PID 1 fbk tune thr 1	perc	FLOAT	0.10	0.00	10	ERW	VS
26.2.16	7634	PID 1 fbk tune thr 2	perc	FLOAT	20.00	1.00	100.00	ERW	VS
26.2.17	7636	PID 1 ref autotune	perc	INT16	0	0	100	ERW	VS
26.2.18	7638	PID 1 autotune		BIT	0	0	1	ERWZ	VS
26.2.19	7640	PID 1 tune timeout	s	UINT16	60	10	600	ERW	VS

26.3 - PROCESS/PID 2 REFERENCES

26.3.1	7350	PID 2 dig ref 1	PID2U	FLOAT	0	CALCF	CALCF	RW	VS
26.3.2	7352	PID 2 ref 1 src		LINK	16/32 7350	0	16384	RW	VS
				L_PIDREF					
26.3.3	7354	PID 2 dig ref 2	PID2U	FLOAT	0.0	CALCF	CALCF	RW	VS
26.3.4	7356	PID 2 ref 2 src		LINK	16/32 7354	0	16384	RW	VS
				L_PIDREF					
26.3.5	7358	PID 2 ref function		ENUM	Ref1	0	5	RW	VS
				0	Ref1				
				1	Ref2				
				2	Src selection				
				3	Ref1 + ref2				
				4	Ref1-ref2				
				5	Aver ref1 ref2				
26.3.6	7360	PID 2 reference max	PID2U	FLOAT	100.0	0.0	999999.0	RW	VS
26.3.7	7362	PID 2 ref sel src		LINK	16BIT 6000	0	16384	RW	VS
				L_DIGSEL2					
26.3.8	7364	PID 2 ref filter	s	FLOAT	0.0	0.0	10.0	RW	VS
26.3.9	7366	PID 2 ref out mon	PID2U	FLOAT	0.0	0.0	0.0	R	VS
26.3.10	7370	PID 2 fbk 1 src		LINK	16/32 6000	0	16384	RW	VS
				L_PIDFBK					
26.3.11	7372	PID 2 fbk 2 src		LINK	16/32 6000	0	16384	RW	VS
				L_PIDFBK					
26.3.12	7374	PID 2 fbk function		ENUM	Fbk1	0	10	RW	VS
				0	Fbk1				
				1	Fbk2				
				2	Fbk1 + fbk2				
				3	Fbk1-fbk2				
				4	Fbk1*fbk2				
				5	Fbk1/fbk2				
				6	Min fbk1fbk2				
				7	Max fbk1 fbk2				
				8	Aver fbk1 fbk2				
				9	2 Zone min				
				10	2 Zone max				
26.3.13	7386	PID 2 fbk filter	s	FLOAT	0.0	0.0	10.0	RW	VS
26.3.14	7376	PID 2 fbk out mon	PID2U	FLOAT	0.0	0.0	0.0	R	VS
26.3.15	7380	PID 2 process unit		ENUM	perc	0	39	RW	VS
				0					
				1	%				
				2	rpm				
				3	ppm				
				4	imp/s				

Menu	PAR	Description	UM	Type	FB BIT Def	Min	Max	Acc	Mod
				5	l/s				
				6	l/m				
				7	l/h				
				8	kg/s				
				9	kg/m				
				10	kg/h				
				11	m3/s				
				12	m3/m				
				13	m3/h				
				14	m/s				
				15	mbar				
				16	bar				
				17	Pa				
				18	kPa				
				19	m				
				20	m ca				
				21	kW				
				22	°C				
				23	°F				
				24	GPM				
				25	gal/s				
				26	gal/m				
				27	gal/h				
				28	lb/s				
				29	lb/m				
				30	lb/h				
				31	CFM				
				32	ft3/s				
				33	ft3/m				
				34	ft3/h				
				35	ft/s				
				36	in wg				
				37	ft wg				
				38	PSI				
				39	lb/i2				

26.4 - PROCESS/PID 2

26.4.1	7650	PID 2 enable		ENUM	Disable	0	1	RWZ	VS
				0	Disable				
				1	Enable				
26.4.2	7652	PID 2 error inver		ENUM	Disable	0	1	RWZ	VS
				0	Disable				
				1	Enable				
26.4.3	7654	PID 2 antiwindup		ENUM	Disable	0	1	RWZ	VS
				0	Disable				
				1	Enable				
26.4.4	7656	PID 2 P gain		FLOAT	10.0	0.0	100.0	RW	VS
26.4.5	7658	PID 2 I time	s	FLOAT	60.0	0.0	3600.0	RW	VS
26.4.6	7660	PID 2 D time	s	FLOAT	0.0	0.0	1.0	RW	VS
26.4.7	7664	PID 2 filter	s	FLOAT	0.0	0.0	10.0	RW	VS
26.4.8	7668	PID 2 limit pos	perc	FLOAT	100.0	0.0	200.0	RW	VS
26.4.9	7670	PID 2 limit neg	perc	FLOAT	0.0	-200	0.0	RW	VS
26.4.10	7672	PID 2 I limit	perc	FLOAT	100.0	0.0	200.0	RW	VS
26.4.11	7674	PID 2 fbk scale		FLOAT	1.0	-10.0	10.0	RW	VS
26.4.12	7676	PID 2 out	perc	INT16	16/32	0	0	R	VS
26.4.13	7678	PID 2 fbk tune min	PID2U	FLOAT	0.0	0.0	0.0	ERW	VS
26.4.14	7680	PID 2 fbk tune max	PID2U	FLOAT	100.0	0.0	0.0	ERW	VS
26.4.15	7682	PID 2 fbk tune thr 1	perc	FLOAT	0.10	0.00	10	ERW	VS

Menu	PAR	Description	UM	Type	FB BIT Def	Min	Max	Acc	Mod
26.4.16	7684	PID 2 fbk tune thr 2	perc	FLOAT	20.00	1.00	100.00	ERW	VS
26.4.17	7686	PID 2 ref autotune	perc	INT16	1	1	100	ERW	VS
26.4.18	7688	PID 2 autotune		BIT	0	0	1	ERWZ	VS
26.4.19	7690	PID 2 tune timeout	s	UINT16	60	10	600	ERW	VS

26.5 - PROCESS/SLEEP MODE

26.5.1	7440	Sleep mode		ENUM	Disable	0	1	RW	VS
				0	Disable				
				1	Enable				
26.5.2	7442	Sleep speed thr	rpm	INT16	500	0	CALCI	RW	VS
26.5.3	7444	Sleep delay	s	INT16	10	0	600	RW	VS
26.5.4	7446	Const pressure thr	perc	INT16	0	0	100	RW	VS
26.5.5	7448	Const press thr time	s	INT16	10	0	600	RW	VS
26.5.6	7450	Wakeup threshold	perc	INT16	10	0	100	RW	VS
26.5.7	7452	Wakeup delay	s	INT16	10	0	600	RW	VS
26.5.8	7454	Fluid loss thr	perc	INT16	10	0	50	RW	VS
26.5.9	7456	Fluid loss time	s	INT16	10	0	600	RW	VS
26.5.10	7458	Boost value	perc	FLOAT	0.0	0.0	100.0	RW	VS
26.5.11	7460	Boost duration	s	INT16	15	0	600	RW	VS
26.5.12	7462	Sleep active mon		BIT	16BIT 0	0	1	R	VS

26.6 - PROCESS/FLOW COMPENS

26.6.1	7500	FC enable		ENUM	Disable	0	1	RW	VS
				0	Disable				
				1	Enable				
26.6.2	7502	FC speed 0	rpm	INT16	10	0	CALCI	RW	VS
26.6.3	7504	FC head 0	PID1U	FLOAT	10.0	0.0	1000.0	RW	VS
26.6.4	7506	FC design speed	rpm	INT16	1000	0	CALCI	RW	VS
26.6.5	7508	FC head setpoint	PID1U	FLOAT	100.0	0.0	1000.0	RW	VS
26.6.6	7510	FC curve correction	perc	UINT16	100	0	100	RW	VS
26.6.7	7512	FC step 1 ref		FLOAT	10.0	0.0	1000.0	RW	VS
26.6.8	7514	FC step 2 ref		FLOAT	10.0	0.0	1000.0	RW	VS
26.6.9	7516	FC step 3 ref		FLOAT	10.0	0.0	1000.0	RW	VS
26.6.10	7518	FC step 4 ref		FLOAT	10.0	0.0	1000.0	RW	VS
26.6.11	7520	FC ref out mon		FLOAT	0	0	1000.0	R	VS

26.7 - PROCESS/FILL

26.7.1	7470	Fill enable		ENUM	Disable	0	1	RW	VS
				0	Disable				
				1	Enable				
26.7.2	7472	Fill speed	rpm	INT16	0	0	CALCI	RW	VS
26.7.3	7474	Fill speed time	s	INT16	0.0	0.0	3600.0	RW	VS
26.7.4	7476	Fill setpoint	PID1U	FLOAT	0.0	CALCF	CALCF	RW	VS
26.7.5	7478	Fill time	s	INT16	0.0	0.0	3600	RW	VS
26.7.6	7492	Fill enable src		LINK	16BIT 7470	0	16384	ERW	VS

26.8 - PROCESS/MIN FREQUENCY

26.8.1	7480	Freq min	rpm	INT16	0	0	CALCI	RW	VS
26.8.2	7482	Freq min time	s	UINT16	10	1	3600	RW	VS

26.9 - PROCESS/CHECK VALVE

26.9.1	7484	Check valve enable		ENUM	Disable	0	1	RW	VS
--------	------	--------------------	--	------	---------	---	---	----	----

Menu	PAR	Description	UM	Type	FB BIT Def	Min	Max	Acc	Mod
					0				
					1				
26.9.2	7486	Check valve spd low	rpm	INT16	0	0	CALCI	RW	VS
26.9.3	7488	Check valve spd hi	rpm	INT16	0	0	CALCI	RW	VS
26.9.4	7490	Check valve time	s	UINT16	30	1	3600	RW	VS

26.10 - PROCESS/PUMP CLEAN

26.10.1	7780	Clean mode		ENUM	Disable	0	2	RW	VS
				0	Disable				
				1	On start				
				2	Normal				
26.10.2	7782	Clean dig start src		LINK	16BIT 6000	0	16384	RW	VS
					L_DIGSEL2				
26.10.3	7784	Clean an start src		LINK	16BIT 6000	0	16384	RW	VS
					L_ANOUT				
26.10.4	7786	Clean an start thr	perc	INT16	0	0	100	RW	VS
26.10.5	7788	Clean an start time	s	UINT16	10	0	500	RW	VS
26.10.6	7790	Clean num cycles		UINT16	1	1	100	RW	VS
26.10.7	7792	Clean fwd speed	rpm	INT16	50	0	CALCI	RW	VS
26.10.8	7794	Clean rev speed	rpm	INT16	50	0	CALCI	RW	VS
26.10.9	7796	Clean fwd time	s	UINT16	10	0	1000	RW	VS
26.10.10	7798	Clean rev time	s	UINT16	10	0	1000	RW	VS
26.10.11	7800	Clean acc time	s	UINT16	5	1	1000	RW	VS
26.10.12	7802	Clean dec time	s	UINT16	5	1	1000	RW	VS
26.10.13	7804	Clean stop time	s	UINT16	5	0	1000	RW	VS
26.10.14	7806	Clean period time	h	UINT16	0	0	30000	RW	VS
26.10.15	7778	Clean period mon	h	UINT16	0	0	0	R	VS
26.10.16	7814	Clean active mon		ENUM	Not active	0	4	R	VS
				0	Not active				
				1	On start				
				2	Digital src				
				3	Analog src				
				4	Period src				

26.11 - PROCESS/LOW POWER CALC

26.11.1	7740	Low power calc		ENUM	Disable	0	1	RW	VS
				0	Disable				
				1	Enable				
26.11.2	7742	Low power speed	rpm	INT16	0	0	CALCI	RW	VS
26.11.3	7744	Low power	kW	FLOAT	0.0	0.0	CALCF	RW	VS
26.11.4	7746	Hi power speed	rpm	INT16	0	0	CALCI	RW	VS
26.11.5	7748	Hi power	kW	FLOAT	0.0	0.0	CALCF	RW	VS
26.11.6	7750	Low pow correc fact	perc	FLOAT	100.0	0.0	200.0	RW	VS
26.11.7	7752	Low power mon	kW	FLOAT	0.0	0.0	0.0	R	VS

26.12 - PROCESS/FIRE FUNCTION

26.12.1	7840	Fire function		ENUM	Disable	0	3	RW	VS
				0	Disable				
				1	Forward				
				2	Reverse				
				3	Forward bypass				
26.12.2	7842	Fire command src		LINK	16BIT 6000	0	16384	RW	VS
					L_DIGSEL2				
26.12.3	7844	Fire speed	rpm	INT16	0	0	CALCI	RW	VS

Menu	PAR	Description	UM	Type	FB BIT Def	Min	Max	Acc	Mod
26.12.4	7846	Fire bypass delay	s	INT16	0.0	0.0	3600	RW	VS
26.12.5	7848	Fire bypass mon		BIT	16BIT 0	0	1	R	VS
26.12.6	7850	Fire out mon		BIT	16BIT 0	0	1	R	VS

26.13 - PROCESS/TIMERS

26.13.1	7860	TI 1 week day start		ENUM	Sunday	0	6	RW	VS
				0	Sunday				
				1	Monday				
				2	Tuesday				
				3	Wednesday				
				4	Thursday				
				5	Friday				
				6	Saturday				
26.13.2	7862	TI 1 hour start	h	UINT16	0	0	23	RW	VS
26.13.3	7864	TI 1 minute start	min	UINT16	0	0	59	RW	VS
26.13.4	7866	TI 1 week day stop		ENUM	Sunday	0	6	RW	VS
				0	Sunday				
				1	Monday				
				2	Tuesday				
				3	Wednesday				
				4	Thursday				
				5	Friday				
				6	Saturday				
26.13.5	7868	TI 1 hour stop	h	UINT16	0	0	24	RW	VS
26.13.6	7870	TI 1 minute stop	min	UINT16	0	0	59	RW	VS
26.13.7	7872	TI 2 week day start		ENUM	Sunday	0	6	RW	VS
				0	Sunday				
				1	Monday				
				2	Tuesday				
				3	Wednesday				
				4	Thursday				
				5	Friday				
				6	Saturday				
26.13.8	7874	TI 2 hour start	h	UINT16	0	0	23	RW	VS
26.13.9	7876	TI 2 minute start	min	UINT16	0	0	59	RW	VS
26.13.10	7878	TI 2 week day stop		ENUM	Sunday	0	6	RW	VS
				0	Sunday				
				1	Monday				
				2	Tuesday				
				3	Wednesday				
				4	Thursday				
				5	Friday				
				6	Saturday				
26.13.11	7880	TI 2 hour stop	h	UINT16	0	0	24	RW	VS
26.13.12	7882	TI 2 minute stop	min	UINT16	0	0	59	RW	VS
26.13.13	7884	TI 3 week day start		ENUM	Sunday	0	6	RW	VS
				0	Sunday				
				1	Monday				
				2	Tuesday				
				3	Wednesday				
				4	Thursday				
				5	Friday				
				6	Saturday				
26.13.14	7886	TI 3 hour start	h	UINT16	0	0	23	RW	VS
26.13.15	7888	TI 3 minute start	min	UINT16	0	0	59	RW	VS
26.13.16	7890	TI 3 week day stop		ENUM	Sunday	0	6	RW	VS
				0	Sunday				

Menu	PAR	Description	UM	Type	FB BIT Def	Min	Max	Acc	Mod
				1	Monday				
				2	Tuesday				
				3	Wednesday				
				4	Thursday				
				5	Friday				
				6	Saturday				
26.13.17	7892	TI 3 hour stop	h	UINT16	0	0	24	RW	VS
26.13.18	7894	TI 3 minute stop	min	UINT16	0	0	59	RW	VS
26.13.19	7896	TI 4 week day start		ENUM	Sunday	0	6	RW	VS
				0	Sunday				
				1	Monday				
				2	Tuesday				
				3	Wednesday				
				4	Thursday				
				5	Friday				
				6	Saturday				
26.13.20	7898	TI 4 hour start	h	UINT16	0	0	23	RW	VS
26.13.21	7900	TI 4 minute start	min	UINT16	0	0	59	RW	VS
26.13.22	7902	TI 4 week day stop		ENUM	Sunday	0	6	RW	VS
				0	Sunday				
				1	Monday				
				2	Tuesday				
				3	Wednesday				
				4	Thursday				
				5	Friday				
				6	Saturday				
26.13.23	7904	TI 4 hour stop	h	UINT16	0	0	24	RW	VS
26.13.24	7906	TI 4 minute stop	min	UINT16	0	0	59	RW	VS
26.13.25	7908	Timer1 selection		UINT16	0	0	2222	RW	VS
26.13.26	7910	Timer1 active status		BIT	1	0	1	RW	VS
26.13.27	7912	Timer1 status mon		BIT	1	0	1	R	VS
26.13.28	7914	Timer2 selection		UINT16	0	0	2222	RW	VS
26.13.29	7916	Timer2 active status		BIT	1	0	1	RW	VS
26.13.30	7918	Timer2 status mon		BIT	1	0	1	R	VS
26.13.31	7920	Timer3 selection		UINT16	0	0	2222	RW	VS
26.13.32	7922	Timer3 active status		BIT	1	0	1	RW	VS
26.13.33	7924	Timer3 status mon		BIT	1	0	1	R	VS
26.13.34	7926	Timer4 selection		UINT16	0	0	2222	RW	VS
26.13.35	7928	Timer4 active status		BIT	1	0	1	RW	VS
26.13.36	7930	Timer4 status mon		BIT	1	0	1	R	VS

26.14 - PROCESS/MULTI PUMP

26.14.1	7100	Multi pump mode		ENUM	Disable	0	1	RWZ	VS
				0	Disable				
				1	Enable				
26.14.2	7102	Staging bandwidth	perc	INT16	10	0	100	RW	VS
26.14.3	7104	Staging delay	s	UINT16	30	1	3600	RW	VS
26.14.4	7106	Destaging delay	s	UINT16	30	1	3600	RW	VS
26.14.5	7108	Override bandwidth	perc	INT16	10	0	100	RW	VS
26.14.6	7110	Override time	s	UINT16	30	1	3600	RW	VS
26.14.7	7112	Staging speed	perc	INT16	30	0	100	RW	VS
26.14.8	7114	Destaging speed	perc	INT16	70	0	100	RW	VS
26.14.9	7116	Destage time	s	UINT16	0	0	3600	RW	VS
26.14.10	7118	Pumps cycle		BIT	0	0	1	RWZ	VS
26.14.11	7120	Alternation mode		ENUM	Disable	0	1	RWZ	VS

Menu	PAR	Description	UM	Type	FB BIT Def	Min	Max	Acc	Mod
				0	Disable				
				1	Enable				
26.14.12	7122	Alternation time	h	UINT16	0	0	999	RW	VS
26.14.13	7124	Alt actual time	h.min	UINT32	1	0	9999999	R	VS
26.14.14	7126	Altern ext event src		LINK	16BIT 6000	0	16384	RW	VS
				L_DIGSEL4					
26.14.15	7128	Altern restart delay	s	UINT16	30	1	3600	RW	VS
26.14.16	7130	Pump 1 intlock src		LINK	16BIT 6000	0	16384	RW	VS
				L_DIGSEL4					
26.14.17	7132	Pump 2 intlock src		LINK	16BIT 6000	0	16384	RW	VS
				L_DIGSEL4					
26.14.18	7134	Pump 3 intlock src		LINK	16BIT 6000	0	16384	RW	VS
				L_DIGSEL4					
26.14.19	7136	Pump 4 intlock src		LINK	16BIT 6000	0	16384	RW	VS
				L_DIGSEL4					
26.14.20	7138	Pump 5 intlock src		LINK	16BIT 6000	0	16384	RW	VS
				L_DIGSEL4					
26.14.21	7140	Pump 5 intlock src		LINK	16BIT 6000	0	16384	RW	VS
				L_DIGSEL4					
26.14.22	7142	Pump 7intlock src		LINK	16BIT 6000	0	16384	RW	VS
				L_DIGSEL4					
26.14.23	7144	Pump 8 intlock src		LINK	16BIT 6000	0	16384	RW	VS
				L_DIGSEL4					
26.14.24	7150	Pump 1 out mon		BIT	1	0	1	R	VS
26.14.25	7152	Pump 2 out mon		BIT	1	0	1	R	VS
26.14.26	7154	Pump 3 out mon		BIT	1	0	1	R	VS
26.14.27	7156	Pump 4 out mon		BIT	1	0	1	R	VS
26.14.28	7158	Pump 5 out mon		BIT	1	0	1	R	VS
26.14.29	7160	Pump 6 out mon		BIT	1	0	1	R	VS
26.14.30	7162	Pump 7 out mon		BIT	1	0	1	R	VS
26.14.31	7164	Pump 8 out mon		BIT	1	0	1	R	VS
26.14.32	7170	Pump 1 lead mon		BIT	1	0	1	R	VS
26.14.33	7172	Pump 2 lead mon		BIT	1	0	1	R	VS
26.14.34	7174	Pump 3 lead mon		BIT	1	0	1	R	VS
26.14.35	7176	Pump 4 lead mon		BIT	1	0	1	R	VS
26.14.36	7178	Pump 5 lead mon		BIT	1	0	1	R	VS
26.14.37	7180	Pump 6 lead mon		BIT	1	0	1	R	VS
26.14.38	7182	Pump 7 lead mon		BIT	1	0	1	R	VS
26.14.39	7184	Pump 8 lead mon		BIT	1	0	1	R	VS

27 - SOLAR PUMP

27.1 – CONFIGURATION

27.1.1	11000	App Enable	-	BIT	Off	-	-	RW	VS
27.1.2	11002	Max Pump Speed	rpm	FLOAT	1500	0	10000	RW	VS
27.1.3	11004	Min Pump Speed	rpm	FLOAT	0	0	10000	RW	VS
27.1.4	11006	Auto Setup	-	BIT	Off	-	-	RW	VS
27.1.5	11008	Control Mode	-	ENUM	0	-	-	RW	VS
				0	SOLAR SOURCE				
				1	AUTO DUAL SRC				
				2	AC SOURCE				
				3	AUTO HYBRID				
27.1.6	11010	Quick Setup	*	ENUM	* Off	*	*	RW	VS
				0	Off				

Menu	PAR	Description	UM	Type	FB BIT Def	Min	Max	Acc	Mod
				1	Standard				
				2	Fast				

27.2 – ALARM

27.2.1	11350	Min speed AI Act	*	ENUM	* Ignore	*	*	RW	VS
27.2.2	11352	Min speed AI TimeOut	s	DINT	* 30	1	1000	RW	VS

27.3 – I/O

27.3.1	11030	Irrad Sens Src	-	ENUM	1550	-	-	RW	VS
				6000	NULL				
				1	DIGITAL				
				1500	ANALOG INP 1				
				1550	ANALOG INP 2				
27.3.2	11032	Dig Irrad Sens	W/m ²	INT16	0	0	5000	RW	VS
27.3.3	11034	Irrad Sens Scale	-	FLOAT	1000.0	0.001	5000.0	RW	VS
27.3.4	11038	AC Relay Dest	-	ENUM	PAD15	-	-	RW	VS
				3716	Pad 9				
				3718	Pad 10				
				3720	Pad 11				
				3722	Pad 12				
				3724	Pad 13				
				3726	Pad 14				
				3728	Pad 15				
				3730	Pad 16				
				6000	Null				
27.3.5	11042	DC Relay Dest	-	ENUM	PAD16	-	-	RW	VS
27.3.6	11044	En MS Cntr Mode	-	ENUM	-	-	-	RW	VS
				0	Cmd Based				
				1	Dig Inp Based				
				2	Disabled				
27.3.7	11046	Src for MAN-AUTO mode	-	ENUM	-	-	-	RW	VS
				1112	Dig Inp 1				
				1114	Dig Inp 2				
				1116	Dig Inp 3				
				1118	Dig Inp 4				
				1120	Dig Inp 5				
				1210	Dig Inp 1X				
				1212	Dig Inp 2X				
				1214	Dig Inp 3X				
				1216	Dig Inp 4X				
				1218	Dig Inp 5X				
				1220	Dig Inp 6X				
				1222	Dig Inp 7X				
				1224	Dig Inp 8X				
				4454	Bit0 dec mon				
				4456	Bit1 dec mon				
				4458	Bit2 dec mon				
				4460	Bit3 dec mon				
				4462	Bit4 dec mon				
				4464	Bit5 dec mon				
				4466	Bit6 dec mon				
				4468	Bit7 dec mon				
				4470	Bit8 dec mon				
				4472	Bit9 dec mon				
				4474	Bit10 dec mon				
				4476	Bit11 dec mon				
				4478	Bit12 dec mon				

Menu	PAR	Description	UM	Type	FB BIT Def	Min	Max	Acc	Mod
				4480	Bit13 dec mon				
				4482	Bit14 dec mon				
				4484	Bit15 dec mon				
				6000	Null				
				6002	One				
27.3.8	11048	Src for TYPE of CNT	-	ENUM	-	-	-	RW	VS
27.3.9	12054	Irrad Sens Mon	W/m ²	FLOAT	-	-	-	RVS	VS

27.4 – SOURCE MANAGER

27.4.1	11050	AC-DC Switch mode	-	ENUM	-	-	-	RW	VS
				0	STOP SWITCH				
				1	RUN SWITCH				
27.4.2	11052	Switch speed	Rpm	INT16	1000	0	10000	RW	VS
27.4.3	11060	Irrad HIGH Thr	W/m ²	FLOAT	400	0	10000	RW	VS
27.4.4	11062	Vdc HIGH Thr	V	FLOAT	550	0	800	RW	VS
27.4.5	11066	Cond Trans DC-Mode	-	LOGIC	OR	-	-	RW	VS
				1	OR				
				2	AND				
27.4.6	11070	Irrad LOW Thr	W/m ²	FLOAT	400	0	10000	RW	VS
27.4.7	11072	Vdc LOW Thr	V	FLOAT	400.0	300.0	800.0	RW	VS
27.4.8	11074	Speed Thr	RPM	FLOAT	1000.0	0.0	10000.0	RW	VS
27.4.9	11076	Irrad Trans Condd	-	-	AND	-	-	RW	VS
				1	OR				
				2	AND (after)				
				3	AND (before)				
27.4.10	11078	Vdc Trans Cond	-	-	AND	-	-	RW	VS
				1	OR				
				2	AND (after)				
				3	AND (before)				
27.4.11	11080	Spd Trans Cond	-	-	AND	-	-	RW	VS
				1	OR				
				2	AND (after)				
				3	AND (before)				
27.4.12	11082	State Sw Hold Off	s	INT16	20	-	-	RW	VS
27.4.13	11084	Switch Delay	s	INT16	5	-	-	ERW	VS
27.4.14	12056	AC Relay Cmd Mon	-	BIT	-	-	-	R	VS
27.4.15	12058	DC Relay Cmd Mon	-	BIT	-	-	-	R	VS
27.4.16	12060	SM Start Cmd	-	BIT	-	-	-	R	VS

27.5 – VDC CONTROL

27.5.1	11100	VDC Control Enable	-	BIT	-	-	-	ERW	VS
27.5.2	11102	Kp Gain VDC control	-	FLOAT	1	0	10000	RW	VS
27.5.3	11104	Ki Gain Vdc control	-	FLOAT	10	0	10000	RW	VS
27.5.4	11106	Voltage Gap for GS1	V	FLOAT	25	0	300	ERW	VS
27.5.5	11108	Kp Amplif for GS1	-	FLOAT	2	0.1	100	ERW	VS
27.5.6	11110	Ki Amplif for GS1	-	FLOAT	1	0.1	100	ERW	VS
27.5.7	11112	GS Filter constant	Hz	FLOAT	0,2	0,02	60	ERW	VS
27.5.8	11120	Acceleration Ramp	-	FLOAT	1	0	1000	ERW	VS
27.5.9	11122	Deceleration Ramp	-	FLOAT	1	0	1000	ERW	VS
27.5.10	12044	Prop Act	-	FLOAT	-	-	-	ER	VS
27.5.11	12046	Int Act	-	FLOAT	-	-	-	ER	VS
27.5.12	12074	KpInUse	-	FLOAT	-	-	-	ER	VS
27.5.13	12076	KtInUse	-	FLOAT	-	-	-	ER	VS

Menu	PAR	Description	UM	Type	FB BIT Def	Min	Max	Acc	Mod
27.6 – MPPT									
27.6.1	11200	MPPT type	-	ENUM	P/O None Threshold	-	-	RW	VS
27.6.2	11202	MPPT Vdc Nom Point	-	FLOAT	520	400	700	RW	VS
27.6.3	11204	MPPT Ramp Acc	V/s	FLOAT	1	-	-	ERW	VS
27.6.4	11206	Min MPPT Vdc Ref	V	FLOAT	400	300	600	RW	VS
27.6.5	11208	Max MPPT Vdc Ref	V	FLOAT	700	300	1000	RW	VS
27.6.6	11210	MPPT Low Sp Off	-	FLOAT	-20	-200	200	ERW	VS
27.6.7	11212	MPPT Med Sp Off	-	FLOAT	-10	-200	200	ERW	VS
27.6.8	11220	Ratio Vmpp Vo	%	FLOAT	80	50	100	ERW	VS
27.6.9	11222	MPPT Trigger count	ms	UINT16	1000	0	60000	ERW	VS
27.6.10	11222	MPPT N of Cnt ch dir	*	WORD	* 10	0	50	RW	VS
27.6.11	11224	MPPT Voltage Step	V/s	FLOAT	2	0	100	ERW	VS
27.6.12	11228	MPPT Right Gain	-	INT16	2	1	10	ERW	VS

27.7 – AUTORESTORE

27.7.1	11250	Auto Restore En	-	BIT	On	-	-	RW	VS
27.7.2	11252	Short Time Restore	s	Float	30	15	3000	RW	VS
27.7.3	11254	Long Time Restore	s	Float	600	15	3000	RW	VS
27.7.4	11256	N of Short Retry		FBM2SIPA	3	-	-	RW	VS
27.7.5	11258	Reset Alarm Mask Low		UINT32	2	-	-	ERW	VS
27.7.6	11260	Reset Alarm Mask Hi		UINT32	-	-	-	ERW	VS
27.7.7	12032	Time to Next Restore	s	Float	-	-	-	R	VS
27.7.8	12034	Number of Retry		FBM2SIPA	-	-	-	R	VS
27.7.9	12036	Time to Retry Reset	s	Float	-	-	-	R	VS

27.8 – STABILITY

27.8.1	11280	En Stability VDC	-	Float	Off	-	-	RW	VS
27.8.2	11282	Speed Red (pc)	-	Float	0.7	0	1	ERW	VS
27.8.3	11284	Min Speed for St cnt	-	Float	2000	0	3000	ERW	VS
27.8.4	11286	Variation of Vdc	-	Float	0.05	0.01	0.5	ERW	VS
27.8.5	11288	Low Value Gain Stab	-	Float	0.1	0.001	0.5	ERW	VS
27.8.6	12040	StabSpeedRef	-	Float	-	-	-	ER	VS

27.9 – MONITOR

27.9.1	12000	Riferimento velocità	-	Float	-	-	-	R	VS
27.9.2	12010	Vdc Set Point Calc	-	Float	-	-	-	R	VS
27.9.3	12012	VDC reference	-	Float	-	-	-	R	VS
27.9.4	12028	MPPT Vdc Direction	-	Float	-	-	-	R	VS
27.9.5	12042	Vdc Filtered	-	Float	-	-	-	R	VS
27.9.6	12066	State Monitor	-	Float	-	-	-	R	VS
				0	LOW RAD				
				1	SOLAR SOURCE				
				2	SOLAR to AC				
				3	AC SOURCE.				
				4	AC to SOLAR				
				5	RAMP				
				6	UNDERVOLTAGE				
				7	NOT READY				
				8	MPPT ON				
				9	VDC CONTROL				
				10	HYBRID SOURCE				

Menu	PAR	Description	UM	Type	FB BIT Def	Min	Max	Acc	Mod
				11	SOLAR > HYBRID				
				12	HYBRID > SOLAR				
27.9.7	12070	DC Connection Req	-	BIT	-	-	-	R	VS
27.9.8	12072	AC Connection Req	-	BIT	-	-	-	R	VS

27.10 – APP INFO

27.10.1	12002	Application Version	-	Float	-	-	-	R	VS
27.10.2	12004	App Build date	-	Float	-	-	-	R	VS
27.10.3	12006	MDPIc Version	-	Float	-	-	-	R	VS
27.10.4	12008	Configurator Version	-	Float	-	-	-	R	VS
27.10.5	12030	Regulation Board SN	-	Float	-	-	-	R	VS

28 - SERVICE

28.1 - SERVICE/TEST GENERATOR

28.1.1	5000	Test gen dest		ENUM	Off	0	4	ERWZ	VS
				0	Off				
				1	Ramp ref 1				
				2	Speed ref 1				
				3	Torque ref 1				
				4	Current ref				
28.1.2	5002	Test gen level high	perc	INT16	0	-200	200	ERW	VS
28.1.3	5004	Test gen level low	perc	INT16	0	-200	200	ERW	VS
28.1.4	5006	Test gen period	s	FLOAT	1.0	0.01	10.0	ERW	VS
28.1.5	5008	Test gen out	perc	INT16	16/32 0	0	0	ER	VS

28.2 - SERVICE/PARAM ADAPT

28.2.1	180	Adapt Rr P gain	perc	FLOAT	1.0	0.01	10.0	ERWS	VS
28.2.2	182	Adapt Rr I time	s	FLOAT	1.0	0.1	10.0	ERWS	VS
28.2.3	184	Adapt Rrlq threshold	A	FLOAT	CALCF	0.0	0.0	ERWZS	VS
28.2.4	170	Adapt RS P gain	perc	FLOAT	2.0	0.01	10.0	ERWS	_S
28.2.5	172	Adapt RS I time	s	FLOAT	0.5	0.1	10.0	ERWS	_S
28.2.6	174	Adapt Rslq threshold	A	FLOAT	CALCF	0.0	0.0	ERWZS	_S

28.3 - SERVICE/FIELDBUS SERV

28.3.1	4016	Fieldbus float order		BIT	0	0	1	ERW	VS
28.3.2	4018	Profibus byte order		BIT	0	0	1	ERW	VS
28.3.3	5604	InputSize		UINT16	0	0	65535	ER	VS
28.3.4	5606	OutputSize		UINT16	0	0	65535	ER	VS
28.3.5	5614	PN diagnostic		UINT32	0	0	4294967295	ERW	VS
28.3.6	30	Display spd filter	ms	UINT16	200	10	1000	ERW	VS

28.4 - SERVICE/SERIAL NUMBERS

28.4.1	520	Product S/N		UINT32	0	0	0	R	VS
28.4.2	522	Regulation S/N		UINT32	0	0	0	R	VS
28.4.3	524	Power S/N		UINT32	0	0	0	R	VS
28.4.4	536	Slot1 card S/N		UINT32	0	0	0	R	VS
28.4.5	538	Slot2 card S/N		UINT32	0	0	0	R	VS
28.4.6	540	Slot3 card S/N		UINT32	0	0	0	R	VS

28.5 - SERVICE/PID AUTOTUNING

28.5.1	8100	PID 1 sys T const	s	FLOAT	20	0.1	600	RW	VS
--------	------	-------------------	---	-------	----	-----	-----	----	----

Menu	PAR	Description	UM	Type	FB BIT Def	Min	Max	Acc	Mod
28.5.2	8102	PID 1 sys K gain		FLOAT	1.0	0.01	200	RW	VS
28.5.3	8104	PID 1 sys delay	s	FLOAT	10.0	0	180	RW	VS
28.5.4	8106	PID 1 tune cycles		INT16	5	1	10	RW	VS
28.5.5	8108	PID 1 tune level		FLOAT	0.9	0.1	0.9	RW	VS
28.5.6	8110	PID 1 N sample delay		INT16	25	1	250	RW	VS
28.5.7	8150	PID 2 sys T const	s	FLOAT	20	0.1	600	RW	VS
28.5.8	8152	PID 2 sys K gain		FLOAT	1.0	0.01	200	RW	VS
28.5.9	8154	PID 2 sys delay	s	FLOAT	10.0	0	180	RW	VS
28.5.10	8156	PID 2 tune cycles		INT16	5	1	10	RW	VS
28.5.11	8158	PID 2 tune level		FLOAT	0.9	0.1	0.9	RW	VS
28.5.12	8160	PID 2 N sample delay		INT16	25	1	250	RW	VS
28.5.13	8190	PID 2 sys ref max		FLOAT	100	0	999999	RW	VS
28.5.14	8192	PID 2 sys T const R	s	FLOAT	20	0.1	1000	RW	VS
28.5.15	8194	PID 2 sys K gain R		FLOAT	1.0	0.01	200	RW	VS
28.5.16	8196	PID 2 sys delay R	s	FLOAT	10.0	0	1000	RW	VS
28.5.17	8198	PID 2 sys ini fbk		FLOAT	0	0	0	RW	VS

28.6 - SERVICE/EXP_SENS CALIBRATION

28.6.1	8000	An inp 1 get 0		BIT	0	0	1	ERW	VS
28.6.2	8002	An inp 1 get max		BIT	0	0	1	ERW	VS
28.6.3	8004	An inp 1 calib		BIT	0	0	1	ERW	VS
28.6.4	8006	An inp 2 get 0		BIT	0	0	1	ERW	VS
28.6.5	8008	An inp 2 get max		BIT	0	0	1	ERW	VS
28.6.6	8010	An inp 2 calib		BIT	0	0	1	ERW	VS
28.6.7	8012	Exp erase flash		BIT	0	0	1	ERW	VS
28.6.8	8014	Exp write flash		BIT	0	0	1	ERW	VS

PARAMETERS NOT PRESENT ON MENU

-	262	Motor speed nofilter	rpm	INT16	16BIT 0	0	0	ER	VS
-	362	Drive overload trip		BIT	16BIT 0	0	1	ER	VS
-	366	Drive overload 80%		BIT	16BIT 0	0	1	ER	VS
-	626	Ramp ref out mon	rpm	INT16	16BIT 0	0	0	ER	VS
-	760	Ramp out mon	rpm	INT16	16BIT 0	0	0	ER	VS
-	764	Ramp acc state		BIT	16BIT 0	0	1	ER	VS
-	766	Ramp dec state		BIT	16BIT 0	0	1	ER	VS
-	934	Ref is 0		BIT	16BIT 0	0	1	ER	VS
-	936	Ref is 0 delay		BIT	16BIT 0	0	1	ER	VS
-	944	Speed is 0		BIT	16BIT 0	0	1	ER	VS
-	946	Speed is 0 delay		BIT	16BIT 0	0	1	ER	VS
-	956	Speed thr 1_2 mon		BIT	16BIT 0	0	1	ER	VS
-	966	Set speed		BIT	16BIT 0	0	1	ER	VS
-	976	Speed thr 3 mon		BIT	16BIT 0	0	1	ER	VS
-	986	Current thr mon		BIT	16BIT 0	0	1	ER	VS
-	1030	Local/remote mon		BIT	16BIT 0	0	1	ER	VS
-	1060	Sequencer status		UINT16	16BIT 0	0	0	ER	VS
-	1062	Drive OK		BIT	16BIT 0	0	1	ER	VS
-	1064	Drive ready		BIT	16BIT 0	0	1	ER	VS
-	1110	Digital input E mon		BIT	16BIT 0	0	1	ER	VS
-	1112	Digital input 1 mon		BIT	16BIT 0	0	1	ER	VS
-	1114	Digital input 2 mon		BIT	16BIT 0	0	1	ER	VS
-	1116	Digital input 3 mon		BIT	16BIT 0	0	1	ER	VS
-	1118	Digital input 4 mon		BIT	16BIT 0	0	1	ER	VS

Menu	PAR	Description	UM	Type	FB BIT Def	Min	Max	Acc	Mod
-	1120	Digital input 5 mon		BIT	16BIT 0	0	1	ER	VS
-	1210	Digital input 1X mon		BIT	16BIT 0	0	1	ER	VS
-	1212	Digital input 2X mon		BIT	16BIT 0	0	1	ER	VS
-	1214	Digital input 3X mon		BIT	16BIT 0	0	1	ER	VS
-	1216	Digital input 4X mon		BIT	16BIT 0	0	1	ER	VS
-	1218	Digital input 5X mon		BIT	16BIT 0	0	1	ER	VS
-	1220	Digital input 6X mon		BIT	16BIT 0	0	1	ER	VS
-	1222	Digital input 7X mon		BIT	16BIT 0	0	1	ER	VS
-	1224	Digital input 8X mon		BIT	16BIT 0	0	1	ER	VS
-	1530	Analog inp1		BIT	16BIT 0	0	1	ER	VS
-	1580	Analog inp2		BIT	16BIT 0	0	1	ER	VS
-	3006	Speed ratio out mon	rpm	INT16	16BIT 0	0	0	ER	VS
-	3180	Brake control mon		BIT	16BIT 0	0	1	ER	VS
-	3214	Motor overload trip		BIT	16BIT 0	0	1	ER	VS
-	3262	Bres overload trip		BIT	16BIT 0	0	1	ER	VS
-	3342	Energysave out run		BIT	16BIT 0	0	1	ER	VS
-	3374	Vf catch out		INT32	16BIT 0	0	0	ER	VS
-	3442	Powerloss rampdown		BIT	16BIT 0	0	1	ER	VS
-	3446	Powerloss nextratio		INT32	32BIT 0	0	0	ER	VS
-	3448	Powerloss nextactive		BIT	16BIT 0	0	1	ER	VS
-	3480	Vdc ctrl ramp freeze		BIT	16BIT 0	0	1	ER	VS
-	4372	DS402 status word		UINT16	16BIT 0	0	65535	ER	VS
-	4394	PFdrv status word 1		UINT16	16BIT 0	0	65535	ER	VS
-	4396	PFdrv status word 2		UINT16	16BIT 0	0	65535	ER	VS
-	4708	Alm dig out mon 1		BIT	16BIT 0	0	1	ER	VS
-	4710	Alm dig out mon 2		BIT	16BIT 0	0	1	ER	VS
-	4712	Alm dig out mon 3		BIT	16BIT 0	0	1	ER	VS
-	4714	Alm dig out mon 4		BIT	16BIT 0	0	1	ER	VS
-	4770	First alarm		UINT32	16BIT 0	0	0	ERW	VS
-	4780	Alarm PLC		UINT16	0	0	0	ER	VS
-	4840	Alarm lo state		UINT32	32BIT 0	0	0	ER	VS
-	4842	Alarm hi state		UINT32	32BIT 0	0	0	ER	VS
-	6000	Null		UINT32	32BIT 0	0	0	ER	VS
-	6002	One		UINT32	32BIT 1	1	1	ER	VS
-	6004	Speed limit state		BIT	16BIT 0	0	1	ER	VS
-	6006	Current limit state		BIT	16BIT 0	0	1	ER	VS

D – SELECTION LISTS

PAR	Description	Menu	PAR	Description	Menu	PAR	Description	Menu
L_ANOUT			3724	Pad 13	22.9.13	3718	Pad 10	22.9.10
6000	Null	(*)	3726	Pad 14	22.9.14	3720	Pad 11	22.9.11
626	Ramp ref out mon	(*)	3728	Pad 15	22.9.15	3722	Pad 12	22.9.12
628	Ramp setpoint	1.5	3730	Pad 16	22.9.16	3724	Pad 13	22.9.13
760	Ramp out mon	(*)	5008	Test gen out	28.1.5	3726	Pad 14	22.9.14
664	Speed setpoint	1.6	7626	PID 1 out	26.2.12	3728	Pad 15	22.9.15
260	Motor speed	1.7	7676	PID 2 out	26.4.12	3730	Pad 16	22.9.16
262	Motor speed nofilter	(*)	L_CMP			7626	PID 1 out	26.2.12
250	Output current	1.1	XXXX (1)			7676	PID 2 out	26.4.12
252	Output voltage	1.2	626	Ramp ref out mon	(*)	<i>(1) the XXXX parameter changes according to the src parameter used:</i>		
254	Output frequency	1.3	628	Ramp setpoint	1.5	960	Set speed ref src	
256	Output power	1.4	760	Ramp out mon	(*)	(1) = 968 Dig set speed ref		10.11
280	Torque current ref	1.11	664	Speed setpoint	1.6	3660	Compare input 1 src	
282	Magnet current ref	1.12	260	Motor speed	1.7	(1) = 3650 Dig compare input 1		22.8.1
284	Torque current	1.13	262	Motor speed nofilter	(*)	3662	Compare input 2 src	
286	Magnet current	1.14	250	Output current	1.1	(1) = 3652 Dig compare input 2		22.8.2
270	DC link voltage	1.8	252	Output voltage	1.2	L_DIGSEL1		
3006	Speed ratio out mon	(*)	254	Output frequency	1.3	6000	Null	(*)
852	Multi ref out mon	7.24	256	Output power	1.4	6002	One	(*)
870	Mpot setpoint	8.1	280	Torque current ref	1.11	1110	Digital input E mon	(*)
894	Mpot output mon	8.13	282	Magnet current ref	1.12	1112	Digital input 1 mon	(*)
920	Jog output mon	9.6	284	Torque current	1.13	1114	Digital input 2 mon	(*)
3104	Inertia comp mon	22.2.3	286	Magnet current	1.14	1116	Digital input 3 mon	(*)
1500	Analog input 1 mon	14.1	270	DC link voltage	1.8	1118	Digital input 4 mon	(*)
1550	Analog input 2 mon	14.17	3006	Speed ratio out mon	(*)	1120	Digital input 5 mon	(*)
1600	Analog input 1X mon	14.33	852	Multi ref out mon	7.24	1210	Digital input 1X mon	(*)
1650	Analog input 2X mon	14.44	870	Mpot setpoint	8.1	1212	Digital input 2X mon	(*)
368	Drive overload accum	1.16	894	Mpot output mon	8.13	1214	Digital input 3X mon	(*)
3212	Motor overload accum	1.15	920	Jog output mon	9.6	1216	Digital input 4X mon	(*)
3260	Bres overload accum	1.17	1500	Analog input 1 mon	14.1	1218	Digital input 5X mon	(*)
2232	Spd reg P gain lnuse	18.11	1550	Analog input 2 mon	14.17	1220	Digital input 6X mon	(*)
2234	Spd reg I gain lnuse	18.12	1600	Analog input 1X mon	14.33	1222	Digital input 7X mon	(*)
3446	Powerloss nexratio	(*)	1650	Analog input 2X mon	14.44	1224	Digital input 8X mon	(*)
3340	Energysave out	22.12.6	368	Drive overload accum	1.16	1062	Drive OK	(*)
4024	Fieldbus M->S1 mon	23.3.3	3212	Motor overload accum	1.15	1064	Drive ready	(*)
4034	Fieldbus M->S2 mon	23.3.7	3260	Bres overload accum	1.17	934	Ref is 0	(*)
4044	Fieldbus M->S3 mon	23.3.11	4024	Fieldbus M->S1 mon	23.3.3	936	Ref is 0 delay	(*)
4054	Fieldbus M->S4 mon	23.3.15	4034	Fieldbus M->S2 mon	23.3.7	944	Speed is 0	(*)
4064	Fieldbus M->S5 mon	23.3.19	4044	Fieldbus M->S3 mon	23.3.11	946	Speed is 0 delay	(*)
4074	Fieldbus M->S6 mon	23.3.23	4054	Fieldbus M->S4 mon	23.3.15	956	Speed thr 1_2 mon	(*)
4084	Fieldbus M->S7 mon	23.3.27	4064	Fieldbus M->S5 mon	23.3.19	966	Set speed	(*)
4094	Fieldbus M->S8 mon	23.3.31	4074	Fieldbus M->S6 mon	23.3.23	976	Speed thr 3 mon	(*)
4104	Fieldbus M->S9 mon	23.3.35	4084	Fieldbus M->S7 mon	23.3.27	986	Current thr mon	(*)
4114	Fieldbus M->S10 mon	23.3.39	4094	Fieldbus M->S8 mon	23.3.31	1066	Enable state mon	1.18
4124	Fieldbus M->S11 mon	23.3.43	4104	Fieldbus M->S9 mon	23.3.35	1068	Start state mon	1.19
4134	Fieldbus M->S12 mon	23.3.47	4114	Fieldbus M->S10 mon	23.3.39	1070	FastStop state mon	1.20
4144	Fieldbus M->S13 mon	23.3.51	4124	Fieldbus M->S11 mon	23.3.43	1024	Enable cmd mon	11.13
4154	Fieldbus M->S14 mon	23.3.55	4134	Fieldbus M->S12 mon	23.3.47	1026	Start cmd mon	11.14
4164	Fieldbus M->S15 mon	23.3.59	4144	Fieldbus M->S13 mon	23.3.51	1028	FastStop cmd mon	11.15
4174	Fieldbus M->S16 mon	23.3.63	4154	Fieldbus M->S14 mon	23.3.55	4708	Alm dig out mon 1	(*)
3700	Pad 1	22.9.1	4164	Fieldbus M->S15 mon	23.3.59	4710	Alm dig out mon 2	(*)
3702	Pad 2	22.9.2	4174	Fieldbus M->S16 mon	23.3.63	4712	Alm dig out mon 3	(*)
3704	Pad 3	22.9.3	3700	Pad 1	22.9.1	4714	Alm dig out mon 4	(*)
3706	Pad 4	22.9.4	3702	Pad 2	22.9.2	1530	Analog inp1<thr	(*)
3708	Pad 5	22.9.5	3704	Pad 3	22.9.3	1580	Analog inp2<thr	(*)
3710	Pad 6	22.9.6	3706	Pad 4	22.9.4	362	Drive overload trip	(*)
3712	Pad 7	22.9.7	3708	Pad 5	22.9.5			
3714	Pad 8	22.9.8	3710	Pad 6	22.9.6			
3716	Pad 9	22.9.9	3712	Pad 7	22.9.7			
3718	Pad 10	22.9.10	3714	Pad 8	22.9.8			
3720	Pad 11	22.9.11	3716	Pad 9	22.9.9			
3722	Pad 12	22.9.12						

PAR	Description	Menu	PAR	Description	Menu	PAR	Description	Menu
3214	Motor overload trip	(*)	7848	Fire bypass mon	26.12.5	3676	Compare output	22.8.8
3262	Bres overload trip	(*)	7850	Fire out mon	26.12.6	3480	Vdc ctrl ramp freeze	(*)
366	Drive overload 80%	(*)	7912	Timer1 status mon	26.13.27	7912	Timer1 status mon	26.13.27
1048	FR start mon	11.20	7918	Timer2 status mon	26.13.30	7918	Timer2 status mon	26.13.30
1050	FR reverse mon	11.21	7924	Timer3 status mon	26.13.33	7924	Timer3 status mon	26.13.33
4454	Bit0 decomp mon	23.6.3	7930	Timer4 status mon	26.13.36	7930	Timer4 status mon	26.13.36
4456	Bit1 decomp mon	23.6.4	7814	Clean active mon	26.10.16	3342	Energysave out run	(*)
4458	Bit2 decomp mon	23.6.5	7462	Sleep active mon	26.5.12			
4460	Bit3 decomp mon	23.6.6						
4462	Bit4 decomp mon	23.6.7						
4464	Bit5 decomp mon	23.6.8						
4466	Bit6 decomp mon	23.6.9						
4468	Bit7 decomp mon	23.6.10						
4470	Bit8 decomp mon	23.6.11						
4472	Bit9 decomp mon	23.6.12						
4474	Bit10 decomp mon	23.6.13						
4476	Bit11 decomp mon	23.6.14						
4478	Bit12 decomp mon	23.6.15						
4480	Bit13 decomp mon	23.6.16						
4482	Bit14 decomp mon	23.6.17						
4484	Bit15 decomp mon	23.6.18						
3700	Pad 1	22.9.1						
3702	Pad 2	22.9.2						
3704	Pad 3	22.9.3						
3706	Pad 4	22.9.4						
3708	Pad 5	22.9.5						
3710	Pad 6	22.9.6						
3712	Pad 7	22.9.7						
3714	Pad 8	22.9.8						
3716	Pad 9	22.9.9						
3718	Pad 10	22.9.10						
3720	Pad 11	22.9.11						
3722	Pad 12	22.9.12						
3724	Pad 13	22.9.13						
3726	Pad 14	22.9.14						
3728	Pad 15	22.9.15						
3730	Pad 16	22.9.16						
6004	Speed limit state	(*)	6000	Null	(*)	6000	Null	(*)
6006	Current limit state	(*)	6002	One	(*)	6002	One	(*)
764	Ramp acc state	(*)	1110	Digital input E mon	(*)	1110	Digital input E mon	(*)
766	Ramp dec state	(*)	1112	Digital input 1 mon	(*)	1112	Digital input 1 mon	(*)
1030	Local/remote mon	(*)	1114	Digital input 2 mon	(*)	1114	Digital input 2 mon	(*)
4780	Alarm PLC	(*)	1116	Digital input 3 mon	(*)	1116	Digital input 3 mon	(*)
3676	Compare output	22.8.8	1118	Digital input 4 mon	(*)	1118	Digital input 4 mon	(*)
3442	Powerloss rampdown	(*)	1120	Digital input 5 mon	(*)	1120	Digital input 5 mon	(*)
3448	Powerloss nextactive	(*)	1210	Digital input 1X mon	(*)	1210	Digital input 1X mon	(*)
3180	Brake control mon	(*)	1212	Digital input 2X mon	(*)	1212	Digital input 2X mon	(*)
7150	Pump 1 out mon	26.14.24	1214	Digital input 3X mon	(*)	1214	Digital input 3X mon	(*)
7152	Pump 2 out mon	26.14.25	1216	Digital input 4X mon	(*)	1216	Digital input 4X mon	(*)
7154	Pump 3 out mon	26.14.26	1218	Digital input 5X mon	(*)	1218	Digital input 5X mon	(*)
7156	Pump 4 out mon	26.14.27	1220	Digital input 6X mon	(*)	1220	Digital input 6X mon	(*)
7158	Pump 5 out mon	26.14.28	1222	Digital input 7X mon	(*)	1222	Digital input 7X mon	(*)
7160	Pump 6 out mon	26.14.29	1224	Digital input 8X mon	(*)	1224	Digital input 8X mon	(*)
7162	Pump 7 out mon	26.14.30	4454	Bit0 decomp mon	23.6.3	1062	Drive OK	(*)
7164	Pump 8 out mon	26.14.31	4456	Bit1 decomp mon	23.6.4	1064	Drive ready	(*)
7170	Pump 1 lead mon	26.14.32	4458	Bit2 decomp mon	23.6.5	934	Ref is 0	(*)
7172	Pump 2 lead mon	26.14.33	4460	Bit3 decomp mon	23.6.6	936	Ref is 0 delay	(*)
7174	Pump 3 lead mon	26.14.34	4462	Bit4 decomp mon	23.6.7	944	Speed is 0	(*)
7176	Pump 4 lead mon	26.14.35	4464	Bit5 decomp mon	23.6.8	946	Speed is 0 delay	(*)
7178	Pump 5 lead mon	26.14.36	4466	Bit6 decomp mon	23.6.9	956	Speed thr 1_2 mon	(*)
7180	Pump 6 lead mon	26.14.37	4468	Bit7 decomp mon	23.6.10	966	Set speed	(*)
7182	Pump 7 lead mon	26.14.38	4470	Bit8 decomp mon	23.6.11	976	Speed thr 3 mon	(*)
7184	Pump 8 lead mon	26.14.39	4472	Bit9 decomp mon	23.6.12	986	Current thr mon	(*)
			4474	Bit10 decomp mon	23.6.13	1066	Enable state mon	1.18
			4476	Bit11 decomp mon	23.6.14	1068	Start state mon	1.19
			4478	Bit12 decomp mon	23.6.15	1070	FastStop state mon	1.20
			4480	Bit13 decomp mon	23.6.16	1024	Enable cmd mon	11.13
			4482	Bit14 decomp mon	23.6.17	1026	Start cmd mon	11.14
			4484	Bit15 decomp mon	23.6.18	1028	FastStop cmd mon	11.15
			3700	Pad 1	22.9.1	4708	Alm dig out mon 1	(*)
			3702	Pad 2	22.9.2	4710	Alm dig out mon 2	(*)
			3704	Pad 3	22.9.3	4712	Alm dig out mon 3	(*)
			3706	Pad 4	22.9.4	4714	Alm dig out mon 4	(*)
			3708	Pad 5	22.9.5	1530	Analog inp1<thr	(*)
			3710	Pad 6	22.9.6	1580	Analog inp2<thr	(*)
			3712	Pad 7	22.9.7	362	Drive overload trip	(*)
			3714	Pad 8	22.9.8	3214	Motor overload trip	(*)
			3716	Pad 9	22.9.9	3262	Bres overload trip	(*)
			3718	Pad 10	22.9.10	366	Drive overload 80%	(*)
			3720	Pad 11	22.9.11	1048	FR start mon	11.20
			3722	Pad 12	22.9.12	1050	FR reverse mon	11.21
			3724	Pad 13	22.9.13	4454	Bit0 decomp mon	23.6.3
			3726	Pad 14	22.9.14	4456	Bit1 decomp mon	23.6.4
			3728	Pad 15	22.9.15	4458	Bit2 decomp mon	23.6.5
			3730	Pad 16	22.9.16	4460	Bit3 decomp mon	23.6.6
			1530	Analog inp1<thr	(*)	4462	Bit4 decomp mon	23.6.7
			1580	Analog inp2<thr	(*)	4464	Bit5 decomp mon	23.6.8
			1048	FR start mon	11.20	4466	Bit6 decomp mon	23.6.9
			1050	FR reverse mon	11.21	4468	Bit7 decomp mon	23.6.10

L_DIGSEL2

L_DIGSEL3

XXXX (2)

PAR	Description	Menu
4470	Bit8 decomp mon	23.6.11
4472	Bit9 decomp mon	23.6.12
4474	Bit10 decomp mon	23.6.13
4476	Bit11 decomp mon	23.6.14
4478	Bit12 decomp mon	23.6.15
4480	Bit13 decomp mon	23.6.16
4482	Bit14 decomp mon	23.6.17
4484	Bit15 decomp mon	23.6.18
3700	Pad 1	22.9.1
3702	Pad 2	22.9.2
3704	Pad 3	22.9.3
3706	Pad 4	22.9.4
3708	Pad 5	22.9.5
3710	Pad 6	22.9.6
3712	Pad 7	22.9.7
3714	Pad 8	22.9.8
3716	Pad 9	22.9.9
3718	Pad 10	22.9.10
3720	Pad 11	22.9.11
3722	Pad 12	22.9.12
3724	Pad 13	22.9.13
3726	Pad 14	22.9.14
3728	Pad 15	22.9.15
3730	Pad 16	22.9.16
6004	Speed limit state	(*)
6006	Current limit state	(*)
764	Ramp acc state	(*)
766	Ramp dec state	(*)
4780	Alarm PLC	(*)
3676	Compare output	22.8.8

(2) the XXXX parameter changes according to the src parameter used:

1014 Local/remote src
(2) = 1012 Dig local/remote 11.7

7492 Fill enable src
(2) = 7470 Fill enable 26.7.1

L_DIGSEL4

6000	Null	(*)
6002	One	(*)
1110	Digital input E mon	(*)
1112	Digital input 1 mon	(*)
1114	Digital input 2 mon	(*)
1116	Digital input 3 mon	(*)
1118	Digital input 4 mon	(*)
1120	Digital input 5 mon	(*)
1210	Digital input 1X mon	(*)
1212	Digital input 2X mon	(*)
1214	Digital input 3X mon	(*)
1216	Digital input 4X mon	(*)
1218	Digital input 5X mon	(*)
1220	Digital input 6X mon	(*)
1222	Digital input 7X mon	(*)
1224	Digital input 8X mon	(*)
1062	Drive OK	(*)
1064	Drive ready	(*)

L_FBS2M

XXXX	(3)	
6000	Null	(*)
6002	One	(*)
626	Ramp ref out mon	(*)
628	Ramp setpoint	1.5
760	Ramp out mon	(*)
664	Speed setpoint	1.6
260	Motor speed	1.7
262	Motor speed nofilter	(*)
250	Output current	1.1
252	Output voltage	1.2
254	Output frequency	1.3
280	Torque current ref	1.11
282	Magnet current ref	1.12
284	Torque current	1.13
286	Magnet current	1.14
270	DC link voltage	1.8
3006	Speed ratio out mon	(*)
852	Multi ref out mon	7.24
870	Mpot setpoint	8.1
894	Mpot output mon	8.13
920	Jog output mon	9.6
3104	Inertia comp mon	22.2.3
1500	Analog input 1 mon	14.1
1550	Analog input 2 mon	14.17
1600	Analog input 1X mon	14.33
1650	Analog input 2X mon	14.44
368	Drive overload accum	1.16
3212	Motor overload accum	1.15
3260	Bres overload accum	1.17
272	Heatsink temperature	1.9
1060	Sequencer status	(*)
4432	Word comp mon	23.5.17
3446	Powerloss nextratio	(*)
4372	DS402 status word	(*)
4394	PFdrv status word 1	(*)
4396	PFdrv status word 2	(*)
4024	Fieldbus M->S1 mon	23.3.3
4034	Fieldbus M->S2 mon	23.3.7
4044	Fieldbus M->S3 mon	23.3.11
4054	Fieldbus M->S4 mon	23.3.15
4064	Fieldbus M->S5 mon	23.3.19
4074	Fieldbus M->S6 mon	23.3.23
4084	Fieldbus M->S7 mon	23.3.27
4094	Fieldbus M->S8 mon	23.3.31
4104	Fieldbus M->S9 mon	23.3.35
4114	Fieldbus M->S10 mon	23.3.39
4124	Fieldbus M->S11 mon	23.3.43
4134	Fieldbus M->S12 mon	23.3.47
4144	Fieldbus M->S13 mon	23.3.51
4154	Fieldbus M->S14 mon	23.3.55
4164	Fieldbus M->S15 mon	23.3.59
4174	Fieldbus M->S16 mon	23.3.63
3700	Pad 1	22.9.1
3702	Pad 2	22.9.2
3704	Pad 3	22.9.3
3706	Pad 4	22.9.4
3708	Pad 5	22.9.5
3710	Pad 6	22.9.6
3712	Pad 7	22.9.7
3714	Pad 8	22.9.8

PAR	Description	Menu
3716	Pad 9	22.9.9
3718	Pad 10	22.9.10
3720	Pad 11	22.9.11
3722	Pad 12	22.9.12
3724	Pad 13	22.9.13
3726	Pad 14	22.9.14
3728	Pad 15	22.9.15
3730	Pad 16	22.9.16
4770	First alarm	(*)
4840	Alarm lo state	(*)
4842	Alarm hi state	(*)
1100	Digital input mon	1.21
1200	Digital input X mon	1.23
5008	Test gen out	28.1.5

3) the XXXX parameter changes according to the src parameter used:

4340 DS402 cw src
(3) = 4024 Fieldbus M->S1 mon 23.3.3

4346 PFdrv cw 1 src
(3) = 4024 Fieldbus M->S1 mon 23.3.3

4348 PFdrv cw 2 src
(3) = 4034 Fieldbus M->S2 mon 23.3.7

L_LIM

6000	Null	(*)
1500	Analog input 1 mon	14.1
1550	Analog input 2 mon	14.17
1600	Analog input 1X mon	14.33
1650	Analog input 2X mon	14.44
4024	Fieldbus M->S1 mon	23.3.3
4034	Fieldbus M->S2 mon	23.3.7
4044	Fieldbus M->S3 mon	23.3.11
4054	Fieldbus M->S4 mon	23.3.15
4064	Fieldbus M->S5 mon	23.3.19
4074	Fieldbus M->S6 mon	23.3.23
4084	Fieldbus M->S7 mon	23.3.27
4094	Fieldbus M->S8 mon	23.3.31
4104	Fieldbus M->S9 mon	23.3.35
4114	Fieldbus M->S10 mon	23.3.39
4124	Fieldbus M->S11 mon	23.3.43
4134	Fieldbus M->S12 mon	23.3.47
4144	Fieldbus M->S13 mon	23.3.51
4154	Fieldbus M->S14 mon	23.3.55
4164	Fieldbus M->S15 mon	23.3.59
4174	Fieldbus M->S16 mon	23.3.63
3700	Pad 1	22.9.1
3702	Pad 2	22.9.2
3704	Pad 3	22.9.3
3706	Pad 4	22.9.4
3708	Pad 5	22.9.5
3710	Pad 6	22.9.6
3712	Pad 7	22.9.7
3714	Pad 8	22.9.8
3716	Pad 9	22.9.9
3718	Pad 10	22.9.10
3720	Pad 11	22.9.11
3722	Pad 12	22.9.12
3724	Pad 13	22.9.13

PAR	Description	Menu
3726	Pad 14	22.9.14
3728	Pad 15	22.9.15
3730	Pad 16	22.9.16
5008	Test gen out	28.1.5

L_MLTREF

PAR	Description	Menu
XXXX (4)		
1500	Analog input 1 mon	14.1
1550	Analog input 2 mon	14.17
852	Multi ref out mon	7.24
894	Mpot output mon	8.13
1600	Analog input 1X mon	14.33
1650	Analog input 2X mon	14.44
4024	Fieldbus M->S1 mon	23.3.3
4034	Fieldbus M->S2 mon	23.3.7
4044	Fieldbus M->S3 mon	23.3.11
4054	Fieldbus M->S4 mon	23.3.15
4064	Fieldbus M->S5 mon	23.3.19
4074	Fieldbus M->S6 mon	23.3.23
4084	Fieldbus M->S7 mon	23.3.27
4094	Fieldbus M->S8 mon	23.3.31
4104	Fieldbus M->S9 mon	23.3.35
4114	Fieldbus M->S10 mon	23.3.39
4124	Fieldbus M->S11 mon	23.3.43
4134	Fieldbus M->S12 mon	23.3.47
4144	Fieldbus M->S13 mon	23.3.51
4154	Fieldbus M->S14 mon	23.3.55
4164	Fieldbus M->S15 mon	23.3.59
4174	Fieldbus M->S16 mon	23.3.63
3700	Pad 1	22.9.1
3702	Pad 2	22.9.2
3704	Pad 3	22.9.3
3706	Pad 4	22.9.4
3708	Pad 5	22.9.5
3710	Pad 6	22.9.6
3712	Pad 7	22.9.7
3714	Pad 8	22.9.8
3716	Pad 9	22.9.9
3718	Pad 10	22.9.10
3720	Pad 11	22.9.11
3722	Pad 12	22.9.12
3724	Pad 13	22.9.13
3726	Pad 14	22.9.14
3728	Pad 15	22.9.15
3730	Pad 16	22.9.16
5008	Test gen out	28.1.5
7626	PID 1 out	26.2.12
7676	PID 2 out	26.4.12

(4) the XXXX parameter changes according to the src parameter used:

610 Ramp ref 1 src
(4) = 600 Dig ramp ref 1 5.1

612 Ramp ref 2 src
(4) = 602 Dig ramp ref 2 5.2

614 Ramp ref 3 src
(4) = 604 Dig ramp ref 3 5.3

PAR	Description	Menu
650	Speed ref 1 src (4) = 640 Dig speed ref 1	5.19

652 Speed ref 2 src
(4) = 642 Dig speed ref 2 5.20

832 Multi ref 0 src
(4) = 800 Multi reference 0 7.1

834 Multi ref 1 src
(4) = 802 Multi reference 1 7.2

L_PIDFBK

PAR	Description	Menu
6000	Null (*)	
1500	Analog input 1 mon	14.1
1550	Analog input 2 mon	14.17
1600	Analog input 1X mon	14.33
1650	Analog input 2X mon	14.44
7520	FC ref out mon	26.6.11
4024	Fieldbus M->S1 mon	23.3.3
4034	Fieldbus M->S2 mon	23.3.7
4044	Fieldbus M->S3 mon	23.3.11
4054	Fieldbus M->S4 mon	23.3.15
4064	Fieldbus M->S5 mon	23.3.19
4074	Fieldbus M->S6 mon	23.3.23
4084	Fieldbus M->S7 mon	23.3.27
4094	Fieldbus M->S8 mon	23.3.31
4104	Fieldbus M->S9 mon	23.3.35
4114	Fieldbus M->S10 mon	23.3.39
4124	Fieldbus M->S11 mon	23.3.43
4134	Fieldbus M->S12 mon	23.3.47
4144	Fieldbus M->S13 mon	23.3.51
4154	Fieldbus M->S14 mon	23.3.55
4164	Fieldbus M->S15 mon	23.3.59
4174	Fieldbus M->S16 mon	23.3.63
3700	Pad 1	22.9.1
3702	Pad 2	22.9.2
3704	Pad 3	22.9.3
3706	Pad 4	22.9.4
3708	Pad 5	22.9.5
3710	Pad 6	22.9.6
3712	Pad 7	22.9.7
3714	Pad 8	22.9.8
3716	Pad 9	22.9.9
3718	Pad 10	22.9.10
3720	Pad 11	22.9.11
3722	Pad 12	22.9.12
3724	Pad 13	22.9.13
3726	Pad 14	22.9.14
3728	Pad 15	22.9.15
3730	Pad 16	22.9.16
5008	Test gen out	28.1.5

L_PIDREF

PAR	Description	Menu
XXXX (5)		
1500	Analog input 1 mon	14.1
1550	Analog input 2 mon	14.17
1600	Analog input 1X mon	14.33
1650	Analog input 2X mon	14.44
7520	FC ref out mon	26.6.11

PAR	Description	Menu
4024	Fieldbus M->S1 mon	23.3.3
4034	Fieldbus M->S2 mon	23.3.7
4044	Fieldbus M->S3 mon	23.3.11
4054	Fieldbus M->S4 mon	23.3.15
4064	Fieldbus M->S5 mon	23.3.19
4074	Fieldbus M->S6 mon	23.3.23
4084	Fieldbus M->S7 mon	23.3.27
4094	Fieldbus M->S8 mon	23.3.31
4104	Fieldbus M->S9 mon	23.3.35
4114	Fieldbus M->S10 mon	23.3.39
4124	Fieldbus M->S11 mon	23.3.43
4134	Fieldbus M->S12 mon	23.3.47
4144	Fieldbus M->S13 mon	23.3.51
4154	Fieldbus M->S14 mon	23.3.55
4164	Fieldbus M->S15 mon	23.3.59
4174	Fieldbus M->S16 mon	23.3.63
3700	Pad 1	22.9.1
3702	Pad 2	22.9.2
3704	Pad 3	22.9.3
3706	Pad 4	22.9.4
3708	Pad 5	22.9.5
3710	Pad 6	22.9.6
3712	Pad 7	22.9.7
3714	Pad 8	22.9.8
3716	Pad 9	22.9.9
3718	Pad 10	22.9.10
3720	Pad 11	22.9.11
3722	Pad 12	22.9.12
3724	Pad 13	22.9.13
3726	Pad 14	22.9.14
3728	Pad 15	22.9.15
3730	Pad 16	22.9.16
5008	Test gen out	28.1.5

5) the XXXX parameter changes according to the src parameter used:

7302 PID 1 ref 1 src
(5) = 7300 PID 1 dig ref 1 26.1.1

7306 PID 1 ref 2 src
(5) = 7304 PID 1 dig ref 2 26.1.3

7352 PID 2 ref 1 src
(5) = 7350 PID 2 dig ref 1 26.3.1

7356 PID 2 ref 2 src
(5) = 7354 PID 2 dig ref 2 26.3.1

L_REF

PAR	Description	Menu
1500	Analog input 1 mon	14.1
1550	Analog input 2 mon	14.17
626	Ramp ref out mon	(*)
664	Speed setpoint	1.6
262	Motor speed nofilter	(*)
1600	Analog input 1X mon	14.33
1650	Analog input 2X mon	14.44
4024	Fieldbus M->S1 mon	23.3.3
4034	Fieldbus M->S2 mon	23.3.7
4044	Fieldbus M->S3 mon	23.3.11
4054	Fieldbus M->S4 mon	23.3.15

PAR	Description	Menu	PAR	Description	Menu	PAR	Description	Menu
4064	Fieldbus M->S5 mon	23.3.19	3702	Pad 2	22.9.2	3722	Pad 12	22.9.12
4074	Fieldbus M->S6 mon	23.3.23	3704	Pad 3	22.9.3	3724	Pad 13	22.9.13
4084	Fieldbus M->S7 mon	23.3.27	3706	Pad 4	22.9.4	3726	Pad 14	22.9.14
4094	Fieldbus M->S8 mon	23.3.31	3708	Pad 5	22.9.5	3728	Pad 15	22.9.15
4104	Fieldbus M->S9 mon	23.3.35	3710	Pad 6	22.9.6	3730	Pad 16	22.9.16
4114	Fieldbus M->S10 mon	23.3.39	3712	Pad 7	22.9.7			
4124	Fieldbus M->S11 mon	23.3.43	3714	Pad 8	22.9.8			
4134	Fieldbus M->S12 mon	23.3.47	3716	Pad 9	22.9.9			
4144	Fieldbus M->S13 mon	23.3.51	3718	Pad 10	22.9.10			
4154	Fieldbus M->S14 mon	23.3.55	3720	Pad 11	22.9.11			
4164	Fieldbus M->S15 mon	23.3.59	3722	Pad 12	22.9.12			
4174	Fieldbus M->S16 mon	23.3.63	3724	Pad 13	22.9.13			
3700	Pad 1	22.9.1	3726	Pad 14	22.9.14			
3702	Pad 2	22.9.2	3728	Pad 15	22.9.15			
3704	Pad 3	22.9.3	3730	Pad 16	22.9.16			
3706	Pad 4	22.9.4	6000	Null	(*)			
3708	Pad 5	22.9.5	5008	Test gen out	28.1.5			
3710	Pad 6	22.9.6						
3712	Pad 7	22.9.7						
3714	Pad 8	22.9.8						
3716	Pad 9	22.9.9						
3718	Pad 10	22.9.10						
3720	Pad 11	22.9.11						
3722	Pad 12	22.9.12						
3724	Pad 13	22.9.13						
3726	Pad 14	22.9.14						
3728	Pad 15	22.9.15						
3730	Pad 16	22.9.16						
5008	Test gen out	28.1.5						
7626	PID 1 out	26.2.12						
7676	PID 2 out	26.4.12						

(7) the XXXX parameter changes according to the src parameter used:

4452 Word decomp src
(7) = 4450 Dig word decomp 23.6.1

(*) Parameter not shown on the keypad.
For information see the "PARAMETERS INCLUDED IN SELECTION LISTS BUT NOT SHOWN ON THE KEYPAD" section.

(6) the XXXX parameter changes according to the src parameter used:

2492 Vf scale src
(6) = 2490 Dig Vf scale 21.22

3002 Speed ratio src
(6) = 3000 Dig speed ratio 22.1.1

L_WDECOMP

XXXX	(7)	
6000	Null	(*)
6002	One	(*)
4432	Word comp mon	23.5.17
1600	Analog input 1X mon	14.33
1650	Analog input 2X mon	14.44
4024	Fieldbus M->S1 mon	23.3.3
4034	Fieldbus M->S2 mon	23.3.7
4044	Fieldbus M->S3 mon	23.3.11
4054	Fieldbus M->S4 mon	23.3.15
4064	Fieldbus M->S5 mon	23.3.19
4074	Fieldbus M->S6 mon	23.3.23
4084	Fieldbus M->S7 mon	23.3.27
4094	Fieldbus M->S8 mon	23.3.31
4104	Fieldbus M->S9 mon	23.3.35
4114	Fieldbus M->S10 mon	23.3.39
4124	Fieldbus M->S11 mon	23.3.43
4134	Fieldbus M->S12 mon	23.3.47
4144	Fieldbus M->S13 mon	23.3.51
4154	Fieldbus M->S14 mon	23.3.55
4164	Fieldbus M->S15 mon	23.3.59
4174	Fieldbus M->S16 mon	23.3.63
3700	Pad 1	22.9.1
3702	Pad 2	22.9.2
3704	Pad 3	22.9.3
3706	Pad 4	22.9.4
3708	Pad 5	22.9.5
3710	Pad 6	22.9.6
3712	Pad 7	22.9.7
3714	Pad 8	22.9.8
3716	Pad 9	22.9.9
3718	Pad 10	22.9.10
3720	Pad 11	22.9.11

L_SCOPE

6000 Null (*)

L_VREF

XXXX	(6)	
3104	Inertia comp mon	22.2.3
3374	Vf catch out	(*)
1500	Analog input 1 mon	14.1
1550	Analog input 2 mon	14.17
1600	Analog input 1X mon	14.33
1650	Analog input 2X mon	14.44
4024	Fieldbus M->S1 mon	23.3.3
4034	Fieldbus M->S2 mon	23.3.7
4044	Fieldbus M->S3 mon	23.3.11
4054	Fieldbus M->S4 mon	23.3.15
4064	Fieldbus M->S5 mon	23.3.19
4074	Fieldbus M->S6 mon	23.3.23
4084	Fieldbus M->S7 mon	23.3.27
4094	Fieldbus M->S8 mon	23.3.31
4104	Fieldbus M->S9 mon	23.3.35
4114	Fieldbus M->S10 mon	23.3.39
4124	Fieldbus M->S11 mon	23.3.43
4134	Fieldbus M->S12 mon	23.3.47
4144	Fieldbus M->S13 mon	23.3.51
4154	Fieldbus M->S14 mon	23.3.55
4164	Fieldbus M->S15 mon	23.3.59
4174	Fieldbus M->S16 mon	23.3.63
3700	Pad 1	22.9.1

E – TROUBLESHOOTING - Alarms

Note ! To reset alarms, see Quick start guide, **paragraph 6.6.1**.
In the following table, the Code is visible only from serial line.

Code	Error message shown on the display	Sub-code	Description
0	No alarm		Condition: No alarm present
1	Overvoltage		Condition: DC link overvoltage alarm due to energy recovered from the motor. The voltage arriving at the drive power section is too high compared to the maximum threshold relating to the PAR 560 Mains voltage parameter setting.
			Solution: - Extend the deceleration ramp. - Use a braking resistor between terminals BR1 and BR2 to dissipate the recovered energy - Use the VDC Control function
2	Undervoltage		Condition: DC link undervoltage alarm. The voltage arriving at the drive power section is too low compared to the minimum threshold relating to the PAR 560 Mains voltage parameter setting due to: - the mains voltage being too low or overextended voltage drops. - poor cable connections (e.g. loose contactor terminals, inductance, filter, etc.).
			Solution: Check the connections.
3	Ground fault		Condition: Ground short circuit alarm
			Solution: - Check drive and motor wiring. - Check that the motor is not grounded.
4	Overcurrent		Condition: Instantaneous overcurrent protection intervention alarm. This may be due to the incorrect setting of current regulator parameters or a short circuit between phases or ground fault on the drive output.
			Solution: - Check the current regulator parameters - Check wiring towards the motor
5	Desaturation		Condition: Instantaneous overcurrent in the IGBT bridge alarm.
			Solution: Switch the drive off and then switch it on again. If the alarm persists, contact the technical service centre.
6	MultiUndervolt		Condition: The number of attempted automatic restarts after the Undervoltage alarm has exceeded the set PAR 4650 UVRep attempts value in the PAR 4652 UVRep delay time.
			Solution: Too many Undervoltage alarms. Adopt the proposed solutions for the Undervoltage alarm.
7	MultiOvercurr		Condition: 2 attempted automatic restarts after the Overcurrent alarm within 30 seconds. If more than 30 seconds pass after the Overcurrent alarm was generated, the attempt counter is reset.
			Solution: Too many Overcurrent alarms. Adopt the proposed solutions for the Overcurrent alarm.
8	MultiDesat		Condition: 2 attempted at automatic restarts after the Desaturation alarm within 30 seconds. If more than 30 seconds pass after the Desaturation alarm was generated, the attempt counter is reset.
			Solution: Too many Desaturation alarms. Adopt the proposed solutions for the Desaturation alarm.
9	Heatsink OT		Condition: Heatsink temperature too high alarm
			Solution: - Verify the correct operation of the cooling fan. - Check that the heatsinks are not clogged
10	Heatsinks OTUT		Condition: Heatsink temperature too high or too low alarm The temperature has exceeded the upper or lower limit set for the linear temperature transducer.
			Solution: - Verify the correct operation of the cooling fan. - Check that the heatsinks are not clogged - Check that the openings for the cabinet cooling air are not blocked.
11	Intakeair OT		Condition: Intake air temperature too high alarm.
			Solution: Check correct fan operation

Code	Error message shown on the display	Sub-code	Description
12	Motor OT	<p>Condition: Motor overtemperature alarm. Possible causes:</p> <ul style="list-style-type: none"> - Load cycle too heavy - The motor is installed in a place where the ambient temperature is too high - If the motor is provided with a blower: the fan is not working - If the motor is not provided with a blower: the load is too high at slow speeds. Cooling the fan on the motor shaft is not sufficient for this load cycle. - The motor is used at less than the rated frequency, causing additional magnetic losses. 	
		<p>Solution:</p> <ul style="list-style-type: none"> - Change the processing cycle. - Use a cooling fan to cool the motor. 	
13	Drive overload	<p>Condition: Drive overload alarm. The overload threshold of the accumulator of the I²t drive thermal image has been exceeded.</p>	
		<p>Solution: Check that the size of the drive is suitable for the application.</p>	
14	Motor overload	<p>Condition: Motor overload alarm. The current absorbed during operation is greater than that specified on the motor data plate. The overload threshold of the accumulator of the I²t motor thermal image has been exceeded.</p>	
		<p>Solution:</p> <ul style="list-style-type: none"> - Reduce the motor load. - Increase the size of the motor. 	
15	Bres overload	<p>Condition: Braking resistor overload alarm. The current absorbed by the resistor is greater than the rated current. The overload threshold of the accumulator of the I²t braking resistor thermal image has been exceeded.</p>	
		<p>Solution: Increase the Watt value of the braking resistor</p>	
16	Phaseloss	<p>Condition: Power phase loss alarm.</p>	
		<p>Solution: Check the mains voltage and whether any protections upstream of the drive have been tripped.</p>	
17	Opt Bus fault	<p>Condition: Error in the configuration stage or communication error.</p>	
		XXX0H-X	If the first digit to the left of "H" in the alarm sub-code is 0, the error regards a communication problem.
		XXXXH-X	If the first digit to the left of "H" in the alarm sub-code is other than 0, the error regards a configuration problem.
		<p>Solution: For configuration errors, check the configuration of the bus communication, type of bus, baudrate, address, parameter setting. For communication errors verify wiring, resistance of terminations, interference immunity, timeout settings. For further details, please refer to the user guide for the specific bus.</p>	
18	Opt 1 I/O fault	<p>Condition: Error in the communication between Regulation and I/O expansion card in slot 1</p>	
		<p>Solution: Check that it has been inserted correctly, see chapter 11.5.</p>	
19	Opt 2 I/O fault	<p>Condition: Error in the communication between Regulation and I/O expansion card in slot 2 or 3</p>	
		<p>Solution: Check that it has been inserted correctly, see chapter 11.5.</p>	
20	Not Used 1		
21	External fault	<p>Condition: External alarm present. A digital input has been programmed as an external alarm, but the +24V voltage is not available on the terminal.</p>	
		<p>Solution: Check that the terminal screws are tight</p>	
22	Not Used 2		
23	Overspeed	<p>Condition: Motor overspeed alarm. The motor speed exceeds the limits set in the PAR 4540 Overspeed threshold</p>	
		<p>Solution:</p> <ul style="list-style-type: none"> - Limit the speed reference. - Check that the motor is not driven in overspeed during rotation. 	
24	Speed ref loss	<p>Condition: Speed reference loss alarm; occurs if the difference between the speed regulator reference and the actual motor speed is more than 100 rpm. This condition occurs because the drive is in the current limit condition. It is only available in the Flux Vect OL mode.</p>	
		<p>Solution: Check the drive load conditions</p>	

Code	Error message shown on the display	Sub-code	Description
25	Emg stop alarm	Condition: Emergency stop alarm. The Stop key on the keypad was pressed with the Stop key mode parameter set to EmgStop&Alarm in case of Remote-> Terminal Strip or Remote-> Digital or Local-> Terminal Strip mode.	
		Solution: Eliminate the reason for which the Stop key on the keypad was pressed and reset the drive.	
26	Power down	Condition: The drive was enabled with no supply voltage at the power section.	
		Solution: Check the drive power supply	
27	Broken belt	Condition: Occurs if torque required from motor falls below a programmed threshold (PAR 7702) and if speed exceeds a programmed threshold (PAR 7706).	
		Solution: Check system mechanics.	
28	End curve	Condition: The value of the feedback signal (for example, pressure transducer) is below the reference value and rotation speed is higher than the threshold set in parameter 7712. The alarm is generated if this condition persists for a time equal to the value set in parameter 7714.	
		Solution: <ul style="list-style-type: none"> • Check configuration of parameters on menu 26.11. • Check for system leakages. • Check the feedback sensor. 	
29 30	Dry pump No flow	Condition: The value of delivered power (parameter 7752) is below the limits defined by the minimum power curve.	
		Solution: <ul style="list-style-type: none"> • Check configuration of parameters on menu 26.11. • Check for system leakages. 	
31	Clean alarm	Condition: If cleaning cycles are performed too frequently, there may be a problem with the pump that requires the attention of an operator. In that case a specific alarm is generated. Only cleaning cycles that start following an external event (digital signal) or analog measurement are considered for this alarm.	
		Solution: Check the system.	
32	Not Used 6		
33	Min Speed	Condition: the drive is active and pump speed has been maintained at a speed lower than the setting for PAR 11004 Min Pump Speed for a time greater than the setting for PAR 11352 Min Speed AI TimeOut .	
		Solution: Check the system.	
34 ... 40	Plc2 fault ... Plc8 fault	Condition: Enabled application developed in the IEC 61131-3 environment has found the conditions for generating this specific alarm to be true. The meaning of the alarm depends on the type of application. For more information, refer to the documentation concerning the specific application..	
		XXXXH-X	The XXXXH-X code indicates the reason for the error: make a note of this to discuss it with the service centre.
		Solution: Refer to the documentation concerning the enabled application.	
52 53 54 55	Analog 1 Err Analog 2 Err Analog 3 Err Analog 4 Err	Condition: If an analog measurement is out of the allowed range an "Analog X err" alarm is generated. This control is only possible for 4-20 mA, PT100, PT1000, NI1000 probes. For temperature probes both short-circuits and power loss on the cable are detected. For 4-20 mA probes only power loss on the cable is detected. Analog 1 Err = Error on analog channel 1 Analog 2 Err = Error on analog channel 2 Analog 3 Err = Error on analog channel 1 of expansion card Analog 4 Err = Error on analog channel 2 of expansion card	
		Solution: Check connections.	

F – MESSAGES

Note ! For more information see Quick start guide, **chapter 6.7**.

Index	Error message shown on the display	Sub-code	Description
1	Load default param	Condition: may occur during loading of the parameter database saved in flash normally appears in the following conditions: at initial power-on when a new firmware version is downloaded, when the regulation is installed on a new size, when the region is changed. If this message is displayed when the drive is already operating, this means that a problem has occurred in the parameter database saved in Flash. If this message is displayed the drive restores the default database, i.e. the one downloaded.	
		0001H-1	The database saved is not valid
		0002H-2	The database saved is not compatible
		0003H-3	The database saved refers to a different size from the current size
		0004H-4	The database saved refers to a different region from the current region
		Solution: Set the parameters to the value required and perform Save parameter	
2 3 4	Option detect slot 1 Option detect slot 2 Option detect slot 3	Condition: at power-on, the drive recognizes the presence of an optional card in one of the three expansion slots. One of the three messages is shown on the display	
		0H-0	None
		0004H-4	Can/DeviceNet
		00FFH-255	Unknown
		0104H-260	Profibus
		0204H-516	Rte
		0301H-769	I_0_1
		0701H-1793	I_0_2
		0901H-2305	I_0_3
		0D01H-3329	I_0_4
		1601H-5633	I_0_6 (EXP-IO-SENS-100-ADV)
		1901H-6401	I_0_7 (EXP-IO-D5R8-ADV)
		1E01H-7681	I_0_8 (EXP-IO-SENS-1000-ADV)
		Solution:	
5	Autotune	Condition: this may occur during the Autotune procedure	
		0	No error
		1	The commands are not configured in Local mode.
			Solution: Execute the requested configuration
		2	The Commands local sel parameter has not been configured from the keypad
			Solution: Execute the requested configuration
		3	The motor plate data parameters have changed but the Take parameters command, PAR 2020, has not been executed
			Solution: Execute the Take parameters command.
		4	The motor is not connected
			Solution: Connect the motor
		5	While running self-tuning the ESC key was pressed or the enable contact was opened or an alarm occurred. The Autotune command was sent with the drive in the alarm condition
			Solution: Eliminate the reason for the alarm, remove the reason for the opening of the enable contact, reset alarms.
		6	A setting performed by the Autotune function produced a parameter value outside the min or max range.
Solution: Check the motor plate data or drive and motor sizes have been combined incorrectly.			
7	The Autotune command was sent without being enabled.		
	Solution: Close the enable contact before sending the Autotune command		
8 ... 21	A setting performed by Autotune has reached a measurement method limit		
	Solution: Check the motor plate data or the drive and motor sizes have been combined incorrectly.		

Index	Error message shown on the display	Sub-code	Description
			<p>Solution: If the message appears with a value other than 0, follow the instructions supplied for each particular case and repeat Autotune. This should be performed using the wizard function available from the keypad (STARTUP WIZARD) and the Tool software on the PC.</p> <p>Pay attention to all motor plate data parameters, especially:</p> <ul style="list-style-type: none"> - Rated speed, Motor rated speed in rpm. - Rated frequency, Motor rated frequency in Hz - Pole pairs, Motor pole pairs <p>Take care not to set the Rated speed parameter to the synchronous speed. The value of the Rated speed parameter must be less than: $[(\text{Rated frequency} * 60) / \text{Pole pairs}]$.</p> <p>If the problem persists even after following the instructions supplied, confirm the values of the motor plate data parameters, execute the Take parameters command but not Autotune.</p>
6	Power config		Condition: may occur during recognition of power cards. If this message is displayed, it is not possible to drive the motor.
		0020H-32	The power card is configured for a drive that is incompatible with the regulation card
		0021H-33	The configuration of the power card is not compatible with the regulation card
		0017H-23	The configuration required is not available on the power card
			Solution: Download the correct configuration on the power card
7	Save par failed		Condition: during transfer of the parameters from the drive to the memory of the keypad
		0H-0	Communication error
		0025H-37	The data saved on the keypad are not valid
		0026H-38	Incompatible drive series
		0027H-39	Incompatible software version
		0028H-40	Incompatible drive size
		0029H-41	Error during saving of parameters on the drive
	Solution:		
8 9	Load par failed Load par incomplete		Condition: during transfer of the parameters from the memory of the keypad to the drive
		0H-0	Communication error
		0025H-37	The data saved on the keypad are not valid. No parameter is transferred from the keypad to the drive
		0026H-38	Incompatible drive series. No parameter is transferred from the keypad to the drive
		0027H-39	Incompatible software version. All the parameters present in the memory of the keypad have been transferred to the drive. The set of parameters transferred refers to a drive with a different firmware version; therefore, certain parameters may not be updated.
		0028H-40	Incompatible drive size. All the parameters present in the memory of the keypad (excluding those that depend on the size of the drive), have been transferred to the drive. The parameters that depend on size maintain their original value.
		0029H-41	Error during saving of parameters on the drive. All the parameters present in the memory of the keypad have been transferred to the drive. The transfer of one or more parameters has caused an "out of range" error, or one or more parameters does not exist. At the end of transfer, one or more parameters may not have been updated.
		002AH-42	PLC application release and version not compatible. All parameters in the keypad memory have been transferred to the drive. The transferred set of parameters relates to a drive with a PLC application in which the version and release of the application are different. As a result some of the PLC application parameters may not be updated.
		002BH-43	PLC application not compatible. All the parameters in the keypad memory except those relating to the PLC application have been transferred to the drive. The transferred set of parameters relates to a drive with a different PLC application. As a result none of the PLC application parameters are updated.
			Solution: Recover a set of parameters from a compatible drive (model and size)
10	Options config error		Condition: may occur at drive start-up, during recognition of the optional cards installed
		0001H-1	Non-permissible optional card in slot 1
		0002H-2	Non-permissible optional card in slot 2
		0004H-4	Non-permissible optional card in slot 3
		0010H-16	Conflict slot 1 with slot 2
		0020H-32	Conflict slot 1 with slot 3
		0040H-64	Conflict slot 2 with slot 3

Index	Error message shown on the display	Sub-code	Description
			Solution: Remove the optional cards from the incorrect slots and insert them in the correct slots
11	Load def plc		Condition: may occur during loading of the parameter database saved in the Flash of the Mdplc application Normally appears at initial power-on after downloading a new application. If this message is displayed when the drive is already operating, this means that a problem has occurred in the parameter database saved in Flash. If this message appears the drive restores the default database, i.e. the one that was downloaded.
		0001H-1	The database saved is not valid
			Solution: Set the parameters to the value required and perform Save parameter
12	Plc cfg error		Condition: may occur during loading of the Mdplc application The Mdplc application present on the drive is not run.
		0004H-4	The application downloaded has a different Crc on DataBlock and Function table
		0065H-101	The application downloaded has an invalid identifier (Info)
		0066H-102	The application downloaded has an incorrect task number (Info)
		0067H-103	The application downloaded has an incorrect software configuration
		0068H-104	The application downloaded has a different Crc on DataBlock and Function table
		0069H-105	A Trap error or System error has occurred. The drive automatically performs a Power-up operation. The application is not run. See in Alarm List for further information regarding the error occurred
		006AH-106	The application downloaded has an incorrect identifier (Task)
		006BH-107	The application downloaded has an incorrect task number (Task)
		006CH-108	The application downloaded has an incorrect Crc (Tables + Code)
13	Plc 1		Reserved messages and dedicated to the PLC application. See the application manual.
14	Plc 2		
15	Plc 3		
16	Plc 4		
17	Option bus fault		Condition: this may occur when the drive is turned on, during fieldbus card setup. Error during configuration or communication error.
		XXX0H-X	If the first digit to the left of "H" in the alarm sub-code is 0, the error regards a communication problem.
		XXX0H-X	If the first digit to the left of "H" in the alarm sub-code is other than 0, the error regards a configuration problem.
			Solution: For configuration errors, check the configuration of the bus communication, type of bus, baudrate, address, parameter setting. For communication errors, check wiring, termination resistors, disturbance immunity, timeout settings. For further details, please refer to the user guide for the specific bus.
18	Key failed		Condition: this may occur when powering the drive, if the incorrect enable key is inserted for a given firmware function.
		0001H-1	Incorrect PLC key. PLC application not available.
			Solution: Ask WEG to supply the correct key to enable the desired firmware function.
19	Key expiring		Condition: this may occur at drive power-on if the incorrect enabling key was inserted for a given firmware function. At this stage the firmware function can still be used freely, but this time limit is about to expire.
		xxxxH-x	Number of hours for which the function can still be used freely.
			Solution: Ask WEG for the correct key to enable the desired firmware function.
20	Param error		Condition: if an error occurs during activation of the parameter database saved in flash; the alarm is inserted in the alarm list and alarm log.
		XXX0H-X	The code XXXXH-X indicates the IPA of the parameter that has been set outside the range allowed when the database is enabled.
			Solution: Set the parameter causing the error to a value within the range and run Save parameters . Switch the drive off and then switch it back on again. If the IPA of the parameter is not shown in the manual, contact the service centre.
21			
22	Options cfg changed		Condition: this may occur when powering the drive if an expansion card has been removed or replaced or the incorrect enable key is inserted for a given firmware function.
		0064H-100	Card removed from slot 1
		0014H-20	Card removed from slot 2
		0003H-3	Card removed from slot 3
		0078H-120	Card removed from slot 1 and from slot 2

Index	Error message shown on the display	Sub-code	Description
		0067H-103	Card removed from slot 1 and from slot 3
		0017H-23	Card removed from slot 2 and from slot 3
		007BH-123	Card removed from slot 1, from slot 2 and from slot 3
		Solution: Check the hardware configuration, then press ESC. Save the parameters (Save parameters , menu 04.1 par 550) to save the new hardware configuration.	

Note!

For any messages that are displayed but not included in this list reference should be made to the manual for the application used by the drive.

System Diagrams Index

DRIVE OVERVIEW	DrvOverview	DigInps	DIGITAL INPUTS
REFERENCES	References	DigOuts	DIGITAL OUTPUTS
RAMPS	Ramps	AnalInps	ANALOG INPUTS
MULTI REFERENCE	MultiRef	AnalOuts	ANALOG OUTPUTS
MOTORPOTENTIOMETER	Mpot	SpeedRegGains	SPEED REG GAINS
JOG FUNCTION	Jog	VFParameters	VF PARAMETERS
MONITOR FUNCTION	MonitorFunc	Functions	FUNCTIONS
COMMANDS	Commands	Process	PROCESS
		SolarPump	SOLAR PUMP

Drive overview

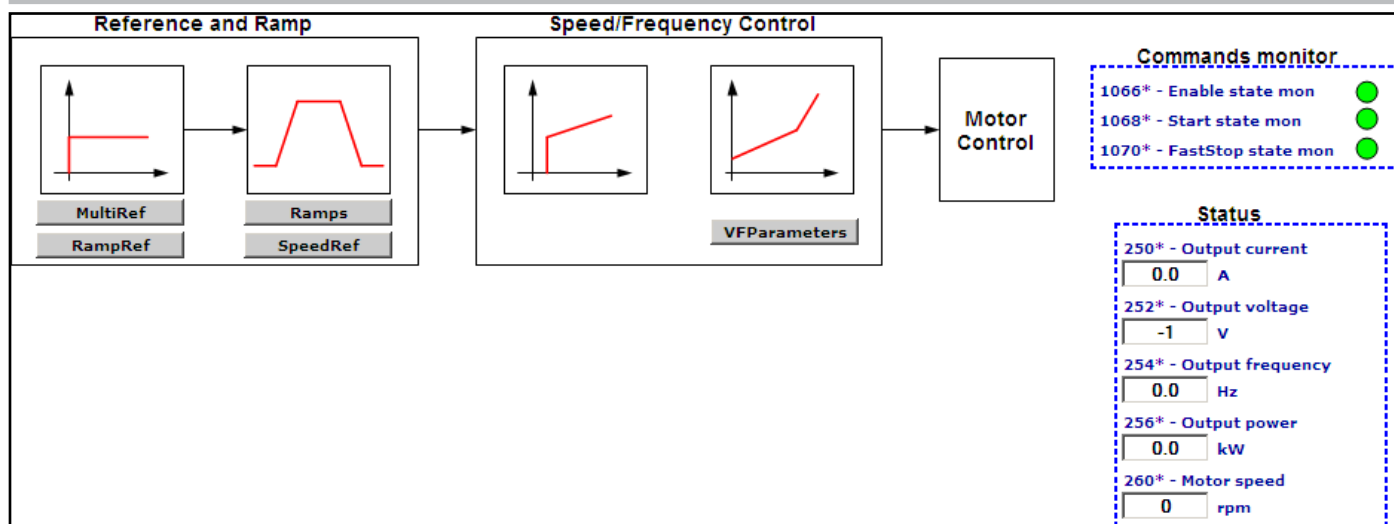

References

RAMP REFERENCE **RampRef**

SPEED REFERENCE **SpeedRef**

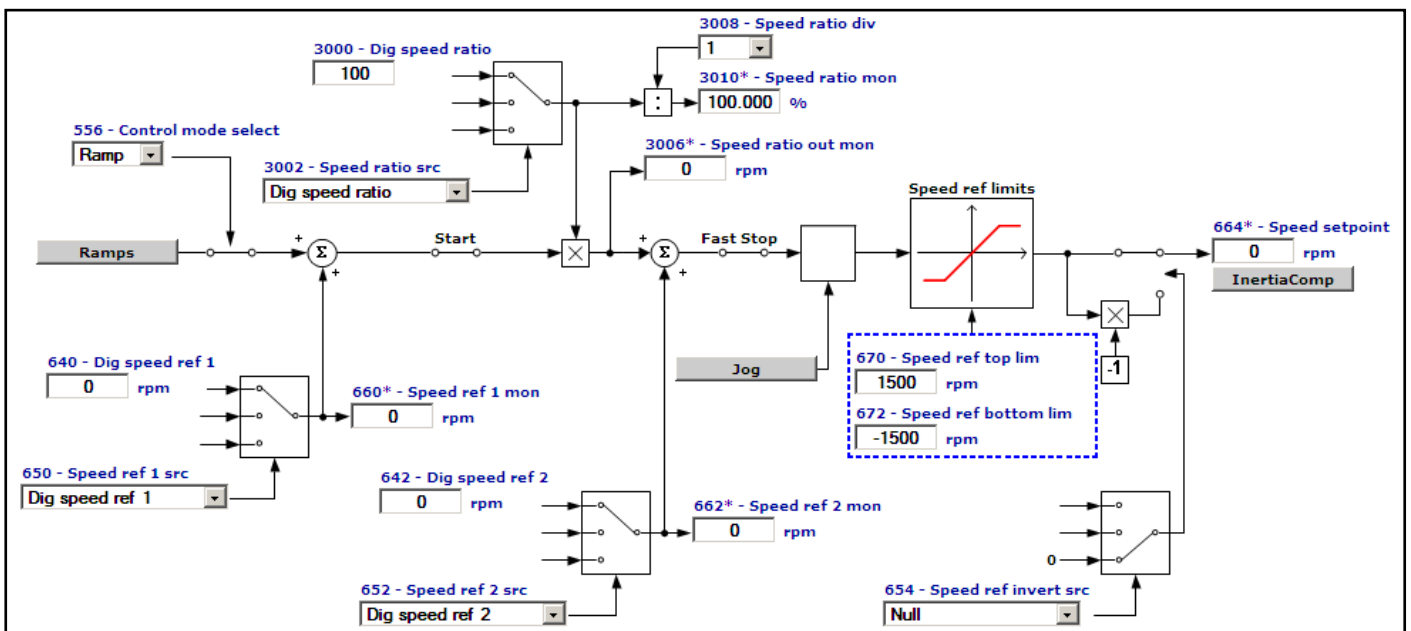
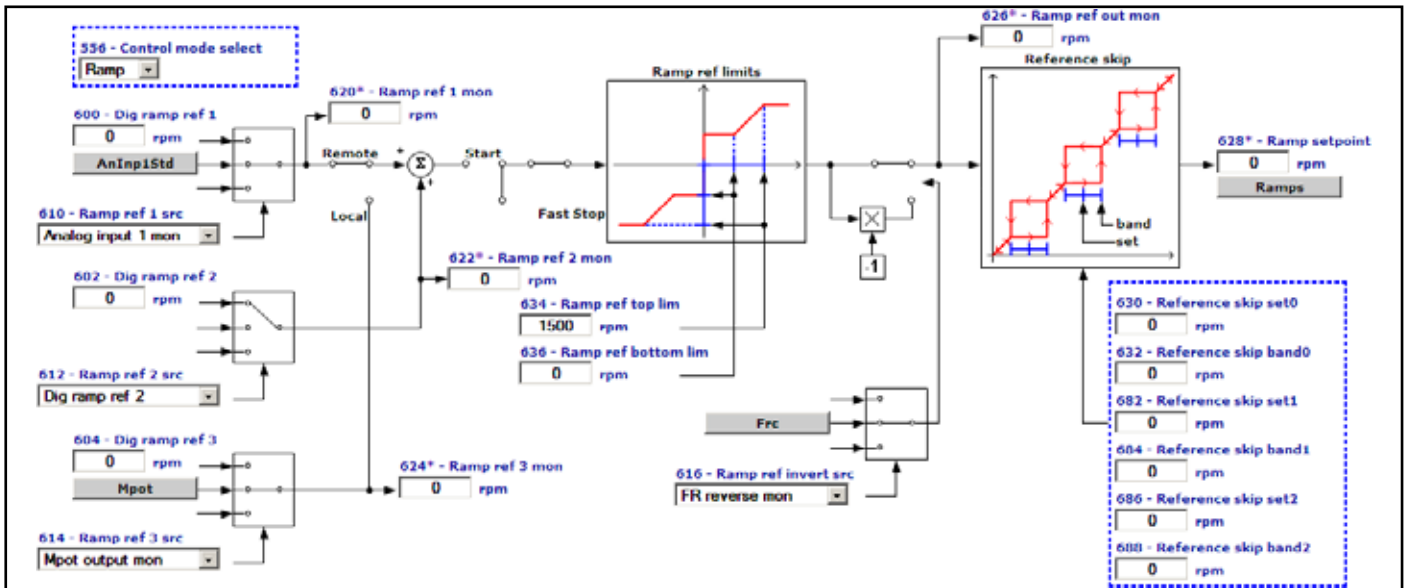

Ramps

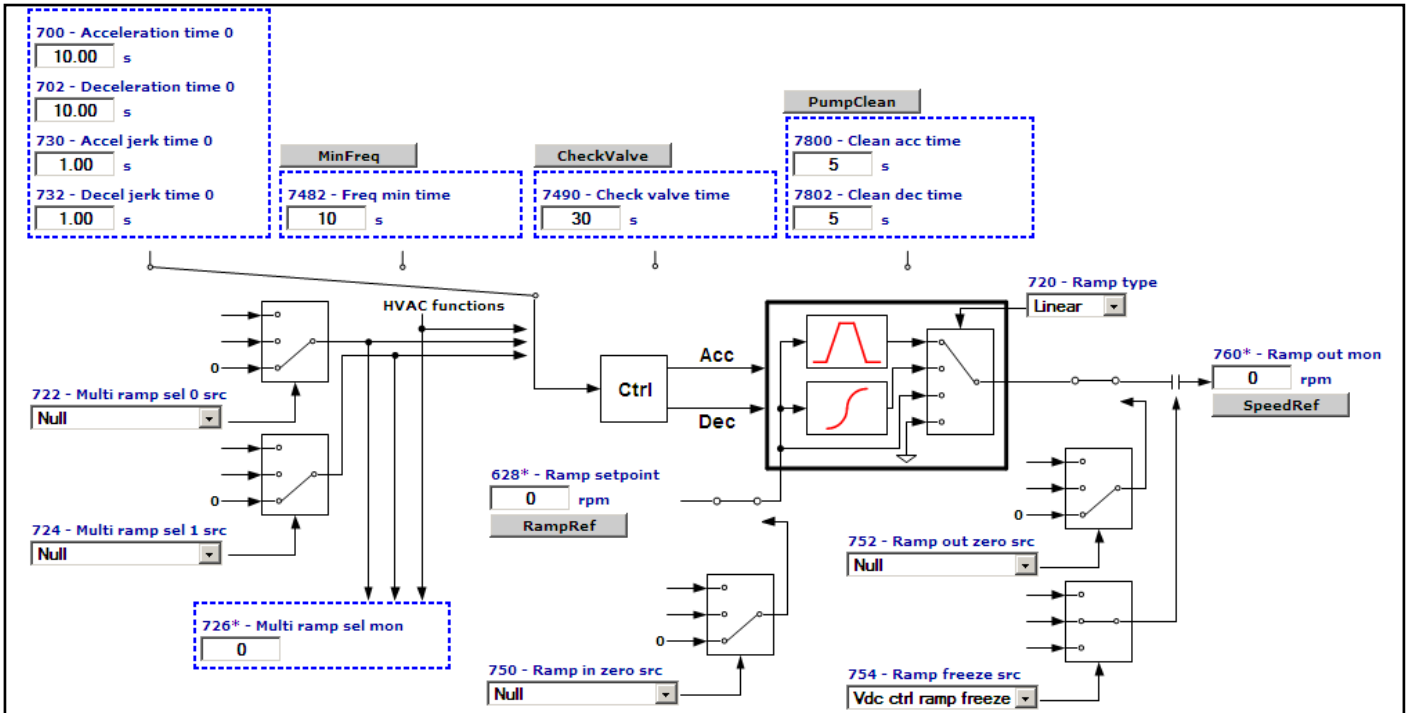

Multireference

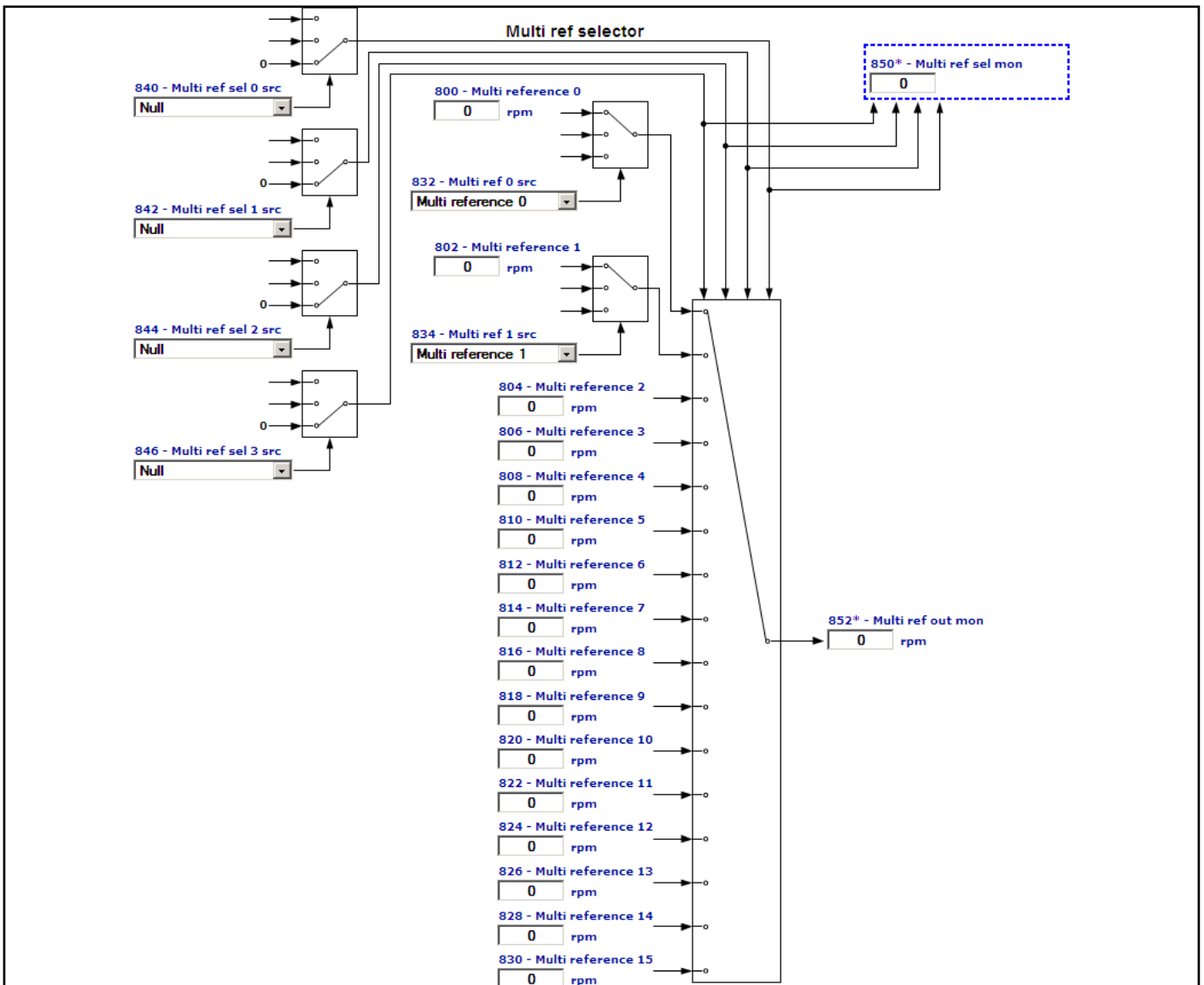

Motorpotentiometer

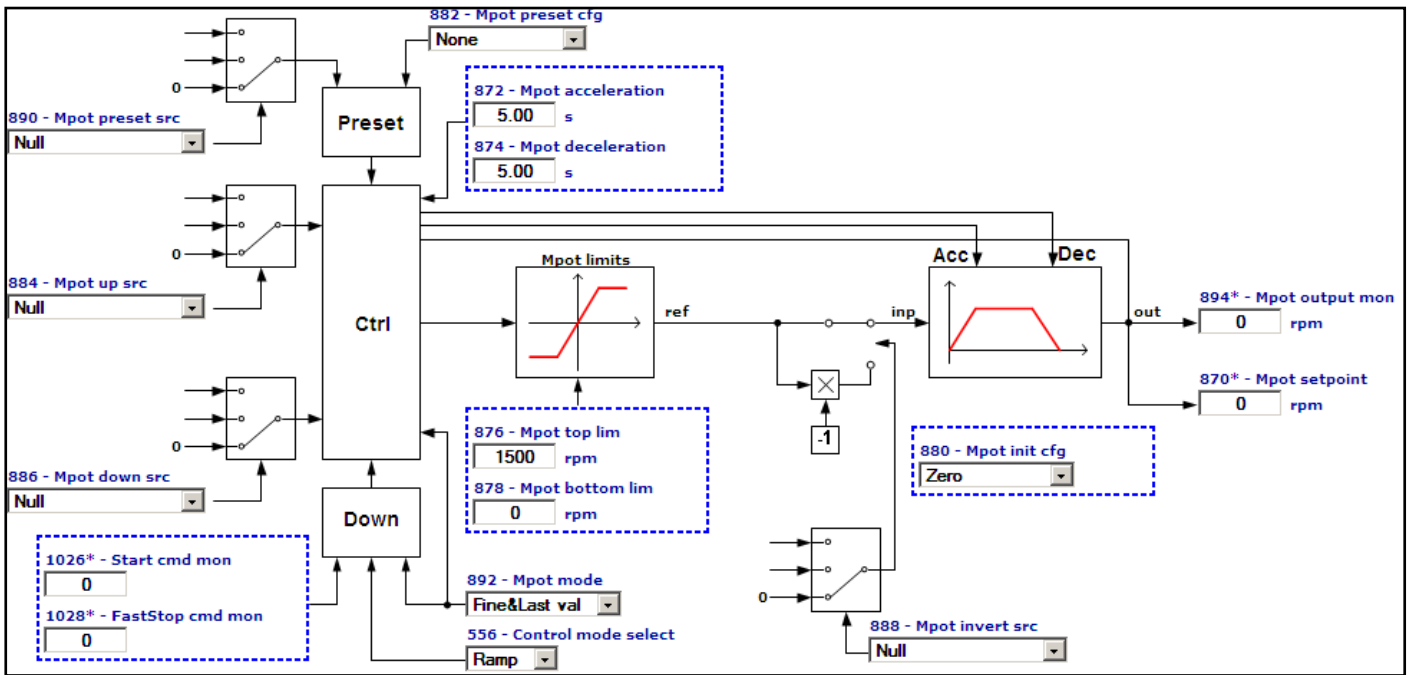

Jog function

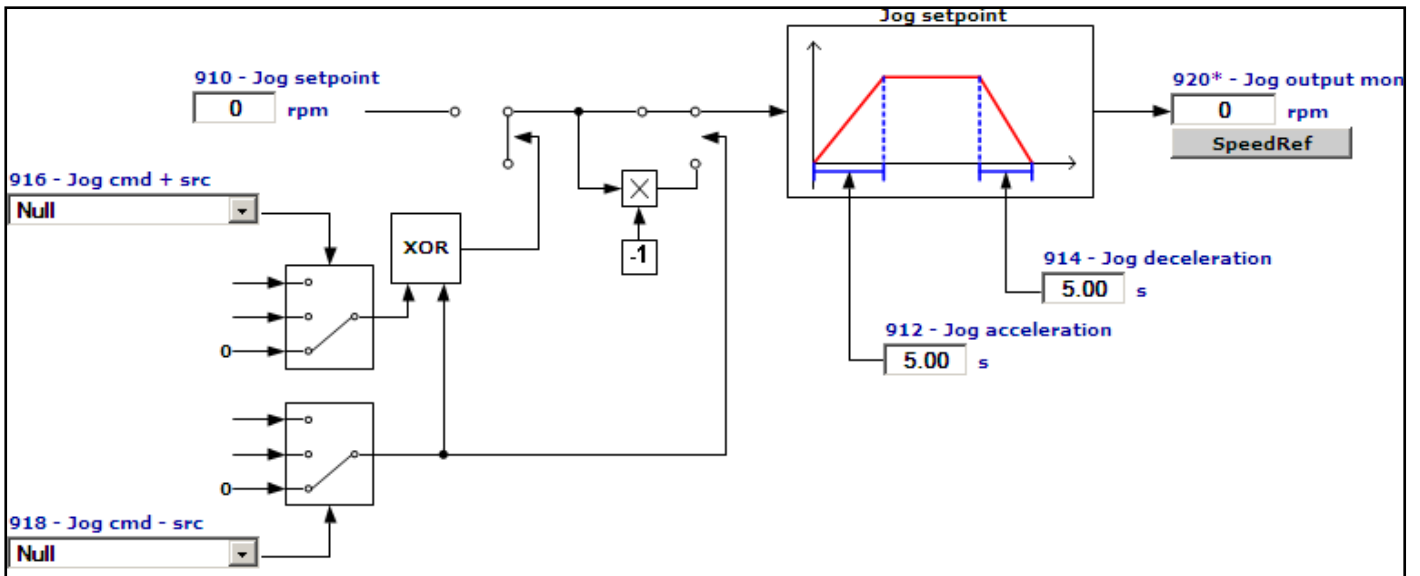

Monitor function

SPEED/REFERENCE ZERO	SpeedRefZero
SPEED THRESHOLD 1-2	SpeedThr1_2
SPEED THRESHOLD 3	SpeedThr3
SET SPEED	SetSpeed
CURRENT THRESHOLD	CurrThr

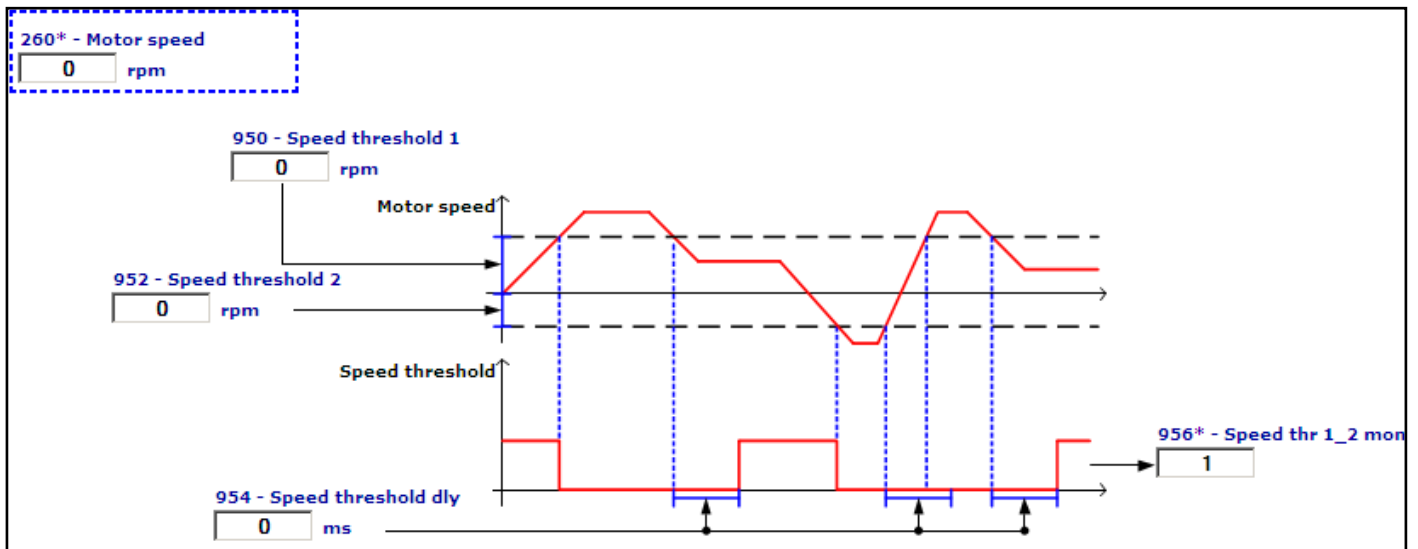
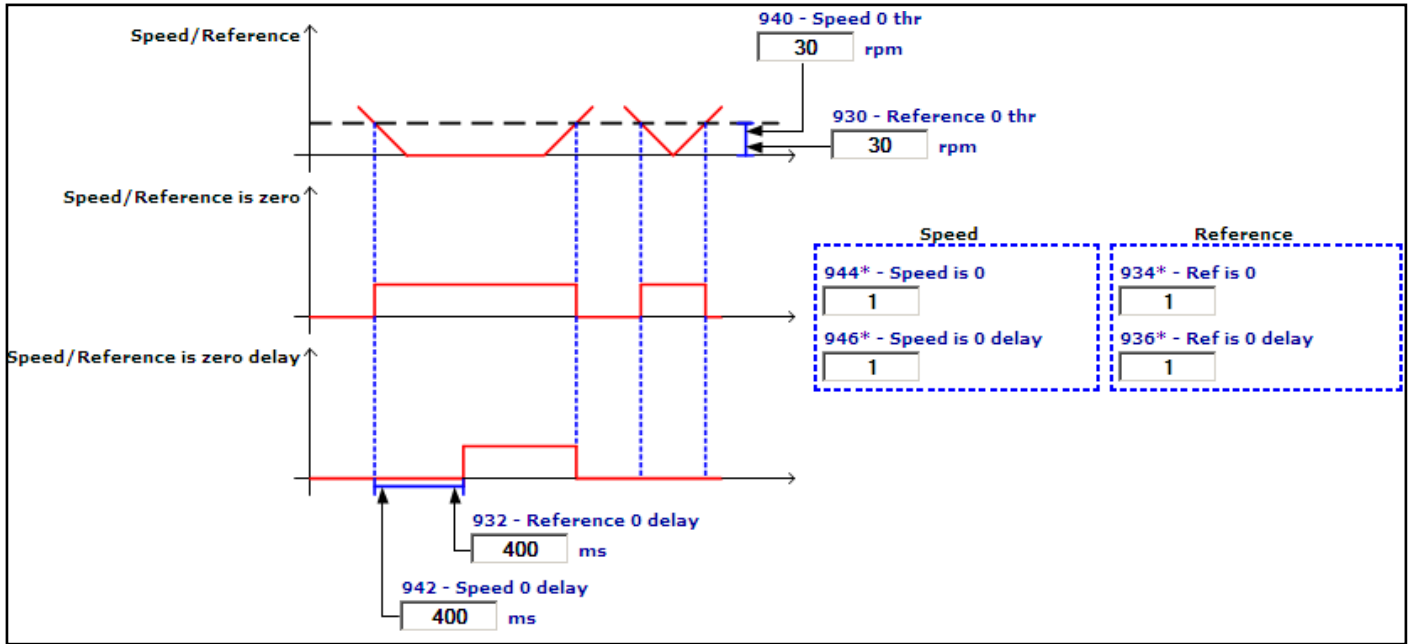

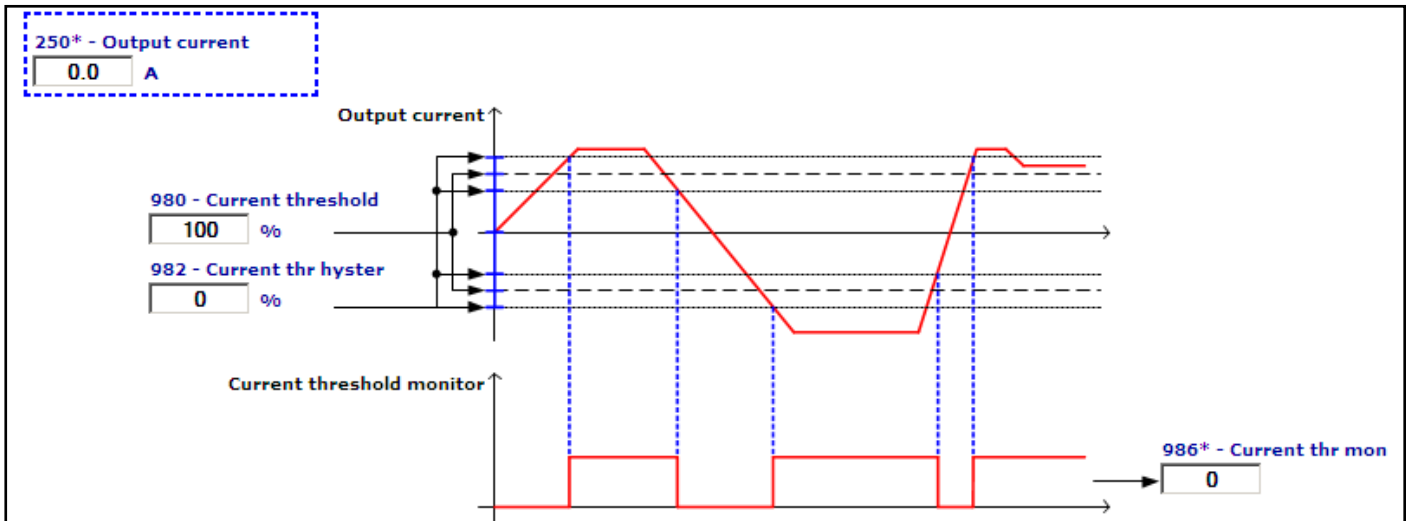
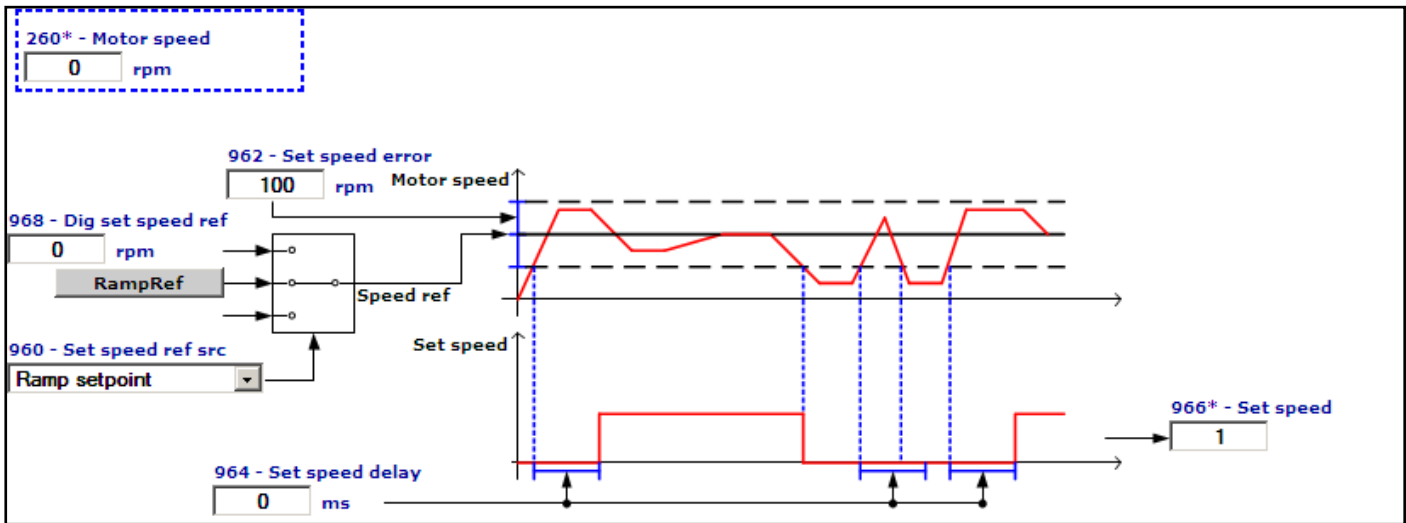
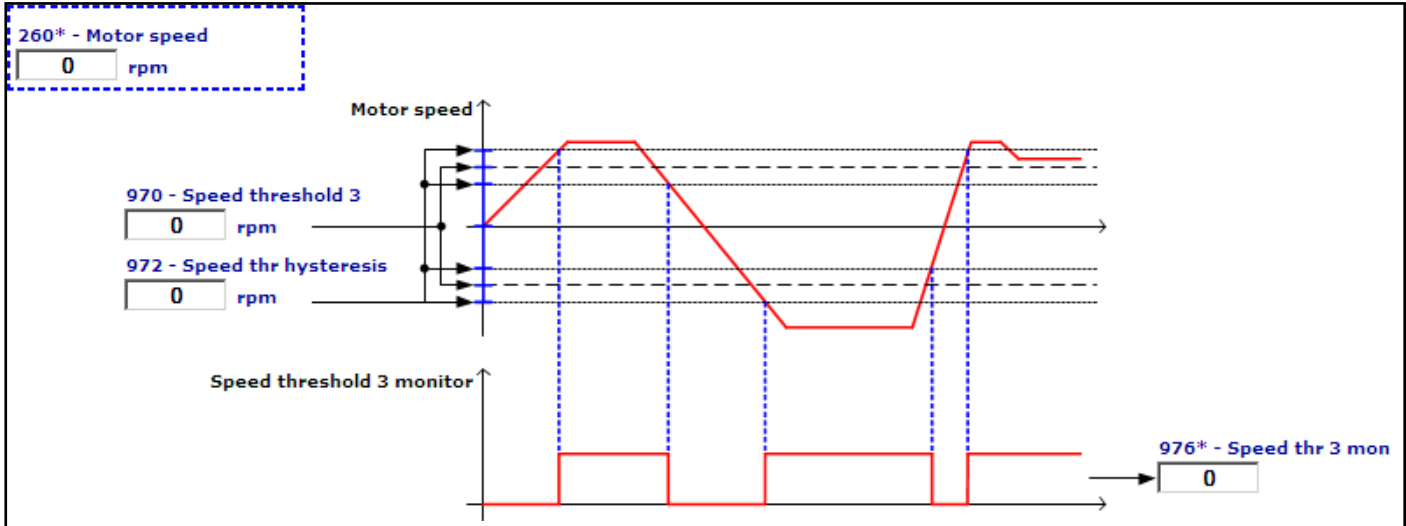

Commands

COMMANDS MANAGEMENT **CommManage**

FORWARD REVERSE CONTROL **Frc**

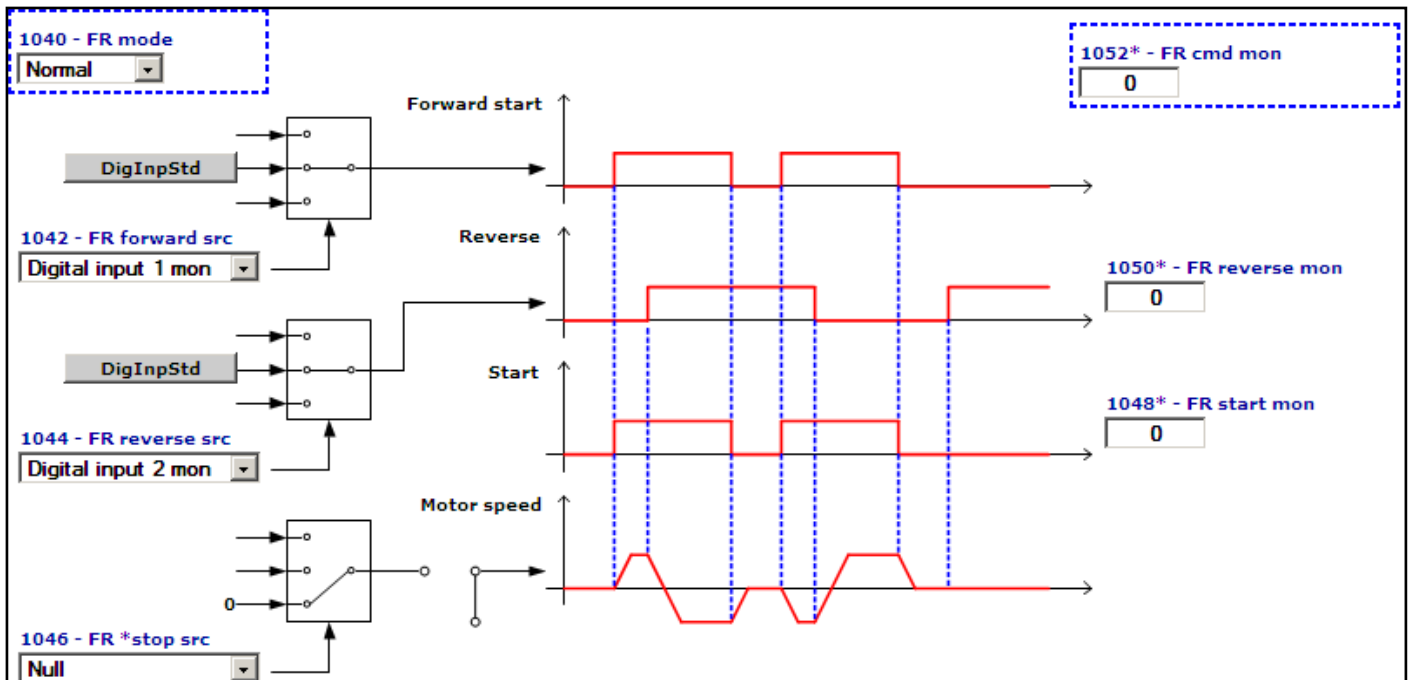
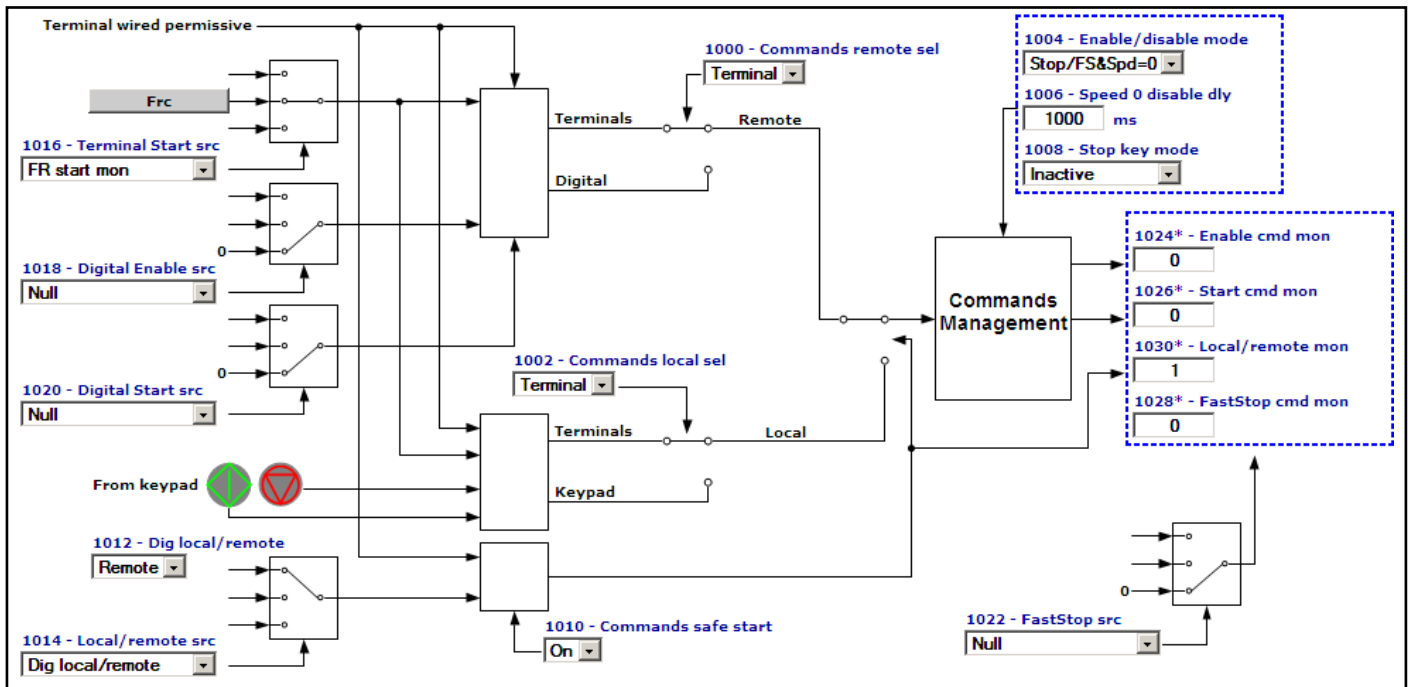

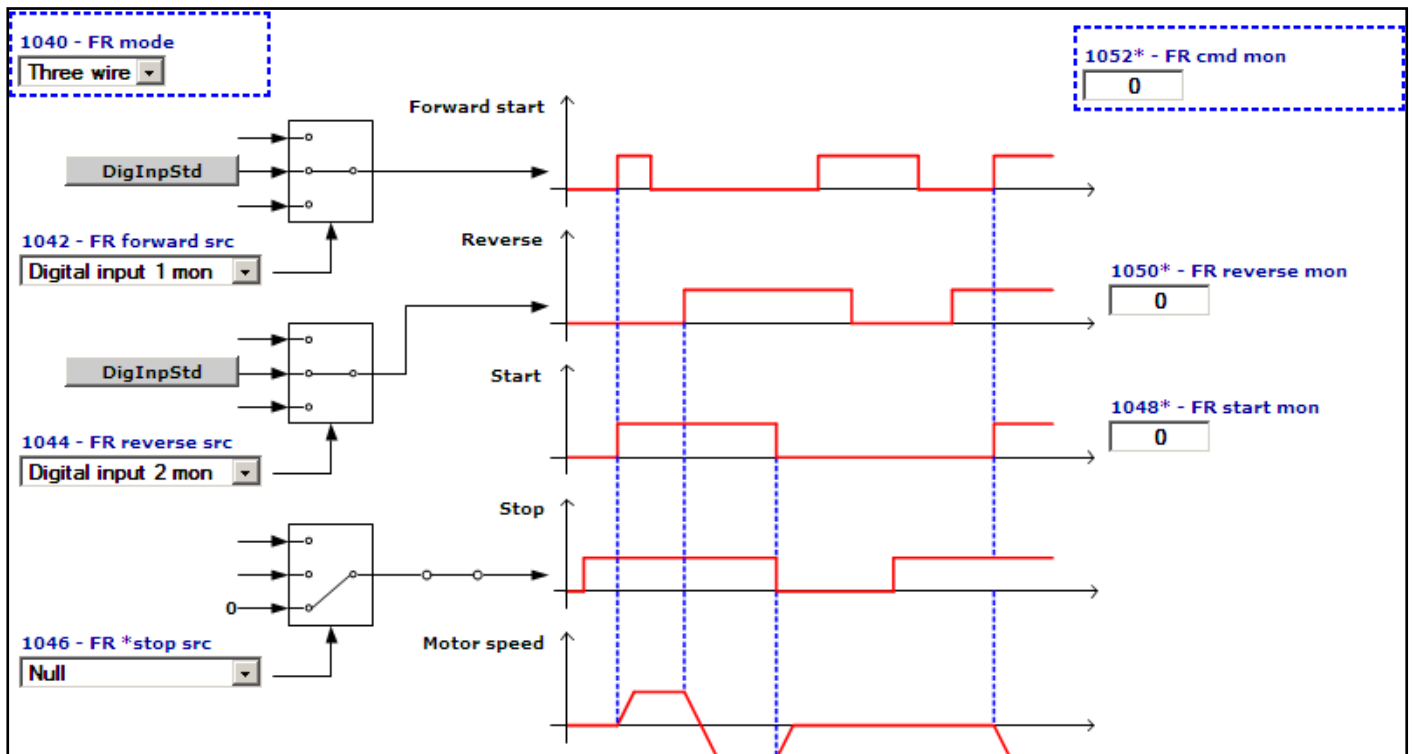
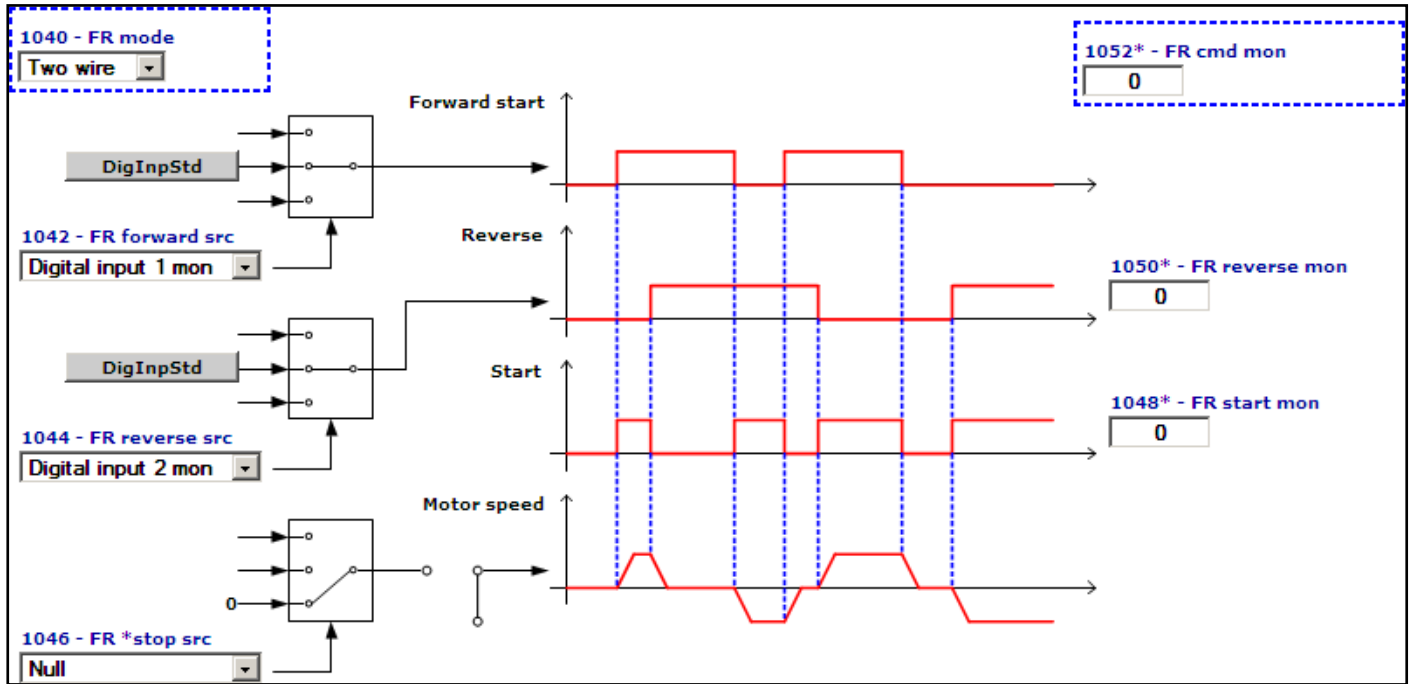

Digital inputs

DIGITAL INPUTS STANDARD

DigInpStd

DIGITAL INPUTS EXPANSION CARD

DigInpExp

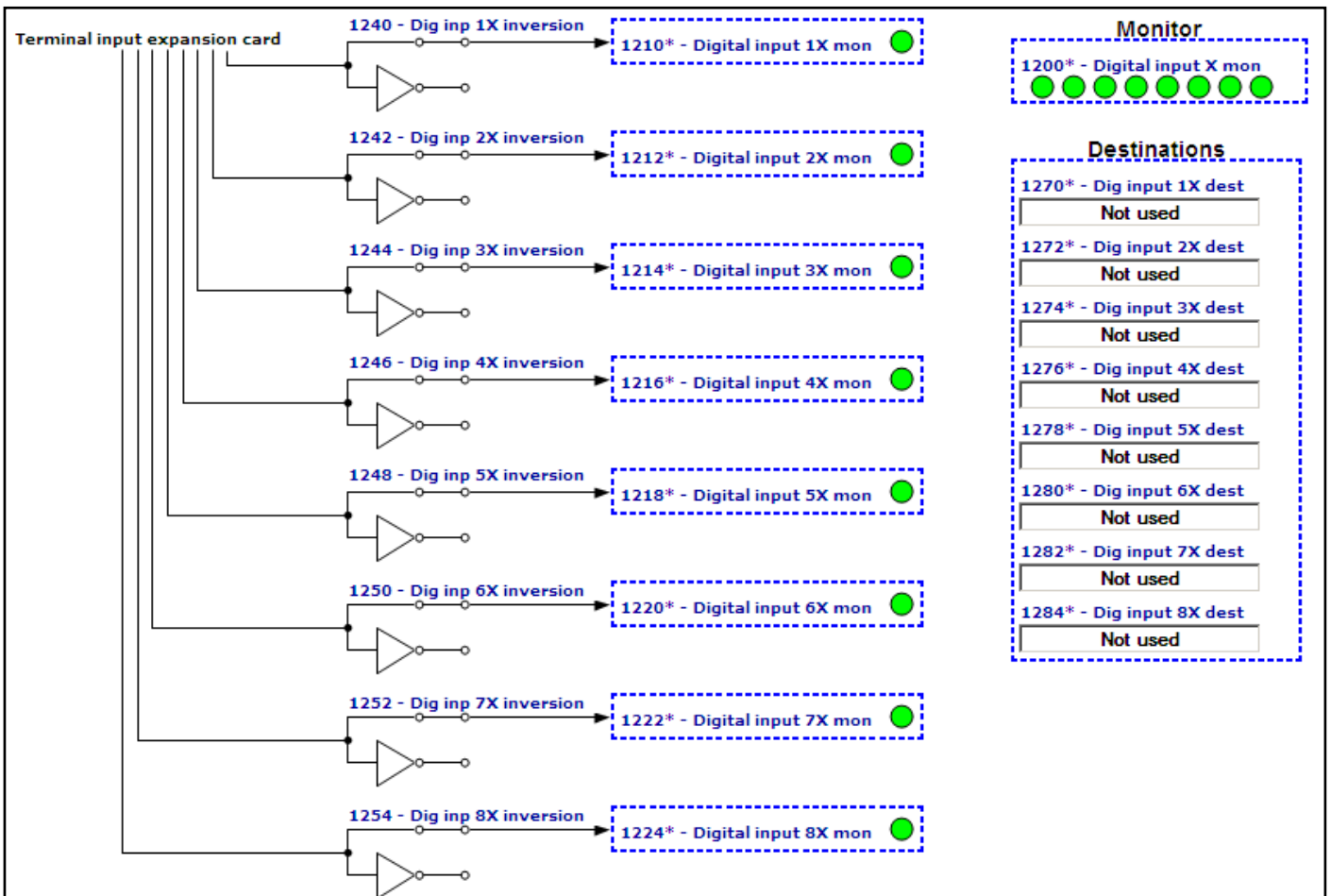
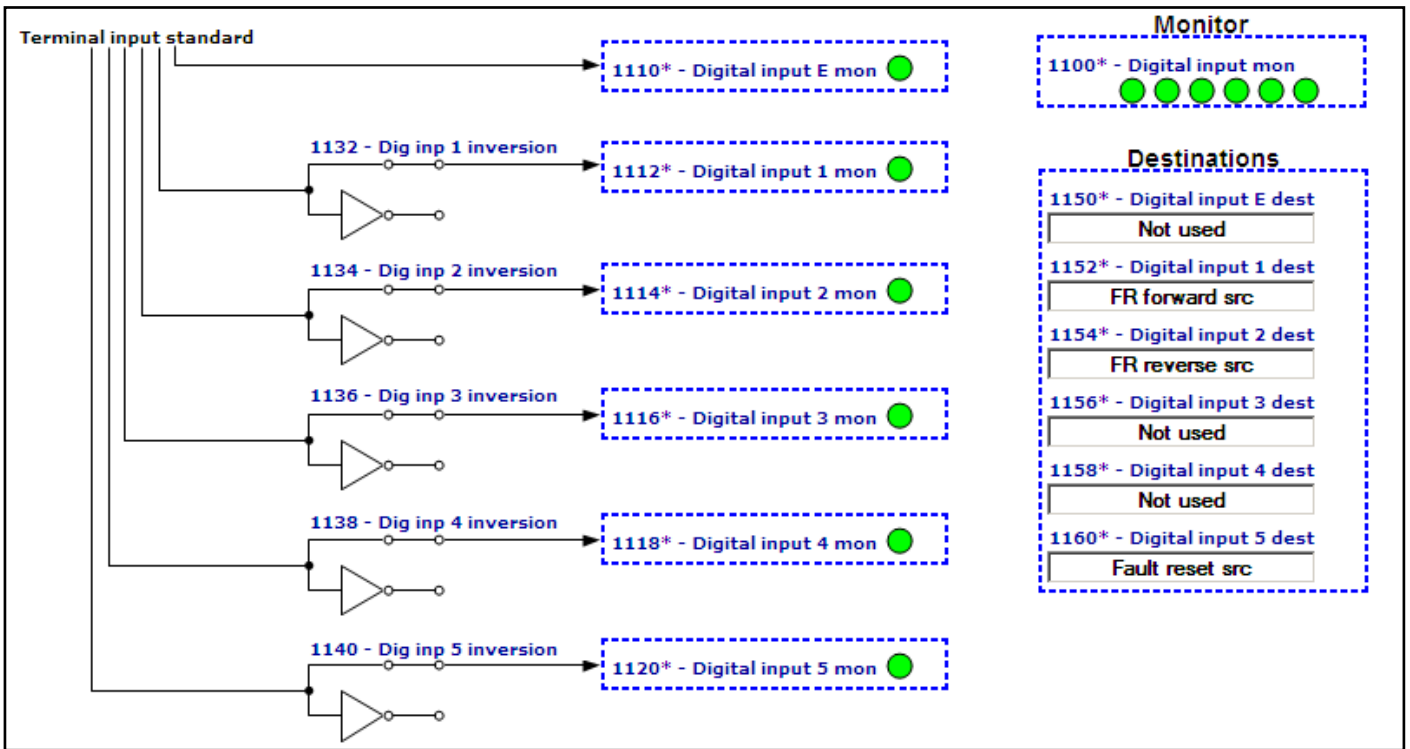

Digital outputs

DIGITAL OUTPUTS STANDARD

DigOutStd

DIGITAL OUTPUTS EXPANSION CARD

DigOutExp

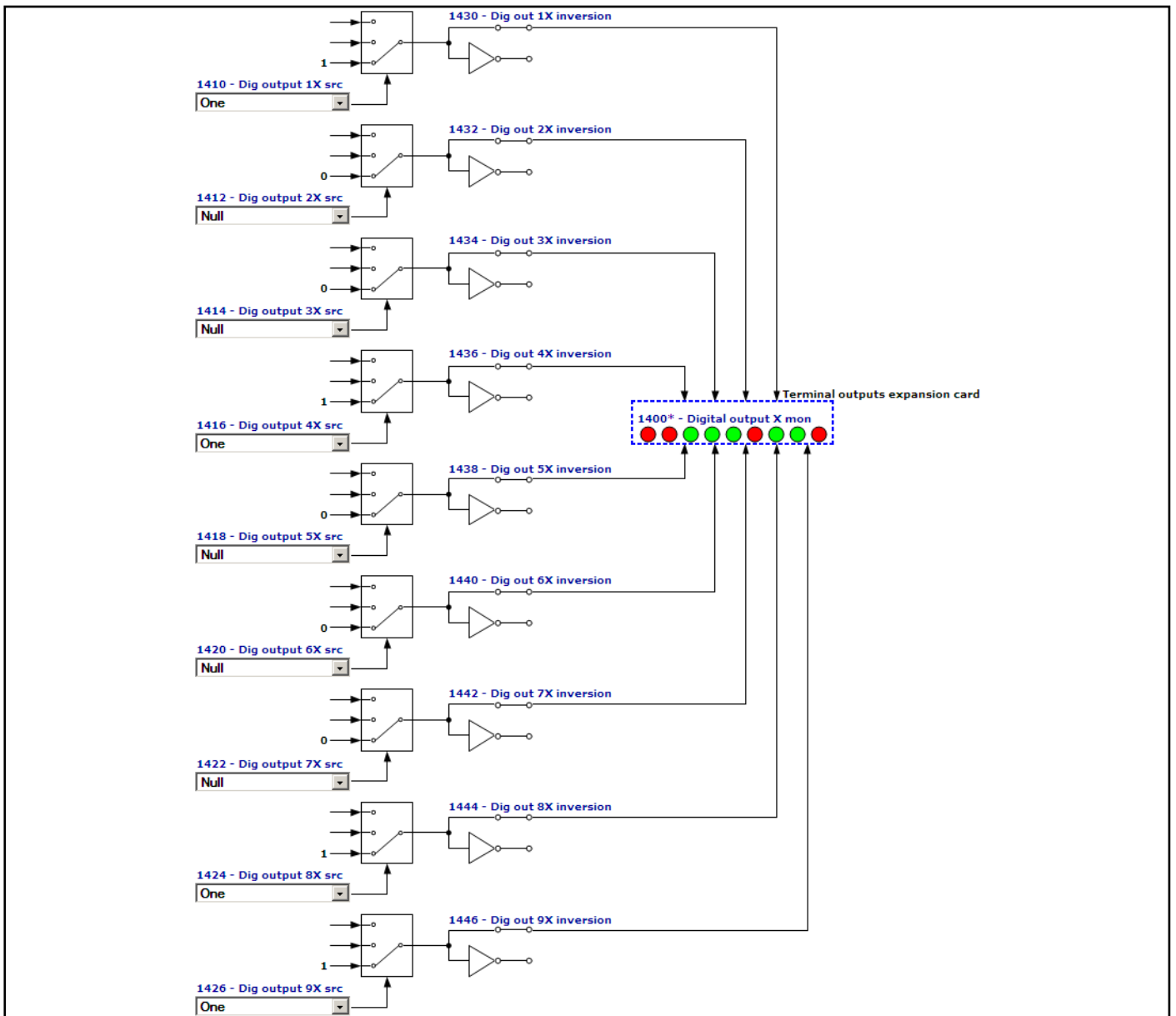
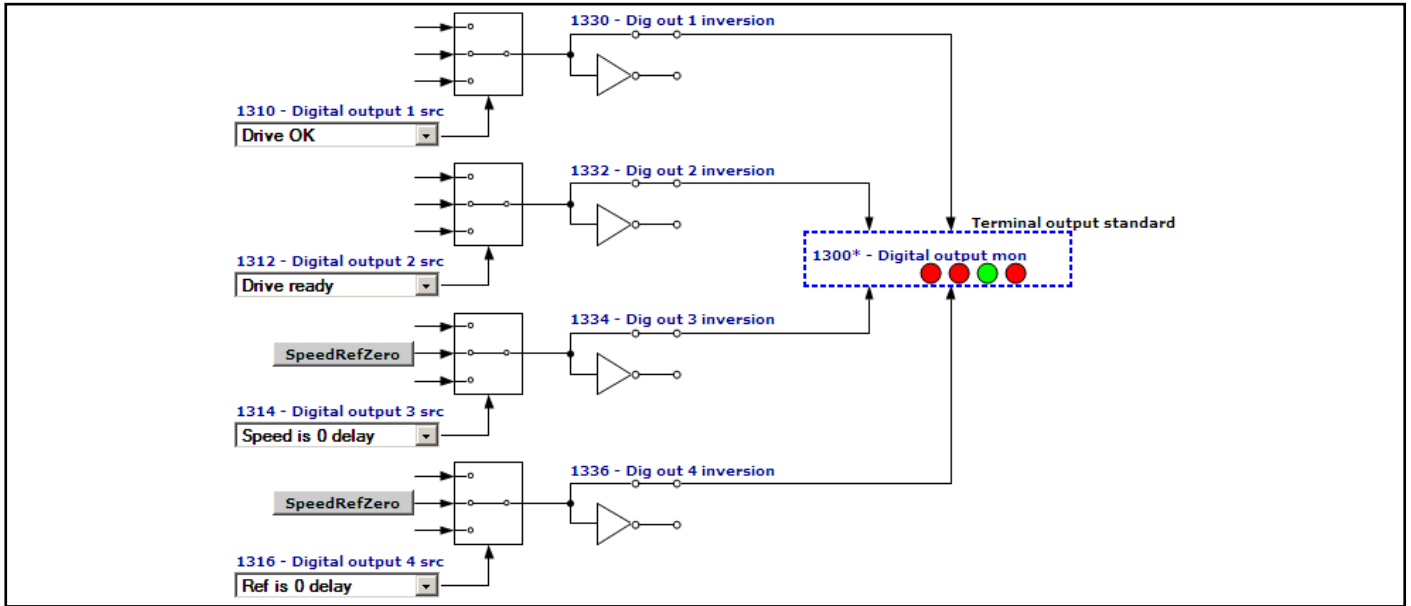

Analog inputs

ANALOG INPUT 1 STANDARD **AnInp1Std**

ANALOG INPUT 2 STANDARD **AnInp2Std**

ANALOG INPUT 1 EXPANSION CARD **AnInp1Exp**

ANALOG INPUT 2 EXPANSION CARD **AnInp2Exp**

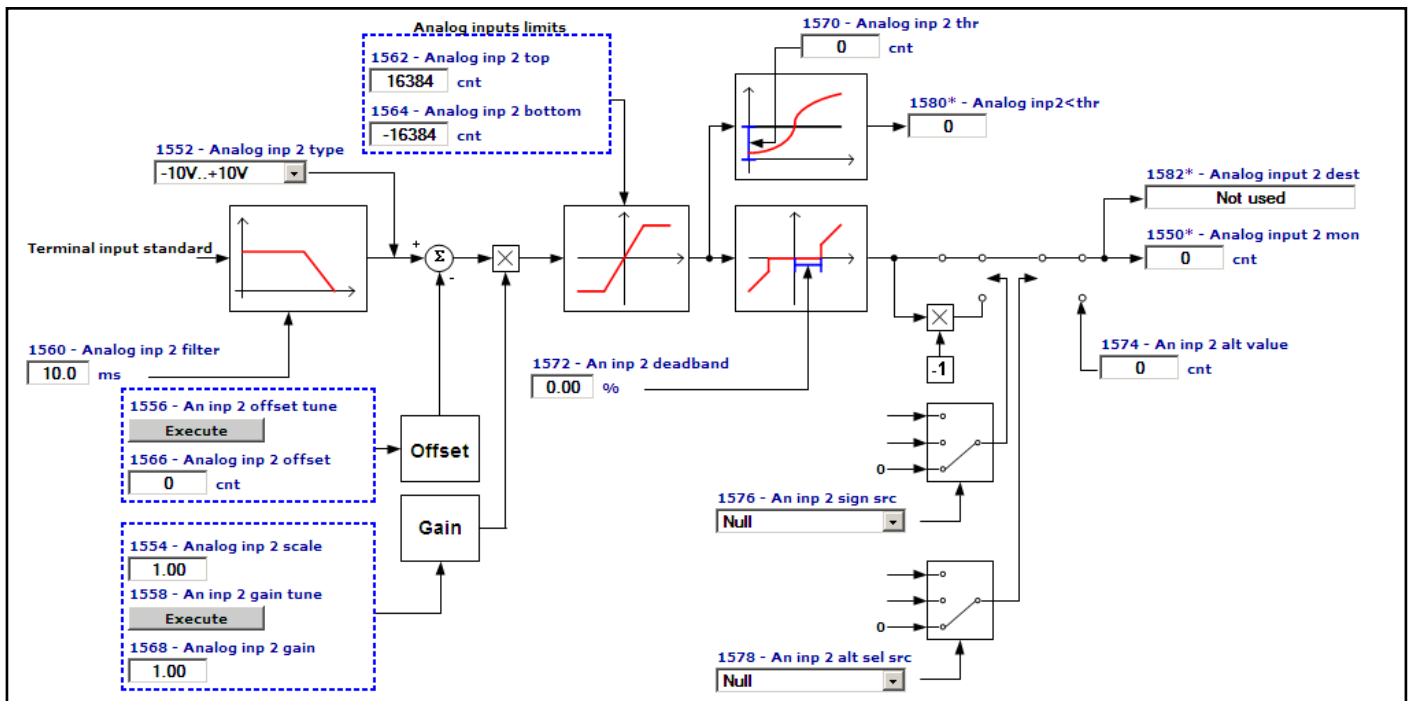
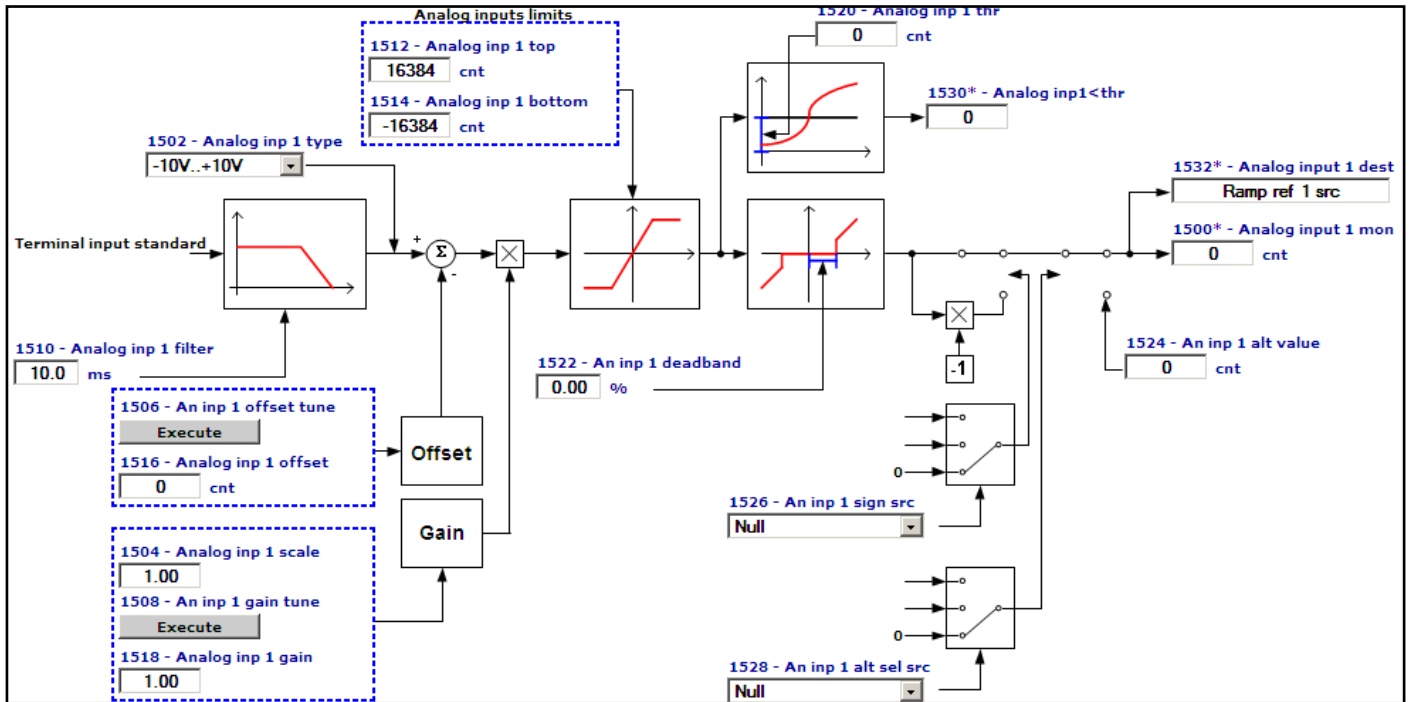

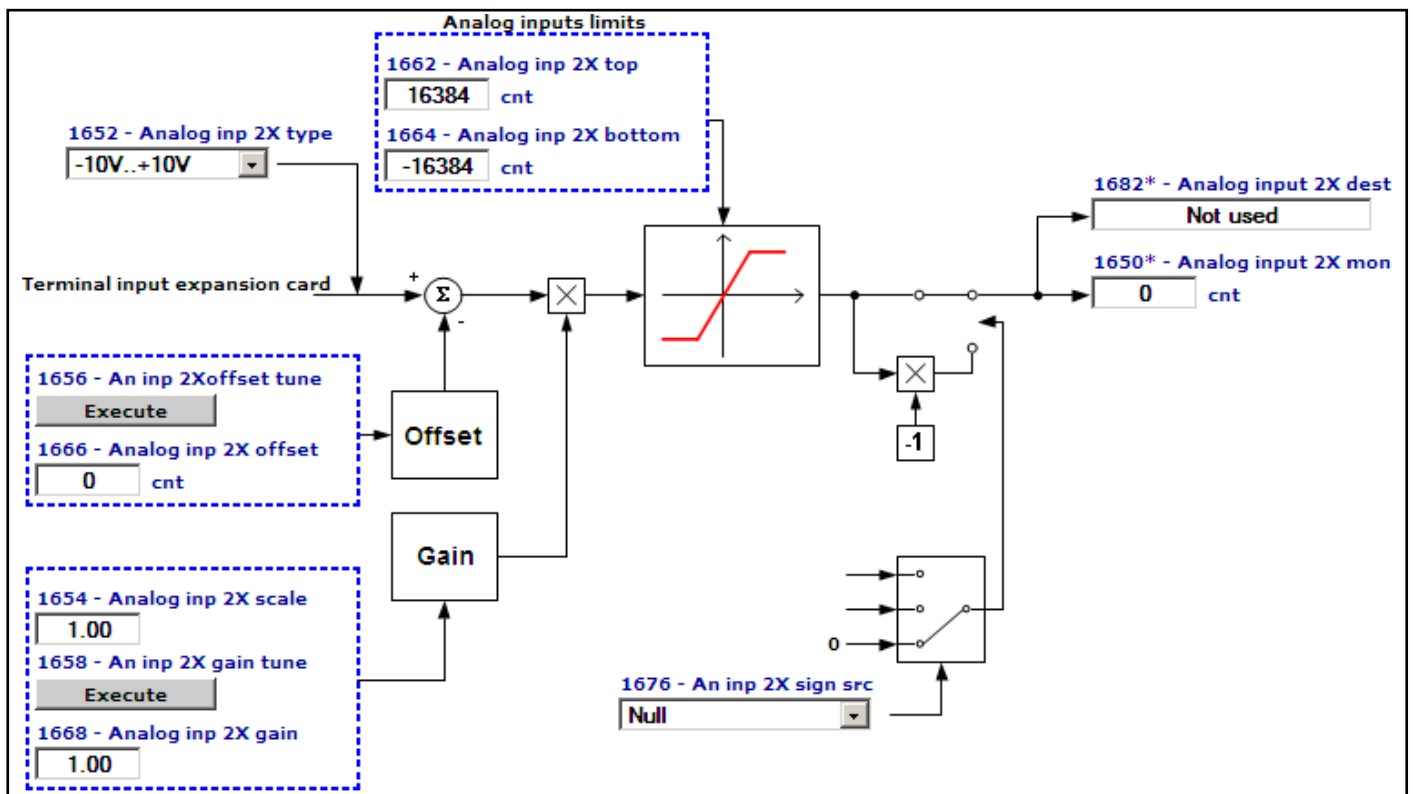
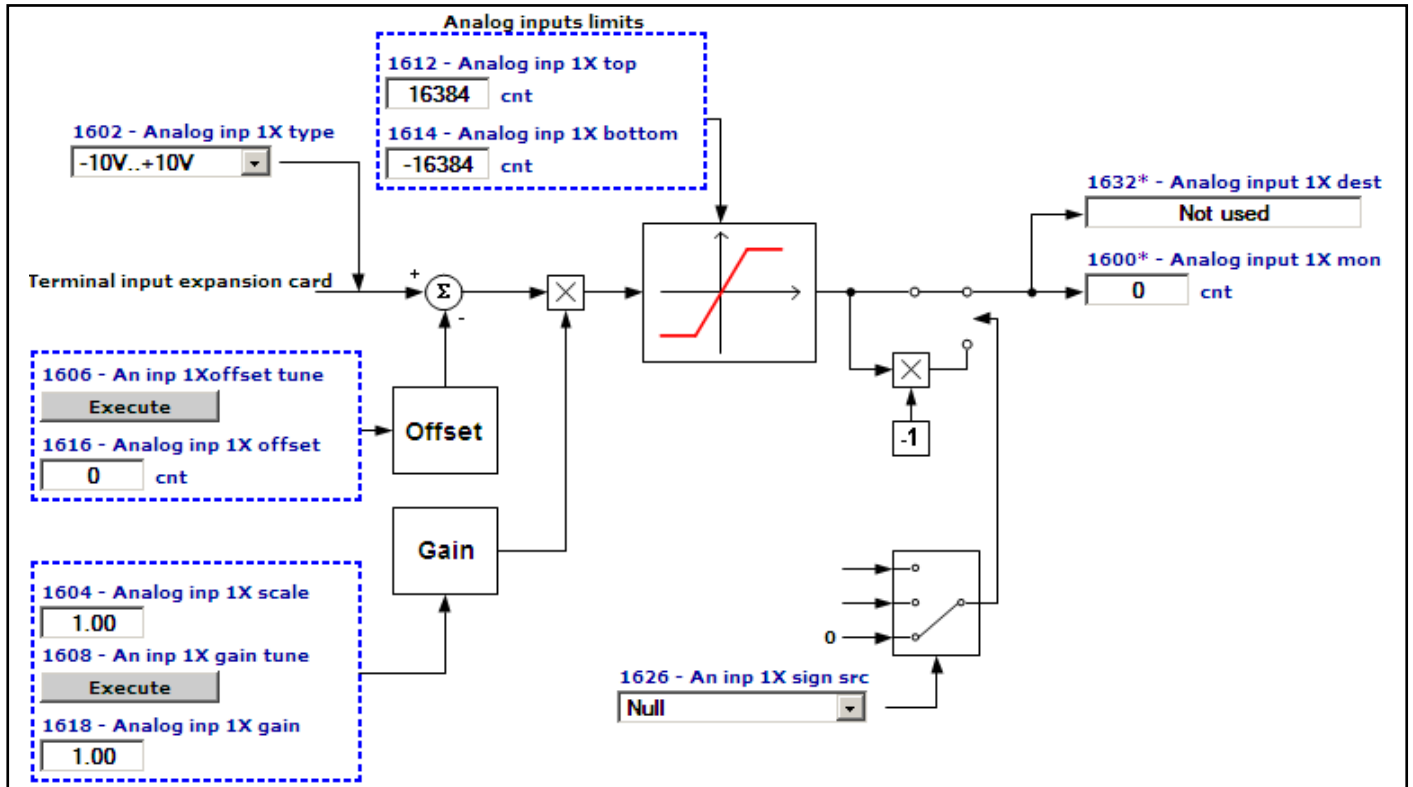

Analog outputs

ANALOG OUTPUT 1 STANDARD

AnOut1Std

ANALOG OUTPUT 2 STANDARD

AnOut2Std

ANALOG OUTPUT 1 EXPANSION CARD

AnOut1Exp

ANALOG OUTPUT 2 EXPANSION CARD

AnOut2Exp

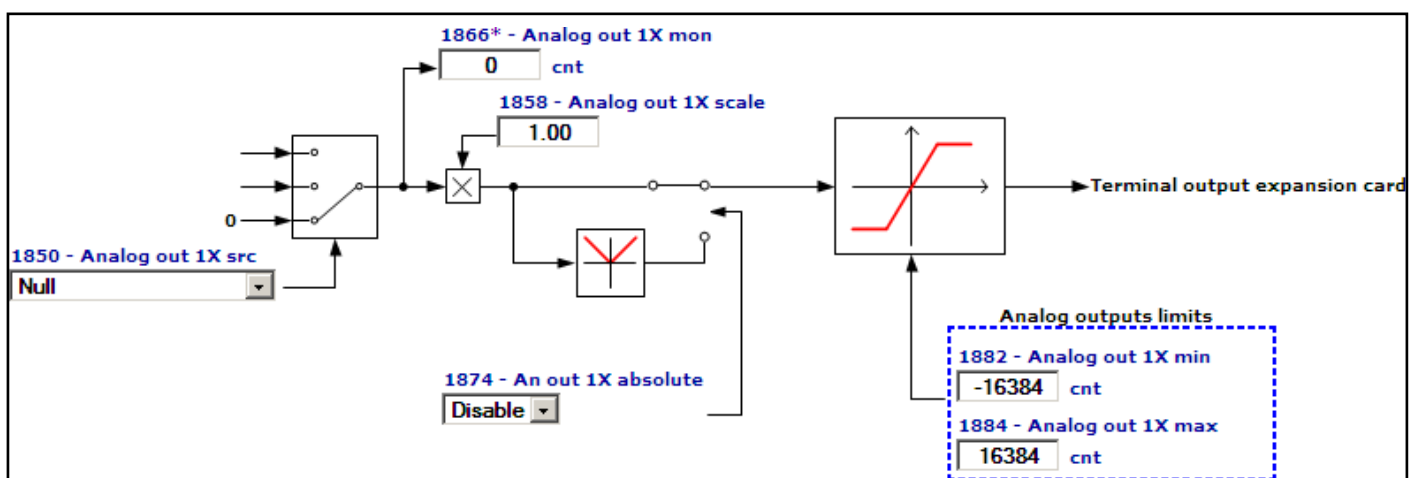
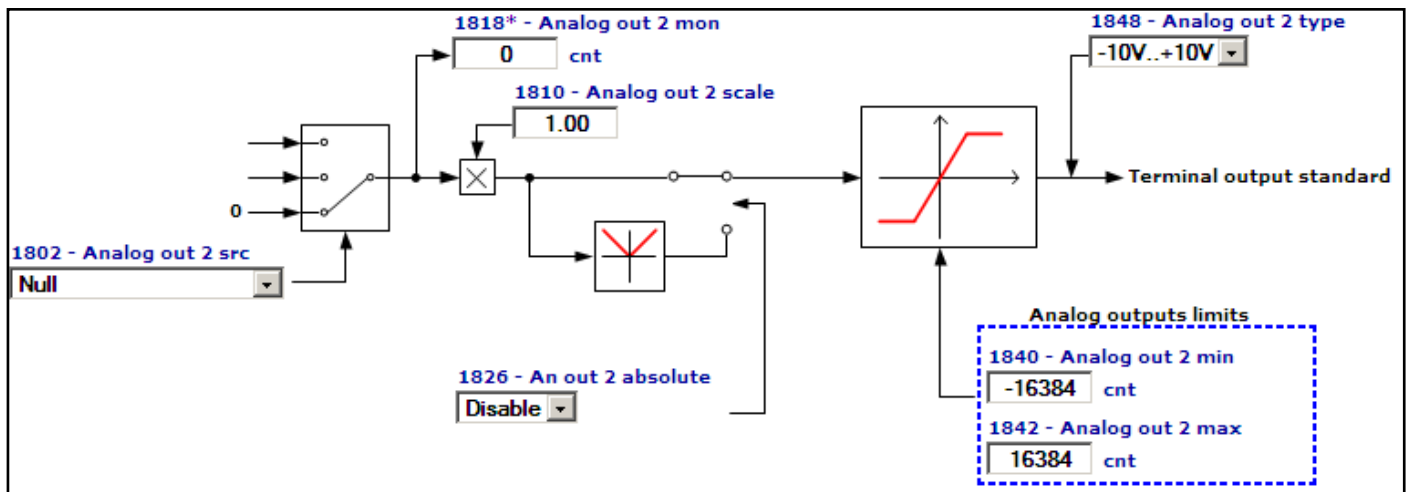
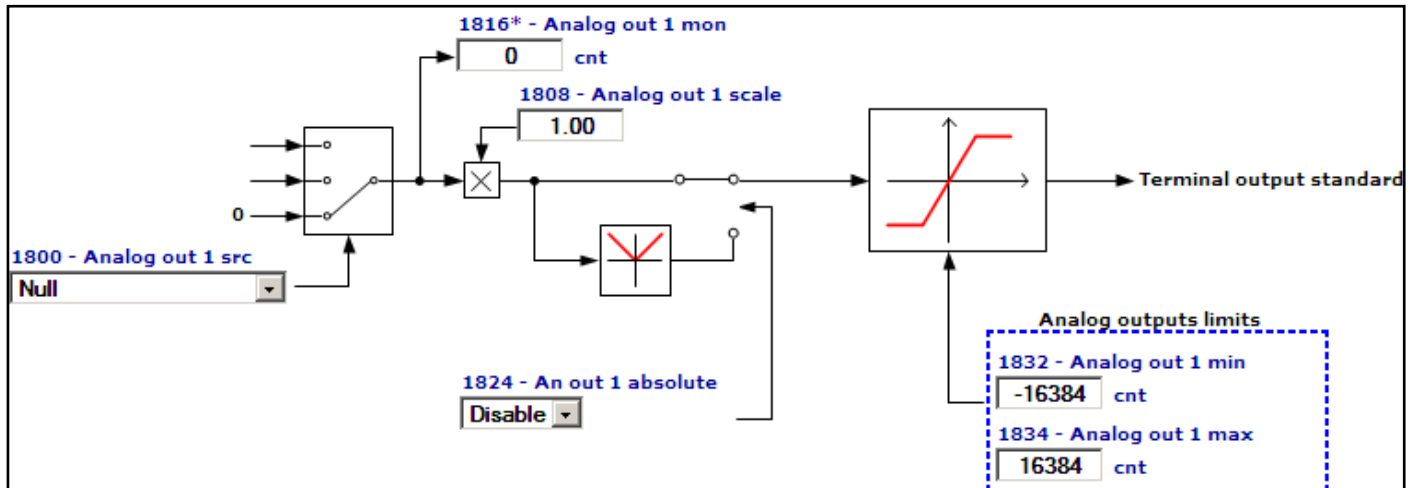

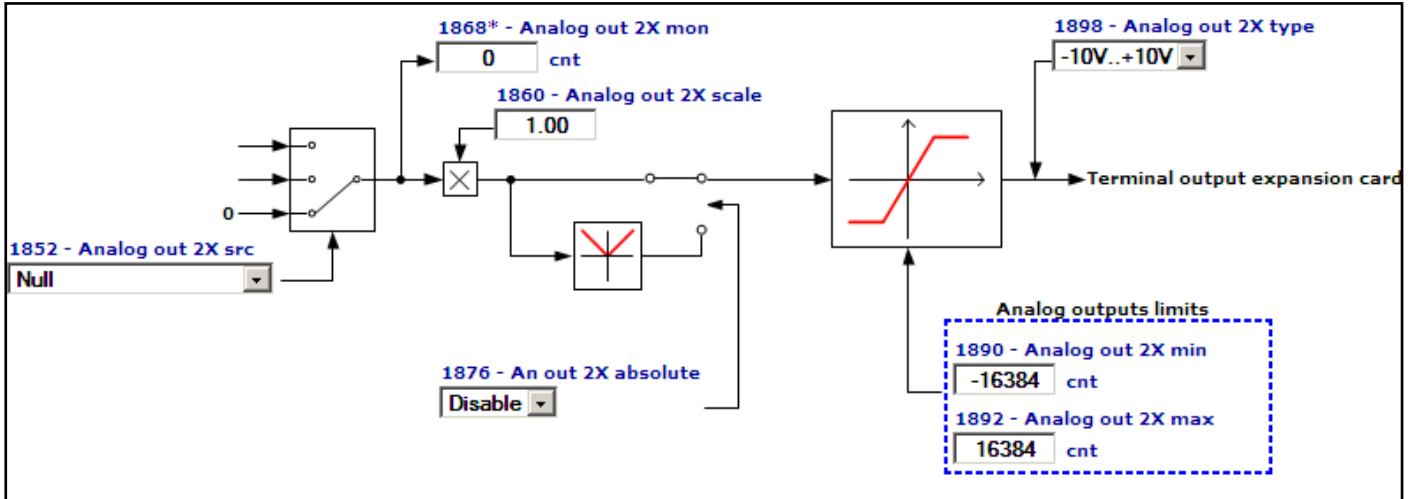

Speed reg gains

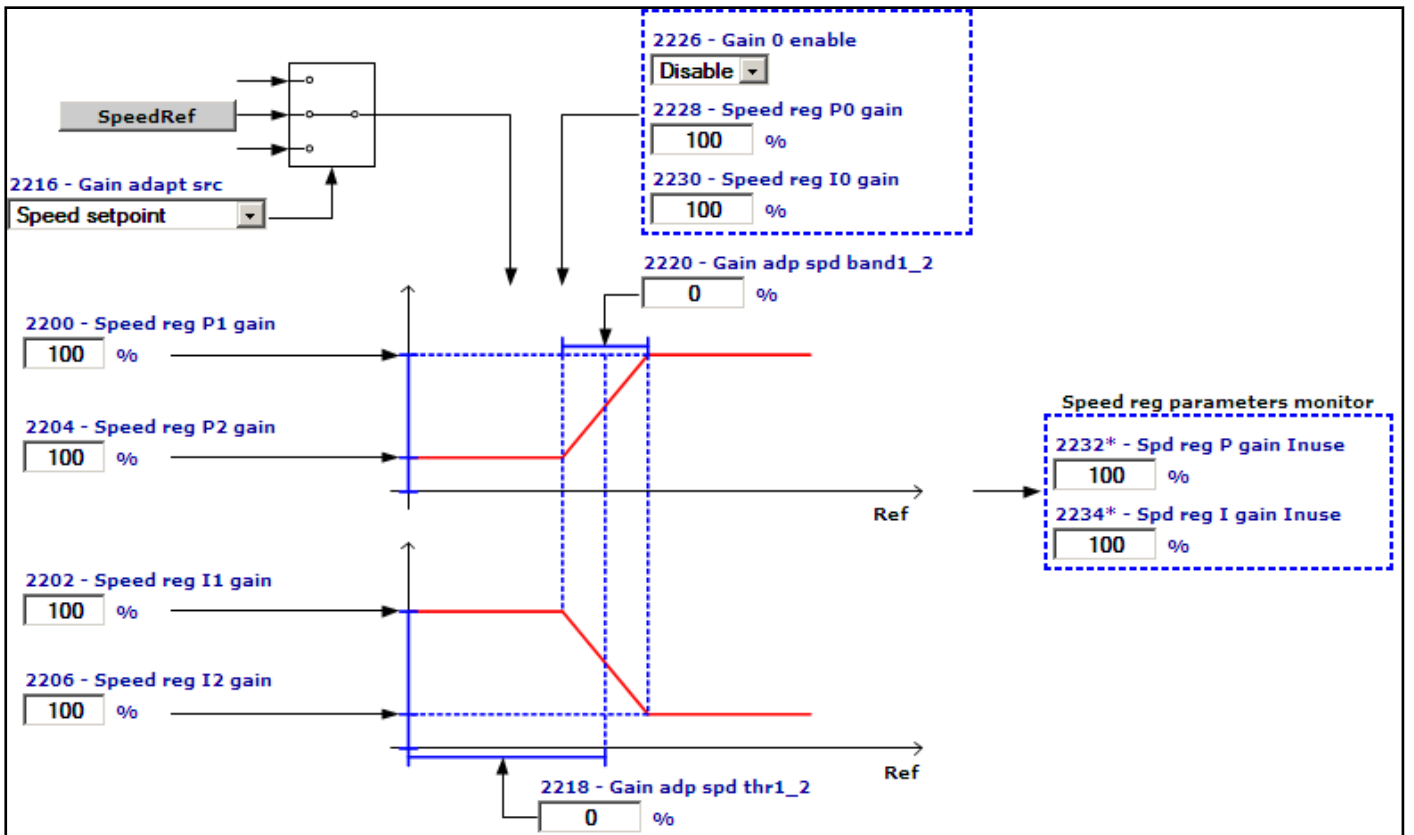

VF parameters

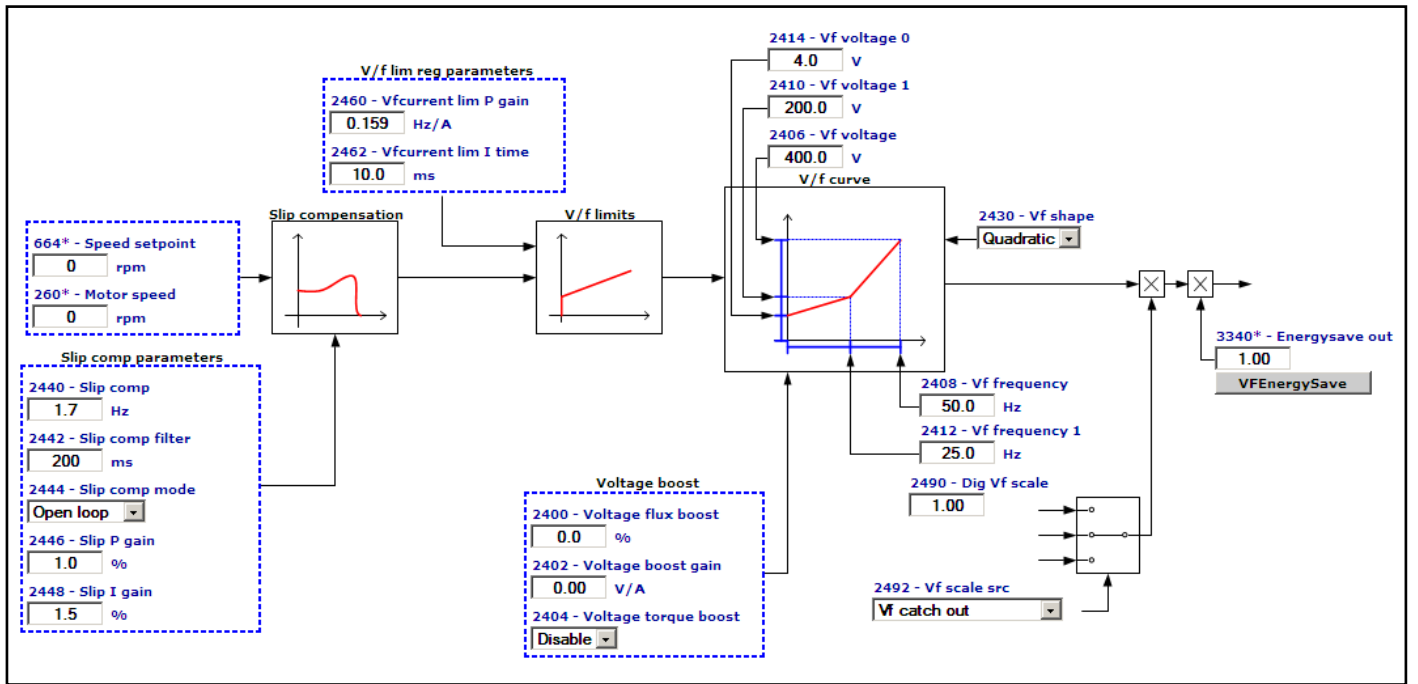

Functions

INERTIA COMP	InertiaComp
DC BRAKING	DCBraking
MOTOR OVERLOAD	MotOvld
BRES OVERLOAD	BresOvld
POWER LOSS	PowerLoss
COMPARE	Compare
BRAKE CONTROL	BrakeCtrl
VF ENERGY SAVE	VFEnergySave

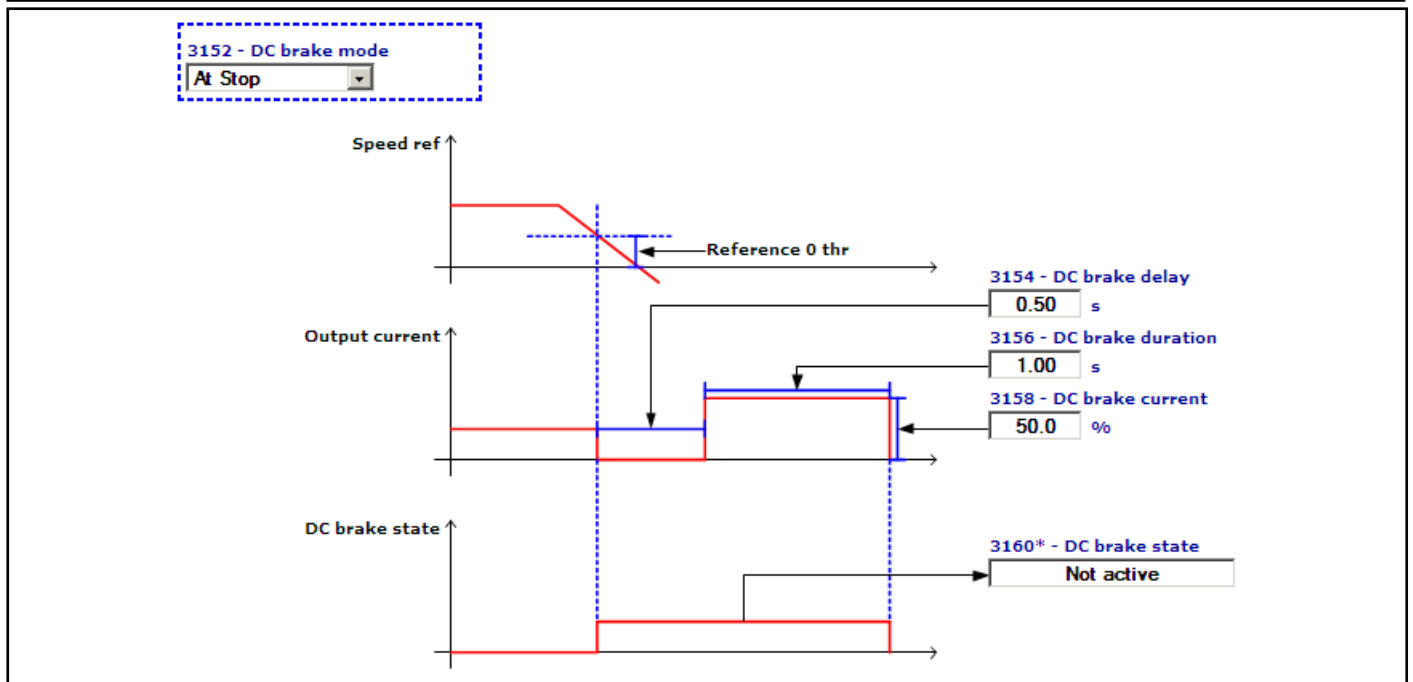
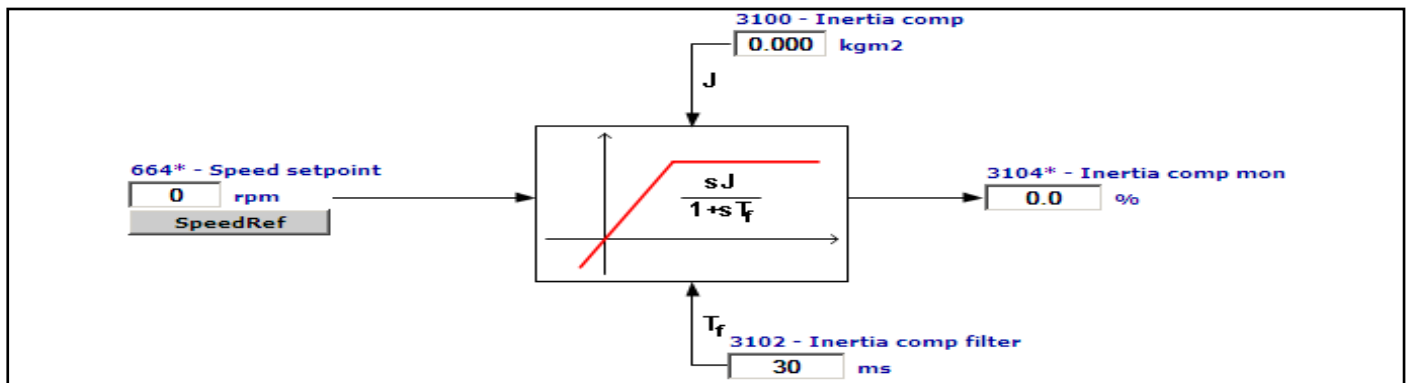

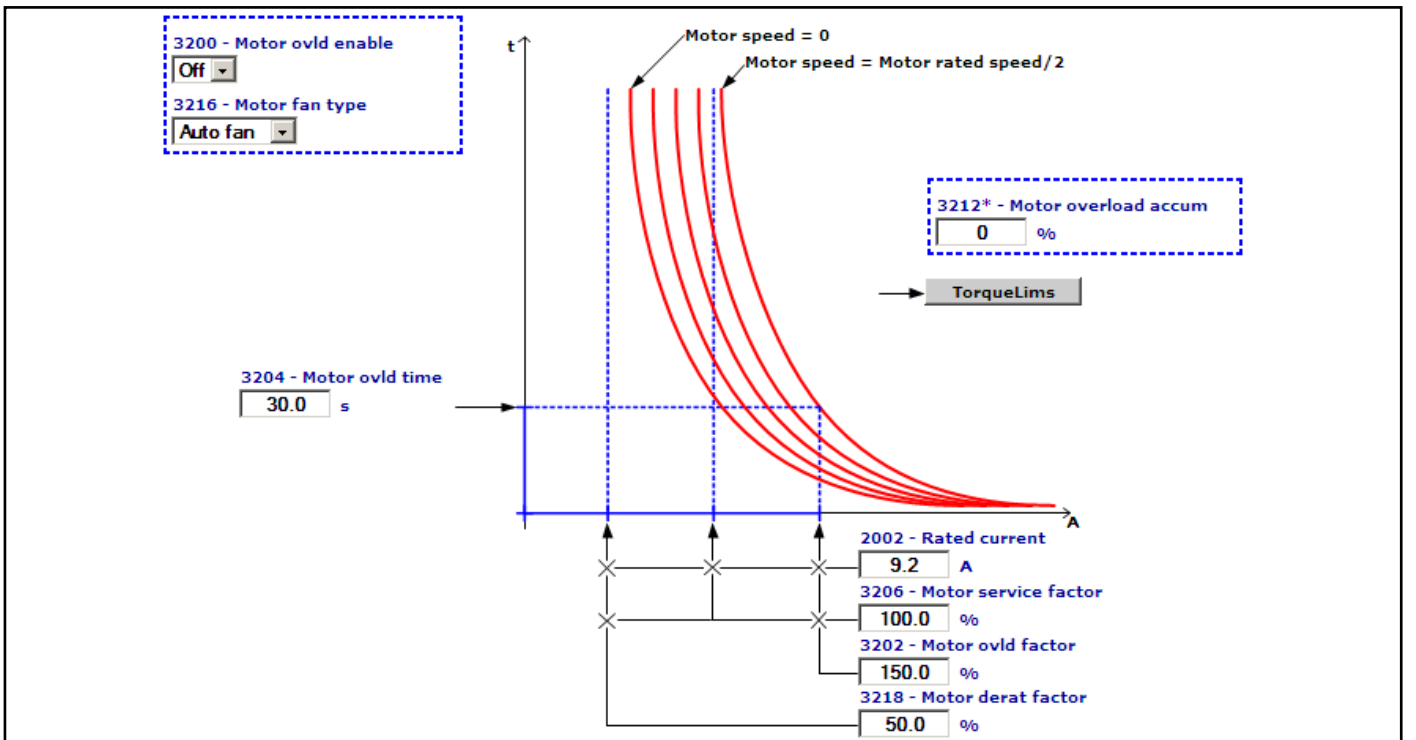
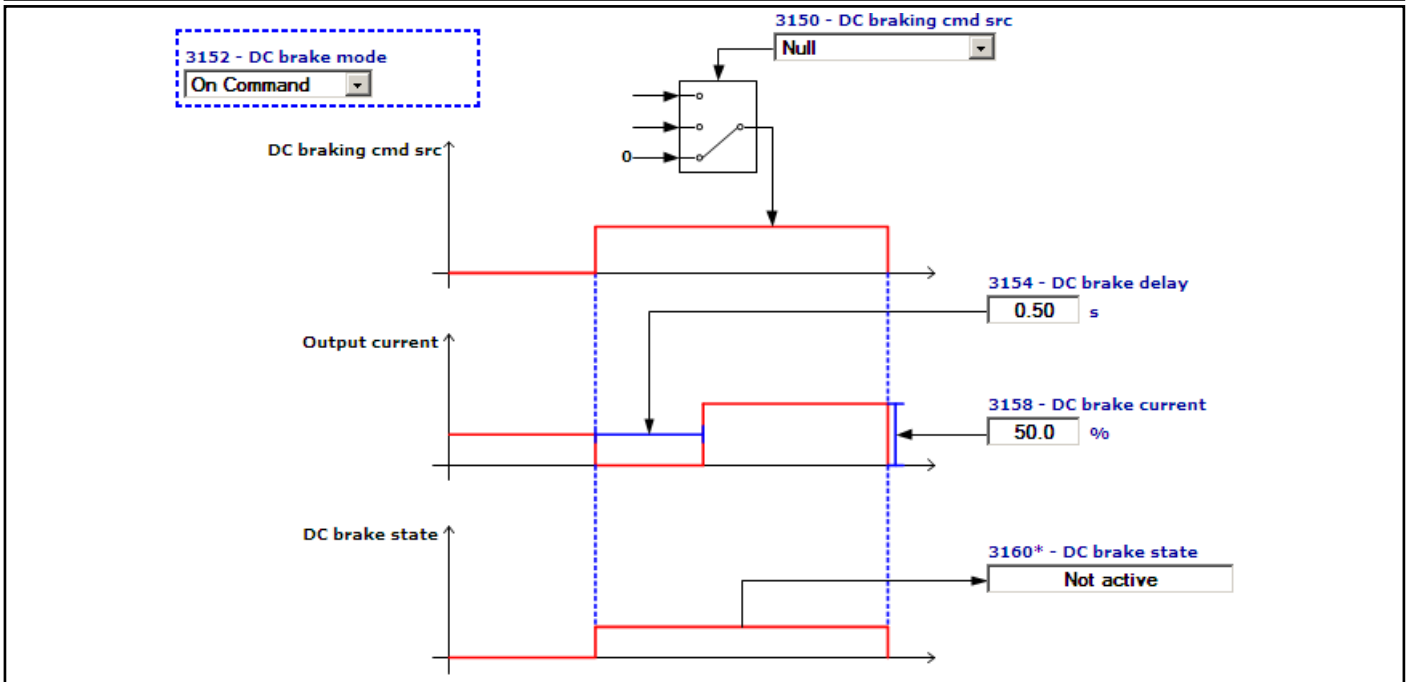
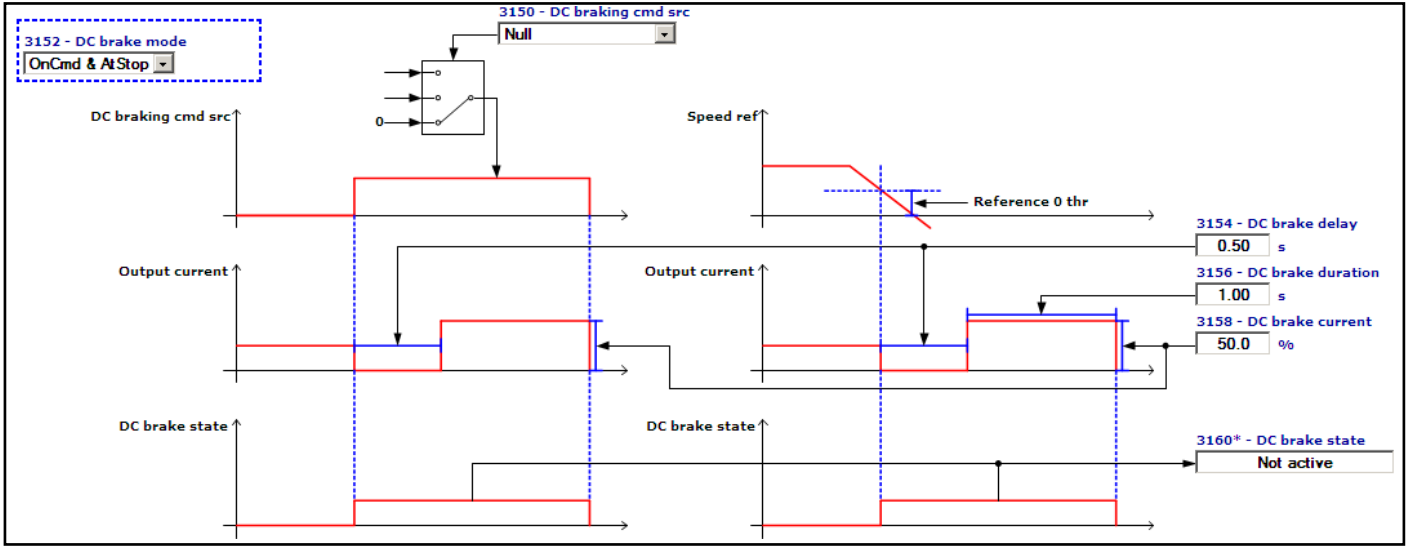

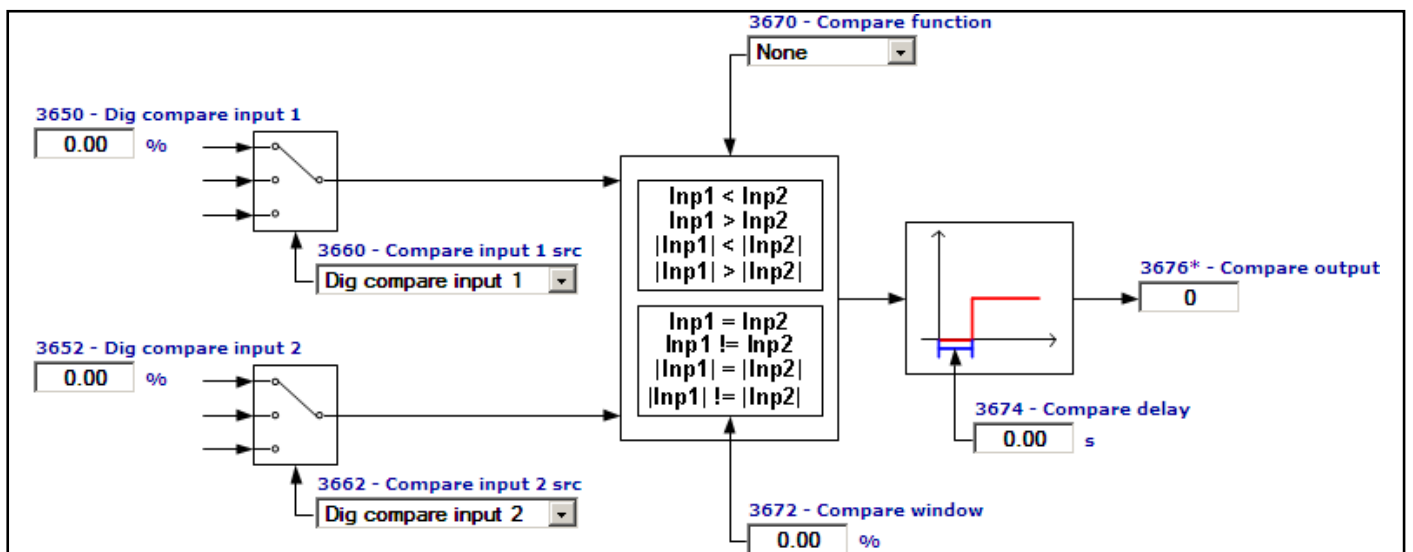
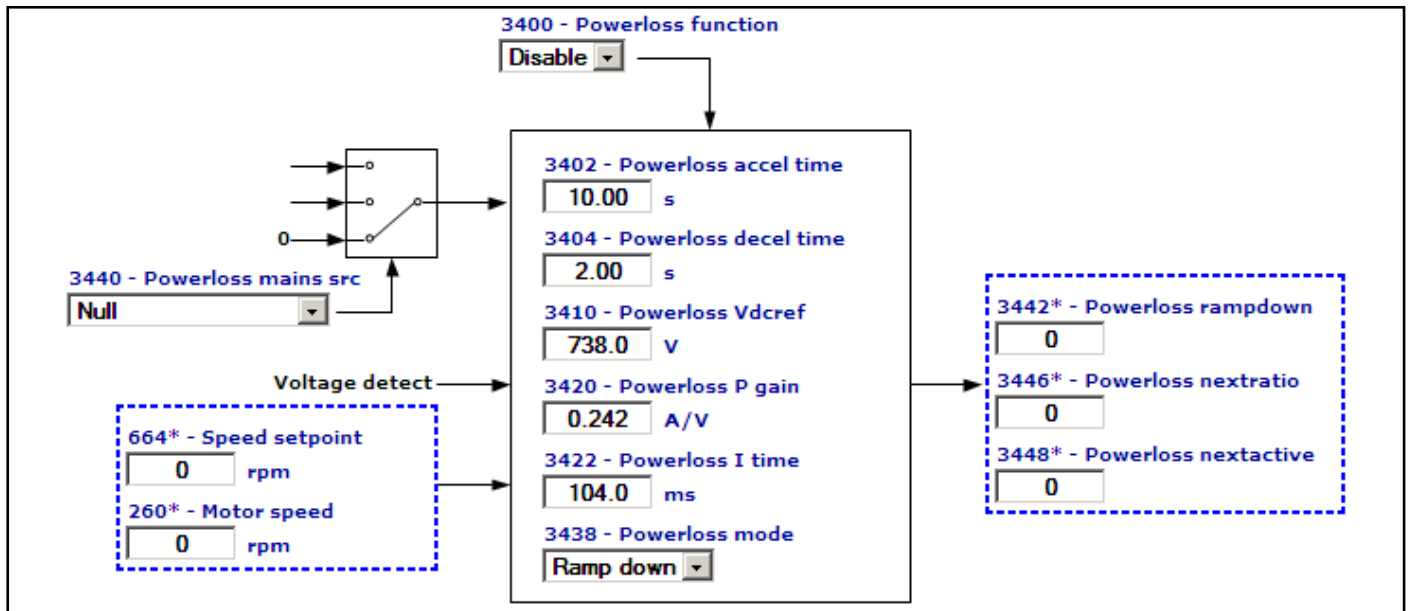
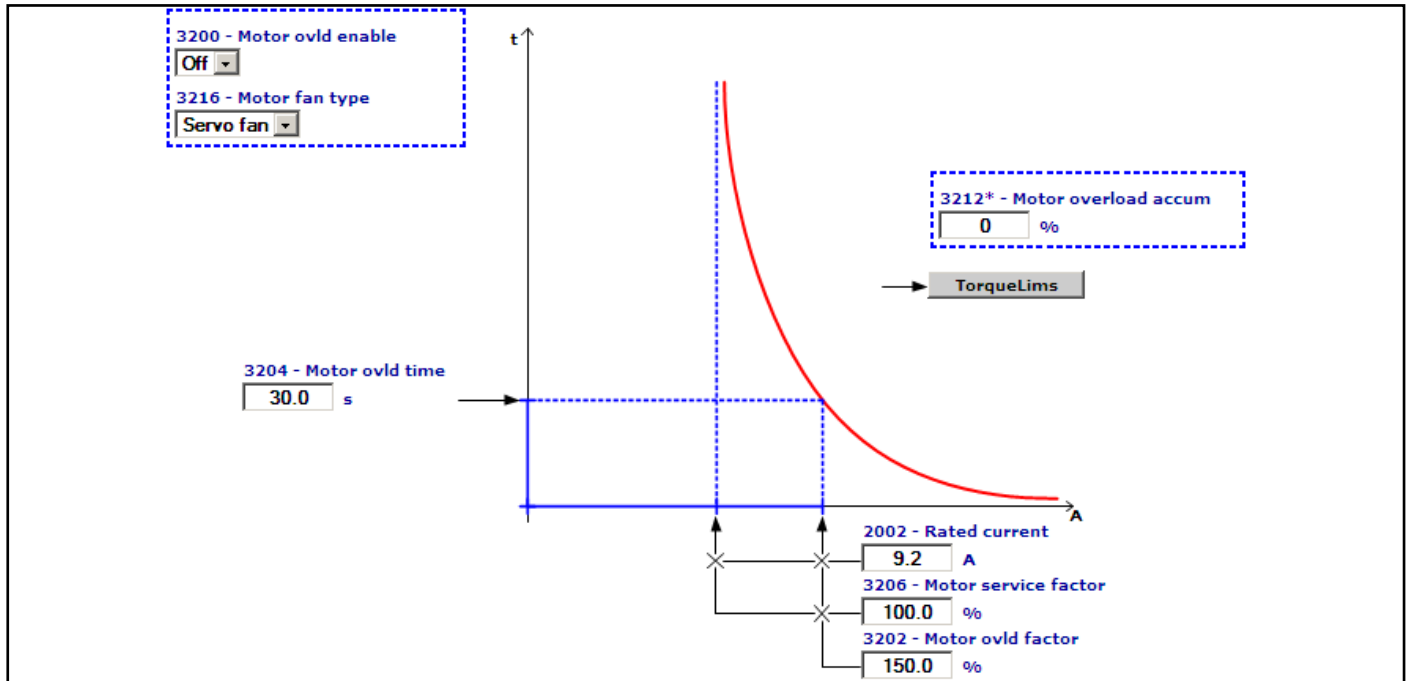

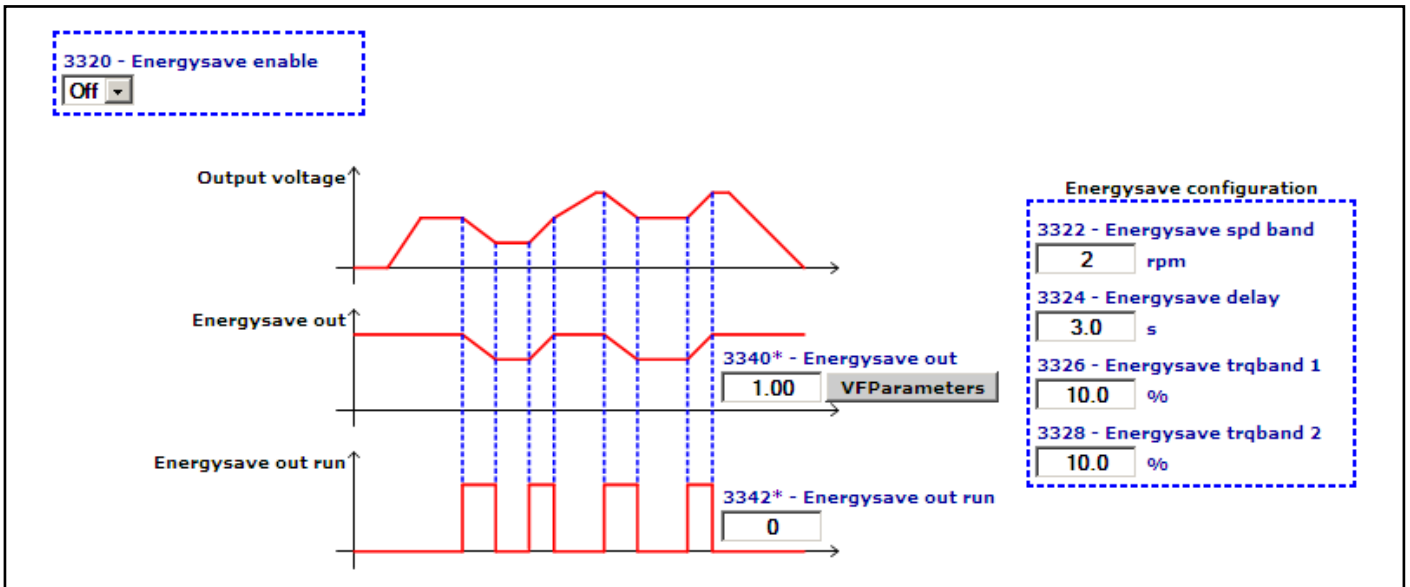
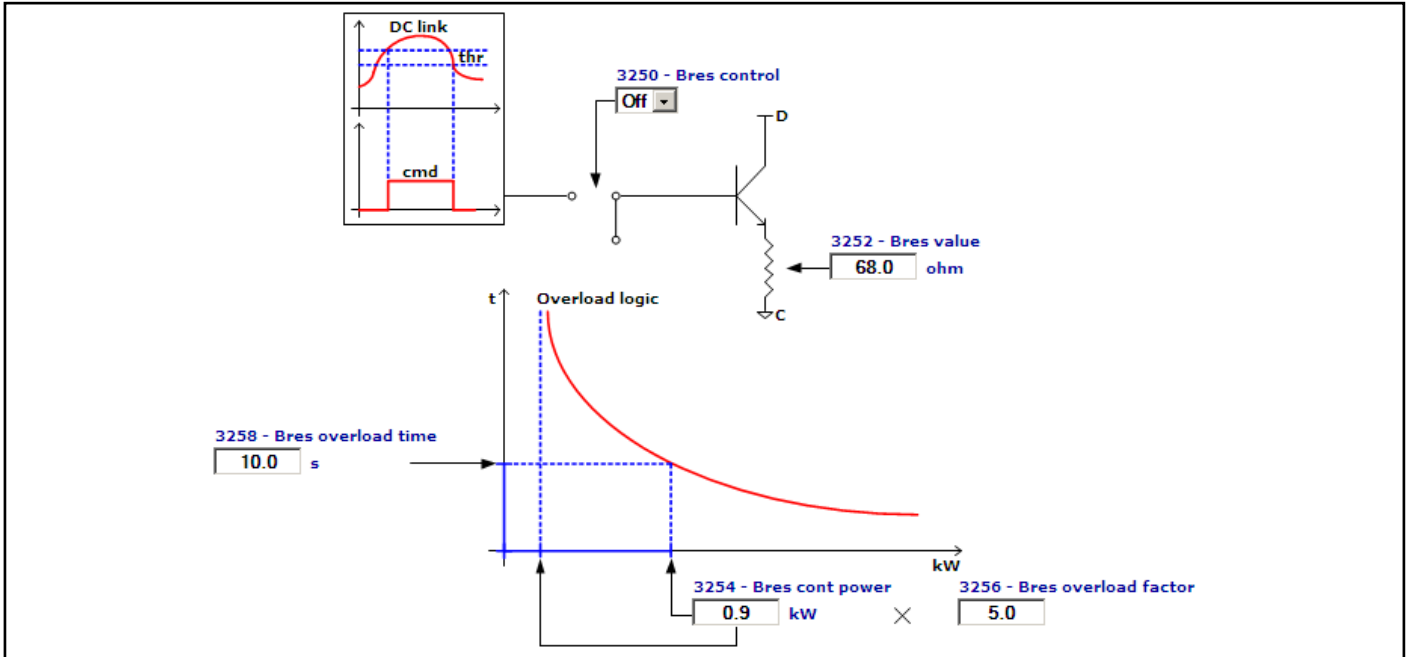
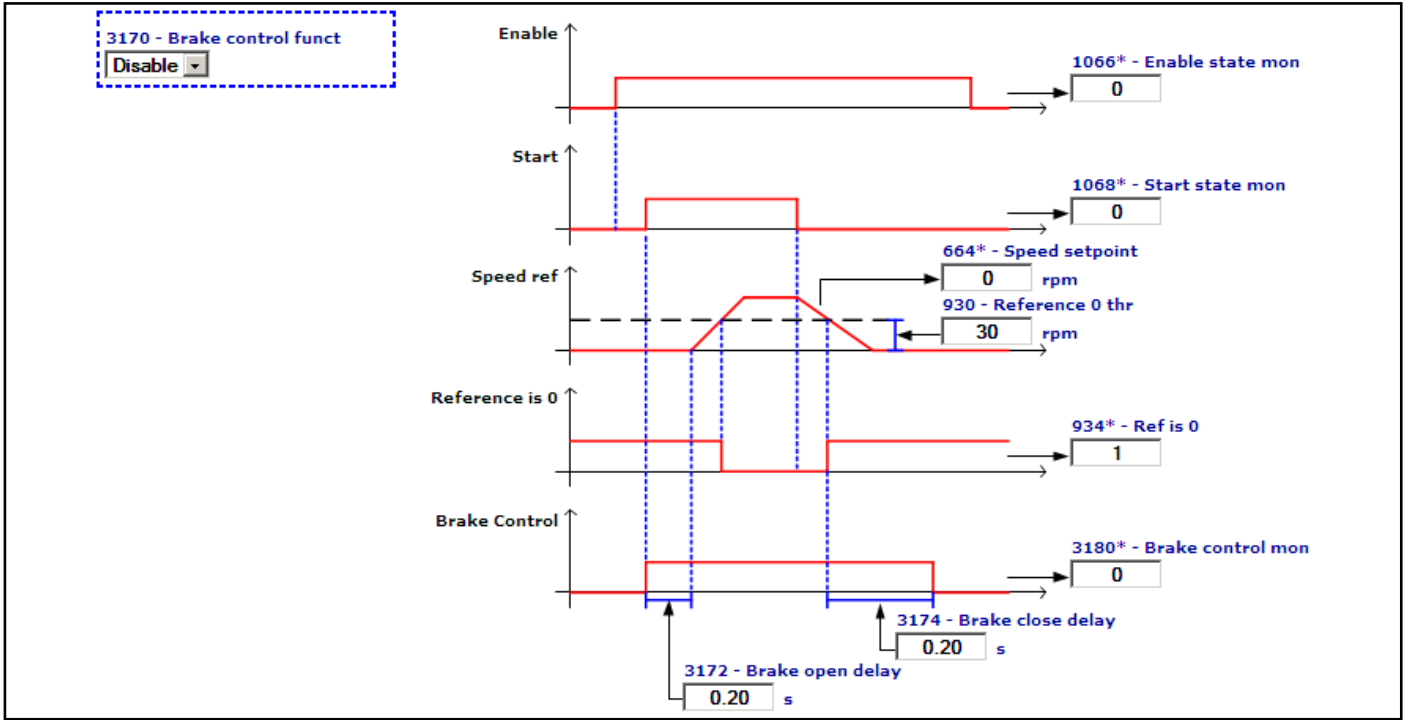

Process

PID1 REFERENCES	PID1Ref	Fill	FILL
PID1	PID1	MinFreq	MIN FREQUENCY
PID2 REFERENCES	PID2Ref	CheckValve	CHECK VALVE
PID2	PID2	PumpClean	PUMP CLEAN
SLEEP MODE	SleepMode	LowPowerCalc	LOW POWER CALC
FLOW COMPENSATION	FlowComp	MultiPump	MULTI PUMP

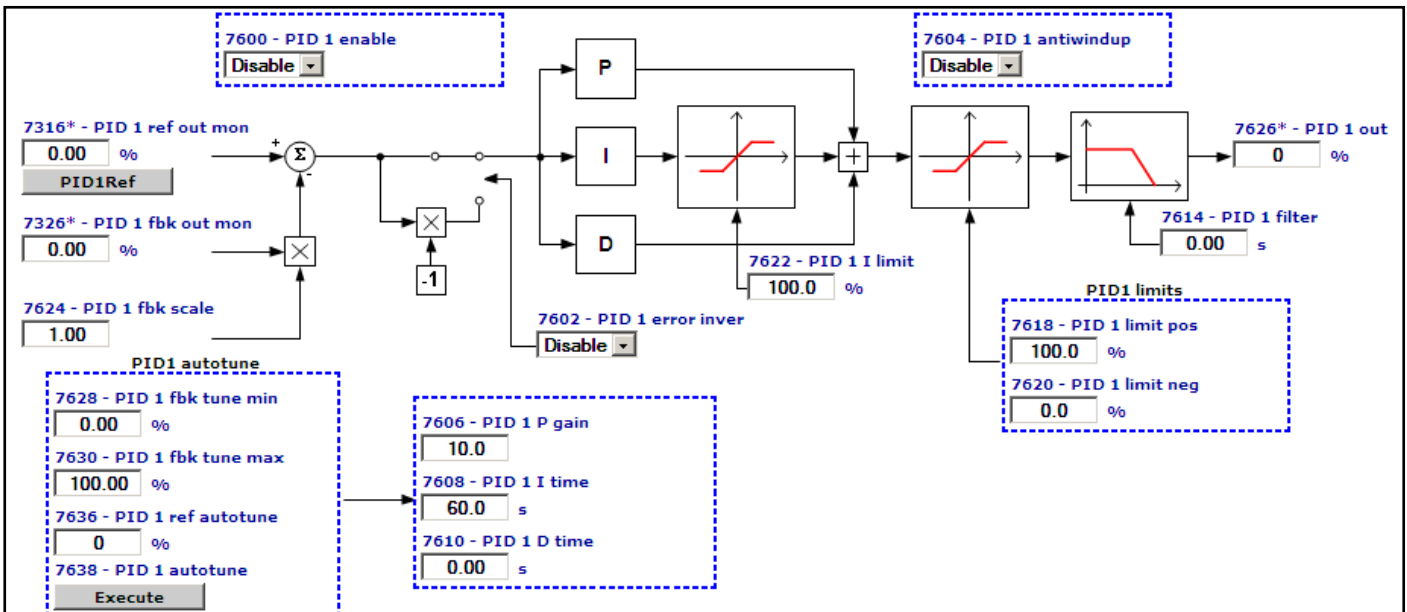
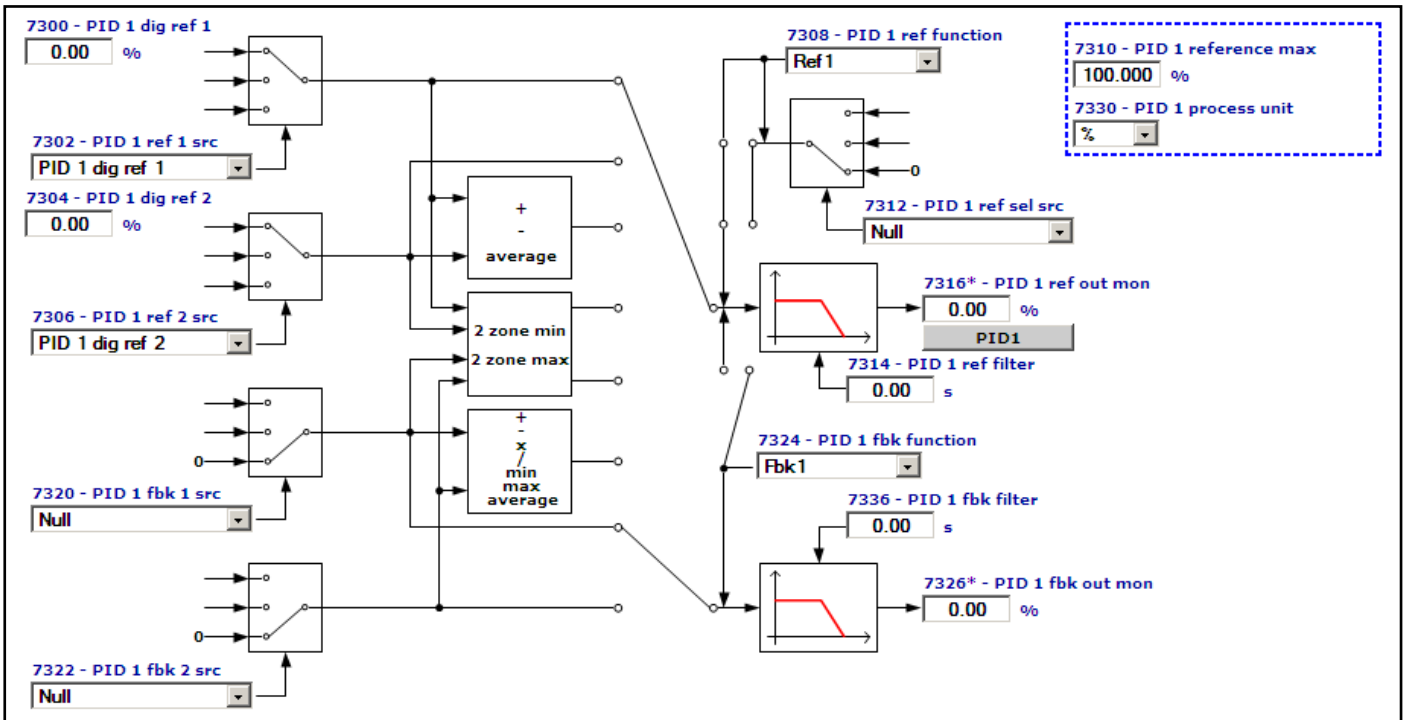

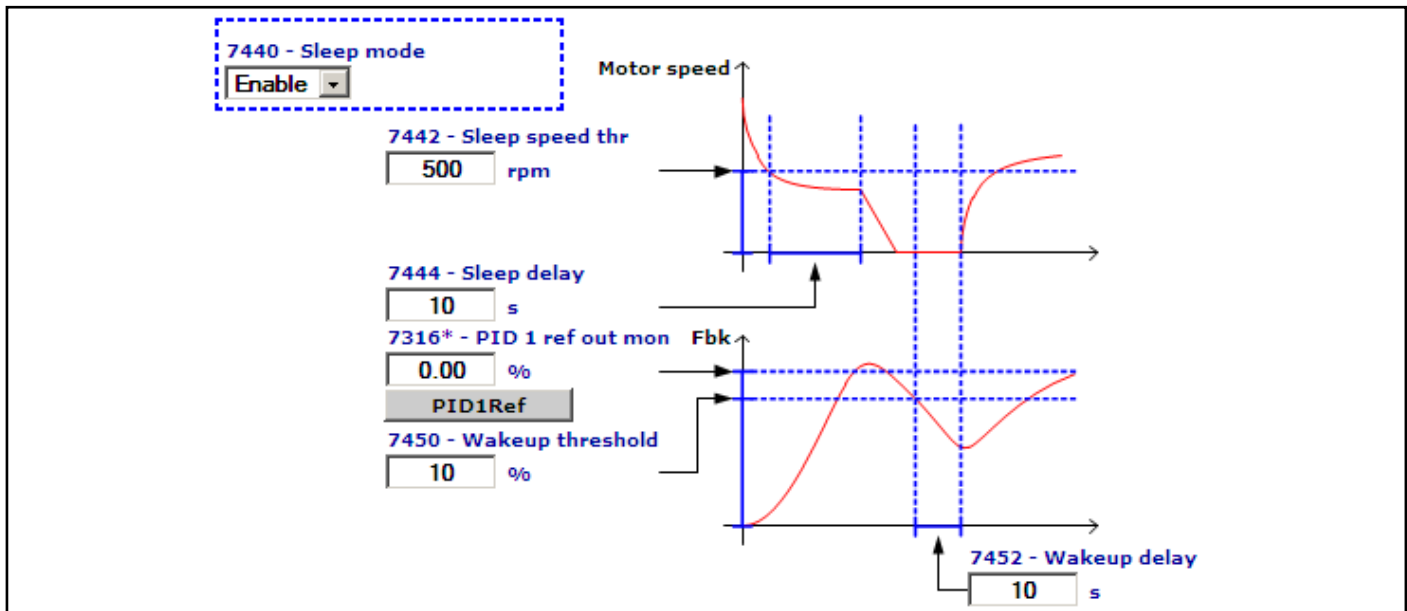
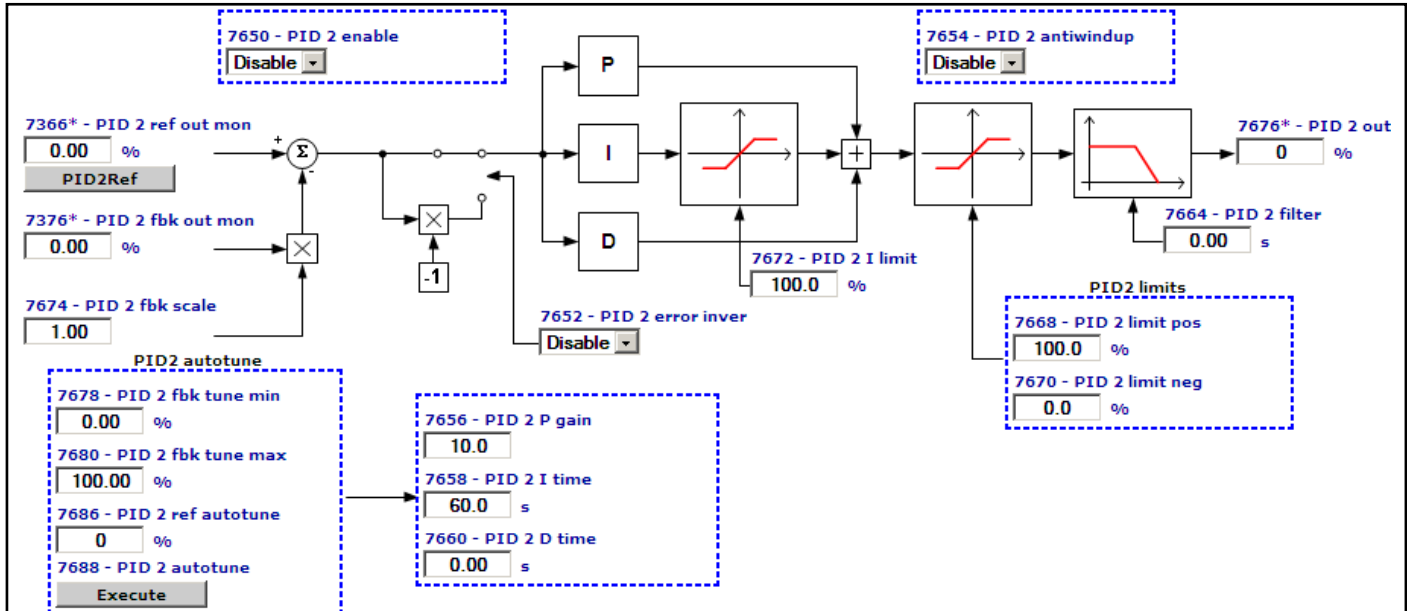
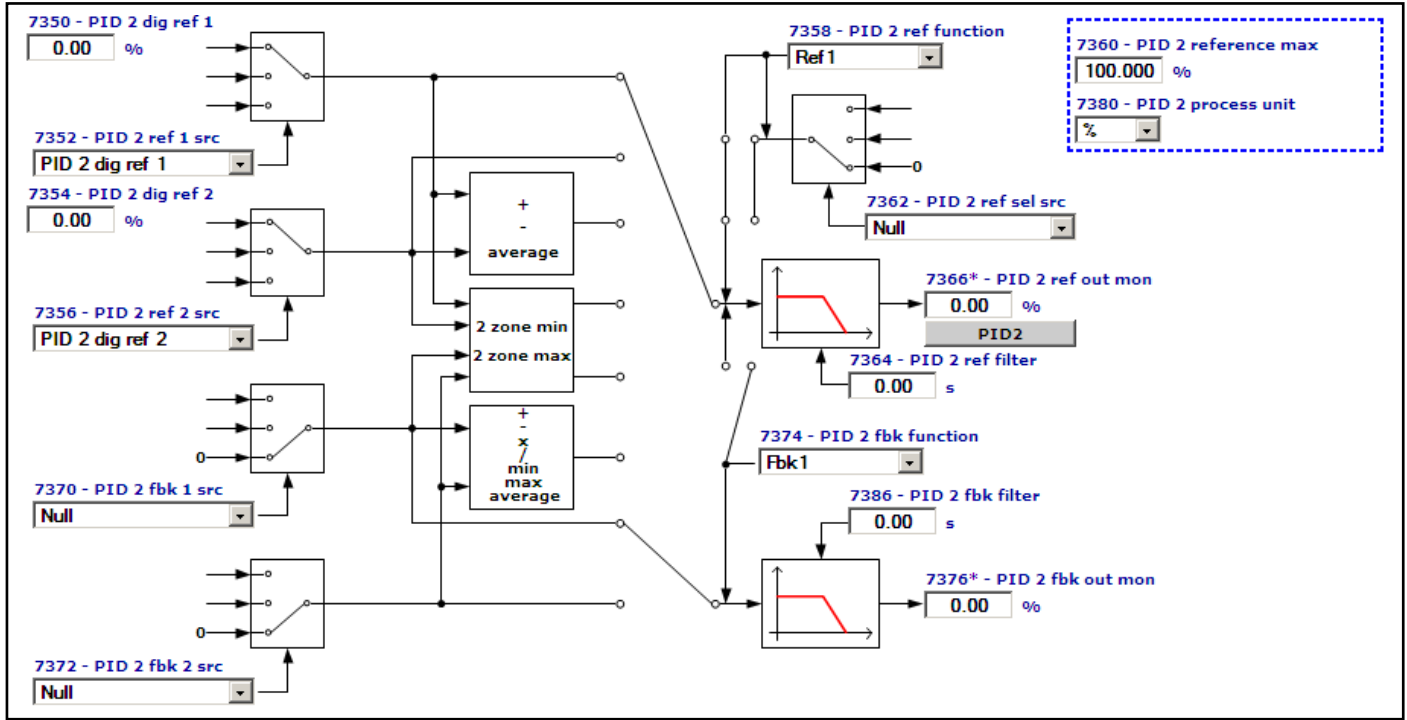

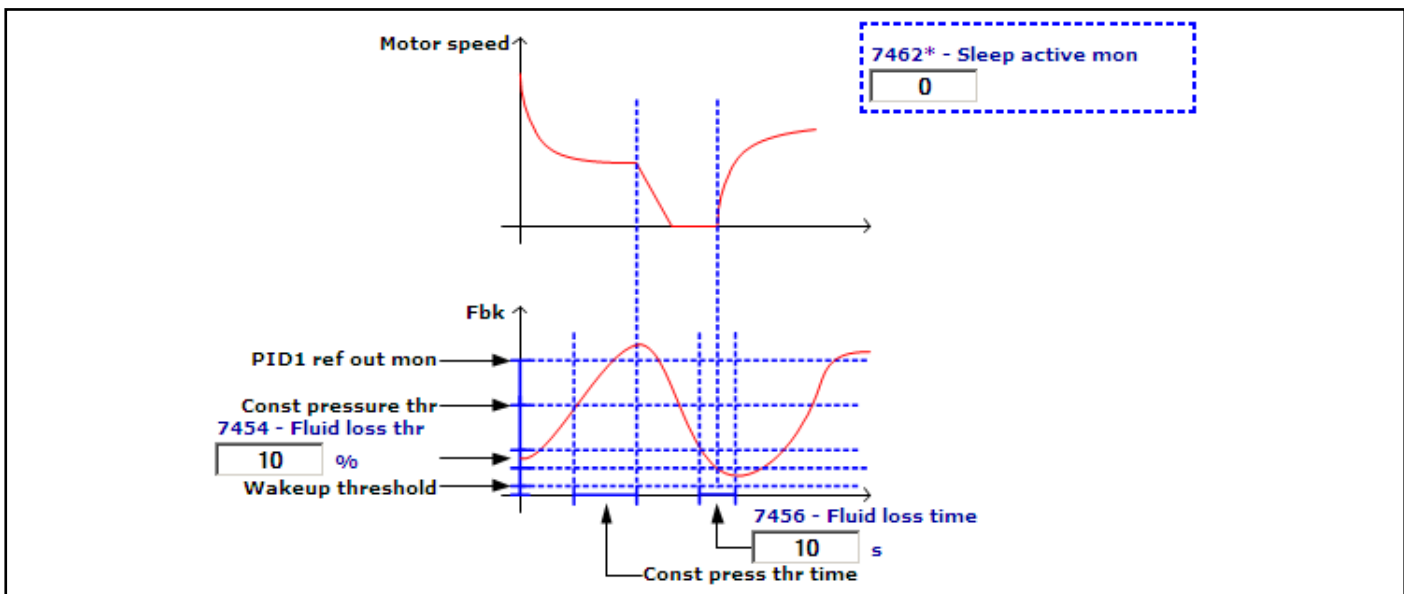
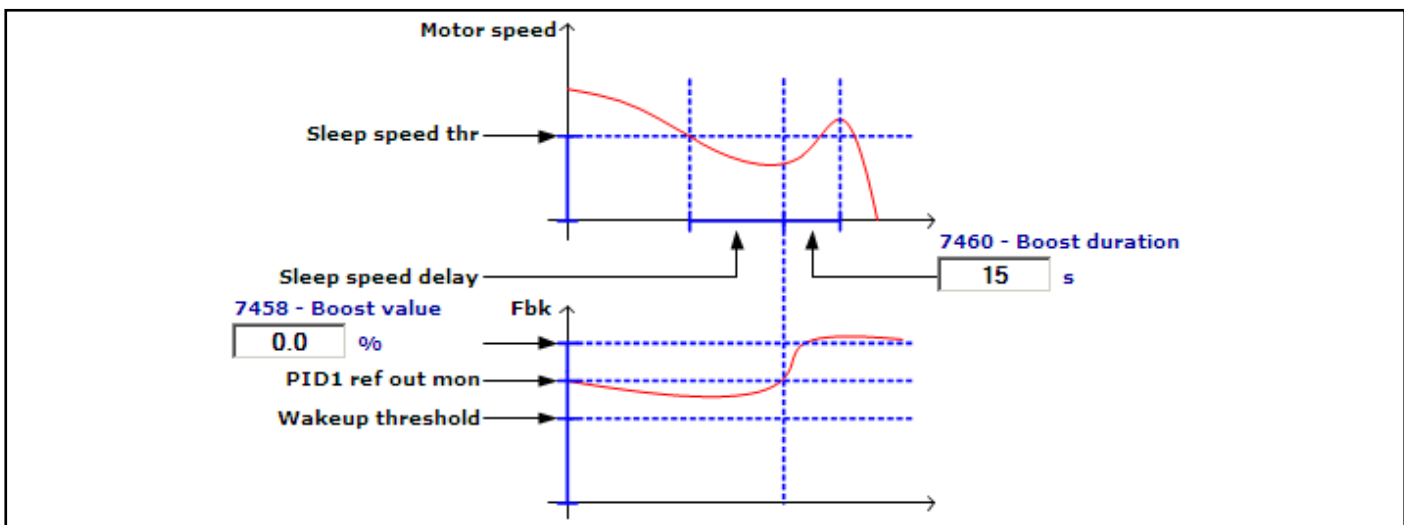
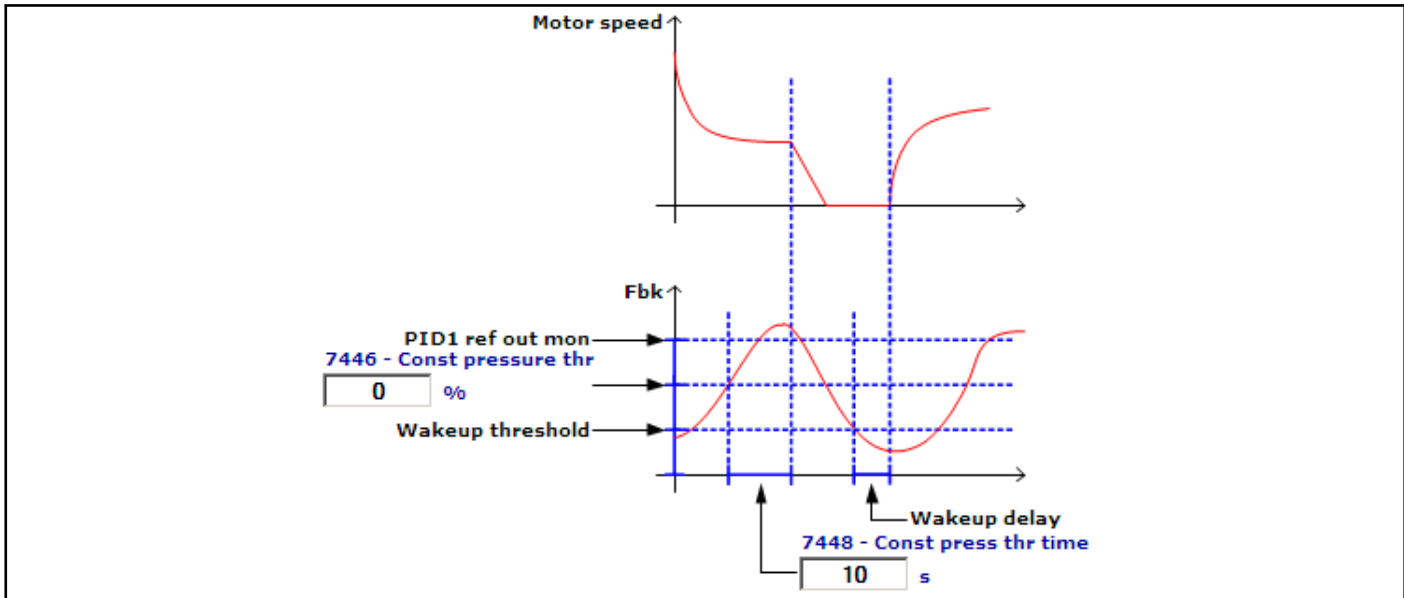

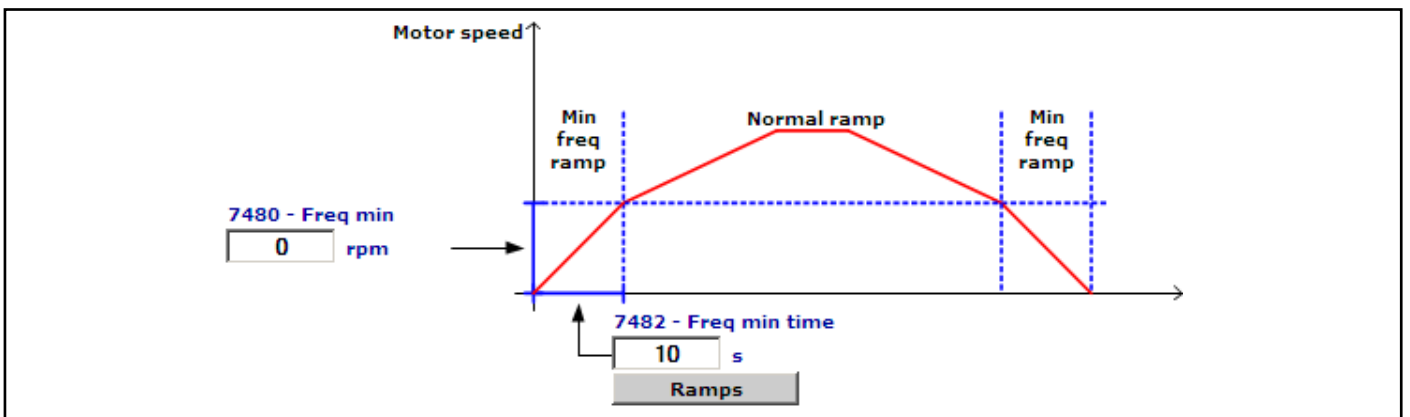
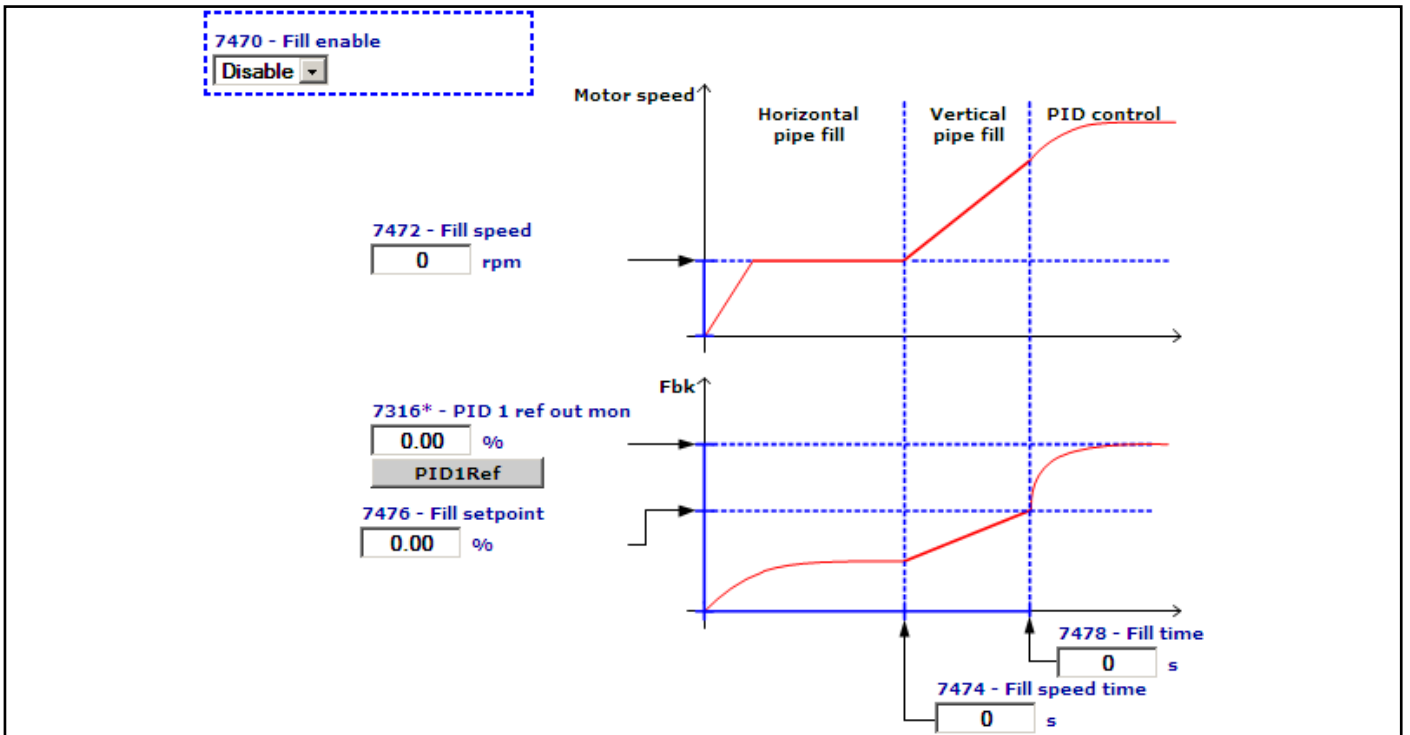
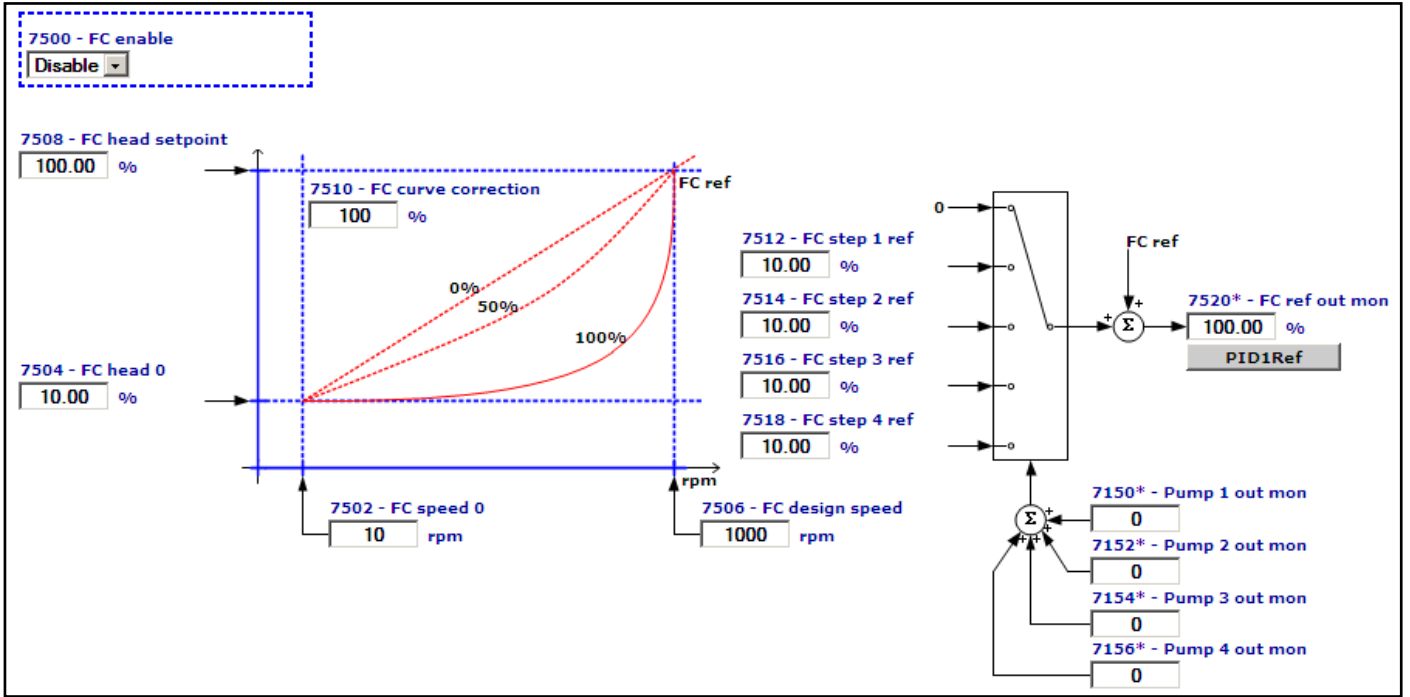

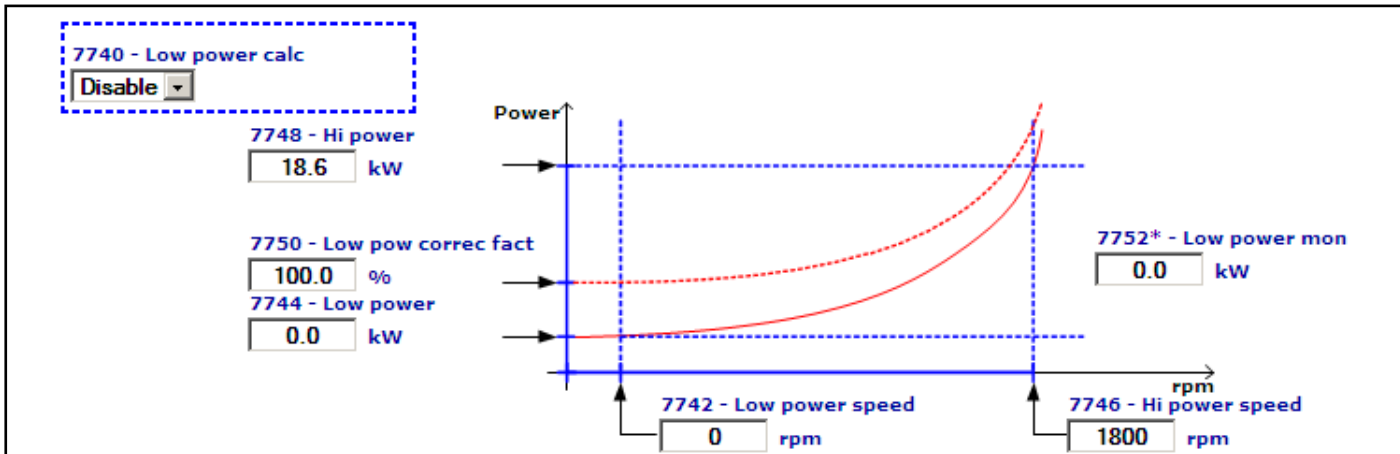
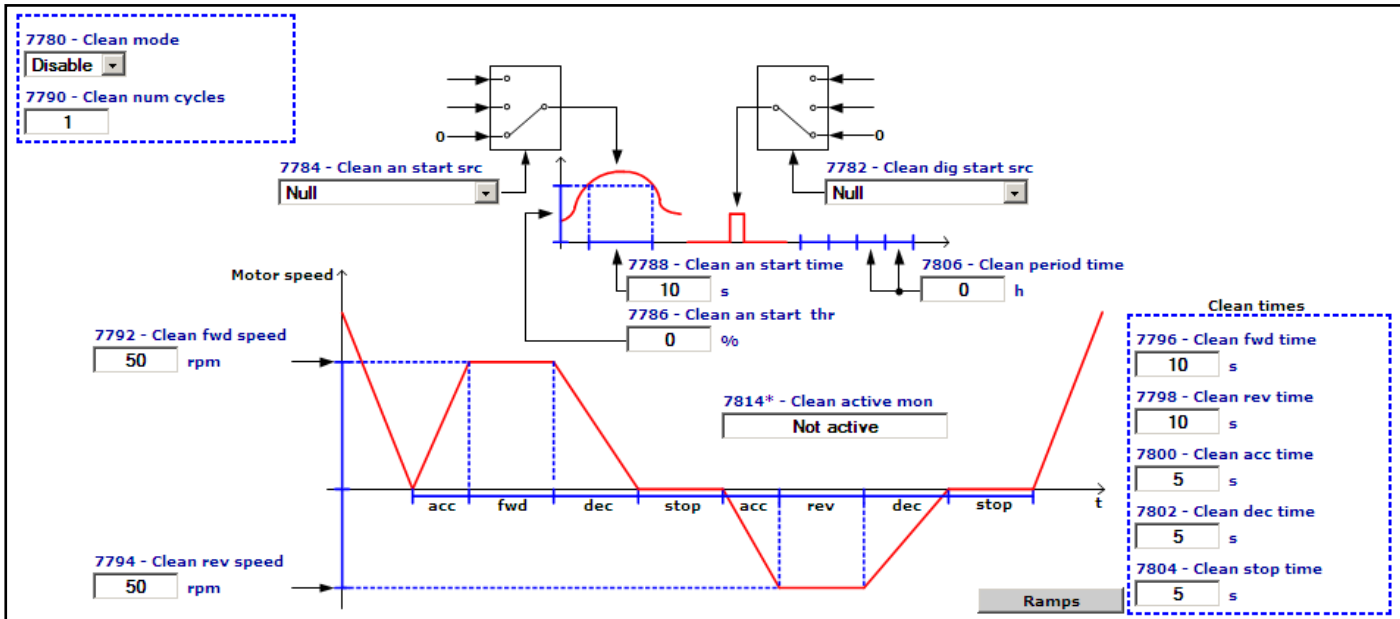
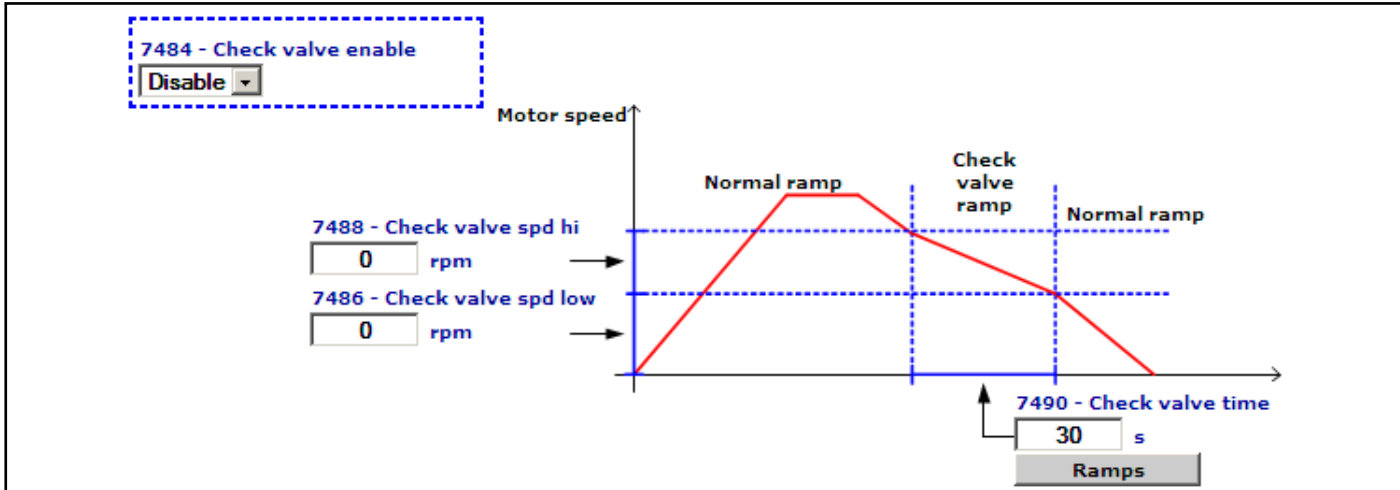

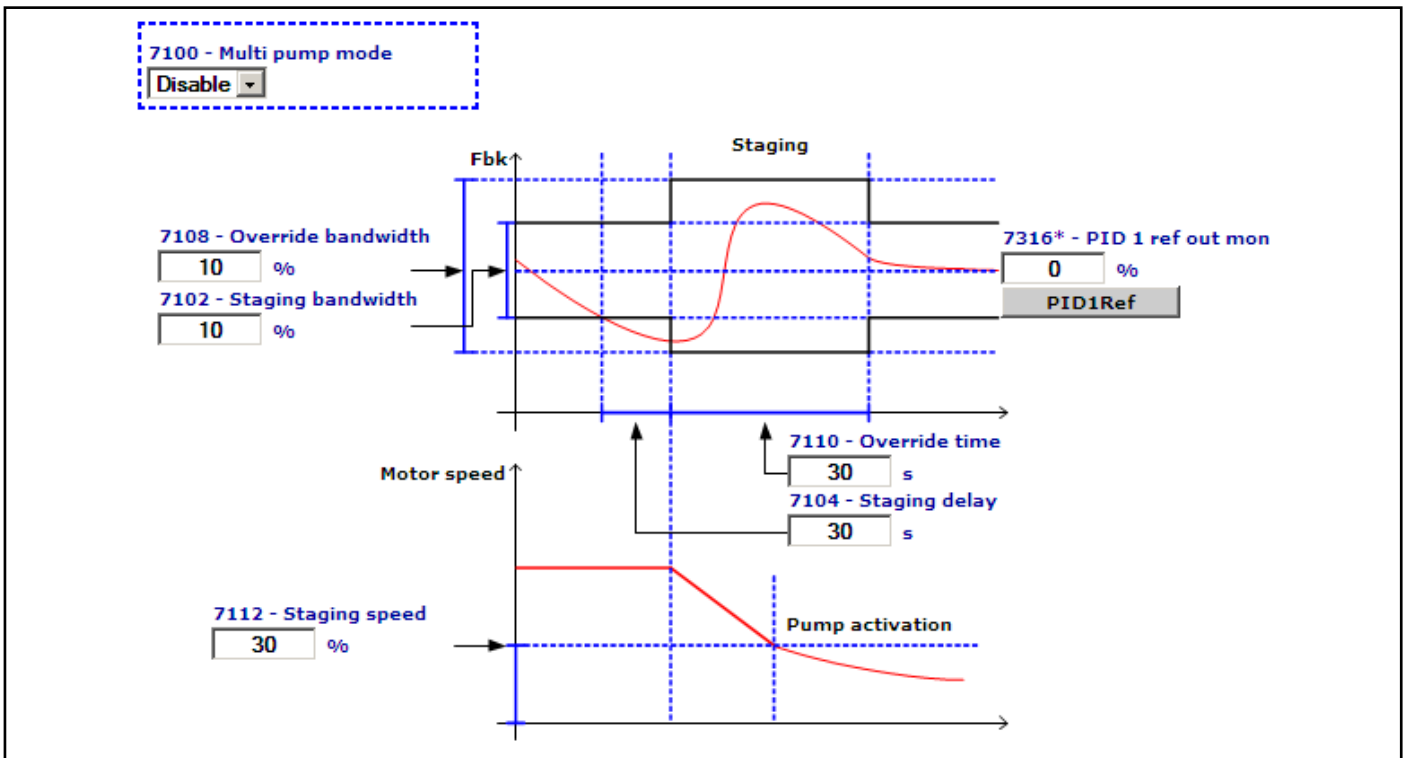
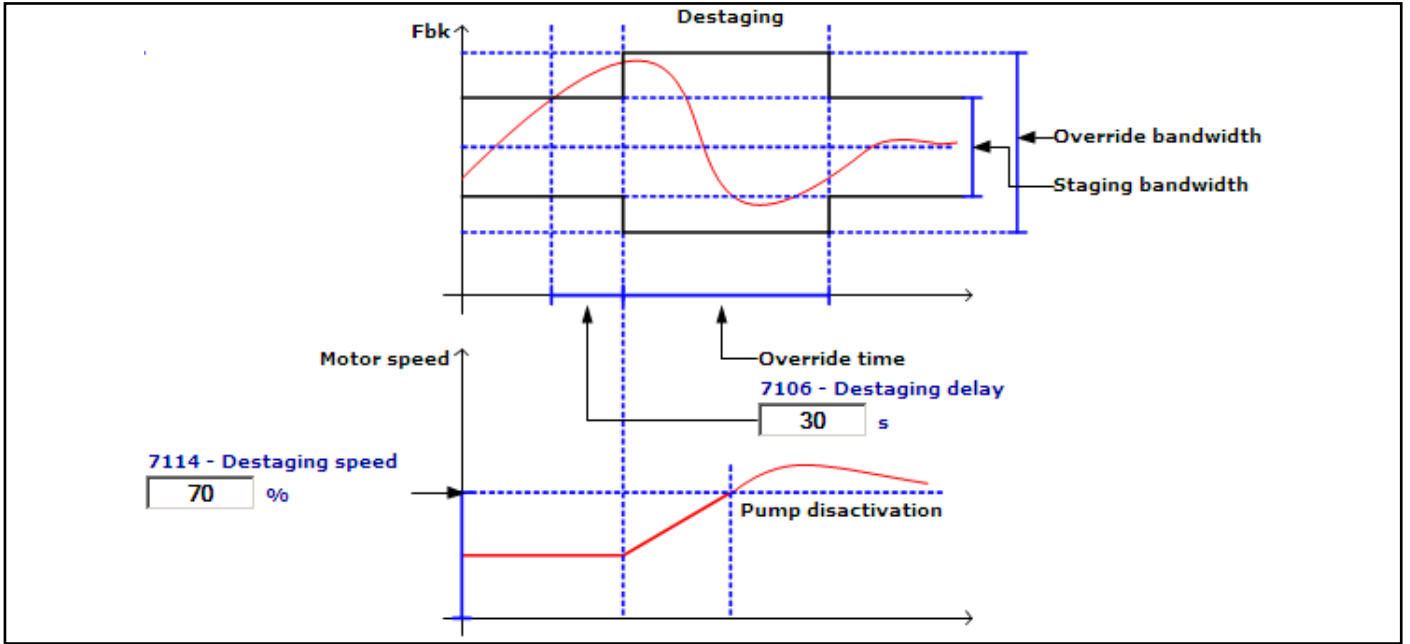

SOLAR PUMPS

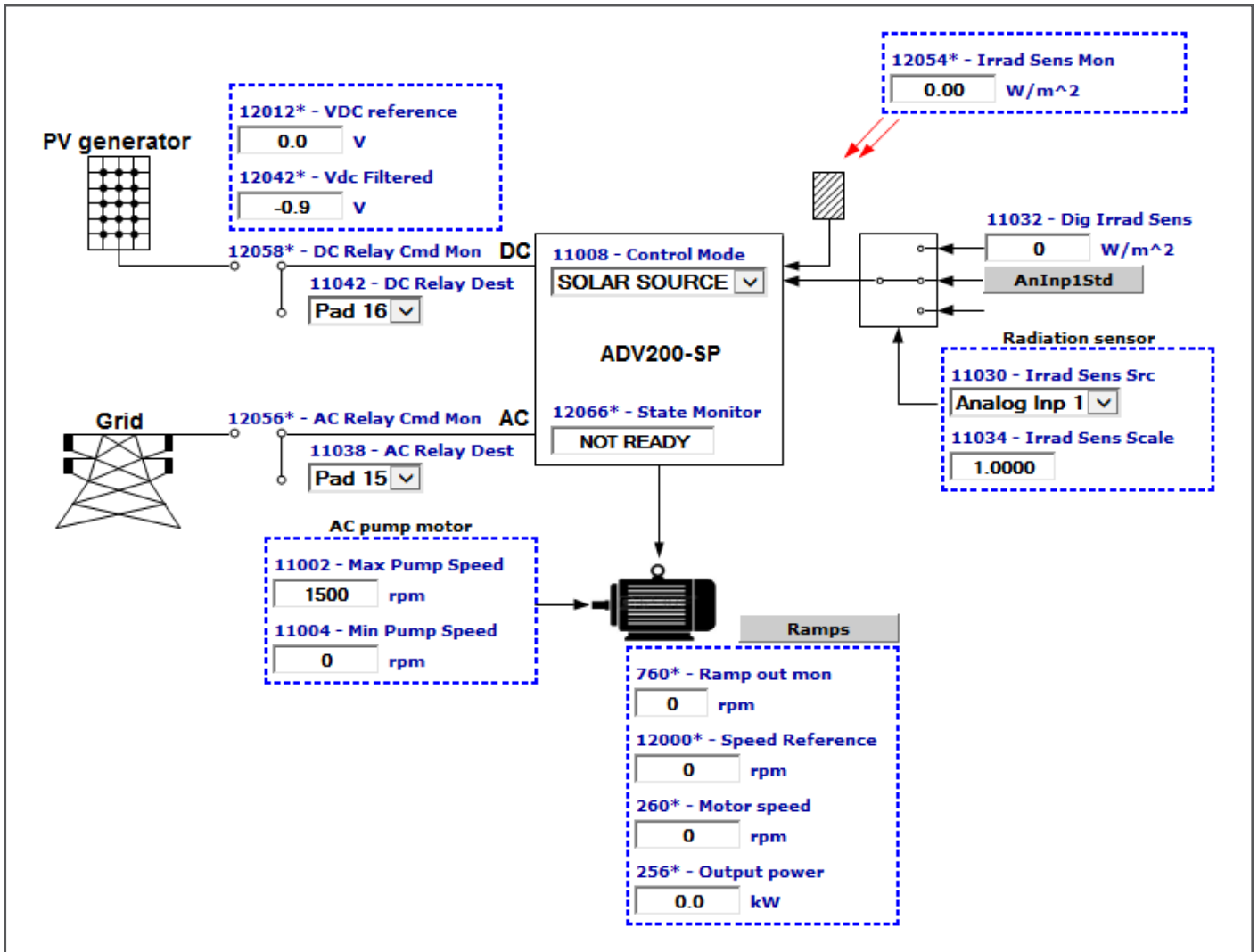

SW Manual

Series: ADV200 SP

Revision: 0.3

Date: 17-11-2022

Code: 1S9SFEN

WEG Automation Europe S.r.l.

Via Giosuè Carducci, 24

21040 Gerenzano (VA) · Italy