

INSTRUCTION FOR 500A TO 800A FRONT MOUNT TYPE CIRCUIT BREAKERS

DANGER

RISK OF ELECTRIC SHOCK, BURN OR EXPLOSION

- 1) This equipment must be installed and serviced only by qualified electrical personnel.
- 2) Turn off and lock out all power supplying this equipment before working on or inside equipment.
- 3) Replace all devices, doors, and covers before turning on power to this equipment.
- 4) Always verify that no voltage is present before working on or inside equipment, and always follow generally accepted safety procedures.

FAILURE TO FOLLOW THESE INSTRUCTIONS WILL RESULT IN DEATH OR SEVERE INJURY.

WEG is not liable for the misapplication or incorrect installation of its products.

The user is cautioned to observe all recommendations, warnings and cautions relating to the safety of personnel and equipment as well as general and local health and safety laws, codes and procedures.

1. CIRCUIT BREAKER INSTALLATION

Make sure that the equipment is suitable for the installation by comparing nameplate ratings with system requirements. Inspect the equipment for completeness and check for any damage.

DANGER

RISK OF ELECTRIC SHOCK, BURN OR EXPLOSION

- 1) Before mounting the circuit breaker in an electrical system, make sure there is no voltage present where work is to be performed.
- 2) Metallic or live electrical parts inside an enclosure shall be mounted in accordance to minimum clearance. (See Fig. 1)
- 3) All enclosure closing hardware must be installed.

FAILURE TO FOLLOW THESE INSTRUCTIONS WILL RESULT IN DEATH OR SEVERE INJURY.

Dimensions for electrical and mechanical clearance to respect minimum distance from enclosure or compartment walls. (See Fig. 1)

Dimensions : inch (mm)

480 VAC

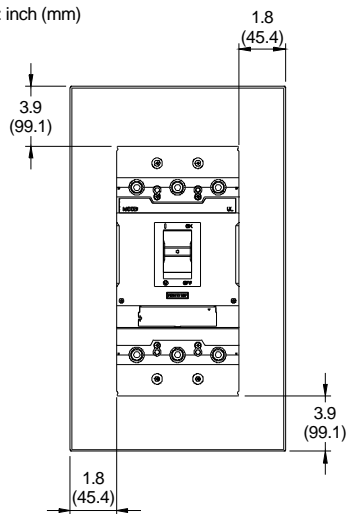

NOTE: for other voltages, please refer to the catalog.

<Fig. 1> Clearance for Circuit Breaker

Circuit breaker mounting steps:

- 1) For individual surface mounting, drill and tap mounting bolts holes according to the drilling plan shown in Fig. 2. For front mounted applications, refer to Fig. 3 for correct dimensions.
- 2) If circuit breaker includes factory- or field-installed internal accessories, make sure that accessory wiring can be reached when the circuit breaker is mounted.
- 3) Remove the line and load lug covers by loosening the two lug cover screws that attach them to the cover.
- 4) Position circuit breaker on mounting surface.
- 5) Install circuit breaker mounting screws and washers.
Tighten hardware securely, but do not exceed 33 pound-inches(3.8N.m.)

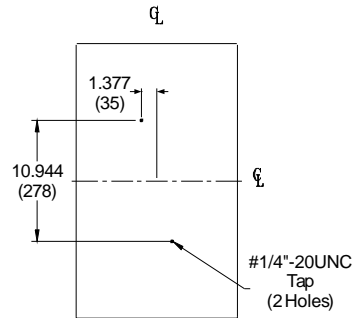

<Fig. 2> Circuit Breaker Drilling template

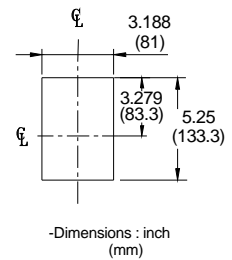

<Fig. 3> Circuit Breaker Front view cut out

2. MANUAL OPERATION

Manual Operation of the circuit breaker is controlled by the circuit breaker handle and the PUSH TO TRIP button. The circuit breaker has three positions, two of which are shown on the cover with raised lettering to indicate ON and OFF. The third position indicates a TRIP position and is between the ON and OFF positions. (See Fig. 4)

Circuit Breaker Reset

After an automatic, accessory initiated trip, or manual PUSH TO TRIP operation, the circuit breaker is reset by moving the circuit breaker handle to the OFF position.

NOTE) In the event of a thermal trip, the circuit breaker cannot be reset until the thermal element in the trip unit cools.

PUSHTO TRIP button

The PUSH TO TRIP button checks the tripping function and is used to manually trip the operating mechanism.

NOTE) Press PUSH TO TRIP button once a year to trip circuit breaker.

• Handle Position Indicator Color

- RED - ON
- GREEN - OFF (RESET)

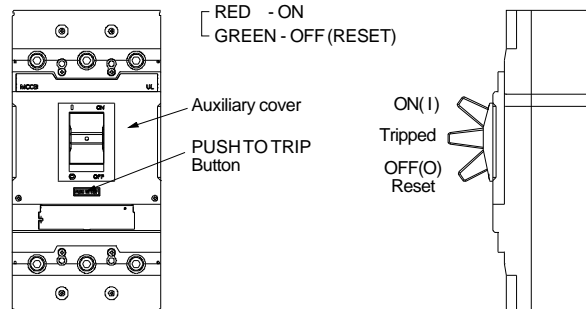

<Fig. 4> Circuit Breaker Manual Controls

3. WIRE INSTALLATION

See circuit breaker nameplate label or optional lug instructions for wire size and torque.

⚠ CAUTION

- 1) Each terminal connector or conductor should be connected as shown in the Fig. 5.
- 2) Do not allow conductor strands to interfere with threads of wire binding screw.
- 3) When installing two cables into a lug body make sure cables do not back out during tightening of the wire binding screw.
- 4) Do not exceed terminal specification when breakers are used without lugs. Tighten with M8 screw and do not exceed 70lb-in.

FAILURE TO FOLLOW THESE INSTRUCTIONS WILL RESULT IN EQUIPMENT DAMAGE.

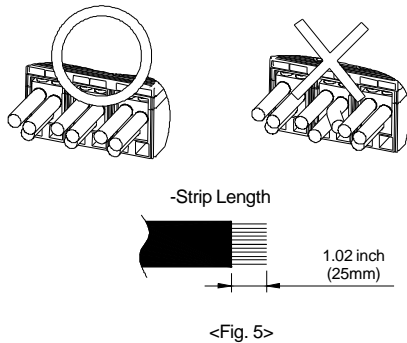

1) Remove line and local lug cover and install wires.

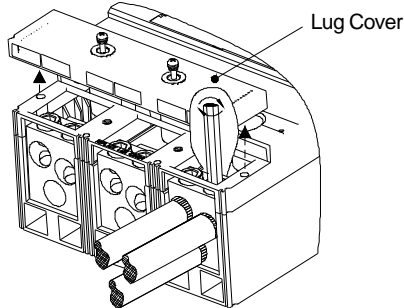

2) Put line and load lug covers back and tighten screws securely.

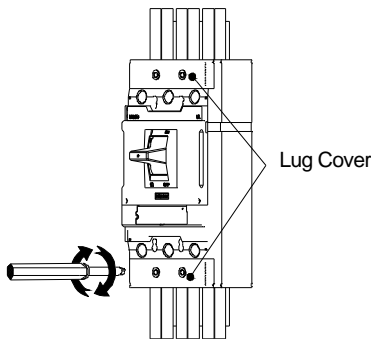

4. CIRCUIT BREAKER REMOVAL

- 1) Turn off all power supplying this equipment before working on or inside equipment.
- 2) Remove circuit breaker in reverse order of installation.

5. ACCESSORIES INSTALLATION (IF REQUIRED)

- 1) Turn off all power supplying this equipment before working on or inside equipment.
Handle must be in TRIP position before opening cover.
- 2) Loosen four screws from the auxiliary cover and open it.
- 3) Install field-installable accessories according to instructions supplied with them.
- 4) Close the breaker cover and secure with screws.
- 5) If circuit breaker has factory-installed accessories, refer to label on circuit breaker for electrical specifications and lead colors.

6. OTHER SAFETY INSTRUCTIONS

Check area where circuit breaker is installed for any safety hazards including personnel safety and fire hazards. Exposure to certain types of chemicals can cause deterioration of electrical connections.

⚠ CAUTION

- 1) No circuit breaker should be reset until the cause of trip is known and the situation rectified.
- 2) Be careful not to damage the equipment during transportation or installation.
- 3) Periodically check terminals and connectors for looseness or signs of overheating.

FAILURE TO FOLLOW THESE INSTRUCTIONS WILL RESULT IN EQUIPMENT DAMAGE.

If any questions arise, contact WEG or refer to the catalog for further information or instructions.

<Fig. 6> DIMENSIONS

