

HVW701 Drive Panels with and without Bypass, Rated for SCCR of 65KA



The WEG HVW701 HVAC-R By-Pass system is comprised of the CFW701 Variable Frequency Drive with integral manual By-Pass. It is designed for heating, ventilation, air conditioning and refrigeration systems where continued operation is critical and space is at a premium. The HVW701 is designed to provide reliable and energy-efficient control for applications in office buildings, hospitals, airports, hotels, shopping centers or other similar facilities. The HVW701 is rated for Short circuit current rating (SCCR) of 65KA and offers Damper Control, too.



Standard Features

- Ratings:
 - 2 to 75HP @ 3/208VAC, 3-Phase to 3-Phase. Can easily be converted to 3/230VAC.
 - 3 to 150HP @ 3/460VAC, 3-Phase to 3-Phase.
- Main 65KAIC rated Circuit breaker with through the door rotary handle.
- VFD line side fuses (for enclosure frame-HV1 and HV2).
- CFW701 – HVAC-R drive with dual DC choke built in & RFI Filter.
- 3-Contactor manual mechanical bypass option allows motor to start/run across the line and power up the VFD for programming &/or troubleshooting simultaneously.
- Damper control.
- Fused Control power transformer (120VAC).
- Enclosure door mounted: VFD - Byp/Test - Byp & HOA Selector switches; VFD Run, System fault and Bypass Run Pilot lights. (Only for 3-Contactory bypass Option).
- HVAC functions like: Energy Saving, Fire Mode, Protection against short cycles, Dry Pump, Broken Belt, Filter maintenance Alarm, Sleep Mode, Total of three PID.
- Communication: BACnet, Metasys N2 and Modbus-RTU embedded through RS-485 port.



HVW701

HVW701 Catalog Number Sequence

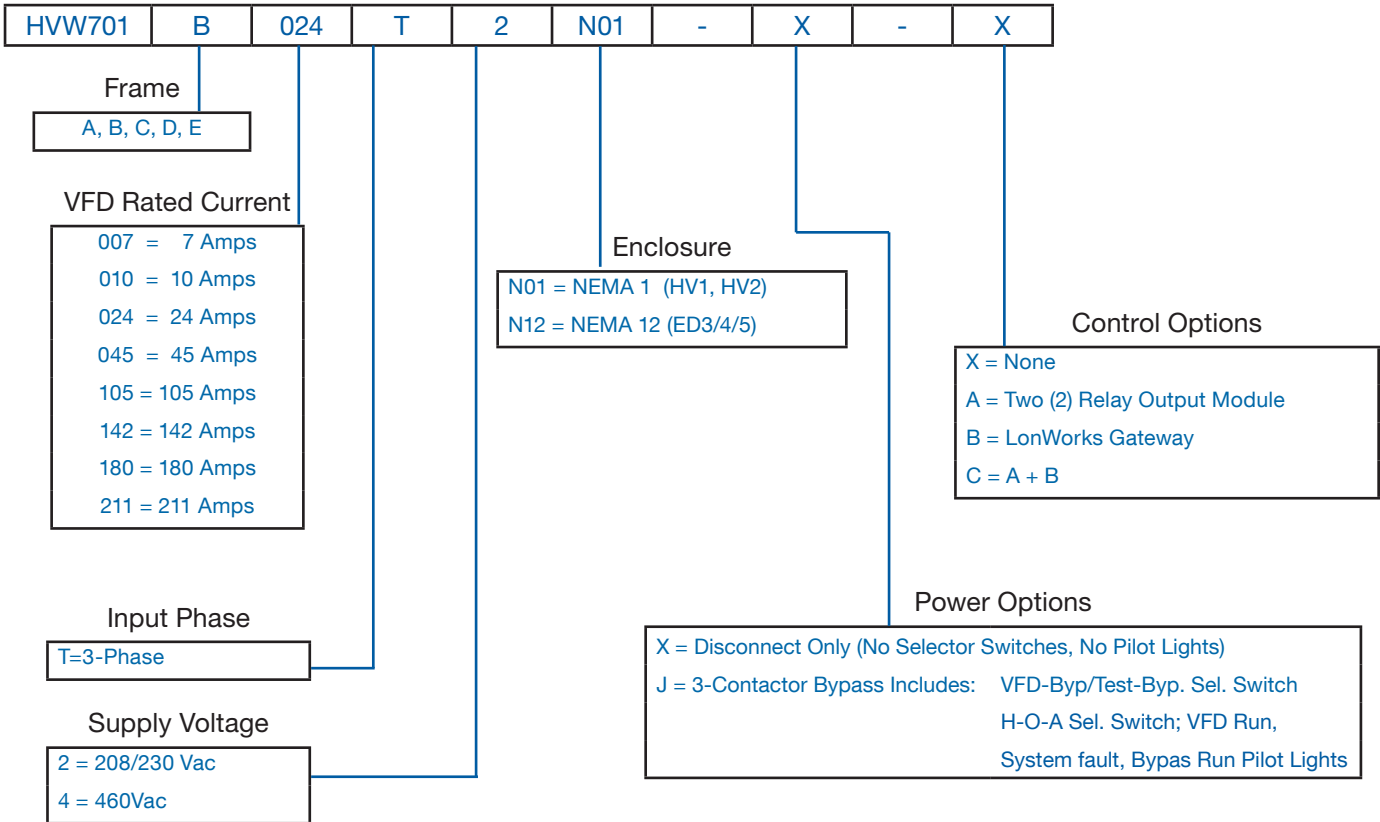

ENCLOSURE FRAME: HV1 & HV2

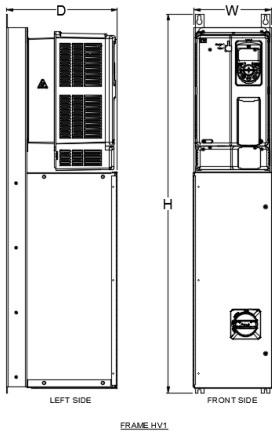

ENCLOSURE FRAME: ED3 & ED4

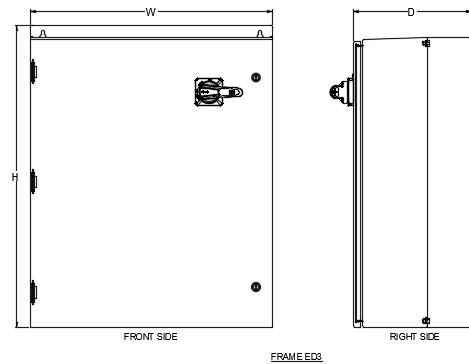

For pricing, contact your Local WEG distributor.

To locate a distributor, Please visit <https://www.weg.net/institutional/US/en/contact/where-to-buy>



WEG Electric Corp.
6655 Sugarloaf Pkwy.
Duluth, GA 30097
Phone: 1-800-ASK-4WEG
www.weg.net

