

TPDflex DC Converters

Frame C

Hardware Service Manual

Language: English

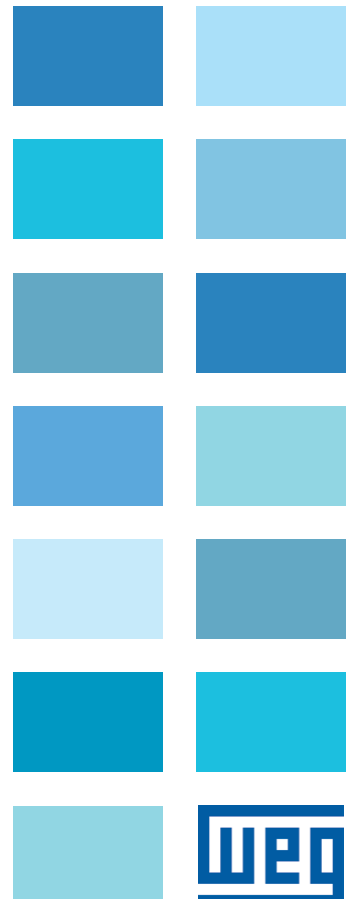

Important User Information

Read this document and any additional resources regarding installation, configuration, and operation of this equipment before installing, configuring, operating, or maintaining it. Users must follow installation and wiring instructions and comply with all applicable codes, laws, and standards.

All activities, including installation, adjustments, commissioning, use, assembly, disassembly, and maintenance, must be performed by properly trained personnel following applicable safety practices.

Using the equipment in ways not specified by the manufacturer may reduce its protective features.

Examples and diagrams are for illustrative purposes only and do not replace proper engineering judgment for actual installations.

No patent liability is assumed regarding the use of the information, circuits, equipment, or software described.

Reproduction of this manual, in whole or in part, is prohibited without written permission.

Notes in this manual highlight safety considerations where necessary.



WARNING Identifies information about practices or circumstances that can cause an explosion in a hazardous environment, which may lead to personal injury or death, property damage, or economic loss.



ATTENTION Identifies information about practices or circumstances that can lead to personal injury or death, property damage, or economic loss. Attentions help you identify a hazard, avoid a hazard, and recognize the consequence.

IMPORTANT Identifies information that is critical for successful application and understanding of the product.

These labels may also be on or inside the equipment to provide specific precautions.



SHOCK HAZARD Labels may be on or inside the equipment, for example, a drive or motor, to alert people that dangerous voltage may be present.



BURN HAZARD Labels may be on or inside the equipment, for example, a drive or motor, to alert people that surfaces may reach dangerous temperatures.



ARC FLASH HAZARD Labels may be on or inside the equipment, for example, a motor control center, to alert people to potential Arc Flash. Arc Flash will cause severe injury or death. Wear proper Personal Protective Equipment (PPE). Follow ALL Regulatory requirements for safe work practices and for Personal Protective Equipment (PPE).

The following icon may appear in the text of this document.



Identifies information that is useful and can help to make a process easier to do or easier to understand.

	Preface	
	Summary of Changes	5
	Chapter 1	
Before You Begin Testing Maintenance or Repairs	Introduction	7
	General Safety Precautions	7
	Hardware Description	8
	Commonly Used Tools	9
	Service Tools	9
	Software Tools	10
	Chapter 2	
Component Test Procedures	Introduction	11
	Save the Parameter Configuration	11
	Save to a HIM Set	11
	Download Parameters to an Offline Node File	12
	Visual Component Inspection	12
	Troubleshoot a Control Power Supply Failure	12
	Testing the Switching Power Supply and Pulse Transformer Boards	13
	Testing the Control and Field Board Connections	13
	Troubleshoot an AC Undervoltage Fault	15
	Troubleshoot an Armature Bridge Failure	17
	Troubleshoot a Field Current Loss Fault	20
	Low or Incorrect Field Current	21
	No Field Current	21
	Power Component Test Procedures	23
	Check the Armature SCR Modules	23
	Check the Pulse Transformer Board	27
	Check the Field SCR/Dual Diode Module	28
	Speed Feedback Device Tests	31
	Check the Encoder	31
	Check the DC Tachometer	31
	Check the Resolver Interface Board	31
Thermistors and Thermal Switches	33	
Relay Outputs	33	
Create a Fault Report	33	
What You Need When You Call Tech Support	33	
	Chapter 3	
Access Procedures	Remove Power from the Drive	35
	DPI / HIM Assembly Removal and Installation	36
	Remove the DPI/HIM Assembly	36
	Install the DPI / HIM Assembly	36
	Protective Cover Removal and Installation	36
Remove the Protective Covers from the Drive	36	

Install the Protective Covers on the Drive	38
Field Circuit Fuses Removal and Installation	38
Remove the Field Circuit Fuses	38
Install the Field Circuit Fuses	39
Communication Adapter and EMI Shield Removal and Installation	39
Remove the Communication Adapter and EMI Shield	39
Install the Communication Adapter and EMI Shield	41
Resolver Feedback and Interface Circuit Board Removal and Installation	41
Remove the Resolver Feedback and Interface Circuit Boards	41
Install the Resolver Feedback and Interface Circuit Boards	44
I/O Expansion Circuit Board Removal and Installation	44
Remove the I/O Expansion Circuit Board	44
Install the I/O Expansion Circuit Board	46
115V AC to 24V DC I/O Converter Circuit Board Removal and Installation	46
Remove the 115V AC to 24V DC I/O Converter Circuit Board	46
Install the 115V AC to 24V DC I/O Converter Circuit Board	47
Control Circuit Board Removal and Installation	47
Remove the Control Circuit Board	47
Install the Control Circuit Board	50
Control EMI Shield Removal and Closure	50
Move the Control EMI Shield	50
Install the Control EMI Shield	51
Switching Power Supply Circuit Board Fuse Removal and Installation	51
Remove the Fuses on the Switching Power Supply Circuit Board	51
Install the Fuses on the Switching Power Supply Circuit Board	52
Switching Power Supply Circuit Board Removal and Installation	52
Remove the Switching Power Supply Circuit Board	52
Install the Switching Power Supply Circuit Board	53
Pulse Transformer Circuit Board Removal and Installation	53
Remove the Pulse Transformer Circuit Board	53
Configure the Pulse Transformer Circuit Board	57
Install the Pulse Transformer Circuit Board	61
Field Power Circuit Board Removal and Installation	61
Remove the Field Power Circuit Board	61
Install the Field Power Circuit Board	62
Field SCR and Dual Diode Module Removal and Installation	62
Remove the Field SCR and Dual Diode Module	62
Install the Field SCR and Dual Diode Module	63
AC Line Snubber Circuit Board and Resistors Removal and Installation	64
Remove the AC Line Snubber Circuit Board and Resistors	64
Install the AC Line Snubber Circuit Board and Resistors	70
Transient Noise Filter Circuit Board Fuses Removal and Installation	70
Remove the Fuses on the Transient Noise Filter Circuit Board	70
Install the Fuses on the Transient Noise Filter Circuit Board	71
Transient Noise Filter Circuit Board Removal and Installation	71
Remove the Transient Noise Filter Circuit Board	71
Install the Transient Noise Filter Circuit Board	75
Power Supply Filter Circuit Board Removal and Installation	75
Remove the Power Supply Filter Circuit Board	75
Install the Power Supply Filter Circuit Board	77

	Armature Leg Fuses Removal and Installation	77
	Remove the Armature Leg Fuses	77
	Install the Armature Leg Fuses	80
	SCR Modules Removal and Installation.....	81
	Remove the SCR Modules.....	81
	Install the SCR Modules	88
	AC Current Transducers Removal and Installation.....	88
	Remove the AC Current Transducers	88
	Install the AC Current Transducers.....	94
	Bimetal Thermostats Removal and Installation	94
	Remove the Bimetal Thermostats.....	94
	Install the Bimetal Thermostats	101
	Cooling Fans Removal and Installation	102
	Remove the Cooling Fans.....	102
	Install the Cooling Fans	104
	 Chapter 4	
Start Up After Repair	Test With the Motor, Without a Mechanical Load	105
	 Appendix A	
Schematics	List of Schematic Diagrams	107
	 Appendix B	
	 Board Layouts and Connections B	
	List of Board Layouts	117
	Pulse Transformer Board.....	117
	Switching Power Supply Board	121
	Control Board	122
	Field Power Board.....	125
	 Appendix C	
Flow Charts	List of Flow Charts	127
	Control Power Supply Failure	128
	Field Current Loss Failure	129
	No Field Current	129
	Low or Incorrect Field Current	130
	 Index	135
	Do you need help?	139

Notes

This manual contains component test and hardware replacement information for TPDflex DC Converter frame C drives, 150...500 Hp (112...373 kW).

This manual is intended for qualified service personnel responsible for troubleshooting and repairing TPDflex DC Converters. You should have previous experience with, and basic understanding of, electrical terminology, procedures, required troubleshooting equipment, equipment protection procedures and methods, and safety precautions.

It is highly recommended that you obtain a copy of the TPDflex DC Converters User Manual, publication 1S7TFLEXUM0, which contains fault/alarm and programming information to assist you in troubleshooting drive errors and determining if repairs are necessary.

Please contact your local Allen-Bradley distributor or the Rockwell Automation sales office for information about related publications and how to obtain manuals.

Summary of Changes

This manual contains new and updated information.

Topic	Page
Added Series B Control Board Testpoints - Upper Left	17
Added Series B Control Board Testpoints - Upper Right	17
Added Combined AC Line Input Signal Testpoints Series B	19
Added Series B figure for Good SCR Gate Pulse and Armature Current Signals	22
Added Series B Good SCR Armature Voltage and Motor Current Signal	23
Added Series B Open Thyristor	24
Added Three Series B Control Circuit Boards Replacement	52, 53, 54
Added Control Board Layout Series B	126
Added table for Series B Control Board to Field Board Connections	127, 128

Notes

Before You Begin Testing Maintenance or Repairs

Introduction

This chapter provides information you should know before you begin tests, maintenance or repairs on drive components.

General Safety Precautions

Read the following precautions before you begin testing components, performing maintenance or repairing the drive.



ATTENTION Only qualified personnel familiar with DC drives and associated machinery should plan or implement the installation, start-up and subsequent maintenance of the system. Failure to comply may result in personal injury and/or equipment damage.



ATTENTION This drive contains **ESD** (Electrostatic Discharge) sensitive parts and assemblies. Static control precautions are required when installing, testing, servicing or repairing this assembly. Component damage may result if ESD control procedures are not followed. If you are not familiar with static control procedures, reference A-B publication 8000-4.5.2, "Guarding Against Electrostatic Damage" or any other applicable ESD protection handbook.



ATTENTION Severe injury or death can result from electrical shock, burn, or unintended actuation of controlled equipment. Hazardous voltages may exist in the drive enclosure even with the circuit breaker in the off position. Recommended practice is to disconnect and lock out control equipment from power sources. If it is necessary to work in the vicinity of energized equipment, the safety related work practices of NFPA 70E, Electrical Safety Requirements for Employee Workplaces, must be followed. **DO NOT** work alone on energized equipment.



ATTENTION Potentially fatal voltages may result from improper usage of an oscilloscope and other test equipment. The oscilloscope chassis may be at a potentially fatal voltage if not properly grounded. If an oscilloscope is used to measure high voltage waveforms, use only a dual channel oscilloscope in the differential mode with X 100 probes. It is recommended that the oscilloscope be used in the A minus B Quasi-differential mode with the oscilloscope chassis correctly grounded to an earth ground.



ATTENTION Remove power before making or breaking cable connections. When you remove or insert a cable connector with power applied, an electrical arc may occur. An electrical arc can cause personal injury or property damage by:

- sending an erroneous signal to your system's field devices, causing unintended machine motion
- causing an explosion in a hazardous environment

Electrical arcing causes excessive wear to contacts on both the module and its mating connector. Worn contacts may create electrical resistance.



ATTENTION **HOT** surfaces can cause severe burns. **Do not** touch the heatsink surface during operation of the drive. After disconnecting power allow time for cooling.

Hardware Description

The TPDflex DC Converter contains a power structure that has an armature and field supply. The armature supply consists of a three-phase, full wave rectified, dual bridge, capable of two or four quadrant output. The field supply consists of single phase, full wave rectified bridge. Also associated with the power structure are incoming line protection devices and contactor and dynamic brake control circuits.

Verify that you are working on a frame C drive by checking the data nameplate located on the side of the drive. The frame size is printed just above the serial number in the lower right corner of the label.

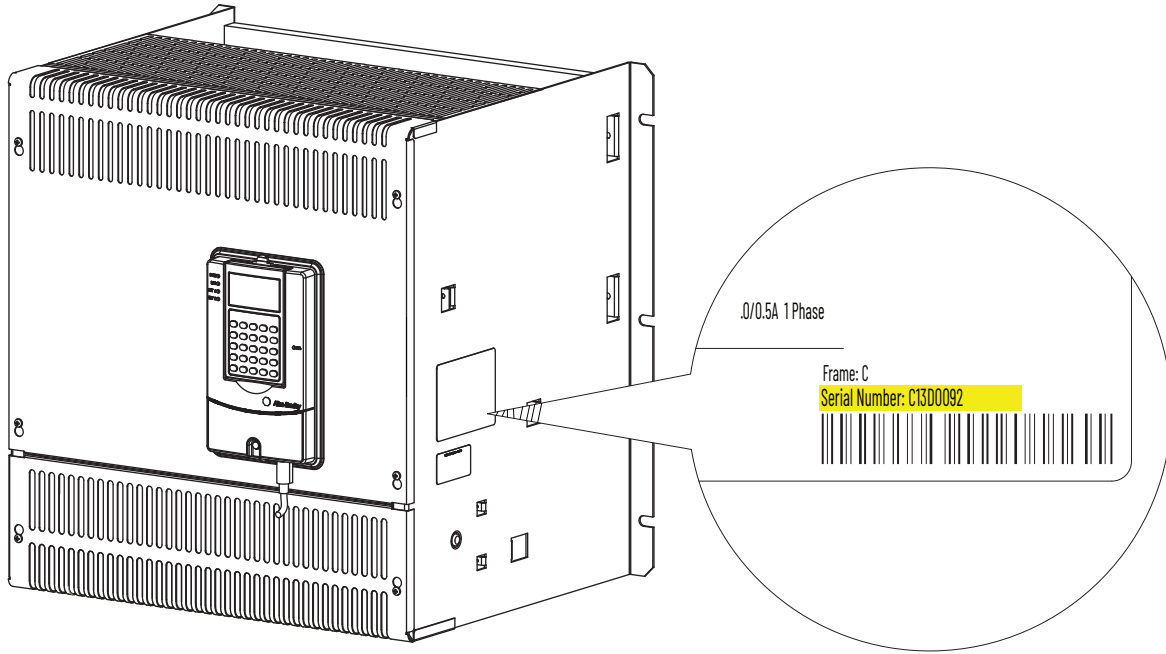

Commonly Used Tools

Service Tools

This list of basic service tools which will cover needs of tools for repair and maintenance measurements.

Item	Details
Digital Multimeter	Digital multimeter, capable of ac and dc voltage, continuity, resistance and forward diode bias tests. Fluke model 87 III or equivalent (recommended).
Oscilloscope	Portable, digitizing, dual channel scope, with isolation
Current clamp	3x drive rated armature current output
Soldering station	Soldering / de soldering
Torque wrench	1...12 N•m
Torque wrench	6...50 N•m
box wrench	7 mm, 8 mm, 10 mm, 13 mm, 17 mm, 19 mm, 22 mm
socket extension	230 mm
Wrench	7 mm, 8 mm, 10 mm, 13 mm, 17 mm, 19 mm, 22 mm
Wire cutter	
Nose pliers	
Crimping tools	For cable terminals 1.5...240
Angle wrench	
Screw drivers	
Flat nose	7x2 mm
Hexalobular	T15, T20, T25
Phillips®	#1, 2, 3
Hexagonal wrench	#4, 5, 6
ESD-protected place of work	Working surface, floor covering, seat and ground connections
ESD-protective clothing	Wrist wrap, shoes, overall clothing (coat)

Phillips® is a registered trademark of Phillips Screw Company.

Software Tools

DriveTools™ SP, DriveExecutive, DriveExplorer™ and DriveObserver™ are software tools for uploading, downloading and monitoring system parameters.

Notes

Component Test Procedures

Introduction

This chapter provides general procedures for inspecting and testing the major components of the drive and includes recommendations for repairs. Due to the technical nature of this product and the variety of possible applications, not all possible fault conditions and troubleshooting solutions can be described in this manual.

Topic	Page
Save the Parameter Configuration	13
Visual Component Inspection	14
Troubleshoot a Control Power Supply Failure	14
Troubleshoot an AC Undervoltage Fault	19
Troubleshoot an Armature Bridge Failure	21
Troubleshoot a Field Current Loss Fault	24
Power Component Test Procedures	27
Speed Feedback Device Tests	35
Thermistors and Thermal Switches	37
Relay Outputs	37
Create a Fault Report	37
What You Need When You Call Tech Support	37

IMPORTANT Using the diagnostic tests in this chapter should only be performed by qualified personnel and only when other corrective actions have failed. All tests assume that the control board connections have been properly made.





For common drive symptoms and corrective actions and fault troubleshooting information, see Chapter 4 “Troubleshooting” in the TPDflex DC Converter User Manual, publication 1S7TFLEXUM0.





Save the Parameter Configuration

It is recommended that you save the drive and communication adapter parameter configuration to a HIM Set or by up loading the drive and adapter parameters to an offline node file using DriveExecutive™ before performing any service or testing on the drive. HIM sets are files stored in permanent nonvolatile HIM memory.

Save to a HIM Set

Complete these steps to save the drive and adapter parameters to a HIM set.

1. On the HIM, access the **Memory Storage** menu.
2. Select the **HIM CopyCat** menu and press .
3. Select **Device -> IM** and press .
4. Do one of the following:
 - If there are no existing HIM Sets, enter a name using the  and  buttons to select the desired characters and press .

- If there is an existing HIM Set, press  to overwrite it, or select **No** using the  button and use the  and  buttons to select the desired characters. Then press .

The HIM Set will be saved to nonvolatile memory.

Download Parameters to an Offline Node File

You can save all drive and adapter parameters in the drive to an offline database file on your computer using DriveExecutive. An offline node file (*.dno) contains all information about the node, including the necessary databases.

- From the **Drive** menu, select **Load from Drive** or click the upload button  on the toolbar.
- Click **Yes** to confirm the operation, which cannot be undone.
- If you are not connected to a drive, the Connect to Drive dialog displays. Select the drive to which you want to connect and click **OK**.
- A dialog displays the status of the upload operation. Click **Cancel** to cancel the operation.

Visual Component Inspection

Visually inspect the drive circuit boards and power components before energizing the drive for any of the component test procedures.

- Read the [General Safety Precautions on page 9](#).
- Remove power from the drive. See [Remove Power from the Drive on page 39](#).
- Remove the protective covers and lower the control EMI shield when necessary. See [Remove the Protective Covers from the Drive on page 41](#) and [Move the Control EMI Shield on page 54](#).
- Check components for burn marks, breakage or foil delamination on all circuit boards. Replace any of these components without further testing if they show evidence of burn marks, breakage or foil delamination.

Troubleshoot a Control Power Supply Failure

If a drive Power Failure fault (F3) has occurred and the drive is inoperable via the HIM or other means of control, complete the steps below to determine where the control power failure has occurred.

- Read the [General Safety Precautions on page 9](#).
- Remove the protective covers from the drive. See [Remove the Protective Covers from the Drive on page 41](#).
- Measure the signal voltage at the testpoints on the control board as indicated in the following table.

Signal Voltage at the testpoints

Name	Testpoint	For Testpoint Location See	Associated Connector Pin	Description
+ 5V	XY5	Figure 1 on page 17	XA-1 / XA-3 / XA-5	+5V digital supply
GNDD	XY6	Figure 1 on page 17	XA-2 / XA-4 / XA-6	+5V digital supply ground
GNDD	XY7	Figure 2 on page 17	XA-2 / XA-4 / XA-6	+5V digital supply ground
+15V	XY12	Figure 1 on page 17	XA-9 / XA-10	+15V analog supply
GNDA	XY10	Figure 1 on page 17	XA-11 / XA-12	15V analog supply ground
-15 V	XY11	Figure 1 on page 17	XA-13 / XA-14	-15V analog supply
+24V	XY8	Figure 1 on page 17	XA-16	+24V terminal block
GNDV	XY9	Figure 1 on page 17	XA-15	+24V terminal block ground

Signal Voltage at the testpoints

Name	Testpoint	For Testpoint Location See	Associated Connector Pin	Description
+5VEXP	+5VEXP	Figure 2 on page 17	XP3-1 / XP3-2 / XP3-3	+5V for DPI expansion
+12VEXP	+12VEXP	Figure 2 on page 17	XP3-4 / XP3-5	+12V for DPI expansion
OVEXP	OVEXP	Figure 2 on page 17	XP3-7 / XP3-8 / XP3-9	DPI expansion ground



For a flow chart version of the steps that follow, see [Control Power Supply Failure on page 132](#).

4. If any of the signals in the table above is incorrect or missing, verify that either 115 VAC or 230 VAC voltage is present at terminals U2 and V2 (control circuit power input).
 - If the voltage is present and correct, continue with step 5 below.
 - If the voltage is incorrect or missing, remove control power and verify the wiring and power source to U2, V2 and correct any problems. Test the voltage level again to verify that it is correct. If the voltage is correct, but the drive is still inoperable, continue with step 5 below.
5. Remove AC control power from terminals U2 and V2 and remove and test the fuses (F1 and F2) on the switching power supply board. See [Switching Power Supply Circuit Board Fuse Removal and Installation on page 56](#) for fuse location.
 - If the fuse is blown, continue with step 6 below.
 - If the fuse is not blown, replace the switching power supply board.
6. Replace the fuse on the switching power supply board. See [Switching Power Supply Circuit Board Fuse Removal and Installation on page 56](#).
7. Disconnect the cable at connector XA on the control board. See [Figure 32 on page 126](#) for location of connector XA.
8. Apply AC control power to the drive.
 - If the fuse blows, continue with [Testing the Switching Power Supply and Pulse Transformer Boards](#) below.
 - If the fuse does not blow, continue with [Testing the Control and Field Board Connections on page 15](#).

Testing the Switching Power Supply and Pulse Transformer Boards

1. Remove power from the drive.
2. Replace the fuses on the switching power supply board. See [Switching Power Supply Circuit Board Fuse Removal and Installation on page 56](#).
3. Remove the switching power supply board from the drive. See [Switching Power Supply Circuit Board Removal and Installation on page 57](#).
4. Reapply power to the switching power supply board only.
 - If the power supply fuses do not blow, continue with [step 5](#).
 - If the power supply fuses blow, replace the switching power supply board.
5. Remove all incoming AC voltage from the drive.
6. Check all external wiring connected to the pulse transformer board, including the motor PTC if used, for a possible short circuit condition. Repair any short circuit conditions if found.
7. If no short circuit conditions exist, replace the pulse transformer board.

Testing the Control and Field Board Connections

1. Using an ohmmeter, check all input and output wiring on terminals 1..40 on terminal blocks TB1 and TB2 on the control board for a possible short circuit condition. Repair any short circuit conditions if found.

2. If an encoder and/or tachometer is used, use an ohmmeter to check all wiring on the respective terminals for a possible short circuit condition. Repair any short circuit conditions if found.
3. Remove the cables from connector XR and XFCD on the control board and use an ohmmeter to check between all voltage test points and common on the control board for possible short circuit conditions. The ohmmeter measurements should be greater than 200 k Ω . If any low resistance measurements are found, replace the control board.
4. Using an ohmmeter, measure between pins 1 and 2 and pins 3 and 2 on the XFCD cable connector. The resistance measurement for both tests should be greater than 200 k Ω . If a lower resistance value is measured, replace field board.

Figure 1 - Control Board Testpoints - Upper Left

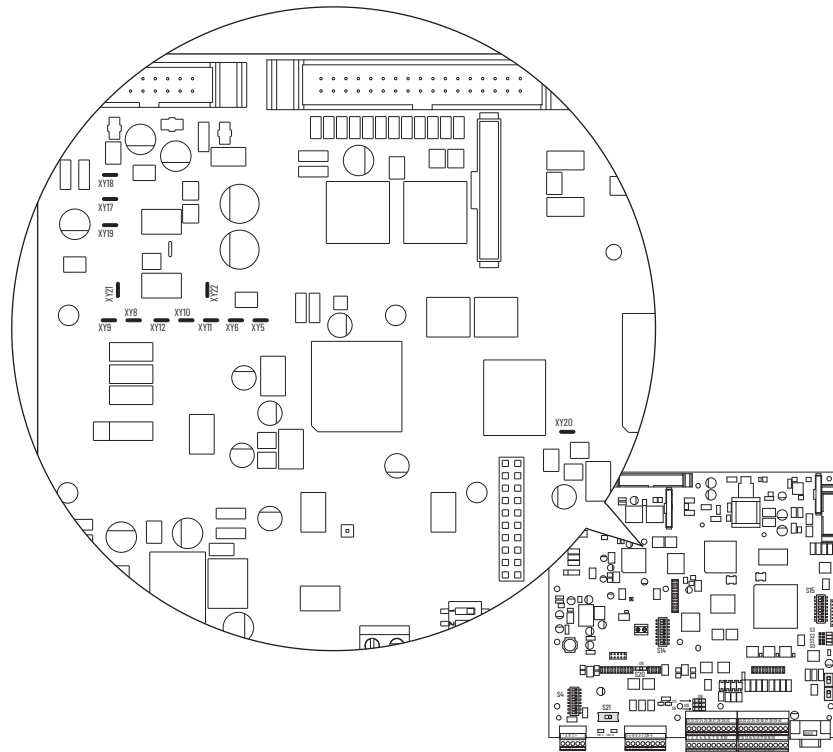

Series A

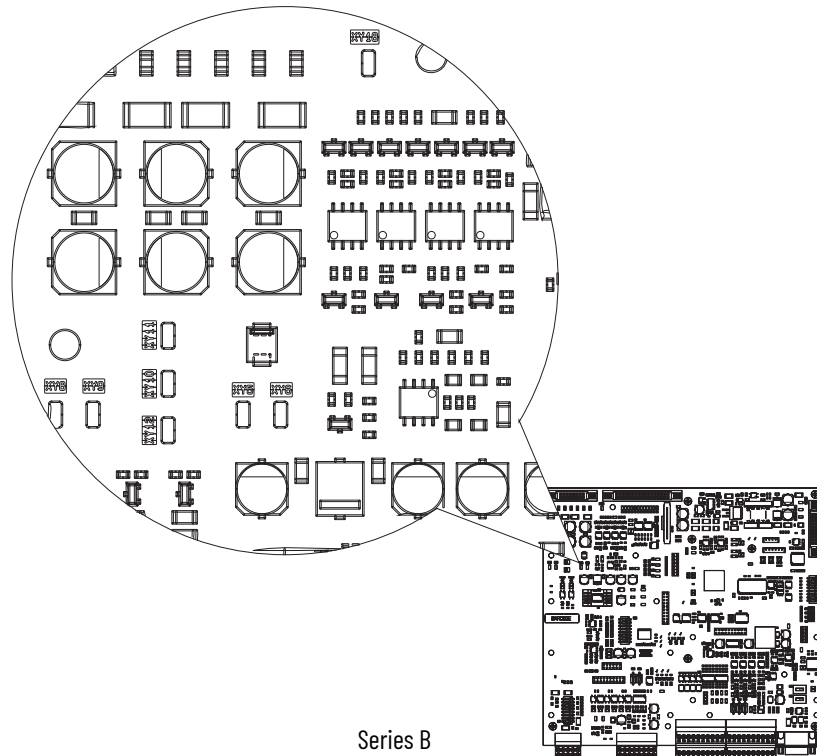

Series B

Figure 2 - Control Board Testpoints - Upper Right

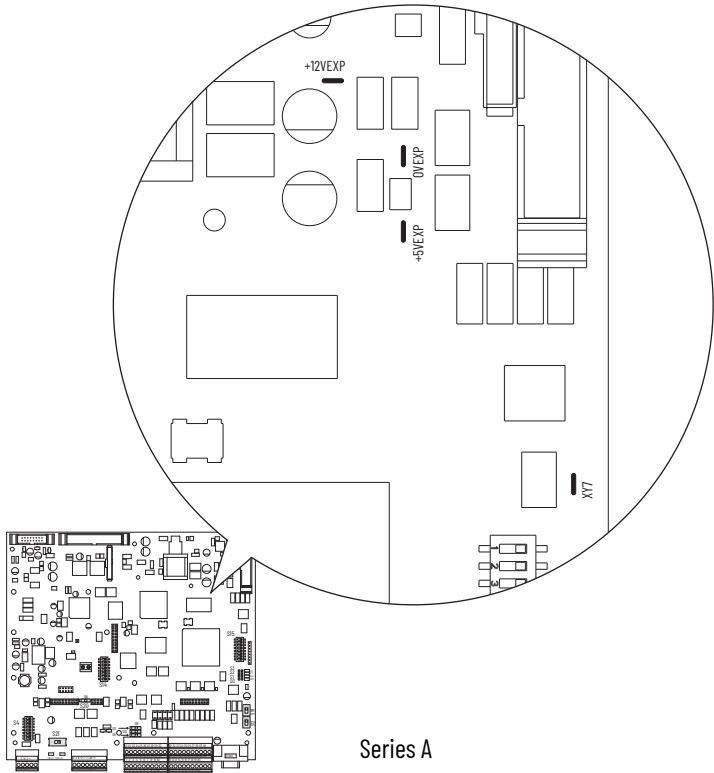

Series A

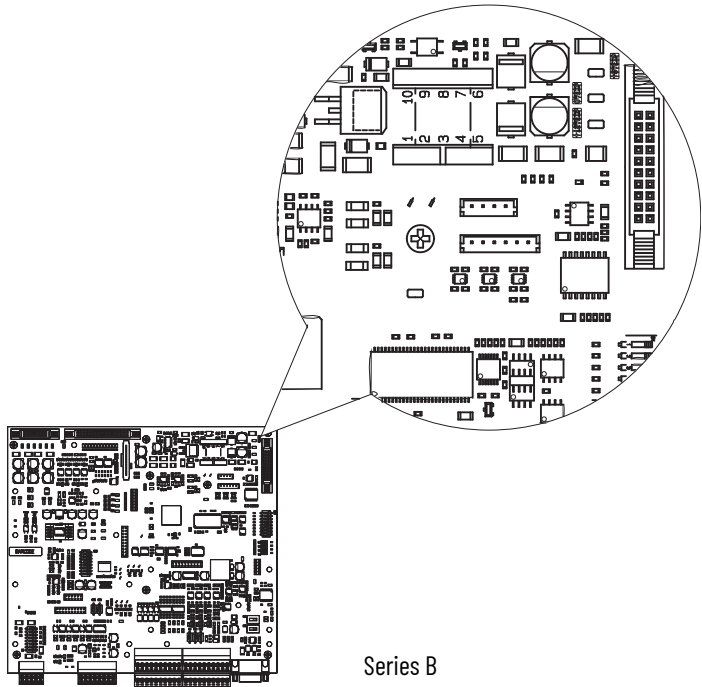

Series B

Troubleshoot an AC UnderVoltage Fault

If the drive faults with an AC Undervoltage Fault (F4), or parameter 466 [AC Line Voltage] does not equal the expected incoming AC line voltage, measure the AC line input signals as directed in the steps below.

1. Read the [General Safety Precautions on page 9](#).
2. Remove the protective covers from the drive. See [Protective Cover Removal and Installation on page 41](#).

3. Using a voltmeter, measure the voltage at terminals U, V, and W of the drive.

Note: If an AC input contactor is used, the voltage must be measured on both the input and output sides of the contactor.

If any of the voltage measurements is incorrect or missing, remove incoming AC power and verify the wiring to the drive and the power supply source and correct any problems.

4. Using a voltmeter, measure the combined voltages of the AC lines on the following testpoints on the control board (all waveforms have a 2.5V offset). See [Figure 1 on page 17](#) and [Figure 2 on page 17](#) for location of the testpoints. Also, see [Figure 17 on page 113](#) for a schematic diagram.

Table 1 - Combined AC Line Input Signal Testpoints Series A

Incoming AC Line Voltage	Phases	Measure From Testpoint	To Testpoint	Peak to Peak Measurement	RMS Measurement
240V AC	V and U	XY22	... XY18	1.42V AC	0.500V
	V and W	XY21	... XY18		
480V AC	V and U	XY22	... XY18	2.95V AC	1.040V
	V and W	XY21	... XY18		
575V AC	V and U	XY22	... XY18	2.85V AC	1.007V
	V and W	XY21	... XY18		
690V AC	V and U	XY22	... XY18	3.45V AC	1.220V
	V and W	XY21	... XY18		

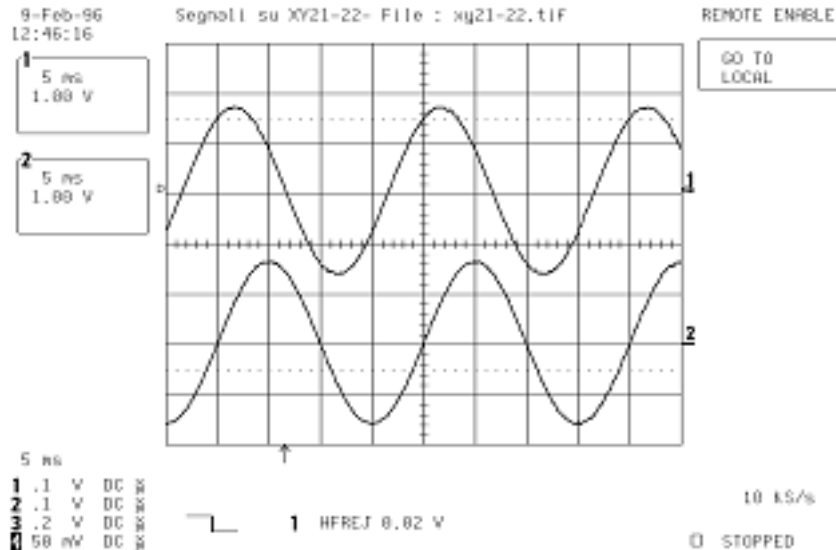
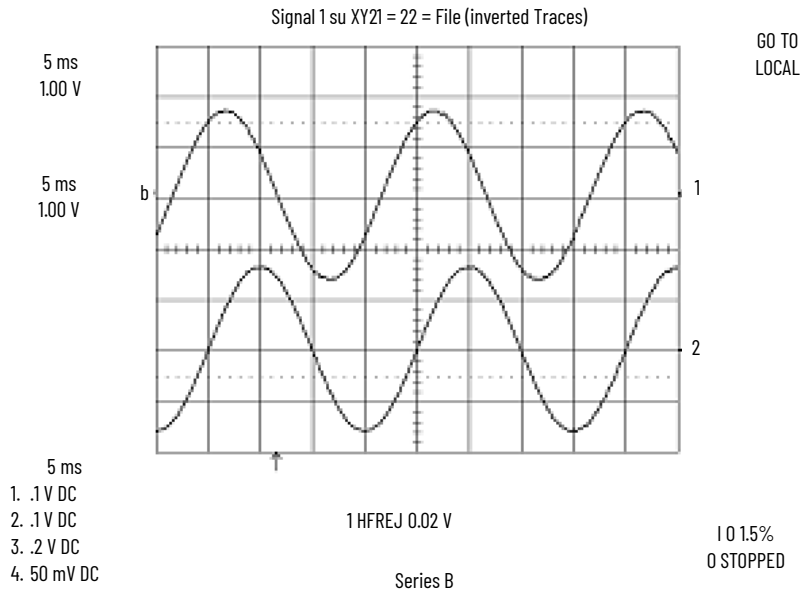

Table 2 - Combined AC Line Input Signal Testpoints Series B

Incoming AC Line Voltage	Phases	Measure from Testpoint	To Testpoint	Peak to Peak Measurement	RMS Measurement
240V AC	V and U	XY22	... XY18	0.93V AC	0.330V
	V and W	XY21	... XY18		
480V AC	V and U	XY22	... XY18	1.86V AC	0.660V
	V and W	XY21	... XY18		

Incoming AC Line Voltage	Phases	Measure from Testpoint		To Testpoint	Peak to Peak Measurement	RMS Measurement
575V AC	V and U	XY22	...	XY18	1.79V AC	0.630V
	V and W	XY21	...	XY18		
690V AC	V and U	XY22	...	XY18	1.80V AC	0.640V
	V and W	XY21	...	XY18		



- If any of the voltage measurements above are incorrect or missing, continue with [step 5](#).
 - If the voltage measurements above are correct but the value of parameter 466 [AC Line Voltage] is incorrect, replace the control board.
5. Remove the ribbon cable connected to XR on the control board and pulse transformer board and test the continuity of the cable using the measurements in [Table 26 on page 124](#).
- If the measurements on the XR cable are correct, replace the pulse transformer board.

Troubleshoot an Armature Bridge Failure

If the drive is running unstable or faults with an Overcurrent Fault (F13) an armature bridge failure may have occurred. All of the signals going to and coming from the SCR bridges are transmitted via the ribbon cable connected to XR on the control board and can be measured at these points. See [Figure 32 on page 126](#) for location of the XR connector on the control board.

IMPORTANT These checks cannot be completed with an AC contractor in use.

1. Read the [General Safety Precautions on page 9](#).
2. Remove the protective covers from the drive. See [Protective Cover Removal and Installation on page 41](#).
3. If using a DC output contactor, disconnect the cable from XR on the control board and measure the signal for each SCR gate as indicated in the table below:

Signal Name	R Cable Pin	ate		Note
		MP	MN	
IT1	27	G1	G04	
IT2	29	G2	G05	
IT3	31	G3	G06	
IT4	21	G4	G01	
IT5	23	G5	G02	
IT6	25	G6	G03	
MN	33	-	-	Negative bridge MN - active when high (+5V)
MP	34	-	-	Positive bridge MP - active when high (+5V)

[Figure 3](#), [Figure 5](#), and [Figure 7](#) below are examples representing gate pulse, current and voltage signal measurements taken on an SCR. In the figures below:

- The current signal is taken on the testpoint XY17 (+2.5V offset; +0.6V=Drive size current).
- The voltage signal is taken on the testpoint XY19 (+2.5V offset, inverted traces).
- The ground signal is taken on either testpoint XY10 or XY18.

Figure 3 - Good SCR Gate Pulse and Armature Current Signals Example series A

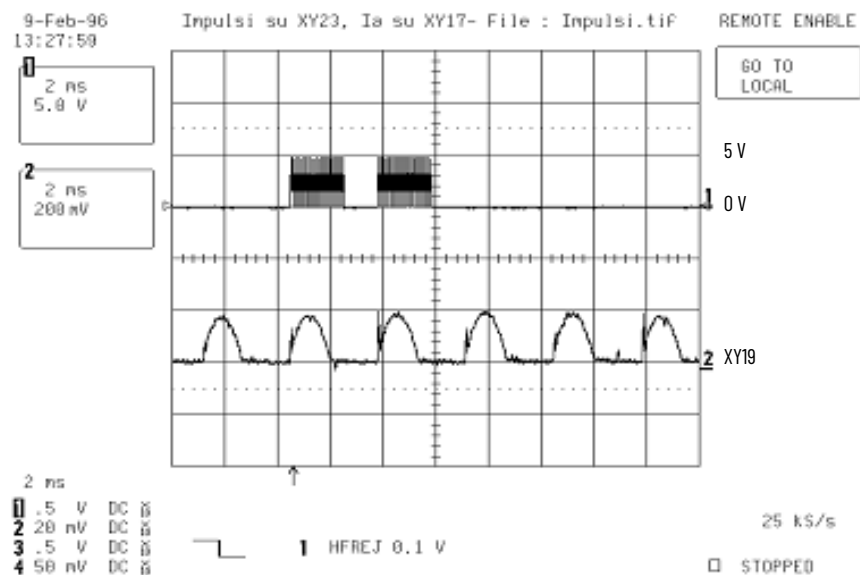

Figure 4 - Good SCR Gate Pulse and Armature Current Signals Series B Example

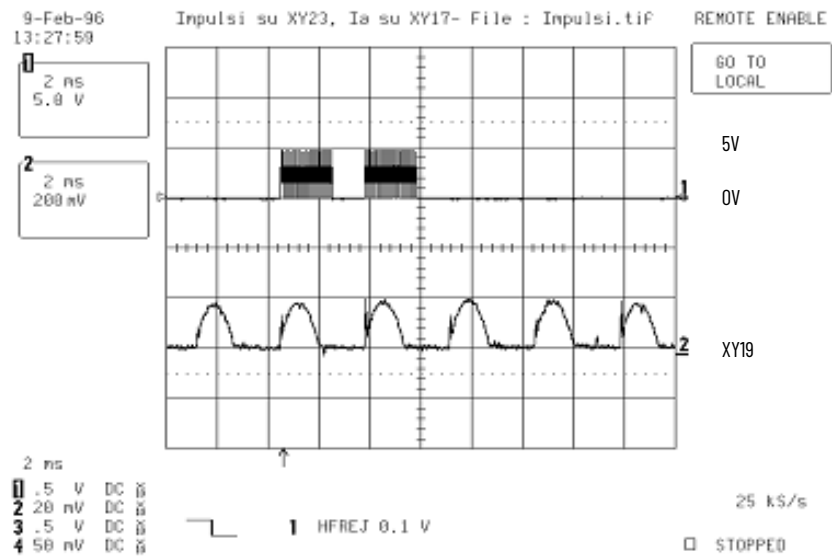

Figure 5 - Good SCR Armature Voltage and Motor Current Signal Series A Example

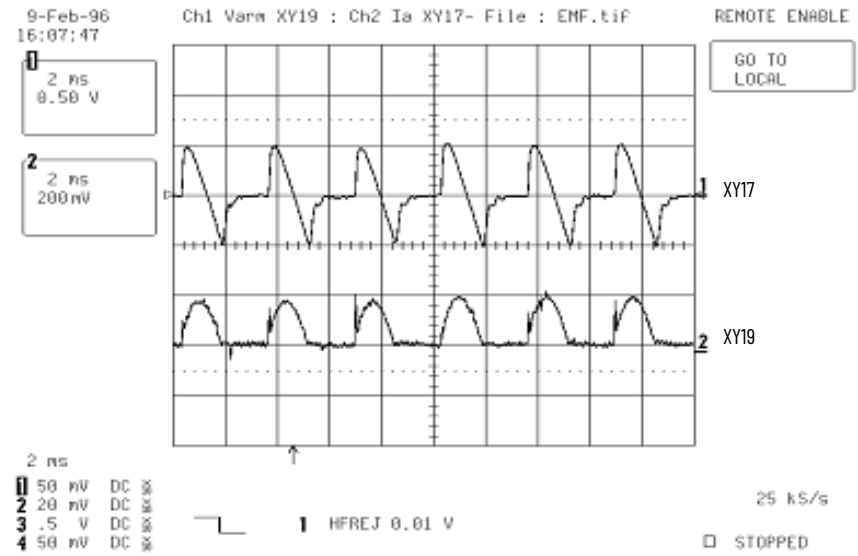
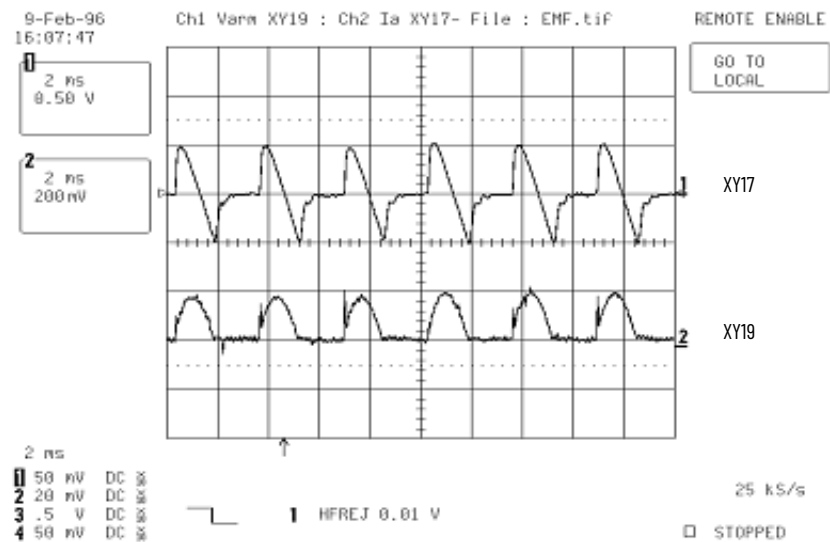
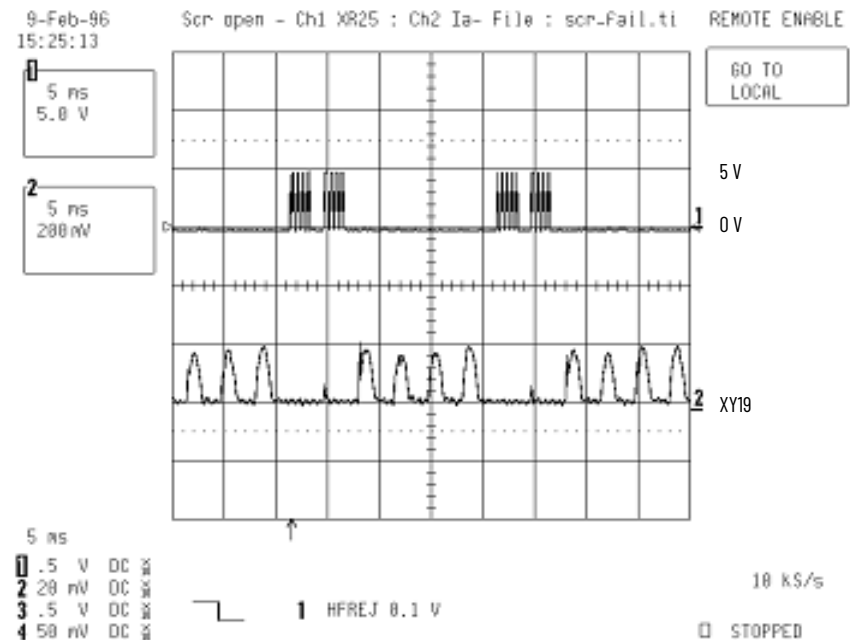

Figure 6 - Good SCR Armature Voltage and Motor Current Signal Series B Example



A malfunctioning thyristor is connected to the relative gate. For example, if the tested signal is at XR25 and the positive bridge is active (MP high) from [Figure 7](#) you can deduce that SCR connected to gate G6 is open.

Figure 7 - Open Thyristor Series A Example



[Figure 4 on page 22](#), [Figure 6 on page 23](#), and [Figure 8 on page 24](#) are examples of gate pulse, current, and voltage signal measurements taken on an SCR. In these figures:

- The current signal is taken on the testpoint XY17 (+2.53V offset; -0.6V=Drive size current).
- The voltage signal is taken on the testpoint XY19 (+1.5V offset, inverted traces).
- The ground signal is taken on either testpoint XY10 or XY18.

Figure 8 - Open Thyristor Series B Example

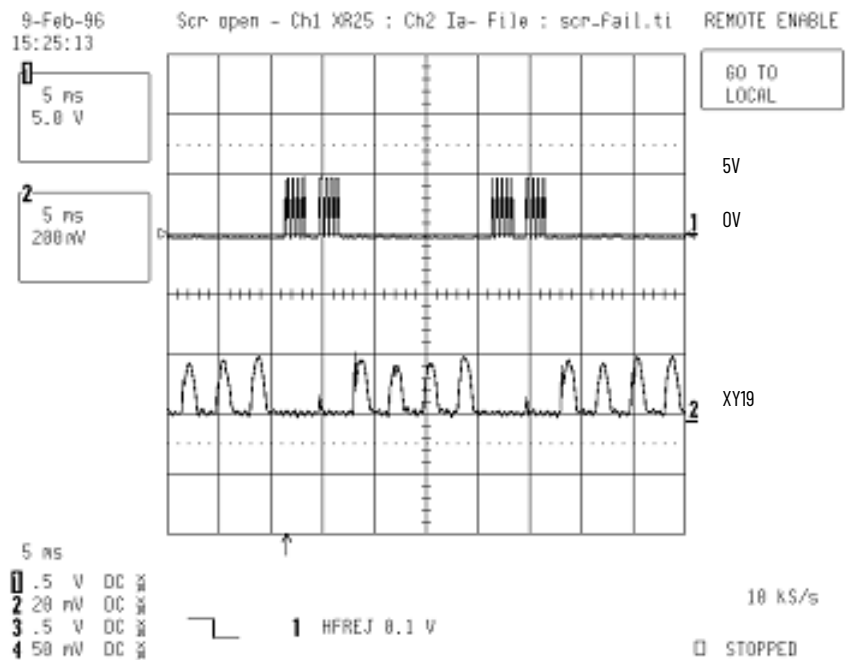

Troubleshoot a Field Current Loss Fault

If the drive faults with a “Field Current Loss” fault (F6) and there is low or incorrect field current present at the motor, as seen in parameter 351 [Field Current], complete the steps in [Low or Incorrect Field Current](#) below. If the drive faults with a “Field Current Loss” fault (F6) and there is no field current present at the motor, as seen in parameter 351 [Field Current], complete the steps in [No Field Current on page 25](#).

Low or Incorrect Field Current

Note: For a flow chart version of these steps, see [Low or Incorrect Field Current on page 134](#).

1. Read the [General Safety Precautions on page 9](#).
2. Verify the actual value of parameter 351 [Field Current] by measuring the DC motor field current using a DC clamp.
3. Verify that the drive rated field bridge current is set correctly in parameter 374 [Drv Fld Brdg Cur] and DIP switch S14 is configured to correctly (according to the instructions in the TPDFlex DC Converters User Manual, publication 1S7TFLEUM0) and make any necessary corrections. See [Control Board on page 126](#) for DIP switch location.
4. Verify that the value of parameter 280 [Nom Mtr Fld Amps] matches the rated field current value on motor nameplate and make any necessary corrections.
5. Remove the protective covers from the drive. See [Protective Cover Removal and Installation on page 41](#).
6. Measure the field current signal on the green LA-LB terminal located on the control board: LA is the ground and LB is field current signal. The measured value of the field current at LA-LB should be equal to the value of parameter 374 [Drv Fld Brdg Cur]. If these values are equivalent, the voltage across these terminals should be 1.66 VDC.

Note: For lower field current values, the voltage will be proportional.

For example, if the field is set up for 2 A and the motor is rated for 1.5 A, the measurement at LA-LB will be 1.245 VDC ($1.5 / x = 2 / 1.66$).

- If the voltage measurement is incorrect, continue with step 7 below.
- If the voltage measurement is correct, but the “Field Current Loss” fault still exists, replace the control board.

- Using an ohmmeter, measure the resistance across terminals LA-LB to verify that the value equals the equivalent resistance as indicated in the table below (set with DIP switch S14 on the control board).

Switch ohms		168 5	333 3	182	36 4	845	1668	3333		Equivalent Resistance
Field Current Scale	Field Supply	S14 1	S14 2	S14 3	S14 4	S14 5	S14 6	S14 7	S14 8	Ohms
1 A	10 A	OFF	OFF	OFF	OFF	OFF	ON	Not used (OFF)		1668
2 A		OFF	OFF	OFF	OFF	ON	OFF		845	
3 A		OFF	OFF	OFF	OFF	ON	ON		560.9	
5 A		OFF	ON	OFF	OFF	OFF	OFF		333.3	
10 A		ON	OFF	OFF	OFF	OFF	OFF		168.5	
13 A	14 A	ON	OFF	OFF	OFF	ON	ON		129.6	
17 A	20 A	OFF	ON	ON	OFF	ON	ON		97.3	
20 A		ON	OFF	ON	OFF	OFF	ON		83.1	

- If the resistance measurement is incorrect, replace the field board.

No Field Current

Note: For a flow chart version of these steps, see [No Field Current on page 133](#).

- Read the [General Safety Precautions on page 9](#).
- Remove the protective covers from the drive. See [Protective Cover Removal and Installation on page 41](#).
- Verify that the correct AC voltage is present at terminals U1 and V1 at the top of the field fuse holder mounted on the control panel. See [Figure 19 on page 115](#) for a schematic diagram.
 - If the voltage is correct, continue with step 4 below.
 - If the voltage is incorrect or missing, remove power from the drive and verify the wiring to the drive and the power supply source and correct any problems. Test the voltage level again to verify that it is correct. If the voltage is correct, but the fault persists or parameter 351 [Field Current] is incorrect, continue with step 4 below.
- Remove AC power to the drive and check the fuses at FU1 and FV1. See [Remove Power from the Drive on page 39](#).
 - If the fuses are blown, complete the steps in [Test Field Wiring and Voltage Signals on page 25](#).
 - If the fuses are not blown, complete the steps in [Test Field Control Signals on page 25](#).

Test Field Wiring and Voltage Signals

- Test the resistance of the motor field wiring and motor field for possible short circuits.
 - If there are no short circuits, continue with [step 2](#).
 - If a short circuit exists, correct any problems.
- Check the field SCR/dual diode module for a short circuit condition. See [Check the Field SCR/Dual Diode Module on page 32](#).
 - If there are no short circuits, continue with [step 3](#).
 - If a short circuit exists, replace the field SCR/dual diode module.
- Replace the field fuses at FU1 and FV1 and apply power to the drive.
- If the field fuses blow, replace the field board.

Test Field Control Signals

- Disconnect the cable from connector XR on the control board and measure the U1-V1 voltage synchronization signal at pin 11 on the cable. See [Figure 32 on page 126](#) for location of the XR connector on the control board.

This signal is a square wave signal with a 90° lag phase displacement compared to the AC voltage signal.

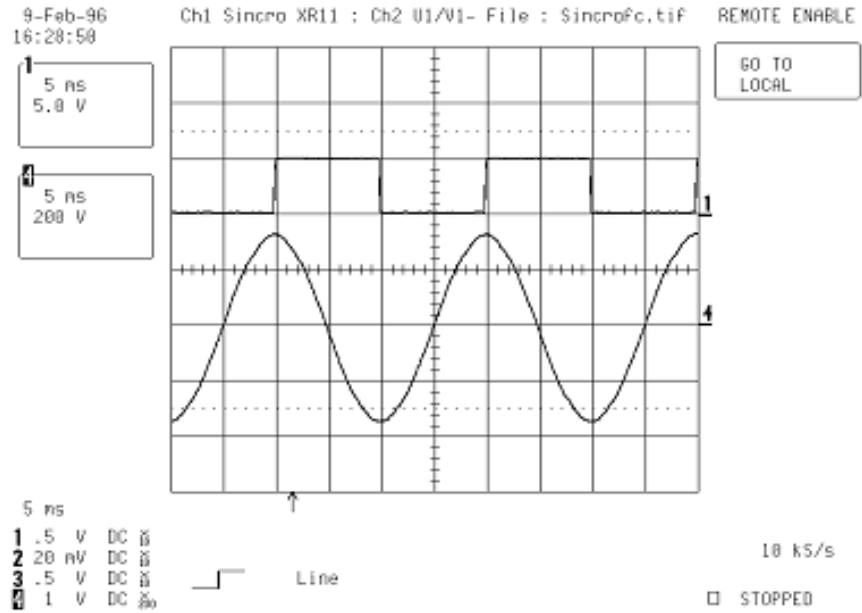

2. Measure the gate signals at pins XR-1 and XR-2 on the cable. The figure below displays the following signals from top to bottom:

Channel	Signal
1	U1-V1 Sync
4	Ie - LEM current feedback signal taken on LA-LB terminal
2	ITF1 pulse
3	ITF2 pulse

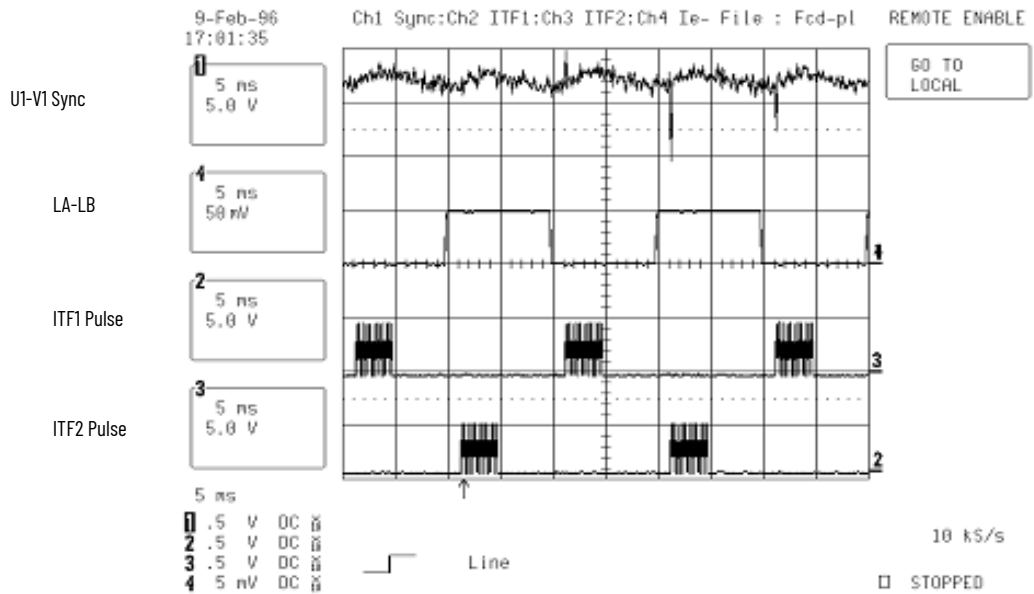

- If the gate signals are missing, replace the control board.
- If the gate signals are present, replace the field board.

Power Component Test Procedures

Check the Armature SCR Modules

The TPDflex DC Converter armature supply consists of three (non-regenerative drives) or six (regenerative drives) SCR modules mounted on heat sinks within the legs assemblies. A malfunction of any of these devices will be indicated by either an Overcurrent fault (F13), blown or tripped incoming protection devices, or erratic motor operation. The following procedure can be used if an armature bridge component malfunction is suspected.

1. Read the [General Safety Precautions on page 9](#).
2. Remove and lock-out all incoming power for the drive. See [Remove Power from the Drive on page 39](#).
3. Verify that contactor power (if used) is removed.
4. Verify that power to an external field supply (if used) is removed.
5. Check the anode to cathode junction of each SCR. With a digital multimeter set to Ohms, measure the resistance across the SCRs (lead orientation is not critical).
 - For regenerative drives, see [Table 3 on page 27](#) and [Figure 9 on page 28](#).
 - For non-regenerative drives, see [Table 4 on page 28](#) and [Figure 10 on page 29](#).

If a low resistance is detected, determine which SCR module(s) is/are damaged based on the tables below and replace that module(s). See [SCR Modules Removal and Installation on page 85](#).

Table 3 - SCR Anode to Cathode Junction Measurements for Regenerative Drives

On SCR Module	SCR	Measure from Terminal	To Terminal	Nominal meter reading
1	1	U	C	"open circuit" or "megaOhms" range
	4	U	D	
2	2	V	C	
	5	V	D	
3	3	W	C	
	6	W	D	
01	01	U	C	
	04	U	D	
02	02	V	C	
	05	V	D	
03	03	W	C	
	06	W	D	

Figure 9 - Regenerative Drive SCR Module Layout

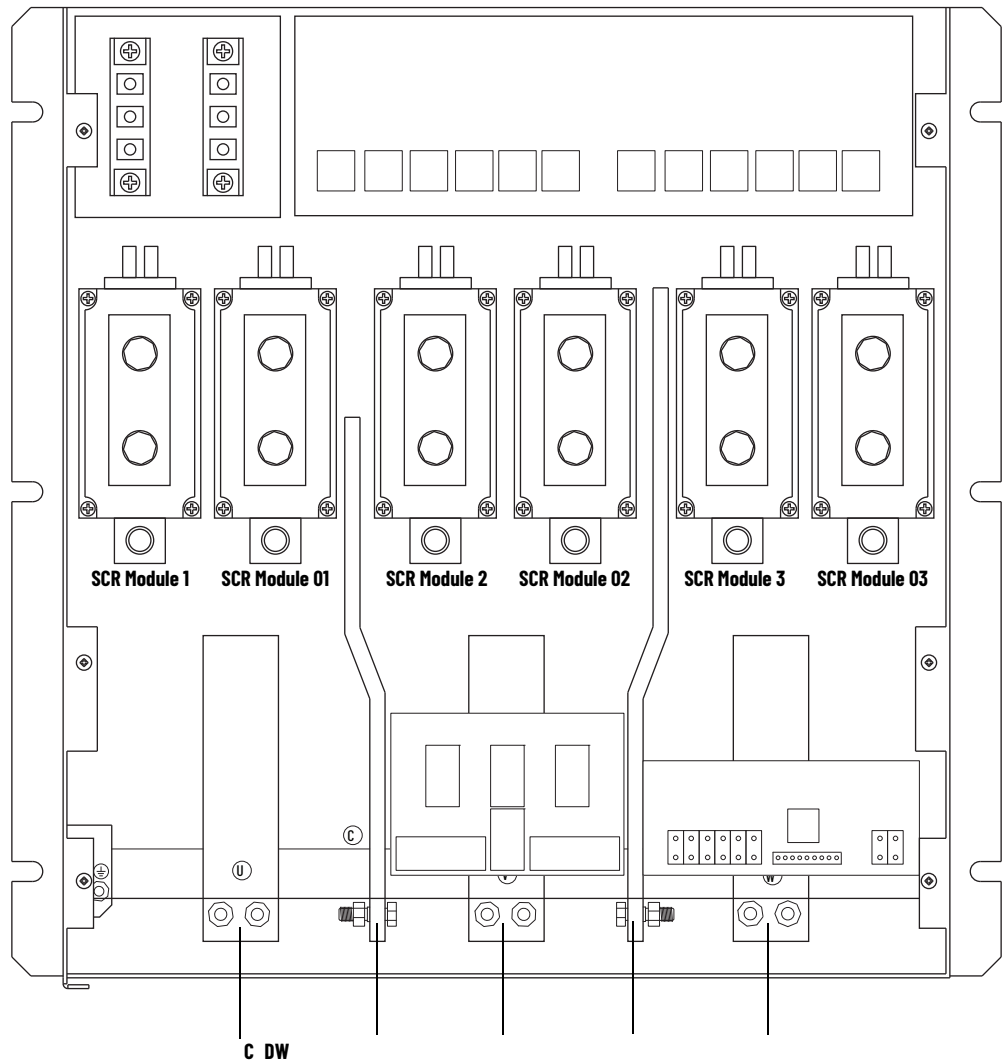
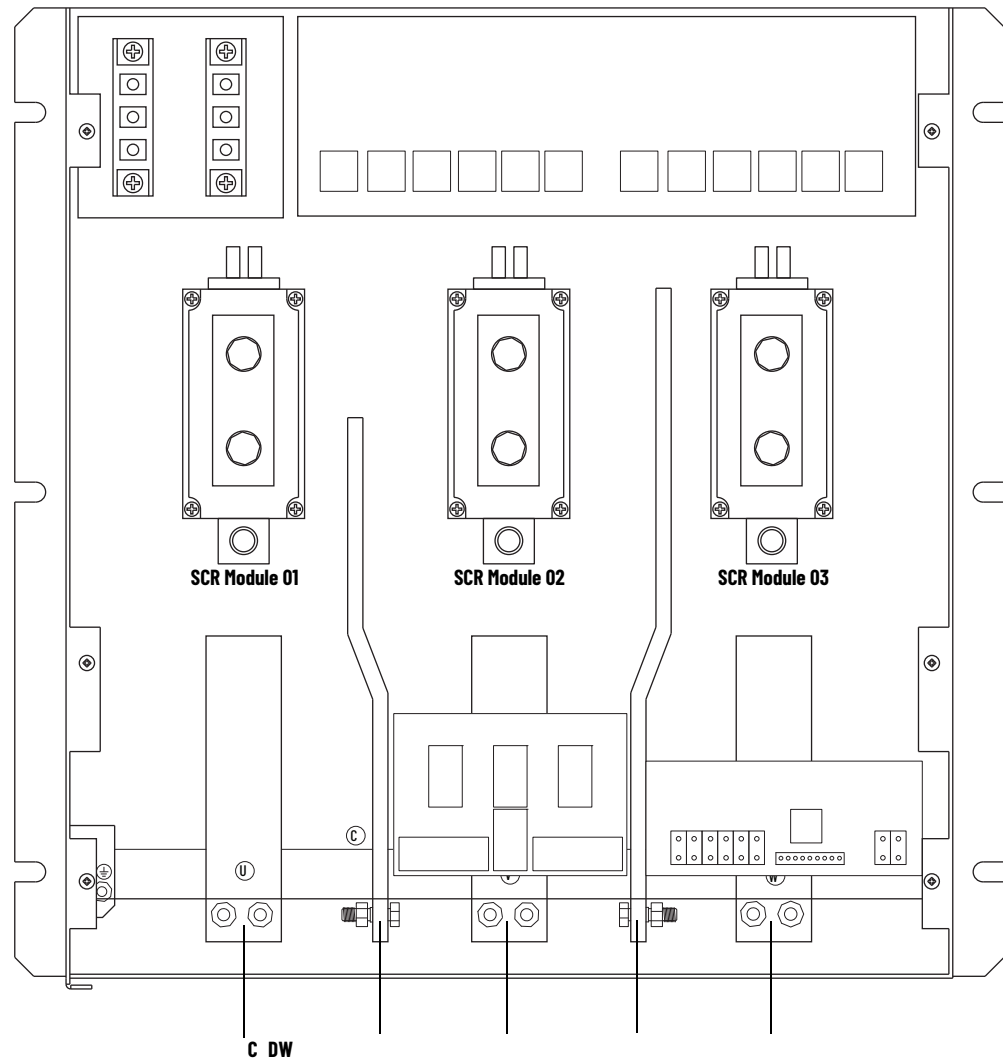

Table 4 - SCR Anode to Cathode Junction Measurements for Non-Regenerative Drives

On SCR Module	SCR	Measure from Terminal	To Terminal	Nominal meter reading
01	01	U	C	"open circuit" or "megaohms" range
	04	U	D	
02	02	V	C	
	05	V	D	
03	03	W	C	
	06	W	D	

Figure 10 - Non-Regenerative Drive SCR Module Layout



6. Check the gate to cathode junction of each SCR. With a digital multimeter set to Ohms, measure the resistance of each SCR junction.

- For regenerative drives, see [Table 5](#) and [Figure 11](#).
- For non-regenerative drives, see [Table 6 on page 30](#) and [Figure 12 on page 31](#).

If a measurement is outside of the range specified in the table, or if one reading deviates significantly from the majority, then module replacement may be necessary. See [SCR Modules Removal and Installation on page 85](#).

Table 5 - SCR Gate to Cathode Junction measurements for Regenerative Drives

On SCR Module	SCR	Measure from	To	Nominal meter reading
1	1	Pin 5	Pin 4	5...20 Ω ⁽¹⁾
	4	Pin 6	Pin 7	
2	2	Pin 5	Pin 4	
	5	Pin 6	Pin 7	
3	3	Pin 5	Pin 4	
	6	Pin 6	Pin 7	
01	01	Pin 6	Pin 7	
	04	Pin 5	Pin 4	
02	02	Pin 6	Pin 7	
	05	Pin 5	Pin 4	
03	03	Pin 6	Pin 7	
	06	Pin 5	Pin 4	

(1) The actual reading varies depending upon the SCR manufacturer. Verify that the actual measured value is consistent for all SCRs.

Figure 11 - SCR Gate Lead Connection Pinouts for Regenerative Drives

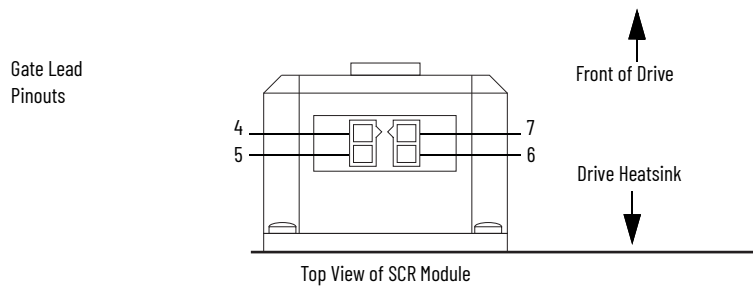
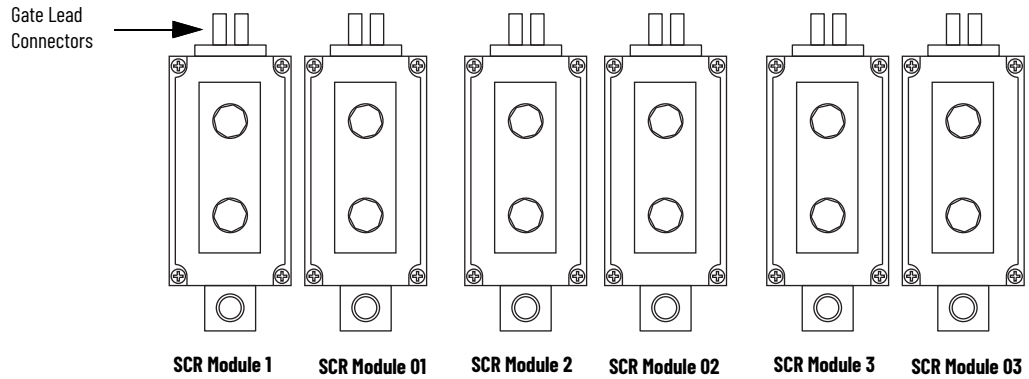
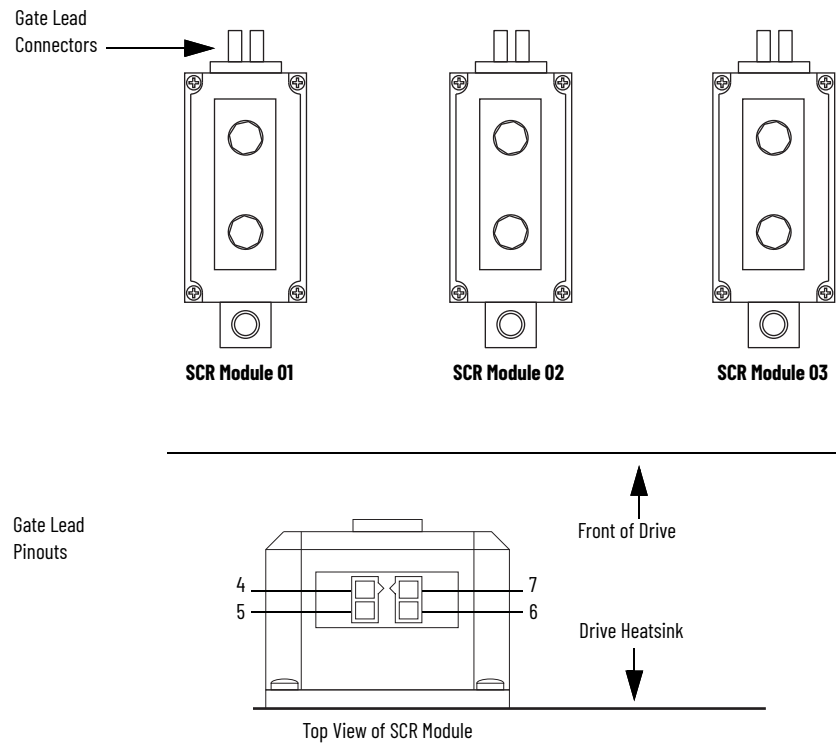

Table 6 - SCR Gate to Cathode Junction Measurements for Non-Regenerative Drives

On SCR Module	SCR	Measure from	To	Nominal meter reading
01	01	Pin 6	Pin 7	5...20 Ω ⁽¹⁾
	04	Pin 5	Pin 4	
02	02	Pin 6	Pin 7	
	05	Pin 5	Pin 4	
03	03	Pin 6	Pin 7	
	06	Pin 5	Pin 4	

(1) The actual reading varies depending upon the SCR manufacturer. Verify that the actual measured value is consistent for all SCRs.

Figure 12 - SCR Gate Lead Connection Pinouts for Non-Regenerative Drives



Check the Pulse Transformer Board

The armature pulse transformer circuit board contains an isolated gate firing circuit and also provides dv/dt protection for the armature SCR modules. A malfunction of these devices will be indicated by either an Overcurrent fault (F13), blown or tripped incoming protection devices or erratic motor operation. Use the following procedure if a malfunction in this circuitry is suspected.

1. Read the [General Safety Precautions on page 9](#).
2. Remove power from the drive. See [Remove Power from the Drive on page 39](#).
3. Remove the pulse transformer board (see [Pulse Transformer Circuit Board Removal and Installation on page 58](#)).
4. With a digital multimeter set for a "continuity check", measure each connection point on the pulse transformer board listed in the tables below. See [Figure 30 on page 122](#) for connector locations.

If any of the actual measurements are out of tolerance, replace the pulse transformer board.

Table 7 - Armature Pulse/Snubber Circuit Measurements for Regenerative Drives



For SCR	Measure From	To	Meter reading	Connector	Pinout
1	KG1	XY-4	"open circuit"		
4	KG4	XY-1			
2	KG2	XY-5			
5	KG5	XY-2			
3	KG3	XY-6			
6	KG6	XY-3			
01	KG01	XY-1			
04	KG04	XY-4			
02	KG02	XY-2			
05	KG05	XY-5			
03	KG03	XY-3			
06	KG06	XY-6			

Table 8 - Armature Pulse/Snubber Circuit Measurements for Non-Regenerative Drives

For SCR	Measure From	To	Meter reading	Connector	Pinout
01	KG1	XY-1	"open circuit"		
04	KG4	XY-4			
02	KG2	XY-2			
05	KG5	XY-5			
03	KG3	XY-3			
06	KG6	XY-6			

- With the digital multimeter set to "diode test", measure each connection point on the pulse transformer board listed in the tables below. If any of the actual measurements are out of tolerance, replace the pulse transformer board.

Table 9 - Armature Pulse Transformer Primary Measurements for Regenerative and Non-Regenerative Drives



For SCR	Meter Lead	Meter Lead	Meter reading	Connector	Pinout
1/01	XY-8	XY-1	0.41 Ω		
4/04	XY-8	XY-4			
2/02	XY-8	XY-2			
5/05	XY-8	XY-5			
3/03	XY-8	XY-3			
6/06	XY-8	XY-6			

Table 10 - Armature Pulse Transformer Primary Measurements for Regenerative Drives

For SCR	Meter Lead	Meter Lead	Meter reading	Connector	Pinout
1	XY-7	XY-1	0.41 Ω		
4	XY-7	XY-4			
2	XY-7	XY-2			
5	XY-7	XY-5			
3	XY-7	XY-3			
6	XY-7	XY-6			

Check the Field SCR/Dual Diode Module

The field supply consists of a dual pack SCR/dual diode module arranged in a single-phase full wave rectifier configuration. Malfunction of either of these components may cause various responses including field and velocity related faults, or blown fuses. The following procedures can be used if field bridge malfunctions are suspected.

1. Read the [General Safety Precautions on page 9](#).
2. Remove and lock-out all incoming power to the drive. See [Remove Power from the Drive on page 39](#).
3. Remove the protective covers. See [Protective Cover Removal and Installation on page 41](#).
4. Verify that contactor power (if used) is removed.
5. Verify that power to an external field supply (if used) is removed.
6. Disconnect the field wires from C1 and D1. See [Figure 13 on page 34](#)
7. Check the anode to cathode junction of the field SCR/dual diode module. With the digital multimeter set to "diode test", measure the resistance across the modules. See [Table 11](#) and [Figure 13](#) below.

If a low resistance is detected, replace the modules. See [Field SCR and Dual Diode Module Removal and Installation on page 66](#).

If a measurement results in an "infinity" reading, check the fuses at FU1 and FV1 on the control panel to determine if they are open. See [Figure 14 on page 34](#).

Table 11 - Field SCR/Dual Diode Module Anode to Cathode Junction Measurements

Meter Lead Terminal	Meter Lead Terminal	Nominal meter reading
U1	C1	"0.45V
U1	D1	open or infinity
V1	C1	open or infinity
V1	D1	open or infinity
C1	D1	open or infinity
C1	U1	open or infinity
C1	V1	open or infinity
D1	C1	0.9V
D1	U1	0.45V
D1	V1	open or infinity

Figure 13 - Field Terminal Block Location

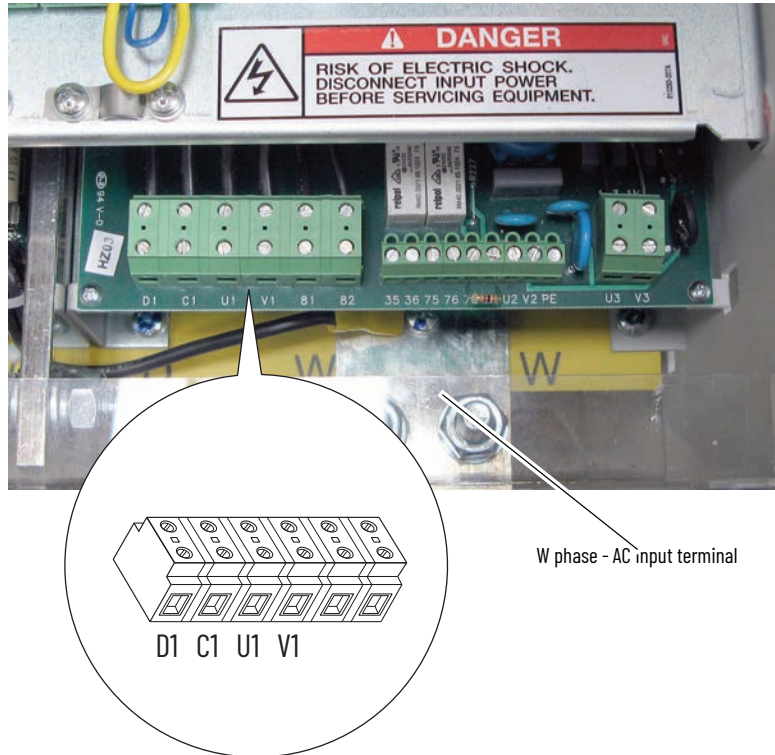
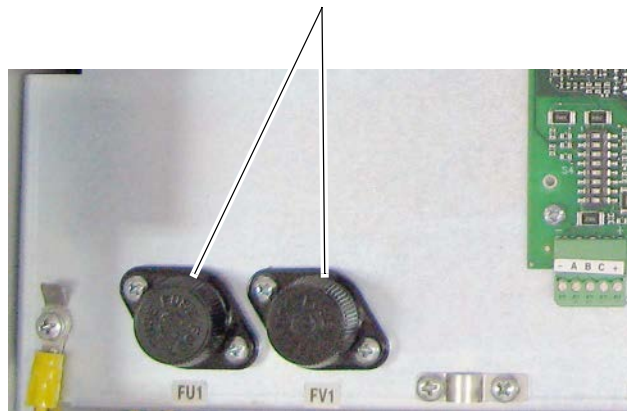

Figure 14 - Field Fuses Location

The field fuses are located on the control EMI shield next to the control board



8. Remove the cable from connector XP on the pulse transformer circuit board. See [Figure 30 on page 122](#) for connector location.
9. Check the gate cathode junction of the field SCR/dual diode module. With the digital multimeter set to "diode test" measure the resistance across the modules (lead orientation is not critical). See [Table 12](#) below.

If a low resistance is detected, replace the SCR/dual diode module. See [Field SCR and Dual Diode Module Removal and Installation on page 66](#).

Table 12 - SCR/Dual Diode Module Gate Cathode Junction Measurements

Measure from	To	Nominal meter reading
XP1	XP2	10...20 Ω
XP3	XP4	

Speed Feedback Device Tests

Check the Encoder

The encoder feedback device provides a dual channel quadrature output waveform and requires that the output be differential line drivers at +5 or +12...15V signal levels. The encoder power supply voltage and input selection is controlled by DIP switch S21 on the control board (see "DIP Switch and Jumper Settings" in the TPDflex DC Converters User Manual, publication 1S7TFLEXUM0). The encoder power supply from the drive can be measured from +V (+) to COM (-) with a digital multimeter. If S21 is set to ENC_5, the voltage level should be +2.5...5.4V. If S21 is set to ENC_12, the voltage level should be +5.4V...15.2V. For reference, see [Figure 22 on page 117](#) for a schematic diagram.

The Channel A and Channel B are square wave type outputs that are 90 degrees out of phase. When rotating in the counter clockwise direction, as viewed from the commutator end, Channel A leads Channel B. Each differential channel has an inverted and non-inverted signal.

Power for the encoder is provided internally and is capable of 200mA of current with a current foldback feature that protects the power supply should the current draw exceed 200mA. If different power supply requirements exist for the chosen feedback device, the supply must be provided external to the drive.

The frequency is proportional to speed and the pulse rate of the encoder, referred to as the "Pulse/Rev" rating on the nameplate. The speed of the motor can be calculated by: Speed (RPM) = [Frequency (Hz) x 60]/[Pulses/Revolution].

Check the DC Tachometer

- Verify that DIP switch S4 on the control board is set to the correct input voltage of the DC analog tachometer. See "DIP Switch and Jumper Settings" in the TPDflex DC Converters User Manual, publication 1S7TFLEXUM0). Also, see [Figure 23 on page 117](#) for a circuit diagram.
- The analog tach signal is fine scaled using parameter 562 [Anlg Tach Gain].
- See "Drive Reference and Feedback Scaling" in Appendix C of the TPDflex DC Converters User Manual, publication 1S7TFLEXUM0, for more information.

Check the Resolver Interface Board

The resolver feedback option module uses the resolver feedback board for resolver connections, and the resolver interface board for external power, status, feedback board reset, and encoder output connections.

If a fault F93 [Resolver Error] fault occurs and the resolver wiring and configuration are correct, the following LED indicators and testpoints on the resolver interface board can be used to verify that the board is not damaged.

- Verify that the following LEDs are functioning as expected. See [Figure 15 on page 36](#) for LED locations and switch settings.

LED Code	LED Color	On State	Off State
D3	Red	24V overload (fuse F1 blown). This fuse is self-resetting when it returns to normal operating temperature.	24V supply is OK.
D10	Green	12V supply is OK.	Loss of 12V power.
D11	Green	Resolver feedback board voltage is OK.	Voltage error on resolver feedback board.
D12	Blue	Switch S1 is set to +24V for encoder signal output on TB2.	S1 is <u>not</u> set for +24V.
D16	Yellow	Switch S1 is set to +12V for encoder signal output on TB2.	S1 is <u>not</u> set for +12V.
D18	Green	Switch S1 is set to +5V for encoder signal output on TB2.	S1 is <u>not</u> set for +5V.
D26	Red	Resolver feedback board is in reset mode.	Resolver feedback board <u>not</u> in reset mode.

If any of the LEDs that should turn on when control power is applied fail to do so, verify that the resolver interface and resolver feedback boards are properly seated on the appropriate connectors (XRE, P2, P3). If problems persist, replace the resolver interface and/or resolver feedback board.

- Measure the signal voltage at the testpoints as indicated in the following table. See [Figure 15 on page 36](#) for testpoint locations.

Testpoint	to	Testpoint	Measurement
+12V	...	OV12	12V DC ±5%
-12V	...	OV12	-12V DC ±5%
+24V_VI	...	OV24	24V DC ±5%
+5V	...	OV5	5V DC ±5%

If any of the voltage measurements fails, replace the resolver interface board.

Figure 15 - Resolver Interface Board Testpoint Locations

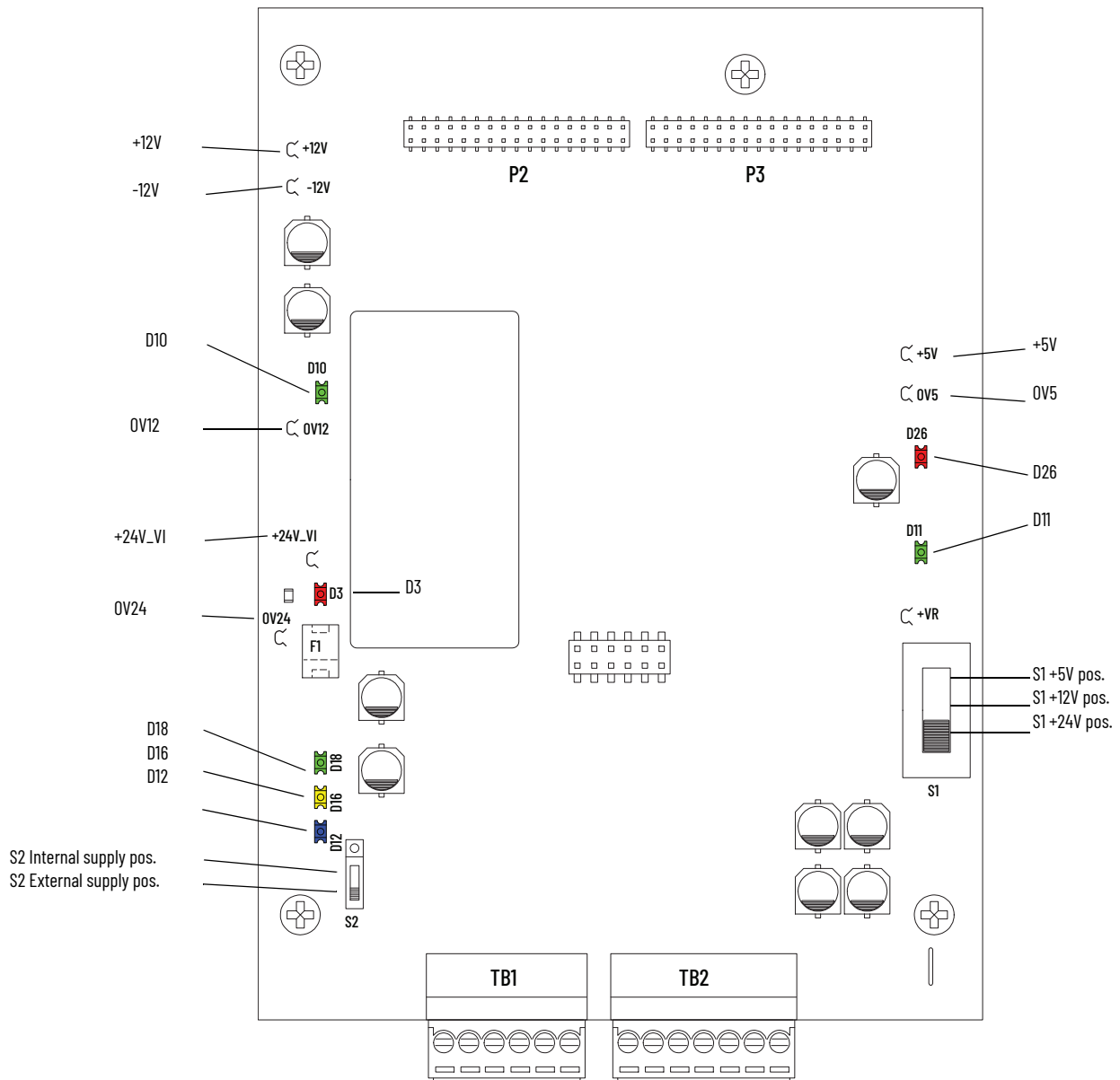

Thermistors and Thermal Switches

Motor overheating is detected by an external, user-supplied thermistor (PTC) or thermal switch connected to terminals 78 and 79 on the control power terminal block on the lower, right corner of the pulse transformer circuit board. See [Figure 30 on page 122](#) for terminal block location.

Motor overheating is typically identified by a “Motor Over Temp” fault (F16). See “Fault Descriptions” in Chapter 4 of the TPDflex DC Converters User Manual, publication 1S7TFLEXUMO for details. See [Figure 24 on page 118](#) for a circuit diagram.

- If a thermal switch is used, a 1 k Ω resistor must be placed in series between the switch and either terminal 78 or 79.
- If neither a thermistor (PTC) or a thermal switch is installed, a 1 k Ω resistor must be connected between terminals 78 and 79.

The drive heatsink temperature is monitored by a bimetal thermostat connected directly to the heatsink. When the heatsink temperature is too high, a “Heatsink OvrTemp” fault (F8) occurs. See “Fault Descriptions” in Chapter 4 of the TPDflex DC Converters User Manual, publication 1S7TFLEXUMO for details. See [Figure 25 on page 118](#) for a circuit diagram.

During normal operation, 1.6V DC is present between terminal 78 and drive common. When an open circuit exists between terminals 78 and 79, 24V DC will be present at terminal 78 to drive common. If the 24V is missing, the pulse transformer board may need replacement.

Relay Outputs

Terminals 35 and 36 and 75 and 76 are normally open. relay outputs. The relay output between terminals 35 and 36 is configured with parameter 1392 [Relay Out 1 Sel]. The relay output between terminals 75 and 76 is configured with parameter 629 [Relay Out 2 Sel]. See “Using Contactors” in Chapter 1 of the TPDflex DC Converters User Manual, publication 1S7TFLEXUMO, for more information.

The “Main Contactor” fault (F10) indicates a problems related to a contactor used with the drive. See “Fault Descriptions” in Chapter 4 of the TPDflex DC Converters User Manual, publication 1S7TFLEXUMO for details.

Create a Fault Report

Complete fault reports are critical for analysis and repair of modules returned to the factory.

At a minimum, perform and record the following:

- Record the contents of the fault queue (faults and times of occurrence). See the TPDflex DC Converters User Manual, publication 1S7TFLEXUMO, for detailed Fault and Alarm codes and descriptions.
- Make a record of any burn marks on the printed circuit boards, cabling, bus bars, and SCR modules
- Make a record of any liquid and condensation marks on the printed circuit boards, components and mechanical parts
- Make a record of the amount of dust and other additional particles on the drive and drive components
- Make a record of any mechanical damage to the drive and drive components
- Record the size and type of main fuses
- Record any other important marks and damage

What You Need When You Call Tech Support

When you contact Technical Support, please be prepared to provide the following information:

- Order number
- Product catalog number and drives series number (if applicable)
- Product serial number
- Firmware revision level
- Most recent fault code
- Your application

You can use the table below to record the data provided in each TPDflex DC Converter parameter listed.

Param s	Name	Description	Parameter Data
1349	Status1 at Fault	Captures and displays Par 381 [Drive Status 1] bit pattern at the time of the last fault.	
1350	Status2 at Fault	Captures and displays Par 382 [Drive Status 2] bit pattern at the time of the last fault.	
1351-1360	Fault x Code	A code that represents the fault that tripped the drive. The codes will appear in these parameters in the order they occur (i.e., [Fault 1 Code] = the most recent fault).	
1361-1370	Fault x Time	The time between initial drive power up and the occurrence of the associated trip fault.	
1371	Fault Arm Amps	Captures and displays the armature current (as a percentage of rated current) at the time of the last fault.	
1372	Fault Speed	Captures and displays the output speed (rpm) of the drive at the time of the last fault.	
1373	Fault Field Amps	Captures and displays the field current (as a percentage of rated current) at the time of the last fault.	
1374	Fault Voltage	Captures and displays the armature voltage at the time of the last fault.	

Access Procedures

Topic	Page
Remove Power from the Drive	39
DPI / HIM Assembly Removal and Installation	40
Protective Cover Removal and Installation	41
Field Circuit Fuses Removal and Installation	43
Communication Adapter and EMI Shield Removal and Installation	43
Resolver Feedback and Interface Circuit Board Removal and Installation	46
I/O Expansion Circuit Board Removal and Installation	48
115V AC to 24V DC I/O Converter Circuit Board Removal and Installation	50
Control Circuit Board Removal and Installation	51
Control EMI Shield Removal and Closure	54
Switching Power Supply Circuit Board Fuse Removal and Installation	56
Switching Power Supply Circuit Board Removal and Installation	57
Pulse Transformer Circuit Board Removal and Installation	58
Field Power Circuit Board Removal and Installation	65
Field SCR and Dual Diode Module Removal and Installation	66
AC Line Snubber Circuit Board and Resistors Removal and Installation	68
Transient Noise Filter Circuit Board Fuses Removal and Installation	74
Transient Noise Filter Circuit Board Removal and Installation	75
Power Supply Filter Circuit Board Removal and Installation	79
Armature Leg Fuses Removal and Installation	82
SCR Modules Removal and Installation	85
AC Current Transducers Removal and Installation	93
Bimetal Thermostats Removal and Installation	98
Cooling Fans Removal and Installation	107

Remove Power from the Drive



ATTENTION Remove power before making or breaking cable connections. When you remove or insert a cable connector with power applied, an electrical arc may occur. An electrical arc can cause personal injury or property damage by:

- sending an erroneous signal to your system's field devices, causing unintended machine motion
 - causing an explosion in a hazardous environment
- Electrical arcing causes excessive wear to contacts on both the module and its mating connector. Worn contacts may create electrical resistance.

1. Remove and lock-out all incoming power to the drive.

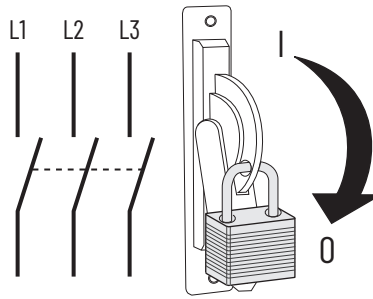

DPI / HIM Assembly Removal and Installation

Remove the DPI / HIM Assembly

1. Read the [General Safety Precautions on page 9](#).
2. Remove power from the drive. See [Remove Power from the Drive on page 39](#).
3. Disconnect the DPI cable from the HIM assembly.
4. Remove the screw that secures the DPI / HIM assembly to the drive.
5. Carefully remove the DPI / HIM assembly from the cover and disconnect the cable from the DPI connector on the back side of the assembly.

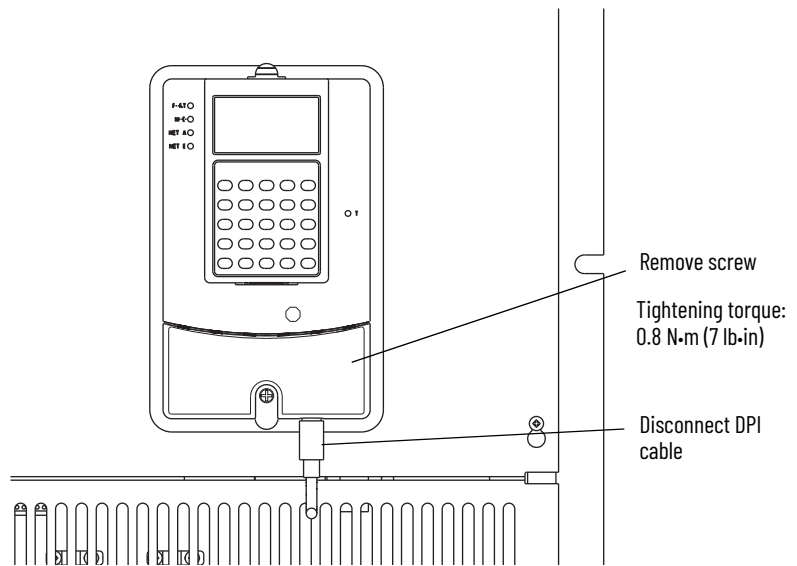

Install the DPI / HIM Assembly

Install the DPI / HIM assembly in reverse order of removal.

Protective Cover Removal and Installation

Remove the Protective Covers from the Drive

1. Read the [General Safety Precautions on page 9](#).
2. Remove power from the drive. See [Remove Power from the Drive on page 39](#).
3. Disconnect the DPI cable from the HIM assembly.
4. Loosen, but do not remove, the screws that secure the bottom cover to the drive, then slide the cover down and off the drive chassis.

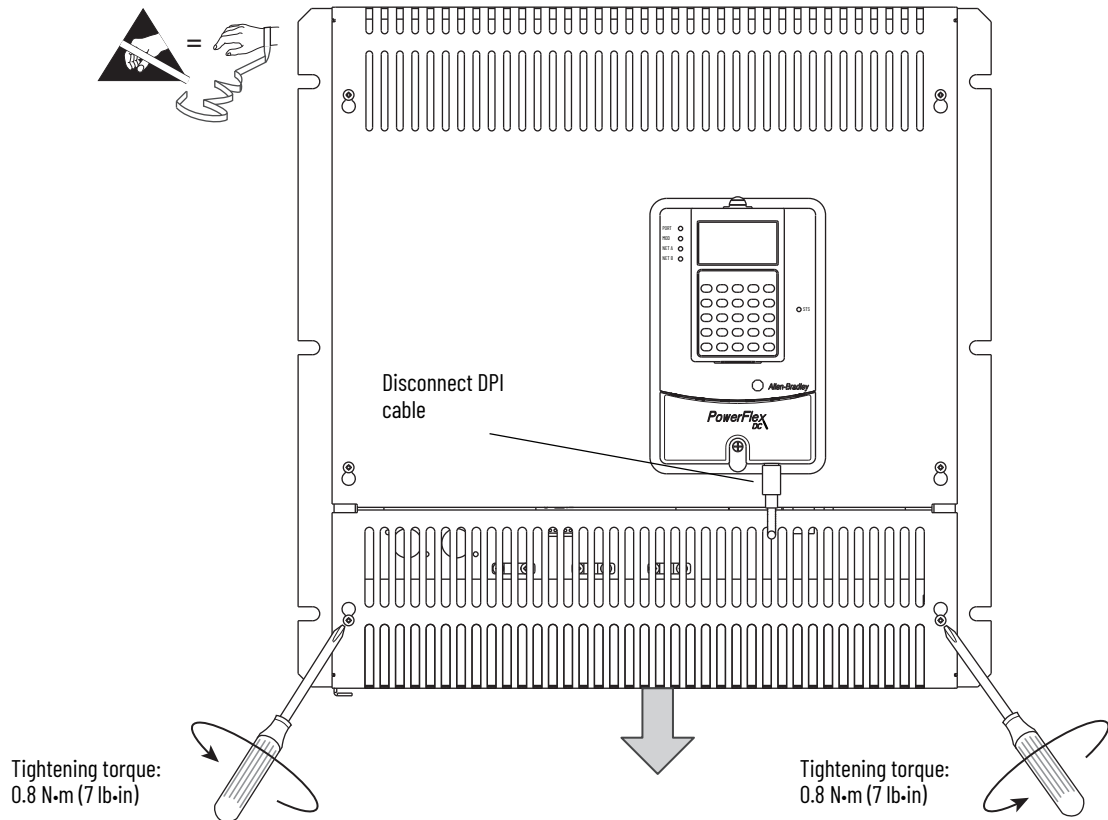

5. Loosen, but do not remove, the screws that secure the top cover to the drive, then slide the cover up and off the drive chassis.

IMPORTANT The HIM assembly is connected via a cable to the control board and therefore will not pull free from the drive until disconnected. See [step 5](#) below for instructions.

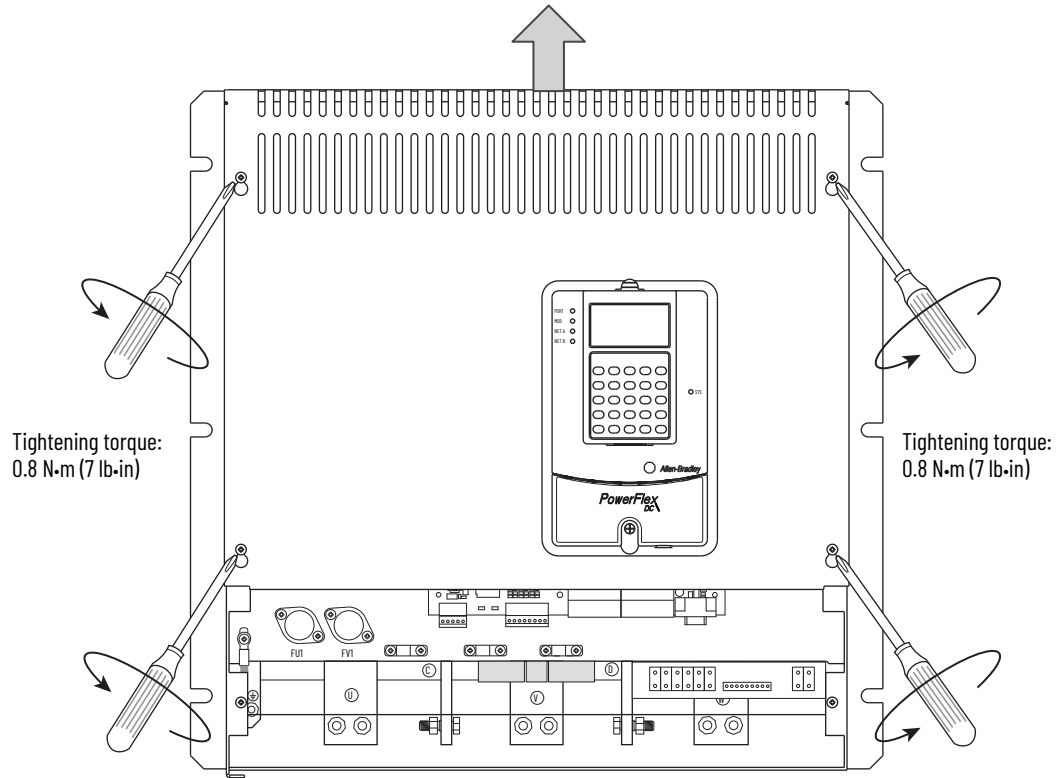

6. Disconnect the HIM communication cable from the connector on the upper right corner of the control board and set the cover aside.

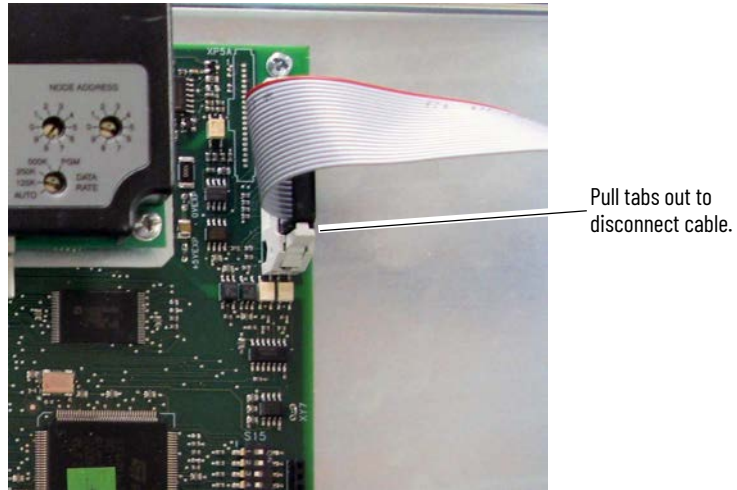

Install the Protective Covers on the Drive

Install the protective covers in the reverse order of removal.

Field Circuit Fuses Removal and Installation

Remove the Field Circuit Fuses

1. Read the [General Safety Precautions on page 9](#).
2. Remove power from the drive. See [Remove Power from the Drive on page 39](#).
3. Remove the lower protective cover only from the drive. See [Protective Cover Removal and Installation on page 41](#).
4. On the control EMI shield, unscrew the fuse holders and remove the existing fuses from the holders.

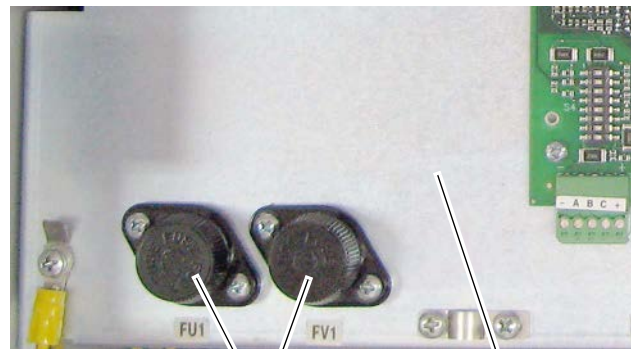

Unscrew fuse caps
and remove fuses

Control EMI shield

Install the Field Circuit Fuses

Install the field circuit fuses in the reverse order of removal.

Communication Adapter and EMI Shield Removal and Installation

Remove the Communication Adapter and EMI Shield

1. Read the [General Safety Precautions on page 9](#).
2. Remove power from the drive. See [Remove Power from the Drive on page 39](#).
3. Remove the Protective Covers from the drive. See [Protective Cover Removal and Installation on page 41](#).
4. Disconnect the interface cable from the communication adapter and set it aside.
5. Disconnect any network cables from the adapter and set them aside.

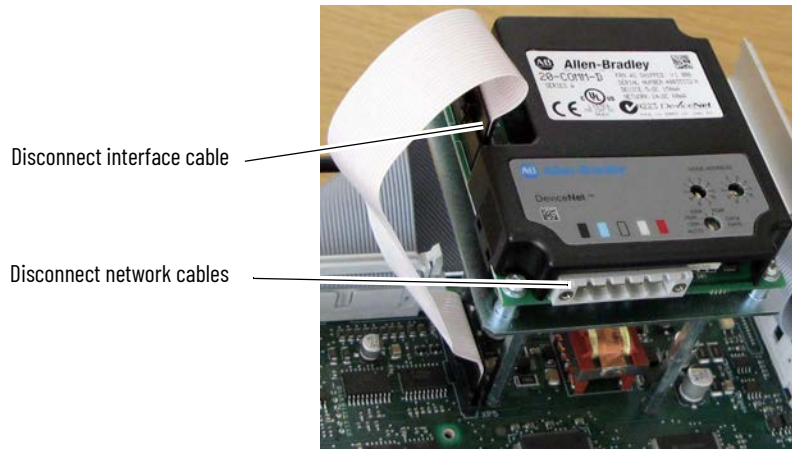

6. Remove the four screws and washers that secure the communication adapter to the EMI shield and remove the adapter.

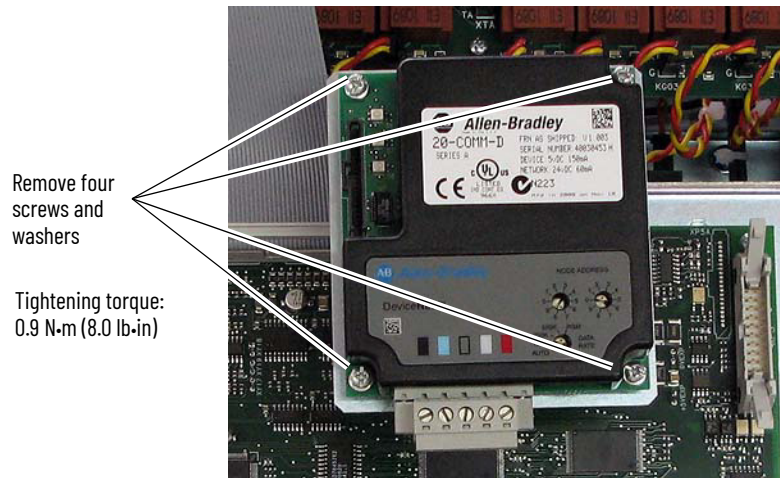

7. Remove the three screws and washers that secure the EMI shield to the standoffs on the control board and remove the EMI shield.

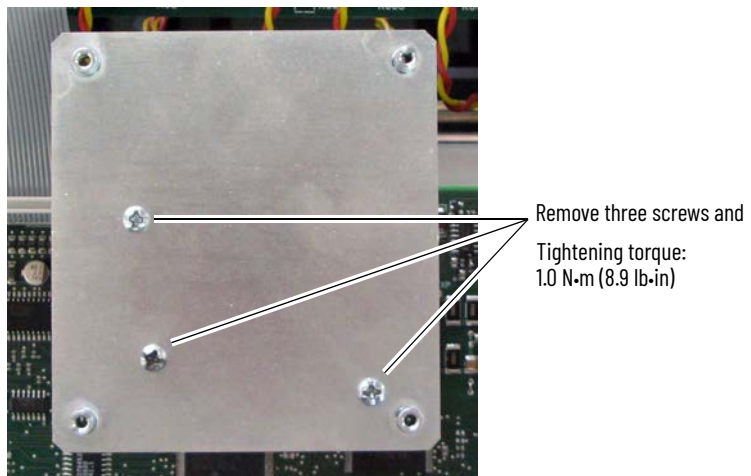

8. Remove the three standoffs and washers from the control board.

Remove three standoffs and washers
Tightening torque:
1.0 N·m (8.9 lb-in)

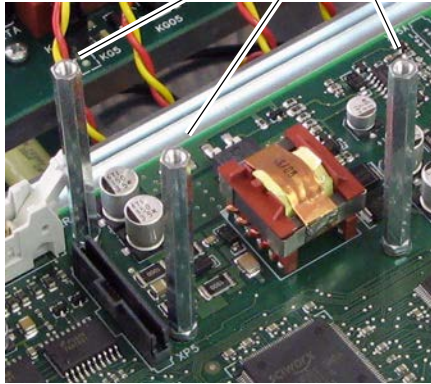

Install the Communication Adapter and EMI Shield

Install the communication adapter and EMI shield in reverse order of removal.

Resolver Feedback and Interface Circuit Board Removal and Installation

Remove the Resolver Feedback and Interface Circuit Boards

1. Read the [General Safety Precautions on page 9](#).
2. Remove power from the drive. See [Remove Power from the Drive on page 39](#).
3. Remove the protective covers from the drive. See [Remove the Protective Covers from the Drive on page 41](#).

IMPORTANT Mark all connections and wires before removal to avoid incorrect wiring during reassembly.

4. Disconnect the plug-in terminal blocks from the resolver feedback and resolver interface boards.

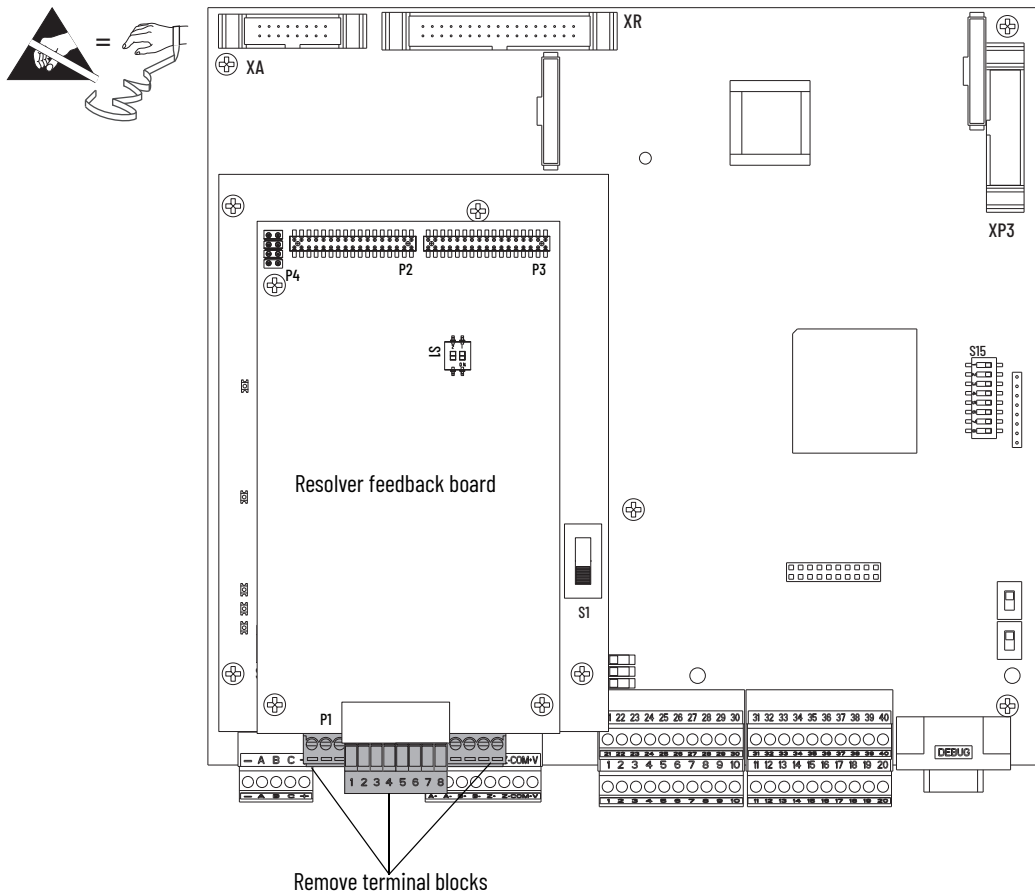

5. Remove the three hexalobular screws that secure the resolver feedback board to the stand-offs on the resolver interface board and carefully remove the resolver feedback board.

IMPORTANT The resolver feedback board is connected to the resolver interface board below it via stacker connector pins at connectors P2 and P3. Lift the resolver feedback board straight up during removal to avoid any damage to the connector pins.

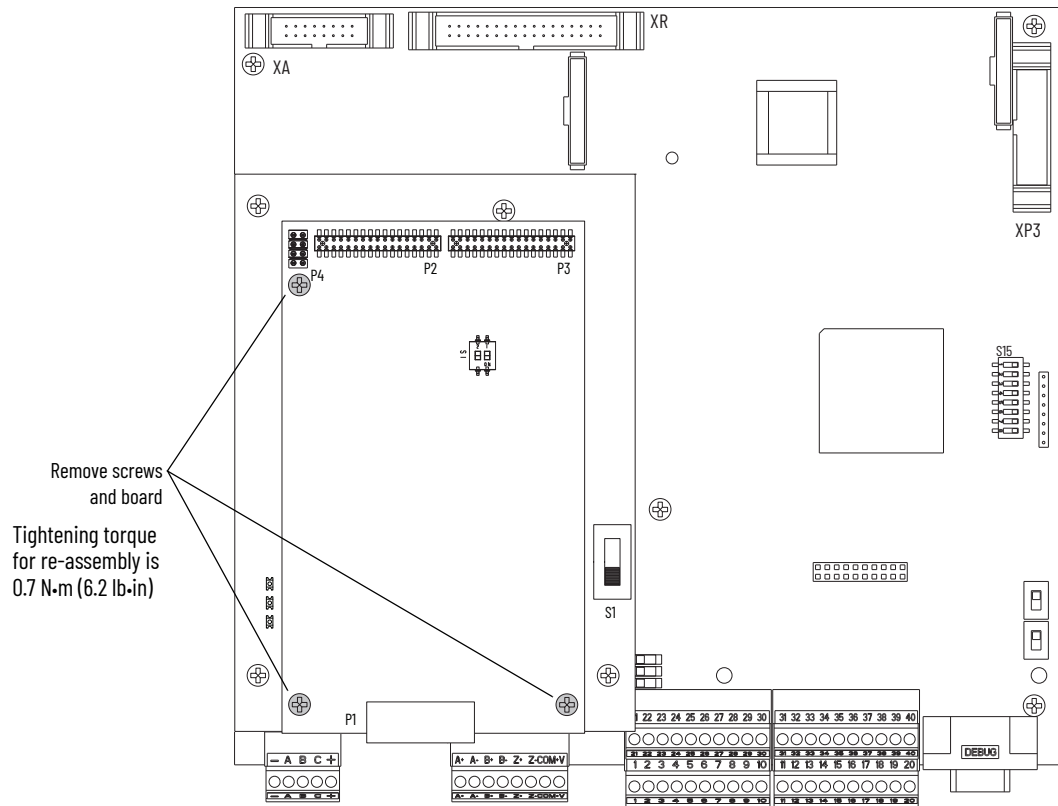

6. Remove the three stand-offs from the resolver interface board.

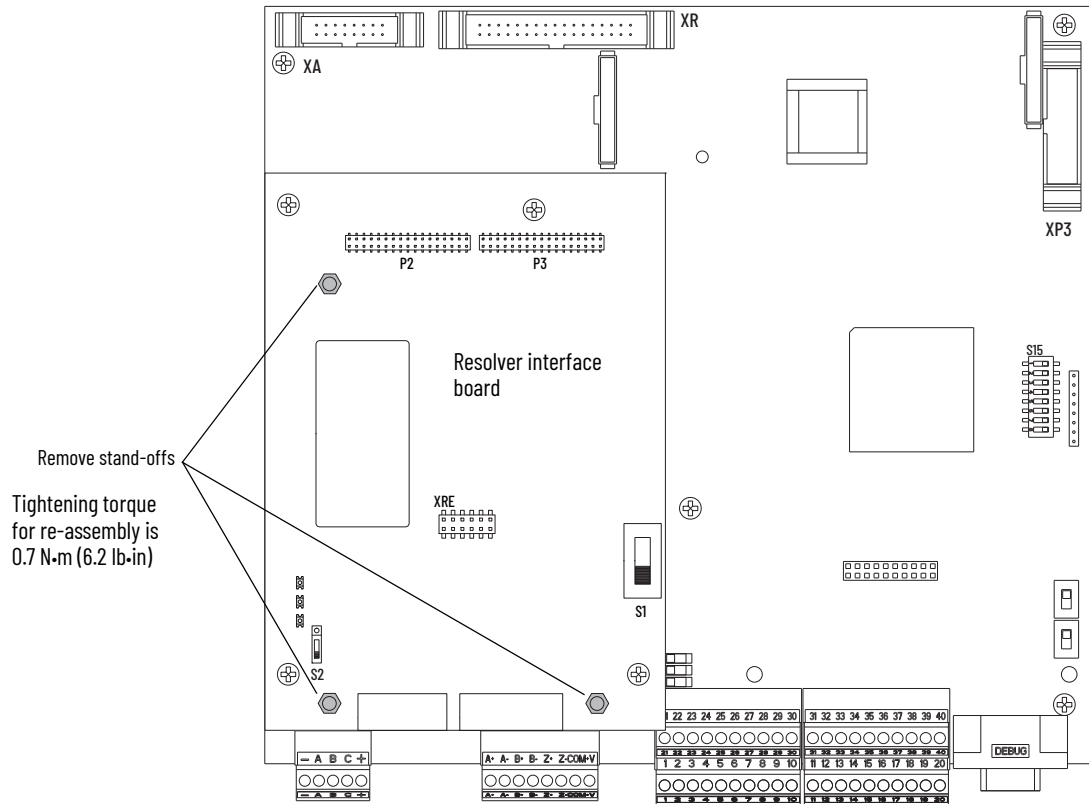

7. Remove the four hexalobular screws that secure the resolver interface board to the control board and remove the resolver interface board.

IMPORTANT The resolver interface board is connected to the control board below it via a stacker connector pin at connector XRE. Lift the resolver interface board straight up during removal to avoid any damage to the connector pin.

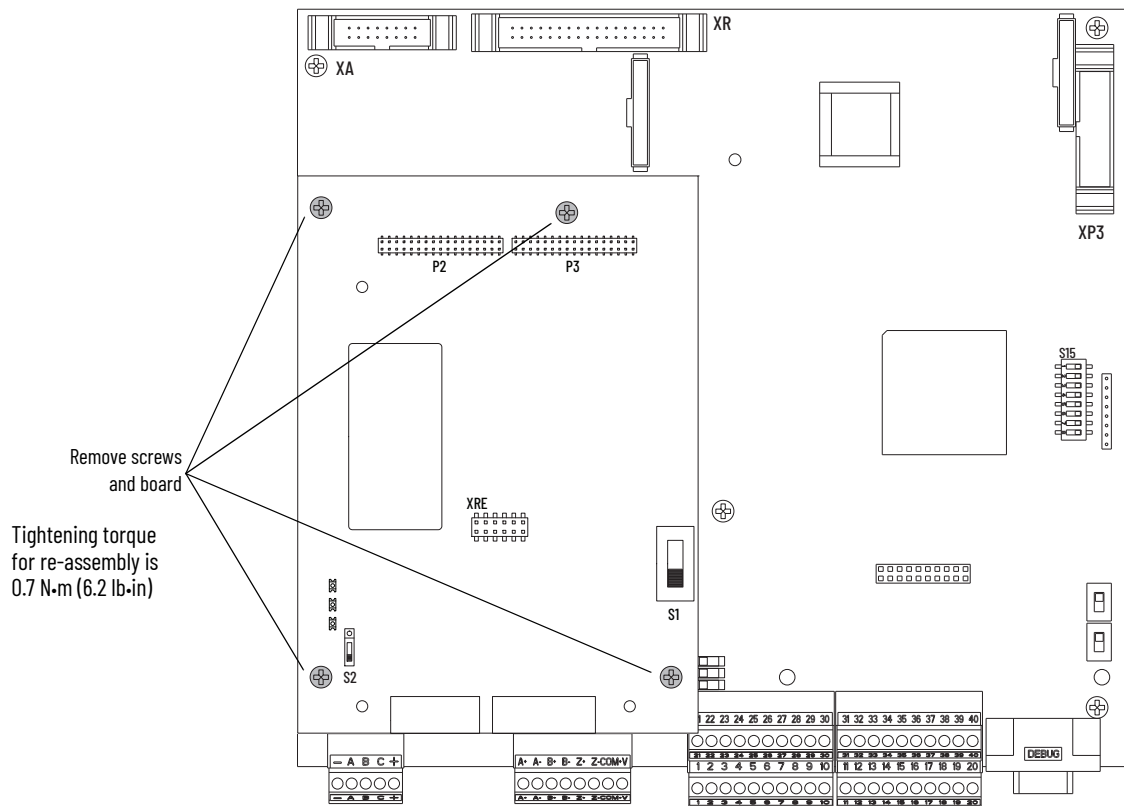

Install the Resolver Feedback and Interface Circuit Boards

Install the resolver feedback and interface boards in reverse order of removal.

I/O Expansion Circuit Board Removal and Installation

Remove the I/O Expansion Circuit Board

1. Read the [General Safety Precautions on page 9](#).
2. Remove power from the drive. See [Remove Power from the Drive on page 39](#).
3. Remove the covers from the drive. See [Protective Cover Removal and Installation on page 41](#).
4. If installed, remove the resolver feedback option board. See [Remove the Resolver Feedback and Interface Circuit Boards on page 46](#).

IMPORTANT Mark all connections and wires before removal to avoid incorrect wiring during reassembly.

5. Remove the plug-in I/O terminal blocks with the wiring kept in place.
6. Remove the two screws that secure the I/O expansion board to the stand-offs on the control board.

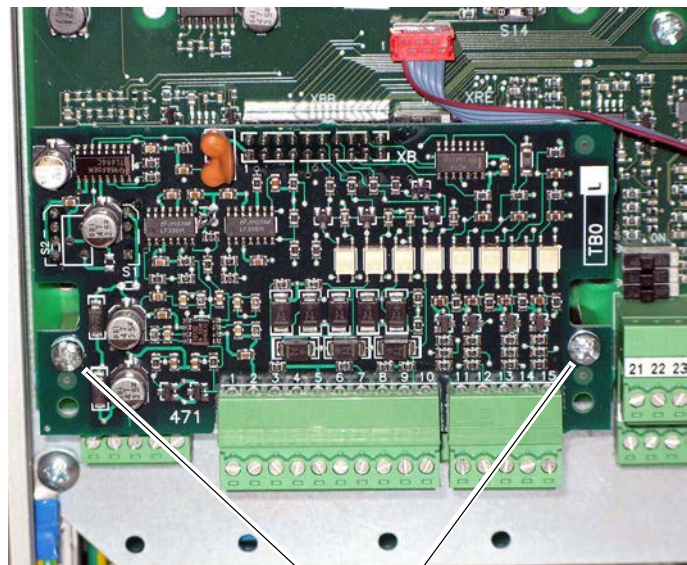

Remove two screws
Tightening torque
for re-assembly is
1.0 N·m (8.9 lb·in)

7. Carefully pull the I/O expansion board off connector XBB on the control board.
8. Remove the two stand-offs and washers from the control board.

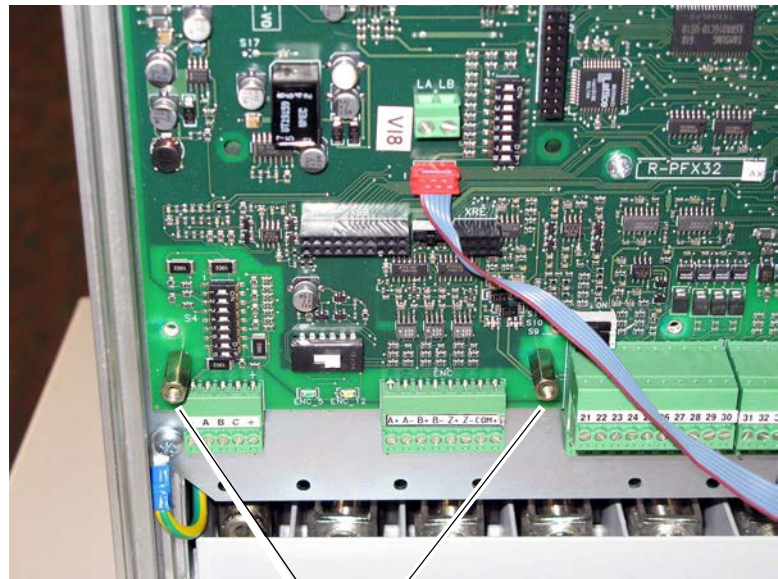

Remove two stand-offs and
washers

Tightening torque for re-
assembly is
1.0 N·m (8.9 lb·in)

9. Install one screw in the lower left corner of the control circuit board.

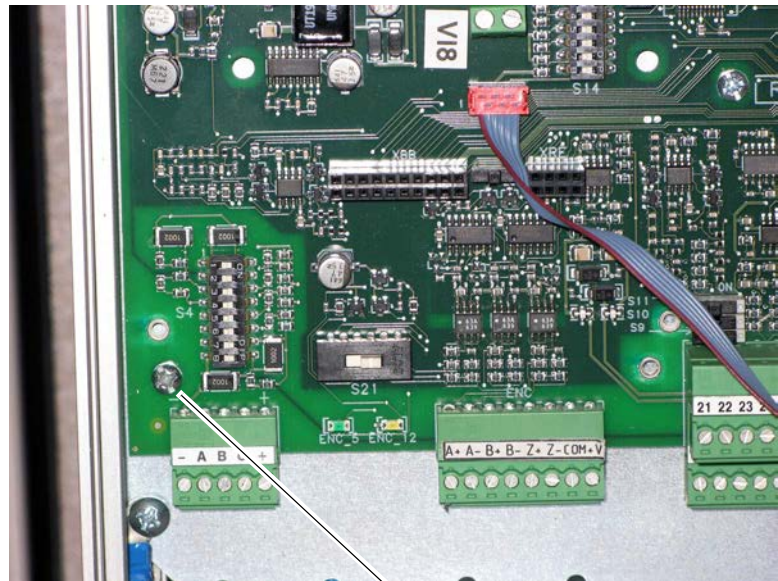

Install screw Tightening torque for re-assembly is 1.0 N·m (8.9 lb·in)

Install the I/O Expansion Circuit Board

Install the I/O expansion board in reverse order of removal.

115V AC to 24V DC I/O Converter Circuit Board Removal and Installation

Remove the 115V AC to 24V DC I/O Converter Circuit Board

1. Read the [General Safety Precautions on page 9](#).
2. Remove power from the drive. See [Remove Power from the Drive on page 39](#).
3. Remove the covers from the drive. See [Remove the Protective Covers from the Drive on page 41](#).

IMPORTANT Mark all connections and wires before removal to avoid incorrect wiring during reassembly.

4. Remove the plug-in I/O terminal block with the wiring kept in place.
5. Remove the two screws that secure the I/O converter board to the stand-offs on the control board and remove the I/O converter board.

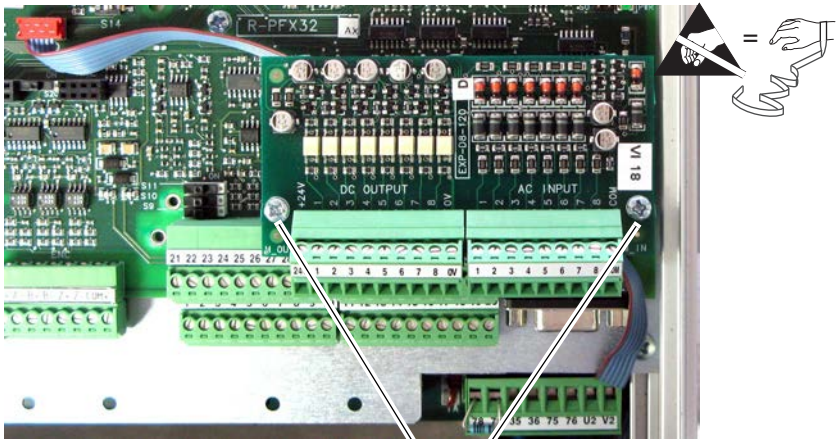

Remove two screws

Tightening torque for re-assembly is 1.0 N·m (8.9 lb·in)

6. Remove the two stand-offs and washers from the control board.

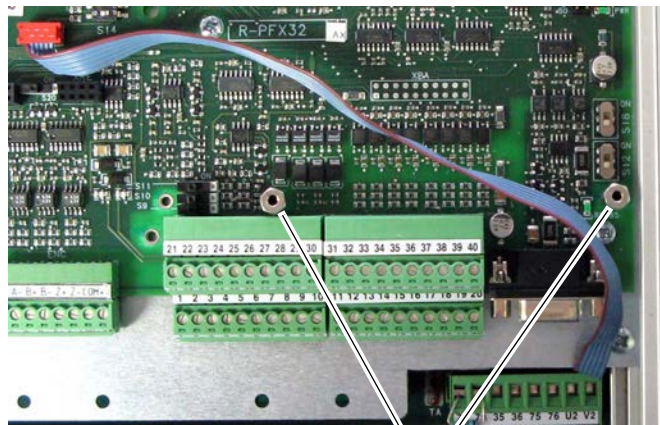

Remove two stand-offs and washers

Tightening torque for re-assembly is 1.0 N·m (8.9 lb·in)

Install the 115V AC to 24V DC I/O Converter Circuit Board

Install the 115V AC to 24V DC I/O converter board in reverse order of removal.

Control Circuit Board Removal and Installation

Remove the Control Circuit Board

1. Save the drive and adapter parameter configuration to a HIM set or by downloading the drive and adapter parameters to an offline database file using DriveExecutive. Refer to the TPDFlex DC Converters User Manual, publication 1S7TFLEXUMO for information on using the HIM or the on-line help provided with DriveExecutive for more information on HIM Sets or using the HIM.
2. Read the [General Safety Precautions on page 9](#).
3. Remove power from the drive. See [Remove Power from the Drive on page 39](#).
4. Remove the protective covers from the drive. See [Remove the Protective Covers from the Drive on page 41](#).
5. Remove the communication adapter and EMI shield from the control board. See [Remove the Communication Adapter and EMI Shield on page 43](#).
6. If present, remove the I/O expansion circuit board. See [Remove the I/O Expansion Circuit Board on page 48](#).

7. If present, remove the 115V AC to 24V DC I/O converter circuit board. See [Remove the 115V AC to 24V DC I/O Converter Circuit Board on page 50](#).
8. Record all switch and jumper settings on the control board. Refer to the TPDflex DC Converters User Manual, publication 1S7TFLEXUM0 for more information.

IMPORTANT Mark all connections and wires before removal to avoid incorrect wiring during reassembly.

9. Carefully disconnect the cables from connectors XFGD, XA and XR on the control board.
10. Remove the plug-in I/O and control terminal blocks with the wiring kept in place.

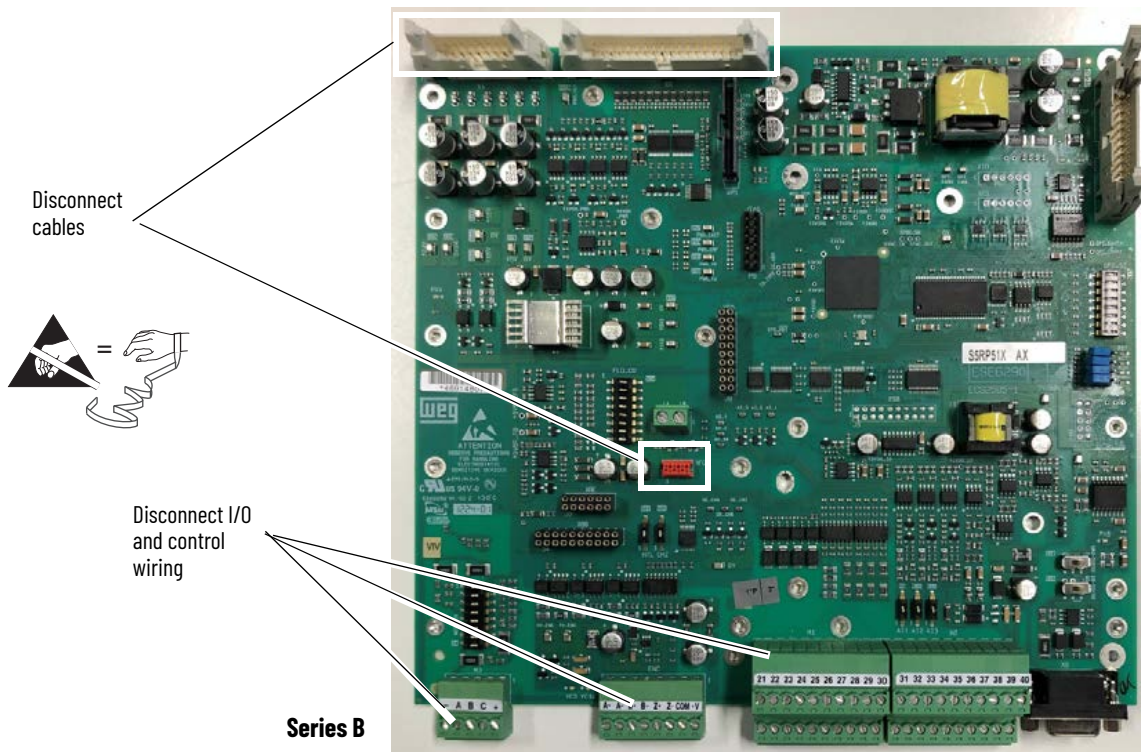
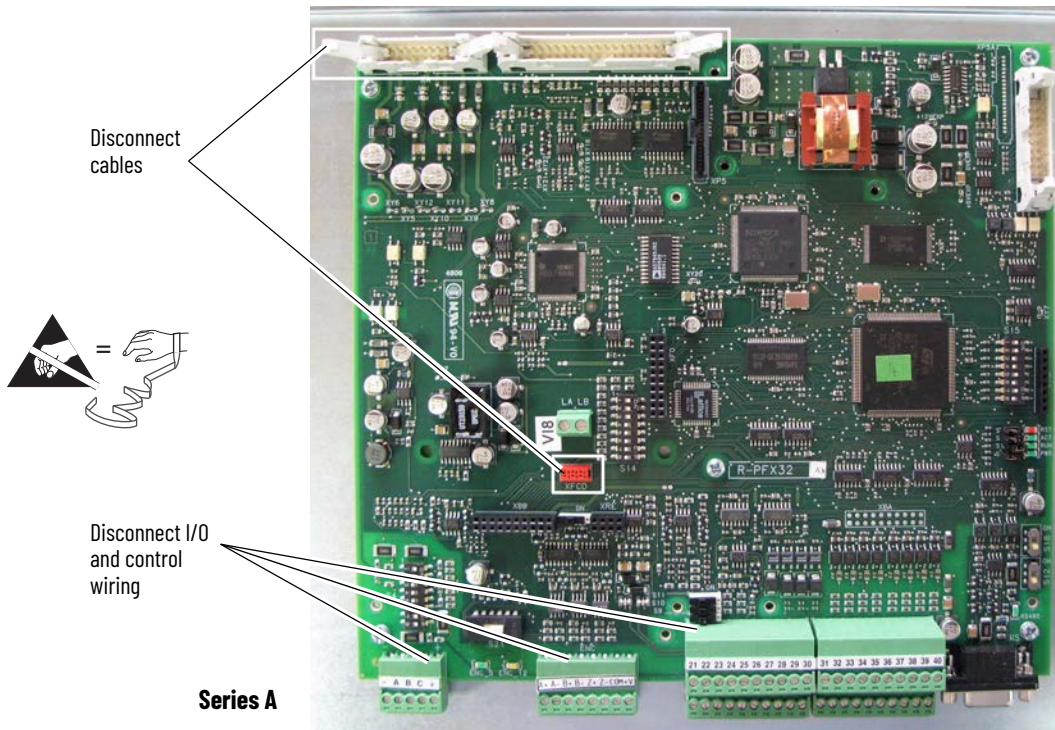

11. Remove the five screws that secure the control board to the control EMI shield and remove the board.

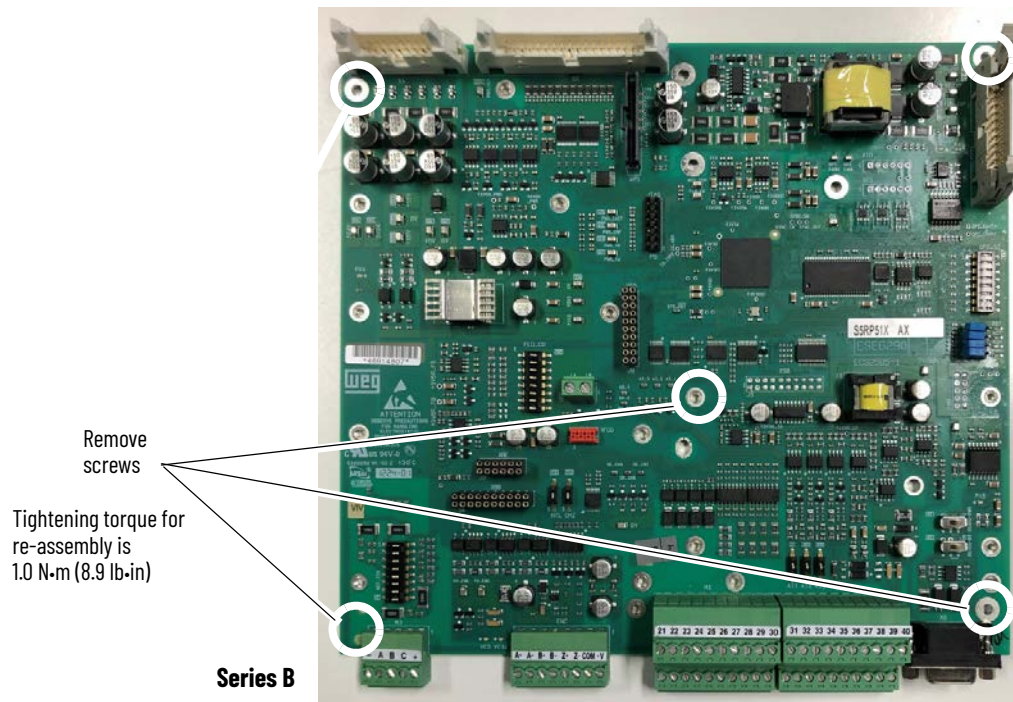
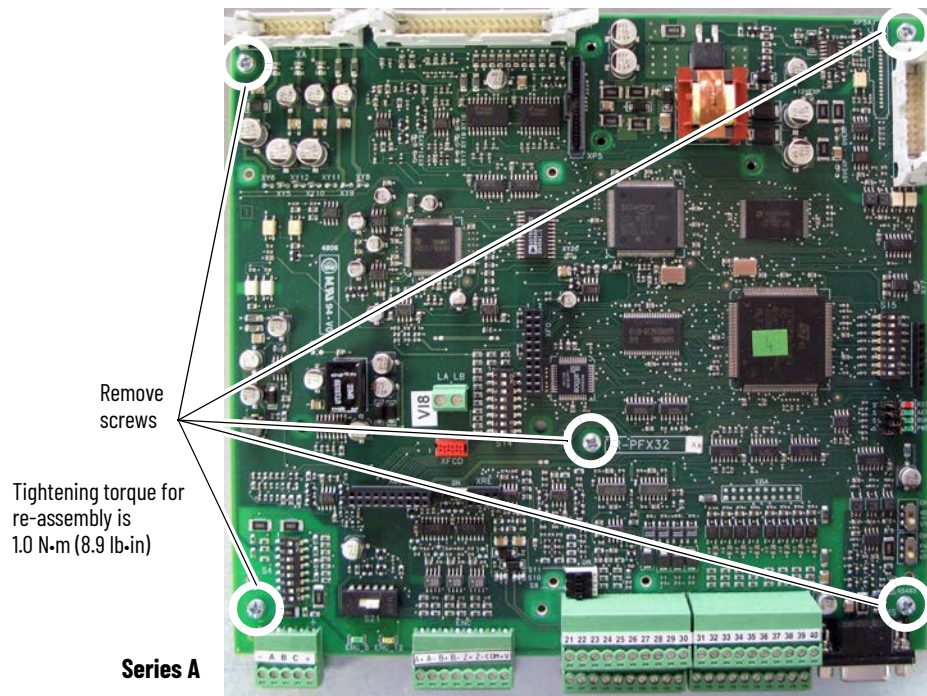

Install the Control Circuit Board

Install the control board in reverse order of removal.

Control EMI Shield Removal and Closure

Move the Control EMI Shield

You must move the control EMI shield that holds the control board in order to access other components within the drive.

1. Read the [General Safety Precautions on page 9](#).
2. Remove power from the drive. See [Remove Power from the Drive on page 39](#).
3. Remove the covers from the drive. See [Remove the Protective Covers from the Drive on page 41](#).
4. Carefully disconnect the cables from connectors XFC and XR on the control board.

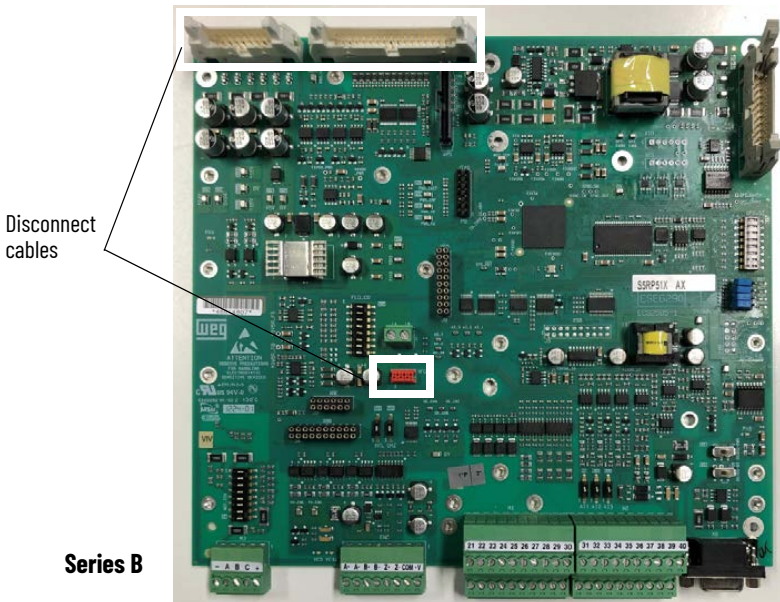
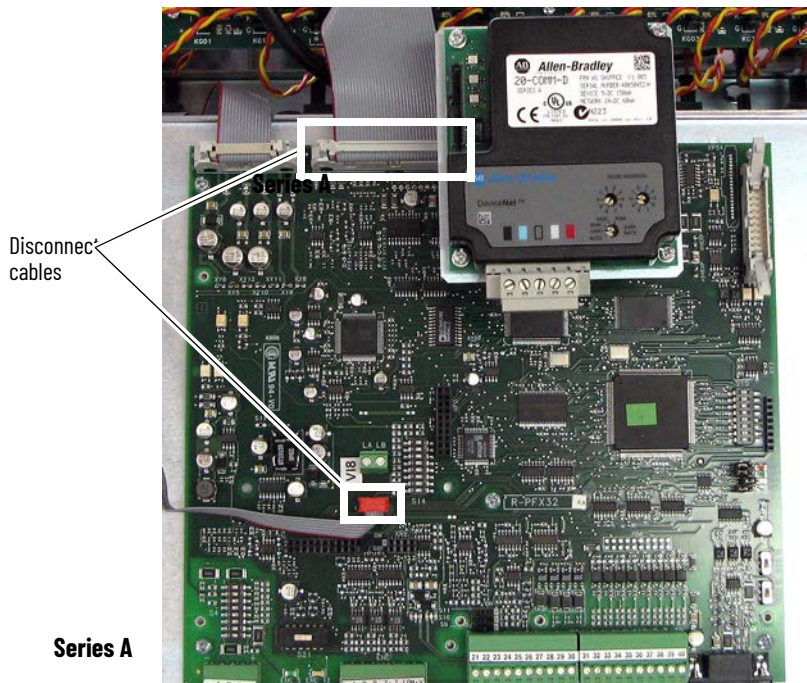

5. Loosen the two captive screws at the top of the control EMI shield and partially lower the shield. The shield will not open to its full extent due to a cable connection between the switching power supply board and the pulse transformer board.

Loosen screws

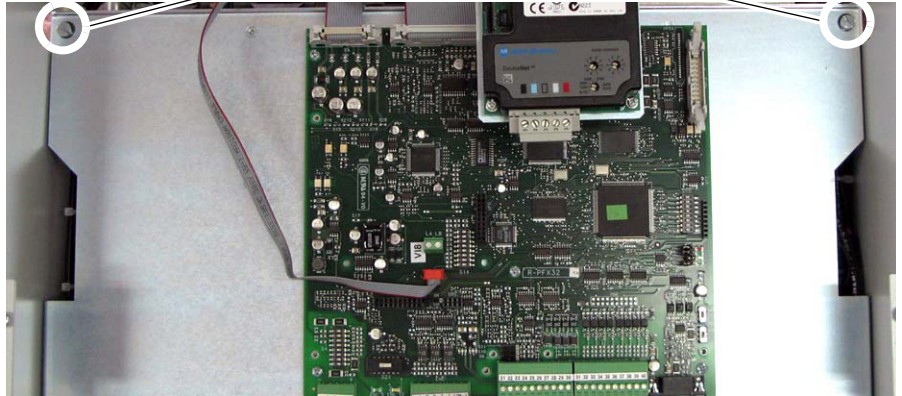

6. Disconnect the cable from connector XSW on the switching power supply board and lower the control EMI shield until it rests on the drive chassis.

IMPORTANT If the drive is not in a vertical position, the control EMI shield will not stay open without a means of restraint.

Remove cable

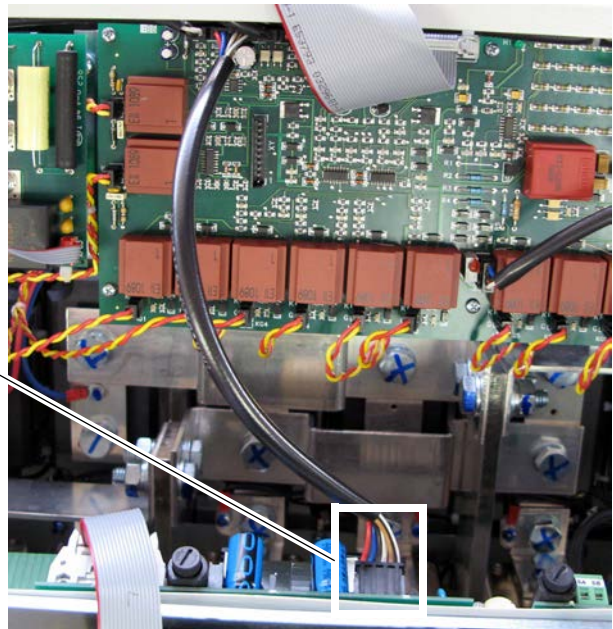

Install the Control EMI Shield

Install the control EMI shield in reverse order of removal.

Switching Power Supply Circuit Board Fuse Removal and Installation

Remove the Fuses on the Switching Power Supply Circuit Board

1. Read the [General Safety Precautions on page 9](#).
2. Remove power from the drive. See [Remove Power from the Drive on page 39](#).
3. Remove the covers from the drive. See [Remove the Protective Covers from the Drive on page 41](#).
4. Move the control EMI shield. See [Move the Control EMI Shield on page 54](#).
5. Remove the two fuses on the switching power supply board by inserting a screwdriver in the slot on the top of the fuse, carefully pushing down and turning the fuse counterclockwise. When the fuse holder releases, remove the holder and fuse.

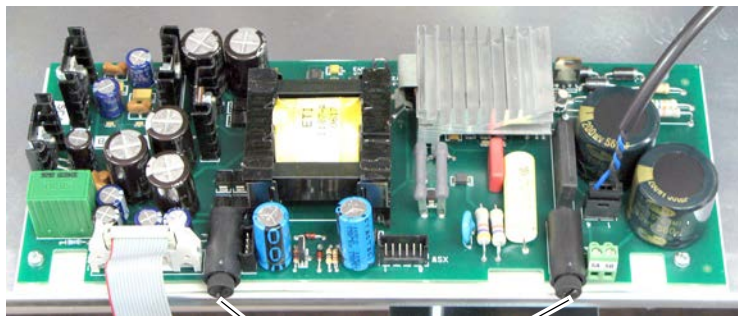

Remove fuses from holders

Install the Fuses on the Switching Power Supply Circuit Board

Install the fuses on the switching power supply board in reverse order of removal.

IMPORTANT Insert the 3.15A 250V fuse in the fuse holder designated F1. Insert the 2.5A 250V fuse in the fuse holder designated F2.



F1 3.15A
250V fuse

F2 2.5A
250V fuse

Switching Power Supply Circuit Board Removal and Installation

Remove the Switching Power Supply Circuit Board

1. Read the [General Safety Precautions on page 9](#).
2. Remove power from the drive. See [Remove Power from the Drive on page 39](#).
3. Remove the covers from the drive. See [Remove the Protective Covers from the Drive on page 41](#).
4. Move the control EMI shield. See [Move the Control EMI Shield on page 54](#).
5. Disconnect the cables from connector XA and XUV on the switching power supply board.

IMPORTANT Mark all connections and wires before removal to avoid incorrect wiring during reassembly.

6. If present, disconnect the jumper from terminals SA-SB.

IMPORTANT Be sure to replace the jumper between terminals SA-SB if using 115V AC control input power when installing a new switching power supply board.

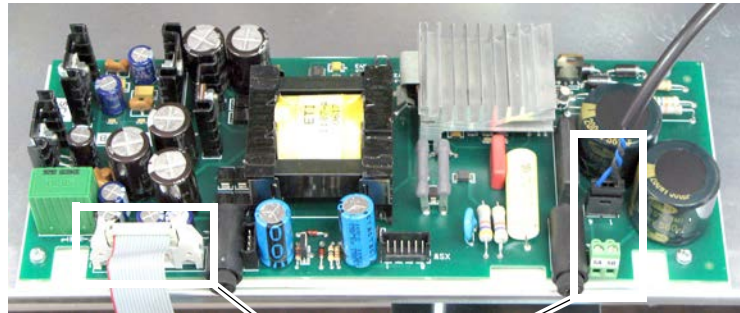

Disconnect cables and wiring

7. Remove the six screws and washers that secure the board to the control EMI shield and remove the board.

IMPORTANT DO NOT remove the isolation shield below the board, unless it is damaged and you are replacing it with a new sheet.

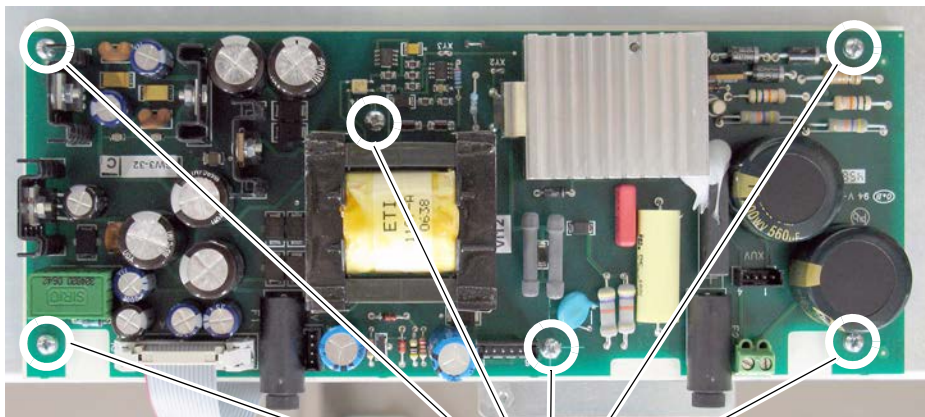

Remove six screws and washers

Install the Switching Power Supply Circuit Board

Install the switching power supply board in reverse order of removal.

Pulse Transformer Circuit Board Removal and Installation

Remove the Pulse Transformer Circuit Board

1. Read the [General Safety Precautions on page 9](#).
2. Remove power from the drive. See [Remove Power from the Drive on page 39](#).
3. Remove the covers from the drive. See [Remove the Protective Covers from the Drive on page 41](#).
4. Move the control EMI shield. See [Move the Control EMI Shield on page 54](#).
5. Remove the four screws (two on either side of the drive frame) that secure the slotted air flow plate to the top of the drive and remove the plate.

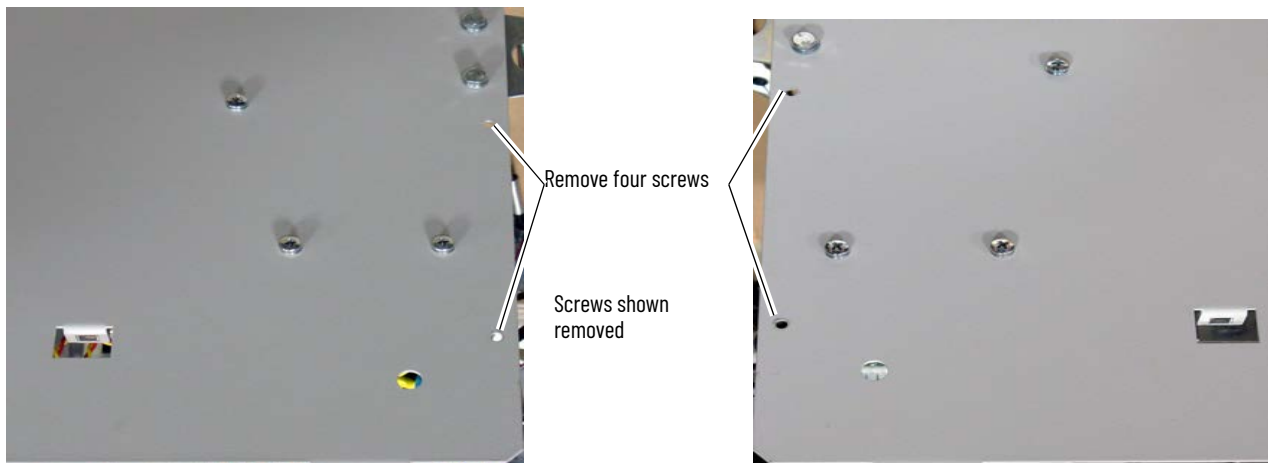
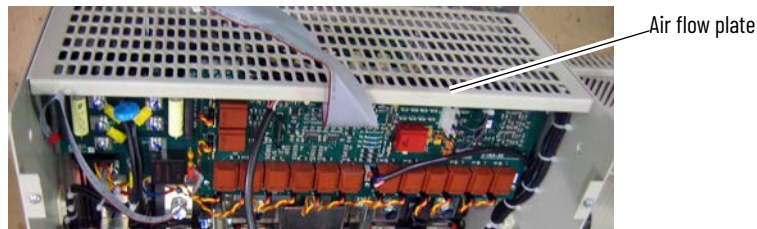

IMPORTANT Mark all connections and wires before removal to avoid incorrect wiring during reassembly.

6. Remove the appropriate gate leads:
 - For non-regenerative drives, remove each pair of (orange and yellow) gate lead cables from connectors KG1...KG6 and push each lead through the appropriate opening in the board.
 - For regenerative drive, remove each pair of (orange and yellow) gate lead cables from connectors KG01...KG06 and KG1...KG6 and push each lead through the appropriate opening in the board.

IMPORTANT Carefully remove the gate leads by grasping the connector. DO NOT pull the gate leads off by pulling on the wires.

7. Remove the cable from connector XTA at the bottom center of the board.

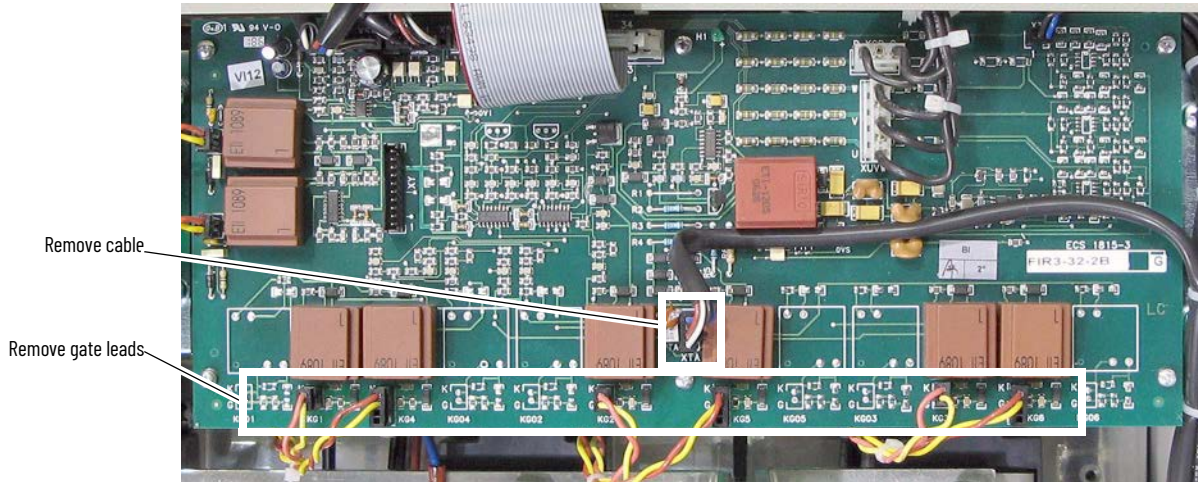
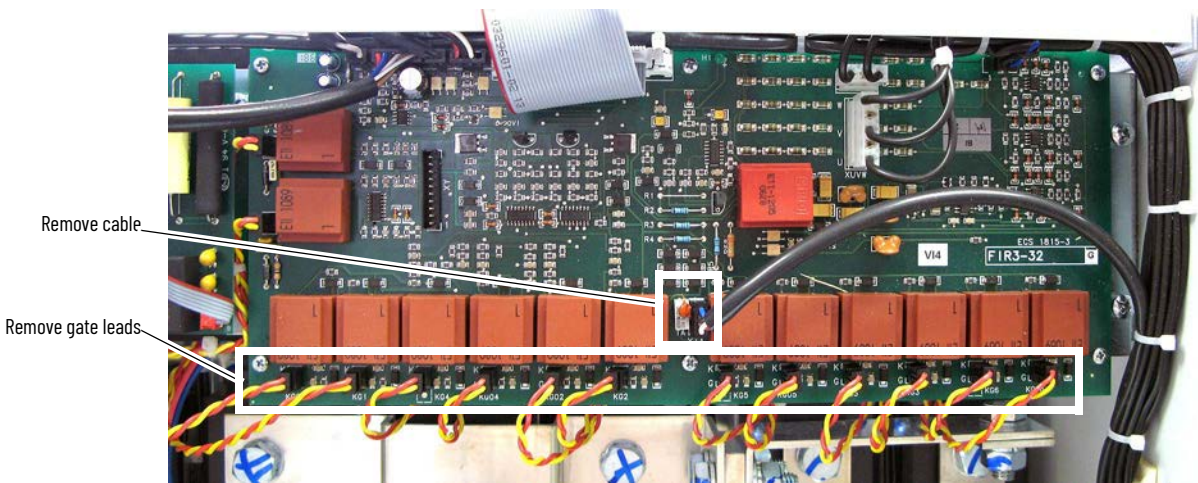
Non Regenerati e Dri e**Regenerati e Dri e**

8. Remove the (orange and yellow) cables from connectors K1G1 and K2G2 on the top left side of the board.
9. Remove the cables from connectors X4, X5 and XTM at the top left side of the board.

Remove cables

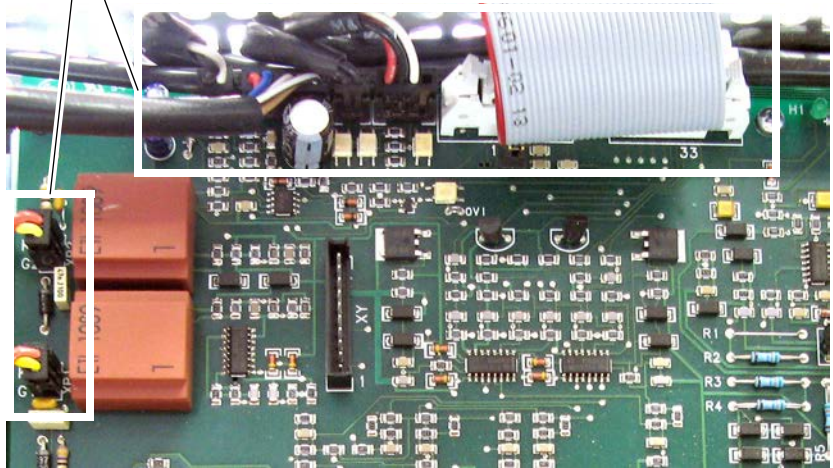

10. Remove the cables from connectors XCD, XUVW and X3 at the top right side of the board.

Remove cables

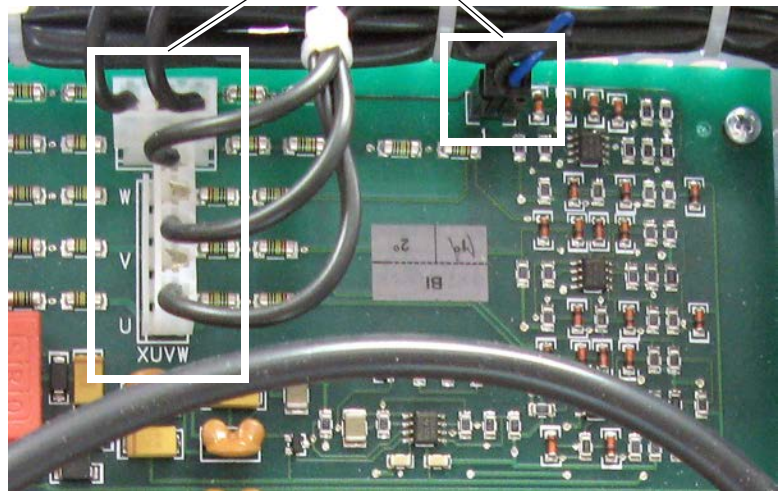

11. For Pulse Transformer boards with an armature voltage feedback terminal block, FIR3-XX, rev. "M" and higher, remove the cable from connector XCD_IO on the upper right corner of the board.

Remove cable from XCD_IO connector

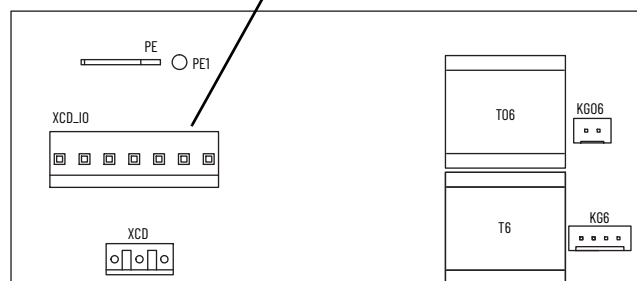

12. Remove the six screws and washers that secure the pulse transformer board to the drive and remove the board.

Remove screws and washers

Note Regenerati e Drive Shown

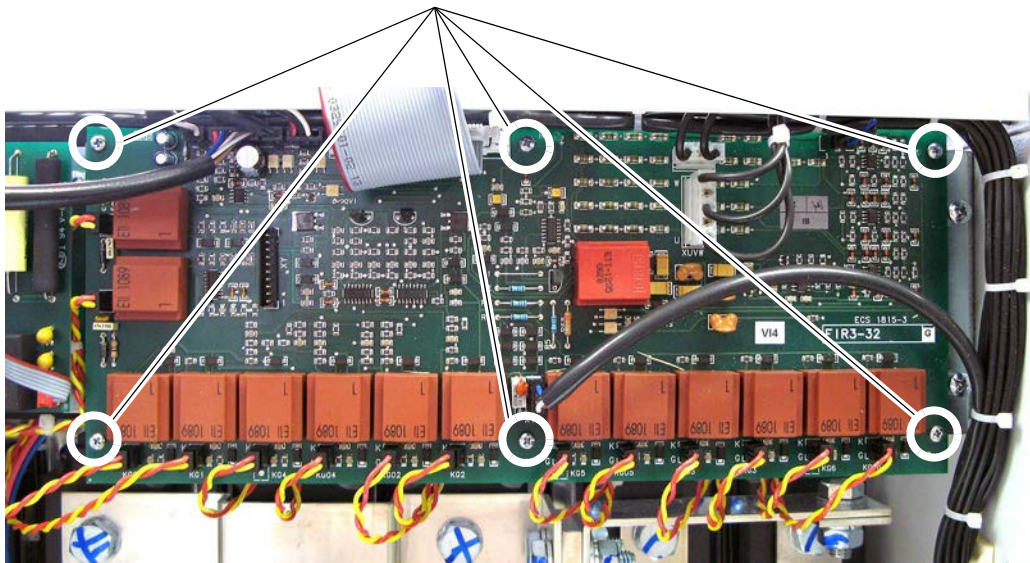

Configure the Pulse Transformer Circuit Board

The new pulse transformer circuit board must be configured to match the drive size (armature output current and HP rating). The steps required to configure the pulse transformer board are different based on the revision code of the pulse transformer board. See either, [Configuring a Pulse Transformer Board FIR3-xx Rev. "L" and Lower on page 61](#), or [Configuring a Pulse Transformer Board FIR3-xx Rev. "M" and Higher on page 64](#).

Configuring a Pulse Transformer Board FIR3-xx Rev. "L" and Lower

IMPORTANT This procedure requires a multimeter that measures resistance to thousandths of an ohm.

1. Cut and remove the appropriate sizing resistor(s) (if necessary) from the pulse transformer board based on the drive AC input voltage, armature output current, and HP rating shown in [Table 13](#) and [Table 14](#) in the Sizing Resistors Configuration section below.

Sizing resistors are located in the center of the pulse transformer circuit board.

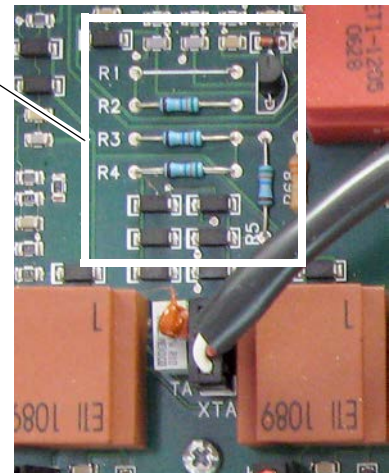

Sizing Resistors Configuration

The tables below indicate the value of the designated resistor (R1...R5) when left in place on the pulse transformer board, or indicate "Remove" when the resistor should be cut off and removed from the board. "-" indicates that this resistor is not contained on the pulse transformer board for the designated drive size.

Table 13 - 230V AC Input Drives

Drive Current Rating Code	DC Amps	AC Line Amps	HP	R1	R2	R3	R4	R5
521	521	426	150	-	Remove	5.36Ω	5.36Ω	5.36Ω

Table 14 - 460V AC Input Drives

Drive Current Rating Code	DC Amps	AC Line Amps	HP	R1	R2	R3	R4	R5
495	495	404.4	300	-	Remove	5.36Ω	5.36Ω	5.36Ω
667	667	544.9	400	-	5.36Ω	5.36Ω	5.36Ω	5.36Ω

2. Connect the leads of the multimeter to pins 13 and 14 of connector XR on the pulse transformer board (polarity is not important) and, using the TA potentiometer in the center of the pulse transformer circuit board, set the total resistance (RTA) to the appropriate value as indicated in [Table 15](#) or [Table 16](#) in the [Total Resistance Values](#) section on [page 63](#).

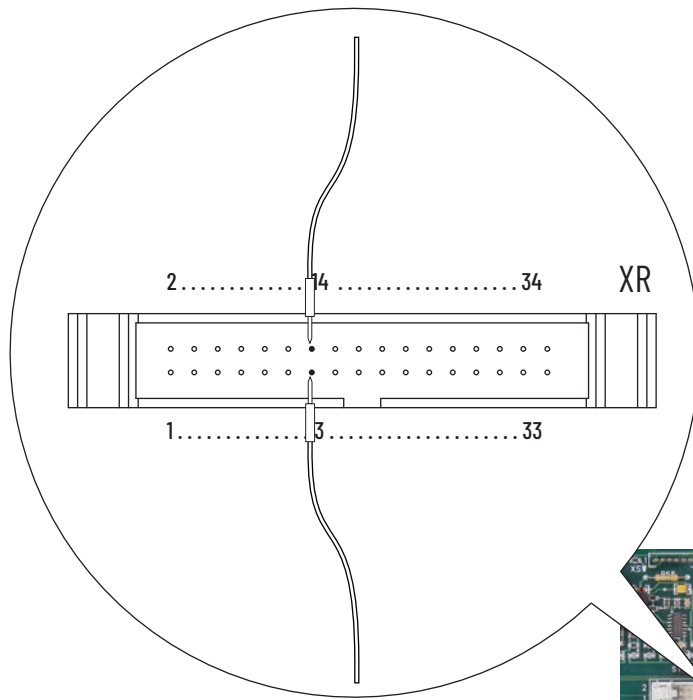

The XR connector is located on the upper right corner of the pulse transformer circuit board.

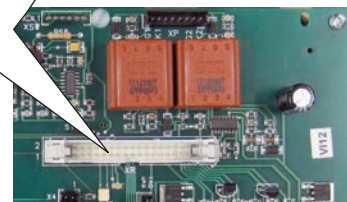

The TA potentiometer is located on the lower right corner of the pulse transformer circuit board next to the control power terminal block.

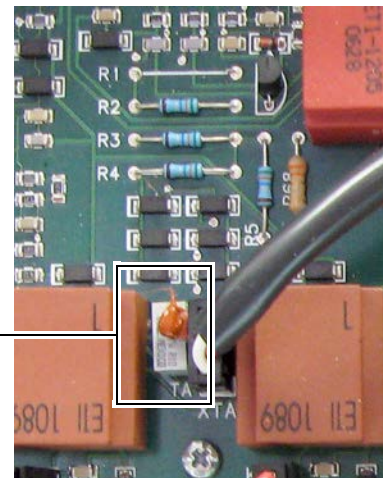

Total Resistance values

Table 15 - 230V AC Input Drives

Drive Current Rating Code	DC Amps	AC Line Amps	HP	Set RTA Value Using TA Potentiometer (Ohms)
521	521	426	150	4.699

Table 16 - 460V AC Input Drives

Drive Current Rating Code	DC Amps	AC Line Amps	HP	Set RTA Value Using TA Potentiometer (Ohms)
495	495	404.4	300	4.945
667	667	544.9	400	3.67

3. Seal the TA potentiometer in place using RV (silicon).
4. Continue with [Install the Pulse Transformer Circuit Board on page 65](#).

Configuring a Pulse Transformer Board FIR3-xx Rev. "M" and Higher

Set DIP switches S3 and S4 (shown in the illustration below) on the pulse transformer board to the correct settings based on the appropriate AC input voltage, armature output current, and HP rating shown in [Table 17](#) or [Table 18](#) on page 64.

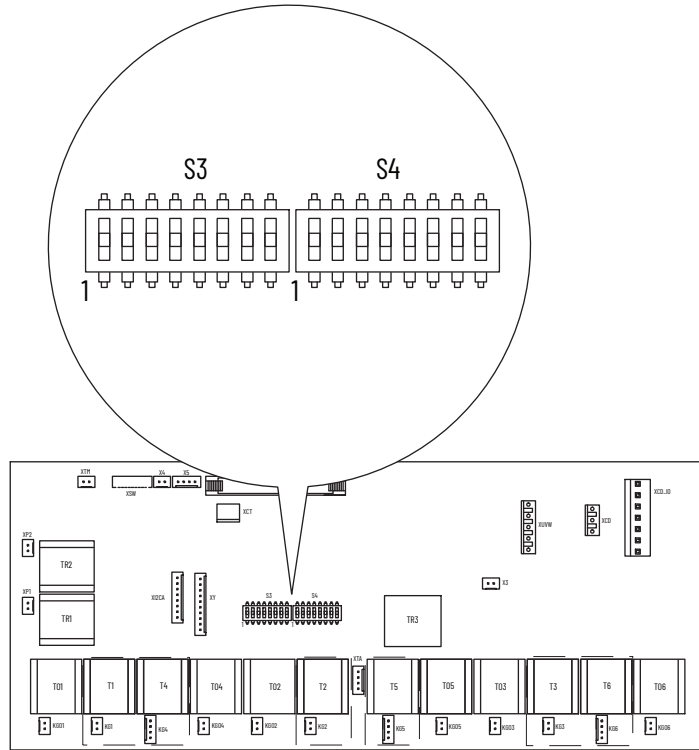

IMPORTANT A blank cell below a switch in the tables below indicate that the setting is "OFF".

Table 17 - 230V AC Input Drives

Drive Current Rating Code	DC Amps	AC Line Amps	HP	DIP Switch S3								DIP Switch S4							
				S3 1	S3 2	S3 3	S3 4	S3 5	S3 6	S3 7	S3 8	S4 1	S4 2	S4 3	S4 4	S4 5	S4 6	S4 7	S4 8
521	521	426	150	ON			ON							ON			ON		
70	700	571	200							ON		ON				ON	ON		

Table 18 - 460V AC Input Drives

Drive Current Rating Code	DC Amps	AC Line Amps	HP	DIP Switch S3								DIP Switch S4							
				S3 1	S3 2	S3 3	S3 4	S3 5	S3 6	S3 7	S3 8	S4 1	S4 2	S4 3	S4 4	S4 5	S4 6	S4 7	S4 8
495	495	404.4	300		ON		ON						ON				ON		
667	667	544.9	400							ON	ON					ON	ON		

Table 19 - 575V AC Input Drives

Drive Current Rating Code	DC Amps	AC Line Amps	HP	DIP Switch S3								DIP Switch S4							
				S3 1	S3 2	S3 3	S3 4	S3 5	S3 6	S3 7	S3 8	S4 1	S4 2	S4 3	S4 4	S4 5	S4 6	S4 7	S4 8
540	540	441.2	400					ON			ON			ON			ON		
675	675	551.5	500	ON								ON				ON	ON		

Table 20 - 690V AC Input Drives

Drive Current Rating Code	DC Amps	AC Line Amps	HP	DIP Switch S3								DIP Switch S4							
				S3 1	S3 2	S3 3	S3 4	S3 5	S3 6	S3 7	S3 8	S4 1	S4 2	S4 3	S4 4	S4 5	S4 6	S4 7	S4 8
452	452	369	400	ON	ON						ON							ON	
565	565	462	500	ON									ON		ON				ON

Install the Pulse Transformer Circuit Board

Install the new pulse transformer board in reverse order of removal.

- Inspect the existing connection cables for burn marks, cracks or loose connectors. If necessary, replace the cables connected to connector X3, X4, X5, XCD, XR, XSW, XTA and XUVW on the pulse transformer board with the new cables provided.
- Inspect the existing gate lead cables for burn marks, cracks or loose connectors. If necessary, replace the gate lead cables with the new cables provided.



ATTENTION Each gate lead cable must be connected to the exact connector from which it was removed on the pulse transformer circuit board or damage to the drive may occur.

Field Power Circuit Board Removal and Installation

Remove the Field Power Circuit Board

1. Read the [General Safety Precautions on page 9](#).
2. Remove power from the drive. See [Remove Power from the Drive on page 39](#).
3. Remove the covers from the drive. See [Remove the Protective Covers from the Drive on page 41](#).
4. Move the control EMI shield. See [Move the Control EMI Shield on page 54](#).

IMPORTANT Mark all connections and wires before removal to avoid incorrect wiring during reassembly.

5. Remove the cables from connectors X3 and XFCD on the board.
6. Remove the seven screws, washers and wire leads (connections 2V1, 2U1 and 2C1 and one unmarked) from the board and remove the board from the drive.

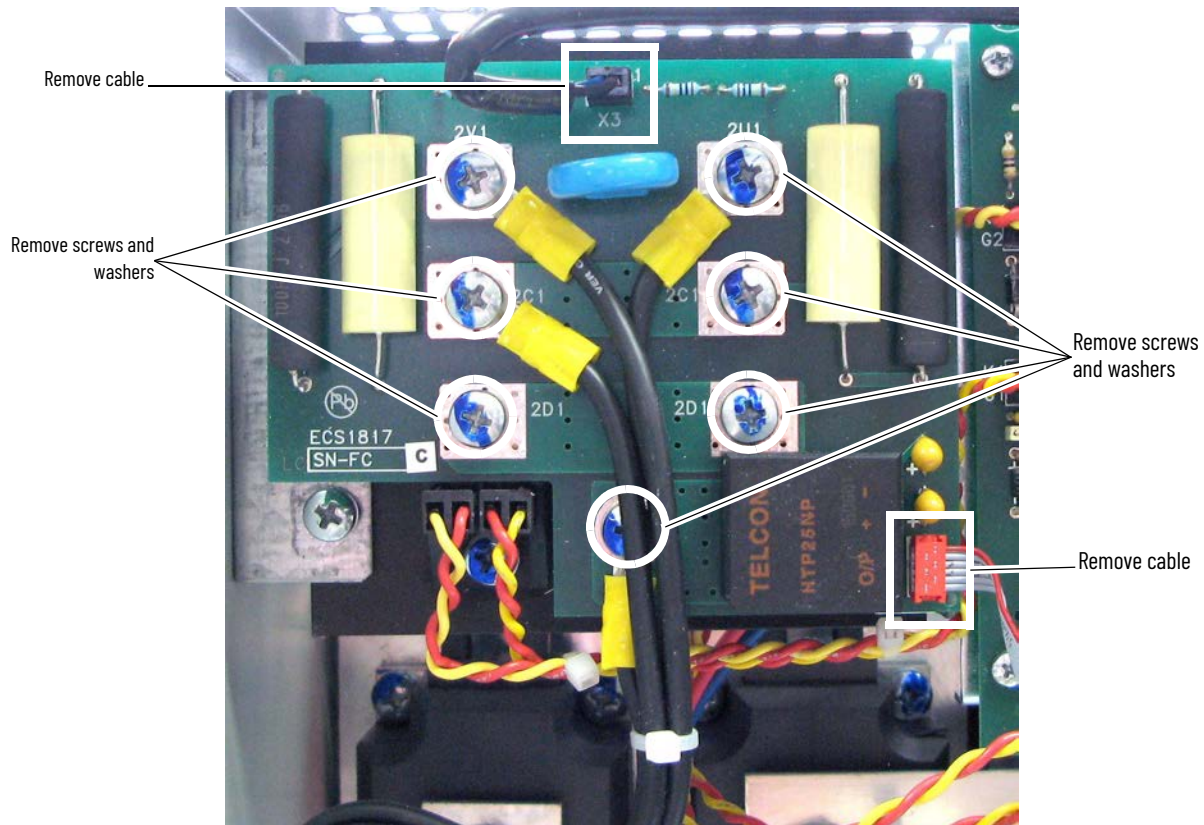

Install the Field Power Circuit Board

Install the field power board in reverse order of removal.

- Tightening torque for the screws connecting the field power board to the field SCR and dual diode modules is 2.5...4.0 N·m (22...35 lb-in).

Field SCR and Dual Diode Module Removal and Installation

Remove the Field SCR and Dual Diode Module

1. Read the [General Safety Precautions on page 9](#).
2. Remove power from the drive. See [Remove Power from the Drive on page 39](#).
3. Remove the covers from the drive. See [Remove the Protective Covers from the Drive on page 41](#).
4. Move the control EMI shield. See [Move the Control EMI Shield on page 54](#).
5. Remove the field power circuit board. See [Remove the Field Power Circuit Board on page 65](#).

IMPORTANT Mark all connections and wires before removal to avoid incorrect wiring during reassembly.

6. Remove the (orange and yellow) cables from connectors K1G1 and K2G2 on the top left side of the pulse transformer board.

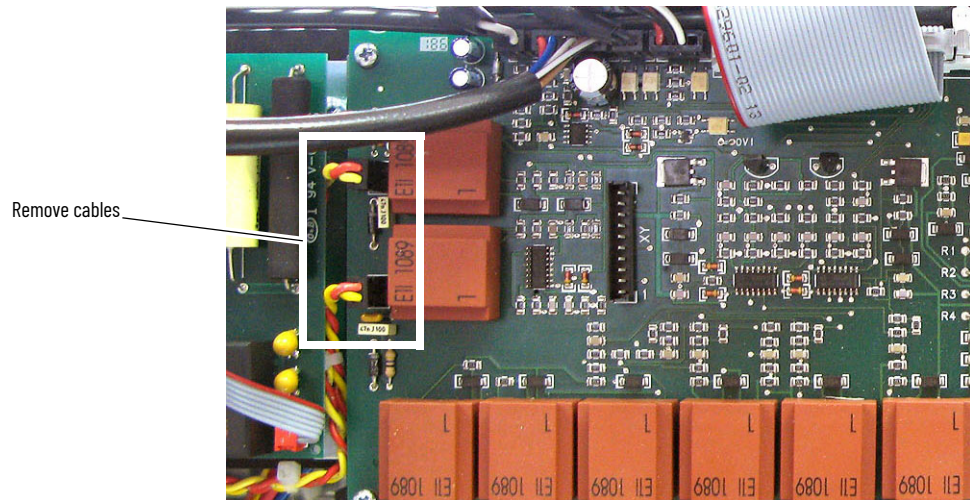

7. Remove the two screws and washers that secure each module to the heatsink and remove the modules from the drive.

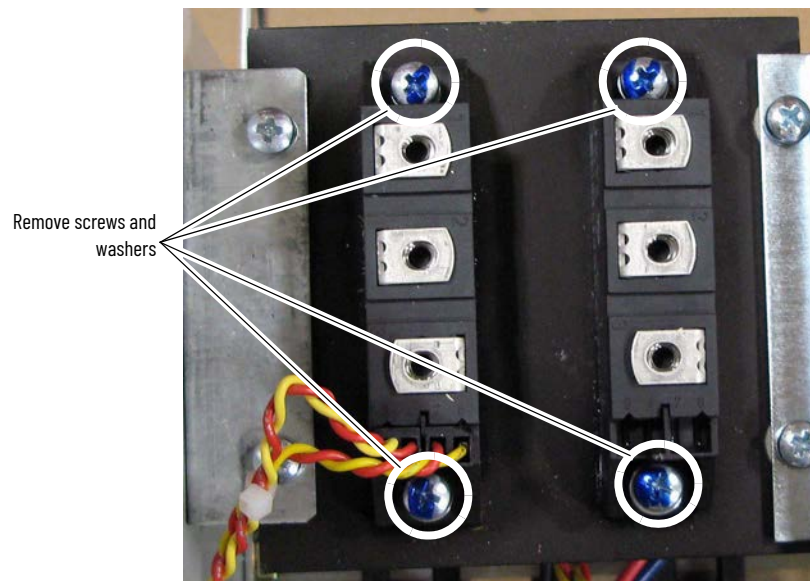

Install the Field SCR and Dual Diode Module

Install the field SCR and dual diode module in reverse order of removal.

- Apply thermal grease to the bottom of the SCR and dual diode modules before securing them to the heatsink.



ATTENTION Thermal grease must be applied to the bottom of the SCR and dual diode modules before securing them to the heatsink or damage to the drive may occur.

- Tightening torque for the screws connecting the field SCR and dual diode modules to the heatsink and the screws connecting the field board to the field SCR and dual diode modules is 2.5...4.0 N•m (22...35 lb•in).

AC Line Snubber Circuit Board and Resistors Removal and Installation

Remove the AC Line Snubber Circuit Board and Resistors

1. Read the [General Safety Precautions on page 9](#).
2. Remove power from the drive. See [Remove Power from the Drive on page 39](#).
3. Remove the covers from the drive. See [Remove the Protective Covers from the Drive on page 41](#).
4. Move the control EMI shield. See [Move the Control EMI Shield on page 54](#).

Disconnect and Remove the Pulse Transformer and Field Power Circuit Boards

You must remove the pulse transformer and field power circuit boards in order to replace the AC line snubber circuit board and resistors.

1. Remove the four screws that secure the slotted air flow plate to the top of the drive and remove the plate.

IMPORTANT Mark all connections and wires before removal to avoid incorrect wiring during reassembly.

2. Remove the appropriate gate leads:
 - For non-regenerative drives, remove each pair of (orange and yellow) gate lead cables from connectors KG1...KG6 and push each lead through the appropriate opening in the board.
 - For regenerative drive, remove each pair of (orange and yellow) gate lead cables from connectors KG01...KG06 and KG1...KG6 and push each lead through the appropriate opening in the board.

IMPORTANT Carefully remove the gate leads by grasping the connector. DO NOT pull the gate leads off by pulling on the wires.

3. Remove the cable from connector XTA at the bottom center of the pulse transformer board.

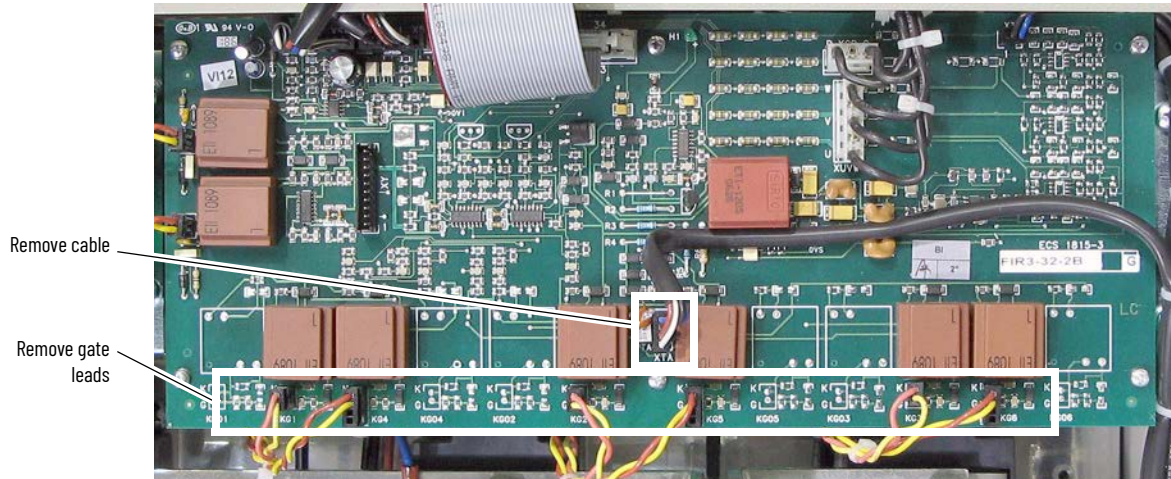
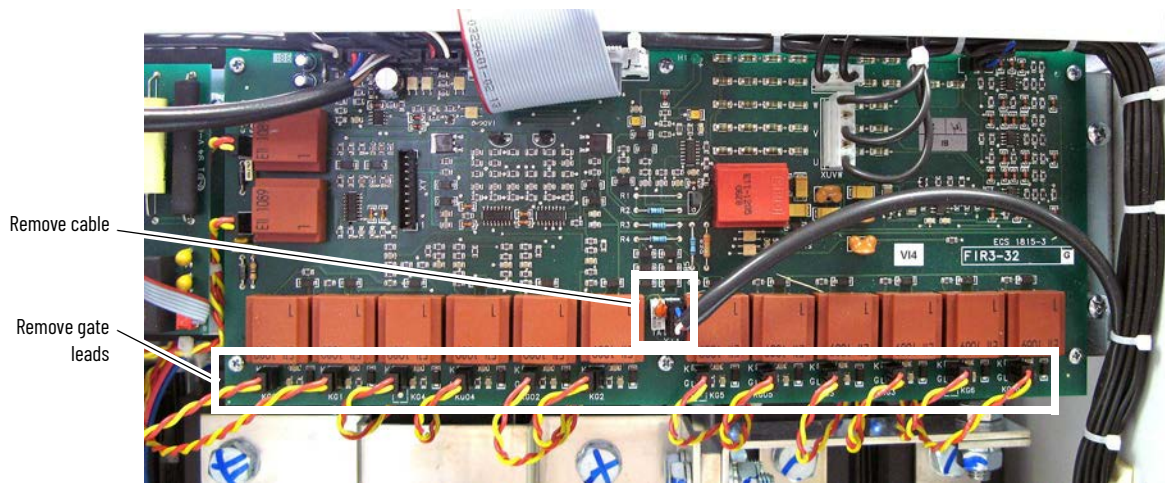
Non Regenerative Drive**Regenerative Drive**

4. Remove the (orange and yellow) cables from connectors K1G1 and K2G2 on the top left side of the pulse transformer board.
5. Remove the cables from connectors XTM, X4 and X5 at the top left side of the pulse transformer board.

Remove cables

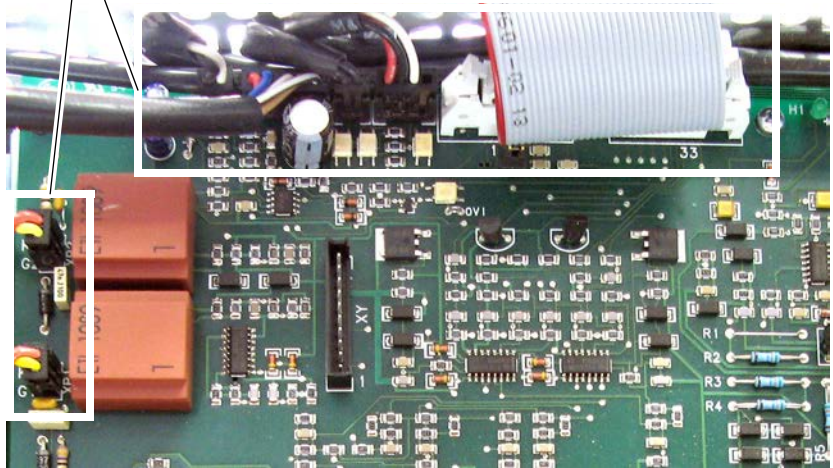

6. Remove the cables from connectors XCD, XUVW and X3 at the top right side of the pulse transformer board.

Remove cables

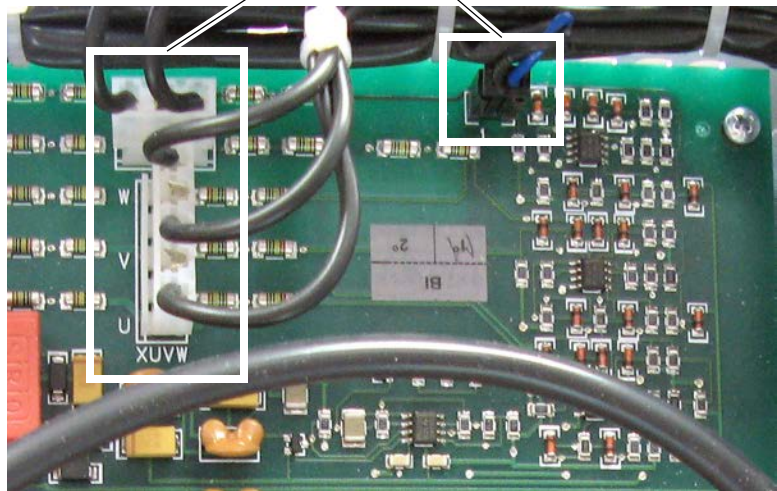

7. Remove the cables from connectors X3 and XFCD on the field power board.
8. Remove the four screws and washers that secure the wire leads (connections 2V1, 2U1 and 2C1 and one unmarked) from the field power board and set the wires aside.

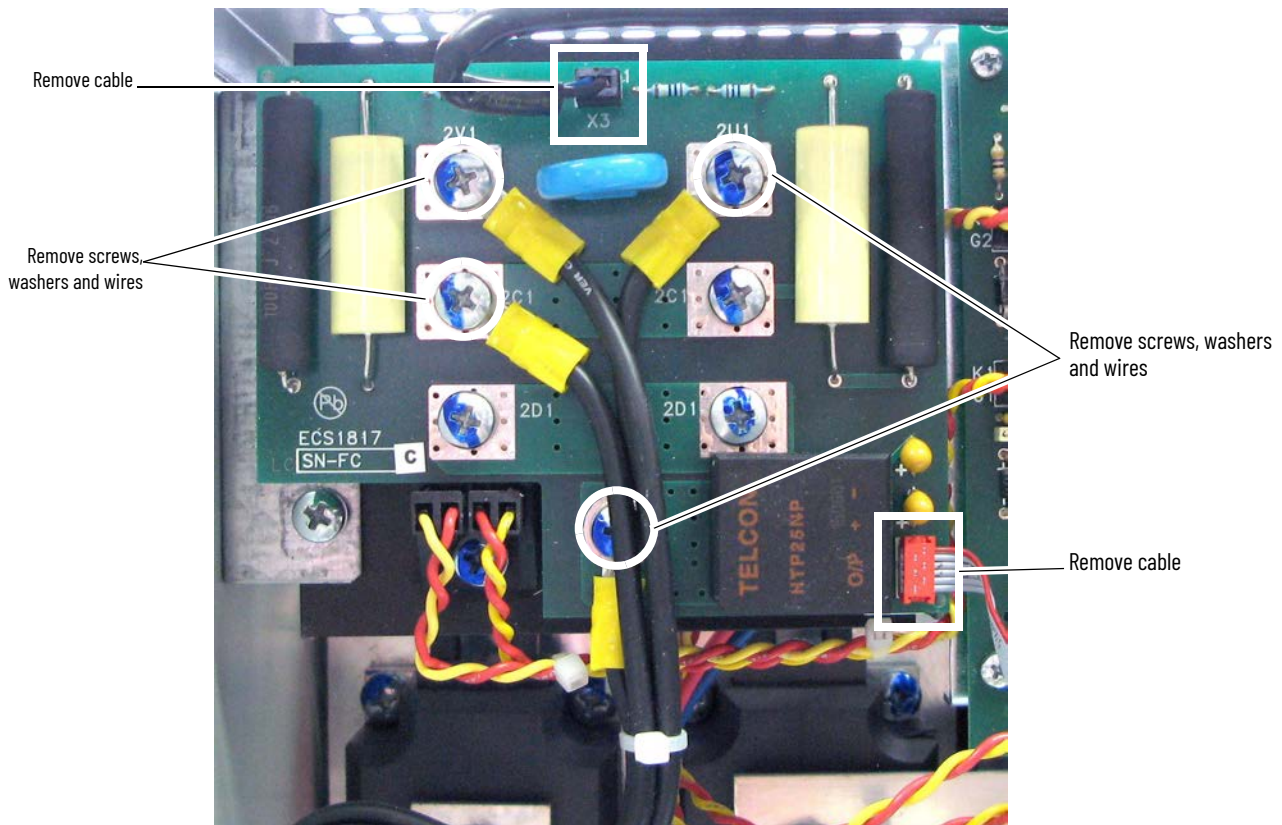

9. Remove the four screws and washers (two on either side of the drive frame) that secure the support plate for the pulse transformer and field power boards to the drive frame and remove the support plate and boards.

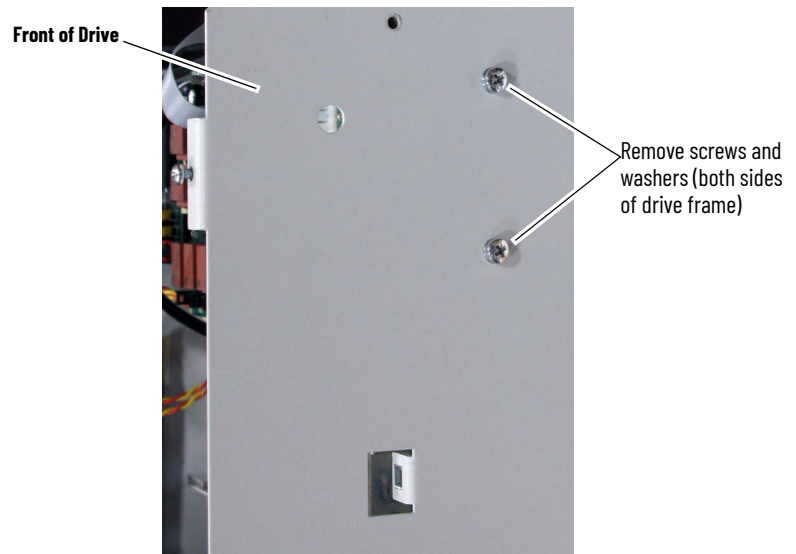

10. If present, remove the isolation sheet that is secured to the bus bars.

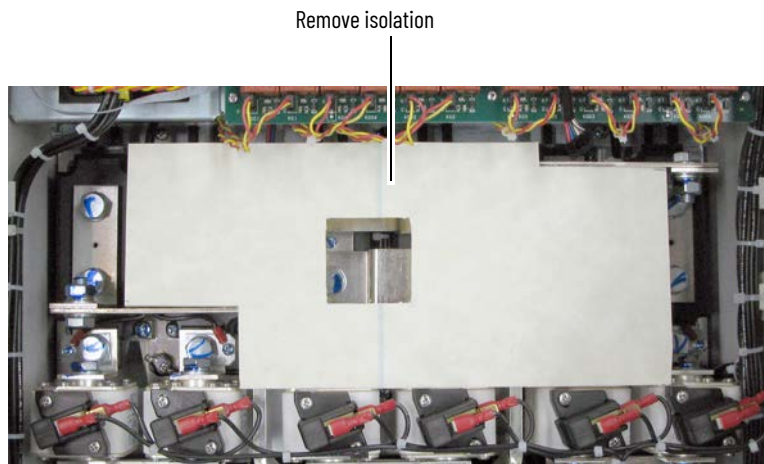

11. Remove the bolts and washers that secure the AC line snubber board (red and blue) leads and screws and washers that secure the resistor (black) leads to the bus bars and remove the leads.

Regenerative Drive

Remove bolts and washers

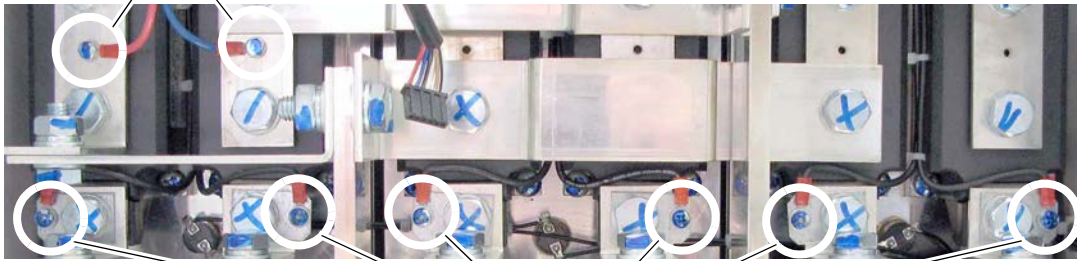

Remove screws and washers

Non Regenerative Drive

Remove bolts and washers

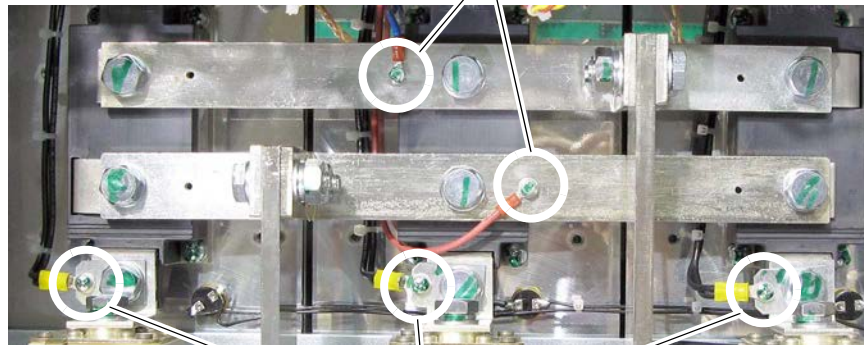

Remove screws and washers

12. Remove the three screws and washers that secure the AC line snubber board to the drive frame and remove the board.

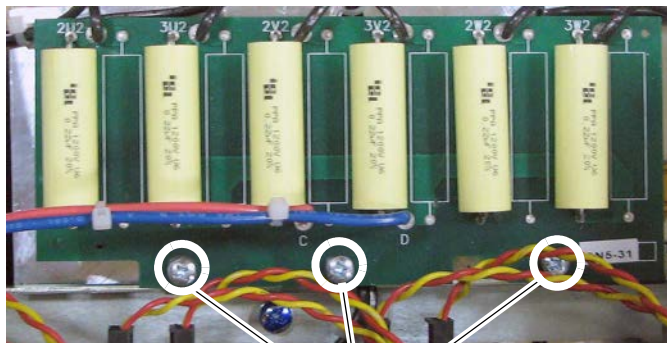

Remove screws and washers

13. Remove the two screws that secure each resistor (six total) to the drive frame and remove the resistors from the drive.

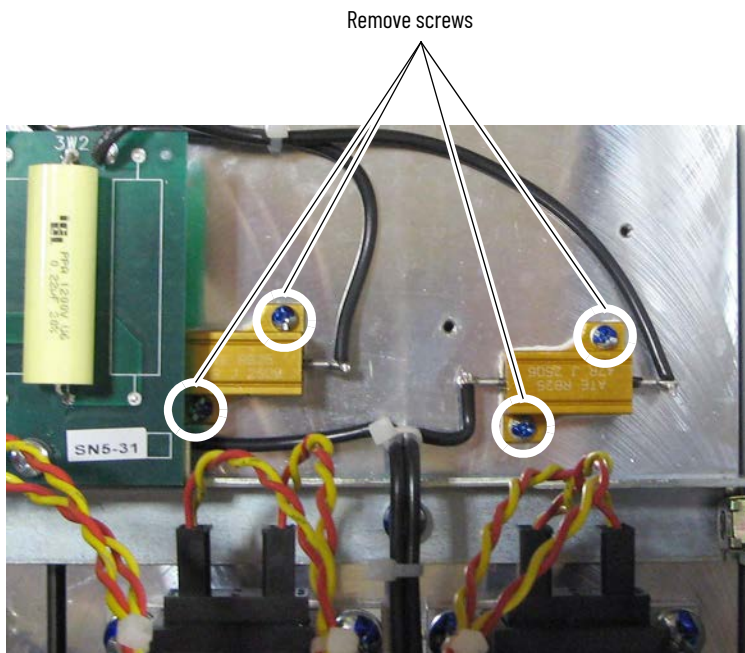

Install the AC Line Snubber Circuit Board and Resistors

Install the AC line snubber board and resistors in reverse order of removal.

- Apply thermal grease to the bottom of the resistors before securing them to the heatsink.



ATTENTION Thermal grease must be applied to the bottom of the resistors before securing them to the heatsink or damage to the drive may occur.

- Tightening torque for the screws connecting the field board to the field SCR and dual diode modules is 2.5...4.0 N·m (22...35 lb·in).

Transient Noise Filter Circuit Board Fuses Removal and Installation

Remove the Fuses on the Transient Noise Filter Circuit Board

1. Read the [General Safety Precautions on page 9](#).
2. Remove power from the drive. See [Remove Power from the Drive on page 39](#).
3. Remove the covers from the drive. See [Remove the Protective Covers from the Drive on page 41](#).
4. Move the control EMI shield. See [Move the Control EMI Shield on page 54](#).
5. Carefully remove the three fuses from the fuse holders on the transient noise filter board.

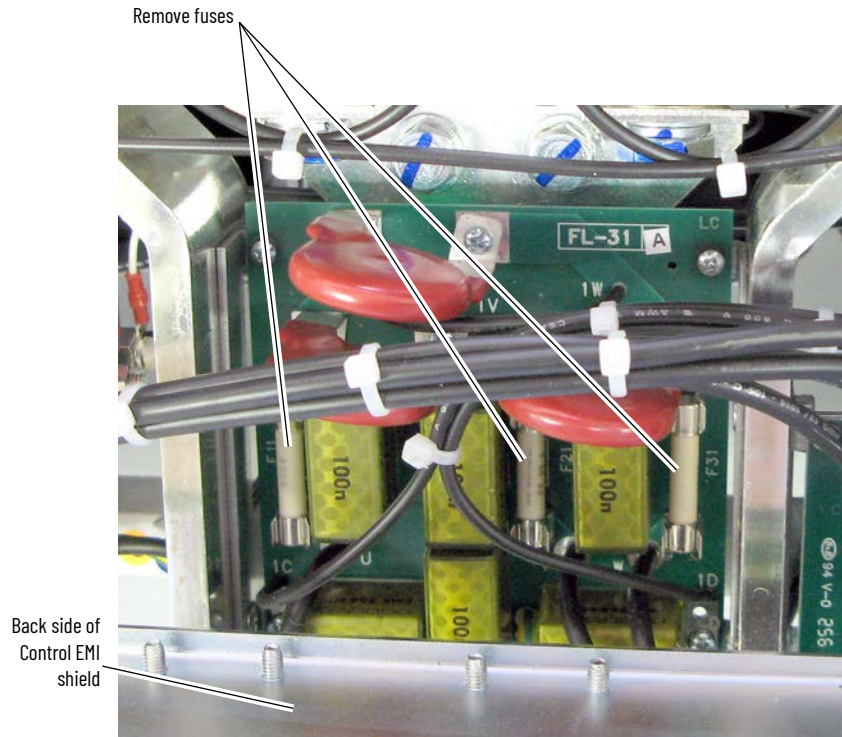

Install the Fuses on the Transient Noise Filter Circuit Board

Install the fuses on the transient noise filter board in reverse order of removal.

Transient Noise Filter Circuit Board Removal and Installation

Remove the Transient Noise Filter Circuit Board

1. Read the [General Safety Precautions on page 9](#).
2. Remove power from the drive. See [Remove Power from the Drive on page 39](#).
3. Remove the covers from the drive. See [Remove the Protective Covers from the Drive on page 41](#).

IMPORTANT Mark all connections and wires before removal to avoid incorrect wiring during reassembly.

4. Remove the ground wire from the PE ground stud on the drive frame.
5. Remove the screw that secures the black lead from connection U on the transient noise filter board to the U phase power terminal, and remove the lead.

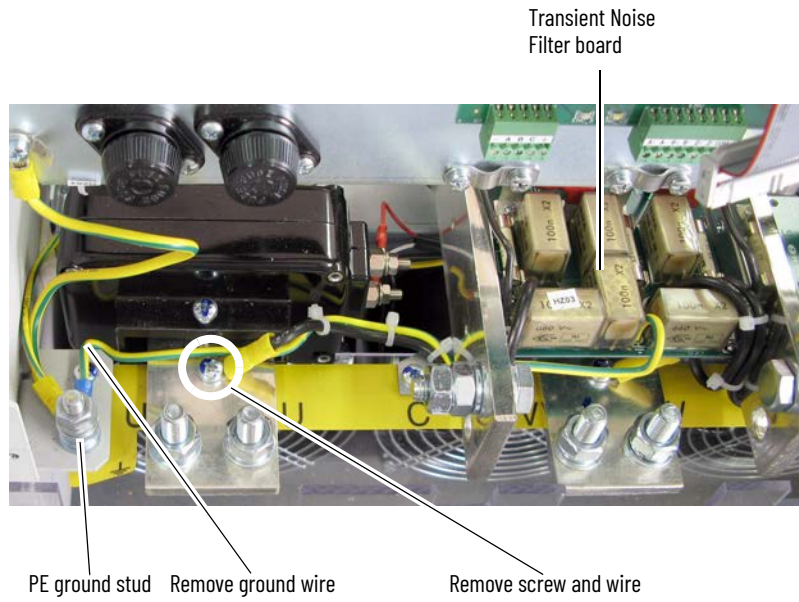

6. Remove the two screws and washers that secure the bottom of the transient noise filter board to the drive

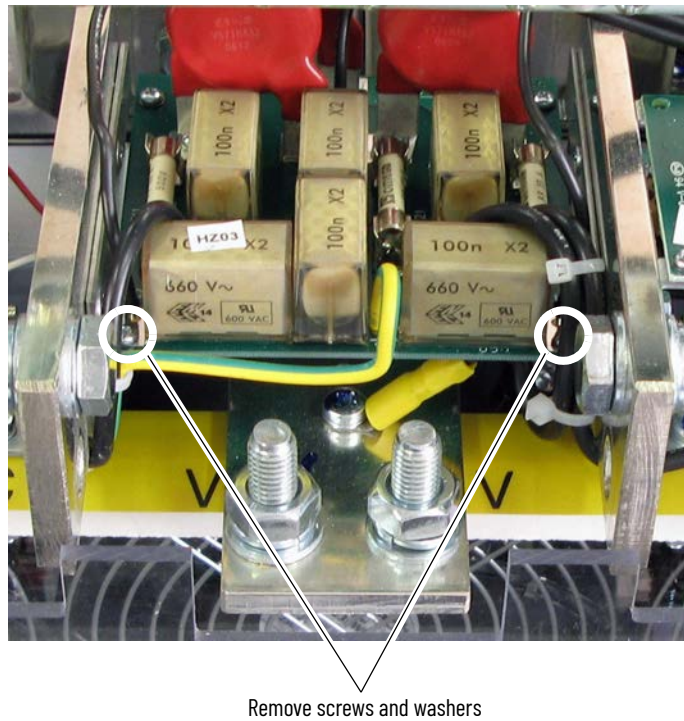

7. Remove the two screws and washers that secure the bottom of the power supply filter circuit board to the drive.



Remove screws and

8. Move the control EMI shield. See [Move the Control EMI Shield on page 54](#).
9. Remove the wires that connect to the back of the control terminals on the power supply filter board.
10. Remove the two screws and washers that secure the top of the power supply filter board to the drive and carefully lift the board.

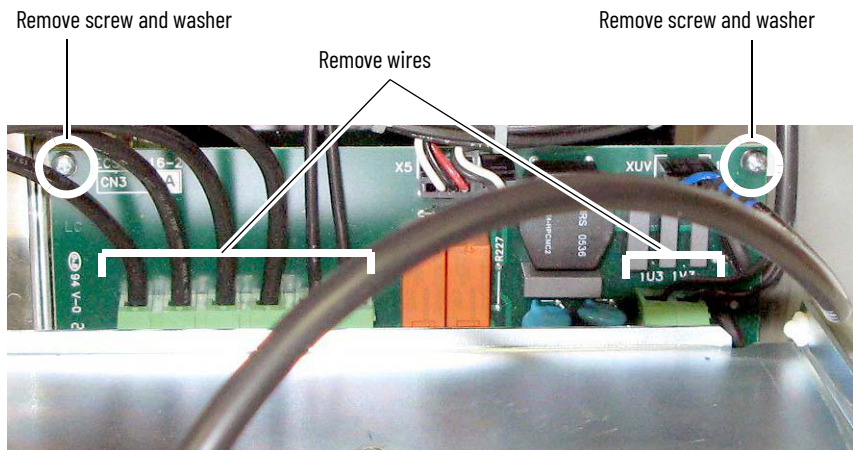

11. Remove the two screws and washers that secure the top of the transient noise filter board to the drive and carefully lift the board off the drive.

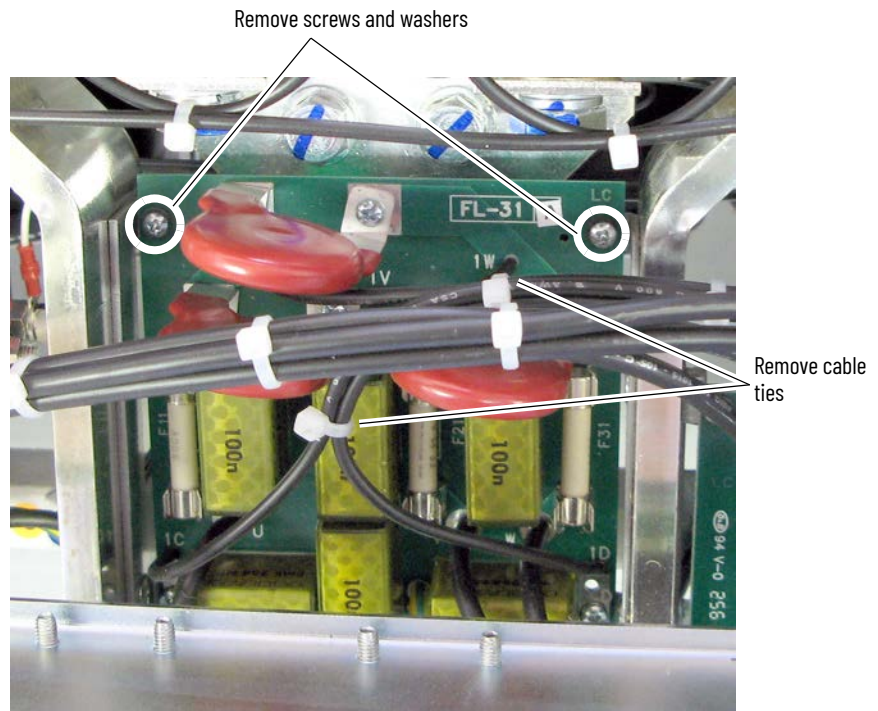

12. Remove the screws and washers that secure the black leads from connections V and W on the transient noise filter board to power terminals V and W, respectively, and remove the leads.

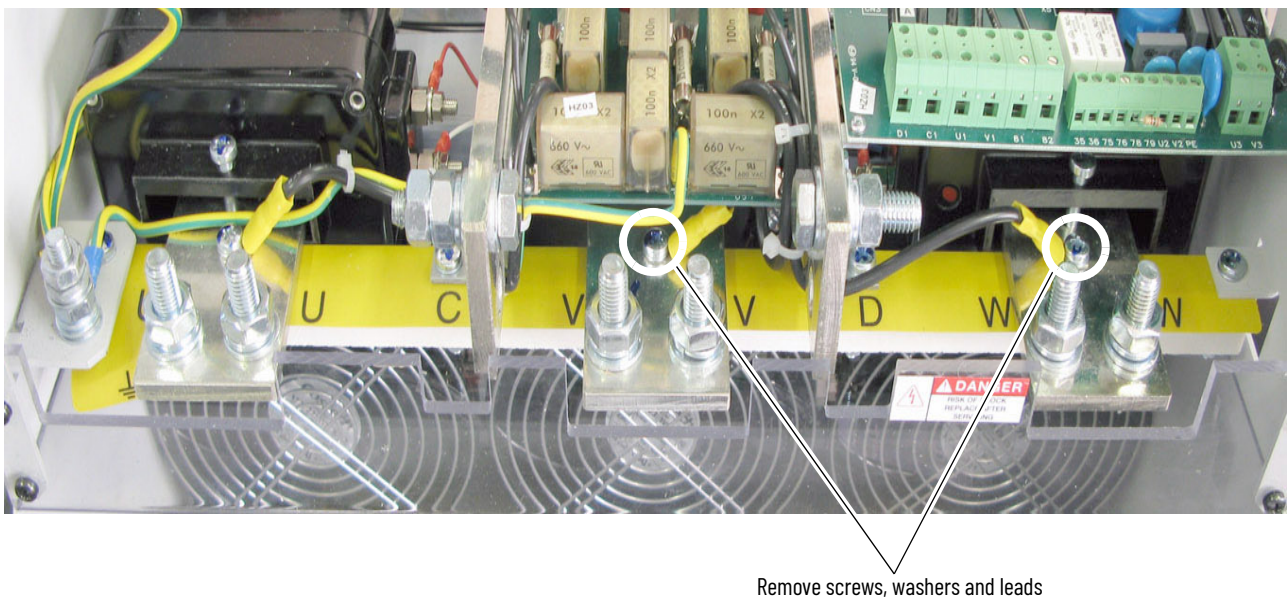

13. Disconnect the cables from connector XCD and XUVW on the pulse transformer circuit board.

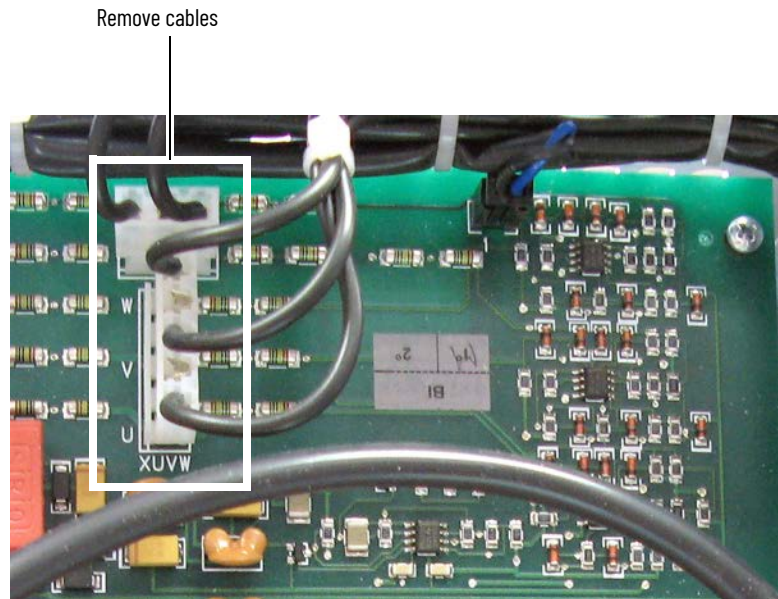

- Cut the cable ties that secure all cables and remove the transient noise filter board and cables from the drive.

Install the Transient Noise Filter Circuit Board

Install the transient noise filter board and power supply filter board in reverse order of removal.

Power Supply Filter Circuit Board Removal and Installation

Remove the Power Supply Filter Circuit Board

- Read the [General Safety Precautions on page 9](#).
- Remove power from the drive. See [Remove Power from the Drive on page 39](#).
- Remove the covers from the drive. See [Remove the Protective Covers from the Drive on page 41](#).

IMPORTANT Mark all connections and wires before removal to avoid incorrect wiring during reassembly.

- Remove all wires from the bottom of the terminal blocks on the power supply filter board.
- Remove the two screws and washers that secure the bottom of the power supply filter board to the drive.

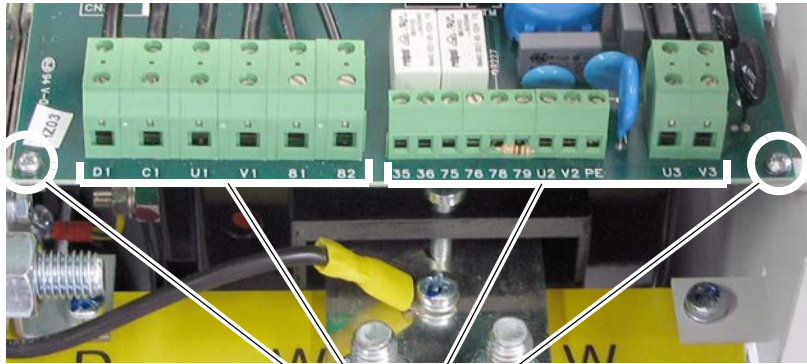

Remove wires, screws and washers

6. Move the control EMI shield. See [Move the Control EMI Shield on page 54](#).
7. Disconnect the wires from connectors X5, XTM, and XUV on the power supply filter board.

Remove connections

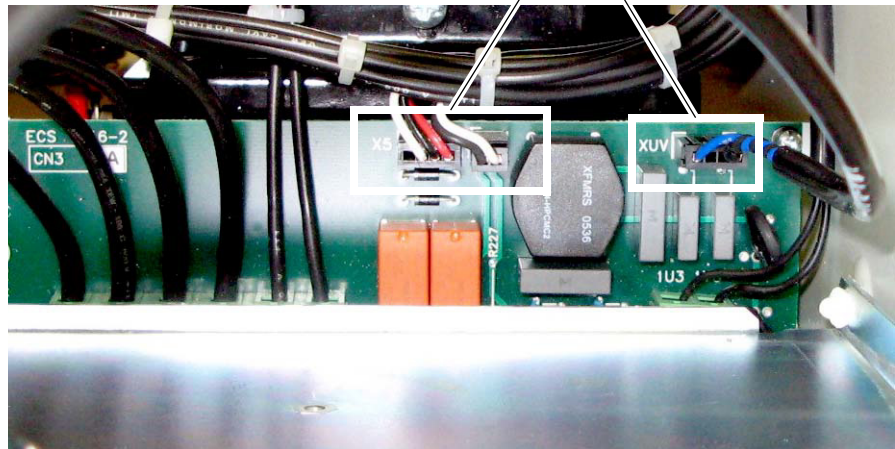

8. Remove all connections from the top of the terminal blocks on the power supply filter board.
9. Remove the two screws and washers that secure the top of the power supply filter board to the drive and remove the board from the drive.

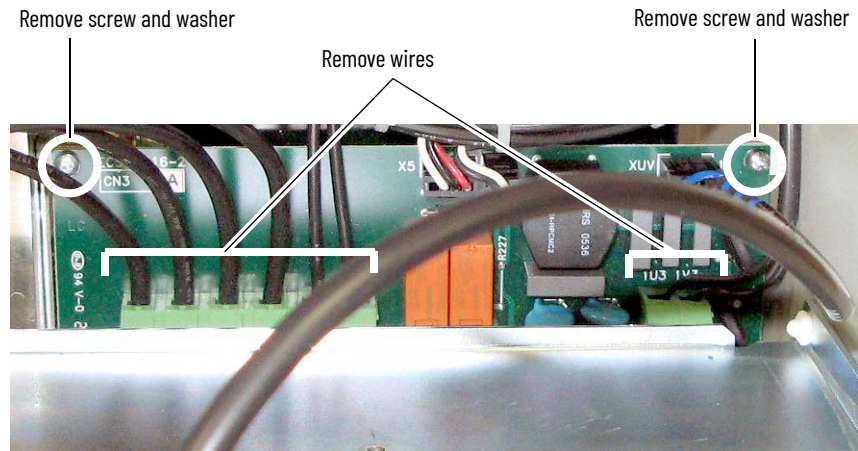

Install the Power Supply Filter Circuit Board

Install the power supply filter board in reverse order of removal.

Armature Leg Fuses Removal and Installation

Remove the Armature Leg Fuses

Note This procedure requires the use of a 17mm open ended wrench.

1. Read the [General Safety Precautions on page 9](#).
2. Remove power from the drive. See [Remove Power from the Drive on page 39](#).
3. Remove the covers from the drive. See [Remove the Protective Covers from the Drive on page 41](#).

IMPORTANT It is necessary to remove the transient noise filter circuit board in order to remove the fuses from the V phase input bus bars.

4. Remove the two screws and washers that secure the bottom of the transient noise filter board to the drive.

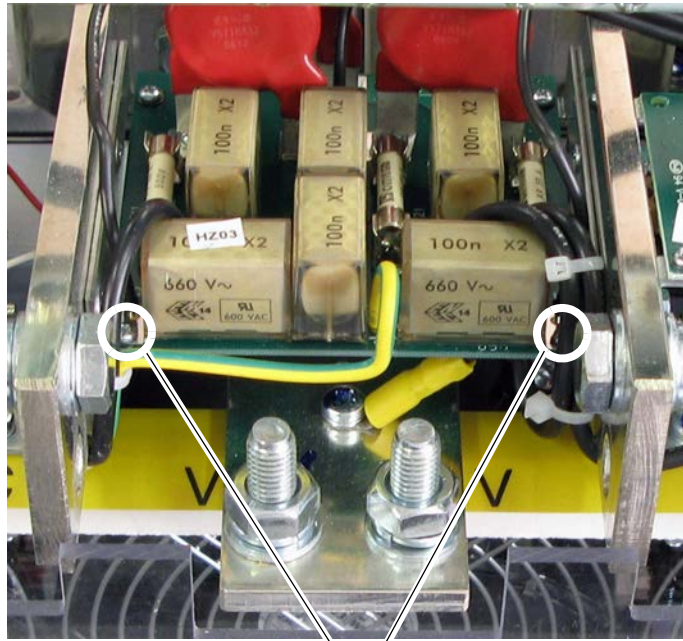

Remove screws and washers

5. Move the control EMI shield. See [Move the Control EMI Shield on page 54](#).
6. Remove the two screws and washers that secure the top of the transient noise filter board to the drive and carefully lift the board off the drive.

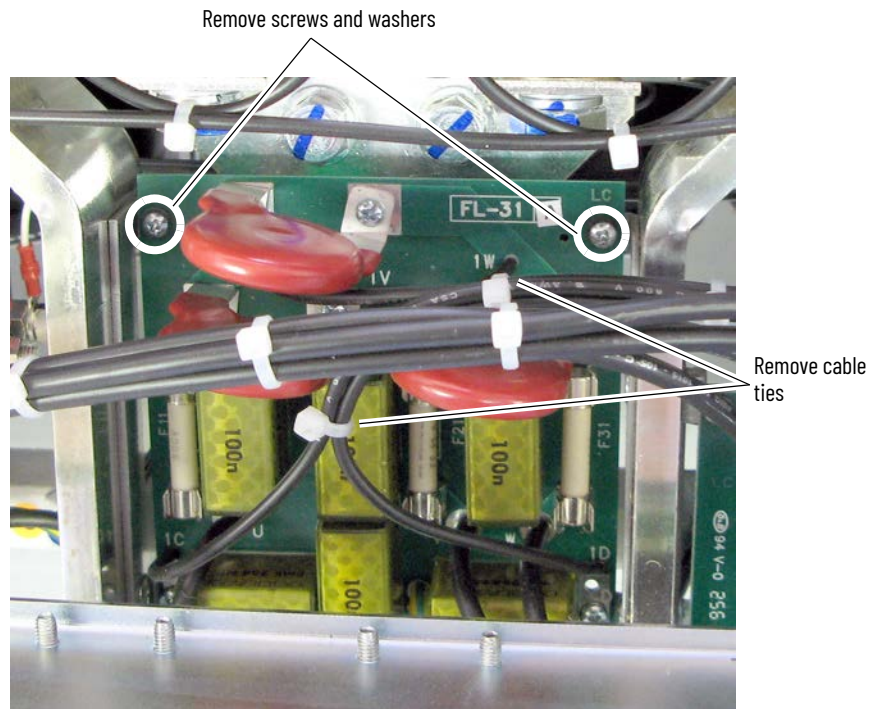

7. If present, remove the isolation sheet that is secured to the bus bars.

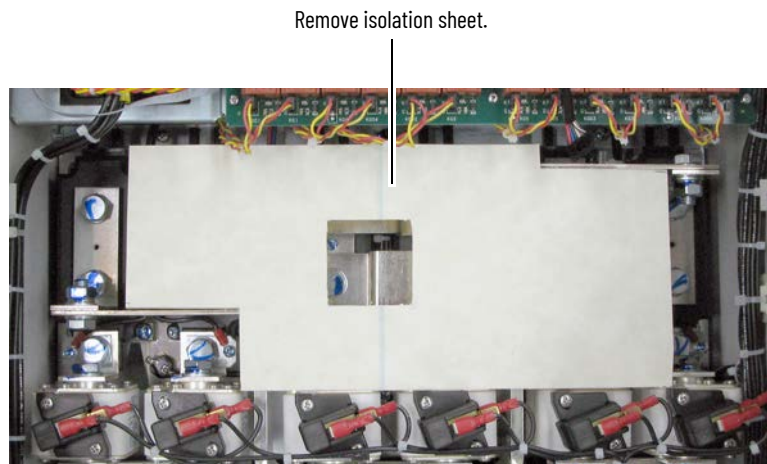

Note Regenerati e Dri e Shown

8. If necessary, disconnect the wire leads from the switches mounted on the top of the Armature circuit fuses (two each fuse).

IMPORTANT Note the numbered position of each wire on the fuse for proper installation of the new fuses.

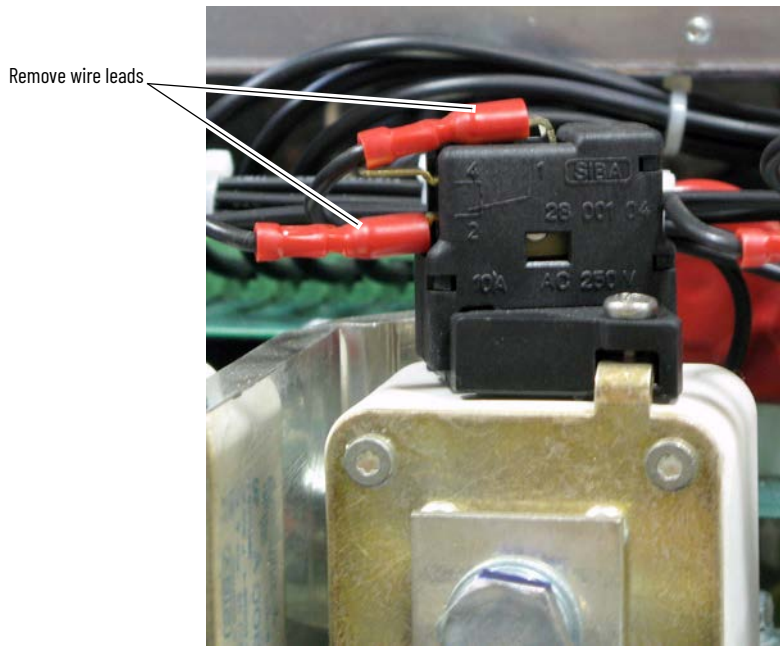

9. Remove the two screws that secure each switch to the fuse and remove the switch. Retain the switch for reuse.

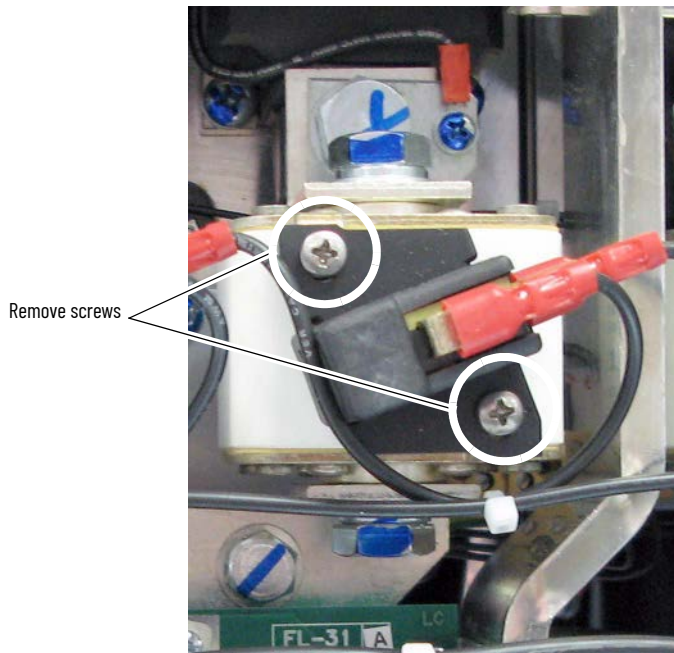

10. Remove the bolts and washers (top and bottom) that secure the fuse to the bus bars and remove the fuse.

IMPORTANT Note the order of the washers as you remove them in order to install in the proper order.

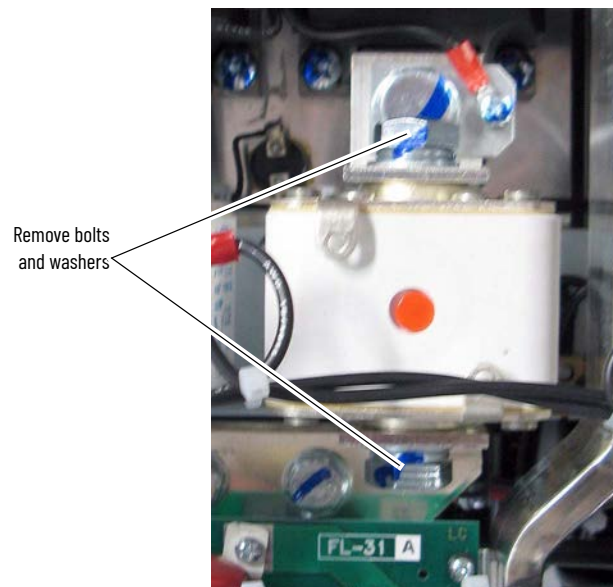

Install the Armature Leg Fuses

Install the armature leg fuses in reverse order of removal.

IMPORTANT Verify that the washers are installed in the proper order and that the switches are installed on the correct fuse.

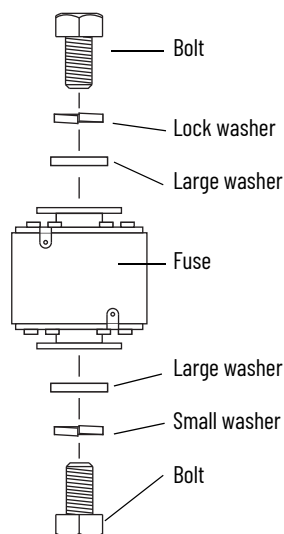

SCR Modules Removal and Installation

Remove the SCR Modules

IMPORTANT It is recommended that you replace the armature leg fuses for each pair of SCR modules that you replace in the drive. See [Remove the Armature Leg Fuses on page 82](#).

1. Read the [General Safety Precautions on page 9](#).
2. Remove power from the drive. See [Remove Power from the Drive on page 39](#).
3. Remove the covers from the drive. See [Remove the Protective Covers from the Drive on page 41](#).

4. Move the control EMI shield. See [Move the Control EMI Shield on page 54](#).
5. Remove the gate leads from the pulse transformer board.

Non Regenerative Drive

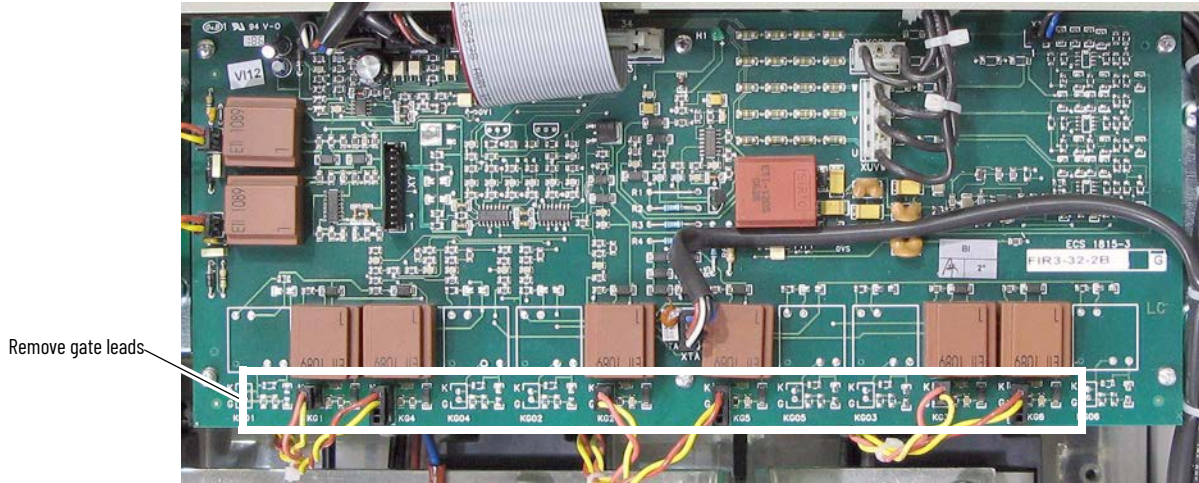

Regenerative Drive

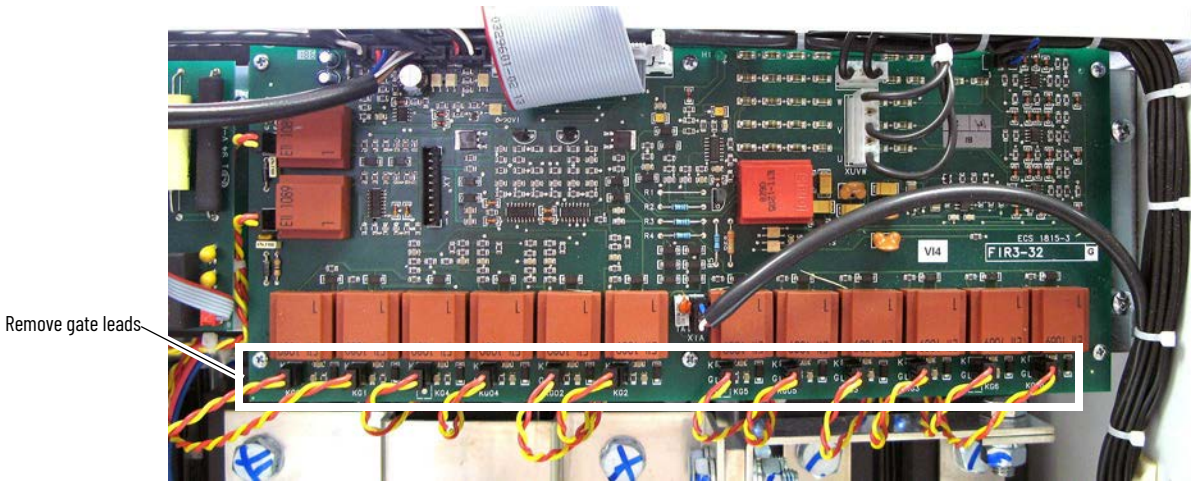

6. If present, remove the isolation sheet that is secured to the bus bars.

Remove isolation sheet.

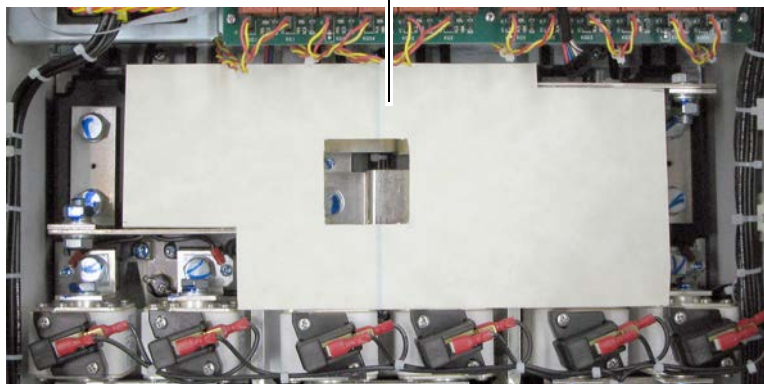

Note: Regenerative Drive Shown

7. Remove the bus bars in order to access the SCR modules in the drive:
 - For regenerative drives, see [Remove the Bus Bars from a Regenerative Drive on page 87](#).
 - For non-regenerative drives, see [Remove the Bus Bars from a Non-Regenerative Drive on page 89](#).

Remove the Bus Bars from a Regenerative Drive

1. Remove the six bolts and washers that secure the intermediate bus bars to the U and W phase AC input and DC output (terminals C and D) bus bars. Note the size and location of the bolts and the order in which the washers are placed on the bolts.

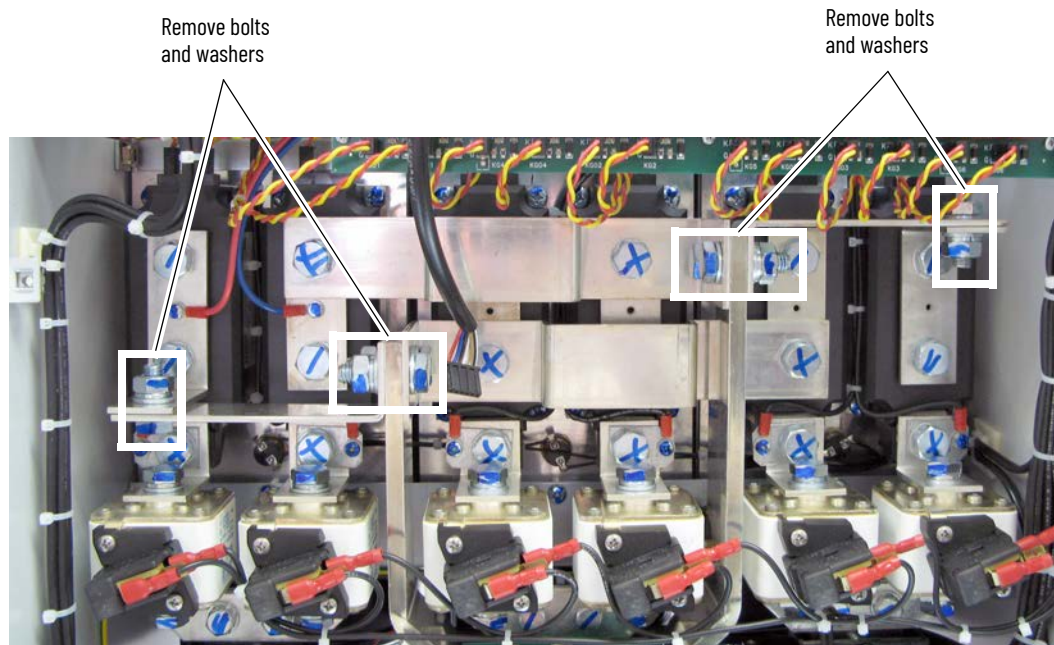

Bolt Size and Washer Order

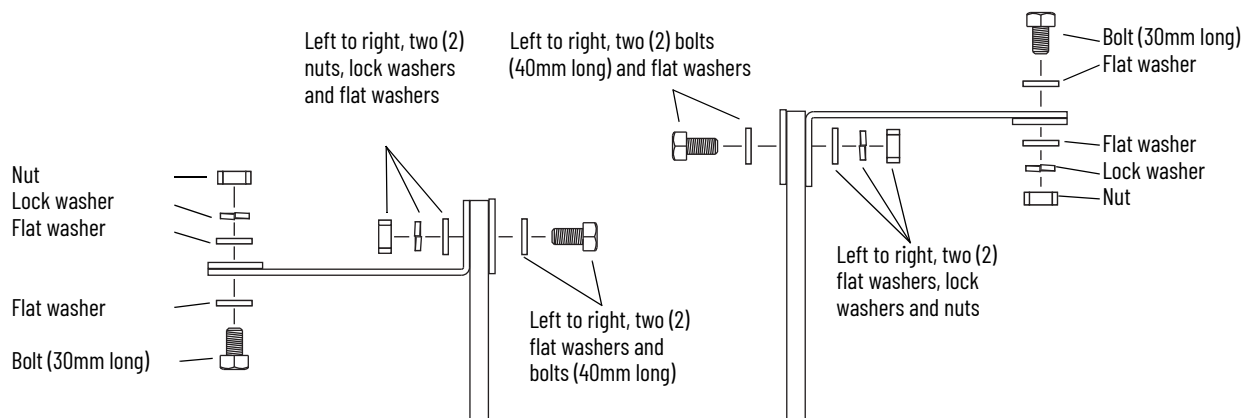

2. Remove the bolt (24 mm long) and washers that secure the L-shaped bus bars to the top of each of the six armature leg fuses. Note the order of the washers on the bolt.

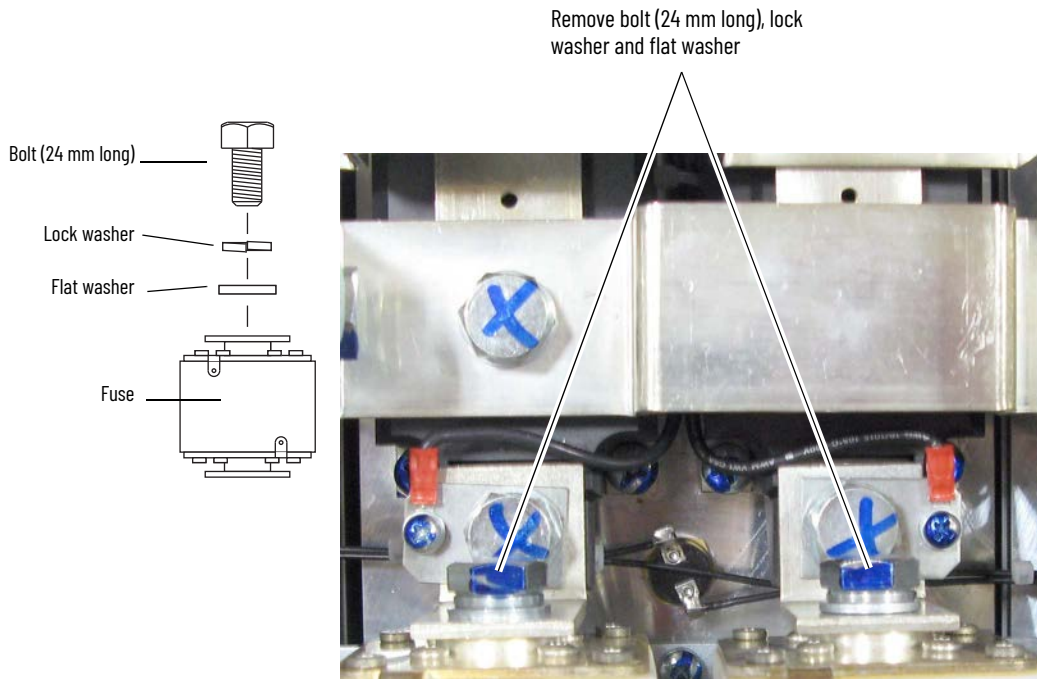

3. Remove the bolts (24mm long) and washers that secure the L-shaped bus bars to each of the SCR modules and remove the bus bars. Note: You do not need to remove the wires connected to the metal plate secured with the L-shaped bus bar.

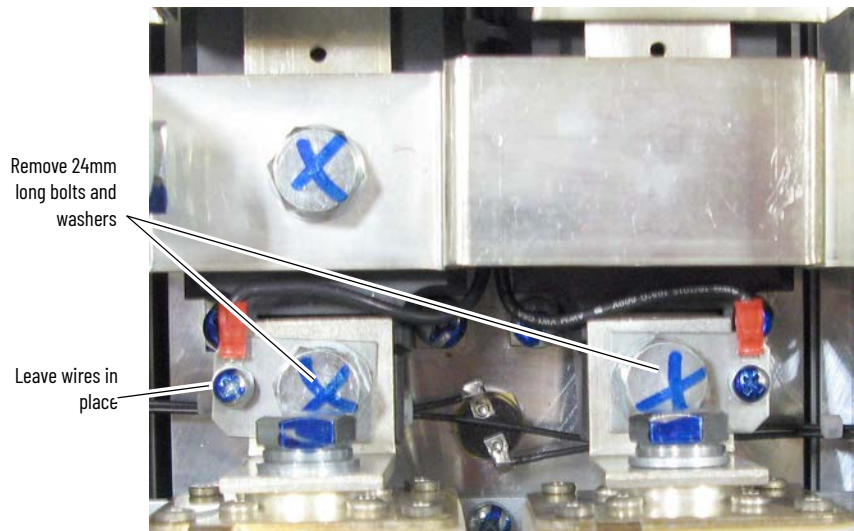

4. Remove the four bolts and washers that secure the horizontal bus bars to the SCR modules and remove the bus bars. Note the order of the washers on the bolts and the position of the bus bars.

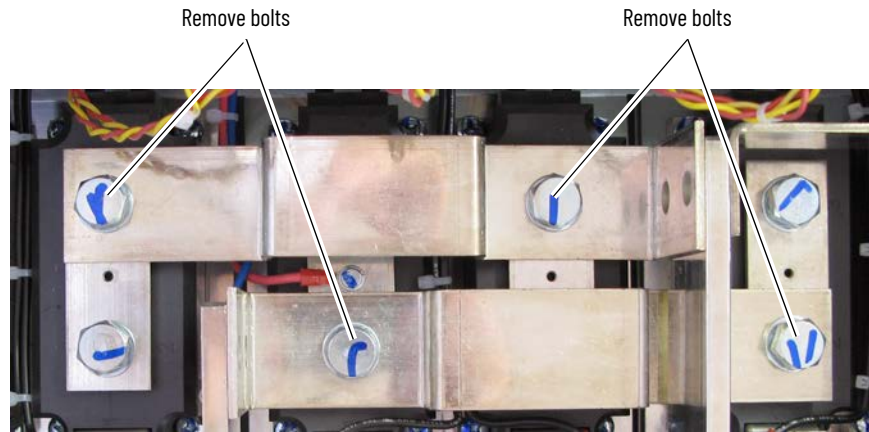

Continue with [Remove the SCR Modules on page 91](#).

Remove the Bus Bars from a Non-Regenerative Drive

1. Remove the nuts and washers that secure the wires (red and blue) from the AC line snubber board to the bus bars and remove the wires.

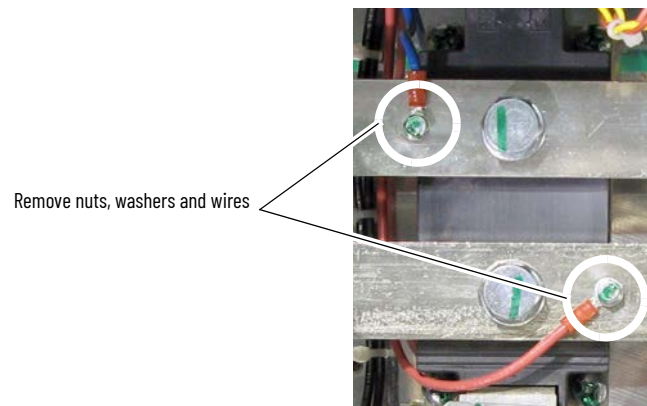

2. Remove the bolts and washers that secure the L-shaped bus bars to the top of each of the three armature leg fuses. Note the order of the washers on the bolt.

- Remove the bolts and washers that secure the metal plate and L-shaped bus bars to each of the SCR modules and remove the bus bars. Note: You do not need to remove the wires connected to the metal plate secured with the L-shaped bus bar.

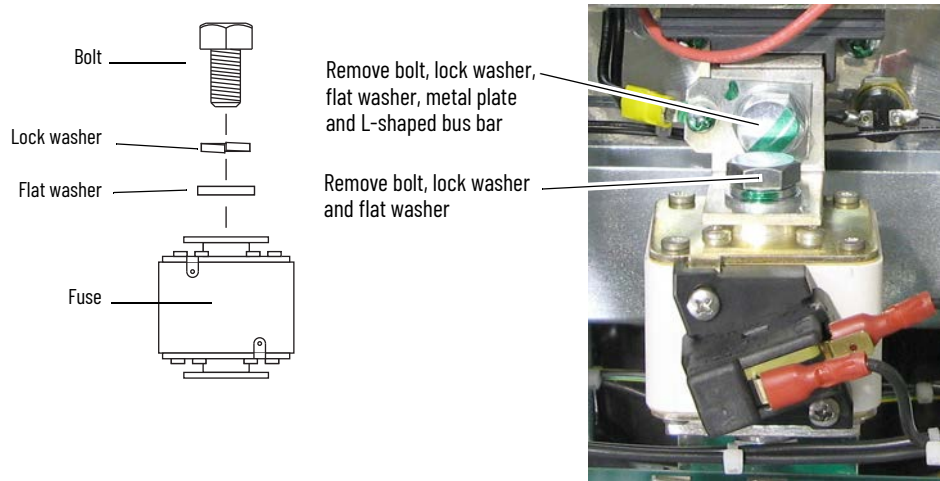

- Remove the bolts and washers that secure the horizontal bus bars to the C and D (vertical) power terminal bus bars. Note the size and location of the bolts and the order in which the washers are placed on the bolts.

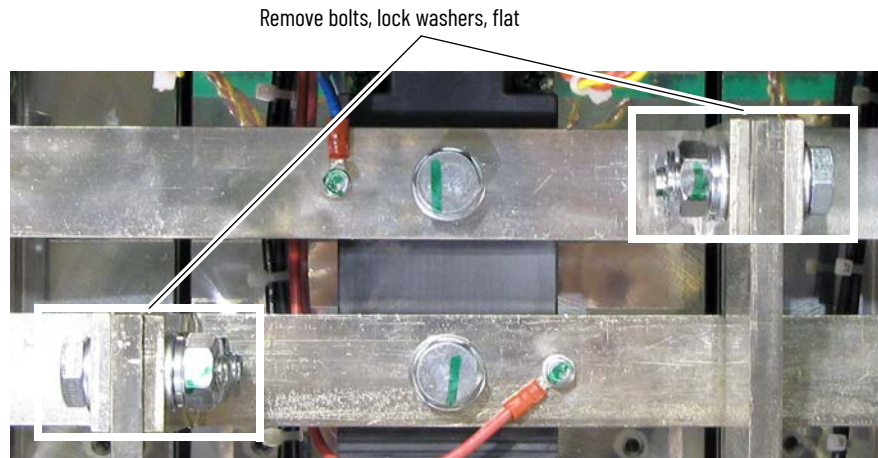

Bolt and Washer Order

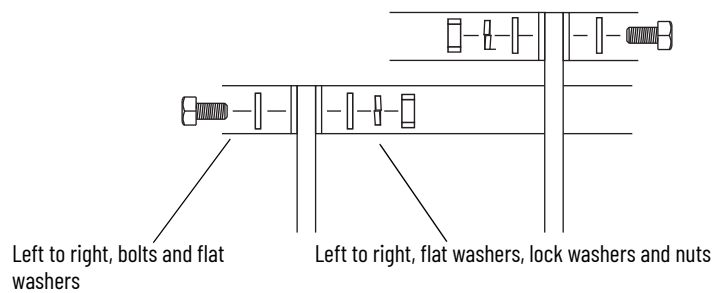

- Remove the bolts and washers that secure the horizontal bus bars to the SCR modules and remove the bus bars.

Remove bolts and washers and bus bars

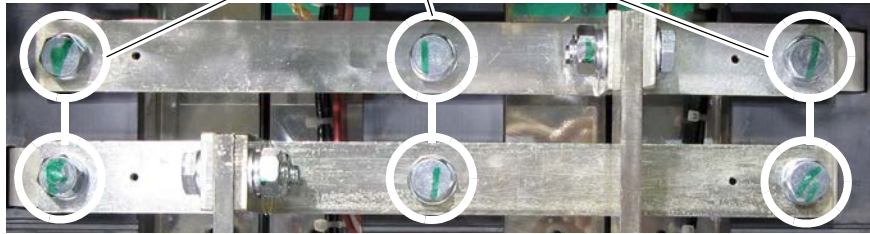

Continue with Remove the SCR Modules below.

Remove the SCR Modules

1. Remove the remaining bolts, washers, and metal plates (for regenerative drives only) from the tops of the SCR modules. Note the order of the washers on the bolts.

Note: Regenerative drive shown.

Remove bolts and metal plates

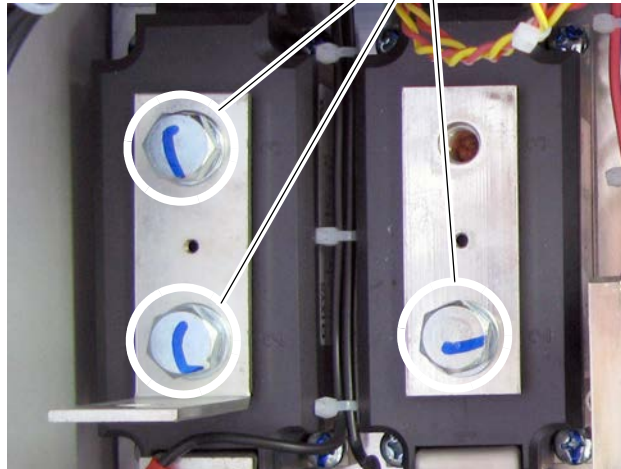
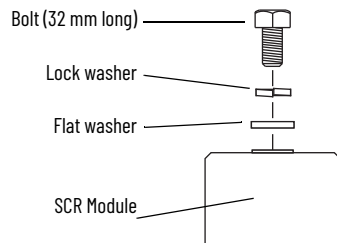

IMPORTANT Mark all connections and wires before removal to avoid incorrect wiring during reassembly.

2. Remove the gate leads that connect the SCR modules to the pulse transformer circuit board from the pulse transformer circuit board end.
3. Remove the four screws that secure each SCR module to the heatsink and remove the SCR modules. Note the order of the washers on the bolt.

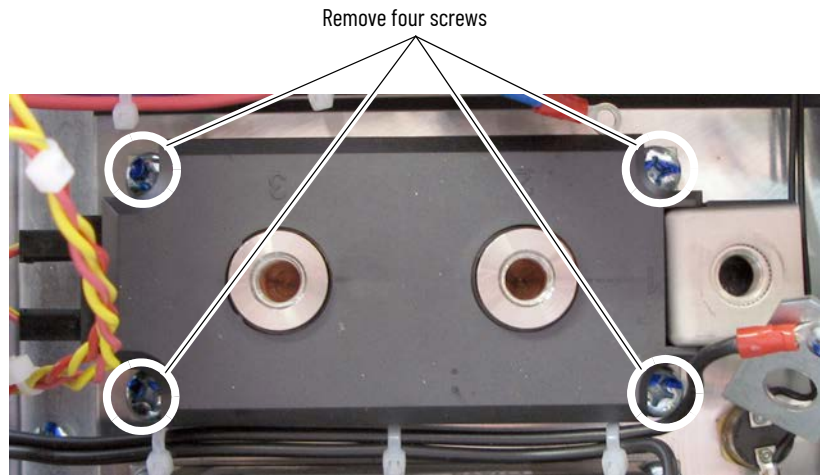

Install the SCR Modules

Install the SCR modules in reverse order of removal.

- Verify that each gate lead from the SCR modules is connected to the proper connector on the pulse transformer board.
- Apply thermal grease to the bottom of the SCR modules before securing them to the heatsink.



ATTENTION Thermal grease must be applied to the bottom of the SCR modules before securing them to the heatsink or damage to the drive may occur.

- Use the following table to determine the proper tightening torque for the SCR modules installed on the heatsink:

230V AC Input	
Part Number	Final Torque
SK-20P-S727F	4.5...5.5 N·m (40...48.7 lb·in)
SK-20P-S770F	6 N·m (53 lb·in)

460V AC Input	
Part Number	Final Torque
SK-20P-S737F	4.5...5.5 N·m (40...48.7 lb·in)
SK-20P-S771F	6 N·m (53 lb·in)

- Use the following table to determine the proper tightening torque for the bus bars connected to the SCR modules:

230V AC Input	
Part Number	Final Torque
SK-20P-S727F	11...13 N·m (97.4...115 lb·in)
SK-20P-S770F	11...13 N·m (97.4...115 lb·in)

460V AC Input	
Part Number	Final Torque
SK-20P-S737F	11...13 N·m (97.4...115 lb·in)
SK-20P-S771F	11...13 N·m (97.4...115 lb·in)

AC Current Transducers Removal and Installation

Remove the AC Current Transducers

1. Read the [General Safety Precautions on page 9](#).
2. Remove power from the drive. See [Remove Power from the Drive on page 39](#).
3. Remove the covers from the drive. See [Remove the Protective Covers from the Drive on page 41](#).
4. Remove the eight screws and washers that secure the Lexan shields to the bottom of the drive and remove the shields.

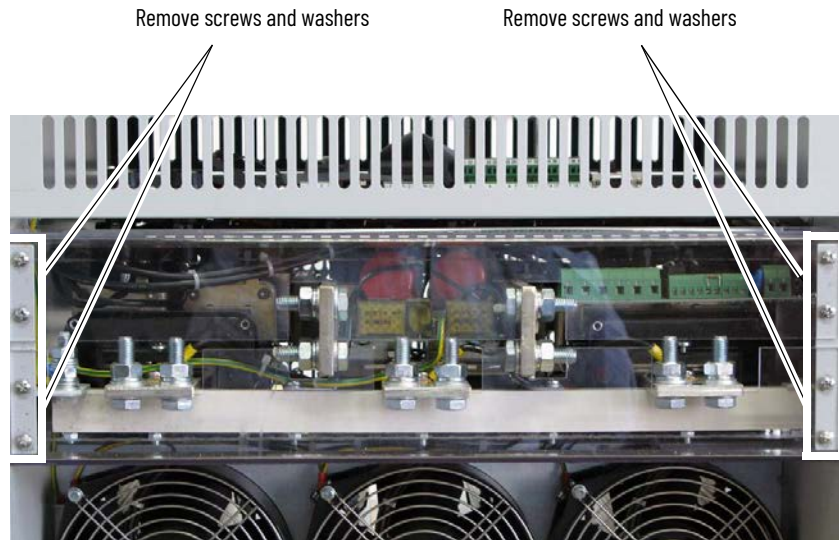

5. Remove the power wiring from the U and W phase AC input power terminals.
6. Remove the screws that secure the ground wires to the PE terminal (from the transient noise filter board) and U phase power terminal (from the pulse transformer board) and remove the wires.

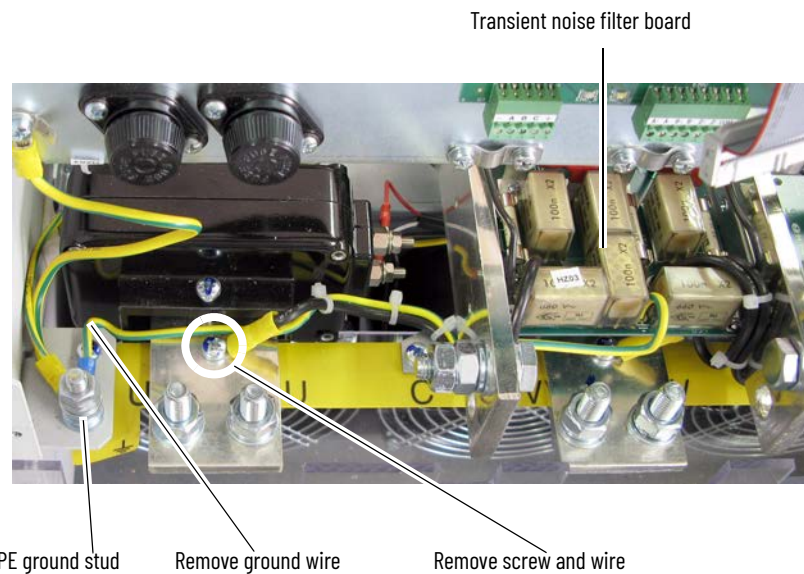

7. Remove the lower screw that secures the left side AC current transducer to the U phase terminal.

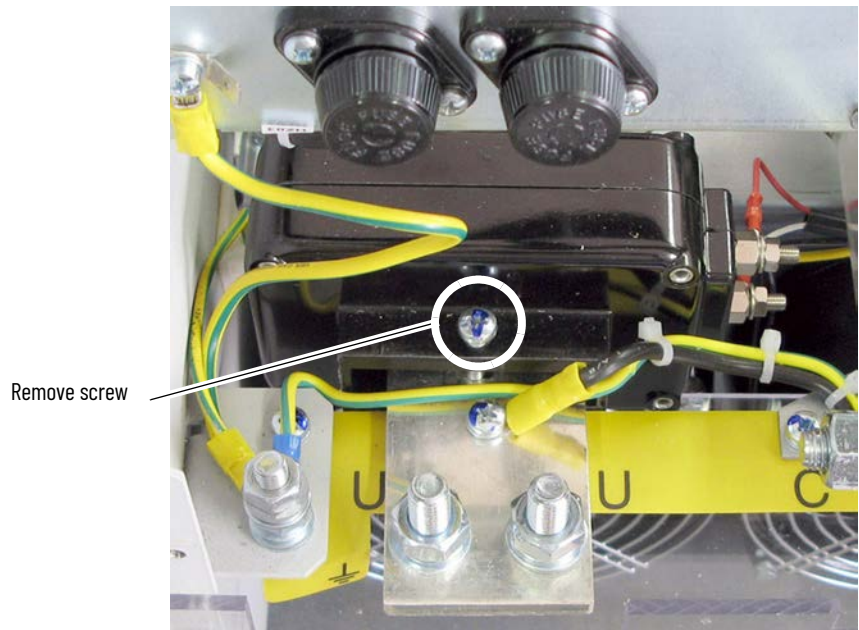

8. Remove the two screws that secure the bottom of the power supply filter circuit board to the drive.

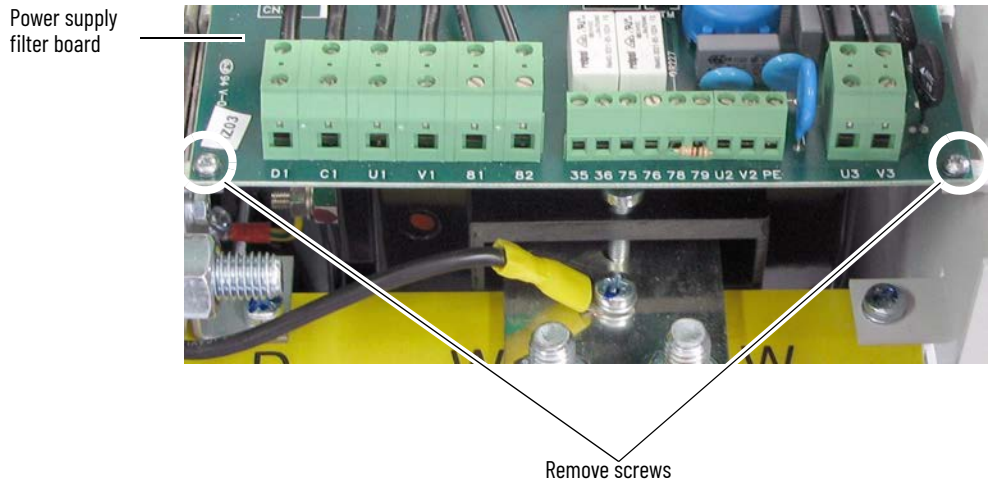

9. Move the control EMI shield. See [Move the Control EMI Shield on page 54](#).
10. Remove the two screws and washers that secure the top of the power supply filter board to the drive and carefully lift the board to gain access to the ground wire connected to the W phase power terminal (see next step).

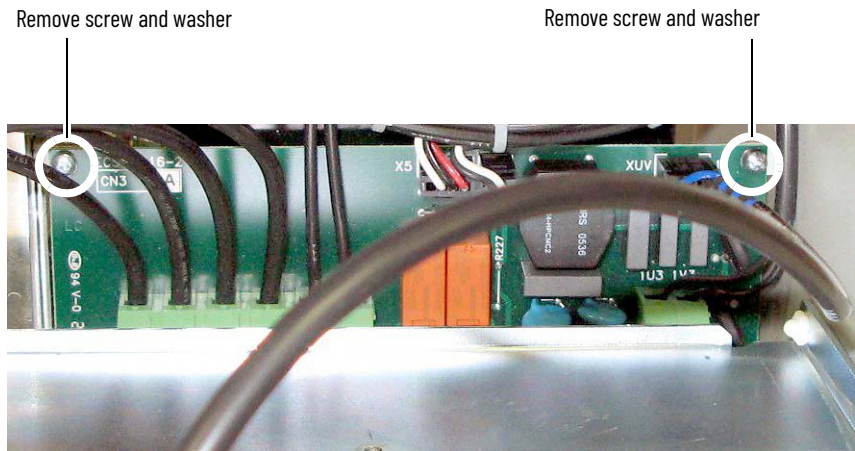

11. Temporarily lift the EMI shield and remove the screw that secures the ground wire (from the pulse transformer board) to W phase power terminal and remove the wire.

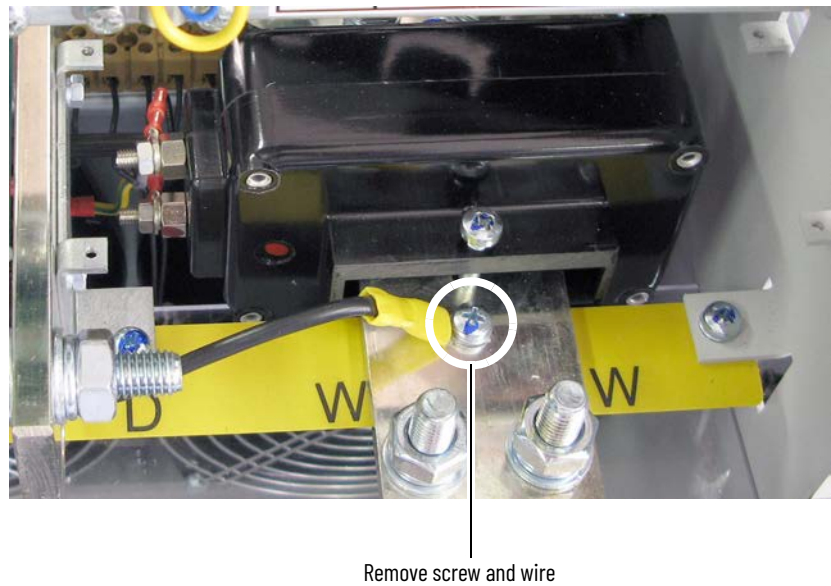

12. Remove the lower screw that secures the right side AC current transducer to the W phase power terminal.



Remove screw and wire

13. Move the EMI shield to the lowered position and remove the nuts and washers that secure the wires (red and white) to each of the AC current transducers and remove the wires.

IMPORTANT Note the color and location of each lead to ensure that each wire is properly connected during installation.

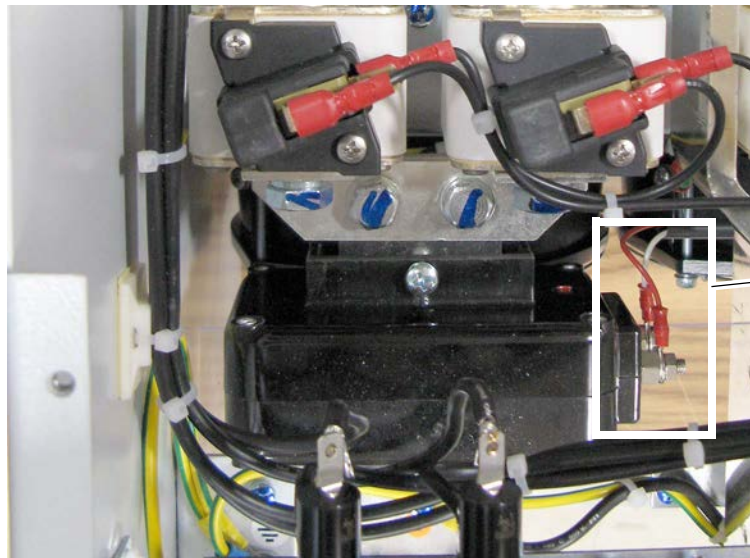

Remove nuts, washers and wires

Note: Left AC current transducer of regenerative drive shown.

14. Remove the upper screw that secures each of the AC current transducer to the U phase power terminal.

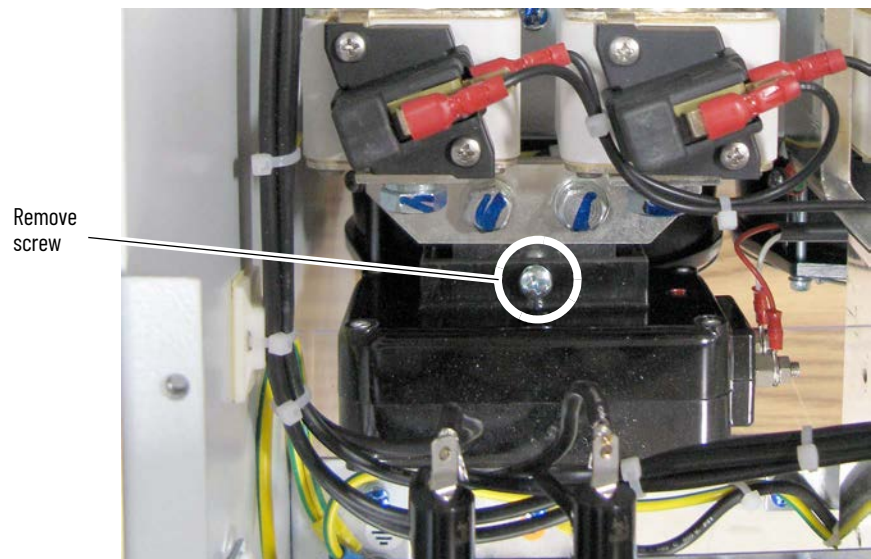

Note: Left AC current transducer of regenerative drive shown.

15. Remove the bolt(s) and washer(s) that secure the U and W phase power terminals to the L-shaped bus bar/fuse.
 - For regenerative drives only, remove the two bolts and washers that secure the U and W phase power terminals to the L-shaped bus bars connected to the fuses and while pulling the U and W phase power terminals down toward the bottom of the drive, slide the AC current transducers off of the terminal bus bars and out of the drive.

Regenerative drive

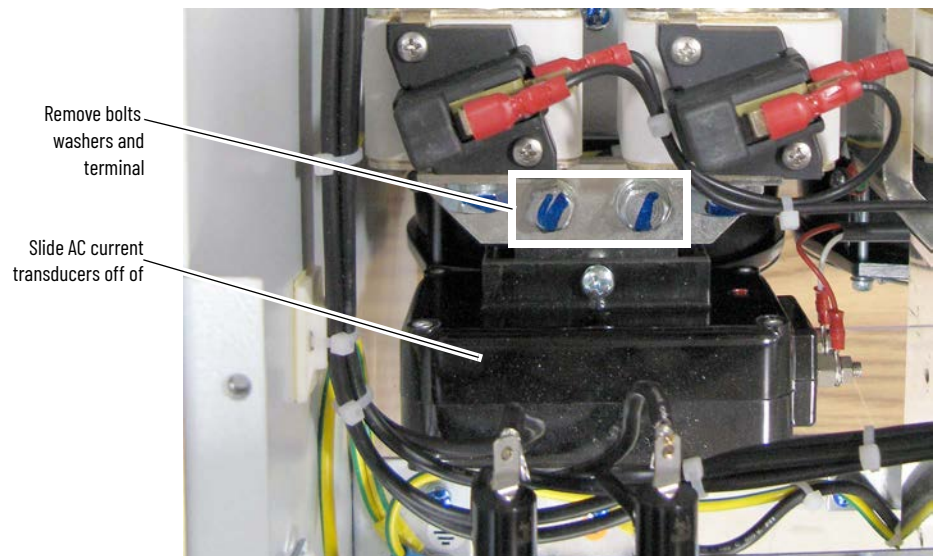

- For Non-Regenerative drives only, remove the bolt and washers that secure the U and W phase power terminals to the internal armature fuse and while pulling the U and W phase power terminals up and into the drive, slide the AC current transducers off of the terminal bus bars and out of the drive.

Non Regenerative drive

Remove bolts,
washers and terminal

Slide AC Current
Transducers off of bar

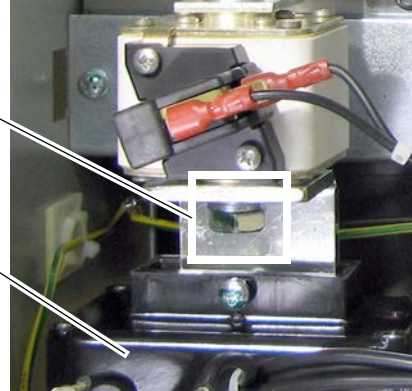

Install the AC Current Transducers

Install the AC current transducers in reverse order of removal.

IMPORTANT Note the color and location of the signal wires to ensure that each wire is properly connected during installation. The wires connected to the left CT are red and white and the wires connected to the right CT are blue and black.

Left AC Current Transducer

Right AC Current Transducer

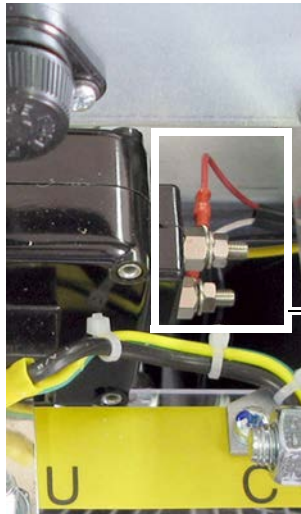

Right CT - blue and
black wires

Left CT - red and
white wires

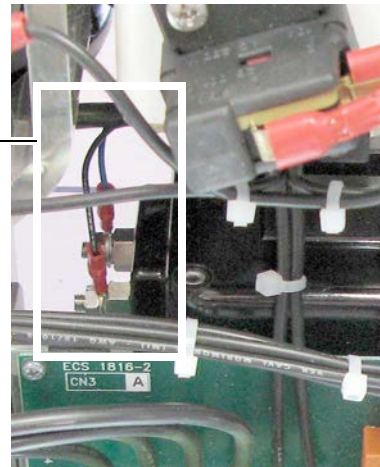

**Bimetal Thermostats
Removal and Installation**

Remove the Bimetal Thermostats

1. Read the [General Safety Precautions on page 9](#).
2. Remove power from the drive. See [Remove Power from the Drive on page 39](#).
3. Remove the covers from the drive. See [Remove the Protective Covers from the Drive on page 41](#).
4. Move the control EMI shield. See [Move the Control EMI Shield on page 54](#).

5. If present, remove the isolation sheet that is secured to the bus bars.

Remove isolation sheet.

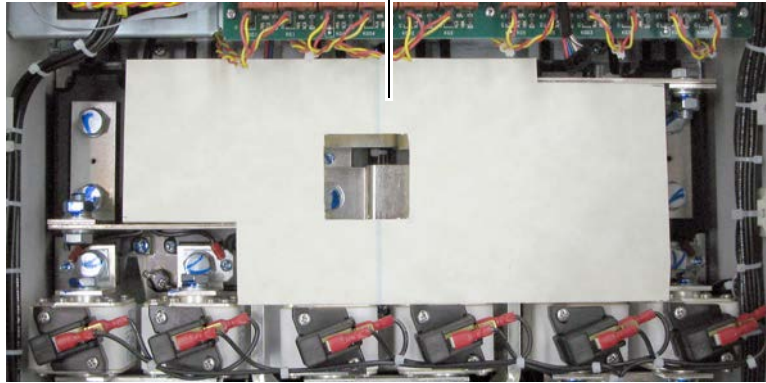

IMPORTANT You must remove the bus bars and, for regenerative drives, one SCR module from each pair, for non-regenerative drives, all SCR modules, in order to easily access and remove the bimetal thermostats.

6. Remove the bus bars in order to access the bimetal thermostats in the drive:
 - For regenerative drives, refer to [Remove the Bus Bars from a Regenerative Drive on page -99.](#)
 - For non-regenerative drives, refer to [Remove the Bus Bars from a Non-Regenerative Drive on page -102.](#)

Remove the Bus Bars from a Regenerative Drive

1. Remove the six bolts and corresponding washers that secure the intermediate bus bars to the U and W phase AC input and DC output (terminals C and D) bus bars. Note the size and location of the bolts and the order in which the washers are placed on the bolts.

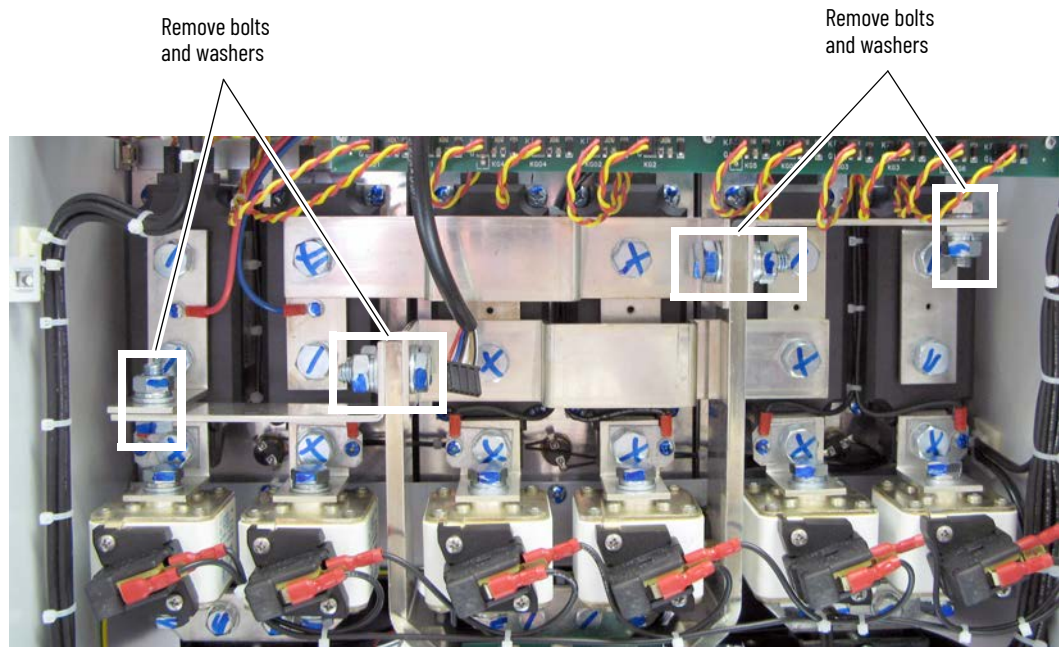

Bolt Size and Washer Order

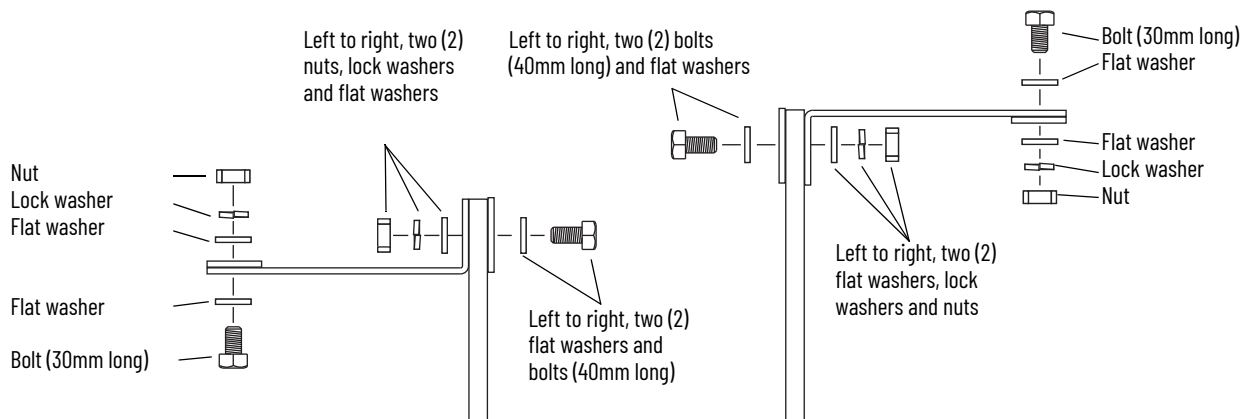

2. Remove the bolt (24 mm long) and washers that secure the L-shaped bus bars to the top of each of the six internal armature leg fuses. Note the order of the washers on the bolt.

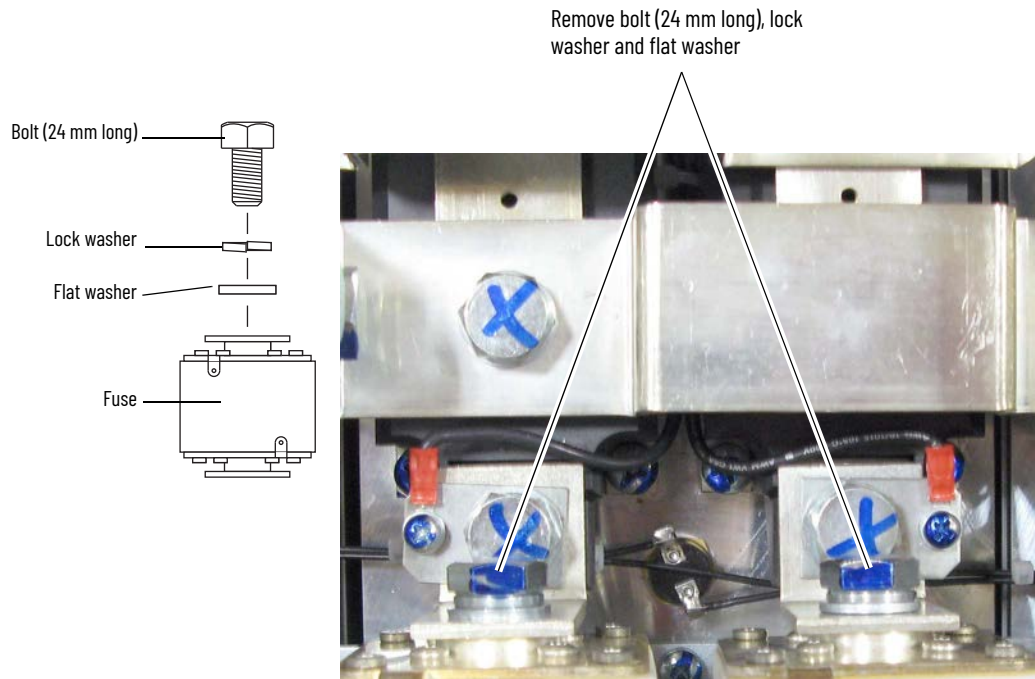

3. Remove the bolts (24mm long) and washers that secure the L-shaped bus bars to each of the SCR modules and remove the bus bars. Note: You do not need to remove the wires connected to the metal plate secured with the L-shaped bus bar.

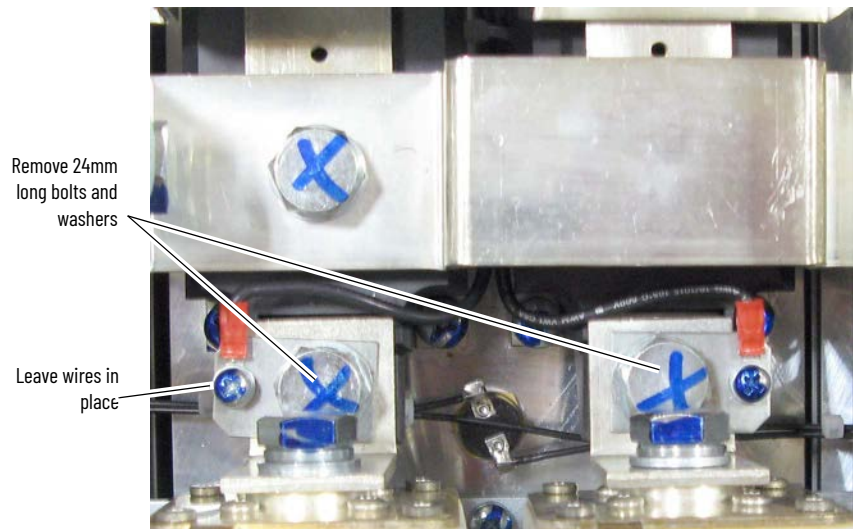

4. Remove the four bolts and washers that secure the horizontal bus bars to the SCR modules and remove the bus bars. Note the order of the washers on the bolts and the position of the bus bars.

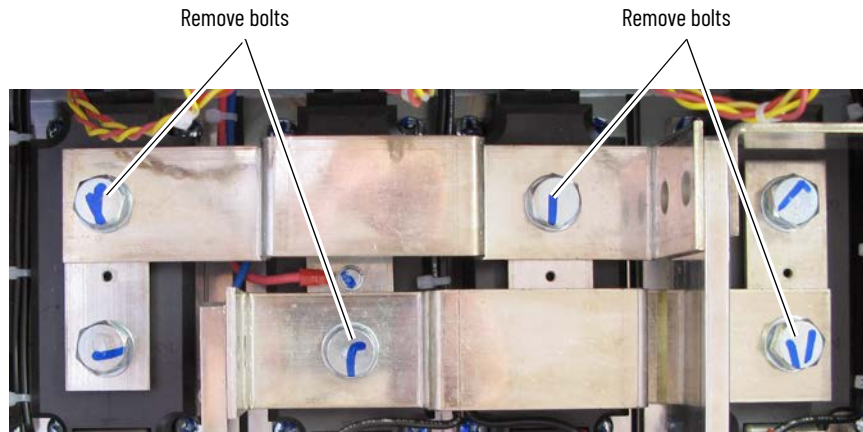

Continue with [Remove the SCR Modules and Bimetal Thermostats on page -104.](#)

Remove the Bus Bars from a Non-Regenerative Drive

1. Remove the nuts and washers that secure the wires (red and blue) from the AC line snubber board to the bus bars and remove the wires.

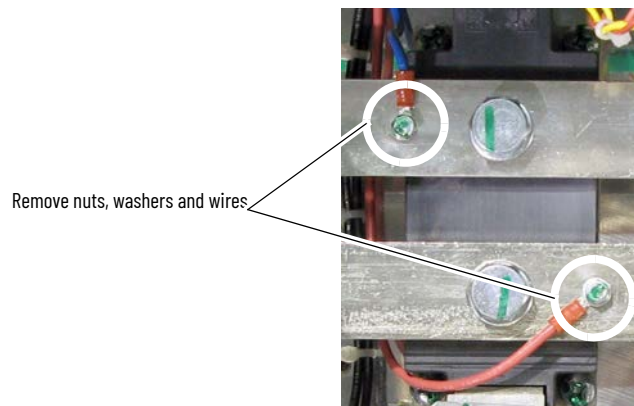

2. Remove the bolts and washers that secure the L-shaped bus bars to the top of each of the three internal armature leg fuses. Note the order of the washers on the bolt.
3. Remove the bolts and washers that secure the metal plate and L-shaped bus bars to each of the SCR modules and remove the bus bars. Note: You do not need to remove the wires connected to the metal plate secured with the L-shaped bus bar.

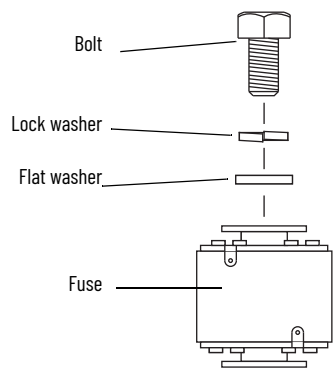

Remove bolt, lock washer, flat washer, metal plate and L-shaped bus bar

Remove bolt, lock washer and flat washer



4. Remove the bolts and washers that secure the horizontal bus bars to the C and D (vertical) power terminal bus bars. Note the size and location of the bolts and the order in which the washers are placed on the bolts.

Remove bolts, lock washers, flat washers

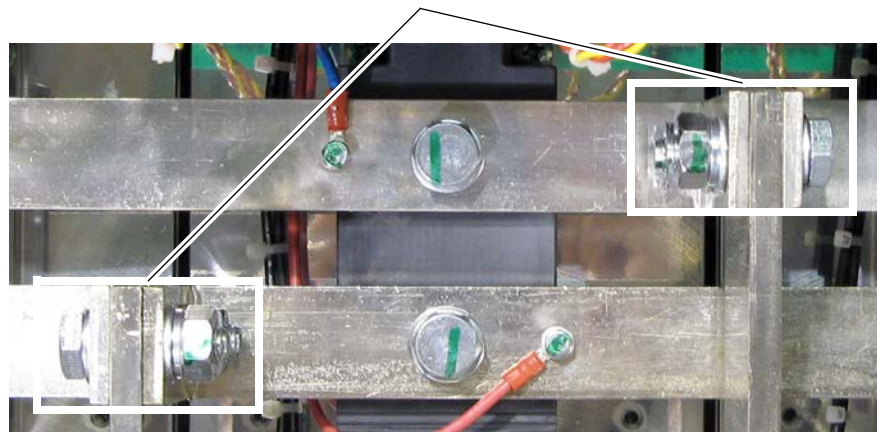

Bolt and Washer Order

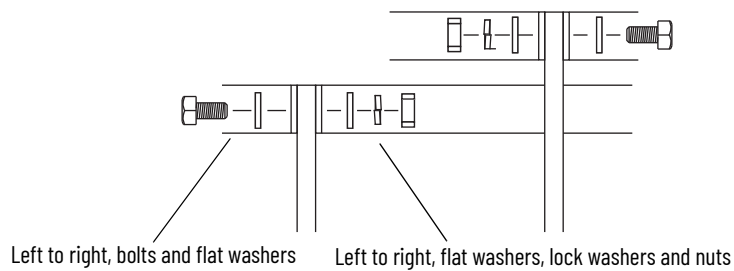

5. Remove the bolts and washers that secure the horizontal bus bars to the SCR modules and remove the bus bars.

Remove bolts and washers and bus bars

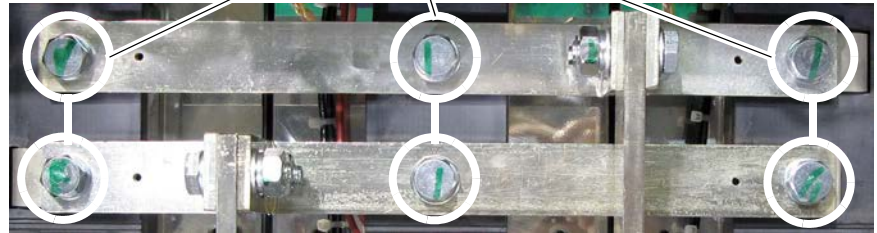

Continue with Remove the SCR Modules and Bimetal Thermostats below.

Remove the SCR Modules and Bimetal Thermostats

1. Remove the remaining bolts, washers and metal plates (for regenerative drives only) from the tops of the SCR modules. Note the order of the washers on the bolts.

Note: Regenerative drive shown.

Remove bolts and metal plates

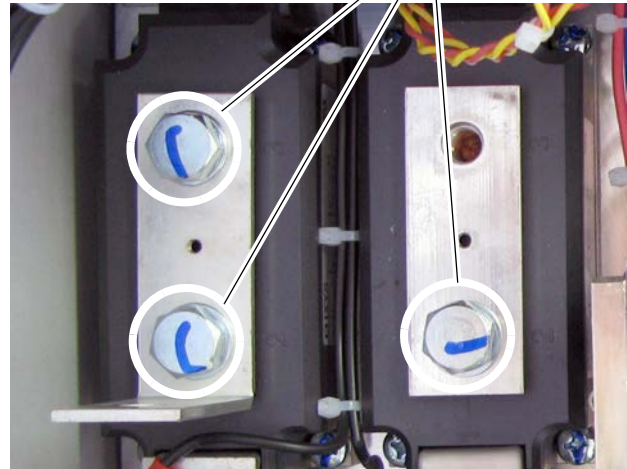
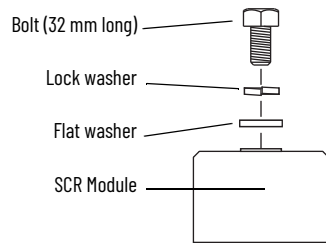

IMPORTANT Mark all connections and wires before removal to avoid incorrect wiring during reassembly.

2. Remove the gate leads that connect the SCR modules to the pulse transformer circuit board from the pulse transformer circuit board end.
3. Remove the four screws that secure each SCR module to the heatsink and remove the SCR modules. Note the order of the washers on the bolt.

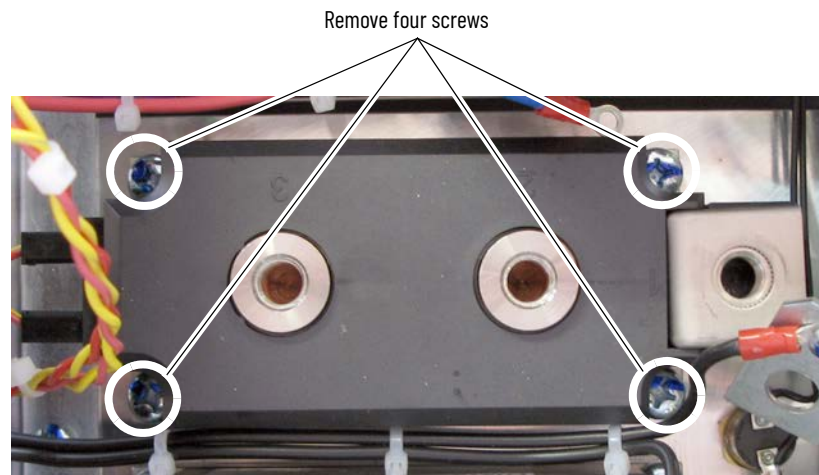

4. Remove the wires connected to the bimetal thermostats from connector X4 on the pulse transformer circuit board.
5. Remove the solder from the connections on the two leads of the bimetal thermostats.
6. Remove the bimetal thermostats from the heatsinks by unscrewing them at the base.

Remove solder and
bimetal thermostats

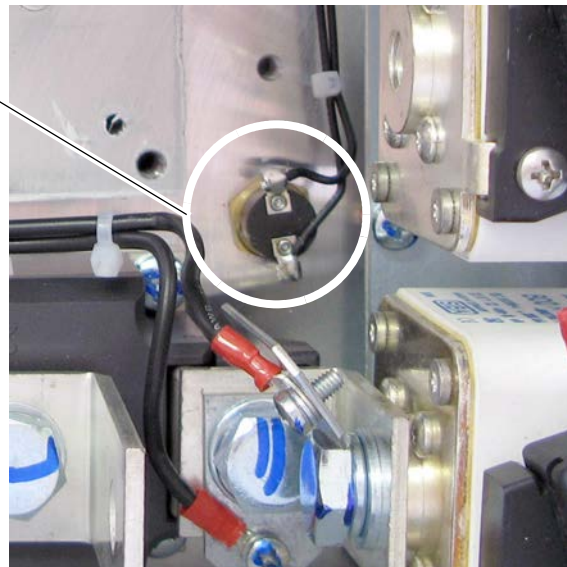

Install the Bimetal Thermostats

Install the bimetal thermostats in reverse order of removal.

- Apply thermal grease to the bottom of the bimetal thermostats before securing them to the heatsink.



ATTENTION Thermal grease must be applied to the bottom of the bimetal thermostats before securing them to the heatsink or damage to the drive may occur.

- Use the following table to determine the proper tightening torque for the screws that secure the SCR modules to the heatsink:

230V AC Input				
Drive Current Rating Code	DC Amps	AC Line Amps	HP	Final Torque
521	521	426	150	6 N·m (53 lb·in)

460V AC Input				
Drive Current Rating Code	DC Amps	AC Line Amps	HP	Final Torque
495	495	404.4	300	4.5...5.5 N·m (40...48.7 lb·in)
667	667	544.9	400	6 N·m (53 lb·in)

- Use the following table to determine the proper tightening torque for the bolts that secure the bus bars to the SCR modules:

230V AC Input				
Drive Current Rating Code	DC Amps	AC Line Amps	HP	Final Torque
521	521	426	150	11...13 N·m (97.4...115 lb·in)

460V AC Input				
Drive Current Rating Code	DC Amps	AC Line Amps	HP	Final Torque
495	495	404.4	300	11...13 N·m (97.4...115 lb·in)
667	667	544.9	400	

Cooling Fans Removal and Installation

Remove the Cooling Fans

1. Read the [General Safety Precautions on page 9](#).
2. Remove power from the drive. See [Remove Power from the Drive on page 39](#).
3. Remove the covers from the drive. See [Remove the Protective Covers from the Drive on page 41](#).
4. Move the control EMI shield. See [Move the Control EMI Shield on page 54](#).
5. Locate the cooling fan terminal block and loosen the screws that secure the fan power supply wires to the terminal block. The cooling fan terminal block is located below the internal armature leg fuses and between the phase V and W AC input bus bars.

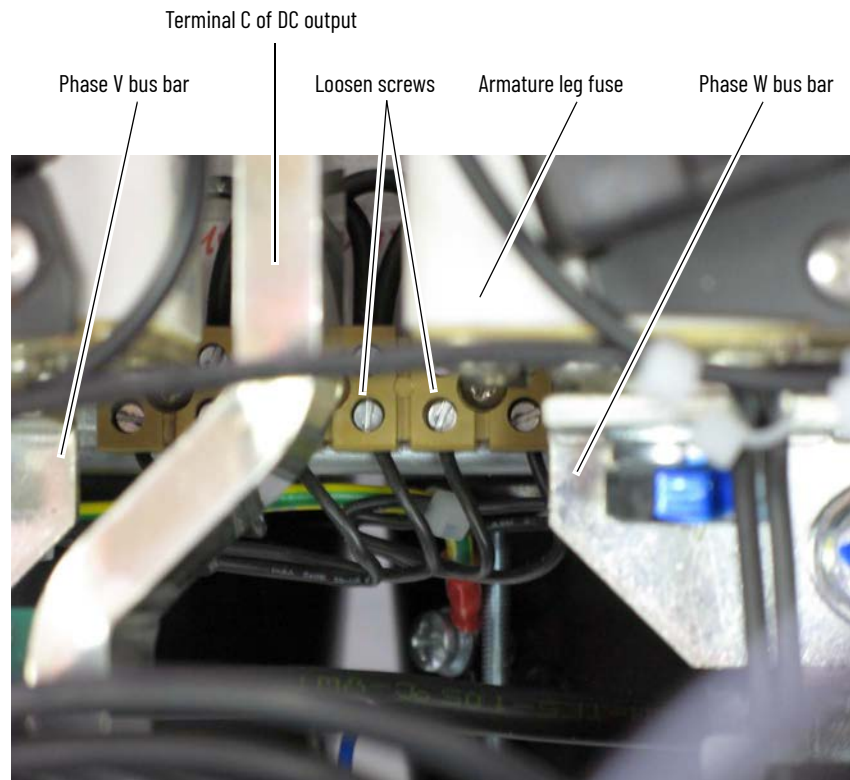

6. At the bottom of the drive, remove the two screws that secure the fan to the drive frame and pull the fan away from the drive.

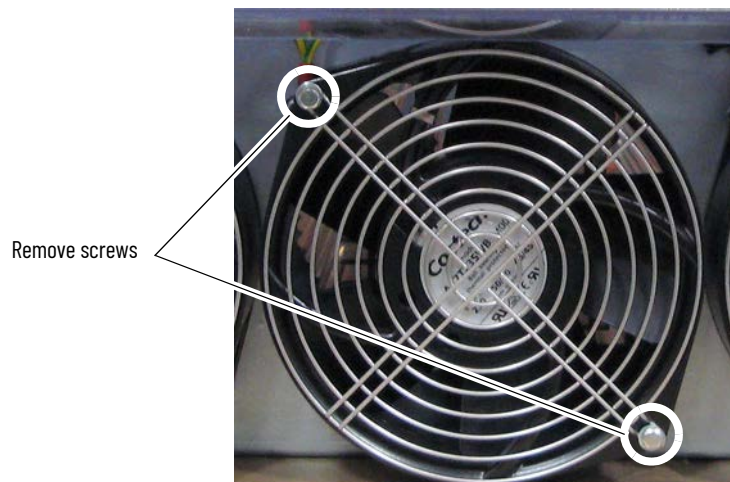

7. Remove the screw that secures the ground wire to the fan chassis and remove the ground wire.

Remove screw and wire



8. Remove the loosened fan power supply wires from the terminal block and remove the fan.

Remove wires from terminal block



Install the Cooling Fans

Install the cooling fans in reverse order of removal.

Start-Up After Repair

Before applying power to a repaired drive, perform the following tests:

- [Check the Armature SCR Modules on page 27](#)
- [Check the Field SCR/Dual Diode Module on page 32](#)
- Complete the [Test With the Motor, Without a Mechanical Load on page 109](#).

Test With the Motor Without a Mechanical Load

This test allows you to measure several operating parameters and diagnose problems without connecting the motor to its mechanical load.

This procedure requires a HIM to configure and autotune the drive. If you prefer, you can use the DriveExplorer™ or DriveExecutive™ software.





ATTENTION Power must be applied to the drive to perform the following start-up procedure. Some of the voltages present are at incoming line potential. To avoid electric shock hazard or damage to equipment, only qualified service personnel should perform the following procedure. Thoroughly read and understand the procedure before beginning. If an event does not occur while performing this procedure, **Do Not Proceed Remove Power** including user supplied control voltages. User supplied voltages may exist even when main AC power is not applied to then drive. Correct the malfunction before continuing.

1. Verify that the input power wiring and grounding is connected.
2. Verify that the motor cables are connected.
3. Verify that the motor load is disconnected.
4. Verify that the control board DIP switches are set correctly. See [Install the Control Circuit Board on page 54](#) for more information.
5. Apply power to the control circuits (terminals U2 and V2) of the drive.
6. Verify that the following parameter values are set correctly:
 - 45 [Max Ref Speed] is set to the motor nameplate base speed.
 - 162 [Max Feedback Spd] is set to the motor nameplate base speed.
 - 175 [Rated Motor Volt] is set to the motor rated nameplate armature voltage.
 - 179 [Nom Mtr Arm Amps] is set to the rated motor nameplate armature current.
 - 280 [Nom Mtr Fld Amps] is set to the rated motor nameplate field current.
 - 374 [Drv Fld Brdg Amps] is set to the rated current of the field bridge regulator
7. Energize the drive.
8. Measure the field current and verify that the value is reflected in parameter 234 [Fld Current Pct].

9. Run the following applicable Autotune procedures detailed in Chapter 2 of the TPDflex DC Converters User Manual, publication 1S7TFLEXUM0.
 - Tune the Current Regulator
 - Verify Motor Rotation Direction and Run Feedback Polarity Checks. If parameter 414 [Fdbk Device Type] is set to 3 "Armature", set parameter 107 [Speed Zero Level] to a minimum value of 10% of base motor speed.
 - Configure the Speed Feedback Parameters
 - Tune the Speed Regulator
 10. Make configuration changes that allow the HIM to issue start and speed commands.
 11. Start the drive, by pressing  (the start button).

If the drive will not start, verify that you have correctly installed any replacement components.

If any faults are displayed on the HIM, refer to Chapter 4 - Troubleshooting in the TPDflex DC Converters User Manual, publication 1S7TFLEXUM0.
 12. Increase the speed command from zero to base speed, by pressing  (the up button).
 13. Measure the output voltage and verify that it is reflected in parameter 233 [Output Voltage].
 14. Measure the armature current and verify that the value is reflected in parameter 199 [Arm Current Pct].
 15. Stop the drive, by pressing  (the stop button).
 16. If these measurements are correct, re-configure the drive to suit the application. Refer to Chapters 1 and 2 of the TPDflex DC Converters User Manual, publication 1S7TFLEXUM0 or assistance.
- If any of these measurements are incorrect, repeat steps 8...15. If the measurements are still incorrect, repeat the appropriate procedures in Chapter 2 - Component Test Procedures beginning on [page 13](#).

Schematics

List of Schematic Diagrams

Topic	Page
Figure 13 - Circuit Board Interconnection Diagram	112
Figure 14 - Non-regenerative Drive Power Module Diagram	113
Figure 15 - Regenerative Drive Power Module Diagram	114
Figure 16 - AC Line Measurement Points Diagram	115
Figure 17 - Power Feedback Connections Diagram	115
Figure 18 - Field Board and SCR/Dual Diode Module Connections Diagram	116
Figure 19 - Field Control Circuit Diagram	117
Figure 20 - Control Circuit Input Power Diagram	117
Figure 21 - Encoder Control Circuit Diagram	118
Figure 22 - DC Tachometer Control Circuit Diagram	118
Figure 23 - Motor Thermal Protection Control Circuit Diagram	119
Figure 24 - Drive Heatsink Monitoring Control Circuit Diagram	119
Figure 25 - Contactor Control Relays Control Circuit Diagram	120
Figure 26 - AC Line Snubber Circuit	120

Figure 16 - Circuit Board Interconnection Diagram

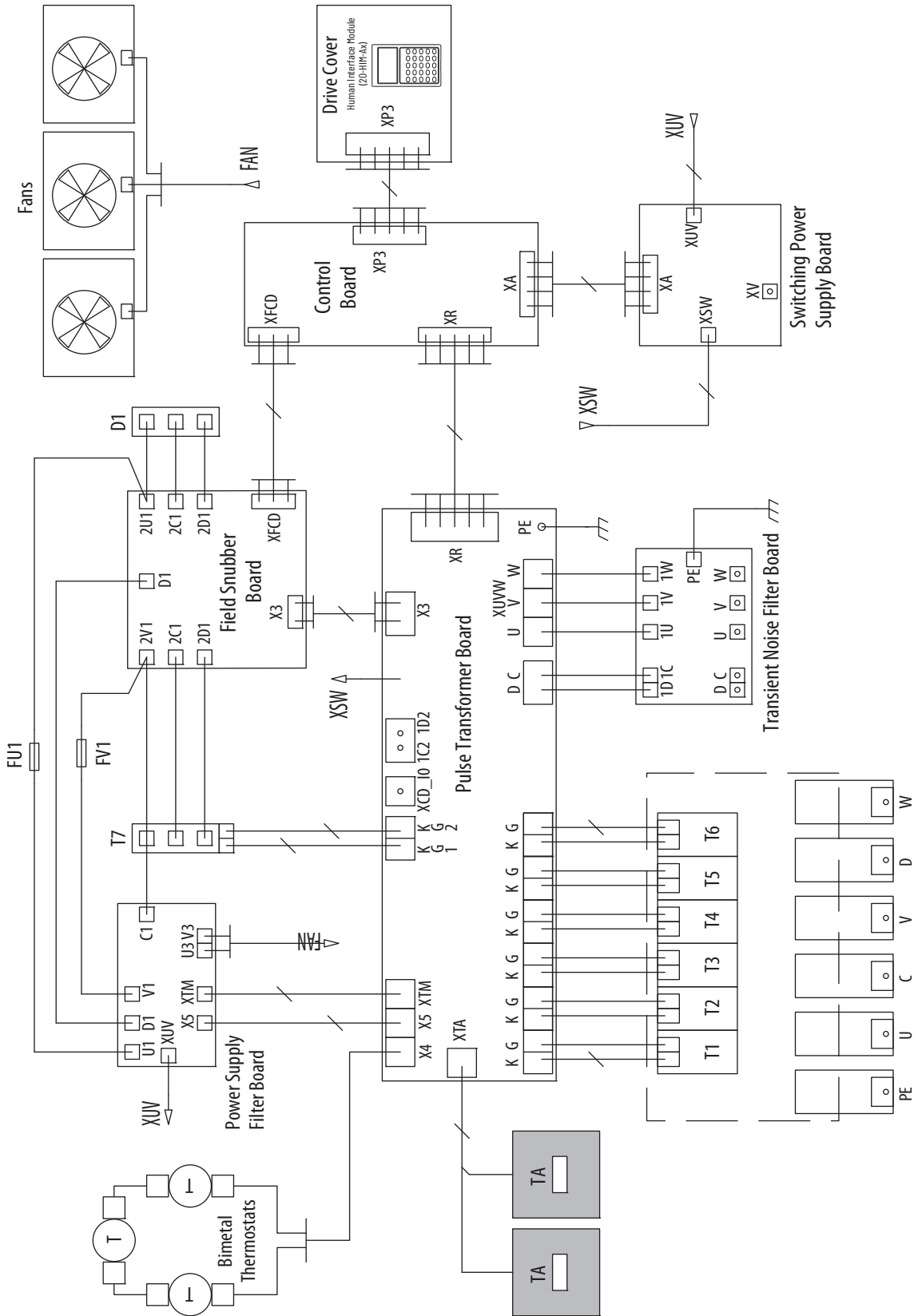

Figure 17 - Non-regenerative Drive Power Module Diagram

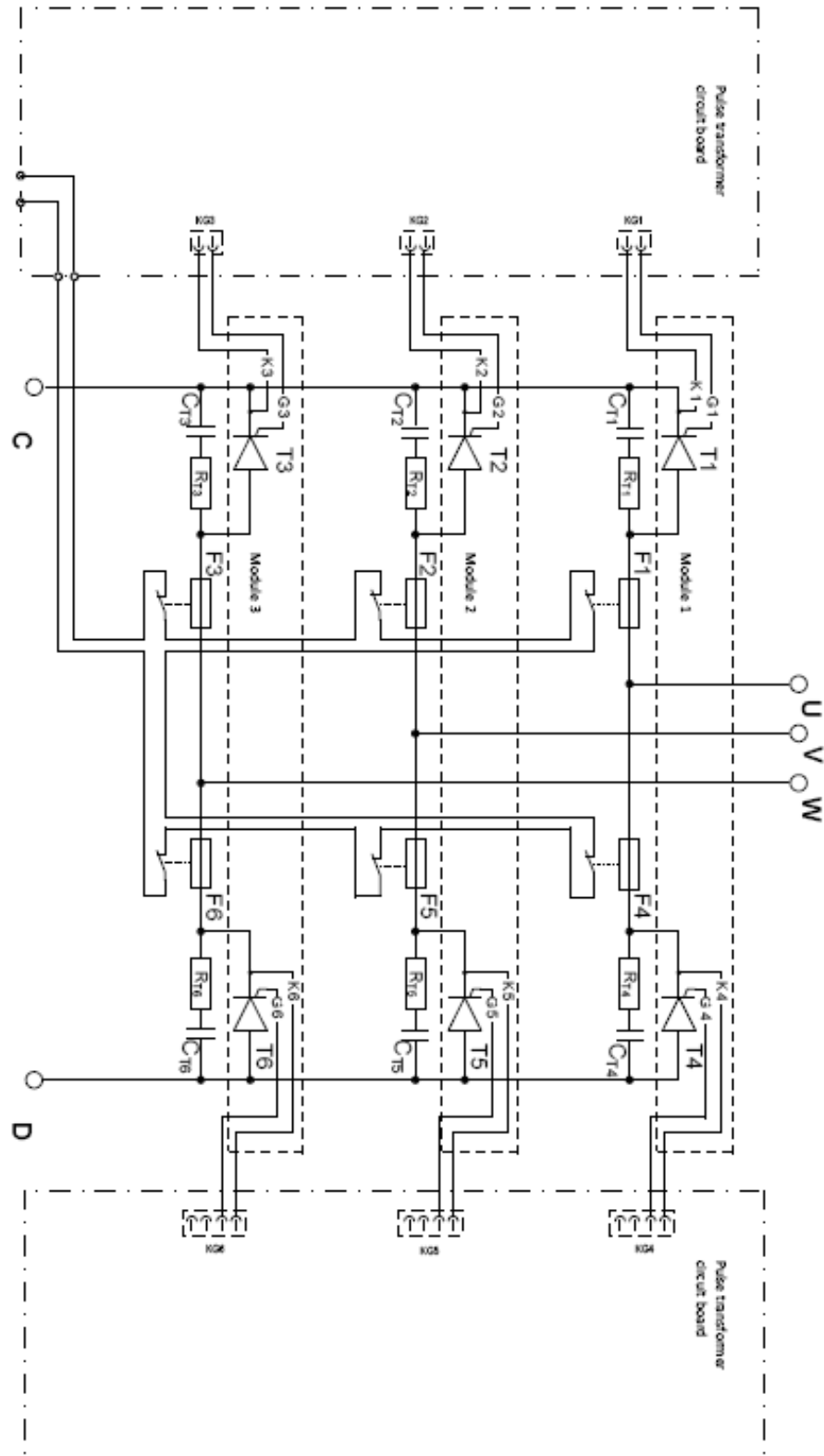

Figure 19 - AC Line Measurement Points Diagram

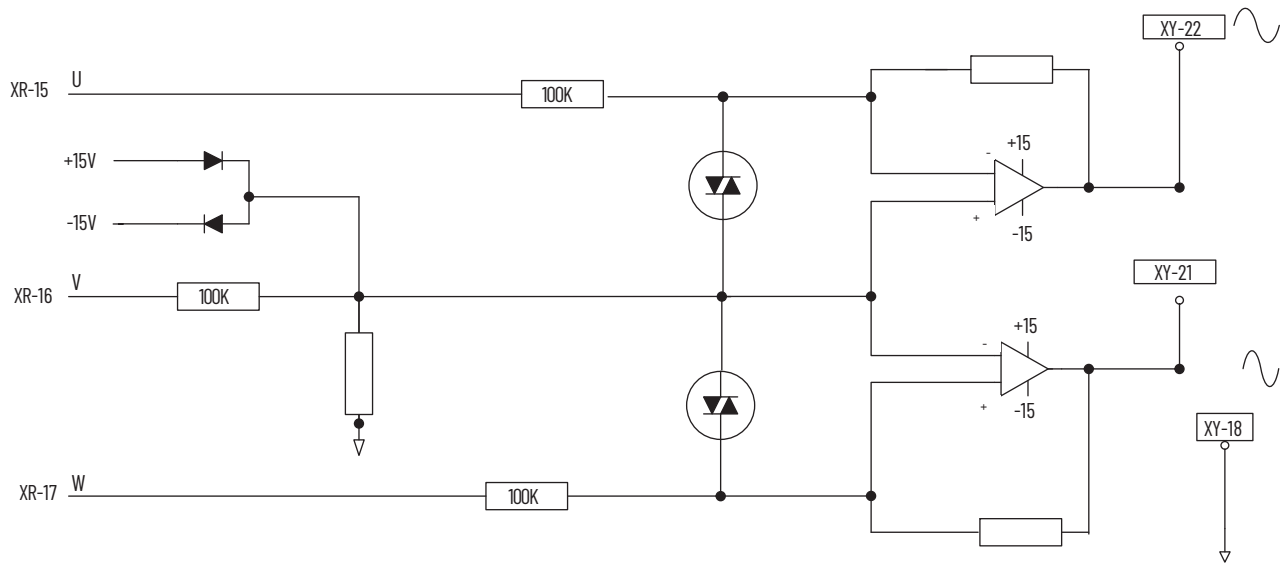

Figure 20 - Power Feedback Connections Diagram

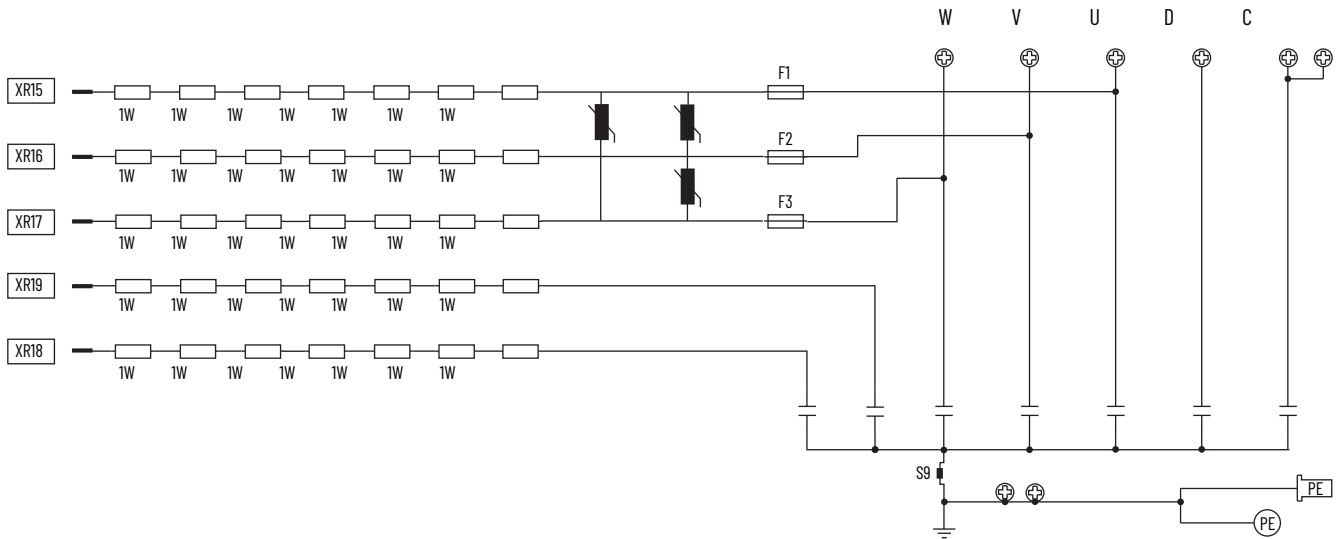

Figure 21 - Field Board and SCR/Dual Diode Module Connections Diagram

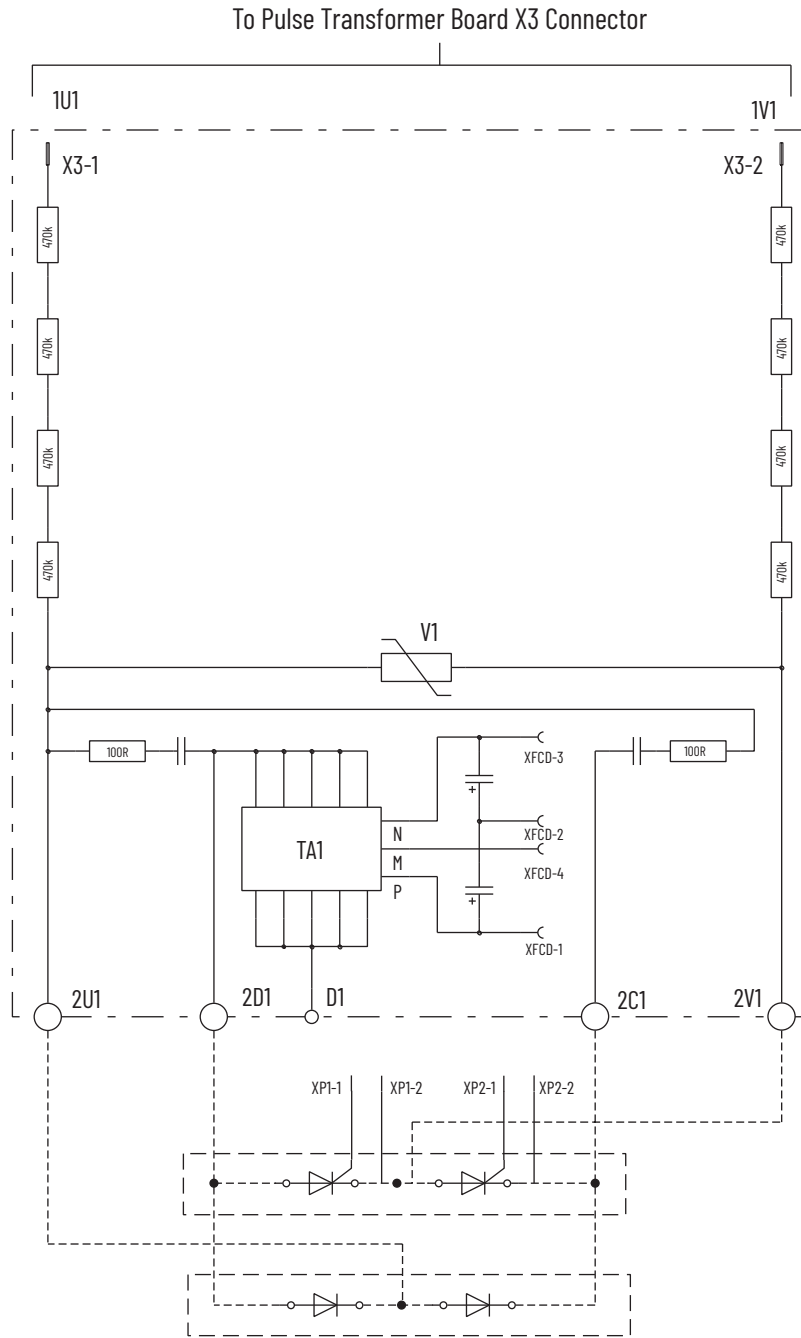

Figure 22 - Field Control Circuit Diagram

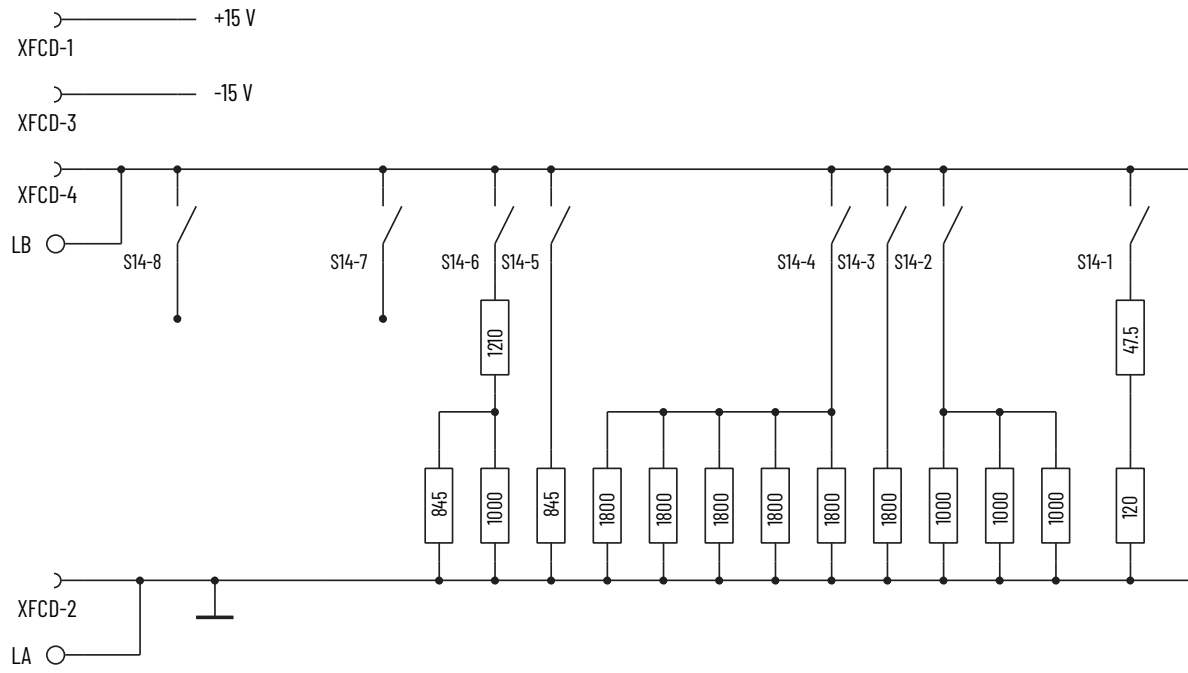

Figure 23 - Control Circuit Input Power Diagram

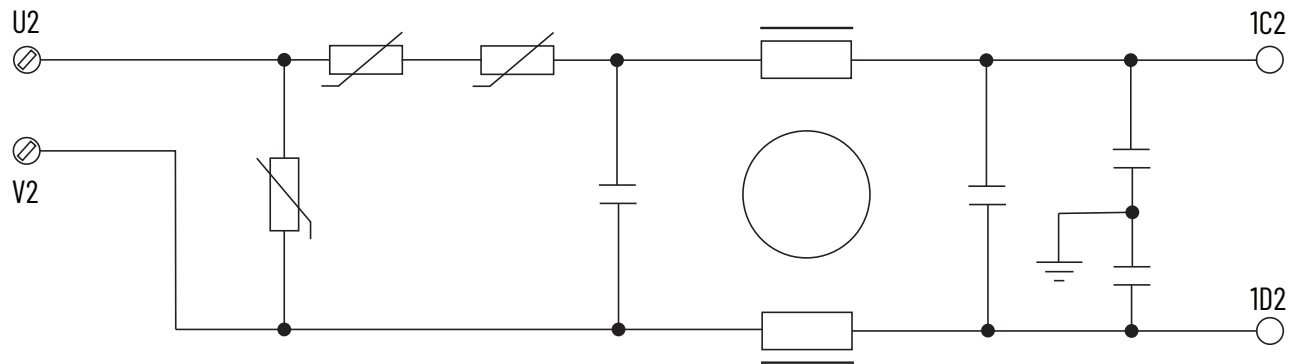

Figure 24 - Encoder Control Circuit Diagram

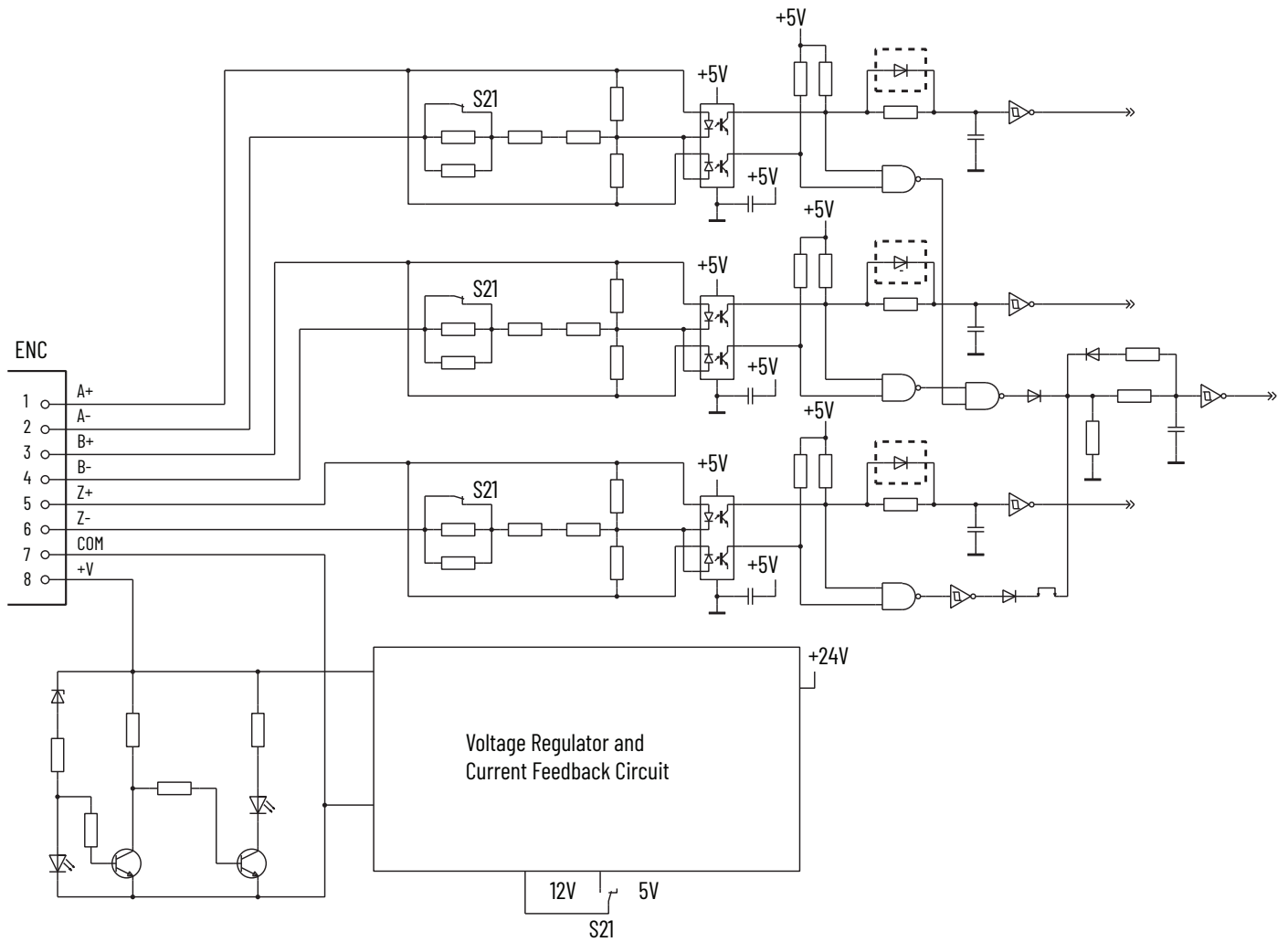

Figure 25 - DC Tachometer Control Circuit Diagram

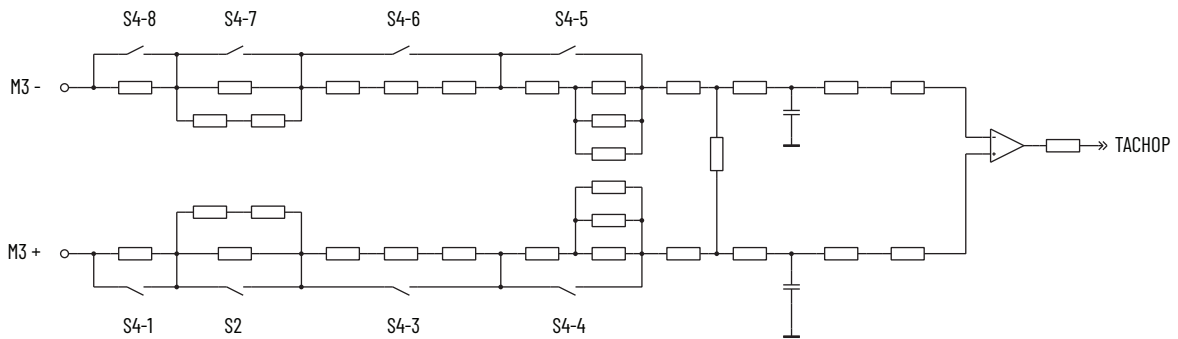

Figure 26 - Motor Thermal Protection Control Circuit Diagram

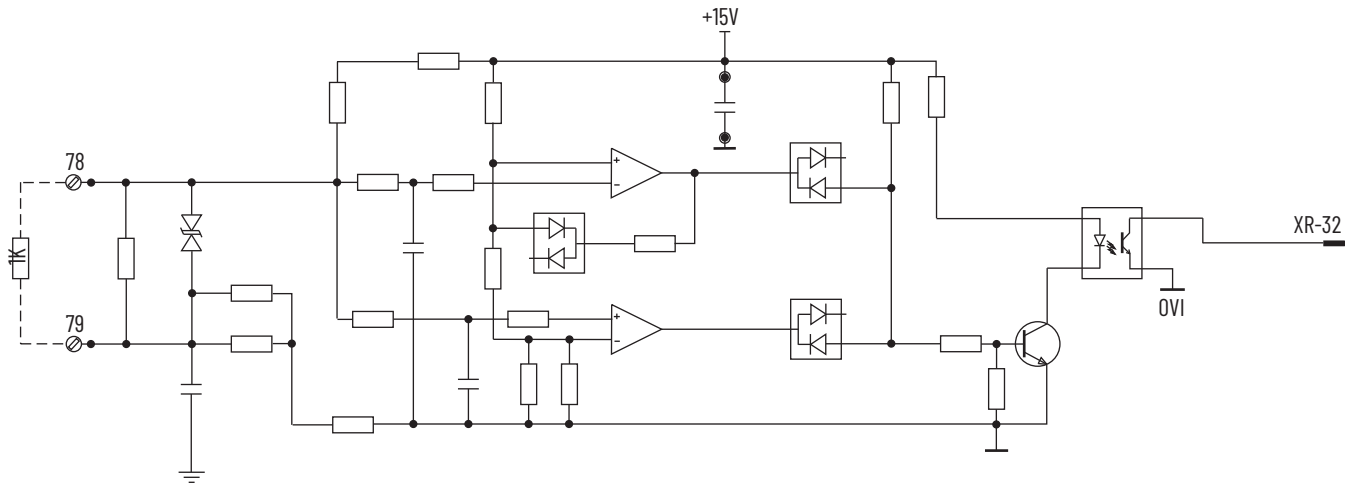

Figure 27 - Drive Heatsink Monitoring Control Circuit Diagram

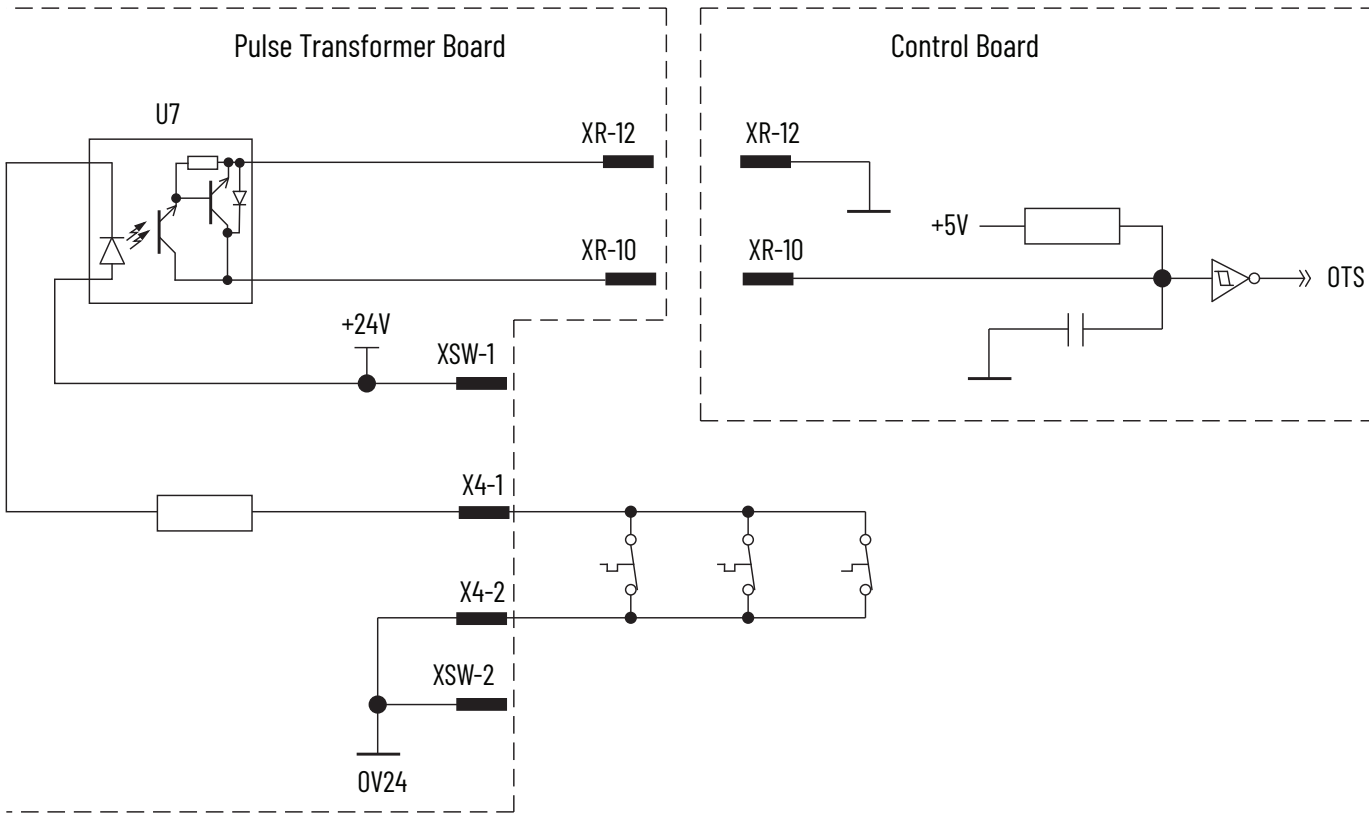

Figure 28 - Contactor Control Relays Control Circuit Diagram

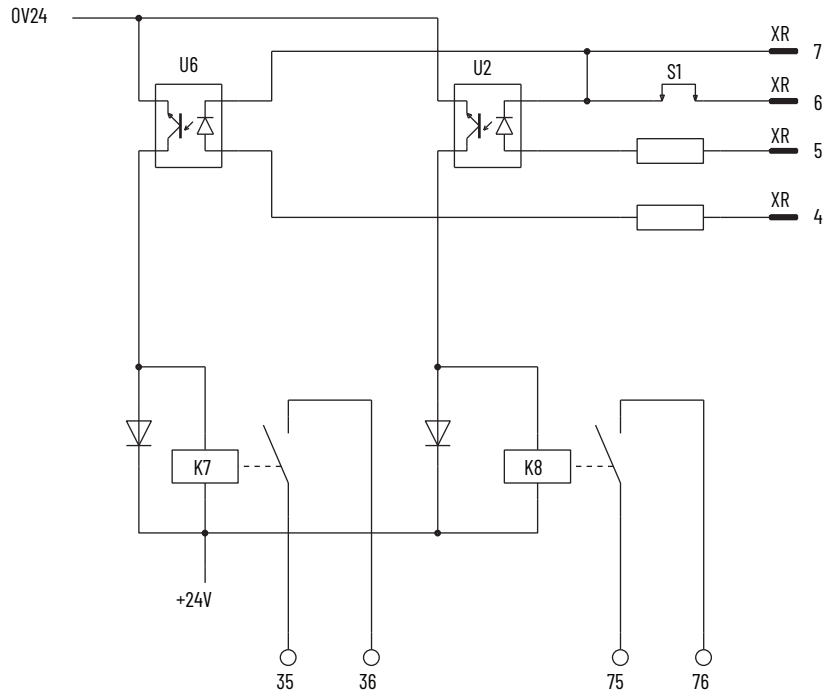
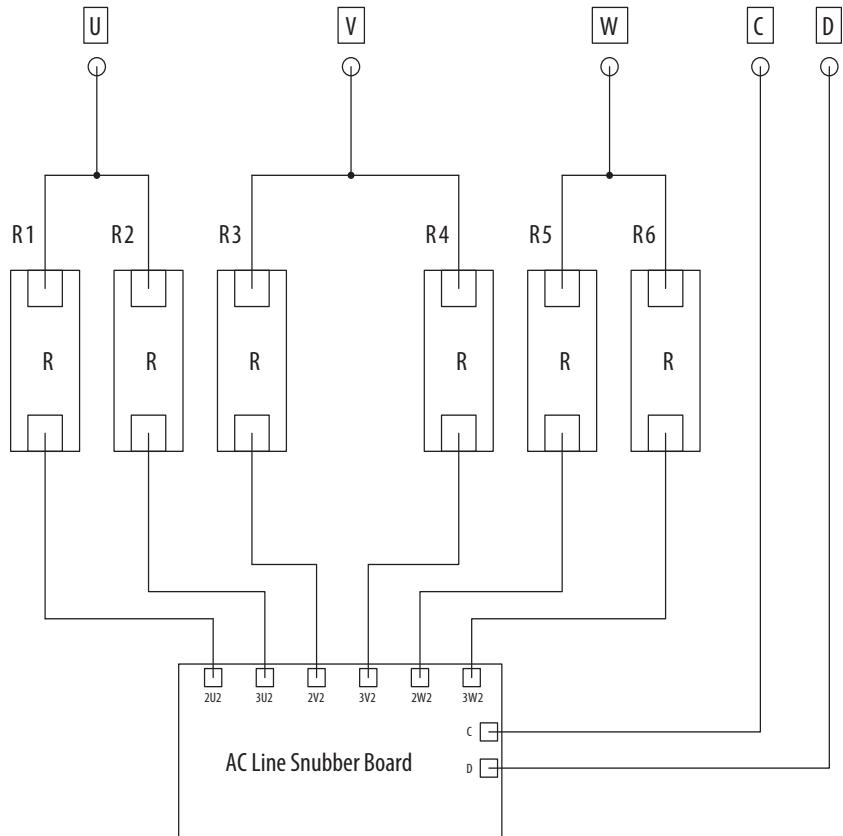

Figure 29 - AC Line Snubber Circuit



Board Layouts and Connections

List of Board Layouts

The following images and tables detail the connection points for the frame C TPDflex DC Converter circuit boards and components.

For a Schematic Diagram on	See Page
Pulse Transformer Board Layout	122
Pulse Transformer Board to Current Transducers Connections	123
Pulse Transformer Board to Bimetal Thermostats Connections	123
Pulse Transformer Board to Field SCR/Dual Diode Module Connections	123
Pulse Transformer Board to Current Transducers Connections	123
Pulse Transformer Board to Field Power Board Connections	123
Pulse Transformer Board to Control Board Connections	124
Switching Power Supply Board Layout	125
Switching Power Supply Board to Control Board Connections	125
Control Board Layout Series A	126
Control Board Layout Series B	124
Field Power Board Layout	129
Power Supply Filter Board Layout	129
Power Supply Filter Board to Pulse Transformer Board Connections	129
Power Supply Filter Board to Switching Power Supply Board Connections	129
Power Supply Filter Board to Fan Connections	130
Transient Noise Filter Board Layout	130
Transient Noise Board to Pulse Transformer Board Connections	130

Pulse Transformer Board

Figure 30 - Pulse Transformer Board Layout

FIR3 xx Re L and Lower

FIR3 xx Re M and igher

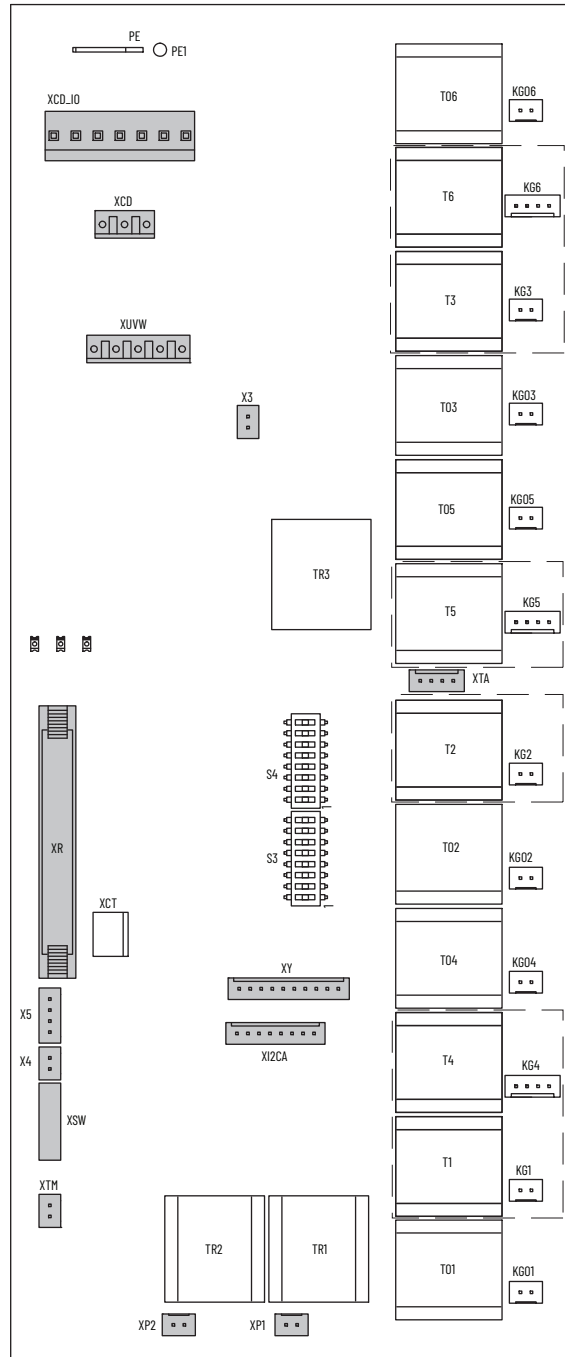
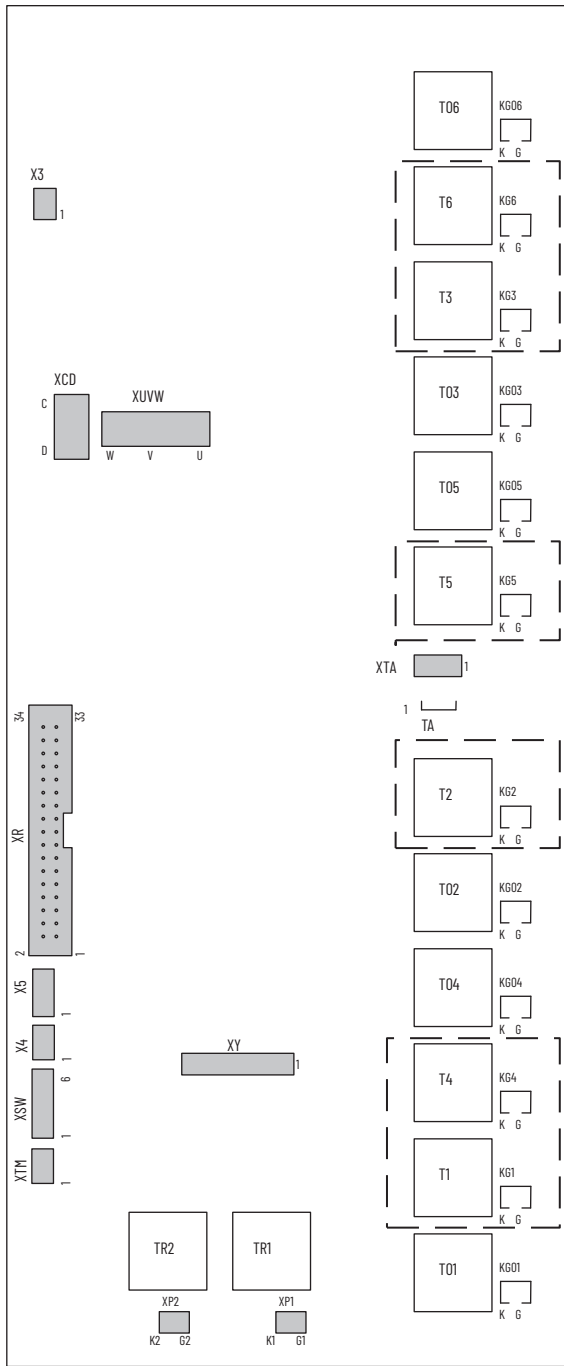

Table 21 - Pulse Transformer Board to Field Power Board Connections

Pulse Transformer Board Connector	Pin Number	to	Pin Number	Field Power Board Connector	Description
X3	1	...	1	X3	1U1 field sync signal (from U1)
	2	...	2		1V1 field sync signal (from V1)

Table 22 - Pulse Transformer Board to Bimetal Thermostats Connections

Pulse Transformer Board Connector	Pin Number	to	Bimetal Thermostat Terminals	Description
X4	1	...	e1, e2, e3	+24V supply
	2	...		24V common

Table 23 - Pulse Transformer Board to Field SCR/Dual Diode Module Connections

Pulse Transformer Board Connector	Pin Number	to	Field SCR/Dual Diode Module Connector	Description
XP1	1	...	G1	Gate signal G1
	2	...	K1	Common cathode
XP2	1	...	G2	Gate signal G2
	2	...	K2	Common cathode

Table 24 - Pulse Transformer Board to Switching Power Supply Board Connections

Pulse Transformer Board Point	Pin Number	to	Pin Number	Switching Power Supply Board Connector	Description
XSW	1	...	1	XSW	+24V supply
	2	...	2		24V common
	3	...	3		Internal 18V common
	4	...	4		
	5	...	5		Internal +18V supply
	6	...	6		

Table 25 - Pulse Transformer Board to Current Transducers Connections

Pulse Transformer Board Connector	Pin Number	Lead	to	Current Transducer Terminals	Description
XTA	1	Red	...	TA-U	Secondary side CT phase U
	2	White	...		
	3	Black	...	TA-V	Secondary side CT phase W
	4	Blue	...		

Table 26 - Pulse Transformer Board to Control Board Connections

Pulse Transformer Board Connector	Pin Number	to	Pin Number	Control Board Connector	Description
XR	1	...	1	XR	Gate signal G1 field SCR1
	2	...	2		Gate signal G2 field SCR2
	3	...	3		OV (GNDP)
	4	...	4		Relay output 35-36 command
	5	...	5		Relay output 75-76 command
	6	...	6		2Q/4Q selection signal
	7	...	7		OV (GNDP)
	8	...	8		I armature = 0 signal
	9	...	9		OV (GNDP)
	10	...	10		Heatsink overtemperature
	11	...	11		Digital U1-V1 sync signal
	12	...	12		OV (GNDP)
	13	...	13		CT burden signal
	14	...	14		OV (GND)
	15	...	15		Reduced U sync signal
	16	...	16		Reduced V sync signal
	17	...	17		Reduced W sync signal
	18	...	18		Reduced C (armature) signal
	19	...	19		Reduced D (armature) signal
	20	...	20		OV (GNDP)
	21	...	21		Gate signal SCR 4/01
	22	...	22		OV (GNDP)
	23	...	23		Gate signal SCR 5/02
	24	...	24		OV (GNDP)
	25	...	25		Gate signal SCR 6/03
	26	...	26		WH1 (not used, grounded)
	27	...	27		Gate signal SCR 1/04
	28	...	28		WL1 (not used, grounded)
	29	...	29		Gate signal SCR 2/05
	30	...	30		OV (GNDP)
	31	...	31		Gate signal SCR 3/06
	32	...	32		Motor overtemperature
	33	...	33		Enable reverse (MN) power bridge
	34	...	34		Enable forward (MP) power bridge

For connector X5 and XTM signals, see [Table 31 - Power Supply Filter Board to Pulse Transformer Board Connections on page 129](#).

For connector XCD and XUVW signals, see [Table 34 - Transient Noise Board to Pulse Transformer Board Connections on page 130](#).

Switching Power Supply Board

Figure 31 - Switching Power Supply Board Layout

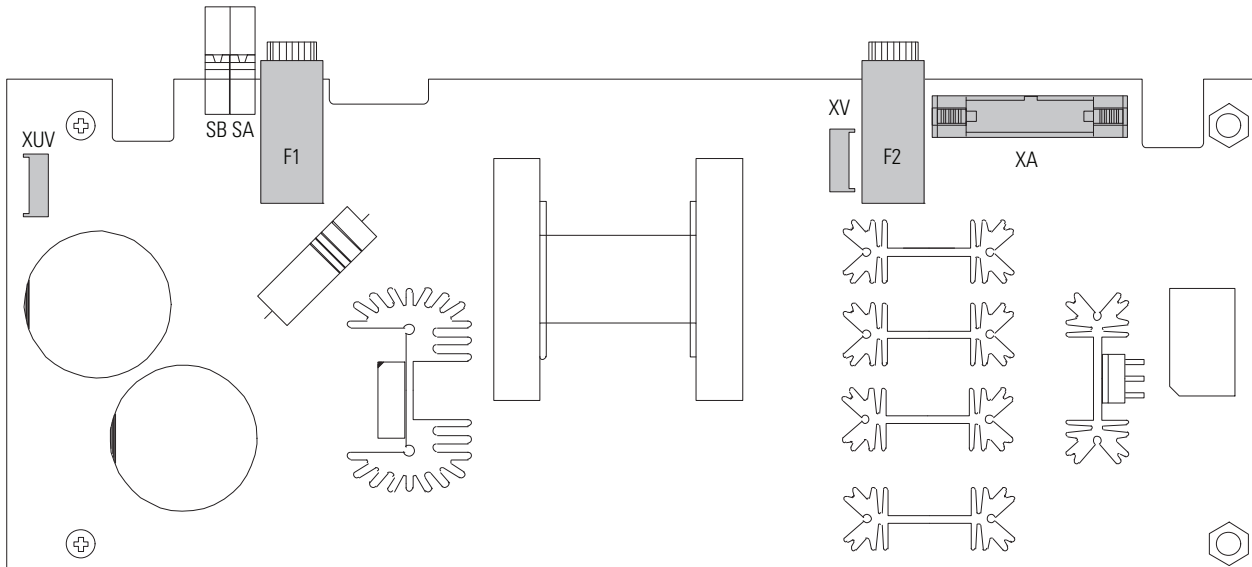

Table 27 - Switching Power Supply Board to Control Board Connections

Switching Power Supply Board Connector	Pin Number	to	Pin Number	Control Board Connector	Description
XA	1	...	1	XA	+5V
	2	...	2		5V common
	3	...	3		+5V
	4	...	4		5V common
	5	...	5		+5V
	6	...	6		5V common
	7	...	7		-
	8	...	8		-
	9	...	9		-
	10	...	10		+15V
	11	...	11		-
	12	...	12		15V common
	13	...	13		-
	14	...	14		-15V
	15	...	15		24V common
	16	...	16		+24V

Control Board

Figure 32 - Control Board Layout Series A

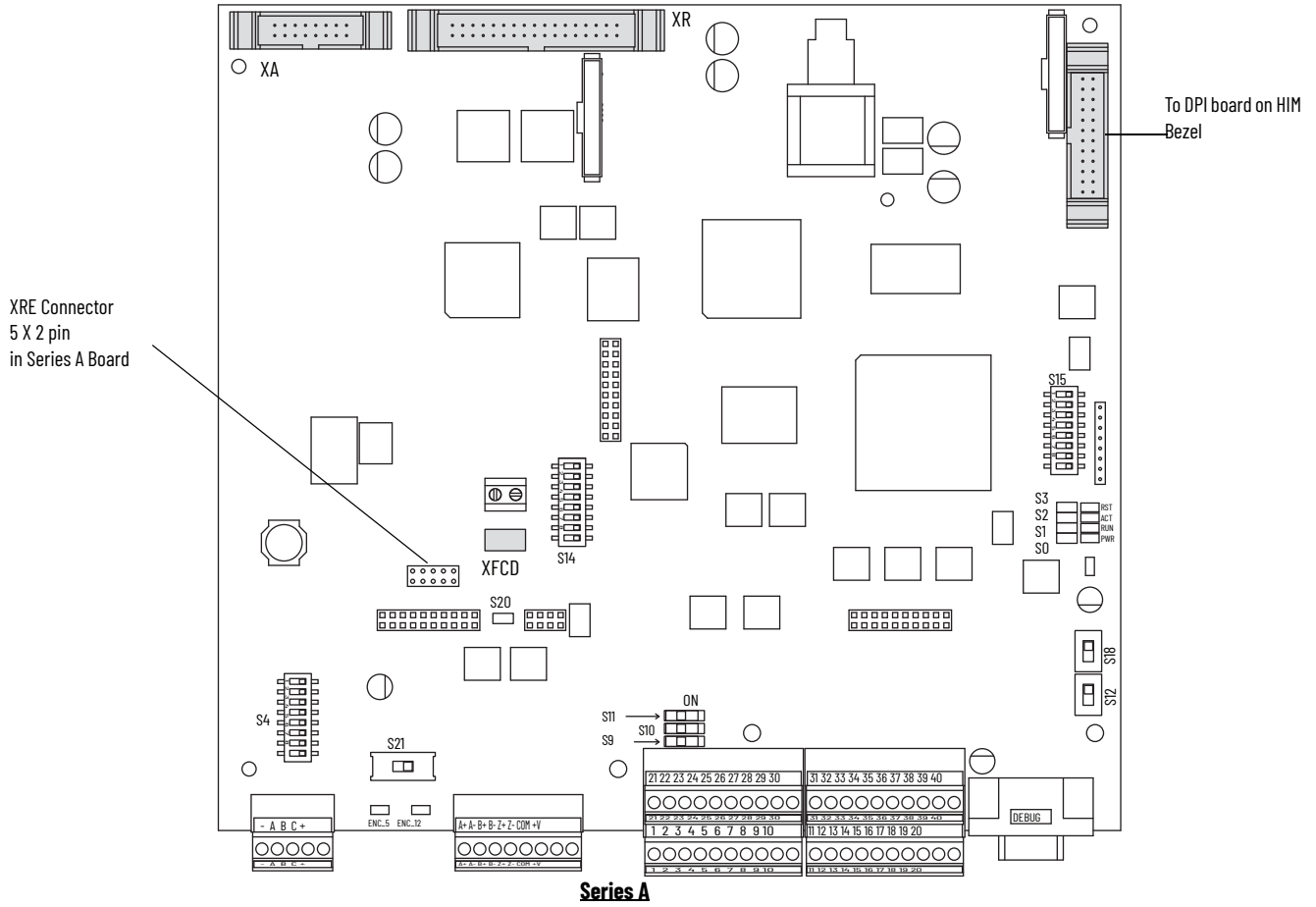

Figure 33 - Control Board Layout Series B

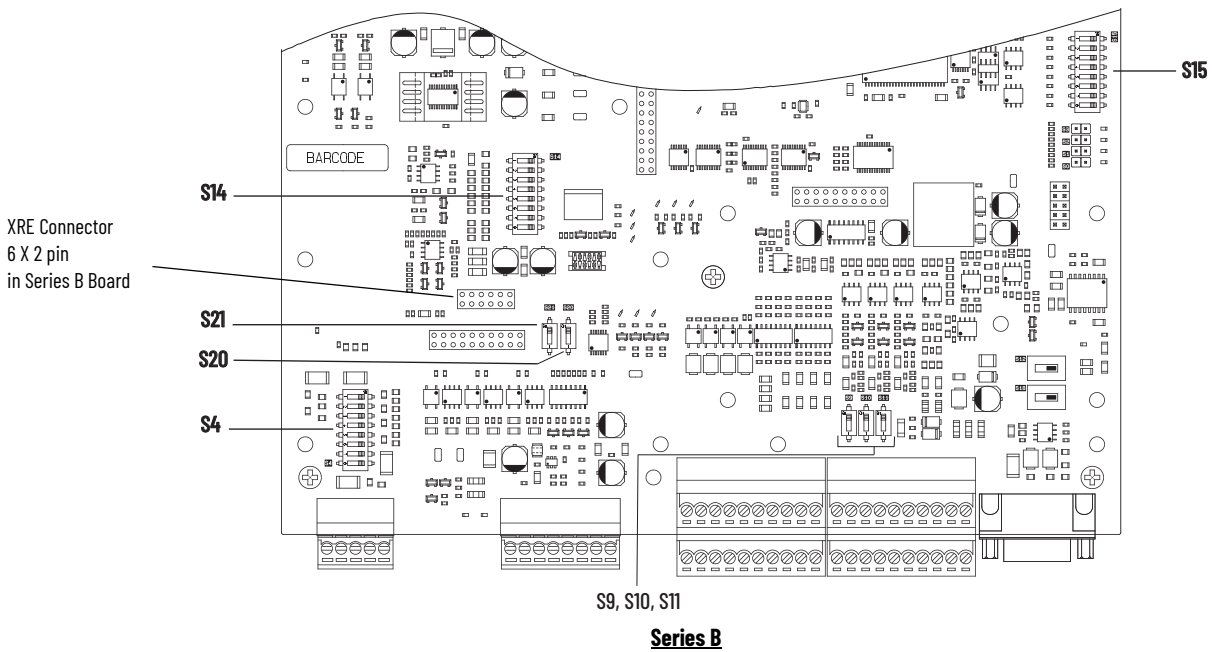

Table 28 - Series A Jumper Switch function and settings



ID	Jumper Switch	Function	Factory Default	Example
①	S0	For factory boot flashing only. Leave set to the factory setting. Jumper On Firmware boot Jumper Off Normal function	Jumper Off	
	S1	For factory boot flashing only. Leave set to the factory setting. Jumper On Write firmware boot code Jumper Off Boot code on flash is protected	Jumper Off	
	S2	Not used. Leave set to the factory setting.	Jumper Off	
	S3	For factory boot flashing only. Leave set to the factory setting. Jumper On Reset Jumper Off Normal function	Jumper Off	
②	S4	Configures the input voltage of the DC analog tachometer. See Table 28 on page 80 for configuration.	90V	...
③	S9	Configures the input signal of Analog Input 1 (terminals 1 and 2): Position Off 0...20 mA / 4...20 mA Position On 0...10V / ±10V Par 71 [Anlg In1 Config] must be programmed to match the input signal type selected with this switch.	0n	
	S10	Configures the input signal of Analog Input 2 (terminal 3 and 4): Position Off 0...20 mA / 4...20 mA Position On 0...10V / ±10V Par 76 [Anlg In2 Config] must be programmed to match the input signal type selected with this switch.	0n	
	S11	Configures the input signal of Analog Input 3 (terminals 5 and 6): Position Off 0...20 mA / 4...20 mA Position On 0...10V / ±10V Par 81 [Anlg In3 Config] must be programmed to match the input signal type selected with this switch.	0n	
④	S12	Not used. Leave set to the factory setting.	Off	...
⑤	S14	Field current resistors setting, see Field Current Configuration on page 62. The value that is selected with switch S14 must be entered in Par 374 [Drv Fld Brdg Cur] when the drive is commissioned. For permanent magnet motor or external field controller applications, leave set to the factory default settings.	Minimum field current rating based on the drive size.	...
⑥	S15	Configuration of the control circuit board to the appropriate drive size. Leave set to the factory setting, unless the control board has been supplied as a spare part. See DIP Switch S15 Settings on page 80 for switch configuration that is based on drive current rating code.	Armature current based on drive size.	...
⑦	S18	Not used. Leave set to the factory setting.	Off	...
⑧	S20	Monitoring (reported by Par 652 [Encoder Err Chk]) of the Z channel of the Digital Encoder on connector XE2. This switch adds/removes the Z channel in the encoder hardware check circuit. Par 652 enables/disables reading the result of that hardware check. Position Off Z channel monitored Position On Z channel not monitored	0n	
⑨	S21	Encoder power supply voltage and input selection: This switch setting determines both the power supply (input) and feedback level (output) voltage of the connected encoder. When control power is supplied to the drive, the appropriate LED lights to indicate the selection of the switch. ENC_5 +5V encoder (2.5...5.4V input range) ENC_12 +12...15V encoder (+5.4V...15.2V input range)	12...15V	

Table 29 - Series B Jumper Switch function and settings



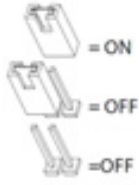

ID	Jumper Switch	Function	Factory Default	Example
1	S0	Not used. Leave set to the factory setting.	Jumper Off	
	S1	Not used. Leave set to the factory setting.	Jumper Off	
	S2	For factory boot flashing only. Leave set to the factory setting. Jumper On Boot mode Jumper Off Normal function	Jumper Off	
	S3	For factory boot flashing only. Leave set to the factory setting. Jumper On Reset Jumper Off Normal function	Jumper Off	
2	S4	Configures the input voltage of the DC analog tachometer. See Table 28 on page 80 for configuration.	90V	...
3	S9	Configures the input signal of Analog Input 1 (terminals 1 and 2): Position On 0...20 mA / 4...20 mA Position Off 0...10V / ±10V Par 71 [Anlg In1 Config] must be programmed to match the input signal type selected with this switch.	Off	
	S10	Configures the input signal of Analog Input 2 (terminal 3 and 4): Position On 0...20 mA / 4...20 mA Position Off 0...10V / ±10V Par 76 [Anlg In2 Config] must be programmed to match the input signal type selected with this switch.	Off	
	S11	Configures the input signal of Analog Input 3 (terminals 5 and 6): Position On 0...20 mA / 4...20 mA Position Off 0...10V / ±10V Par 81 [Anlg In3 Config] must be programmed to match the input signal type selected with this switch.	Off	
4	S12	Not used. Leave set to the factory setting	Off	...
5	S14	Field current resistors setting, see Field Current Configuration on page 62. The value that is selected with switch S14 must be entered in Par 374 [Drv Fld Brdg Cur] when the drive is commissioned. For permanent magnet motor or external field controller applications, leave set to the factory default settings.	Minimum field current rating based on the drive size.	...
6	S15	Configuration of the control circuit board to the appropriate drive size. Leave set to the factory setting, unless the control board has been supplied as a spare part. See DIP Switch S15 Settings on page 80 for switch configuration that is based on drive current rating code.	Armature current based on drive size.	...
7	S18	Not used. Leave set to the factory setting.	Off	...
8	S20	Monitoring (reported by Par 652 [Encoder Err Chk]) of the Z channel of the Digital Encoder on connector XE2. This switch adds/removes the Z channel in the encoder hardware check circuit. Par 652 enables/disables reading the result of that hardware check. Position On Z channel monitored Position Off Z channel not monitored	Off	
9	S21	Encoder power supply voltage and input selection: This switch setting determines both the power supply (input) and feedback level (output) voltage of the connected encoder. When control power is supplied to the drive, the appropriate LED lights to indicate the selection of the switch. Position On +12...15V encoder (+5.4V...15.2V input range) Position Off +5V encoder (2.5...5.4V input range)	12...15V	

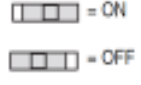
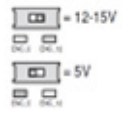
Table 30 - Control Board to Field Board Connections

Control Board Connector	Pin Number	to	Pin Number	Field Board Connector	Description
XFCD	1	...	1	XFCD	+15V
	2	...	2		15V Common
	3	...	3		-15V
	4	...	4		Field CT burden resistors

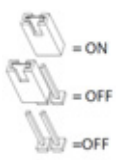
For connector XA signals, see [Table 27 - Switching Power Supply Board to Control Board Connections on page 125](#).

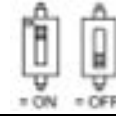
Field Power Board

Figure 34 - Field Power Board Layout

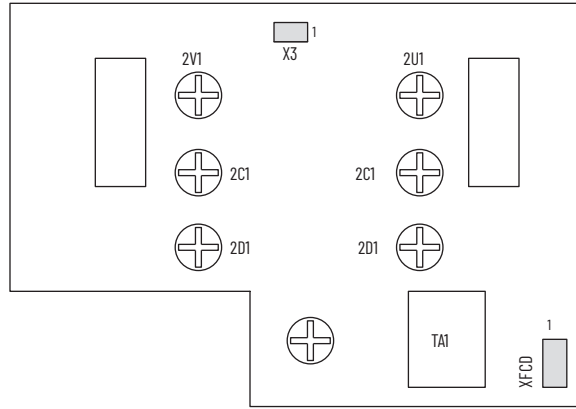

For connector X3 signal, see [Table 21 - Pulse Transformer Board to Field Power Board Connections on page 123](#). For connector XFCD signal, see [Table 33 - Control Board Layout Series B on page 126](#).

Figure 35 - Power Supply Filter Board Layout

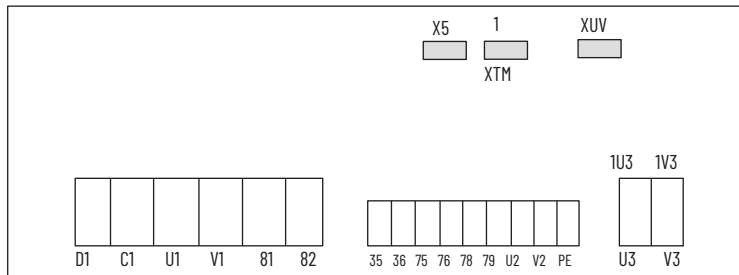

Table 31 - Power Supply Filter Board to Pulse Transformer Board Connections

Power Supply Filter Board Connector	Pin Number	to	Pin Number	Pulse Transformer Board Connector	Description
X5	1	...	1	X5	24V common
	2	...	2		+24V supply
	3	...	3		(not used)
	4	...	4		
XTM	1	...	1	XTM	250V AC maximum (from motor PTC)
	2	...	2		

Table 32 - Power Supply Filter Board to Switching Power Supply Board Connections

Power Supply Filter Board Connector	Pin Number	to	Pin Number	Switching Power Supply Board Connector	Description
XUV	1	...	1	XUV	Single phase 115V / 230V AC
	2	...	2		(Not used)
	3	...	3		
	4	...	4		Single phase 115V / 230V AC

Table 33 - Power Supply Filter Board to Fan Connections

Power Supply Filter Board Connector	to	Fan Terminal Block	Description
1V3, 1U3	...	-	Single phase 115V / 230V AC

Figure 36 - Transient Noise Filter Board Layout

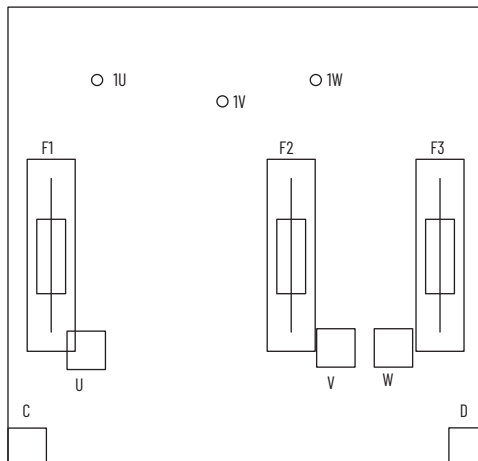

Table 34 - Transient Noise Board to Pulse Transformer Board Connections

Transient Noise Filter Board Connector	to	Pin Number	Pulse Transformer Board Connector	Description
1U	...	1	XUVW	Phase U signal
1V	...	2		Phase V signal
1W	...	3		Phase W signal
C	...	1	XCD	Armature C signal
D	...	2		Armature D signal

Flow Charts

List of Flow Charts

The following pages contain flow chart versions of troubleshooting procedures contained in Chapter 2 - Component Test Procedures.

Topic	Page
Control Power Supply Failure	132
Field Current Loss Failure	133

Control Power Supply Failure

This chart presents the steps for troubleshooting a Power Failure fault (F3).

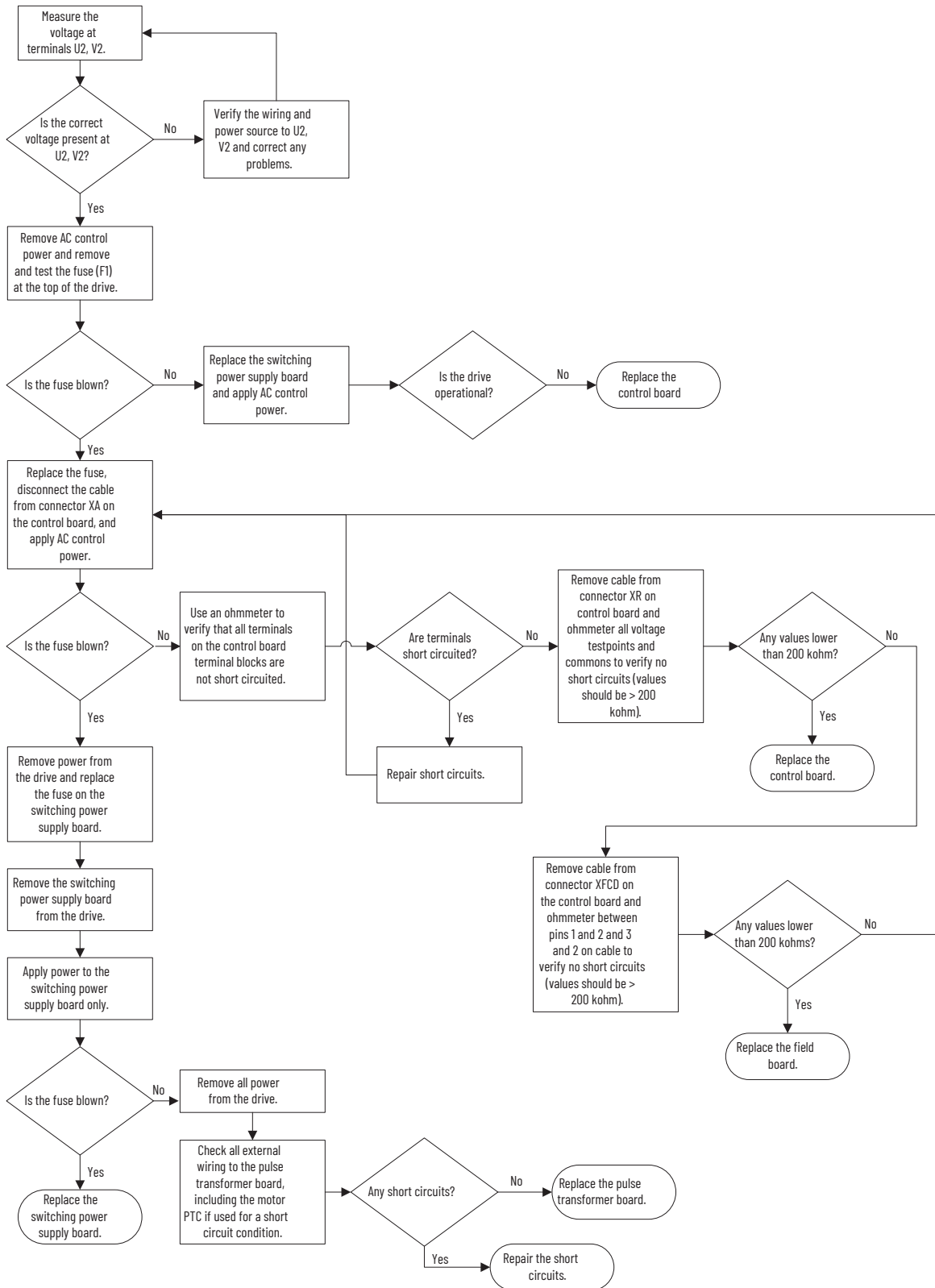

Field Current Loss Failure

The charts below presents the steps in flow chart form for troubleshooting a Field Current Loss fault (F6).

No Field Current

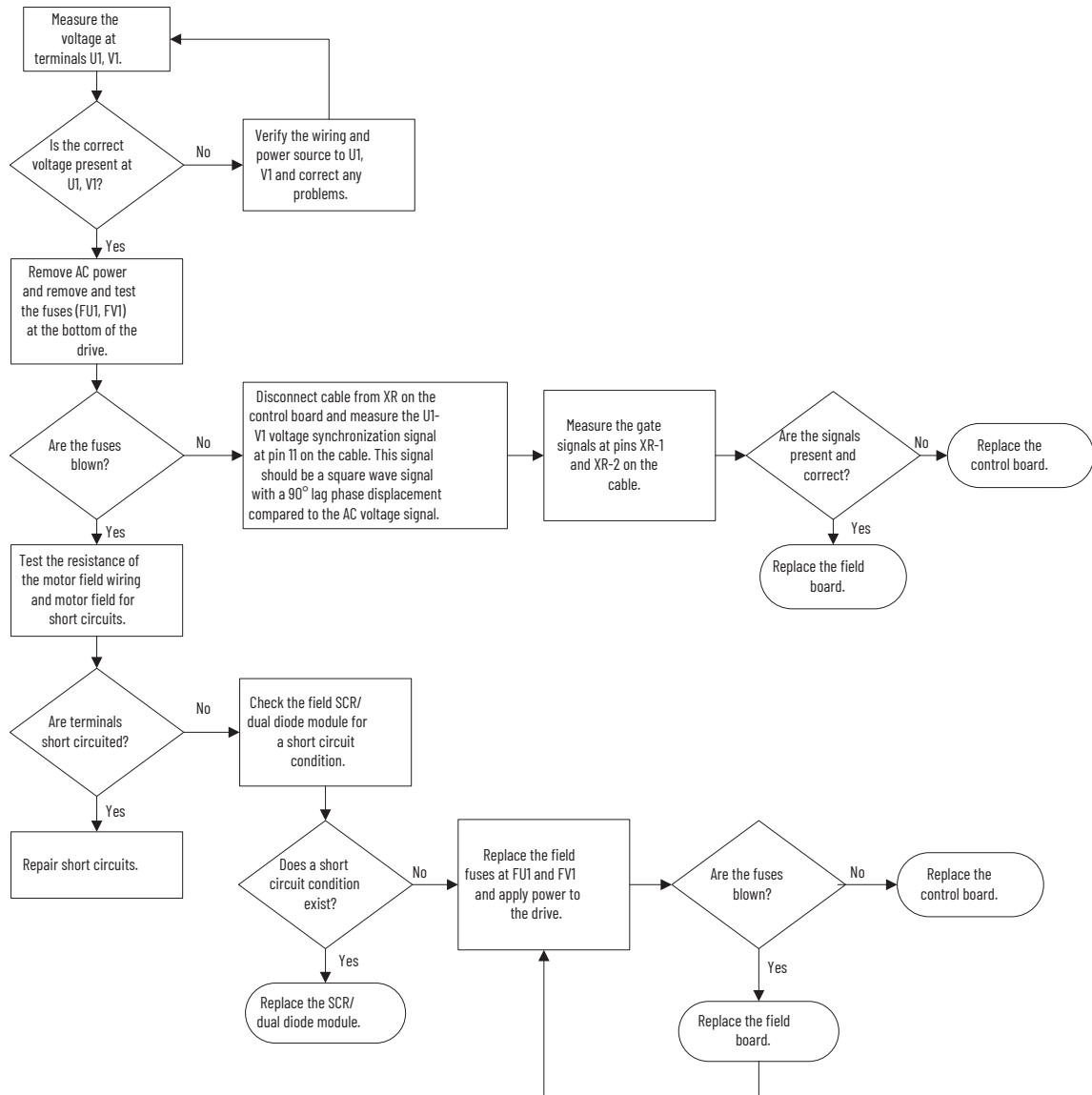

Low or Incorrect Field Current

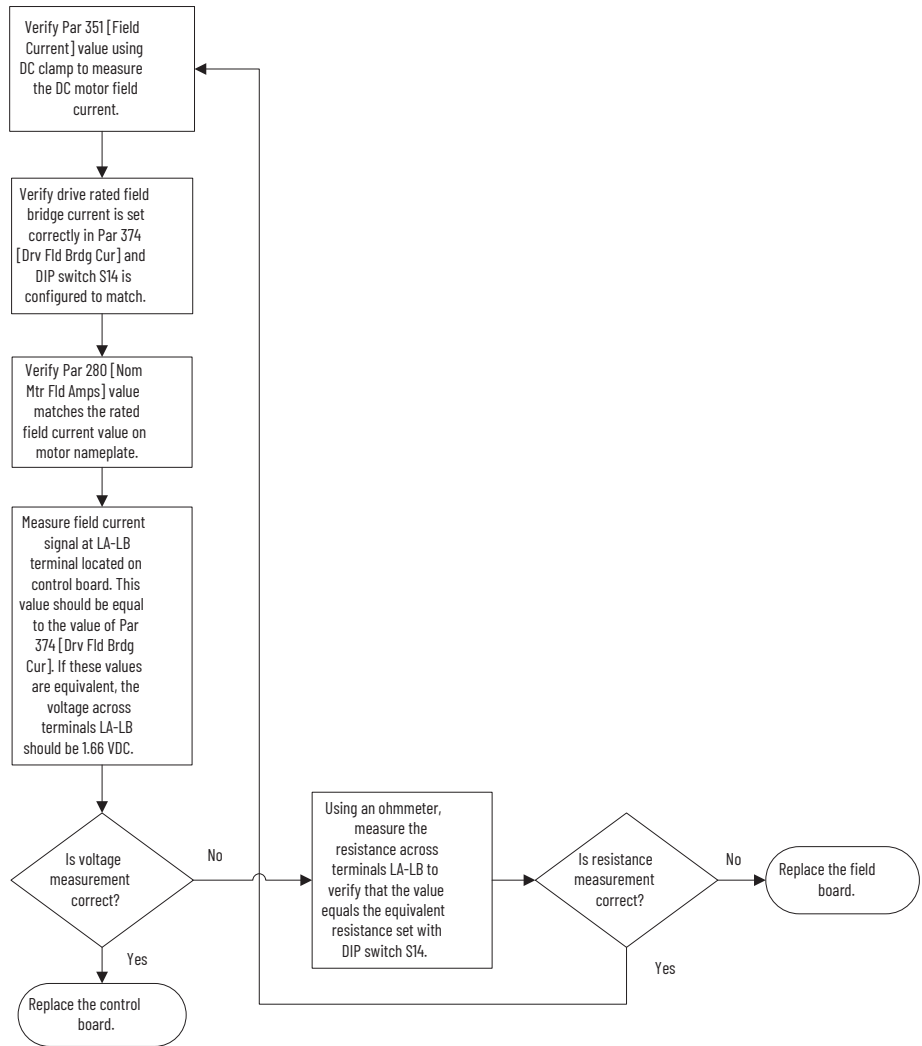

A**AC current transducers**

install 98
remove 93

AC line snubber board and resistors

install 74
remove 68

armature bridge failure

troubleshoot 21

armature leg fuses

install 85
remove 82

armature SCR modules

test 27

B**bimetal thermostats**

install 106
remove 98

C**circuit board**

connections 121
layouts 121

communication adapter and EMI shield

install 46
remove 43

components

inspection 14

configure

pulse transformer board 61
sizing resistors 62

contactor fault 37**control circuit board**

install 54
remove 51

control EMI shield

move 54

control power supply

failure 14

cooling fans

install 108
remove 107

D**DC analog tachometer**

test 35

DIP switches

S3, S4 64

download parameter configuration 14**DPI/ IM assembly**

install 41
remove 40

E**Electrostatic Discharge Precaution 9****encoder**

test 35

F**fault**

field current loss 24
heatsink overtemperature 37
main contactor 37
overcurrent 21
power failure 14

fault report

create 37

field circuit fuses

install 43
remove 43

field current loss fault 24**field power board**

install 66
remove 65

field SCR and dual diode module

install 67
remove 66

field SCR/dual diode module

test 32

frame size 10**H****hardware description 10****heatsink overtemperature**

fault 37

I**I/O controller circuit board**

install 51
remove 50

I/O expansion circuit board

install 50
remove 48

inspection

visual 14

install

- AC current transducers 98
- AC line snubber board and resistors 74
- armature leg fuses 85
- bimetal thermostats 106
- communication adapter and EMI shield 46
- control circuit board 54
- cooling fans 108
- DPI/HIM assembly 41
- field circuit fuses 43
- field power board 66
- field SCR and dual diode module 67
- I/O converter circuit board 51
- I/O expansion circuit board 50
- power supply filter board 81
- protective covers 43
- pulse transformer board 65
- resolver feedback circuit board 48
- resolver interface circuit board 48
- SCR modules 92
- switching power supply board 58
- switching power supply board fuses 56
- transient noise filter board 79
- transient noise filter board fuses 75

M**motor overheating** 37**move**

- control EMI shield 54

O**outputs**

- relay 37

overcurrent fault 21**overtemperature**

- heatsink 37

P**parameter configuration**

- download 14
- save 13

power failure fault 14**power supply filter board**

- install 81
- remove 79

protective covers

- install 43
- remove 41

PTC 37**pulse transformer board**

- configure 61
- install 65
- remove 58
- test 31

R**relay outputs** 37**remove**

- AC current transducers 93
- AC line snubber board and resistors 68
- armature leg fuses 82
- bimetal thermostats 98
- communication adapter and EMI shield 43
- control circuit board 51
- cooling fans 107
- DPI/HIM assembly 40
- field circuit fuses 43
- field power board 65
- field SCR and dual diode module 66
- I/O converter circuit board 50
- I/O expansion circuit board 48
- power supply filter board 79
- protective covers 41
- pulse transformer board 58
- resolver feedback circuit board 46
- resolver interface circuit board 46
- SCR modules 85
- switching power supply board 57
- switching power supply board fuses 56
- transient noise filter board 75
- transient noise filter board fuses 74

resolver feedback circuit board

- install 48
- remove 46

resolver interface circuit board

- install 48
- remove 46

S**safety precautions** 9**save parameter configuration** 13**SCR modules**

- install 92
- remove 85

service tools 11**setting**

- DIP switches (S3, S4) 64

sizing resistors

- configure 62
- total resistance values 63

software tools 11**switching power supply board**

- install 58
- remove 57

switching power supply board fuses

- install 56
- remove 56

T**technical support**

- calling 37

test

- armature SCR modules 27
- DC analog tachometer 35
- encoder 35
- field SCR/dual diode module 32
- pulse transformer board 31

testpoints

- locations 17

thermal switch 37**thermistor** 37

tools

- service 11
- software 11

total resistance values

- sizing resistors 63

transient noise filter board

- install 79
- remove 75

transient noise filter board fuses

- install 75
- remove 74

troubleshoot

- armature bridge failure 21
- field current loss 24
- overcurrent fault 21
- power failure fault 14

V**Visual inspection 14**

Do you need help?

This drive is available exclusively through **Allen-Bradley distributors** and **Rockwell Automation drive systems**. If there are any questions, please contact your local **Allen-Bradley distributor** or **Rockwell Automation sales office**.

Support is offered by the **Rockwell Automation** TechConnect services, field service teams, product repair services and spare part availability.

Rockwell Automation support

Use these resources to access support information.

Technical Support Center	Find help with how-to videos, FAQs, chat, user forums, Knowledgebase, and product notification updates.	rok.auto/support
Local Technical Support Phone Numbers	Locate the telephone number for your country.	rok.auto/phonesupport
Product Compatibility and Download Center (PCDC)	Download firmware, associated files (such as AOP, EDS, and DTM), and access product release notes.	rok.auto/pcdc
Distributor Partner Locator	Rockwell Automation partners with best-in-class partners worldwide to offer first-rate solutions for your business challenges. Search our Partner-Network database and connect with a partner today.	rockwellautomation.com/en-us/sales/partner-locator

Documentation Feedback

Your comments help us serve your documentation needs better. If you have any suggestions on how to improve our content, contact us at techdoc@weq.net.

Waste Electrical and Electronic Equipment (WEEE)



At the end of life, this equipment should be collected separately from any unsorted municipal waste.

Hardware Service Manual

Series: TPDflex

Revision: 0.1

Date: 10/02/2026

Codice: 1S7TFLEXC

WEG Automation Europe S.r.l.

Via Giosuè Carducci, 24

21040 Gerenzano (VA) · Italy

info.motion@weg.net

Technical Assistance: technohelp@weg.net

Customer Service: salesmotion@weg.net