

Industrial Motors  
Commercial &  
Appliance Motors  
Automation  
Digital &  
Systems  
**Energy**  
Transmission &  
Distribution  
Coatings

# SYNCHRONOUS MOTORS

Optimized projects  
to ensure **maximum  
efficiency**

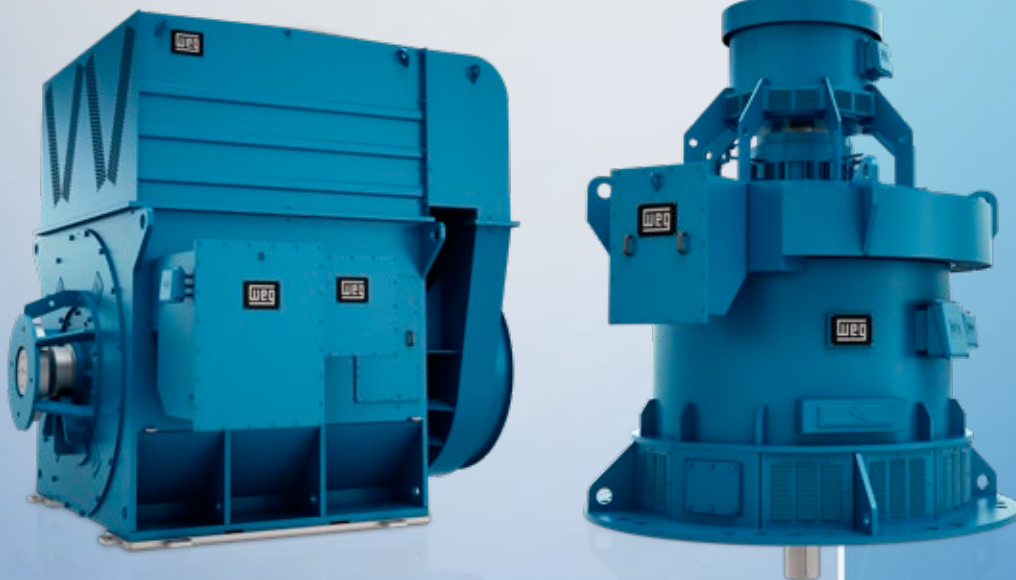

Driving efficiency and sustainability



# Synchronous motors

WEG offers complete industrial solutions, providing the market with products developed along with specialized international consulting companies. Among the products, synchronous motors stand out as they are being increasingly more used in a variety of applications due to their special operating characteristics. High efficiency, power factor correction, high torques and low starting currents, constant speed under load variations, low operating and maintenance costs are the main reasons why synchronous motors are the most indicated drive for different types of applications.



## Certifications/standards

WEG quality system is audited and certified by the Bureau Veritas Quality Institute in accordance with the requirements of ISO 9001 and ISO 14001. In order to meet the requirements of the world's most demanding markets, WEG motors present significant certifications from important certifying bodies, such as: CSA, BVQI, ABS and DNV.

- Outputs: up to 150,000 kW
- Voltages: up to 13,800 V
- Speeds: 3,600 to 150 rpm



## Projects

WEG products are designed with modern software applications, developed with collaboration of European, American and Brazilian universities, ensuring optimized projects and maximum product performance.

# Why using synchronous motors??

The application of synchronous motors in industry most often results in considerable economic and operational advantages caused by their performance characteristics. The main advantages are:

## Power factor correction

Synchronous motors can help to reduce electric energy costs and to improve the efficiency of the power system by supplying reactive energy to the grid they are connected. In a few years, the electric energy savings can pay off the amount invested in the motor.

## Constant speed

Synchronous motors are capable of maintaining constant speed operation under overload conditions and/or during voltage variations, observing the limits of maximum torque (pull-out).

## High torque capacity

Synchronous motors are designed with high overload capability, maintaining constant speed even in applications with great load variations.

## High efficiency

Synchronous motors are designed to provide high efficiency under a large range of operational conditions providing significant savings with energy costs along its lifetime.

## Greater stability in the operation with frequency inverters

Synchronous motors can operate in a wide speed range, while maintaining stability regardless of load variation (e.g.: rolling mill, plastic extruder, among others).

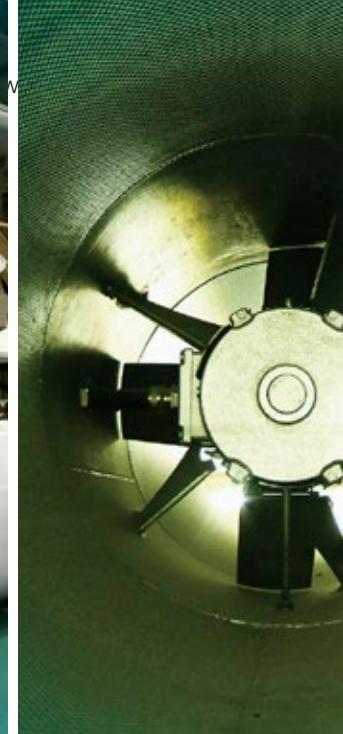

## Applications

WEG synchronous motors are specially designed and manufactured to meet the requirements of each application. Due to their construction features, operation with high performance and adaptability to all types of environment, they can be used in all industry sectors:

- Mining (crushers, grinding mills, belt conveyors and others)
- Iron and steel (rolling mills, fans, pumps and compressors)
- Paper and cellulose (extruders, chippers, shredders, compressors, peelers and refiners)
- Sanitation (pumps)
- Chemical and petrochemical industry (compressors, fans, exhausters and pumps)
- Cement (crushers, mills and belt conveyors)
- Rubber (extruders, mills and mixers)
- Energy transmission (synchronous condensers)



Synchronous motors SEF900 (Ex-p), 3,600 kW, 13,200 V  
Application: reciprocating compressors (petrochemicals)



Synchronous motors SDL800, 3,000 kW, 3,100 V  
Application: rolling mills (iron and steel)

### Synchronous motors for hazardous atmospheres

For applications in hazardous atmospheres, WEG manufactures motors with specific safety features, able to operate in locations where flammable products are continuously handled, processed or stored. WEG synchronous motors can be provided with Ex-ec and Ex-pz protection, meeting the requirements of national and international standards as well as tested and approved by certifying bodies with worldwide recognition.

### Vertical synchronous motors

WEG also offers vertical synchronous motors able to withstand high loads of axial thrust, which can be manufactured with oil-lubricated rolling bearings or sleeve bearings. The synchronous motors with vertical construction are designed and manufactured to meet the requirements of applications such as pumps, crushers, mixers and others.



## Applications



### Fixed speed

The application of synchronous motors with fixed speed is justified by the low operational costs, since they present high efficiency and can be used as synchronous condenser for power factor correction.

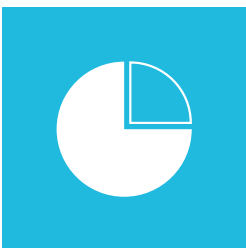

### Variable speed

The application of synchronous motors with variable speed is justified in applications with high torque at low speed and wide range of speed adjustment. Due to the higher efficiency, smaller size and greater power capacity, they can replace direct-current motors in high-performance applications.



### Flexible and customized design

WEG synchronous motors can be manufactured with or without brushes, depending on the load and environment characteristics. They can be specified with low starting currents, generating lower impact on the electrical system during starting, as well as the reduction of the mechanical stresses on the motor windings.

For the correct design and specification of a synchronous motor, WEG recommends that the customers provide all necessary information about the application.

# Construction features

## Frame

The frame function is supporting and protecting the motor, also housing the lamination core and the stator windings. It can be built considering horizontal or vertical construction and with protection degree in accordance with the environment requirements. The frame is built in welded steel profiles and sheets, forming a solid and robust structure that is the structural base of the machine. This kind of construction provides excellent structural strength to withstand mechanical stresses arising from potential short circuits and vibration, enabling the motor to meet the severest conditions.



## Stator

The stator consists of a core of high-quality silicon steel laminations with slots to fit the stator winding, which operates with alternating current power supply in order to generate the rotating magnetic field.



## Rotor

The rotor can be designed with cylindrical poles, laminated salient poles or solid salient poles, depending on the construction characteristics of the motor and its application. The complete rotor is formed by the structure that composes or supports the poles, the field windings and the starting cage, in case of laminated salient poles and cylindrical poles, which are the active rotating parts of the synchronous motor. The field poles are magnetized through the direct current coming from the exciter rotor or directly by slip rings and brushes. In operation, the poles are aligned magnetically by the air gap, and they spin in synchronism with the stator rotating field. The shaft is made of forged steel and machined according to each specifications. The shaft end is normally cylindrical or flanged.

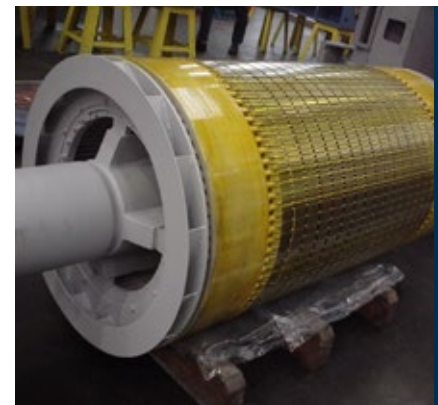



## Construction features

### Bearings

Depending on the application, the synchronous motors can be supplied with rolling bearings or sleeve bearings.

### Rolling bearings

These bearings are normally composed of ball roller bearings or cylindrical roller bearings, depending on the speed and axial and radial loads to which they are subject, and special bearings can be used in some applications. The rolling bearings can be lubricated with oil or grease.

### Sleeve bearings

The sleeve bearings can have natural lubrication (self-lubrication) or forced lubrication (external lubrication).

## Types of excitation

Synchronous motors require a source of direct current in order to supply the necessary power to the field winding (rotor winding), which is usually provided by a rotating brushless exciter or by slip rings and brushes (static exciter).

### Static exciter (with brushes)

Synchronous motors with static exciter are designed with slip rings and brushes that allow the current supply to reach the rotor poles by means of sliding contact. The direct current must come from an AC/DC static controller and converter located outside the motor. Synchronous motors with static exciter are more often used in applications with variable speed with a frequency drive operation or in applications where the system dynamic response must be extremely fast.

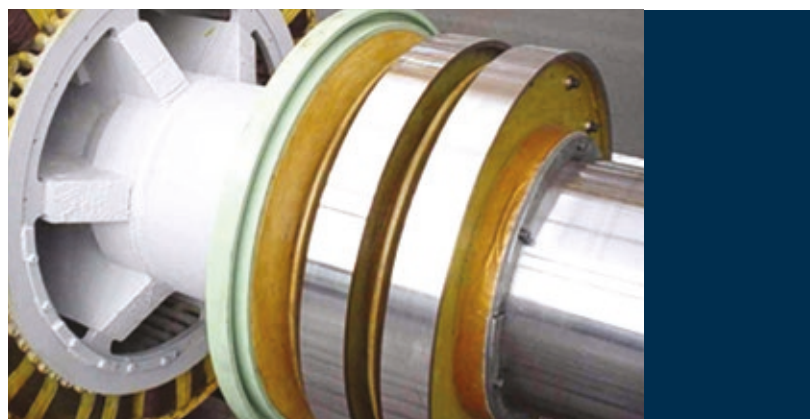



## Types of excitation

### Brushless exciter

Synchronous motors with brushless excitation system present a rotating exciter, normally located in a compartment in the back of the motor. Depending on the motor operation, the exciter is composed by:

- Exciter with direct current supply on the stator
- Exciter with alternating current supply on the stator

The exciter rotor supplies the necessary power to the motor excitation winding through a rotating, three-phase rectifier bridge.

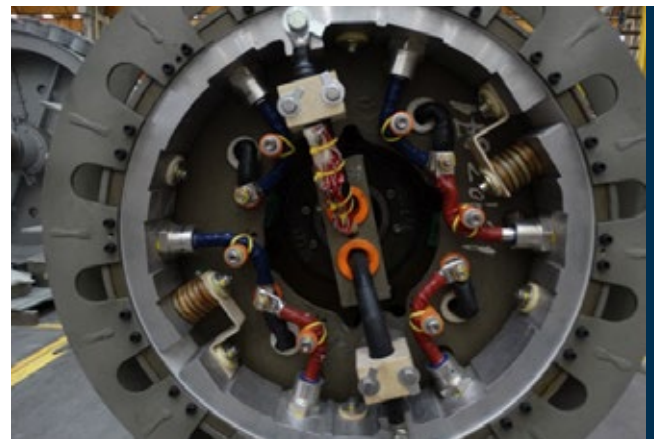

### Exciter rectification circuit for brushless motors

The field application control circuit of the rectification system uses microprocessors to determine the best angle and phase for field application. The Sync-Rite™ system is a high-performance, digitally controlled module developed by WEG Electric Machinery. As an option, a portable Sync-Rite™ testing device can be supplied for easy verification of the circuit electronic components, without the need of disassembling the circuit. In addition to the test device, WEG also offers, as optional items, the display panel and the wireless repeater.



## Types of cooling and degrees of protection

The most widely used types of cooling / protection in synchronous motors are:

- IC01 - self-ventilated, degree of protection IP23 to IP24
- IC611 or IC511 - air-air heat exchanger, degree of protection IP54 to IP65
- IC81W - air-water heat exchanger, degree of protection IP54 to IP65

Besides the types of cooling methods aforementioned, the motors can be supplied with forced ventilation, air inlet and outlet by ducts, and other cooling systems, meeting the requirements of the application and environment where they are installed in the most efficient way.

## Designs of the parts

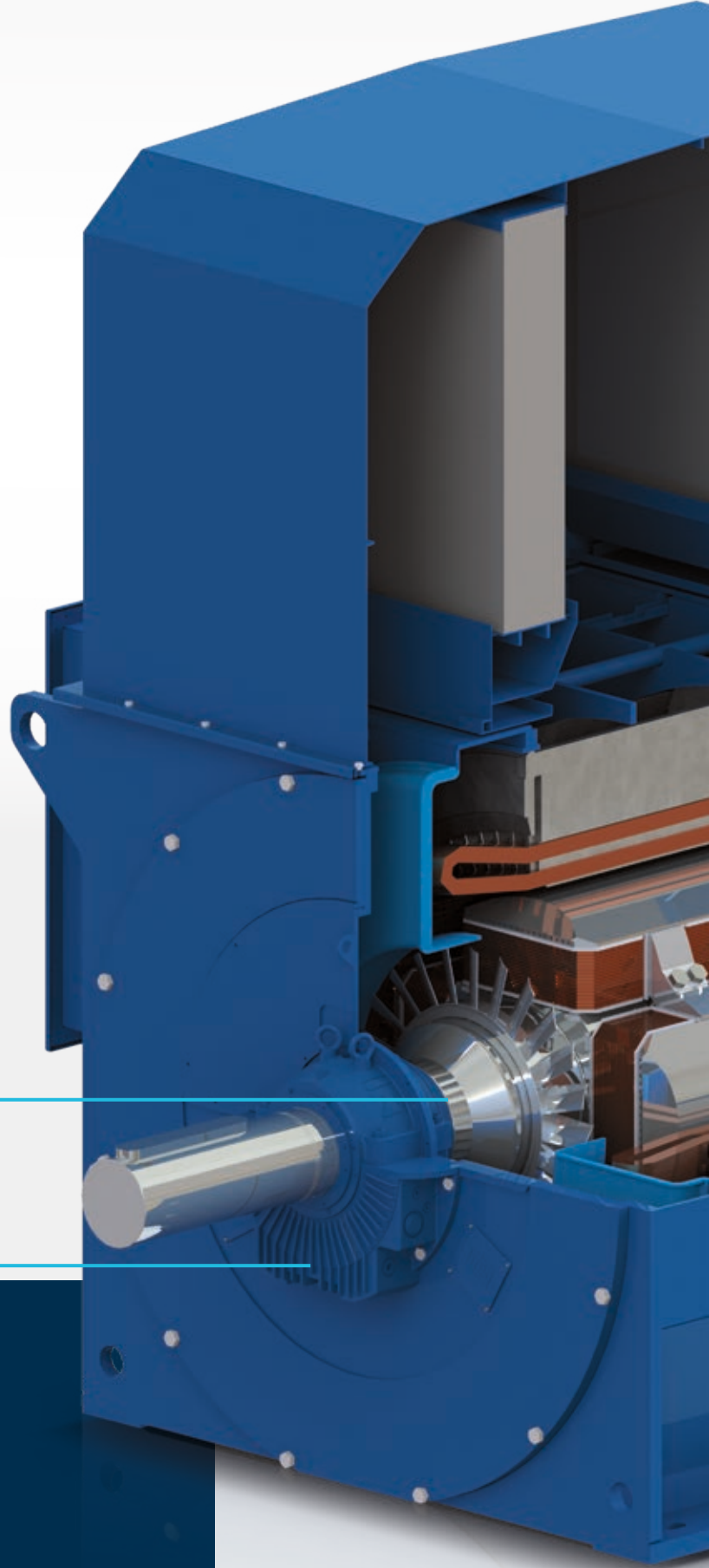

More spacing and greater airflow on the coil heads and bearings

---

Bearings developed with optimized design, ensuring application robustness

---



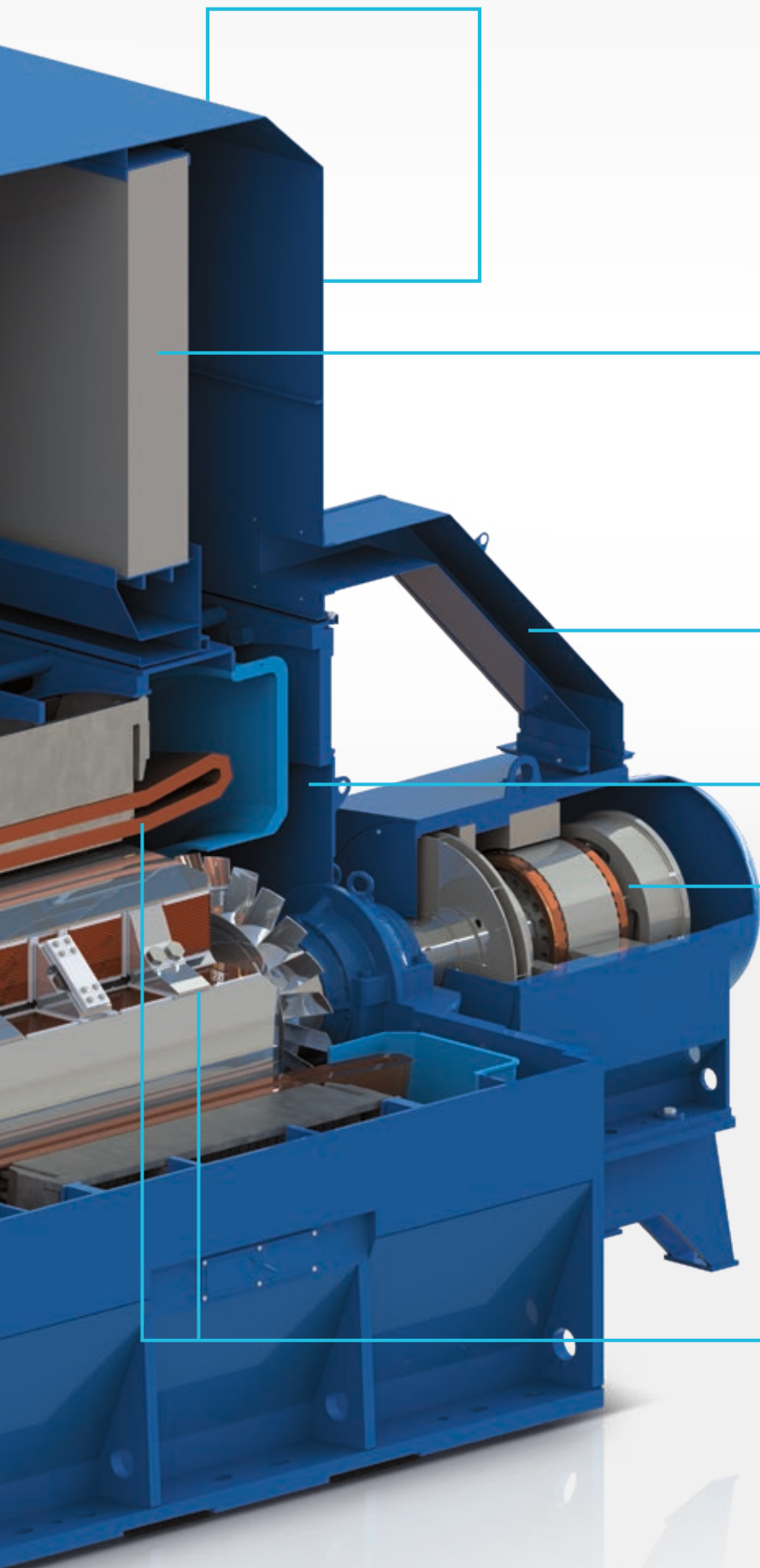

Optimized cooling system, with low levels of vibration and noise

Cooling system with ducts, more efficient and optimized

Integration of the rectifying circuit to the exciter, enhancing the robustness of the excitation system

WEG insulation system guarantees stator and rotor durability, ensuring machine availability for service.

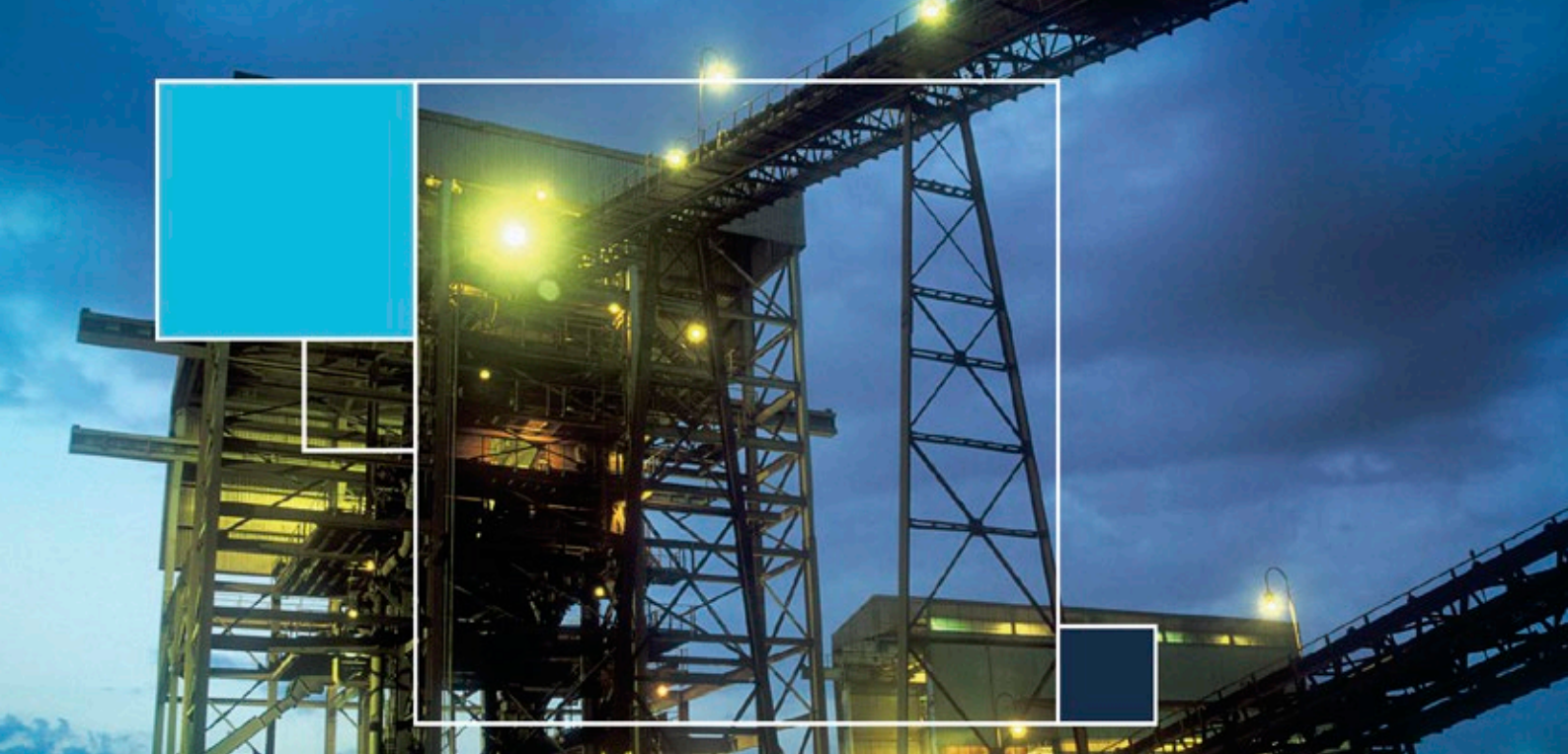

## Accessories

Synchronous motors are supplied with standard accessories required for their proper operation and monitoring. During motor specification, additional accessories can be requested and then included in the motor design and manufacturing processes.

### Standard accessories

- Temperature sensors, type Pt-100, on stator windings
- Temperature sensors, type Pt-100, on the bearings
- Space heaters
- Shaft grounding brush for motors driven by frequency inverters
- Magnetic center indicator (sleeve bearings)

### Special accessories

- Capacitors for surges protection
- Synchronism controller (brushless machines) Sync-Rite Plus, display, wireless repeater
- Lightning arrester for surges protection
- Current transformers (CT) for differential protection
- Vibration sensors for bearing and shaft
- Flow switch for water and/or oil
- Hydraulic unit for bearing lubrication
- High pressure oil injection system to be used during motor starting and stopping (hydrostatic jacking)
- Oil thermometer (bearings)
- Water thermometer (heat exchanger)
- Air thermometer (ventilation)
- Pressurization system (Ex-pz motors)
- Couplers and meters for partial discharges monitoring

# Manufacturing processes

## Winding

The winding process adopted by WEG is especially developed and specified for each motor voltage and application. The coils of the high-voltage motors are manufactured with rectangular, form wound, copper wire completely insulated with porous mica tape. In the winding process, conductor and semiconductor tapes are also used, enveloping the coils and ensuring the suitable characteristics for the required insulating level.

## Insulation system

WEG Micatherm insulation system is based on the Vacuum Pressure Impregnation process (VPI), which has been developed in cooperation with the world's most renowned suppliers of insulating materials.

Using special epoxy resins, this system ensures perfect insulation of the motor winding, in a process totally free from emission of environment harmful gases.

For many years, the VPI process has been showing its efficiency and reliability in electrical rotating machines in many different applications. This insulation system is used in motors with pre-formed coils, for both low and high voltage up to 13,800 V.

## Balancing

WEG uses equipment that allows performing balancing at up to 3,600 rpm.

Computerized balancing equipment allows the accurate balancing of the rotors. As a result, WEG motors present very low vibration levels. The standard balancing is performed in two planes, but in case necessary, to meet specific standards or customer requirements, a three plane balancing can be performed.



*Calender*



*Laser cutting*



*Plasma cutting*



*Vertical lathe*



*Winding*



*Machining*



*VPI impregnation*



## Tests

WEG motors and generators are tested according to NBR 17094-3 standards, IEC 60034, NEMA MG 1 or API on modern laboratories.

WEG has one of the largest laboratories in Latin America with capacity to carry out electrical tests that enable the validation of machine design and development of products.

Laboratories are trained to test the machines according to the norms, thus attesting, the quality and performance of products as specification.



## Technical assistance

WEG technical team provides full after sale support, from general technical clarifications to complete field services, such as diagnosis, start-up and commissioning, all on a 24h duty service. WEG also provides worldwide network of authorized repair shops.

The technical assistance team is highly qualified and experienced, able to handle many different field situations, and providing remote support using state-of-the-art equipment, ensuring reliability of the results.



## Services

In order to restore medium and large electrical machines, customers can count on WEG service team. The same technology used to manufacture motors and generators is used for inspection and restoration. The services are executed at site (at the customer's premises) or at the factories in Jaraguá do Sul/SC, Sertãozinho/SP and São Bernardo do Campo/SP, which are also homologated to execute services on equipment for application in explosive atmospheres. These factories count on full engineering, industrial processes and quality control support and procedures, performing fast and quality services.

### Services can be performed on WEG products or other brands:

- DC generators and motors
- Three-phase induction motors (squirrel cage or slip ring; medium and high voltage)
- Synchronous motors (with or without brushes; medium and high voltage)
- Synchronous condensers
- Turbogenerators
- Hydrogenerators
- Wind turbines
- Steam turbines
- Hydraulic turbines
- Reducers

**WEG Services:** flexibility, agility and experience to optimize your time and productivity.







The scope of WEG Group solutions is not limited to products and solutions presented in this catalogue.

**To see our portfolio, contact us.**

**For WEG's worldwide operations visit our website**



**[www.weg.net](http://www.weg.net)**



 +55 47 3276.4000

 [energia@weg.net](mailto:energia@weg.net)

 Jaraguá do Sul - SC - Brazil

Cod: 50019091 | Rev: 08 | Date (m/y): 05/2023.

The values shown are subject to change without prior notice.  
The information contained is reference values.