



ATENÇÃO:
 -Desconecte da rede elétrica antes de proceder qualquer trabalho neste equipamento.
 -Somente profissionais qualificados podem efetuar a instalação e manutenção.
 -Obedecer normas nacionais, estaduais, locais e instruções de operação.

WARNING:
 -Installation and maintenance to be performed by authorized personnel only.
 -User is cautioned to observe all recommendations, warnings and cautions relating to safety of personnel and equipment as well as general and local health and safety laws, codes and procedures.

ATENCIÓN:
 - Desconectar de la red eléctrica antes de hacer cualquier trabajo en este equipamiento.
 - Recomendarse instalación por profesional calificado.
 - Respetar normas nacionales y locales.
 - Producto destinado a utilización en instalaciones eléctricas de baja tensión.

WARNUNG:
 - Bevor irgend eine Arbeit am Gerät vorgenommen wird, muss sichergestellt sein, dass die Einheit stromlos und freigeschaltet ist.
 - Sämtliche Arbeiten an der Einheit dürfen daher ausschließlich nur von Fachpersonal vorgenommen werden.
 - Die jeweils geltenden nationalen, örtlichen und anlagenspezifischen Bestimmungen und Erfordernisse sind zu berücksichtigen.



PRW08

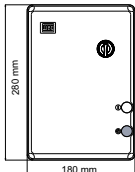
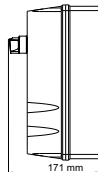
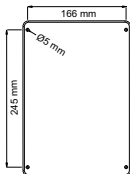

WEG IMPORTERS IN THE EUROPEAN UNION

AUSTRIA - WATT DRIVE ANTRIEBSTECHNIK GMBH - Wöllersdorfer Str. 68, 2753 Markt Piesting, Wiener, Austria; **BELGIUM** - WEG BENELUX S.A. - Rue de l'Industrie 30/D, 1400 Nivelles, Belgium; **FRANCE** - WEG FRANCE SAS - 13 Rue du Morellon, 38297 Saint Quentin Fallavier, France; **GERMANY** - WEG GERMANY GMBH - Geigerstraße 7, 50169 Industriestriebel/Türnich 3, Kerpen, Germany; **ITALY** - WEG ITALIA S.R.L. - Via Viganò de Vizzi, 93/95, 20092 Cinisello Balsamo, Milano, Italy; **NETHERLANDS** - WEG NETHERLANDS - Hanzepoort 23C, 7575 DB Oldenzaal, Netherlands; **PORTUGAL** - WEG EURO-INDUSTRIA ELECTRICA S.A. - R. Eng. Frederico Ulrich 605, 4471-908 Maia, Portugal; **SPAIN** - WEG IBERIA INDUSTRIAL S.L. - C/ Tierra de Barros, 5-7, 28823 Costada, Madrid, Spain; **SCANDINAVIA** - WEG SCANDINAVIA AB - Box 27, 435 21, 43533 Mölntycke, Sweden; **UNITED KINGDOM** - WEG (UK) LTD - Broad Ground Road, Redditch B9889P, Worcestershire, United Kingdom.

Information valid for WEG Group Importers.

PT

Observações:

- 1) Fixação de chave de partida sobre superfície plana.
- 2) Montagem padrão: chave de partida fornecida com todas as ligações internas executadas pela fábrica.
- 3) Reapertar todos os parafusos e observar seção máxima VC dos condutores e torques de conexão.
- 4) Seção máxima e torque de conexão dos condutores conforme especificação do componente.
- 5) Contator: observar a tensão de comando do contator.
- 6) Relé de sobrecarga: ajustar o botão de regulagem para a corrente nominal do motor.
- 7) Especificação técnica conforme norma IEC60947.
- 8) Temperatura ambiente:
 Operação: -5°C...55°C
 Armazenagem: -40°C...70°C
- 9) Numero Máximo de manobras é de 15 manobras/hora (limitado pelo relé de sobrecarga).

EN

Remark:

- 1) Flat surface mounting.
- 2) Standard assembly is with internal wire connections from factory.
- 3) All screws must be tightened respecting the maximum cross section and torque of conductors.
- 4) Maximum cross section and tightened torque according to products specifications.
- 5) Contactor: watch the rated coil voltage of the contactor.
- 6) Overload relay: setting on dial the motor rated current.
- 7) Technical data according to IEC60947.
- 8) Ambient temperature:
 Operating: -5°C...55°C
 Storage: -40°C...70°C
- 9) Maximum operation duty: 15 operate / hour (limited by the overload relay).

ES

Observaciones:

- 1) Fijación del arrancador sobre una superficie plana.
- 2) Montaje estándar: arrancador suministrado con todas las conexiones internas realizadas desde fábrica.
- 3) Verificar el apriete nuevamente de todos los tornillos y mirar sección máxima de los cables y par de apriete.
- 4) Sección máxima y par de apriete de los cables de acuerdo a la especificación del aparato.
- 5) Contactor: Observar la tensión nominal / comando del contactor
- 6) Relé de sobrecarga: ajustar el botón de ajuste para la corriente nominal del motor.
- 7) Especificación técnica de acuerdo a la norma IEC60947.
- 8) Temperatura ambiente:
 Operación: -5°C...55°C
 Almacenaje: -40°C...70°C
- 9) Numero Máximo de maniobras es de 15 maniobras/hora (limitado por el relé de sobrecarga).

DE

Anmerkungen:

- 1) Starter ist für die Montage auf einer ebenen Fläche zu befestigen.
- 2) Standard: Starter wird mit allen internen Verbindungen geliefert.
- 3) Alle Schrauben müssen unter Berücksichtigung des maximalen Anschlussquerschnittes und des Anzugsdrehmoment angezogen werden.
- 4) Maximaler Anschlussquerschnitt und Anzugsdrehmoment entsprechend Spezifikation der Bauteile.
- 5) Schütz: die Steuerspannung des Schützes beachten.
- 7) Überlastrelais: den Einstellknopf auf den Nennstrom des Motors einstellen.
- 7) Technische Daten: gemäß IEC60947.
- 8) Umgebungstemperatur:
 Betrieb: -5°C...55°C
 Lagerung: -40°C...70°C
- 9) Maximale zugelassene Schaltfrequenz: 15 Operationen / Stunde (begrenzt durch das Überlastrelais)

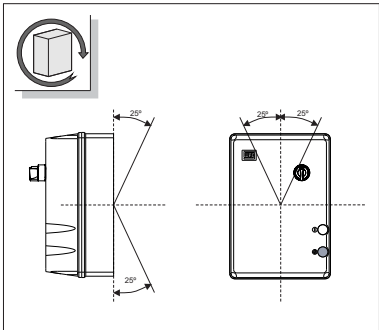

97-98 NO	-REARME MANUAL E TESTE -MANUAL RESET AND TEST	-REARME AUTOMÁTICO E TESTE -AUTOMATIC RESET AND TEST
95-96 NC	-REARME MANUAL E TESTE -MANUELLE RÜCKSTELLUNG UND TEST	-REARME AUTOMÁTICO E TESTE -AUTOMATISCHE RÜCKSTELLUNG UND TEST

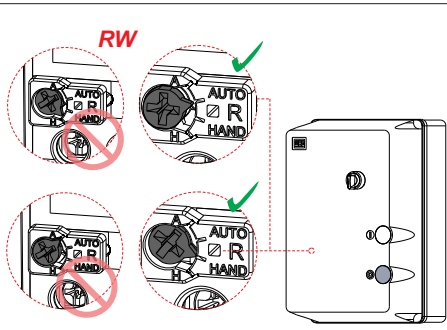



PRW

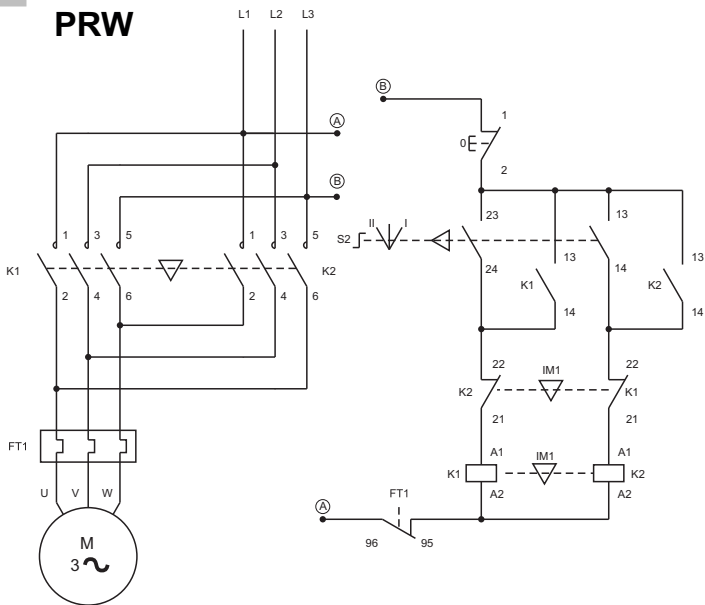

10001332685.02
WEG AUTOMAÇÃO
www.weg.net



(mm²)
(AWG)

GARANTIA / WARRANTY / GARANTÍA/GEWÄHRLEISTUNG:



A WEG oferece garantia limitada contra defeitos de fabricação ou de materiais de seus produtos. Para mais informações acesse nosso site:



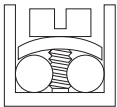
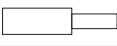
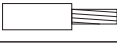

WEG provides a limited warranty for its products against defects in materials and workmanship. For more information access our site:

WEG ofrece garantía limitada contra defectos de fabricación o de materiales de sus productos. Para más informaciones acceda al WEB sitio:

WEG bietet eine beschränkte Gewährleistung für ihre Produkte gegen Herstellungs- und Materialfehler. Für weitere Informationen besuchen Sie bitte unsere Webseite:

www.weg.net/warranty-automation

	CWB9...18		CWB25...38	
	1X	2X	1X	2X
	1...6 18...10	1...4 18...12	1,5...10 16...8	1,5...6 16...10
	1...6 18...10		2,5...10 14...8	
	1...6 18...10		2,5...10 14...8	
 N.m lb.in	1,7 15		2,5 22	

	RW27	
	1X	2X
	1,5...6 16...8	
	1,5...10 16...8	
	2,3 20	