

English



# Quick Installation Guide WEMOB-WALL G2

## Charging Station for Electric Vehicles (VE)

### 1 SAFETY INSTRUCTIONS

All safety procedures described in this quick installation guide and in the installation and operation manual for the WEMOB-WALL G2 electric vehicle charging station must be followed. The recommended procedures aim at protecting the user against death, serious injuries and considerable material damages.

#### 1.1 GENERAL INFORMATION

This quick installation guide contains the basic information required for the installation, configuration and operation of the WEMOB-WALL electric vehicle charging station.

#### 1.2 PRELIMINARY RECOMMENDATIONS

- DANGER!**
- Only qualified personnel, familiar with the charging station and related equipment, must plan or execute the installation, startup, operation and maintenance of this equipment.
  - Such personnel must follow the all the safety instructions contained in this guide, in the installation and operation guide and/or defined by local regulations.
  - Failure to comply with the safety instructions may result in death, serious injury and/or equipment damage.
  - A damaged charging station must be removed from service and repaired. The repair must be carried out by the manufacturer or its representative only. No changes or modifications to the charging station are permitted.
  - Always disconnect the general power supply before touching any electrical part in connection with the electric vehicle charging station.

#### 1.3 PACKAGE CONTENT

- WEMOB-WALL G2 electric vehicle charging station.
- Installation kit: (04 self-tapping screws 4.8 x 38 mm [1.50 in], 04 plastic plugs Ø 8 mm [0.31 in], 01 "L" torx T20 wrench, 04 rubber sealing rings, 01 metal mounting bracket).
- Drilling template.
- Quick installation guide.

#### 1.4 RECEIVING AND STORING

The WEMOB-WALL charging station is supplied packed in a cardboard box. This package contains a label outside describing the main characteristics of the product: model, WEG stock item, serial number, manufacturing date etc.

Check if:

- The identification label matches the purchased model.
- Damages occurred during transportation. If any problem is found, contact the carrier immediately.
- If the WEMOB-WALL charging station is not installed immediately, keep it in the packaging closed and store it in a clean, dry place with temperature between -25 °C and 80 °C (-13 °F and 176 °F).

In order to open the package:

- Place the package on a table.
- Open the package.
- Remove the product.

### 2 OVERVIEW



Figure 2.1: WEMOB-WALL overview

### 3 INSTALLING

The directions and suggestions must be observed to ensure the operation and safety of people and equipment. The procedures are divided into:

- Mechanical installation.
- Electrical installation.

#### 4 MECHANICAL INSTALLATION

The WEMOB-WALL charging station is designed for indoor or outdoor operation, for mounting on garage or parking garage walls, poles, columns and the like. Therefore, it is necessary to ensure some specifications to protect the device in its installation site.

#### 4.1 ENVIRONMENTAL CONDITIONS

The following criteria must be observed when selecting the appropriate installation location:

- To ensure a secure mounting, check the condition of the wall before the installation.
- The mounting surface must be stable and resistant enough to withstand mechanical forces.

- Do not install the charging station on horizontal or inclined surfaces.
- Do not install the charging station in areas at risk of flooding.
- Avoid mounting the station on unstable, moving or uneven surfaces.
- Avoid mounting the equipment below hanging objects or furniture that may fall and damage it.
- If the screws and plugs included in the installation kit are not suitable for the surface, provide fastening hardware specific to the surface type.
- Determine the vehicle parking position to make sure that the station charging cable reaches the electric vehicle charging socket.
- Do not install the charging station near pedestrian and/or vehicle traffic routes, where the charging cable crosses such routes.
- If installed on a column, pole or the like, provide a minimum clearance of 1 m (3.28 ft) around the station to allow users to circulate. It is recommended to provide a barrier to prevent vehicles from colliding with the station.

Environmental conditions for operation:

- Temperature: -25 °C to 50 °C (-13 °F to 122 °F).
- Air relative humidity: 5 % to 95 % non-condensing.
- Maximum altitude: 2000 m (6562 ft) above sea level - rated conditions. For applications at higher altitudes, contact WEG.

To ensure proper operating conditions and a longer service life of the station, the following requirements must be observed:

- Do not install the station in a closed box or near appliances that emit heat.
- Do not install the station in environments without air circulation.
- If possible, protect the charging station from direct exposure to sunlight, rain, excessive humidity, sea air, thunderstorms or other adverse weather conditions.
- Do not spill water or other liquids inside the equipment.
- Avoid exposure to flammable, explosive or corrosive gases, vapors or liquids.
- Do not expose it to excessive vibration.
- Do not expose the charging station to dust, metallic particles or oil mist.
- Avoid exposure to strong water jets, such as a pressure washers, garden hoses etc.
- Periodically clean the outside of the station, the cable and the charging plug.
- Perform the cleaning with the station turned off.
- Never perform the cleaning while the electric vehicle is being charged.
- To perform the cleaning, use a soft, dry cloth only.
- Do not use abrasive cloths, sponges or detergents.
- Do not use solvents or chemicals.
- If the charging station is very dirty, use a cloth slightly moistened with water to remove dust and accumulated dirt.

#### 4.2 POSITIONING

Choose a flat vertical mounting surface, stable and resistant enough to withstand the mechanical forces, with at least 200 mm [7.87 in] clearance on the sides and on top of the charging station for ventilation and storage of the charging cable after use.

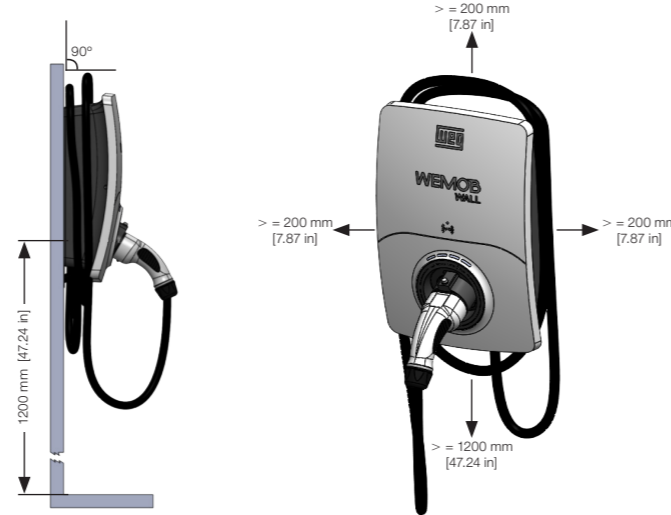

Figure 4.1: Mounting position and spacing of the WEMOB-WALL

- NOTE!**
- We recommend mounting the charging station at a height where the charging socket is 1.2 meter (3.94 ft) above the ground. Please, note that local regulations may limit this height.

#### 4.3 MOUNTING

- ATTENTION!**
- Before installing the charging station, make sure that there are no electrical cables, conduits, water pipes, gas pipes or other obstructions near the drilling points.

The WEMOB-WALL charging station can be mounted in different ways to meet the needs of the installation site. For environments that require greater security, the station has internal fixations (I1, I2, I3 and I4), accessible only by opening the front cover. In other environments, the station can be mounted without opening the front cover, with screws accessible from the outside (E1, E2, E3 and E4) or using a metal bracket (E1, E2, E5 and E6), which guarantees a better fixation.

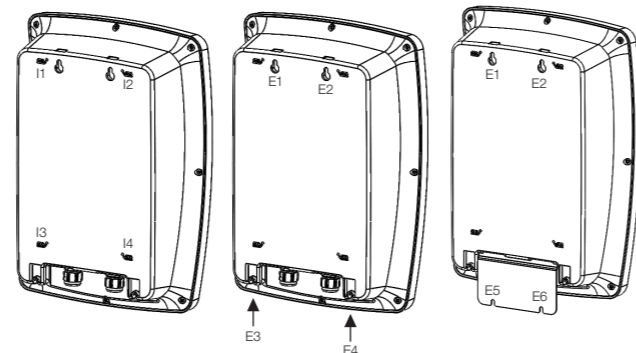
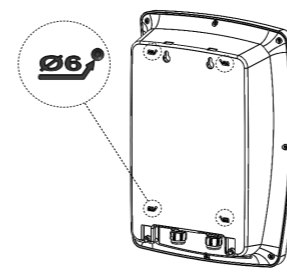

Figure 4.2: WEMOB-WALL mounting methods

#### 4.3.1 Internal Mounting

Mounting from the inside of the station requires opening the front cover. The mounting points I1, I2, I3 and I4 leave the factory closed and to open them it is necessary to use a Ø 6 mm [0.24 in] drill bit. Follow the procedures below:

- Find the four (04) drilling points marked on the rear base of the charging station.



- Using a drill with a Ø 6 mm [0.24 in] drill bit, make the four (04) holes.

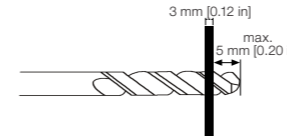

- ATTENTION!**
- Drill in no more than 5 mm [0.20 in], at risk of reaching and damaging internal components. Use a depth gauge.
  - Make sure that the internal plastic wall is perfectly smooth and free of burrs. If any burrs remain, remove them carefully so as not to affect the sealing.

- Position the drilling template on the surface, adjust the installation height and leveling. If necessary, use a spirit level.

- Mark the four (04) holes (I1, I2, I3 and I4) using the drilling template.

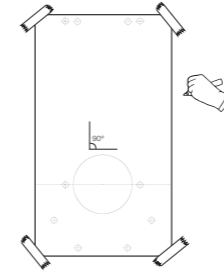

- Remove the drilling template and drill the four (04) holes with a Ø 8 mm [0.31 in] drill bit.

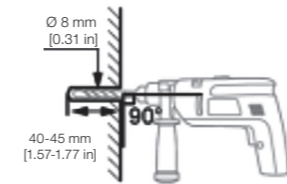

- Insert the four (04) Ø 8 mm [0.31 in] plastic plugs into the holes.

- Using the T20 torx "L" wrench, remove the eight (08) screws on the lower side of the front cover.

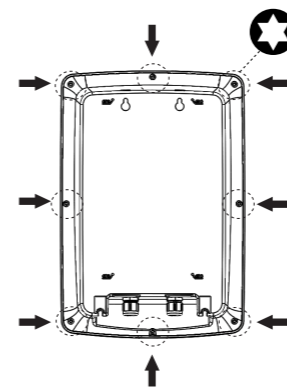

- Remove the front cover by pulling it forward.

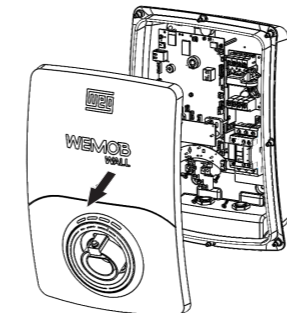

- Put the cover in a safe place, without risk of falling and not subject to impacts.

- Place the charging station close to the wall and align the holes in the rear base with the holes in the wall.

- Insert the sealing rings into the four (04) screws, align the screws with the holes and tighten them.

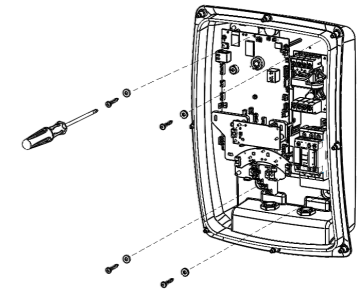

- ATTENTION!**
- Be careful not to damage the circuit boards or charging station components.
  - The electronic boards have electrostatic discharge sensitive components. Do not touch the components or connectors directly.
  - Do not overtighten the screws, as you risk damaging the plastic part.
  - The installation surface must be completely flat so as to avoid deformations.

- After mounting the charging station, reinstall the front cover.

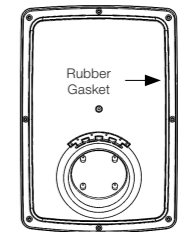

- ATTENTION!**
- Position the front cover rubber gasket correctly.
  - The screws must be tightened in X pattern so that the rubber gasket compresses evenly over the entire length of the cover.
  - If problems are detected in the rubber gasket or in the cable glands, it is recommended to replace the defective part immediately.
  - Any problem with the gaskets may affect the protection rating.

#### 4.3.2 External Mounting

Mounting from the outside of the station does not require opening the front cover. Follow the procedures below:

- Position the drilling template on the surface, adjust the installation height and leveling. If necessary, use a spirit level.

- For mounting without the metal bracket (accessory), mark the four holes (E1, E2, E3 and E4) using the drilling template.

For mounting with the metal bracket, mark points E1, E2, E5 and E6.

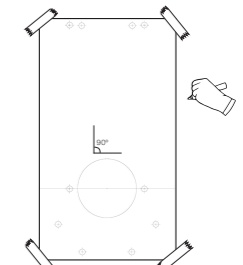

- Remove the drilling template and drill the four (04) holes with a Ø 8 mm [0.31 in] drill bit.

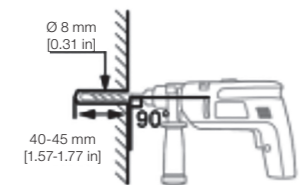

- Insert the four (04) Ø 8 mm [0.31 in] plastic plugs.

- For mounting without the metal bracket (accessory), insert the four (04) screws (E1, E2, E3 and E4) and tighten them leaving a distance from the head of the screw to the wall of 3.5 mm [0.14 in] for the upper screws (E1 and E2) and 10 mm [0.40 in] for the lower screws (E3 and E4).

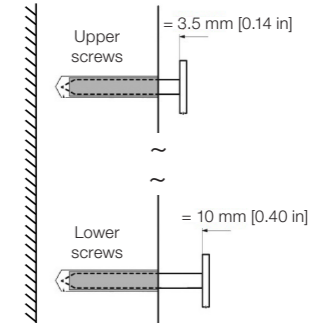

For mounting with the metal bracket, insert the four (04) screws (E1, E2, E5 and E6) and tighten them leaving a distance of 3.5 mm [0.14 in] from the wall for the upper screws (E1 and E2). The lower screws (E5 and E6) can be tightened to the end.

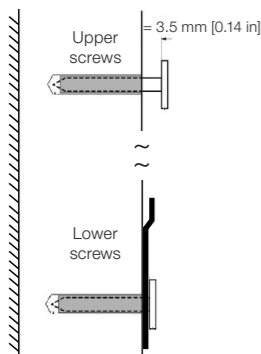

6. Bring the charging station close to the upper fixing points (E1 and E2), align the larger opening with the screw heads and slide it down until it is fully seated on the screws (E3 and E4) or on the metal bracket.

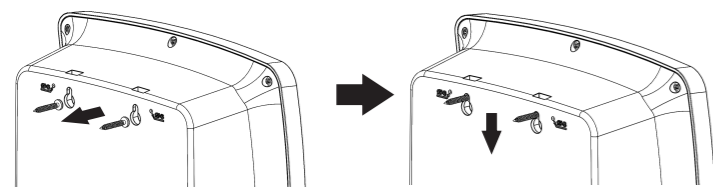

Detail of the upper fitting (screws E1 and E2)

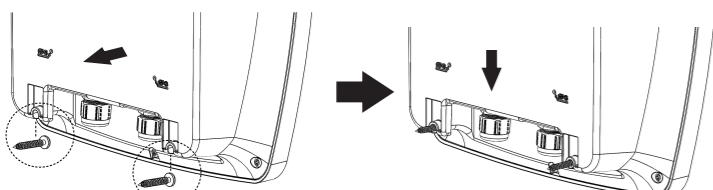

Detail of the lower fitting (screws E3 and E4 -without metal bracket)

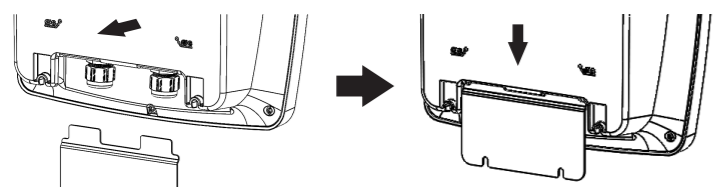

Detail of the lower fitting on the metal bracket

7. Make sure that the station is securely fastened by adjusting the distance from the screw heads to the wall if necessary.

## 5 ELECTRICAL INSTALLATION

**DANGER!**

- Make sure the supply line is disconnected before starting the connections.
- The supply line voltage must be compatible with the WEMOB-WALL voltage range.
- The charging station must be connected to a protective earth (PE). Do not use the neutral for grounding, but a specific conductor. The grounding resistance must be lower than 100 Ω or lower than the maximum value defined in the applicable electrical installation standards, and the voltage between neutral and earth, lower than 10 V.
- The WEMOB-WALL charging station does not have a power switch (On/Off switch). The station can be switched on or off using the circuit breaker or residual current device (RCD or DR), located on the switchboard.

**ATTENTION!**

- The power and charging cables must be routed directly through the PG16 cable gland (closing area for Ø 10 to 14 mm [0.40 to 0.55 in] cable), observing a bending radius of approximately 10 times the diameter of the cable so as to avoid mechanical forces on the station.
- Keep the cable gland thread always tight to prevent the ingress of dust and liquids into the charging station. The recommended torque for tightening the nuts is 5 to 6 Nm.
- When flexible cables are used for the power and ground connections, it is necessary to use suitable terminals at the cable ends.
- All electrical connections must be well tightened so that there is no risk of sparking, excessive heating or voltage drop in the circuits.
- It is recommended to use copper conductors.
- For voltage surge protection, the electronic power supply is protected by varistors. VN (Varistor / Neutral) and VL (Varistor / Phase L1) terminals connected to the neutral (N) and phase (L1) terminals of power terminal block.
- The charging station has a relay output with normally open contacts (NO), whose current must not exceed 1 A. If your electric vehicle requires ventilation during the charging process, the ventilation system must be connected to the station via terminals V1 and V2. The recommended tightening torque of the screws is 0.4 to 0.6 Nm.

### 5.1 SELECTION OF THE RATED CURRENT

**ATTENTION!**

- The WEMOB-WALL charging station is set at the factory to its maximum output current (32 A). If necessary, set the output current value.

The maximum output power of the wall charger is 7.68 kW when the station is powered at 240 V (single-phase or two-phase) with output current of 32 A.

In certain electrical installations, it is not possible to use the maximum power supplied by the charging station due to power line limitations. The WEMOB-WALL charging station allows setting the rated current from 6 to 32 A.

To set the rated current, with the power supply disconnected, follow the instructions below:

1. Open the front cover.
2. Locate the dip switches on the electronic board.
3. Use a small screwdriver or another suitable tool and set the keys according to Table 1.
4. Install the front cover again.

**NOTE!**

- Details of the opening and closing of the front cover are described in item "4.3.1 Internal Mounting".

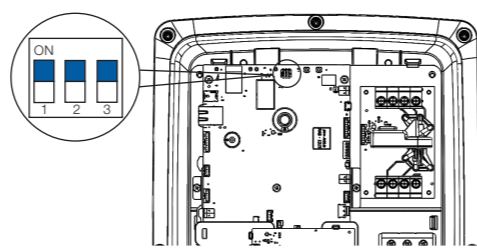

Figure 5.1: Rated current selection switches

Table 5.1: Setting of the rated current

Switch Position			Rated Current
1	2	3	
OFF	OFF	OFF	6 A
OFF	OFF	ON	8 A
OFF	ON	OFF	10 A
OFF	ON	ON	12 A
ON	OFF	OFF	16 A
ON	OFF	ON	20 A
ON	ON	OFF	24 A
ON	ON	ON	32 A

**NOTE!**

- Be careful not to damage the circuit boards or components when setting the rated current.

**DANGER!**

- The selection switches for the rated current must be set with the power supply disconnected. Setting them with the power supply connected, in addition to being dangerous, is not recognized by the system.
- Make sure that the electric vehicle withstands high charging currents. If you are not sure, refer to the manual or manufacturer of the electric vehicle.

### 5.2 POWER CABLE

The WEMOB-WALL charging station is supplied with a 2 m (6.56 ft) electrical cable (3 x 6 mm<sup>2</sup>) already connected to the internal terminals of the station, suitable for the rated current of 32 A.

The charging station can be connected to single-phase or two-phase power supply lines (without neutral), with a rated voltage of 100 to 240 V (50/60 Hz).

- Single-phase (L1 / N).
- Two-phase (L1 / L2).

Table 5.2: Wiring identification

Wire Color	Description
Brown or Black	Phase (L1)
Light blue	Neutral (N)
Green / Yellow	Protective earth (PE)

For the 32 A rated current, it is recommended to use conductors with minimum gauges of: PHASE: 1x6 mm<sup>2</sup>, NEUTRAL: 1x6 mm<sup>2</sup> and GROUND: 1x6 mm<sup>2</sup>.

The appropriate gauge of the power cables depends on the power and distance from the distribution box or switchboard to the charging station. Observe possible correction factors for the current capacity of the cables considering the installation method, temperature, distance and voltage drop. Under certain circumstances, that may lead to an increase in the cable cross section.

### 5.3 PROTECTIVE DEVICES

**ATTENTION!**

- The WEMOB-WALL charging station must be connected to a protective circuit breaker (C curve) and to a residual current device (RCD or DR) with sensitivity of 30 mA (AC) type AC, exclusive to the power supply circuit of the charging station.

When selecting the protective circuit breaker upstream the charging station, check the distribution panel or switchboard to identify the current available at the installation site. Under certain circumstances, as the desired power cannot be installed, the value defined for the rated charging current may have to be reduced.

Determine the rated operating current of the circuit breaker according to the data provided by the manufacturer, the desired charging current set via dip switch, and the gauge and length of the power cable.

Also take into account the derating of the circuit breaker rated current as a function of the ambient temperature in the distribution panel or switchboard.

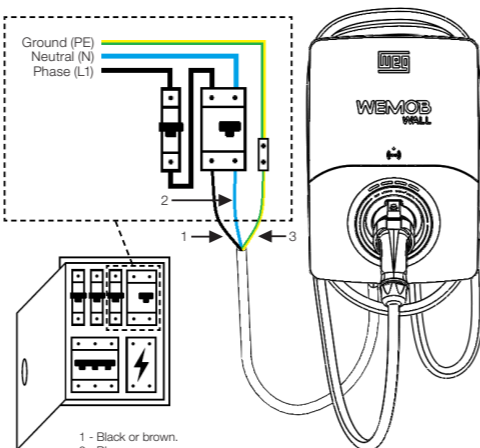

(a) with single-phase circuit breaker and RCD

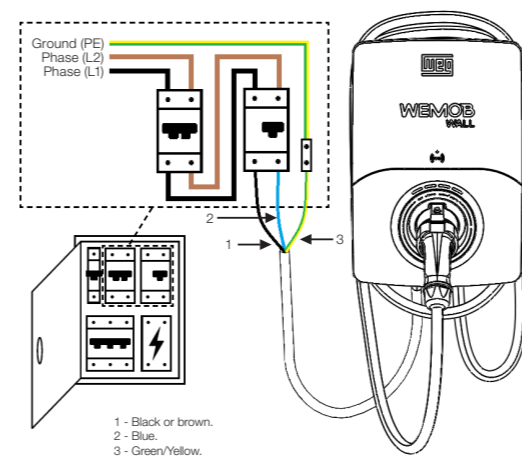

(b) with two-phase circuit breaker and RCD

Figure 5.2: (a) and (b) Examples of single-phase (L1-N-PE) and two-phase (L1-L2-PE) electrical connection

**ATTENTION!**

- In two-phase installations (without neutral), use a two-pole circuit breaker.

**NOTE!**

- For the output current set to 32 A, the use of WEG items is recommended:
  - Single-phase circuit breaker MDWH-C40 40 A curve C (11422717) or
  - Two-phase circuit breaker MDWH-C40-2 40 A curve C (11422719).
  - RCD RDWS-AC-30-40-2-D62 40 A/30 mA type AC (14764114).

### 5.4 CHARGING CABLE

The WEMOB-WALL charging station is supplied with a 5 m (16.40 ft) type 2 charging cable already connected to the internal terminals of the station, suitable for the rated current of 32 A.

**ATTENTION!**

- Make sure that the station charging cable plug (type 2) is compatible with the socket of your electric vehicle.

To release the charging cable from the socket, press the plastic button above the socket (1) and pull the plug backwards (2).

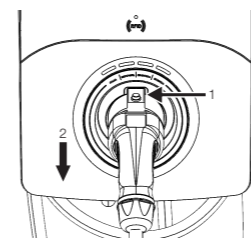

Figure 5.3: Procedure for removing the plug from the socket

**NOTE!**

- When the electric vehicle is completely charged, wind up the cable around the charging station and insert the plug into the socket on the front cover. Do not leave the charging cable on the floor.

Follow the instructions below to avoid damage to the charging cable:

- Unwind the entire charging cable before starting to use it.
- Do not allow the end of the cable (plug) to fall on the floor.
- Never connect the charging cable to an extension cable or adapter.
- Never disconnect the charging cable, either from the station or the electric vehicle, by pulling it.
- Do not pull the charging cable with excessive force.
- Make sure that the charging cable does not touch heat sources, pointed or sharp objects.
- Do not immerse the charging cable in water or other liquids.
- Do not use this product if the charging cable is worn, the insulation is damaged or dirty or shows any other signs of damage.
- A damaged charging cable can cause a short circuit, fire or electric shock.
- Protect the electric vehicle connecting plug against the ingress of liquids or foreign bodies.
- Do not use this product if the charging plug shows signs of corrosion or foreign bodies are present inside the plug.
- Do not make changes or adaptations to the plug.
- The charging cable must not cross pedestrian and/or vehicle traffic routes, where it may be stepped on or subjected to mechanical stresses (bent, stretched or pinched), which may cause pedestrian falls, damage to cables and to the charging station.

## 6 OPERATION

After completing the mechanical and electrical installation, the charging station is ready to go into operation. Turn on the circuit breaker and residual current device (RCD or DR) on the distribution board. When the charging station is energized, the LED will be solid GREEN, indicating that it is available to start charging. If the charging station will not be used for a long time, it is recommended to keep it turned off.

**DANGER!**

- Before operating the charging station, perform a visual inspection for damage. A damaged charging station must be removed from service and repaired.
- Do not allow the charging station to be operated by children or people with reduced mental or sensory abilities.

### 6.1 INDICATION

The LEDs located on the front cover provide visual information about the current operational status of the charging station. It consists of four (04) LEDs, which can light up (steady ON) or blink. In addition, beeps can be emitted to inform the status.

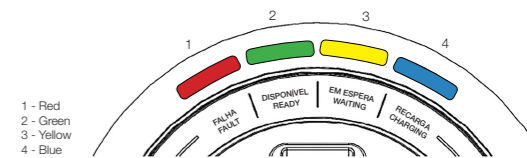

Figure 6.1: Status indication LEDs

Table 6.1: Status indication

LED color	Status	Description
All LEDs blinking	STARTING	Charging station in autotest
All LEDs off	OFF	Charging station without power supply
Solid green	READY	Station ready for use
Solid yellow	WAITING	Electric vehicle connected and in process of recognition
Blinking yellow		Charging ended (complete or not)
Solid blue	CHARGING	Charging in progress
Solid red	FAULT	Station in fault state
Blinking red		Station in error state

## 6.2 CHARGING PROCEDURE

To start charging the electric vehicle, remove the plug from the charging station socket and connect it to the electric vehicle socket. After the plug is connected to the electric vehicle, charging will occur automatically, following the stages:

### Stage 1: Ready

To start charging, check that the station is in the "available" mode (ready for use), with the light indicator in solid GREEN.

### Stage 2: Waiting

The user removes the plug from the station and connects it to the vehicle. After the connection to the vehicle, the charging station indication LED will be solid YELLOW.

### Stage 3: Charging

If the connection is successful, the station will start charging the electric vehicle, and the indication LED will be solid BLUE.

### Stage 4: End

To end the charging process, two methods can be used:

**User intervention:** in this case, the charging must be ended through the vehicle. Each vehicle has its own method for ending the charging. For this method, we recommend reading the vehicle manual for the correct interruption of the process.

**Complete charge:** after the electric vehicle battery is fully charged, the connector will remain locked until the vehicle stops the charging process.

The station LED will be YELLOW, indicating that the charge is complete, and the user intervention is required.

After disconnecting the charging cable, the station will return to the start status, with LED solid GREEN. Available for the next charge.

**DANGER!**

- Do not force the vehicle disconnection by pulling the charging cable. First interrupt the charge through your vehicle, and only after the release remove the plug.
- Some electric vehicles allow the engine to start with the charging cable connected.
- Be sure to disconnect the cable before moving the vehicle.

## 6.3 ERRORS AND FAULTS

If any error, fault or activation of the internal protections is identified, the station LED will be solid or blinking RED and you will hear a beep.

**Fault:** When the LED is solid RED, the station needs intervention; turn the equipment off and on.

**Error:** When the LED is blinking RED, remove the connector from the station and wait for the station to restart.

## 7 DIMENSIONS

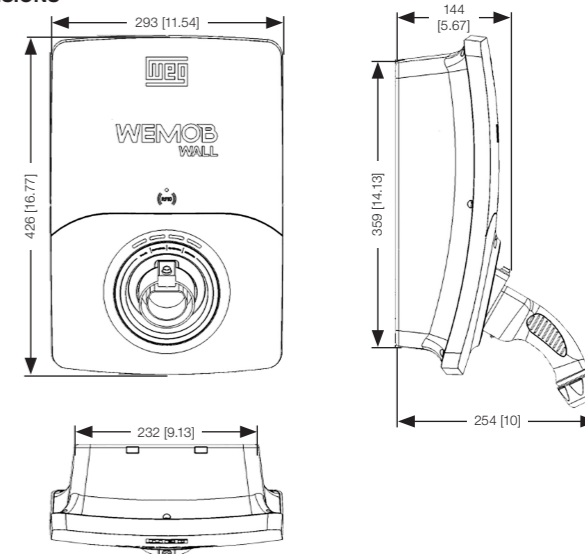

Figure 7.1: Dimensions of the WEMOB-WALL charging station in mm [in]

