

ATENÇÃO:
 -Desconecte da rede elétrica antes de proceder qualquer trabalho neste equipamento.
 -Somente profissionais qualificados podem efetuar a instalação e manutenção.
 -Obedeça normas nacionais, estaduais, locais e instruções de operação.

WARNING:
 -Installation and maintenance to be performed by authorized personnel only.
 -User is cautioned to observe all recommendations, warnings and cautions relating to safety of personnel and equipment as well as general and local health and safety laws, codes and procedures.

ATENCIÓN:
 - Desconectar de la red eléctrica antes de hacer cualquier trabajo en este equipamiento.
 - Recomendase instalación por profesional calificado.
 - Respetar normas nacionales y locales.
 - Producto destinado a utilización en instalaciones eléctricas de baja tensión.

WARNING:
 - Bevor irgend eine Arbeit am Gerät vorgenommen wird, muss sichergestellt sein, dass die Einheit stromlos und freigeschaltet ist.
 - Sämtliche Arbeiten an der Einheit dürfen daher ausschließlich nur von Fachpersonal vorgenommen werden.
 - Die jeweils geltenden nationalen, örtlichen und anlagenspezifischen Bestimmungen und Erfordernisse sind zu berücksichtigen.

DANGER
 RISK OF ELECTRIC SHOCK, BURN OR EXPLOSION



- 1) TURN OFF AND LOCK OUT ALL POWER SUPPLYING THIS EQUIPMENT BEFORE WORKING ON OR INSIDE EQUIPMENT.
- 2) REPLACE ALL DEVICES, DOORS, AND COVERS BEFORE TURNING ON POWER TO THIS EQUIPMENT.
- 3) ALWAYS VERIFY THAT NO VOLTAGE IS PRESENT BEFORE WORKING ON OR INSIDE EQUIPMENT, AND ALWAYS FOLLOW GENERALLY ACCEPTED SAFETY PROCEDURES.

FAILURE TO FOLLOW THESE INSTRUCTIONS WILL RESULT IN DEATH OR SEVERE INJURY.

DANGER
 RISK OF ELECTRIC SHOCK, BURN OR EXPLOSION



- 1) BEFORE MOUNTING THE CIRCUIT BREAKER IN AN ELECTRICAL SYSTEM, MAKE SURE THERE IS NO VOLTAGE PRESENT WHERE WORK IS TO BE PERFORMED.
- 2) METALLIC OR LIVE ELECTRICAL PARTS INSIDE AN ENCLOSURE SHALL BE MOUNTED IN ACCORDANCE TO MINIMUM CLEARANCE. (SEE FIG. 1)
- 3) ALL ENCLOSURE CLOSING HARDWARE MUST BE INSTALLED.

FAILURE TO FOLLOW THESE INSTRUCTIONS WILL RESULT IN DEATH OR SEVERE INJURY.

1. CIRCUIT BREAKER INSTALLATION

Make sure that the equipment is suitable for the installation by comparing nameplate ratings with system requirements. Inspect the equipment for completeness and check for any damage.

Dimensions for electrical and mechanical clearance to respect minimum distance from enclosure or compartment walls.

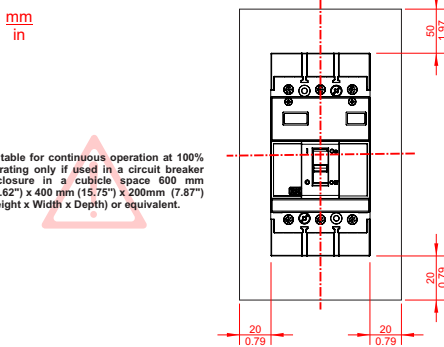

<FIG. 1> Clearance for Circuit Breaker

Suitable for continuous operation at 100% of rating only if used in a circuit breaker enclosure in a cubicle space 600 mm (23.62") x 400 mm (15.75") x 200mm (7.87") (Height x Width x Depth) or equivalent.

Circuit breaker mounting steps:

- 1) For individual surface mounting, drill and tap mounting bolts holes according to the drilling plan shown in Fig. 2. For front mounted applications, refer to Fig. 3 for correct dimensions.
- 2) If circuit breaker includes factory or field-installed internal accessories, make sure that accessory wiring can be reached when the circuit breaker is mounted.
- 3) Position circuit breaker on mounting surface.
- 4) Install circuit breaker using mounting screws provided with the product. Tighten hardware to 13lb.in (1,5N.m)

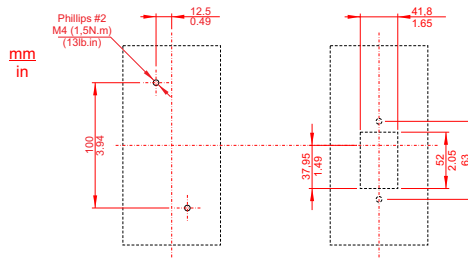

<FIG. 2> Circuit Breaker Drilling Template

<FIG. 3> Circuit Breaker Front view cut out

2. MANUAL OPERATION

Manual Operation of the circuit breaker is controlled by the circuit breaker handle and the TEST button. The circuit breaker has three positions, two of which are shown on the cover with raised lettering to indicate ON and OFF. The third position indicates a TRIP position and is between the ON and OFF positions. (See Fig. 4)

Circuit Breaker Reset

After an automatic, accessory initiated trip, or manual TEST operation, the circuit breaker is reset by moving the circuit breaker handle to the OFF position. (NOTE) In the event of a thermal trip, the circuit breaker cannot be reset until the thermal element in the trip unit cools.

TEST button

The TEST button checks the tripping function and is used to manually trip the operating mechanism. (NOTE) Press TEST button once a year to trip circuit breaker.

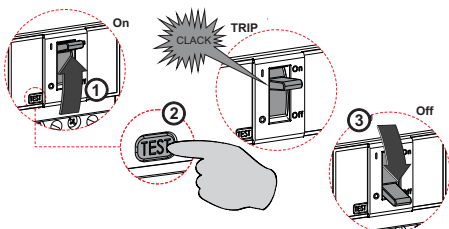

<FIG. 4> Circuit Breaker Manual controls

3. WIRE INSTALLATION

See circuit breaker nameplate label for wire size and torque.

CAUTION

- 1) Each terminal connector or conductor should be connected as shown in the Fig. 5.
- 2) Do not allow conductor strands to interface with threads of wire binding screw.
- 3) Lug for single copper conductor as shown in Fig. 5

FAILURE TO FOLLOW THESE INSTRUCTIONS WILL RESULT IN EQUIPMENT DAMAGE.

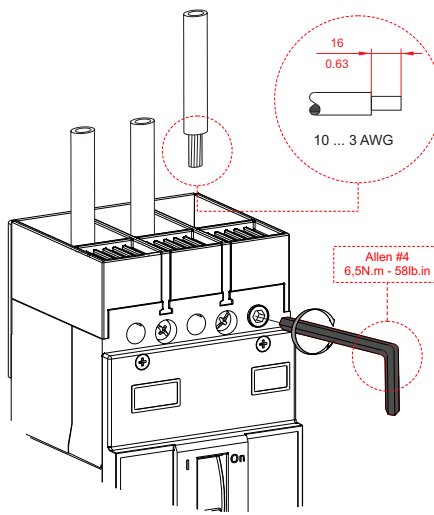

<FIG. 5>

4. CIRCUIT BREAKER REMOVAL

- 1) Turn off all power supplying this equipment before working on or inside equipment.
- 2) Remove circuit breaker in reverse order of installation.

5. ACCESSORIES INSTALLATION (IF REQUIRED)

- 1) Turn off all power supplying this equipment before working on or inside equipment. Handle must be in TRIP position before opening cover.
- 2) Loosen two screws from the auxiliary cover and open it.
- 3) Install field-installable accessories according to instructions supplied with them.
- 4) Close the breaker cover and secure with screws.

6. OTHER SAFETY INSTRUCTIONS

Check area where circuit breaker is installed for any safety hazards including personnel safety and fire hazards. Exposure to certain types of chemicals can cause deterioration of electrical connections.

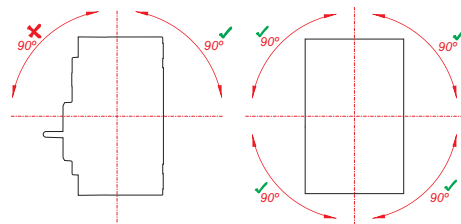

<FIG. 6> Operating Positions

WEG is not liable for the misapplication or incorrect installation of its products. The user is cautioned to observe all recommendations, warnings and cautions relating to the safety of personnel and equipment as well as general and local health and safety laws, codes and procedures.

CAUTION

- 1) No circuit breaker should be reset until the cause of trip is known and the situation rectified.
- 2) Be careful not to damage the equipment during transportation or installation.
- 3) Periodically check terminals and connectors for looseness or signs of overheating.

FAILURE TO FOLLOW THESE INSTRUCTIONS WILL RESULT IN EQUIPMENT DAMAGE.

If any questions arise, contact WEG or refer to the catalog for further information or instructions.

