

W30 Smart Ec / Emerald eZA Single-phase Motor

Installation, Operation and
Maintenance Manual

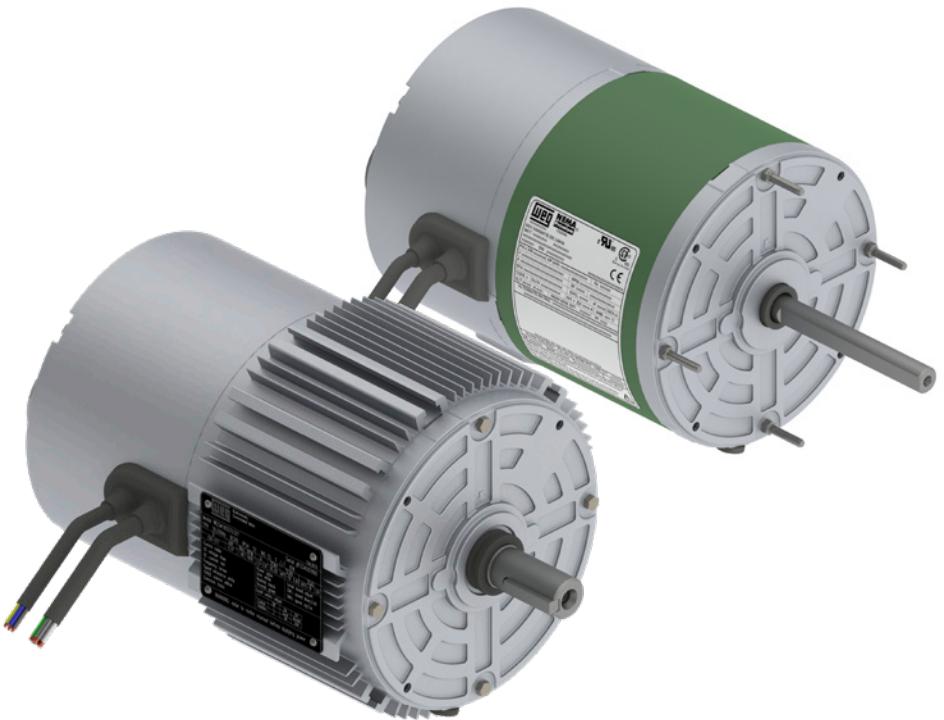

Read carefully this manual before installing and configuring the equipment

The objective of this manual is to provide important information, which must be considered during the shipment, storage, installation, operation and maintenance of WEG motors. Therefore, we advise to make a careful and detailed study of the instructions contained herein before performing any procedures on the motor. The noncompliance with the instructions informed in this manual and others mentioned on the website www.weg.net voids the product warranty and may cause serious personal injuries and material damages. For further information or explanations, check our FAQ at www.weg.net/br/faq.

The instructions presented in this document are valid for W30 Smart Ec / Emerald eZA products.

Index

1. General information	4
1.1. Warnings in this manual	4
2. Safety measures	4
3. Shipment, storage and handling	5
4. Identification labels	5
5. Installation.....	6
5.1. Environmental conditions permitted for the operation.....	6
5.2. Power connections.....	9
5.3. Control connections	10
5.4. EMC requirements for conforming installations	10
6. Quick start.....	11
7. Operation instructions	11
7.1. Selecting the rotation direction.....	11
7.2. How to adjust speed	12
7.3. Control output reference	14
7.4. How to adjust the maximum and minimum speed value	14
7.4.1. Maximum speed.....	14
7.4.2. Minimum speed.....	15
7.5. External speed controller (optional)	15
7.6. Fire mode function (optional).....	16
8. Product protections and fault diagnosis	17
8.1. Information for contacting technical support	19
9. W30 single-phase modbus version (optional)	19
9.1. Control connections	19
9.2. Selecting the rotation direction.....	19
9.3. How to adjust speed	19
9.3.1. Select between local or remote speed adjust.....	19
9.3.2. Modbus speed adjust.....	19
9.4. Led indication.....	20
9.5. Hardware characteristics	20
9.6. Standard characteristics of modbus	20
9.6.1. Modbus command and address.....	20
9.6.2. Special functions	25
9.7. How to exit the time-out state?.....	26
9.8. Digital to analogue – function.....	26
9.9. Fire mode function.....	26
10. Maintenance	26
11. Environmental information	27
12. Additional information.....	27
12.1. Warranty term.....	27
13. Technical specifications	28
13.1. Power supply	28
13.2. Standards and directives	28

1. General information

W30 Smart Ec / Emerald eZA product is an Electronically Commutated Motor composed by a permanent magnet motor and a drive with features customized for commercial ventilation solutions. This Manual contains only the required information that allows qualified and trained personnel to carry out their services. The product images are shown for illustrative purpose only.



ATTENTION!

This line is divided into four different materials for better maintenance understanding, which are:

- Single-phase motor
- Three-phase commercial motor
- Three-phase industrial motors

1.1. Warnings in this manual



DANGER!

The procedures recommended in this warning have the purpose of protecting the user against death, serious injuries and considerable material damage.



ATTENTION!

The procedures recommended in this warning have the purpose of avoiding material damage.



NOTE!

The information mentioned in this warning is important for the proper understanding and good operation of the product.

2. Safety measures

Only trained personnel, with proper qualifications, and familiar with this kind of equipment and associated machinery shall plan and implement the installation, starting, operation and maintenance of this equipment. The personnel shall follow all the safety instructions described in this manual and/or defined by the local regulations.



ATTENTION!

Any service on the internal parts of the motor must be performed by qualified personnel only, since, due to the attraction between metallic parts caused by the magnets, risk of accident is present both in the assembly and disassembly of the motor.



DANGER!

Contains permanent magnets. For pacemaker users, it is recommended to avoid close or prolonged contact with this product, as it may interfere with the proper operation of the device.



DANGER!

Always disconnect the main power supply before touching any electrical device associated with the product. Several components may remain charged with high voltage and/or in movement and may cause injuries to people, even after the AC power supply has been disconnected or turned off. Wait at least 10 minutes to guarantee the fully discharge of capacitors. Always connect the equipment to the ground protection (PE).

3. Shipment, storage and handling

Check the conditions of the motor immediately upon receipt. Where any damage is noticed, this must be reported in writing to the transportation company, and immediately communicated to the insurance company and to WEG. In this case, no installation job can be started before the detected problem has been solved.

Check if the nameplate data matches the invoice data and the environmental conditions in which the motor will be installed. If the motor is not immediately installed, it must be stored in a clean and dry room protected against dust, vibrations, gases and corrosive agents, and with relative humidity not exceeding 60%.

If the motors are stored for more than two years, it is recommended to change the bearings, or to remove, inspect and relubricate them before the motor is started.

If the drive is stocked (out of operation), every year from the manufacturing date indicated on the identification label of the drive (page 5), supply the drive with single-phase voltage between 220 and 277 Vac, 50 or 60 Hz, for at least one hour then de-energize and wait for at least 24 hours before using the drive. If the drive has been in operation for at least 10 years, it is recommended to replace it. For instructions, contact WEG technical support.



DANGER!

- Always handle the motor carefully in order to prevent personal injuries and impacts that could damage the bearings.
- Do not lift and/or carry the product holding by the input cables.
- When available, use only the eyebolts to lift the motor. However these eyebolts are designed for the motor weight only. Thus never use these eyebolts to lift the motor with additional loads coupled to it. For multimounting motors (with removable feet/base), the eyebolts must be positioned according to the motor mounting position so that the lifting angle is vertically aligned (lifting at 0°).
- Additional information regarding the maximum allowable angle-of-inclination is indicated in the general manual available on the website www.weg.net.

4. Identification labels

There is one nameplate with general product information on the W30 Smart Ec / Emerald eZA product that is affixed to the side of the motor frame and one label with basic electronic information that is affixed to the drive (back cover).

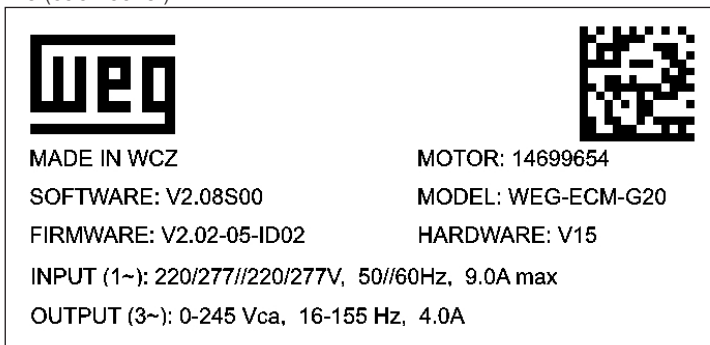
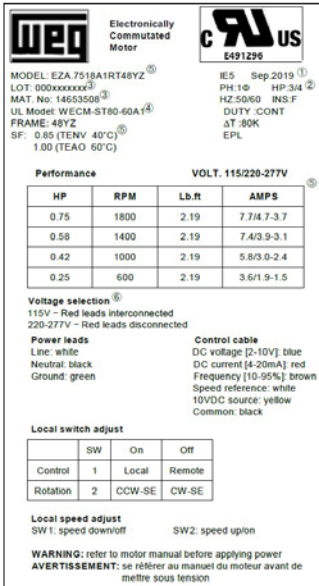

Figure 1 - Drive label



WEG Electronically Commutated Motor

CANUS E491296

MODEL: EZA.751A1RT48V2
 LOT: 000xxxxxx3
 MAT. No: 14653508
 US Model: WEGM-ST60-60A14
 FRAME: 48VZ
 SF: 0.85 (TENV 40°C)
 1.00 (TEAO 60°C)

IE5 Sep 2019
 PH:10 HP:3/4
 HZ:50/60 INS:F
 DUTY:CONT
 ΔT:30K
 EPL

Performance VOLT. 115/220-277V

HP	RPM	Lb.ft	AMPS
0.75	1800	2.19	7.7/4.7-3.7
0.58	1400	2.19	7.4/3.9-3.1
0.42	1000	2.19	5.8/3.0-2.4
0.25	600	2.19	3.6/1.9-1.5

Voltage selection
 115V - Red leads interconnected
 220-277V - Red leads disconnected

Power leads
 Line: white
 Neutral: black
 Ground: green

Control cable
 DC voltage [-10V]: blue
 DC current [4-20mA]: red
 Frequency [10-95%]: brown
 Speed reference: white
 10VDC source: yellow
 Common: black

Local switch adjust

	SW	On	Off
Control	1	Local	Remote
Rotation	2	CCW-SE	CW-SE

Local speed adjust
 SW1: speed down/off SW2: speed up/on

WARNING: refer to motor manual before applying power
AVERTISSEMENT: se référer au manuel du moteur avant de mettre sous tension

Figure 2 - USA/Canada market motor nameplate

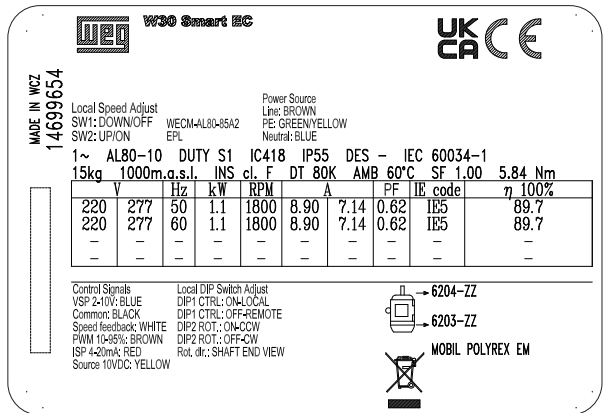

W30 Smart EC UK CA CE

MADE IN WEG 14699654

Local Speed Adjust
 SW1: DOWN/OFF
 SW2: UP/ON

Power Source
 Line: BROWN
 PE: GREEN/YELLOW
 Neutral: BLUE

WEGM-AL80-85A2 EPL

1~ AL80-10 DUTY S1 IC418 IP55 DES - IEC 60034-1
 15kg 1000m.g.s.l. INS cl. F DT 80K AMB 60°C SF 1.00 5.84 Nm

V	Hz	kW	INS	cl.	F	DT	80K	AMB	60°C	SF	1.00	5.84	Nm
220	277	50	1.1	1800	8.90	7.14	0.62	IE5	89.7				
220	277	60	1.1	1800	8.90	7.14	0.62	IE5	89.7				
-	-	-	-	-	-	-	-	-	-	-	-	-	-

Control Signals
 VSP 2-10V: BLUE
 Common: BLACK
 Speed feedback: WHITE
 PWM 10-65%: BROWN
 ISF 4-20mA: RED
 Source 10VDC: YELLOW

Local DIP Switch Adjust
 DP1 CTRL: ON-LOCAL
 DP1 CTRL: OFF-REMOTE
 DP2 ROT.: ON-CCW
 DP2 ROT.: OFF-CW
 Rot. dir.: SHAFT END VIEW

6204-ZZ
 6203-ZZ

MOBIL POLYREX EM

Figure 3 - Motor nameplate

5. Installation



DANGER!

- Make sure the AC power supply is disconnected and protected against accidental energization before starting the installation;
- Check the motor direction of rotation, turning it without load before it is coupled to the load;
- To prevent accidents, ensure that the grounding connection has been performed according to the applicable standards and that the shaft key has been securely fastened before the motor is started;
- Do not lift and/or carry the product holding by the input cables.

5.1. Environmental conditions permitted for the operation

The W30 Smart EC line was designed to operate with IEC418 cooling method - TEAO (Totally Enclosed Air Over) with minimum air velocity as below:

- Frames 80: 5 m/s minimum
- Frame 100: 10 m/s minimum

And under the following conditions

- 20 °C and +40 °C for TENV condition
- 20 °C and +60 °C for TEAO condition
- Air relative humidity: 5 % to 95 % non-condensing.
- Altitudes up to 1000 meters above sea level (nominal conditions)

Consult WEG engineering for different temperatures, ventilation and altitudes.

The WECM have insulation class F and $\Delta t < 80K$ (class B) in nominal conditions of operation.

Motors must be only installed in places compatible with their mounting features and in applications and environments for which they are intended. Those motors with feet must be installed on structures duly planned in order to avoid excessive vibrations and assure perfect alignment. The motor shaft must be properly aligned with the shaft of the driven machine. Incorrect alignment, as well as improper belt tension, will certainly damage the bearings, resulting in excessive vibrations and even causing the shaft to rupture. The admissible shaft radial and axial loads for standard bearings are specified on the table below. Use flexible coupling whenever possible.



Figure 4 - Radial thrust on motor shaft

Maximum permissible thrust - Fr in (kN) 26280 hours					
Direction	Mounting Position	Type	1500rpm	1800rpm	3000rpm
			Force (kN)	Force (kN)	Force (kN)
Axial*	Horizontal	Pushing	0.31	0,29	0.25
		Pulling	0.17	0.16	0.12
	Vertical Shaft Down	Pushing	0.35	0.33	0.27
		Pulling	0.14	0.14	0.10
	Vertical Shaft up	Pushing	0.27	0.27	0.23
		Pulling	0.23	0.20	0.15
Radial**	All	L	0.11	0.11	0.12
		L/2	0.19	0.19	0.16

Table 1 - Allowed loads for Emerald eZA (NEMA 48) motors

Maximum permissible thrust - Fr in (kN) 20000 hours					
Direction	Mounting Position	Type	1500rpm	1800rpm	3000rpm
			Force (kN)	Force (kN)	Force (kN)
Axial*	Horizontal	Pushing	0.90	0.86	0.74
		Pulling	0.50	0.46	0.34
	Vertical Shaft Down	Pushing	0.96	0.91	0.77
		Pulling	0.47	0.44	0.33
	Vertical Shaft up	Pushing	0.87	0.84	0.73
		Pulling	0.56	0.51	0.37
Radial**	All	L	0.66	0.61	0.49
		L/2	0.74	0.69	0.56

Table 2 - Allowed loads for W30 Smart Ec (IEC 80) motors, according maximum speed

Notes:

* Axial max. load (radial zero).

** Radial max load (axial zero).

1 - All belt loads are considered to act in vertically downward direction.

2 - Overhung loads include belt tension and weight of sheave.

3 - Overhung load limits do not include any effect of unbalanced magnetic pull.

Only remove the corrosion protection grease from the shaft end and flange immediately before the motor installation.
Unless specified otherwise in the purchase order, WEG motors are dynamically balanced with “half key” and without load (uncoupled).
The driving elements, such as pulleys, couplings, etc., must be balanced with “half key” before they are mounted on the shaft of the motors.



ATTENTION!

- The air used for cooling the motor must be at ambient temperature, limited to the temperature indicated on the motor nameplate;
- Take the required measures in order to ensure the degree of protection indicated on the motor nameplate:
 - Unused cable inlet holes in the terminal boxes must be properly closed with blanking plugs
 - The cable entries used must be fitted with components, such as, cable glands and conduits;
 - Components supplied loose (for example, terminal boxes mounted separately) must be properly closed and sealed;
 - Fixing elements mounted in the threaded through holes in the motor enclosure (for example, the flange) must be properly sealed.
- For flying leads motors, do not push the overlength of leads into the motor in order to prevent damage to the motor.

Drain hole: Currently, W30 Smart EC / Emerald product are supplied with an automatic drain patented by WEG. Below pictures give details about the mounting configuration.

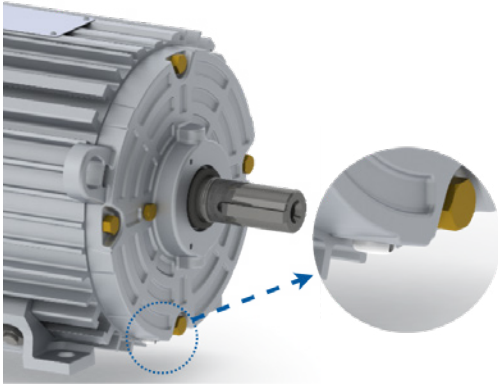

Figure 5 - Drain position

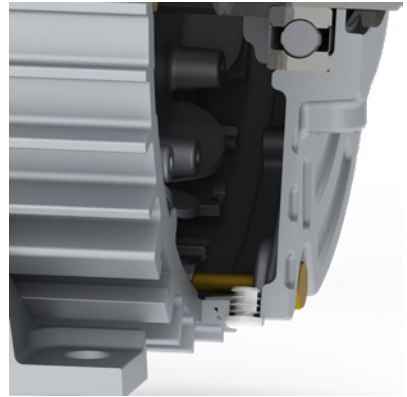

Figure 6 - Drain sectional



ATTENTION!

- The motor must always be positioned so the drain hole is at the lowest position;

Slinger: W30 Smart Ec / Emerald product in vertical shaft up mounting should be fitted with water slinger ring to prevent water ingress inside the motor. Consult WEG about this optional.



ATTENTION!

- Motors installed outdoors or in the vertical position require the use of additional shelter to protect them from water.

Allowed inertias for W30 Smart Ec frames IEC80 single phase, according to output power and speed:

Power (kW)	1500rpm (kgm ²)	1800rpm (kgm ²)	3000rpm (kgm ²)
0.12	0.27	0.27	0.05
0.18	0.27	0.27	0.05
0.25	0.27	0.27	0.05
0.37	0.27	0.27	0.05
0.55	0.27	0.27	0.05
0.75	0.40	0.40	0.27
1.10	0.65	0.65	0.27
1.50	0.65	0.65	0.27

Table 3 - Inertias allowed for single phase line

5.2. Power connections



DANGER!

Connect the motor properly to the power supply by means of safe and permanent contacts, always considering the data informed on the nameplate, such as rated voltage, wiring diagram, etc.

For power cables, switching and protection devices dimensioning, consider the rated motor current, the service factor, and the cable length, among others. For motors without terminal block, insulate the motor terminal cables by using insulating materials that are compatible with the insulation class informed on the nameplate. The minimum insulation distance between the non-insulated live parts themselves and between live parts and the grounding must meet the applicable standards and regulations for each country.

- Input voltage selection (if available):
 - Gauge of the cables: 16 AWG
 - Interconnect the jumper leads to an 115V input voltage;
 - Keep the jumper leads disconnected to 208V or higher input voltage (according nameplate indication);
- Make the line, neutral and ground connections according nameplate indication;

WEG declares that the W30 Smart Ec / Emerald eZA motor line is intended to be used as a part of an end-product and thus is not an independently used machine. All cables of this product need to be internally installed into the enclosure of the final product.



DANGER!

- Make sure the jumper terminals in power cable are insulated to avoid electrical shock.
- SHOCK RISK! Do not touch the jumper terminals after the product is fed.
- Always connect the equipment to the ground protection (PE).



ATTENTION!

- The power supply that feeds the inverter shall have a solid grounded neutral.

5.3. Control connections

- Make the control connections according nameplate indication.



ATTENTION!

Make sure that all unused conductors in control cable are insulated to avoid product damage.

5.4. EMC requirements for conforming installations

The standard W30 Smart Ec /Emerald eZA mounting solution (Drive attached to the motor) comply with the IEC 61800-3 / FCC requirements with the corresponding categories as per the Table 4.

Power	Conducted	Radiated
≤0,55kW	Class C2	Class C2
0,75kW - 1,1kW	Class C2	Class C2

Table 4 - W30 Smart Ec - EMC category compliance for drive attached to the motor, according to IEC 61800-3

For optional decentralized mounting the following characteristics are required to comply with different values of the standard:

Decentralized motor with external Filter (motor cable length≤3meters)			
Power	Conducted	Radiated	Notes
≤0.55kW	C2	C2	(1)Filter is FT121-10, (2)control cable is shielded type, (3)power supply cable between inverter and filter is shielded type, (4)motor cable is shielded type (5) EMC cable gland 4pcs
0.75 - 1.1kW	C2	C2	(1)Filter is FT121-20, (2)control cable is shielded type, (3)power supply cable between inverter and filter is shielded type. (4)motor cable is shielded type (5) EMC cable gland 4pcs

Table 5 - W30 Smart Ec - EMC category compliance for drive attached to the motor, according to IEC 61800-3

For any other condition different than here described please consult WEG for specifying a solution that better comply with your installation requirements.

Only Equipment intended to be use in First environment that have a total rated power lower or equal than 1kW are required to use an external passive filter (PFC) in order to comply with the IEC 61000-3-2 and comply with the C2 requirement for Low-frequency disturbance voltage as indicated in the IEC 61800-3 requirements for the electromagnetic compatibility (EMC).



NOTE!

The end user takes personal responsibility for the EMC compliance of the whole installation.

6. Quick start



ATTENTION!

This quick start only applies to versions without MODBUS. For versions with MODBUS, please refer to chapter 9.3.1.

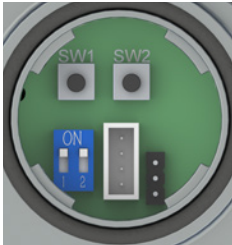

- Connect the power cables to the power supply.
- Isolate the control cables as they have no function in local mode.
- Set DIP switch 1 to the ON position.
- Select the direction of rotation using DIP switch 2 (ON for clockwise and OFF for counterclockwise).
- Select the speed using the tack buttons: keep the SW2 pressed to accelerate and the SW1 to decelerate.

Figure 7 - Product standard control switches

7. Operation instructions



DANGER!

During operation, do not touch the non-insulated energized parts and never touch or stay too close to rotating parts.

The rated performance values and the operating conditions are specified on the motor nameplate. The voltage and frequency variations of the power supply should never exceed the limits established in the applicable standards. Occasional different behavior during the normal operation (actuation of thermal protections, noise level, vibration level, temperature and current increase) must always be assessed by qualified personnel. In case of doubt, turn off the motor immediately and contact the nearest WEG service center.

7.1. Selecting the rotation direction

For more information on local control, please see chapter 7.2.

On the standard communication version of the W30 Smart Ec:

- Remove the plastic lid from the back side of the drive cover;
- Use the DIP switch number 2 to select the rotation direction between counter-clockwise (CCW: switch in ON position) or clockwise (CW), looking from the motor drive end (shaft);
- Reinstall the plastic lid to the back side of the drive cover after the adjust;



NOTE!

If the rotation direction is changed while the product is running, the motor will decelerate, reverse the direction and accelerate to the same speed that was running before.



ATTENTION!

After remove and reinstall, make sure that the plastic lid from the back side of the drive cover is securely closed to guarantee the protection degree.

7.2. How to adjust speed

On the standard communication version of the W30 Smart Ec, the product speed can be changed by local adjust (buttons) or remote adjust (control cable).

* For the MODBUS version, please refer to Item 9.3 for information on speed adjustment.

- To select between local or remote speed adjust:
 - Remove the plastic lid from the back side of the drive cover;
 - Use the DIP switch number 1 to select between local (switch in ON position) or remote adjust;
 - Reinstall the plastic lid to the back side of the drive cover after the speed adjust.



ATTENTION!

After remove and reinstall, make sure that the plastic lid from the back side of the drive cover is securely closed to guarantee the protection degree.

If the rotation direction is changed while the product is running, the motor will decelerate, reverse the direction and accelerate to the same speed that was running before.

- Local speed adjust:

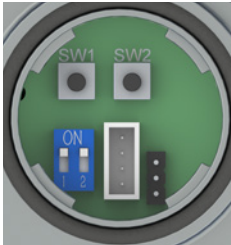

Figure 8 - Product standard control switches

- Remove the plastic lid from the back side of the drive cover;
- Use the two tact buttons located in the opening on the back cover to change speed;
- Keep pressing button SW1 to decelerate or button SW2 to accelerate the motor;
- The motor will turn off when the speed reaches a value lower than the minimum speed of the range;
- Pressing the button <1s, the rotation increase / decrease rate is 100 RPM/s
- Pressing the button >1s, the rotation increase / decrease rate is 300 RPM/s
- The product will not go to speeds higher than the value adjusted to be the maximum speed by WEG EC Motor Speed Controller or Modbus communication; or, case not used, the nominal Nameplate Speed;
- Reinstall the plastic lid to the back side of the drive cover after the adjust.



NOTE!

- The standard maximum speed value is preset at WEG to be the highest value of the speed range but, can be changed by the user (see item 7.4).
- The product has speed memory when operating in local speed adjustment. The last speed adjusted will be kept in memory when the input power supply is removed. The motor will accelerate to the memorized speed when the input power supply is reconnected.
- The local controls inside the opening on the back cover are totally insulated. There is no risk of shock when touch any internal part of this opening, even when the solution is running.



ATTENTION!

After remove and reinstall, make sure that the plastic lid from the back side of the drive cover is securely closed to guarantee the protection degree.

- Remote speed adjust:
 - The speed can be adjusted by the input signals available in the control cable:
 - DC voltage: 2 to 10V DC [tolerance: +10%];
 - DC current: 4 to 20mA DC [tolerance: +10%];
 - Frequency duty-cycle / PWM: 10 to 95%
 - Voltage: 10 to 24Vpk [tolerance: -5%/+10%];
 - Frequency: 80Hz [tolerance: -2,5%/+2,5%];
 - The product will turn off if imposed signals lower than 2V DC, 4mA DC or 10%.
 - The speed can be adjusted using the external speed controller (see item 7.5).
 - Control input reference:

* For the MODBUS version, please follow the cable colors indicated on the motor nameplate or refer to Item 9.1.

Signal type	Condition	Resulting speed value	Conductors	
			1	2
DC voltage ^a	Lower than 2V DC	Zero (motor is off)	Blue	Black
	From 2 to 10V DC	$((Max^b - Min^c)/8) \times (IS^d - 2) + Min$		
DC current	Lower than 4mA DC	Zero (motor is off)	Red	
	From 4 to 20mA DC	$((Max^b - Min^c)/16) \times (IS^d - 4) + Min$		
Frequency	Lower than 10%	Zero (motor is off)	Brown	
	From 10 to 95%	$((Max^b - Min^c)/85) \times (IS^d - 10) + Min$		

Table 6 - Control input reference

- Notes:
- * The DC voltage signal can be applied by an external power supply or using the built-in 10VDC source and an additional potentiometer (5kΩ to 10kΩ); as shown in the image below
 - * Maximum speed adjusted (see item 7.4);
 - * Solution minimum speed (table 9);
 - * Input signal (V DC, mA DC, %) supplied to the respective remote input as shown in the image below.

Control cable electrical connections diagram:

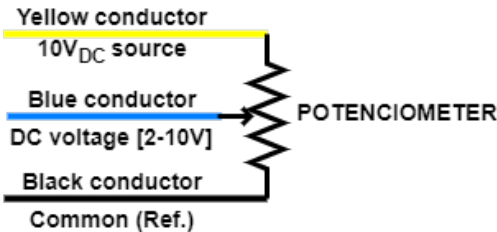

Figure 9 - DC voltage input (using built-in power supply)

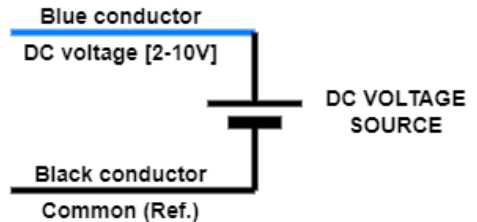

Figure 10 - DC voltage input (using external power supply)

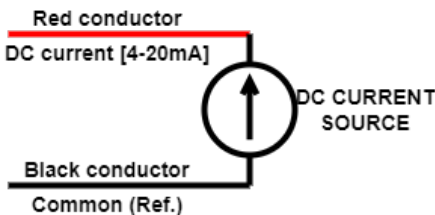

Figure 11 - DC current input

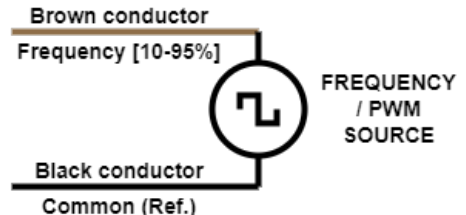

Figure 12 - Frequency input

Recommendation for maximum conductors' length to avoid signal drop for each connection type.

Signal Type	Conductors			Maximum Length (m)	Cable specification
DC voltage (built-in power supply)	Yellow	Blue	Black	10 m	24 AWG
DC voltage (external power supply)	Blue		Blue	10 m	24 AWG
DC current	Red		Blue	300 m	24 AWG
Frequency	Brown		Blue	10 m	24 AWG
Modbus (optional)	Yellow	Red	Black	10 m	24 AWG

Table 7 - Maximum conductors' length recommended for signal wires



ATTENTION!

- The built-in power supply has an output limit of 25mW or 2,5mA;
- The product can be permanently damaged if imposed signals out of the specification;
- Make sure that all unused conductors in control cable are insulated to avoid product malfunction or damage.
- The connection between the Yellow cable (10VDC power source) and the red cable (DC current) will damage permanently the DC current speed control.

7.3. Control output reference

The W30 Smart Ec includes a speed reference. This signal is on at the white control cable. Whenever the white control cable is measured against the ground, a train of pulses with maximum peak value of 4,8V can be measured. The frequency of this train of pulses is proportional to the speed of the motor as explained on the table 8.

Control output reference:

Signal Type	Signal frequency value	Motor Rotation Speed	Conductors	
			1	2
Frequency (speed reference)	0 Hz (Continuous 4.8V signal)	Zero	white	black
	Frequency > 0 Hz	Frequency / 0.6015		

Table 8 - Control output reference

7.4. How to adjust the maximum and minimum speed value

7.4.1. Maximum speed

On the W30 Smart Ec standard communication version, there are two ways to change the maximum speed value for the remote speed adjust signals:

- Using the product local tact buttons (only up to the maximum speed set by WEG EC Motor Speed Controller)
 - Select local speed reference in the DIP switch number 1 (switch in ON position - see item 7.2);
 - Using the tact buttons, adjust the speed to the value desired to be the maximum;
 - Select remote speed reference in the DIP switch number 1;
- Using the optional WEG EC motor external speed controller (up to the nameplate speed).

NOTE!



- The standard manufacturing preset value for the maximum speed is the rated speed informed in the product nameplate;
- Consult WEG about different standard maximum speed values.

7.4.2. Minimum speed

The minimum speed of the W30 Smart Ec motor line is fixed and cannot be change with the use of a standard software. The minimum speed of the line follows the logic of the table below:

Rated speed	≤400rpm	>400rpm and ≤1800rpm	>1800rpm
Minimum speed	70rpm	200rpm	500rpm

Table 9 - Minimum speed according to motor rated speed

Consult WEG about different factory minimum speed values.

7.5. External speed controller (optional)

The target speed and the maximum speed adjust can be done using the external WEG EC Motor speed controller.

Connect the control cables at the WEG EC Motor speed controller borne. Below picture gives the connection sequence.



Figure 13 - WEG EC Motor speed controller

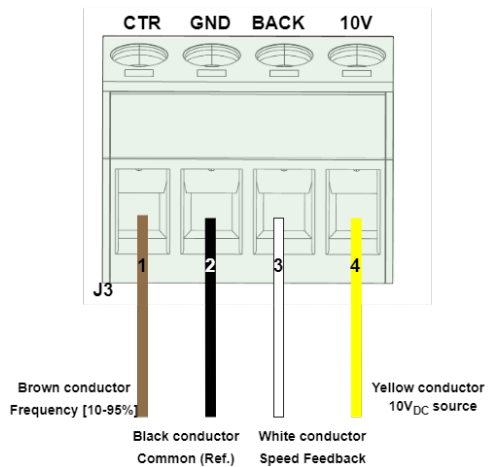

Figure 14 - Controller sequence connection

- Feed the EC motor following the instructions of the item 5.2;
- Target speed speed adjust
 - Connect the conductors from the control cable to the external speed controller according to Figure 14;
 - Rotate CTR in clockwise direction (CW) to increase target speed;
 - Rotate CTR in counter-clockwise direction (CCW) to reduce the target speed;
 - During the adjust, the running speed can be verified in the display;

Maximum speed adjust

- Remove the plastic lid from the back side of the drive cover;
- Connect the external controller to the EC motor using the cable supplied with the external controller and the connector inside the EC motor back opening;
- Rotate MAX in clockwise direction (CW) to increase the maximum speed;
- Rotate MAX in counter-clockwise direction (CCW) to reduce the maximum speed;
- During the adjust, the maximum speed can be verified in the display, during 5s;
- While the max. speed is displayed on the screen, push the button "Enter" to set the maximum speed;

- Disconnect the cable from the EC motor back opening connector;
- Reinstall the plastic lid to the back side of drive cover after the adjust;
- If the maximum speed set is lower than the running speed, the motor will decelerate until reaching the new maximum speed set.



ATTENTION!

After remove and reinstall, make sure that the plastic lid from the back side of the drive cover is securely closed to guarantee the protection degree.

7.6. Fire mode function (optional)



DANGER!

- Notice that the W30 Smart Ec / Emerald eZA is just one of the components of the ventilation system, and it is configurable for different functions, including the “Fire Mode” function;
- Thus, the full operation of the “Fire Mode” function depends on the accuracy of the project and on the joint performance of the components of the system;
- Ventilation systems that work on life safety applications must be certified or approved by the Fire Department and/or other public authority, according to local regulations;
- The non-interruption of the operation of the W30 Smart Ec / Emerald eZA, when configured for operation in the “Fire Mode” function, is critical and must be taken into account in the preparation of safety plans in the environments in which they are installed, since damages may occur to the W30 Smart Ec / Emerald eZA itself and to other components of the ventilation system, to the environment in which it is installed and to people with risk of death;
- The operation in the “Fire Mode” function may, under certain circumstances, result in fire, since the protection devices will be disabled;
- Only personnel from engineering and safety must consider the configuration of the equipment for the “Fire Mode” function;
- WEG strongly recommends to follow the cares and procedures above before using the W30 Smart Ec / Emerald eZA in the “Fire Mode” function, and it will not be liable to the final user or third parties for any losses or damages direct or indirectly incurred due to the programming and operation of the W30 Smart Ec / Emerald eZA in “Fire Mode” regime, considering the critical and special use of this function.



W30 Smart Ec are not 'smoke extraction' motors (as defined in EN 12101-3) and may not under any circumstances be installed inside the high temperature airstream.



NOTE!

When the user activates the “Fire Mode” function, he/she acknowledges that the protection functions of the W30 Smart Ec / Emerald eZA are disabled, which may result in damages to the W30 Smart Ec / Emerald eZA itself, to the components connected to it, to the environment in which it is installed and to people present in such environment; therefore, the user takes full responsibility for the risks arising from such operating condition. Operation with the “Fire Mode” function programmed voids the warranty of the product. The operation in this condition is internally registered by the W30 Smart Ec / Emerald eZA and must be validated by a duly qualified professional of engineering and occupational safety, since such procedure significantly increases the operating risk.

The "Fire Mode" function is intended to make the W30 Smart Ec / Emerald eZA continue work under adverse conditions, inhibiting most faults generated by the electronic in order to protect itself or protect the motor. The "Fire Mode" is selected by applying 10VDC to the frequency input during 5 seconds. The built-in 10VDC source can be used. When selected, the motor will speed up to the maximum speed set and will disable all motor software protections. The only possible way to turn off the "Fire Mode" operation function is to de-energize the complete solution and energize it back again.

8. Product protections and fault diagnosis

W30 Smart Ec / Emerald eZA products have many incorporated electronic protections:

- Input under voltage protection;
- Locked rotor protection;
- Overload protection;
- Over temperature protection.

The motor will reduce its rotation speed to protect the drive from overheating and will automatically recover when normal operation is established. The motor will stop due to IPM temperature in two scenarios: when the IPM critical temperature is reached, or when the rotation speed is lower than 300 RPM.

- Output overcurrent / short-circuit protection;

W30 Smart Ec / Emerald eZA products have a LED in the opening on the back side that indicate the solution status and to help in the fault diagnosis:

The LED #1 will stay ON while the motor is running (speed bigger than zero);

- The LED #1 and LED #2 will stay OFF while the motor is stopped (speed equals to zero);
- The LED #1 will blink in case of any fault, according Table10.
- The LED #2 will blink (1 kHz) while the motor is running (speed bigger than zero)



DANGER!

- The LED in OFF condition doesn't mean that there is no power supply to the drive;
- Make sure that the input power supply is disconnected before do any maintenance in the product.
- If the Fire Mode function is active, the failures will be detected, but ignored by W30 Smart Ec / Emerald eZA, i.e., will not block the IGBTs. If the motor was spinning, will continue spinning. For more information see item 7.6.

The LED will blink in case of any fault. The below table indicates the blinking behavior according the fault type:

Blinking periods	Fault description	ON time	Off time	Wait interval time (off)	Probable Causes	Solution	Fault Recovery	Modbus code Error *3
2 (Fast flash)	Under voltage	0.1	0.1	-	-Voltage supply lower than nameplate limitation. -Input power cable Connection problem. - Hardware problem (Contact WEG).	-Check the power supply voltage. -Check the input power cable connection.	Recovers automatically after power supply recovers.	0x01
3	Overload / over current	0.25	0.25	2	Load used over the motor maximum value; - Higher Ambient temperature than limitation;	-Check the real load application (Measure current from drive to motor*2). -Measure the ambient conditions (temperature and air over the motor).	Recovers automatically after conditions are back to specification.	0x03
5	IPM Temperature limitation				- High Ambient temperature or lower cooling conditions than the minimum (see user manual).	Wait temperature recovery - Consult WEG.	Recovers automatically after temperature gets lower than the limitation.	0x04
6	Overvoltage				-Voltage supply higher than specified in the nameplate.	-waiting power supplier recovered.	Recovers automatically after power supply recovers.	0x02
9	Internal communication timeout	0.25	0.25	2	-Communication fault between the user interface MCU and Motor control MCU.	Reset the power supply. - Consult WEG if this problem persists.	Recovers automatically.	0x06
10	Watchdog timeout				-Electronic noise. -Software failure.	Reset the power supply. - Consult WEG if this problem persists.	- Reset the power supply.	N/A
11	Locked rotor				-Rotor blocked by mechanical problem; - Load overload.	-Check the motor / application status. -Power on again.	- Reset the power supply.	0x05
12	Voltage Transient				- DC Bus voltage changed more than 100V within 250ms.	- Check Input power cable connection.	- Reset the power supply.	0x07
14	Modbus communication time-out*3				-Modbus communication lost between master and slave (WECM).	-Check the MODBUS communication cable status.	- Reset the power supply.	N/A

Table 10 - The blinking behavior according to fault type

*1 Valid for all Software / Firmware versions of W30 Smart Ec / Emerald eZA single-phase line products.

*2 Only to be performed by a professional technical service authorized by WEG

*3 Only valid for MODBUS communication versions at address 0x0050.

The missing blinking periods (no.1 / no.4, no.7, no.8, no.13) are free values with no set functionality from the factory.

8.1. Information for contacting technical support

For technical support and servicing, it is important to have the following information in hands:

- Motor model, Batch number, and manufacturing date available in the motor nameplate (refer to item 4);
- Installed software version available in the drive label (refer to item 4).

9. W30 single-phase modbus version (optional)

All information within this chapter refer exclusively to the WECM / Emerald eZA single-phase products which include the MODBUS communication drive version. Valid from the software version V1.03; examples listed below are used for software version V1.09, 1.10 and 1.11

9.1. Control connections

In the WECM / Emerald eZA single-phase product with MODBUS communication, the control cables will follow the functionalities described in table a below:

Singal	Cable Color	Function
485R	Yellow	Connect with A signal (TX+) of RS485 BUS
485T	Red	Connect with B signal (TX-) of RS485 BUS
DC voltage [2-10V]	Blue	Connect with external adjustable voltage, control motor speed in VSP mode
PWM	Brown	Connect with external PWM signal, control motor speed in PWM mode
10VDC	White	10 DC voltage power supply
GND	Black	GND terminal

Table 11 - Control Connections

9.2. Selecting the rotation direction

The direction of rotation can be adjust using the MODBUS communication or the DIP switch 2. The MODBUS communication will have a higher hierarchy that the DIP switch. Please refer to MODBUS communication section of this manual.

9.3. How to adjust speed

The product speed can be changed by local adjust (buttons), remote adjust (control cable) and MODBUS communication.

9.3.1. Select between local or remote speed adjust

Using MODBUS communication and write register address W(05) 0x00DC (Local / Remote) as it is explain on the MODBUS communication section of this manual

The default value for this register is REMOTE so the standard product can be use as remote control.

9.3.2. Modbus speed adjust

- Set to 1 the modbus registers for Modbus control enable (W(05) 0x00DD), Modbus control run/stop (W(06) 0x01C4) and Local/Remote mode (W(05) 0x00DC).
- Define the application maximum speed in the register W(06) 0x01C2 (max speed)
- Define the motor rotation speed in the register W(06) 0x01C3 (target speed)

9.4. Led indication

The WECM / Emerald eZA Modbus version product has two LEDs on the user operable interface (back of the drive cover): 3LD1 and 3LD3.

The LEDs have the following function:

3LD1 – (Green led)

While in normal operation:

- Indicate Local / Remote control mode:
 - Led ON – Local Mode
 - Led OFF – Remote mode (Default value)

While using MODBUS communication:

- When checking Modbus address, by inputting the command described in the MODBUS version of this manual, the LED flashes the same number of times as the current address count.

3LD3

While in normal operation:

- Motor Run/Stop indication:
 - Led ON – Run
 - Led OFF – Stop

Fault state indication:

- In fault state, the blink behavior will follow the Table 10 of the general product manual.

An additional code will be 14 blinking periods which indicate the “Time-out state” described in 8.6.2

9.5. Hardware characteristics

In order to use the MODBUS, the connection needs to be made on the 485R and 485T cables from the control connections according to Table 11.

In addition, the DIP switch 1 allows the selection of the terminating resistor as per the logic below:

- ON – Terminating resistor Enable
- OFF – Terminating resistor Disable

It is necessary to enable the terminating resistor at both ends of the main bus for each segment of the RS485 network. In the presence of a daisy chain connection, the first and the last WECM products need to have the terminating resistor on ENABLE position.

9.6. Standard characteristics of modbus

The default characteristics for the MODBUS control version are described below:

Baud Rate:	19200 bits/s
Data bits:	8 Bit
Parity:	Even
Stop bits:	1 Bit

Both the baud rate and the parity are configurable using the corresponding register.

9.6.1. Modbus command and address

Function codes:

Read:

- R(01): read Coils;
- R(02): read Discrete Inputs;
- R(03): read Holding Registers;
- R(04): read Input Registers.

Write:

- W(05): write single Coil;
- W(15): write multiple Coils;
- W(06): write single Holding Register;
- W(16): write multiple Holding Registers.

Data definition:

01 Request Frame							
Slaver Address (1 byte)	0x01 (function code)	Register Address (2 bytes)	0x0001 (2 bytes)	CRC (2 bytes)			
01 Answer							
Slaver Address (1 byte)	0x01 (function code)	Register Address (1 bytes)	Data (1 bytes)	CRC (2 bytes)			
02 Request Frame							
Slaver Address (1 byte)	0x02 (function code)	Register Address (2 bytes)	0x0001 (2 bytes)	CRC (2 bytes)			
02 Answer							
Slaver Address	0x02	Register Number	Data	CRC			
03 Read Frame							
Slaver Address (1 byte)	0x03 (function code)	Register Start Address (2 bytes)	Register Numbers N (2 bytes)	CRC (2 bytes)			
03 Answer							
Slaver Address (1 byte)	0x01 (function code)	Register Number N*2 (1 byte)	Request Data 1 (2 bytes) (datas)	Request Data N (2 bytes)	CRC (2 bytes)	
04 Request Frame							
Slaver Address (1 byte)	0x04 (function code)	Register Start Address (2 bytes)	Register Numbers N (2 bytes)	CRC (2 bytes)			
05 Write Frame							
Slaver Address (1 byte)	0x05 (function code)	Register Start Address (2 bytes)	Write Content (2 bytes)	CRC (2 bytes)			
05 Answer							
Slaver Address (1 byte)	0x05 (function code)	Register Start Address (2 byte)	Write Content (2 byte)	CRC (2 bytes)			
06 Write Frame							
Slaver Address (1 byte)	0x06 (function code)	Register Address (2 bytes)	Write content (2 bytes)	CRC (2 bytes)			
06 Answer							
Slaver Address (1 byte)	0x06 (function code)	Register Address (2 bytes)	Write content (2 bytes)	CRC (2 bytes)			
16 Write Frame							
Slaver Address (1 byte)	0x10 (function code)	Register start Address (2 bytes)	Registers number N (2 bytes)	Registers byte number N*2 (1 byte)	Write content 1 (2 bytes)	Write content N (2 bytes)	CRC (2 bytes)
16 Answer							
Slaver Address (1 byte)	0x010 (function code)	Register start Address (2 bytes)	Register number N (2 bytes)	CRC (2 bytes)			

Address table:

For software version V1.03 and V1.04S02 use table 12. For software version V1.09, 1.10 and 1.11 use table 13. All other examples in this manual are based on the function codes and register address from software version V1.09. Contact WEG if there is any questions regarding software version.

Read	Function	Read (R) or Write (W) Address	Values (D = Default value)
R(01)	Local/Remote Mode	R: 0000	0: Local; 1: Remote.
R(01)	Relay State	R: 0001	0: open 1: close
R(01)	Read Fire mode flag	R: 0002	0: out fire mode; 1: in fire mode
R(01)	Read AC lose flag	R: 0003	0: False 1: True
R(01)	Read direction	R: 0004	0: CW 1: CCW
R(01)	Read Run/Stop	R: 0005	0: Stop; 1: Run.
R(03)	Read motor number	R: 0000	
R(03)	Read Firmware version (Motor)	R: 0001	
R(03)	Read Software version (Communication)	R: 0002	
R(03)	FCT Max Speed	R: 0003	
R(03)	Current Max Speed	R: 0004	
R(03)	Read motor Target speed	R: 0005	
R(03)	Read motor actual speed	R: 0006	
R(03)	Read LINK DC motor voltage	R: 0007	Volts
R(03)	Read LINK DC motor current	R: 0008	10mA (value in this register times 10mA)
R(03)	Read Fault code	R: 000B	
R(03)	Read Fault code	R: 000C	Address: 000C Refer to Table 4– Fault Code Table
R(03)	Read multi register	0x01 + 0x03 +start address+ register number N + CRC	0x01 + 0x03 +start address+ register number N + CRC
W(06)	Modbus control enable	W: 0000	0: disable (D) 1: enable
W(06)	Run/Stop	W: 0001	0: Stop (D) 1: Run
W(06)	Write Max speed	W: 0002	
W(06)	Write Target speed	W: 0003	0 – Max. Speed 0 (D)
W(06)	Write Target direction	W: 0004	0: CW (D) 1: CCW
W(06)	Turn on/off Fire mode	W: 0005	0: Fire mode disable (D) 1: Fire mode active
W(06)	Write Local/remote	W: 0006	0: Local Mode 1: Remote Mode (D)
W(06)	Write Modbus address	W: 0007	Valid range 0-99 85 (D) Note: Max. number of motors connected should not be bigger than 32
W(16)	Write Multi register	Write Register address:0000	
W(06)	Slaver Baud-Rate	W: 0008	See Table 2– Baud Rate Setting

Read	Function	Read (R) or Write (W) Address	Values (D = Default value)
W(06)	Slaver Parity and stop bit	W: 0009	See Table 3– Parity and Stop bit setting
W(06)	Enable serial parameters	W: 000A	0: No action 1: Enable
W(06)	Communication time-out period (Seconds)	W: 000B	Value in seconds (Default:0 - disabled)
W(06)	Communication time-out period (ms)	W: 000C	Value in milliseconds (Default:0 – Disabled)
W(06)	Safety Speed	W: 000D	Default 200 RPM
W(06)	Deceleration rate*1	W: 000E	0-300 RPM/S 0 (D)
W(06)	Acceleration rate*1	W: 000F	0-500 RPM/S 0 (D)
W(06)	Blanking time*1	W: 0010	0-65534 Seconds 0 (D)

Table 12 - Register map for version V1.03 and V1.04S02.

Function Code		Register Address		Description	Values (D): Default value
Read	Write	Hex	Multicom V3		
R (04)	-	0x0002	0002	Read motor current speed	
R (04)	-	0x0003	0003	Read LINK DC motor current	
R (04)	-	0x0004	0004	Read LINK DC bus voltage	
R (04)	-	0x0005	0005	Read frequency (motor)	
R (04)	-	0x0007	0007	Read output voltage (motor)	Calculation based on approximations from ventilation application -15% tolerance. For other applications is required to consult WEG.
R (04)	-	0x0008	0008	Read analog input (VSP)	mV resolution
R (04)	-	0x0009	0009	Read analog input (ISP)	mA resolution
R (04)	-	0x000A	0010	Read analog input (PWM)	1% resolution
R (04)	-	0x0017	0023	Read software version of Mid-controller	
R (04)	-	0x0018	0024	Read firmware version of motor driver MCU	
R (04)	-	0x0019	0025	Read factory value of Max Speed	
R (04)	-	0x001A	0026	Read motor number	
R (04)	-	0x001E	0030	Read critical temperature (IPM)	°C
R (04)	-	0x0032	0050	Read Error code	
R (01)	W (05)	0x00DC	0220	Local/Remote mode	0: Local mode 1: Remote mode (D)
R (01)	W (05)	0x00DD	0221	Modbus control enable	0: Disable modbus control enable (D) 1: Enable modbus control enable
R (01)	W (05)	0x00DF	0223	Target direction	0: CW 1: CCW
R (03)	W (06)	0x0134	0308	Modbus address	Valid range 0-99 85 (D)
R (03)	W (06)	0x0136	0310	Serial Configuration: Baud Rate	See table 7- Baud rate setting
R (03)	W (06)	0x0137	0311	Serial Configuration: Parity & Stop	See table 8- Parity and Stop bit setting
R (02)	-	0x015E	0350	Alarm relay state	0: No Fault 1: Fault identified
R (02)	-	0x015F	0351	Motor status: Running or stopped	0: Motor stopped (D) 1: Motor running

Function Code		Register Address		Description	Values (D): Default value
Read	Write	Hex	Multicom V3		
R (03)	W (06)	0x0190	0400	Safety Speed	
R (01)	W (05)	0x0191	0401	Fire Mode	0: out fire mode 1: in fire mode
R (01)	W (05)	0x0192	0402	New Serial Configure Enable	0: No action 1: Enable configure
R (03)	W (06)	0x0193	0403	Communication time-out period (Seconds)	Value in seconds (Default:0 - disabled)
R (03)	W (06)	0x0194	0404	Communication time-out period (ms)	Value in milliseconds (Default:0 – Disabled)
R (03)	W (06)	0x01C2	0450	Max speed	
R (03)	W (06)	0x01C3	0451	Target speed	
R (03)	W (06)	0x01C4	0452	Modbus control run/stop	0: Stop(D) 1: Run

Table 13 - Register map for software versions V1.09, 1.10 and 1.11

Baud rate (bits/s)	Correspond Value of Register 0x0008 (D = Default)
2400	2400
4800	4800
9600	9600
19200	19200 (D)
38400	38400
57600	57600

Table 14 - Baud Rate Setting

Parity /Stop bit	Correspond Value of Register 0x0009(D = Default)
No parity, 1 stop bit	0x0000
Even parity, 1 stop bit	0x0001 (D)
Odd parity, 1 stop bit	0x0002
No parity,2 stop bit	0x0003
Even parity, 2 stop bit	0x0004
Odd parity, 2 stop bit	0x0005

Table 15 - Parity and Stop bit setting

Fault Description	Fault Status Code
DCBUS_LOW (low DC bus)	0x0001
DCBUS_CRITICALLY_HIGH (critically high DC bus)	0x0002
GATE_DRIVE_OVER_CURRENT_FAULT (gate drive overcurrent fault)	0x0003
IPMTEMPERATURE_CRITICALLY_HIGH (critically high IPM temperature)	0x0004
LOCKED_ROTOR (locked rotor)	0x0005
COMM_TIMEOUT (communication timeout)	0x0006

Table 16 - Fault Code Table

9.6.2.Special functions

Time-out Period (Communication failure) + Safety Speed

■ When Enabled: The MODBUS inverter (WECM) slave, after the communication is lost with the master for a period of time set at in the time-out set period (Register W(06) 0x0193 and W(06) 0x0194), will send the motor to “Time-out state”

■ Time-out state: When the product enters time-out state (communication loss), the motor will automatically start the sequence for “Safety Speed”. The sequence for Safety speed will differ according to the firmware version the motor if using.

Software version different than V1. 04S02:

The motor will go directly to the Safety speed that can be set using the Register W(06) 0x0190 (Default value 200RPM, minimum speed).

Software version V1. 04S02:

The motor will follow the logic below:

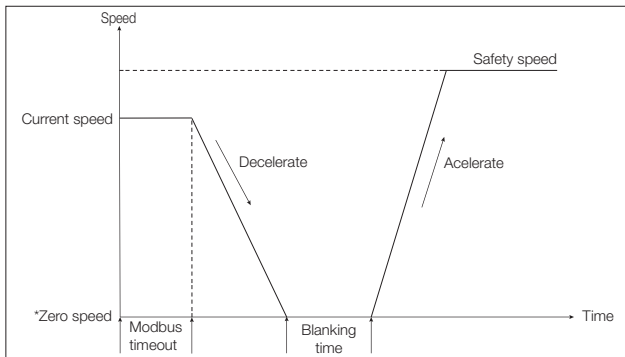

Figure 15 - Time out logic for s04 firmware version

The motor will decelerate to zero and stay in condition (Stop) during a period called the “Blanking time”. After the blanking time is finished, the motor will accelerate (according to the acceleration ratio set on register W(06): 0x00F) to the final Safety speed.

The “**blanking time**” can be set using the register W(06): 0x0010 (Table 2).

The final “**Safety speed**” can be set using the register W(06):000D (Table 2).

Note: Both of this registers will only be considered when one of the registers (W(06):000B or W(06):000C have a value different than “0”, which mean, this function is enable).

While in Time-out state, the 3LD3 led will flash in a sequence of 14 times per interval according to the LED fault table in section 4.3.6 of this manual. The values written into this registers will be kept after the power-off from the power supply.

9.7. How to exit the time-out state?

There are actually four different ways to exit the time-out state as per the list below:

- Power cycle the product (Disconnecting and connecting again to the power supply).
- Disable the MODBUS control (Set the register W(05): 0x00DD to the value “0”).
- Send the “Reset to factory defaults” command using 0x 00 3C 55 AA + CRC (Checksum).
- Setting a new target speed by Modbus whenever the in the “Time-out” state (Writing a new speed through register W(06): 0x01C3).

9.8. Digital to analogue – function

When the product controller has the Modbus Mode (Register W(05)/R(01): 0x00DD value “1”) enabled, the end-user can switch to analogue input control (Through the control connections) using Modbus registers. Software version V1.04S02: To exit the Modbus mode the user can apply 10VDC to the PWM input (either using an external power source or by connecting the WECM 10VDC power source (white cable) into the PWM brown cable) during a period longer than 3 seconds. At this moment, the motor will switch to analogue control and will follow any input values from the control cables.

NOTE: When the Analogue function is activated through the 10VDC method described above, the register W(05)/R(01): 0x00DD will automatically change to the value “0” as the Modbus is “Disabled”.

9.9. Fire mode function

IMPORTANT: When using the product MODBUS communication version, it is possible to activate the “Fire Mode” function will be through the MODBUS corresponding register. Software version V1.04S02: The 10VDC applied to the PWM control connection cable (brown) will have a different functionality as it is described in the 4.3.4. All other functions / warnings and characteristics of the “Fire Mode” Function are still identical to the ones described in the ones described for standard single phase motor.

10. Maintenance



DANGER!

- Before any service is performed, ensure that motor is it at standstill, disconnected from the power supply and protected against accidental energization. Even when the motor is stopped, dangerous voltages may be present in space heater terminals;
- For motors with permanent magnet rotor (W30 Smart Ec and Emerald eZA), the motor assembly and disassembly require the use of proper devices due to the attracting or repelling forces that occur between metallic parts. This work must only be performed by a WEG Authorized service center specifically trained for such an operation. People with pacemakers cannot handle these motors. The permanent magnets can also cause disturbances or damages to other electric equipment and components during maintenance.



ATTENTION!

- Motor disassembly during the warranty period must be performed by a WEG authorized service center only;
- Regularly inspect the operation of the motor, according to its application, and ensure a free air flow. Inspect the seals, the fastening bolts, the bearings, the vibration and noise levels, the drain operation, etc. The lubrication interval is specified on the motor nameplate.

11. Environmental information

For information regarding disposal at end of life cycle refer to the manual "[Disposal and Environmental Information](#)" available in the website www.weg.net or contact WEG.

12. Additional information

For further information about shipment, storage, handling, installation, operation and maintenance of electric motors, access the website www.weg.net.

For special applications and operating conditions refer to the manual 50033244 available in the website or contact WEG.

When contacting WEG, please, have the full description of the motor at hand, as well as the Motor model, Batch Number and manufacturing date, indicated on the motor nameplate.

12.1. Warranty term

WEG Equipamentos Elétricos S/A, Motors Unit ("WEG"), offers warranty against defects in workmanship and materials for its products for a period of 18 months from the invoice date issued by the factory or distributor/dealer, limited to 24 months from the date of manufacture.

The paragraphs above contain the legal warranty periods.

If a warranty period is defined in a different way in the commercial/technical proposal of a particular sale, that will supersede the time limits set out above.

The warranty periods above are independent of the product installation date and the startup.

If any defect or abnormal occurrence is detected during machine operation, the customer must immediately notify WEG in writing about the occurred defect, and make the product available for WEG or its Authorized Service Center for the period required to identify the cause of the defect, check the warranty coverage, and perform the proper repairs.

In order for the warranty to be valid, the customer must be sure to follow the requirements of WEG's technical documents, especially those set out in the product Installation, Operation and Maintenance Manual, as well as the applicable standards and regulations in force in each country.

Defects arising from the inappropriate or negligent use, operation, and/or installation of the equipment, non-execution of regular preventive maintenance, as well as defects resulting from external factors or equipment and components not supplied by WEG, will not be covered by the warranty.

The warranty will not apply if the customer at its own discretion makes repairs and/or modifications to the equipment without prior written consent from WEG.

The warranty will not cover equipment, components, parts and materials whose lifetime is usually shorter than the warranty period. It will not cover defects and/or problems resulting from force majeure or other causes not imputable to WEG, such as, but not limited to: incorrect or incomplete specifications or data supplied by the customer; transportation, storage, handling, installation, operation and maintenance not complying with the provided instructions; accidents; defects in the construction works; use in applications and/or environments for which the machine was not designed; equipment and/or components not included in the scope of WEG supply. The warranty does not include disassembly services at the buyer's premises, product transportation costs and travel, lodging and meal expenses for the technical staff of the Service Centers, when requested by the customer.

The services under warranty will be provided exclusively at WEG authorized Service Centers or at one of its manufacturing plants.

Under no circumstances will the warranty services extend the equipment warranty period.

WEG's Civil Liability is limited to the supplied product; WEG will not be liable for indirect or consequential damages, such as losses of profit and revenue losses and alike which may arise from the contract signed between the parties.

13. Technical specifications

13.1. Power supply

- Rated voltage: according product nameplate;
- Voltage tolerance: -10% to +10%;
- Frequency: 50/60 Hz (48Hz to 62Hz);
- Phase imbalance: $\leq 3\%$ of the rated phase-to-phase input voltage;
- Minimum interval between consecutive power-cycle (ON/OFF) of the W30 Smart Ec input: 5 minutes.
- Maximum 1 connection from power supply cycle per 5 minutes.

13.2. Standards and directives

W30 Smart Ec motors comply with the latest versions of the following standards and regulations:

- EN 60034-1: Rotating electrical machines - Part 1: Rating and performance
- EN 60034-2-1: Rotating electrical machines - Part 2-1: Standard methods for determining losses and efficiency from tests (excluding machines for traction vehicles)
- EN 60034-5: Rotating electrical machines - Part 5: Degrees of protection provided by the integral design of rotating electrical machines (IP code) – Classification
- EN 60034-6: Rotating electrical machines - Part 6: Methods of cooling (IC code)
- EN 60034-7: Rotating electrical machines - Part 7: Classification of types of constructions, mounting arrangements and terminal box position (IM code)
- EN 60034-8: Rotating electrical machines - Part 8: Terminal markings and direction of rotation
- EN 60034-9: Rotating electrical machines - Part 9: Noise limits
- EN 60034-14: Rotating electrical machines - Part 14: Mechanical vibration of certain machines with shaft heights 56 mm and higher - measurement, evaluation and limits of vibration
- IEC TS 60034-30-2: Rotating electrical machines - Part 30-2: Efficiency classes of variable speed AC motors (IE-code)
- IEC 60072-1: Dimensions and Output Series for Rotating Electrical Machines Part 1: Frame Numbers 56 to 400 and Flange Numbers 55 to 1080
- EN 60204-1: Safety of machinery - electrical equipment of machines - Part 1: General requirements
- IEC 61800-3: Adjustable speed electrical power drive systems - Part 3: EMC requirements and specific test methods
- IEC 61000-3-2: Electromagnetic compatibility (EMC) - Part 3-2: Limits - Limits for harmonic current emissions
- IEC 61000-3-3: Electromagnetic compatibility (EMC) - Part 3-3: Limits - Limitation of voltage changes, voltage fluctuations and flicker in public low-voltage supply systems, for equipment with rated current $\leq 16\text{A}$ per phase and not subject to conditional connection
- UL/IEC 61800-5-1:2007: Adjustable speed electrical power drive systems - Part 5-1: Safety requirements - Electrical, thermal and energy
- 2017/2102 (amending 2011/65/EU) - RoHS
- 2014/35/EU - The Low Voltage Directive (LVD)
- 2014/30/EU - Electromagnetic Compatibility (EMC) Directive

EU Declaration of Conformity

Manufacturers:

WEG Equipamentos Elétricos S.A.

Av. Prefeito Waldemar Grubba, 3000
89256-900 - Jaraguá do Sul - SC - Brazil
www.weg.net

WEG Linhares Equipamentos Elétricos S.A.

Rod. BR 101, Km 161,5, s/n.
Distrito Industrial Rio Quartel. Bairro Rio Quartel de Baixo 29915-500
Linhares - ES - Brazil
www.weg.net

WEG MEXICO, S.A. DE C.V.

Carretera Jorobas - Tula Km 3.5, Manzana 5, Lote 1, Fraccionamiento
Parque Industrial Huehuetoca, Municipio de Huehuetoca, C.P. 54680,
CD. de Mexico y Área Metropolitana - Mexico
www.weg.net/mx

WEG (Jiangsu) Electric Equipment CO.,LTD.

No. 88, Huimin West Road, Chengbei Street, Rugao City, Jiangsu
Province - China
www.weg.net/cn

WEG (Nantong) Electric Motor Manufacturing CO., LTD.

No. 128# - Xinkai South Road, Nantong
Economic & Technical Development
Zone, Nantong, Jiangsu Province - China
www.weg.net/cn

ZEST WEG Electric

6 Laneshaw Street, Longlake Extension 4,
Johannesburg, Gauteng, 1619 - South Africa
www.weg.net/za

WEGeuro, S.A.

Rua António Joaquim Campos Monteiro, 510, Santa Cristina do
Couto, 4780-165 - Santo Tirso - Portugal

Single Contact Point in the European Union for compiling the
technical

documentation:
Luís Filipe Oliveira Silva Castro Araújo
Authorised Representative
www.weg.net/pt

WEG TURKEY SANAYI A.S.

Mermerciler OSB Kocaeli, Dilovasi, Köseler, Block 162, Map Section 2

WEG INDUSTRIES (INDIA) PVT.LTD.

No. E20 (North) SIPCOT Industrial Complex - Phase II - Expansion II.
Mornapalli Village Hosur 635109 Tamil Nadu

Changzhou Yatong Jiewei Electromotor Co.,LTD

No.118, Dongdu West Road, Luoyang Town, Wujin, Changzhou,
Jiangsu, China.

Antriebstechnik KATT Hessen GmbH

(Bahnhofstrasse 66, 34576 Hornberg (Efze), Germany
<https://akh-antriebstechnik.de/>

WEG (Chang Zhou) Automation Equipment Co.,Ltd

No. 227, Xincheng Avenue, Jintan District,
Changzhou City, Jiangsu Province, China.
www.weg.net/cn

Declares under sole responsibility that WEG electric motors and components used for following motor lines:

BLDC, W01, W11, W12, W20, W21, W22, W23, W30, W40, W50, W51, W60, W80, WFL, WIN, K1F, K1N, K1O, K1S, K1T, K1W, K2F, K2N, K2U, General Purpose, HGF, Roller Table, Steel Motor, PSC, Pump/Filter, Servomotor, Vertical High Thrust, Water Cooled and WQuattro

when installed, maintained and used in applications for which they were designed, and in compliance with the relevant installation standards and manufacturer's instructions, comply with the provisions of the following relevant European Union harmonization legislation and standards, wherever applicable:

Low Voltage Directive 2014/35/EU*;

EU Ecodesign Directive (EU)2019/1781* as amended by Commission Regulation (EU)2021/341; Directive 2009/125/EC**;

RoHS Directive 2011/65/EU* and its amendments including Directive 2015/863/EU;

Machinery Directive (EU)2023-1230**;

EMC Directive 2014/30/EU (electric motors are considered inherently benign in terms of electromagnetic compatibility).

EN 60034-1:2010 + AC:2010 / EN 60034-2-1:2014 / EN IEC 60034-5:2020 / EN 60034-6:1993/ EN 60034-7:1993 + A1:2001 / EN 60034-8:2007 + A1:2014 / EN 60034-9:2005 + A1:2007 / EN 60034-11:2004/ EN 60034-12:2017/EN IEC 60034-14:2018 / EN 60034-30-1:2014/ EN 60204-1:2018 /EN IEC 60204-11:2019 / CLC IEC/TS 60034-30-2:2021 / EN 61800-5-1: 2007+A1:2017+A11:2021 / EN IEC 61800-3: 2018 / EN IEC 63000:2018 / CLC IEC/TS 60034-25:2024 and IEC 60034-30-3:2024.

* Electric motors with a voltage rating higher than 1000V are not under the scope.

** Electric motors are considered partly completed machinery and are supplied with a "Declaration of Incorporation".

Declaration of Incorporation

The products above cannot be put into service until the machinery into which they have been incorporated has been declared in conformity with the Machinery Directive.

A Technical Documentation for the products above is compiled in accordance with part B of annex VII of Machinery Directive (EU)2023-1230.

We undertake to transmit, in response to a reasoned request by the national authorities, relevant information on the product identified above (partly completed machinery) through WEG authorized representative established in the European Union. The method of transmission shall be electronic or physical method and shall be without prejudice to the intellectual property rights of the manufacturer.

Signed for and on behalf of the manufacturer:

VITOR
MARCON:795
68173900
Assinado de forma
digital por VITOR
MARCON:79568173900
Dados: 2024.12.04
08:44:34 -03'00'

Vitor Marcon
Quality Systems and
Certifications Manager
Jaraguá do Sul
November 1, 2024

EDSON JOSE
KOSHINSKI:0
2103921933
Assinado de forma
digital por EDSON JOSE
KOSHINSKI:02103921933
Dados: 2024.12.04
15:03:41 -03'00'

Edson Jose Koshinski
Engineering Director
Jaraguá do Sul
November 1, 2024



Declaration of Conformity

Manufacturers:

WEG Equipamentos Elétricos S.A.

Av. Prefeito Waldemar Grubba, 3000
89256-900 - Jaraguá do Sul - SC - Brazil
www.weg.net

WEG Linhares Equipamentos Elétricos S.A.

Rod. BR 101, Km 161,5, s/n.
Distrito Industrial Rio Quartel. Bairro Rio Quartel de Baixo
29915-500 - Linhares - ES - Brazil
www.weg.net

WEG MEXICO, S.A. DE C.V.

Carretera Jorobas - Tula Km 3.5, Manzana 5,
Lote 1, Fraccionamiento Parque Industrial Huehuetoca,
Municipio de Huehuetoca, C.P. 54680,
CD. de Mexico y Área Metropolitana - México
www.weg.net/mx

WEG (Jiangsu) Electric Equipment CO.,LTD.

No. 88, Huimin West Road, Chengbei Street, Rugao City, Jiangsu
Province - China
www.weg.net/cn

WEG (Nantong) Electric Motor Manufacturing CO., LTD.

No. 128# - Xinkai South Road, Nantong
Economic & Technical Development
Zone, Nantong, Jiangsu Province - China
www.weg.net/cn

ZEST WEG Electric

6 Laneshaw Street, Longlake Extension 4,
Johannesburg, Gauteng, 1619 - South Africa
www.weg.net/za

WEG UK Contact:

Single Contact Point in the United Kingdom for compiling the
technical documentation:
Patrick O'neill Authorised Representative

WEGeuro, S.A.

Rua António Joaquim Campos Monteiro, 510,
Santa Cristina do Couto, 4780-165 - Santo Tirso - Portugal
Single Contact Point in the European Union for compiling the
technical
documentation:
Luis Filipe Oliveira Silva Castro Araújo
Authorised Representative
www.weg.net/pt

WEG TURKEY SANAYI A.S.

Mermerçiler OSB Kocaelli, Dilovasi, Köseler, Block 162, Map Section 2

WEG INDUSTRIES (INDIA) PVT.LTD.

No. E20 (North) SIPCOT Industrial Complex - Phase II - Expansion II.
Mornapalli Village Hosur 635109 Tamil Nadu

Changzhou Yatong Jiawei Electromotor Co.,LTD

No.118, Dongdu West Road, Luoyang Town, Wujin, Changzhou,
Jiangsu, China.

Antriebsstechnik KATT Hessen GmbH

(Bahnhofstrasse 66, 34576 Homburg (Efze), Germany
<https://akh-antriebsstechnik.de/>

WEG (Chang Zhou) Automation Equipment Co.,Ltd

No. 227, Xincheng Avenue, Jintan District,
Changzhou City, Jiangsu Province, China.
www.weg.net/cn

Declares under sole responsibility that WEG electric motors and components used for following motor lines

BLDC, W01, W11, W12, W20, W21, W22, W23, W30, W40, W50, W51, W60, W80, WFL, WIN, K1F, K1N, K1O, K1S, K1T, K1W, K2F, K2N, K2U, General Purpose, HGF, Roller Table, Steel Motor, PSC, Pump/Filter, Servomotor, Vertical High Thrust, Water Cooled and Wquattro

when installed, maintained, and used in applications for which they were designed, and in compliance with the relevant installation standards and manufacturer's instructions, comply with the provisions of the following relevant European Union harmonization legislation and standards, wherever applicable:

Electrical Equipment (Safety) Regulations

S.I. 2016/1101*;

The Ecodesign for Energy-Related Products Regulations and Energy Information

S.I. 2021/745*;

The Restriction of the Use of Certain Hazardous Substances in Electrical and Electronic Equipment Regulations

S.I. 2012/3032*;

Supply of Machinery (Safety) Regulations

S.I. 2008/1597 amended by S.I.2011/2157**;

Electromagnetic Compatibility Regulations

S.I. 2016/1091 (electric motors are considered inherently benign in terms of

electromagnetic compatibility);

EN 60034-1:2010 + AC:2010 / EN 60034-2-1:2014 / EN IEC 60034-5:2020 / EN 60034-6:1993/ EN 60034-7:1993 + A1:2001 / EN 60034-8:2007 + A1:2014 / EN 60034-9:2005 + A1:2007 / EN 60034-11:2004/ EN 60034-12:2017/EN IEC 60034-14:2018 / EN 60034-30-1:2014/ EN 60204-1:2018 / EN IEC 60204-11:2019 / EN IEC 63000:2018 / CLC IEC/TS 60034-30-2:2021 and CLC IEC/TS 60034-25:2024.

* Electric motors with a voltage rating higher than 1000V are not under the scope.

** Electric motors are considered partly completed machinery and are supplied with a "Declaration of Incorporation".

Declaration of Incorporation

The products above cannot be put into service until the machinery into which they have been incorporated has been declared in conformity with the Machinery Directive.

A Technical Documentation for the products above is compiled in accordance with Part 7 (b) of schedule 2 of The Supply of Machinery (Safety) Regulations 2008.

We undertake to transmit, in response to a reasoned request by the national authorities, relevant information on the product identified above (partly completed machinery) through WEG authorized representative established in the United Kingdom. The method of transmission shall be electronic or physical method and shall be without prejudice to the intellectual property rights of the manufacturer.

Signed for and on behalf of the manufacturer:

VITOR
MARCON:795
68173900
Assinado de forma digital por VITOR MARCON:79568173900
Dados: 2024.12.04 08:44:34 -03'00"

Vitor Marcon
Quality Systems and
Certifications Manager
Jaraguá do Sul
November 1, 2024

EDSON JOSE
KOSHINSKI0
2103921933
Assinado de forma digital por EDSON JOSE KOSHINSKI0
Dados: 2024.12.04 15:03:41 -03'00"

Edson Jose Koshinski
Engineering Director
Jaraguá do Sul
November 1, 2024



 +55 47 3276.4000

 motores@weg.net

 Jaraguá do Sul - SC - Brazil

Cod: 50078700 | Rev: 05 | Date (m/a): 12/2024.

The values shown are subject to change without prior notice.
The information contained is reference values.