



ATENÇÃO:

- Desconecte da rede elétrica antes de proceder qualquer trabalho neste equipamento.
- Somente profissionais qualificados podem efetuar a instalação e manutenção.
- Obedecer normas nacionais, estaduais, locais e instruções de operação.

WARNING:

- Installation and maintenance to be performed by authorized personnel only.
- User is cautioned to observe all recommendations, warnings and cautions relating to safety of personnel and equipment as well as general and local health and safety laws, codes and procedures.

ATENCIÓN:

- Desconectar de la red eléctrica antes de hacer cualquier trabajo en este equipamiento.
- Recomendase instalación por profesional calificado.
- Respetar normas nacionales y locales.
- Producto destinado a utilización en instalaciones eléctricas de baja tensión.

WARNUNG:

- Bevor irgend eine Arbeit am Gerät vorgenommen wird, muss sichergestellt sein, dass die Einheit stromlos und freigeschaltet ist.
- Sämtliche Arbeiten an der Einheit dürfen daher ausschließlich nur von Fachpersonal vorgenommen werden.
- Die jeweils geltenden nationalen, örtlichen und anlagenspezifischen Bestimmungen und Erfordernisse sind zu berücksichtigen.

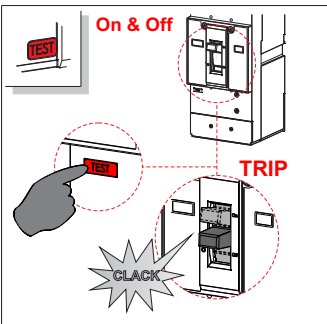
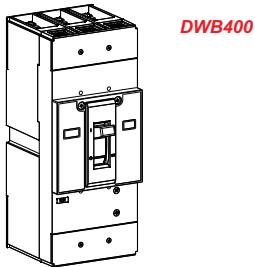

WEG IMPORTERS IN THE EUROPEAN UNION

AUSTRIA - WATT DRIVE/ANTRIEBSTECHNIK GMBH - Wöllersdorfer Str. 68, 2753 Markt Piesing, Wiener, Austria; **BELGIUM** - WEG BENELUX S.A. - Rue de l'Industrie 30/D, 1400 Nivelles, Belgium; **FRANCE** - WEG FRANCE SAS - 13 Rue du Moreillon, 38297 Saint Quentin Fallavier, France; **GERMANY** - WEG GERMANY GMBH - Geigerstraße 7, 50169 Industriegebiet Tünnich 3, Kerpen, Germany; **ITALY** - WEG ITALIA S.R.L. - Via Viganò de Vizzi, 93/95, 20092 Cisnello Balsamo, Milano, Italy; **NETHERLANDS** - WEG NETHERLANDS - Harzapoort 23C, 7575 DB Oudenzaai, Netherlands; **PORTUGAL** - WEG EURO-INDUSTRIA ELECTRICA S.A. - R. Eng. Frederico Ulrich 605, 4471-908 Maia, Portugal; **SPAIN** - WEG BIERIA INDUSTRIAL S.L. - C/ Tierra de Barros, 5-7, 28823 Costada, Madrid, Spain; **SCANDINAVIA** - WEG SCANDINAVIA AB - Box 27, 435 21, 43533 Mölnlycke, Sweden; **UNITED KINGDOM** - WEG (UK) LTD - Broad Ground Road, Redditch B988YP, Worcestershire, United Kingdom.
Information valid for WEG Group Importers.

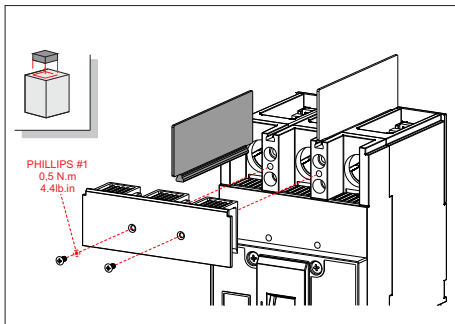
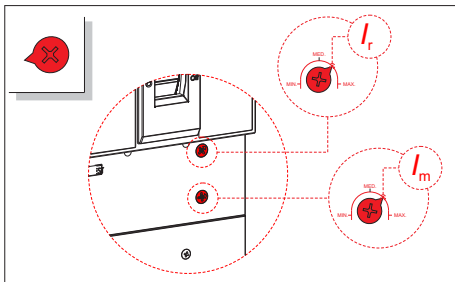

- O separador de fases deve ser instalado na entrada elétrica do disjuntor.
- Para circuitos com tensão superior a 500V, é necessário o uso de separador de fases na entrada e na saída elétrica do disjuntor de caixa moldada.
- The phase separator must be installed in the electrical input of molded case circuit breaker.
- For circuits with voltage higher than 500V, it's required the use of a phase separator at the electrical input and output of the molded case circuit breaker.
- El separador de fases debe ser instalado en la entrada eléctrica del interruptor de caja moldeada.
- Para circuitos con tensión arriba de 500V, es necesaria la utilización del separador de fases en la entrada y en la salida eléctrica del interruptor de caja moldeada.
- Phasentrenner muss auf der Einseitsungsseite installiert werden.
- Für Spannungen über 500V sind Phasentrenner auf Speisungs- und Lastseite erforderlich.

DANGER

RISK OF ELECTRIC SHOCK,
BURN OR EXPLOSION

FAILURE TO FOLLOW THESE INSTRUCTIONS WILL RESULT IN DEATH OR SEVERE INJURY.

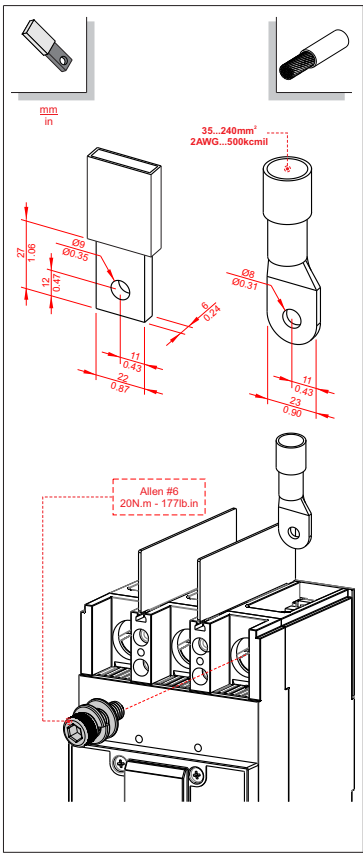

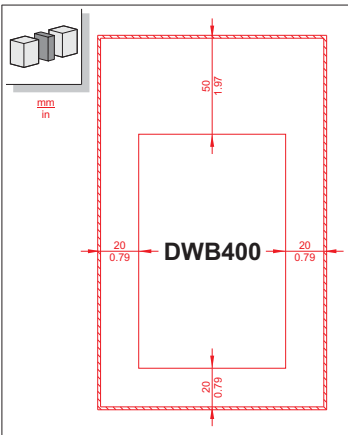
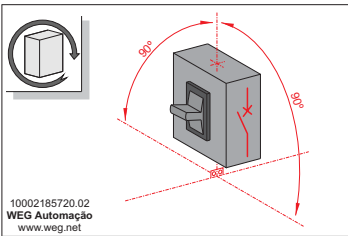

GARANTIA / WARRANTY / GARANTÍA / GEWÄHRLEISTUNG:

A WEG oferece garantia limitada contra defeitos de fabricação ou de materiais de seus produtos. Para mais informações acesse nosso site:
WEG provides a limited warranty for its products against defects in materials and workmanship. For more information access our site:
WEG ofrece garantía limitada contra defectos de fabricación o de materiales de sus productos. Para más informaciones acceda al WEB site:
WEG bietet eine beschränkte Gewährleistung für ihre Produkte gegen Herstellungs- und Materialfehler. Für weitere Informationen besuchen Sie bitte unsere Webseite:
www.weg.net/warranty-automation

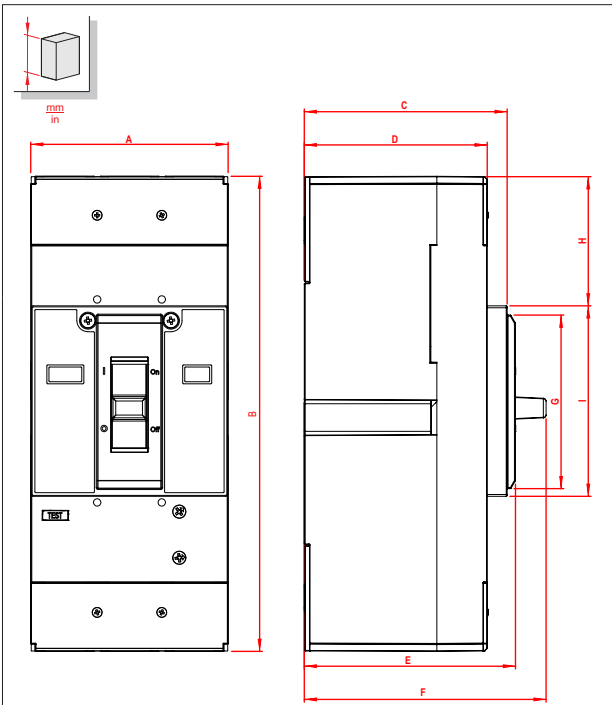

	A	B	C	D	E	F	G	H	I
DWB400 - 3P	107 4.21	257,5 10.14	109,9 4.33	99,1 3.90	114,4 4.50	131 5.16	94 3.70	70 2.76	103,2 4.06
DWB400 - 4P	142 5.60	323 12.72							

