

# TPDflex DC Converters

## Frame D

### Hardware Service Manual

Language: English

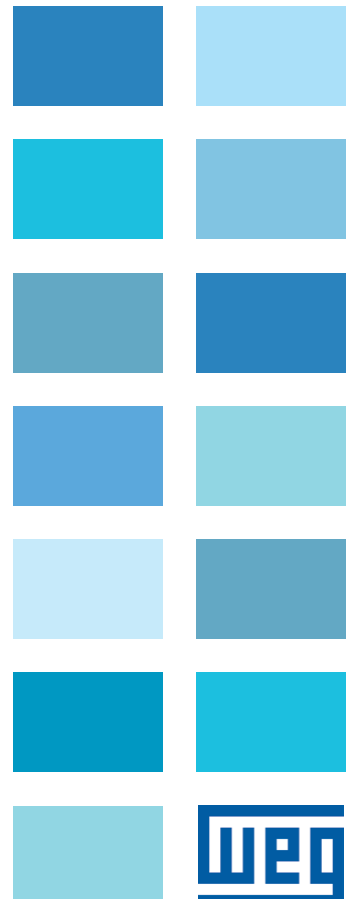

## Important User Information

Read this document and any additional resources regarding installation, configuration, and operation of this equipment before installing, configuring, operating, or maintaining it. Users must follow installation and wiring instructions and comply with all applicable codes, laws, and standards.

All activities, including installation, adjustments, commissioning, use, assembly, disassembly, and maintenance, must be performed by properly trained personnel following applicable safety practices.

Using the equipment in ways not specified by the manufacturer may reduce its protective features.

Examples and diagrams are for illustrative purposes only and do not replace proper engineering judgment for actual installations.

No patent liability is assumed regarding the use of the information, circuits, equipment, or software described.

Reproduction of this manual, in whole or in part, is prohibited without written permission.

Notes in this manual highlight safety considerations where necessary.



**WARNING** Identifies information about practices or circumstances that can cause an explosion in a hazardous environment, which may lead to personal injury or death, property damage, or economic loss.



**ATTENTION** Identifies information about practices or circumstances that can lead to personal injury or death, property damage, or economic loss. Attentions help you identify a hazard, avoid a hazard, and recognize the consequence.

**IMPORTANT** Identifies information that is critical for successful application and understanding of the product.

These labels may also be on or inside the equipment to provide specific precautions.



**SHOCK HAZARD** Labels may be on or inside the equipment, for example, a drive or motor, to alert people that dangerous voltage may be present.



**BURN HAZARD** Labels may be on or inside the equipment, for example, a drive or motor, to alert people that surfaces may reach dangerous temperatures.



**ARC FLASH HAZARD** Labels may be on or inside the equipment, for example, a motor control center, to alert people to potential Arc Flash. Arc Flash will cause severe injury or death. Wear proper Personal Protective Equipment (PPE). Follow ALL Regulatory requirements for safe work practices and for Personal Protective Equipment (PPE).

The following icon may appear in the text of this document.



Identifies information that is useful and can help to make a process easier to do or easier to understand.

	<b>Preface</b>	
	Summary of Changes .....	7
	<b>Chapter 1</b>	
<b>Before You Begin Testing, Maintenance, or Repairs</b>	Introduction .....	9
	General Safety Precautions .....	10
	Hardware Description .....	11
	Commonly Used Tools .....	12
	Service Tools .....	12
	Software Tools .....	12
	<b>Chapter 2</b>	
<b>Component Test Procedures</b>	Introduction .....	13
	Save the Parameter Configuration .....	14
	Save to a HIM Set .....	14
	Save Parameters to a Project File Using Connected Components Workbench Software .....	15
	Save Parameters to an Offline Node File Using DriveExecutive Software .....	16
	Visual Component Inspection .....	16
	Troubleshoot a Control Power Supply Failure .....	16
	Testing the Switching Power Supply and Pulse Transformer Boards .....	17
	Testing the Control and Field Board Connections .....	18
	Troubleshoot an AC Undervoltage Fault .....	23
	Troubleshoot an Armature Bridge Failure .....	25
	Troubleshoot a Field Current Loss Fault .....	29
	Low or Incorrect Field Current .....	29
	No Field Current .....	31
	Power Component Test Procedures .....	33
	Check the Armature SCR Modules .....	33
	Check the Pulse Transformer Board .....	37
	Check the Field SCR/Dual Diode Module .....	38
	Speed Feedback Device Tests .....	40
	Check the Encoder .....	40
	Check the DC Tachometer .....	41
Check the Resolver Interface Board .....	42	
Thermistors and Thermal Switches .....	44	
Relay Outputs .....	44	
Create a Fault Report .....	45	
What You Need When You Call Tech Support .....	45	
.....	46	
	<b>Chapter 3</b>	
<b>Access Procedures</b>	Introduction .....	47
	Remove Power from the Drive .....	48
	Field Circuit Fuse Removal and Installation .....	49

Remove the Field Circuit Fuses .....	49
Install the Field Circuit Fuses .....	50
DPI / HIM Assembly Removal and Installation .....	50
Remove the DPI / HIM Assembly from the Protective Cover .....	50
Install the DPI / HIM Assembly on the Protective Cover .....	51
Protective Cover Removal and Installation .....	51
Remove the Protective Covers .....	51
Install the Protective Covers .....	53
Open and Close the Control Panel .....	53
Open the Control Panel .....	53
Close the Control Panel .....	54
Communication Adapter and EMI Shield Removal and Installation .....	54
Remove the Communication Adapter and EMI Shield .....	54
Install the Communication Adapter and EMI Shield .....	56
Switching Power Supply Fuse Removal and Installation .....	56
Remove the Fuse on the Switching Power Supply Circuit Board .....	56
Install the Fuse on the Switching Power Supply Circuit Board .....	58
Remove the Resolver Feedback and Interface Circuit Boards .....	58
Install the Resolver Feedback and Interface Circuit Boards .....	62
I/O Expansion Circuit Board Removal and Installation .....	62
Remove the I/O Expansion Circuit Board .....	62
Install the I/O Expansion Circuit Board .....	64
115V AC to 24V DC I/O Converter Circuit Board Removal and Installation .....	64
Remove the 115V AC to 24V DC I/O Converter Circuit Board .....	64
Install the 115V AC to 24V DC I/O Converter Circuit Board .....	65
Control Circuit Board Removal and Installation .....	65
Remove the Control Circuit Board .....	65
.....	69
Install the Control Circuit Board .....	70
Switching Power Supply Circuit Board Removal and Installation .....	70
Remove the Switching Power Supply Circuit Board .....	70
Install the Switching Power Supply Circuit Board .....	71
Pulse Transformer Circuit Board Removal and Installation .....	71
Remove the Pulse Transformer Circuit Board .....	71
Install the Pulse Transformer Board .....	74
Field Circuit Board Removal and Installation .....	75
Remove the Field Circuit Board .....	75
Install the Field Circuit Board .....	76
Field SCR and Dual Diode Module Removal and Installation .....	76
Remove the Field SCR and Dual Diode Modules .....	76
Install the Field SCR and Dual Diode Modules .....	78
Field Fuse Holder Removal and Installation .....	79
Remove the Field Fuse Holder .....	79
Install the Field Fuse Holder .....	81
Fan Starting Capacitor Removal and Installation .....	81
Remove the Fan Starting Capacitor .....	81
Install the Fan Starting Capacitor .....	82
Series A Fan Circuit Board Removal and Installation .....	83
Remove the Series A Fan Circuit Board .....	83
Install the Series A Fan Circuit Board .....	83

Series B Fan Circuit Board Removal and Installation .....	84
Remove the Series B Fan Circuit Board .....	84
Install the Series B Fan Circuit Board .....	84
Series A Fan Assembly Removal and Installation .....	85
Remove the Series A Fan Assembly .....	85
Install the Series A Fan Assembly .....	86
Series B Fan Assembly Removal and Installation .....	87
Remove the Series B Fan Assembly .....	87
Install the Series B Fan Assembly .....	88
Series C Fan Assembly Removal and Installation .....	89
Remove the Series C Fan Assembly .....	89
Install the Series C Fan Assembly .....	90
AC Current Transducers Removal and Installation .....	91
Remove the AC Current Transducers .....	91
Install the AC Current Transducers .....	95
Overvoltage Clipping Circuit Board Fuse Removal and Installation .....	95
Remove the Overvoltage Clipping Circuit Board Fuses .....	95
Install the Overvoltage Clipping Circuit Board Fuses .....	95
Overvoltage Clipping Circuit Board Removal and Installation .....	96
Remove the Overvoltage Clipping Circuit Board .....	96
Install the Overvoltage Clipping Circuit Board .....	97
Armature Leg Fuse Removal and Installation .....	97
Remove the Armature Leg Fuse .....	97
Install the Armature Leg Fuse .....	99
SCR Module Leg Assembly Removal and Installation .....	99
Remove the SCR Module Leg Assembly .....	99
Install the SCR Module Leg Assembly .....	104
Bimetal Thermostat Removal and Installation .....	105
Remove the Bimetal Thermostat .....	105
Install the Bimetal Thermostat .....	105
Discharge Resistors Removal and Installation .....	105
Remove the Discharge Resistors .....	105
Install the Discharge Resistors .....	107
Inrush Limiting Resistor Removal and Installation .....	107
Remove the Inrush Limiting Resistor .....	107
Install the Inrush Limiting Resistor .....	110
Snubber Capacitors Removal and Installation .....	110
Remove the Snubber Capacitors .....	110
Install the Snubber Capacitors .....	110
Snubber Resistors Removal and Installation .....	111
Remove the Snubber Resistors .....	111
Install the Snubber Resistors .....	112
<b>Chapter 4</b>	
Test With the Motor, Without a Mechanical Load .....	113
<b>Appendix A</b>	
List of Schematic Diagrams .....	115

## Start Up After Repair

## Schematics

**Circuit Board Layouts and Connections**

**Appendix B**

List of Circuit Board Layouts..... 127  
Pulse Transformer Board..... 128  
Switching Power Supply Board ..... 131  
Control Board ..... 132  
Field Board..... 134  
Overvoltage Clipping Board..... 134

**Flow Charts**

**Appendix C**

List of Flow Charts ..... 137  
Control Power Supply Failure ..... 137  
Field Current Loss Failure ..... 138  
    No Field Current ..... 139  
    Low or Incorrect Field Current ..... 140

**Index ..... 141**

Do you need help? ..... 145

This manual contains component test and hardware replacement information for TPDflex DC frame D drives, 250...1400 Hp (186...1044 kW).

This manual is intended for qualified service personnel responsible for troubleshooting and repairing PowerFlex DC drives. You should have previous experience with, and basic understanding of, electrical terminology, procedures, required troubleshooting equipment, equipment protection procedures and methods, and safety precautions.

It is highly recommended that you obtain a copy of the TPDflex DC Converters User Manual, publication 1S7TFLEXUMO, which contains fault/alarm and programming information to assist you in troubleshooting drive errors and determining if repairs are necessary. Please contact your local Allen-Bradley distributor or the Rockwell Automation sales office for information about related publications and how to obtain manuals.

## Summary of Changes

This manual contains new and updated information in the following sections.

<b>Topic</b>	<b>Page</b>
Added Series B Control Board Testpoints - Upper Left	20
Added Series B Control Board Testpoints - Upper Right	22
Added Combined AC Line Input Signal Testpoints Series B	24
Added Series B figure for Good SCR Gate Pulse and Armature Current Signals	27
Added Series B Good SCR Armature Voltage and Motor Current Signal	27
Added Series B Open Thyristor	28
Added Jumper Settings Series A table	66
Added Jumper Settings Series B table	67
Added Four Series B Control Circuit Boards Replacement	68, 69
Added Series B Control Board Layout	133

**Notes:**

## Before You Begin Testing, Maintenance, or Repairs

### Introduction

This chapter provides information you should know before you begin tests, maintenance or repairs on drive components.

<b>Topic</b>	<b>Page</b>
General Safety Precautions	10
Hardware Description	11
Commonly Used Tools	12

## General Safety Precautions

Read the following precautions before you begin testing components, performing maintenance or repairing the drive.



**ATTENTION:** Only qualified personnel familiar with DC drives and associated machinery should plan or implement the installation, startup, and subsequent maintenance of the system. Failure to comply may result in personal injury and/or equipment damage.



**ATTENTION:** This drive contains ESD (Electrostatic Discharge) sensitive parts and assemblies. Static control precautions are required when installing, testing, servicing or repairing this assembly. Component damage may result if ESD control procedures are not followed. If you are not familiar with static control procedures, reference A-B publication 8000-4.5.2, "Guarding Against Electrostatic Damage" or any other applicable ESD protection handbook.



**ATTENTION:** Severe injury or death can result from electrical shock, burn, or unintended actuation of controlled equipment. Hazardous voltages may exist in the drive enclosure even with the circuit breaker in the off position. Recommended practice is to disconnect and lock out control equipment from power sources. If it is necessary to work in the vicinity of energized equipment, the safety related work practices of NFPA 70E, Electrical Safety Requirements for Employee Workplaces, must be followed. DO NOT work alone on energized equipment.



**ATTENTION:** Potentially fatal voltages may result from improper usage of an oscilloscope and other test equipment. The oscilloscope chassis may be at a potentially fatal voltage if not properly grounded. If an oscilloscope is used to measure high voltage waveforms, use only a dual channel oscilloscope in the differential mode with X 100 probes. It is recommended that the oscilloscope be used in the A minus B Quasi-differential mode with the oscilloscope chassis correctly grounded to an earth ground.



**ATTENTION:** Remove power before making or breaking cable connections. When you remove or insert a cable connector with power applied, an electrical arc may occur. An electrical arc can cause personal injury or property damage by:

- sending an erroneous signal to your system's field devices, causing unintended machine motion
- causing an explosion in a hazardous environment

Electrical arcing causes excessive wear to contacts on both the module and its mating connector. Worn contacts may create electrical resistance.



**ATTENTION:** HOT surfaces can cause severe burns. **Do not** touch the heatsink surface during operation of the drive. After disconnecting power allow time for cooling.

## Hardware Description

The TPDflex DC Converter contains a power structure that has an armature and field supply. The armature supply consists of a three-phase, full wave rectified, dual bridge, capable of two or four quadrant output. The field supply consists of single phase, full wave rectified bridge. Also associated with the power structure are incoming line protection devices and contactor and dynamic brake control circuits.

Frame D drives may contain series B fan components. Verify that you are working on a Frame D, series A or series B drive by checking the data nameplate label on the lower right side of the drive. The frame size is printed just above the serial number in the lower right corner of the label. The series letter is printed on the upper right corner of the label.

**Figure 1 - Drive Data Nameplate Label**

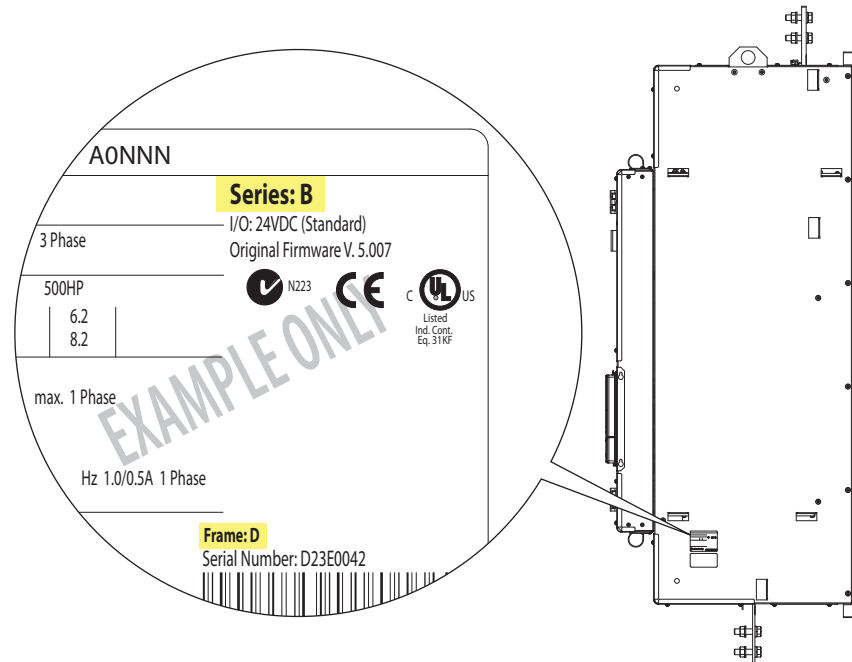

## Commonly Used Tools

## Service Tools

This list of basic service tools which will cover needs of tools for repair and maintenance measurements.

Item	Details
Digital Multimeter	Digital multimeter, capable of ac and dc voltage, continuity, resistance and forward diode bias tests. Fluke model 87 III or equivalent (recommended).
Oscilloscope	Portable, digitizing, dual channel scope, with isolation
Current clamp	3x drive rated armature current output
Soldering station	Soldering / de soldering
Torque wrench	1...12 N•m
Torque wrench	6...50 N•m
box wrench	7 mm, 8 mm, 10 mm, 13 mm, 17 mm, 19 mm, 22 mm
socket extension	230 mm
Wrench	7 mm, 8 mm, 10 mm, 13 mm, 17 mm, 19 mm, 22 mm
Wire cutter	
Nose pliers	
Crimping tools	For cable terminals 1.5...240
Angle wrench	
Screw drivers:	
Flat nose	7x2 mm
Hexalobular	T15, T25
Phillips®	#1, 2, 3
Hexagonal wrench	#4, 5, 6
ESD-protected place of work	Working surface, floor covering, seat and ground connections
ESD-protective clothing	Wrist wrap, shoes, overall clothing (coat)

Phillips® is a registered trademark of Phillips Screw Company.

## Software Tools

You can use Connected Components Workbench™ software and DriveExecutive software for configuring and monitoring drive parameters.

## Component Test Procedures

### Introduction

This chapter provides general procedures for inspecting and testing the major components of the drive and includes recommendations for repairs. Due to the technical nature of this product and the variety of possible applications, not all possible fault conditions and troubleshooting solutions can be described in this manual.

Topic	Page
Save the Parameter Configuration	14
Visual Component Inspection	16
Troubleshoot a Control Power Supply Failure	16
Troubleshoot an AC Undervoltage Fault	23
Troubleshoot an Armature Bridge Failure	25
Troubleshoot a Field Current Loss Fault	29
Power Component Test Procedures	33
Speed Feedback Device Tests	40
Thermistors and Thermal Switches	44
Relay Outputs	44
Create a Fault Report	45
What You Need When You Call Tech Support	45

**IMPORTANT** Using the diagnostic tests in this chapter should only be performed by qualified personnel and only when other corrective actions have failed. All tests assume that the control board connections have been properly made.











For common drive symptoms and corrective actions and fault troubleshooting information, see Chapter 4 “Troubleshooting” in the TPDflex DC Converters User Manual, publication 1S7TFEXUM0.

## Save the Parameter Configuration

It is recommended that you save the drive and communication adapter parameter configuration to a HIM set or by up loading the drive and adapter parameters to an offline node file using Connected Components Workbench™ or DriveExecutive™ software before performing any service or testing on the drive. HIM sets are files stored in permanent nonvolatile HIM memory.

### Save to a HIM Set

Follow these steps to save the drive and communication adapter parameters to a HIM set.

1. On the HIM, access the **Memory Storage** menu.
2. Select the **HIM CopyCat** menu and press .
3. Select **Device -> HIM** and press .
4. Do one of the following:
  - If there are no existing HIM sets, enter a name using the  and  buttons to select the desired characters and press .
  - If there is an existing HIM set, press  to overwrite it, or select **No** using the  button and use the  and  buttons to select the desired characters. Then press .

The HIM set will be saved to nonvolatile memory.

## Save Parameters to a Project File Using Connected Components Workbench Software

You can save all drive and communication adapter parameters in the drive to a project file on your computer using Connected Components Workbench software. A project file (\*.ccwsln) contains all information about the node, including the necessary databases. Follow these steps to save a project file for your drive.

1. From the Connected Components Workbench software, with the project for your drive open, click Upload in the toolbar.
  - If a communication path has previously been established with the device, a progress window opens. When the connection is complete, the Upload window opens. Continue with step 2.
  - If a communication path has not previously been established with the device, the Connection Browser opens. Select the device from which you want to upload configuration settings and click OK. A progress window opens. When the connection is complete, the Upload window opens.
2. In the Upload window, do one of the following:
  - If you do not want to change the communication path, continue with step 3.
  - If you want to change the established communication path, click Change. The Connection Browser opens. Select the device from which you want to upload configuration settings and click OK. A status window opens and shows the progress of the connection.

**Note:** The communication path can only be changed when disconnected from the device.

3. Click Error Check Upload to upload the configuration settings from the connected device, parameter-by-parameter, while checking for errors. This option is only available when a device supports both an optimized (block) upload and parameter-by-parameter upload.
4. In the Upload window, do one of the following:
  - If you want to upload the configuration for all ports for the device, click Upload Entire Device.
  - If you only want to upload the drive configuration, click Upload Port 0.
  - If you do not want to upload the configuration for a specific ports for the device, click Advanced (if available). The Select Ports to Upload window opens. Select the checkbox of the ports that you do not want to upload from the drive. Click Upload.

**Note:** If the device from which you are uploading has a different rating and/or firmware revision than the device in your project, the Port Mismatch window opens. Click Details to open the Device Type Mismatch or Revision Mismatch window and view the rating and/or revision level differences. Click Continue to complete the upload and change the rating and/or revision of the device in your project to match the online device. Click Cancel to cancel the upload.

The Upload status window opens to indicate the progress of the upload operation.

- Clicking **X** will cancel the upload. When the upload has completed, a message appears in the window to confirm that the upload completed successfully.
- Clicking **✓** will close the message window, or click Close window when complete before the upload finishes.

5. From the File menu, choose Save.

## Save Parameters to an Offline Node File Using DriveExecutive Software

You can save all drive and communication adapter parameters in the drive to an offline database file on your computer using DriveExecutive. software An offline node file (\*.dno) contains all information about the node, including the necessary databases. Follow these steps to save an offline database file for your drive.

1. From the DriveExecutive software, from the Drive menu, choose Connect to Drive.
2. From the Connect to Drive dialog box, select the drive for which you want to save the parameter configuration and click OK.
3. Click  (Upload) on the toolbar.
4. A dialog displays the status of the upload operation. Click Cancel to cancel the operation.
5. From the File menu, click Save.
6. In the Save As dialog box, enter a name for the file and click Save.

## Visual Component Inspection

Visually inspect the drive circuit boards and power components before energizing the drive for any of the component test procedures.

1. Read the General Safety Precautions on page [10](#).
2. Remove power from the drive. See Remove Power from the Drive on page [48](#).
3. Open the control pan. See Open the Control Panel on page [53](#).
4. Remove the protective covers from the drive. See Protective Cover Removal and Installation on page [51](#).
5. Check components for burn marks, breakage or foil delamination on all circuit boards.

Replace any of these components without further testing if they show evidence of burn marks, breakage or foil delamination.

## Troubleshoot a Control Power Supply Failure

If a drive Power Failure fault (F3) has occurred and the drive is inoperable via the HIM or other means of control, complete the steps below to determine where the control power failure has occurred.

1. Read the General Safety Precautions on page [10](#).
2. Remove the bottom control panel and I/O and control terminal covers from the drive. See Protective Cover Removal and Installation on page [51](#).
3. Measure the signal voltage at the testpoints on the control board as indicated in the following table.

Name	Testpoint	For Testpoint Location See...	Associated Connector-Pin	Description
+ 5V	XY5	<a href="#">Figure 2</a> on page <a href="#">19</a>	XA-1 / XA-3 / XA-5	+5V digital supply
GNDD	XY6	<a href="#">Figure 2</a> on page <a href="#">19</a>	XA-2 / XA-4 / XA-6	+5V digital supply ground
GNDD	XY7	<a href="#">Figure 4</a> on page <a href="#">21</a>	XA-2 / XA-4 / XA-6	+5V digital supply ground
+15V	XY12	<a href="#">Figure 2</a> on page <a href="#">19</a>	XA-9 / XA-10	+15V analog supply
GNDA	XY10	<a href="#">Figure 2</a> on page <a href="#">19</a>	XA-11 / XA-12	15V analog supply ground

Name	Testpoint	For Testpoint Location See...	Associated Connector-Pin	Description
-15 V	XY11	<a href="#">Figure 2</a> on page 19	XA-13 / XA-14	-15V analog supply
+24V	XY8	<a href="#">Figure 2</a> on page 19	XA-16	+24V terminal block
GNDV	XY9	<a href="#">Figure 2</a> on page 19	XA-15	+24V terminal block ground
+5VEXP	+5VEXP	<a href="#">Figure 4</a> on page 21	XP3-1 / XP3-2 / XP3-3	+5V for DPI expansion
+12VEXP	+12VEXP	<a href="#">Figure 4</a> on page 21	XP3-4 / XP3-5	+12V for DPI expansion
OVEXP	OVEXP	<a href="#">Figure 4</a> on page 21	XP3-7 / XP3-8 / XP3-9	DPI expansion ground

Note: For a flow chart version of the steps that follow, see Control Power Supply Failure on page [137](#).

4. If any of the signals in the table above is incorrect or missing, verify that either 115 VAC or 230 VAC voltage is present at terminals U2 and V2 (control circuit power input).
  - If the voltage is present and correct, continue with step 5 below.
  - If the voltage is incorrect or missing, remove control power and verify the wiring and power source to U2, V2 and correct any problems. Test the voltage level again to verify that it is correct. If the voltage is correct, but the drive is still inoperable, continue with step 5 below.
5. Remove AC control power from terminals U2 and V2 and remove and test the fuse (F1) at the top of the drive. See Switching Power Supply Fuse Removal and Installation on page [56](#) for fuse location.
  - If the fuse is blown, continue with step 6.
  - If the fuse is not blown, replace the switching power supply board.
6. Replace the fuse on the switching power supply board. See Switching Power Supply Fuse Removal and Installation on page [56](#).
7. Disconnect the cable at connector XA on the control board. See [Figure 36](#) on page [132](#) for location of connector XA.
8. Apply AC control power to the drive.
  - If the fuse blows, continue with Testing the Switching Power Supply and Pulse Transformer Boards on page [17](#) below.
  - If the fuse does not blow, continue with Testing the Control and Field Board Connections on page [18](#).

## Testing the Switching Power Supply and Pulse Transformer Boards

1. Remove power from the drive.
2. Replace the fuse on the switching power supply board. See Switching Power Supply Fuse Removal and Installation on page [56](#).
3. Remove the switching power supply board from the drive. See Remove the Pulse Transformer Circuit Board on page [71](#).
4. Reapply power to the switching power supply board only.
  - If the power supply fuse does not blow, continue with step 5 below.
  - If the power supply fuse blows, replace the switching power supply board.
5. Remove all incoming AC voltage from the drive.

6. Check all external wiring connected to the pulse transformer board, including the motor PTC if used, for a possible short circuit condition. Repair any short circuit conditions if found.
7. If no short circuit conditions exist, replace the pulse transformer board.

### **Testing the Control and Field Board Connections**

1. Using an ohmmeter, check all input and output wiring on terminals 1..40 on terminal blocks TB1 and TB2 on the control board for a possible short circuit condition. Repair any short circuit conditions if found.
2. If an encoder and/or tachometer is used, use an ohmmeter to check all wiring on the respective terminals for a possible short circuit condition. Repair any short circuit conditions if found.
3. Remove the cables from connector XR and XFCD on the control board and use an ohmmeter to check between all voltage test points and common on the control board for possible short circuit conditions. The ohmmeter measurements should be greater than 200 k $\Omega$  . If any low resistance measurements are found, replace the control board.
4. Using an ohmmeter, measure between pins 1 and 2 and pins 3 and 2 on the XFCD cable connector. The resistance measurement for both tests should be greater than 200 k $\Omega$  . If a lower resistance value is measured, replace field board.

Figure 2 - Series A Control Board Testpoints - Upper Left

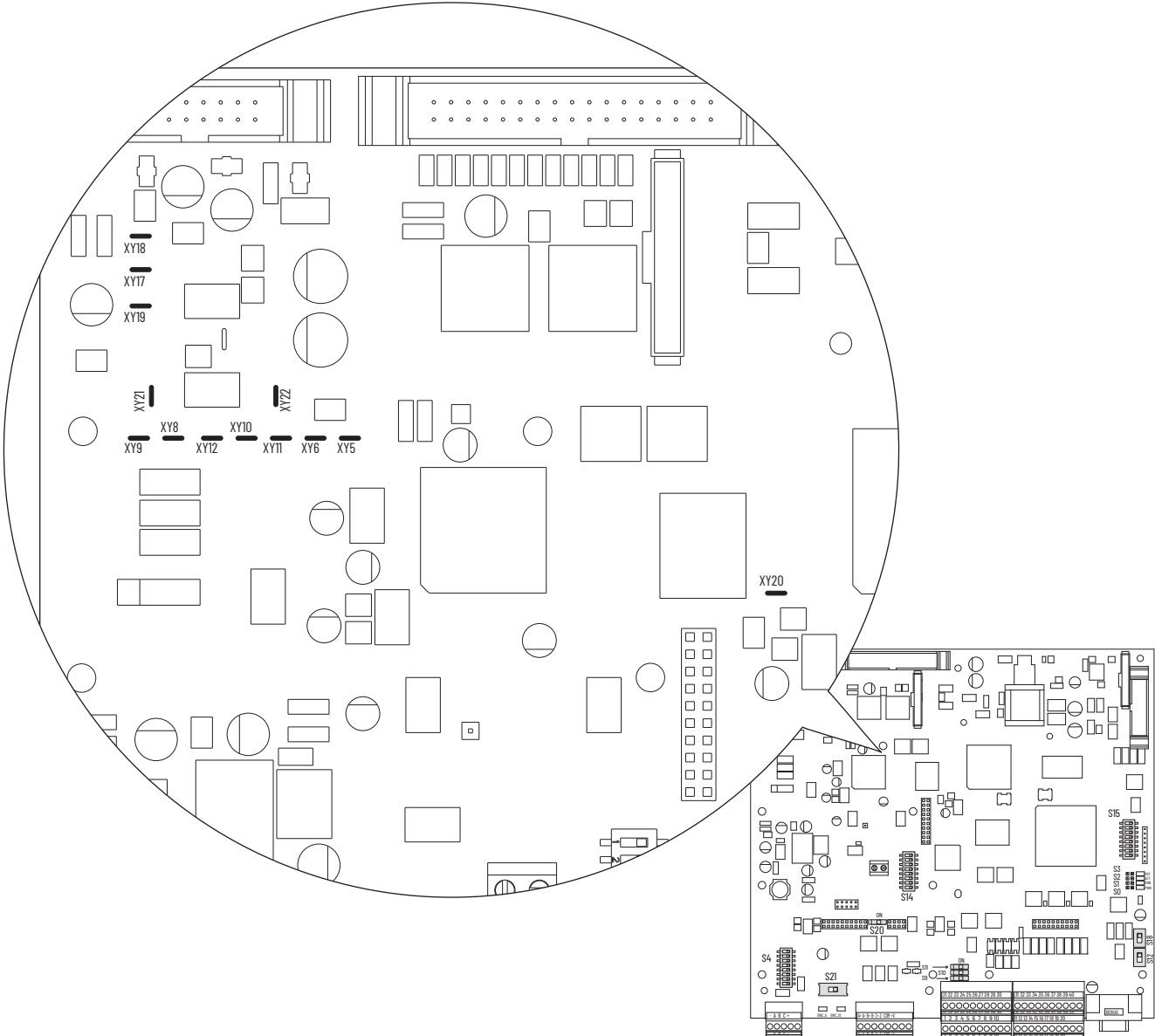

Figure 3 - Series B Control Board Testpoints - Upper Left

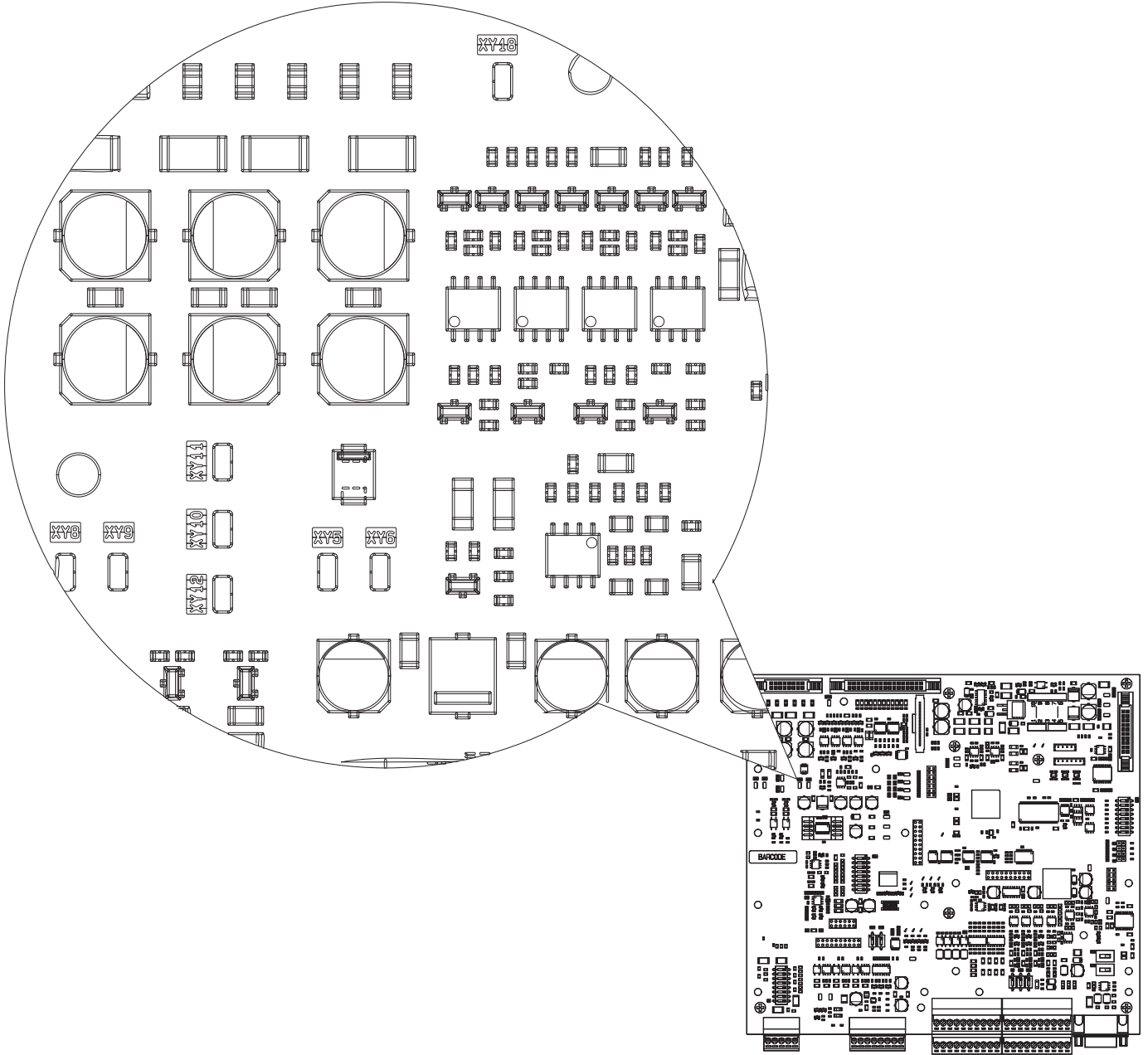

Figure 4 - Series A Control Board Testpoints - Upper Right

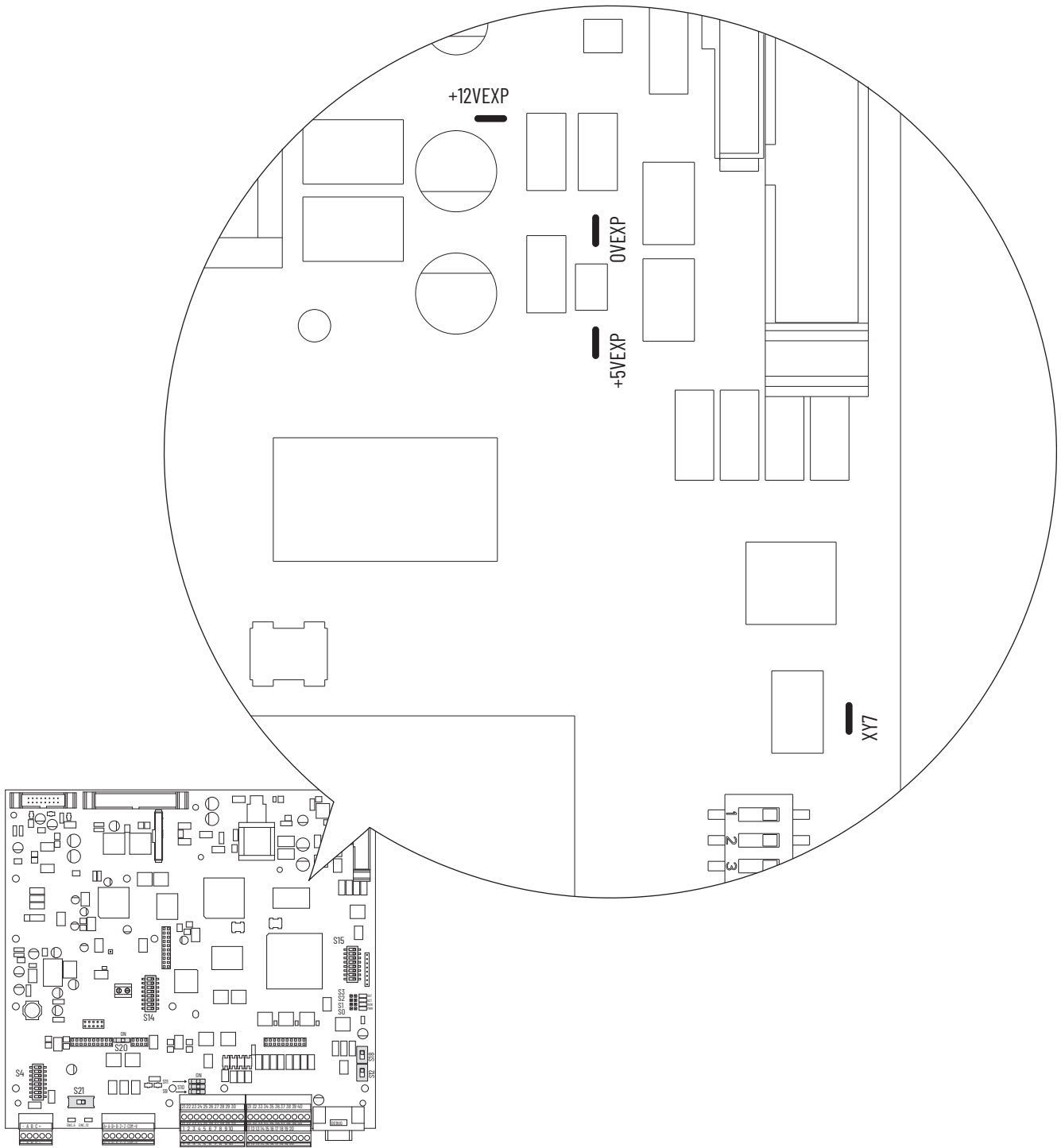
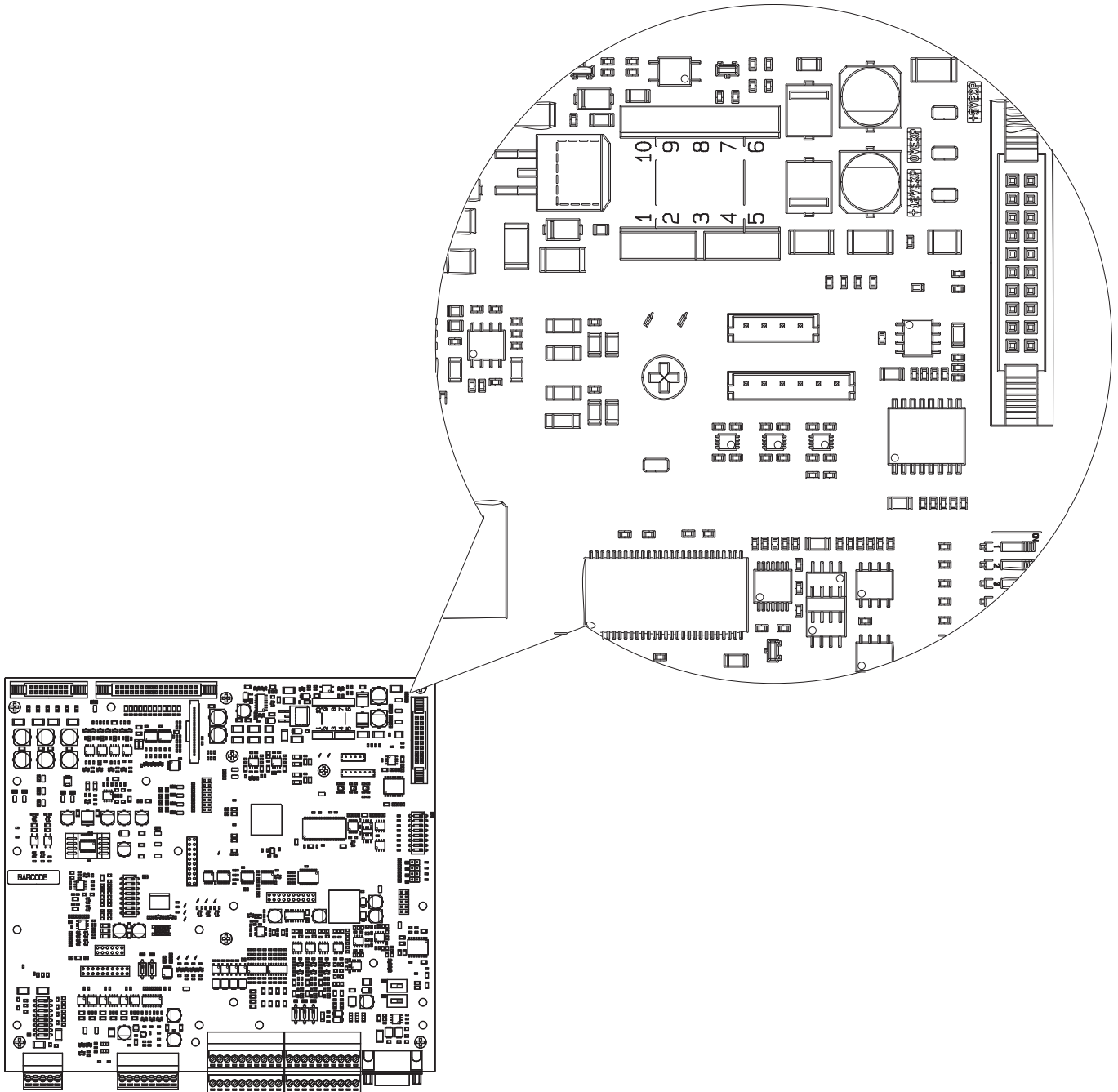

Figure 5 - Series B Control Board Testpoints - Upper Right



## Troubleshoot an AC Undervoltage Fault

If the drive faults with an AC Undervoltage Fault (F4), or parameter 466 [AC Line Voltage] does not equal the expected incoming AC line voltage, measure the AC line input signals as directed in the steps below.

1. Read the General Safety Precautions on page 10.
2. Remove the bottom control panel and I/O and control terminal covers from the drive. See Protective Cover Removal and Installation on page 51.
3. Using a voltmeter, measure the voltage at terminals U, V, and W of the drive.

Note: If an AC input contactor is used, the voltage must be measured on both the input and output sides of the contactor.

If any of the voltage measurements is incorrect or missing, remove incoming AC power and verify the wiring to the drive and the power supply source and correct any problems.

4. Using a voltmeter, measure the combined voltages of the AC lines on the following testpoints on the control board (all waveforms have a 2.5V offset). See Figure 2 on page 19 and Figure 4 on page 21 for location of the testpoints. Also, see Figure 21 on page 121 for a schematic diagram.

**Table 1 - Combined AC Line Input Signal Testpoints Series A**

Incoming AC Line Voltage	Phases	Measure From Testpoint	...	To Testpoint	Peak to Peak Measurement	RMS Measurement
240 VAC	V and U	XY22	...	XY18	1.42 VAC	0.500 V
	V and W	XY21	...	XY18		
480 VAC	V and U	XY22	...	XY18	2.95 VAC	1.040 V
	V and W	XY21	...	XY18		
575 VAC	V and U	XY22	...	XY18	2.85 VAC	1.007 V
	V and W	XY21	...	XY18		
690 VAC	V and U	XY22	...	XY18	3.45 VAC	1.220 V
	V and W	XY21	...	XY18		

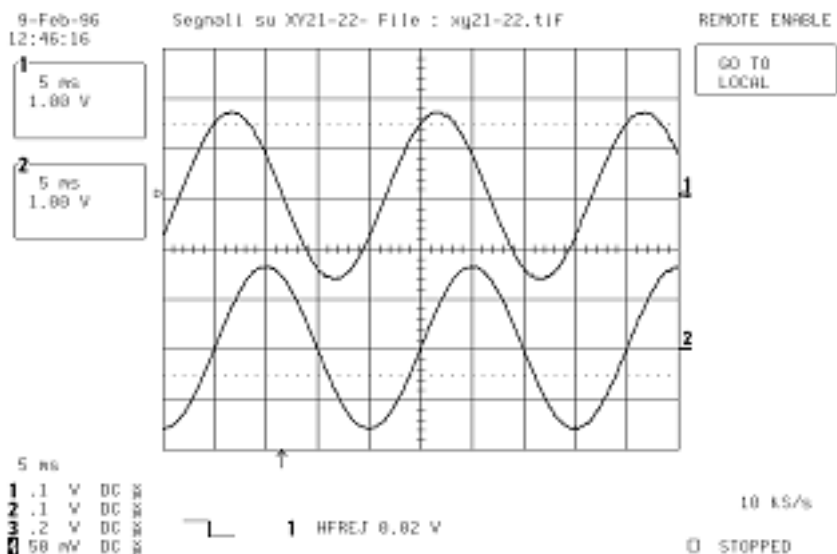

**Table 2 - Combined AC Line Input Signal Testpoints Series B**

Incoming AC Line Voltage	Phases	Measure from Testpoint	...	To Testpoint	Peak to Peak Measurement	RMS Measurement
240V AC	V and U	XY22	...	XY18	0.93V AC	0.330V
	V and W	XY21	...	XY18		
480V AC	V and U	XY22	...	XY18	1.86V AC	0.660V
	V and W	XY21	...	XY18		
575V AC	V and U	XY22	...	XY18	1.79V AC	0.630V
	V and W	XY21	...	XY18		
690V AC	V and U	XY22	...	XY18	1.80V AC	0.640V
	V and W	XY21	...	XY18		

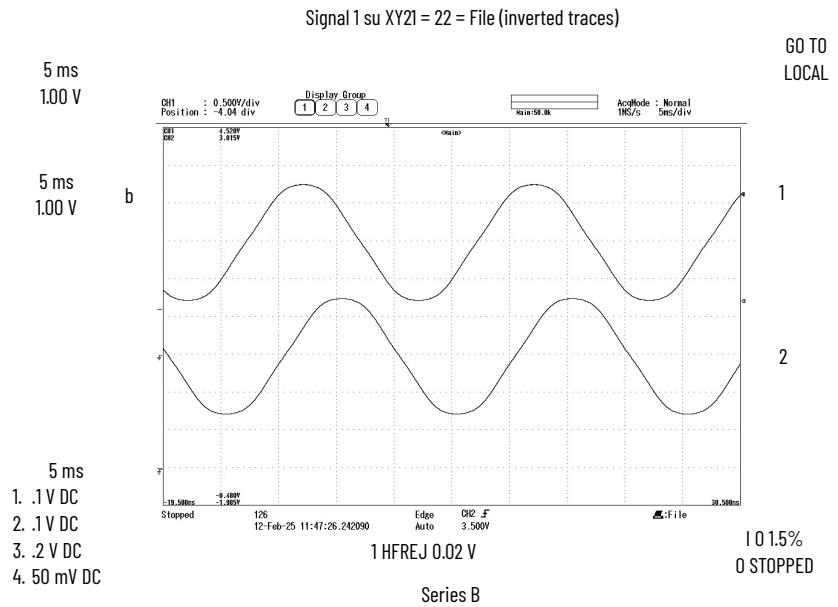

- If any of the voltage measurements above are incorrect or missing, continue with step 5 below.
  - If the voltage measurements above are correct but the value of parameter 466 [AC Line Voltage] is incorrect, replace the control board.
5. Remove the ribbon cable connected to XR on the control board and pulse transformer board and test the continuity of the cable using the measurements in [Table 21](#) on page [130](#).

If the measurements on the XR cable are correct, replace the pulse transformer board.

## Troubleshoot an Armature Bridge Failure

If the drive is running unstable or faults with an Overcurrent Fault (F13) an armature bridge failure may have occurred. All of the signals going to and coming from the SCR bridges are transmitted via the ribbon cable connected to XR on the control board and can be measured at these points. See [Figure 36](#) on page [132](#) for location of the XR connector on the control board.

These checks cannot be completed with an AC contactor in use.

1. Read the General Safety Precautions on page [10](#).
2. Remove the bottom control panel and I/O and control terminal covers from the drive. See Protective Cover Removal and Installation on page [51](#).
3. If using a DC output contactor, disconnect the cable from XR on the control board and measure the signal for each SCR gate as indicated in the table below:

Signal Name	XR Cable Pin	Gate		Note
		MP	MN	
IT1	27	G1	G04	
IT2	29	G2	G05	
IT3	31	G3	G06	
IT4	21	G4	G01	
IT5	23	G5	G02	
IT6	25	G6	G03	
MN	33	-	-	Negative bridge MN - active when high (+5V)
MP	34	-	-	Positive bridge MP - active when high (+5V)

[Figure 6](#), [Figure 7](#), and [Figure 8](#) on page [26](#) are examples representing gate pulse, current and voltage signal measurements taken on an SCR. In the figures below:

- The current signal is taken on the testpoint XY17 (+2.5V offset; +0.6V=Drive size current).
- The voltage signal is taken on the testpoint XY19 (+2.5V offset, inverted traces).
- The ground signal is taken on either testpoint XY10 or XY18.

**Figure 6 - Good SCR Gate Pulse and Armature Current Signals Example**

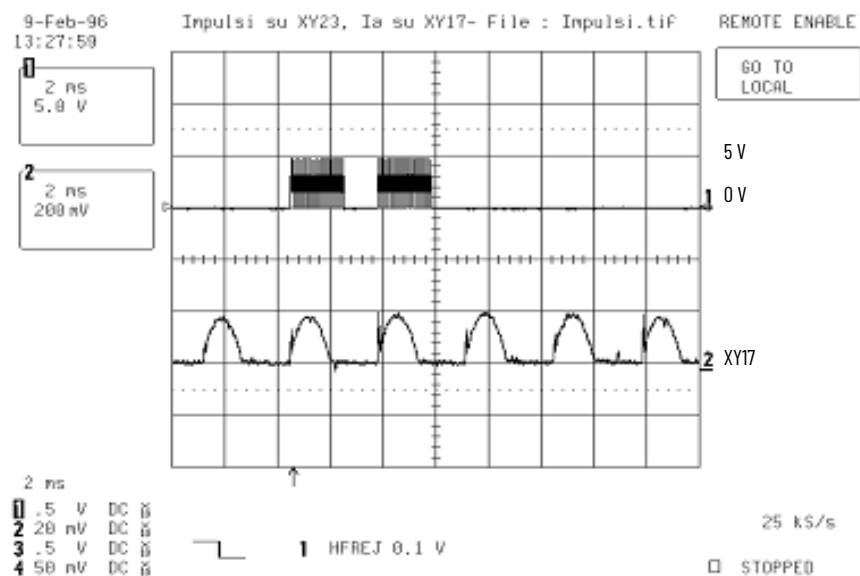
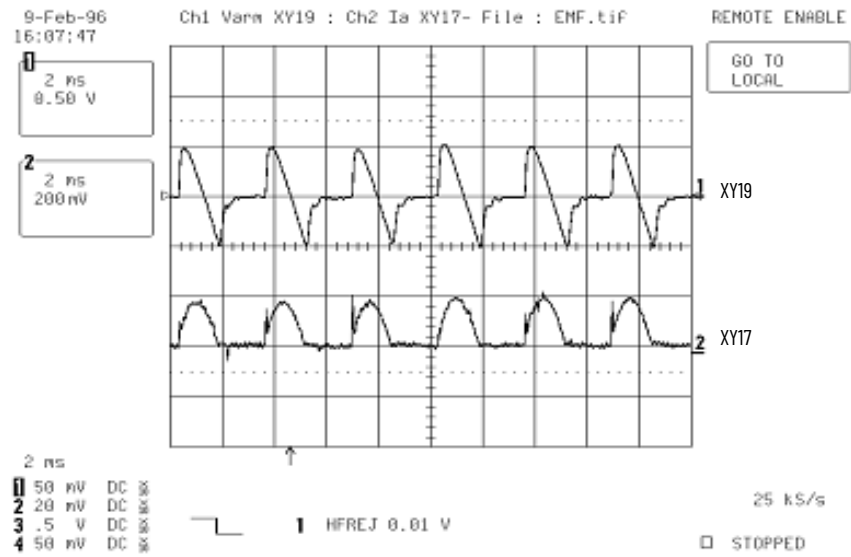

Figure 7 - Good SCR Armature Voltage and Motor Current Signal Example



A malfunctioning thyristor is connected to the relative gate. For example, if the tested signal is at XR25 and the positive bridge is active (MP high) from the following figure you can deduce that SCR connected to gate G6 is open.

Figure 8 - Open Thyristor Example

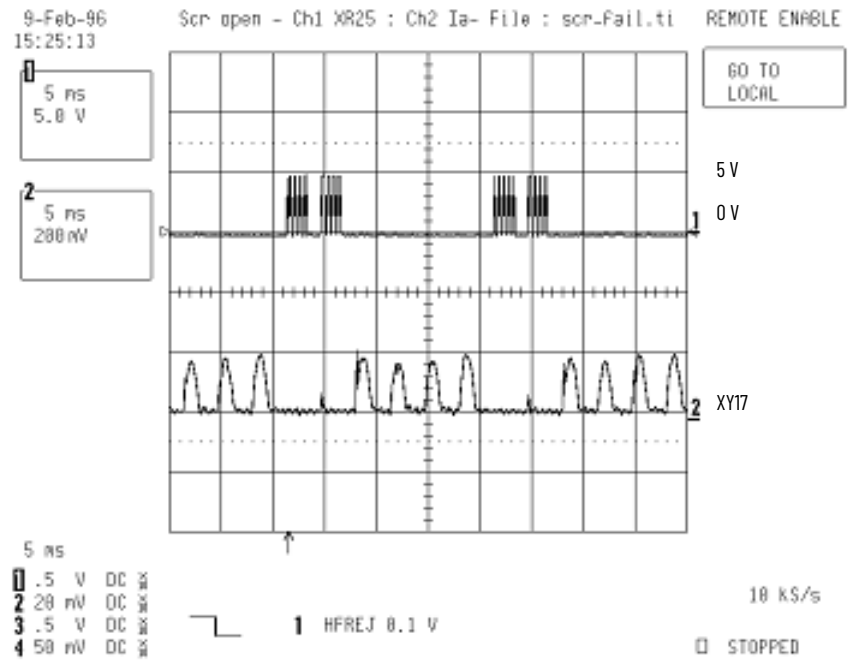

Figure 9 - Good SCR Gate Pulse and Armature Current Signals Series B Example

9-FEB-96  
16:07:47

Impulsi su XY23, Ia su XY17 - File: Impulsi: tif

REMOTE  
ENABLE

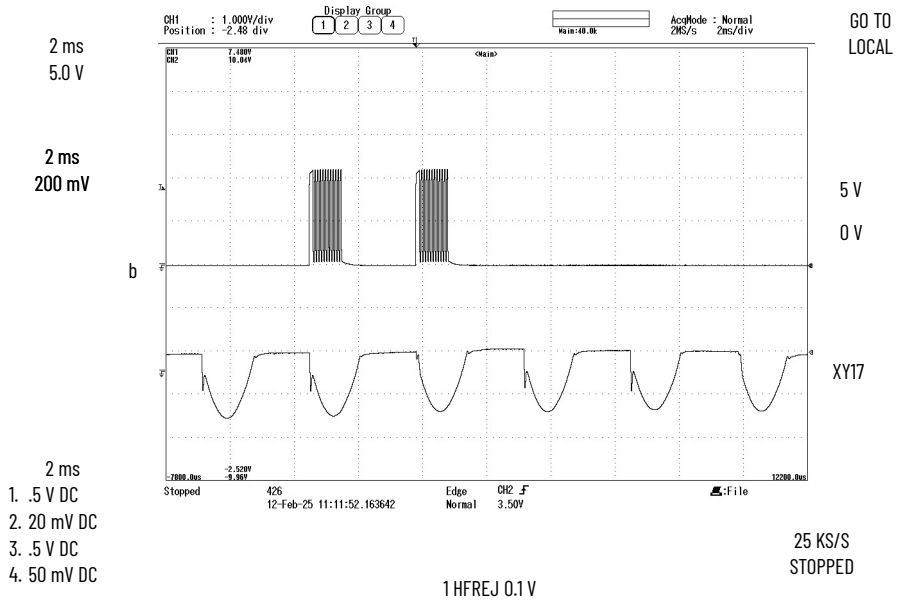

Figure 10 - Good SCR Armature Voltage and Motor Current Signal Series B Example

9-FEB-96  
16:07:47

Chi Varm XY19 : Ch2 Ia XY17 - File: EMF : tif

REMOTE  
ENABLE

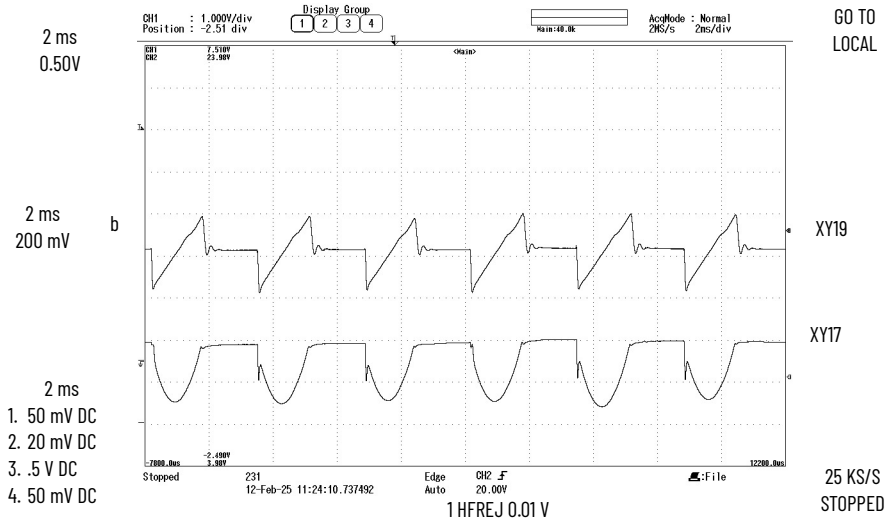

Figure 11 - Open Thyristor Series B Example

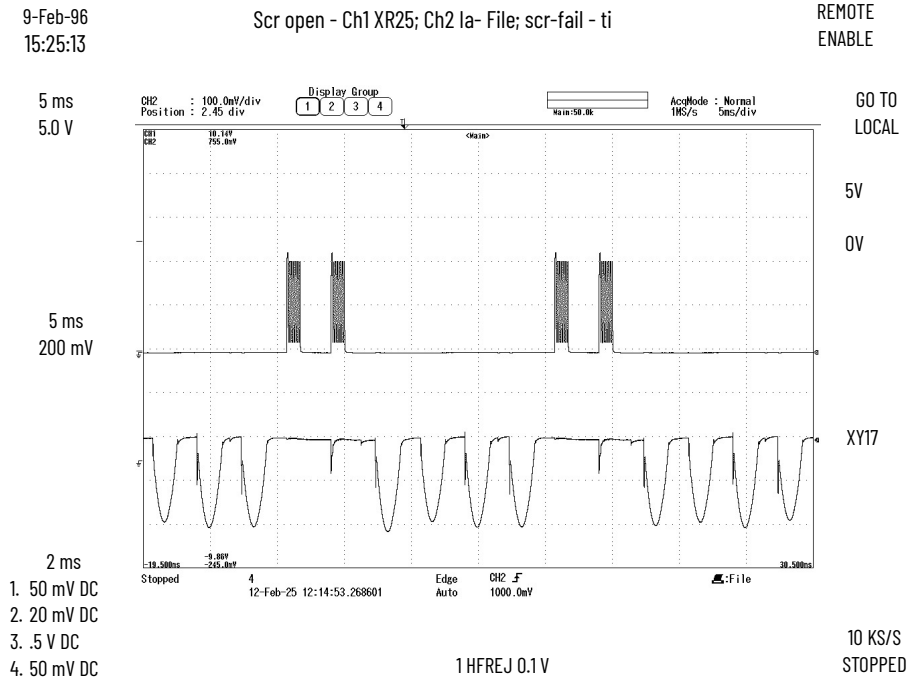

Figure 9, Figure 10 on page 27, and Figure 11 on page 28 are examples of gate pulse, current, and voltage signal measurements taken on an SCR. In these figures:

- The current signal is taken on the testpoint XY17 (+2.53V offset; -0.6V=Drive size current).
- The voltage signal is taken on the testpoint XY19 (+1.5V offset, inverted traces).
- The ground signal is taken on either testpoint XY10 or XY18.

## Troubleshoot a Field Current Loss Fault

If the drive faults with a “Field Current Loss” fault (F6) and there is low or incorrect field current present at the motor, as seen in parameter 351 [Field Current], complete the steps in Low or Incorrect Field Current. If the drive faults with a “Field Current Loss” fault (F6) and there is no field current present at the motor, as seen in parameter 351 [Field Current], complete the steps in No Field Current on page 31.

### Low or Incorrect Field Current

Note: For a flow chart version of these steps, see Low or Incorrect Field Current on page 140.

1. Read the General Safety Precautions on page 10.
2. Verify the actual value of parameter 351 [Field Current] by measuring the DC motor field current using a DC clamp.
3. Verify that the drive rated field bridge current is set correctly in parameter 374 [Drv Fld Brdg Cur] and DIP switch S14 is configured to correctly (according to the instructions in the PowerFlex Digital DC Drive User Manual, publication 20P-UM001) and make any necessary corrections. See Control Board on page 132 for DIP switch location.
4. Verify that the value of parameter 280 [Nom Mtr Fld Amps] matches the rated field current value on motor nameplate and make any necessary corrections.
5. Remove the bottom control panel and I/O and control terminal covers from the drive. See Protective Cover Removal and Installation on page 51.
6. Measure the field current signal on the green LA-LB terminal located on the control board: LA is the ground and LB is field current signal. The measured value of the field current at LA-LB should be equal to the value of parameter 374 [Drv Fld Brdg Cur]. If these values are equivalent, the voltage across these terminals should be 1.66 VDC.

Note: For lower field current values, the voltage will be proportional.

For example, if the field is set up for 2 A and the motor is rated for 1.5 A, the measurement at LA-LB will be 1.245 VDC ( $1.5 / x = 2 / 1.66$ ).

- If the voltage measurement is incorrect, continue with step 7 below.
  - If the voltage measurement is correct, but the “Field Current Loss” fault still exists, replace the control board.
7. Using an ohmmeter, measure the resistance across terminals LA-LB to verify that the value equals the equivalent resistance as indicated in the table below (set with DIP switch S14 on the control board).

Field Current Scale	S14-1	S14-2	S14-3	S14-4	S14-5	S14-6	S14-7	S14-8	Equivalent Resistance
<b>Frame D drives with a rated field supply of 40 A</b>									
1 A	OFF	OFF	OFF	OFF	OFF	OFF	ON	Not used (OFF)	3333 Ω
2 A	OFF	OFF	OFF	OFF	OFF	ON	OFF		1668 Ω
4 A	OFF	OFF	OFF	OFF	ON	OFF	OFF		845 Ω
6 A	OFF	OFF	OFF	OFF	ON	ON	OFF		560.9 Ω
10 A	OFF	ON	OFF	OFF	OFF	OFF	OFF		333.3 Ω
20 A	ON	OFF	OFF	OFF	OFF	OFF	OFF		168.5 Ω
30 A	ON	ON	OFF	OFF	OFF	OFF	OFF		111.9 Ω
40 A	ON	OFF	ON	OFF	OFF	ON	OFF		83.1 Ω

**Frame D drives with a rated field supply of 70 A**

Field Current Scale	S14-1	S14-2	S14-3	S14-4	S14-5	S14-6	S14-7	S14-8	Equivalent Resistance
1 A	OFF	OFF	OFF	OFF	OFF	ON	OFF	Not used (OFF)	1668 Ω
5 A	OFF	ON	OFF	OFF	OFF	OFF	OFF		333.3 Ω
10 A	ON	OFF	OFF	OFF	OFF	OFF	OFF		168.5 Ω
20 A	ON	OFF	ON	OFF	OFF	ON	OFF		83.1 Ω
50 A	OFF	ON	OFF	ON	OFF	OFF	OFF		32.8 Ω
70 A	ON	ON	ON	ON	OFF	OFF	OFF		23.9 Ω

If the resistance measurement is incorrect, replace the field board.

## No Field Current

Note: For a flow chart version of these steps, see No Field Current on page [139](#).

1. Read the General Safety Precautions on page [10](#).
2. Remove the top control panel cover from the drive. See Protective Cover Removal and Installation on page [51](#).
3. Verify that the correct AC voltage is present at terminals U1 and V1 at the top of the field fuse holder mounted on the control panel. See [Figure 23](#) on page [122](#) for a schematic diagram.
  - If the voltage is correct, continue with step 4 below.
  - If the voltage is incorrect or missing, remove power from the drive and verify the wiring to the drive and the power supply source and correct any problems. Test the voltage level again to verify that it is correct. If the voltage is correct, but the fault persists or parameter 351 [Field Current] is incorrect, continue with step 4 below.
4. Remove AC power to the drive and check the fuses at FU1 and FV1.
  - If the fuses are blown, complete the steps in Test Field Wiring and Voltage Signals on page [31](#).
  - If the fuses are not blown, complete the steps in Test Field Control Signals on page [31](#).

### *Test Field Wiring and Voltage Signals*

1. Test the resistance of the motor field wiring and motor field for possible short circuits.
  - If there are no short circuits, continue with step 2 below.
  - If a short circuit exists, correct any problems.
2. Check the field SCR/dual diode module for a short circuit condition. See Check the Field SCR/Dual Diode Module on page [38](#).
  - If there are no short circuits, continue with step 3 below.
  - If a short circuit exists, replace the field SCR/dual diode module.
3. Replace the field fuses at FU1 and FV1 and apply power to the drive.
4. If the field fuses blow, replace the field board.

### *Test Field Control Signals*

1. Disconnect the cable from connector XR on the control board and measure the U1-V1 voltage synchronization signal at pin 11 on the cable. See [Figure 36](#) on page [132](#) for location of the XR connector on the control board.

This signal is a square wave signal with a 90° lag phase displacement compared to the AC voltage signal.

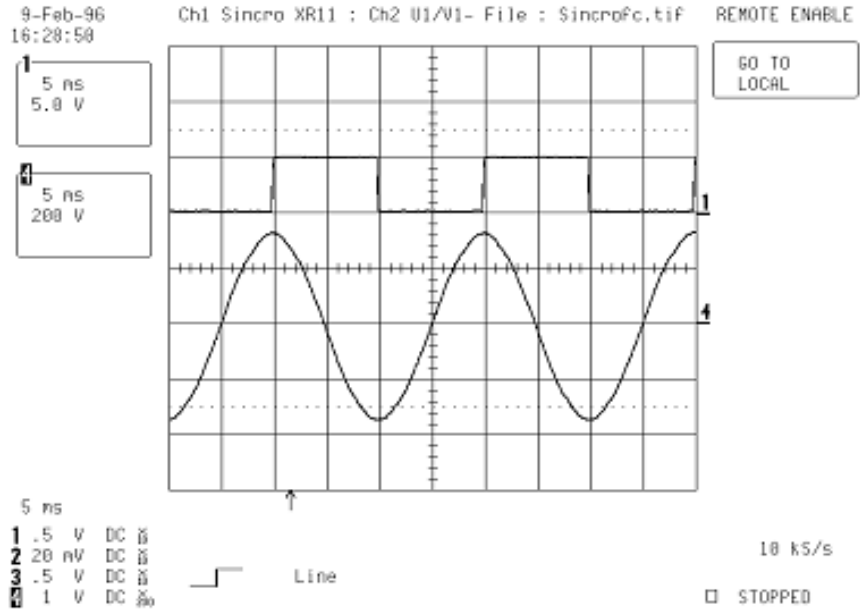

2. Measure the gate signals at pins XR-1 and XR-2 on the cable. The figure below displays the following signals from top to bottom:

Channel	Signal
1	U1-V1 Sync
4	Ie - LEM current feedback signal taken on LA-LB terminal
2	ITF1 pulse
3	ITF2 pulse

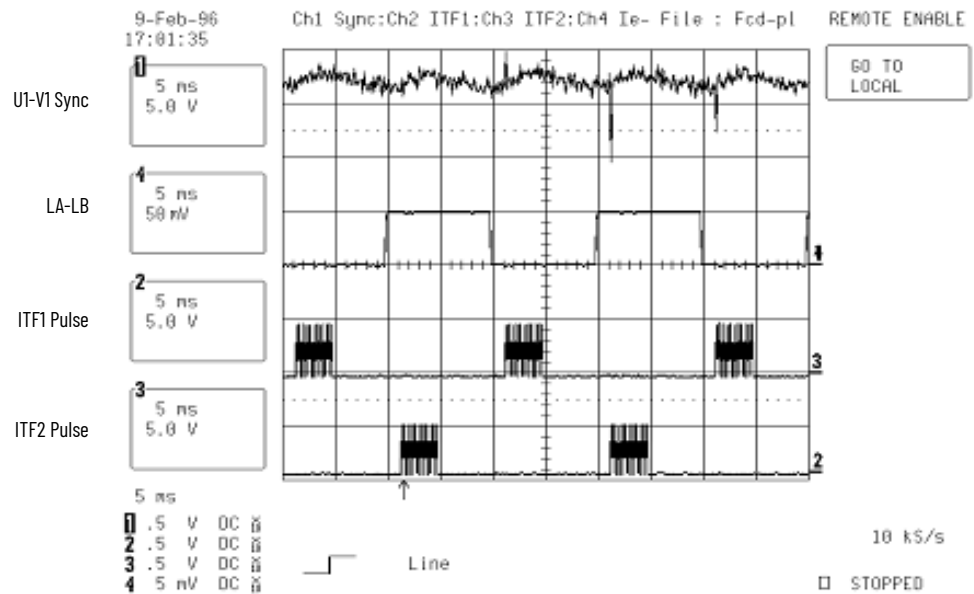

- If the gate signals are missing, replace the control board.
- If the gate signals are present, replace the field board.

## Power Component Test Procedures

### Check the Armature SCR Modules

The frame D TPDflex DC Converter armature supply consists of three (non-regenerative drives) or six (regenerative drives) SCR modules mounted on heat sinks within the leg assemblies. A malfunction of any of these devices will be indicated by either an Overcurrent fault (F13), blown or tripped incoming protection devices, or erratic motor operation. The following procedure can be used if an armature bridge component malfunction is suspected.

1. Read the General Safety Precautions on page [10](#).
2. Remove power from the drive. See Remove Power from the Drive on page [48](#).
3. Open the control panel. See Open the Control Panel on page [53](#).
4. Verify that power to an external field supply (if used) is removed.
5. Check the anode to cathode junction of each SCR. With a digital multimeter set to Ohms, measure the resistance across the SCRs (lead orientation is not critical). Measurements must be taken below the AC input leg fuses on the U, V, and W phases for the specific SCR module.

For regenerative drives, see [Table 3](#) on page [34](#) and [Figure 12](#) on page [34](#). For non-regenerative drives, see [Table 4](#) on page [35](#) and [Figure 13](#) on page [35](#).

If a low resistance is detected, determine which SCR module(s) is/are damaged based on the tables below and replace that module(s). See SCR Module Leg Assembly Removal and Installation on page [99](#).

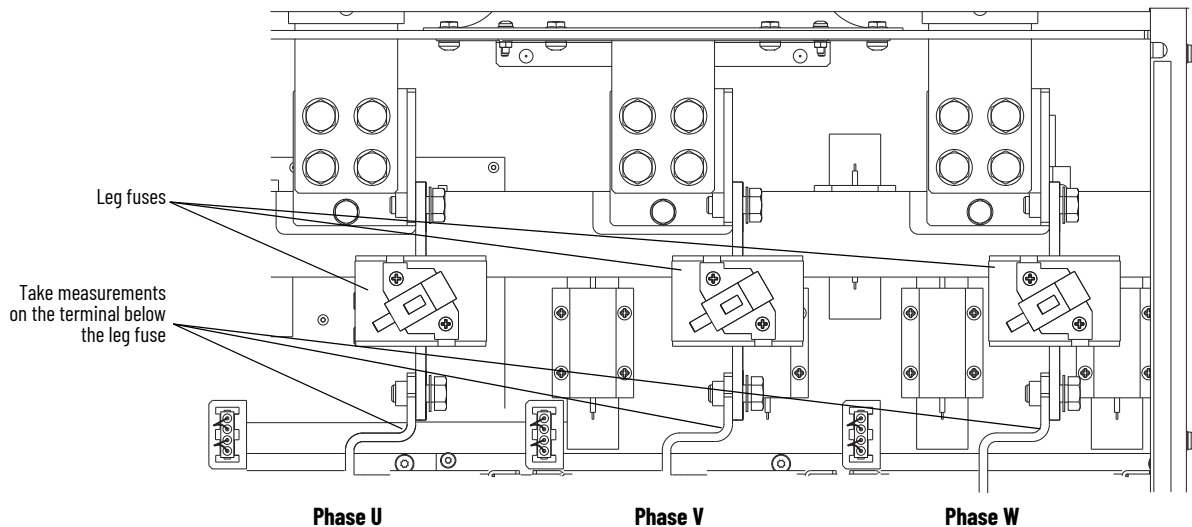

**Table 3 - SCR Anode to Cathode Junction Measurements for Regenerative Drives**

For SCR...	Measure from Terminal...	To Terminal...	Nominal meter reading:
1	U	C	"open circuit" or "megaOhms" range
4	U	D	
2	V	C	
5	V	D	
3	W	C	
6	W	D	
01	U	C	
04	U	D	
02	V	C	
05	V	D	
03	W	C	
06	W	D	

**Figure 12 - Regenerative Drive SCR Module Layout**

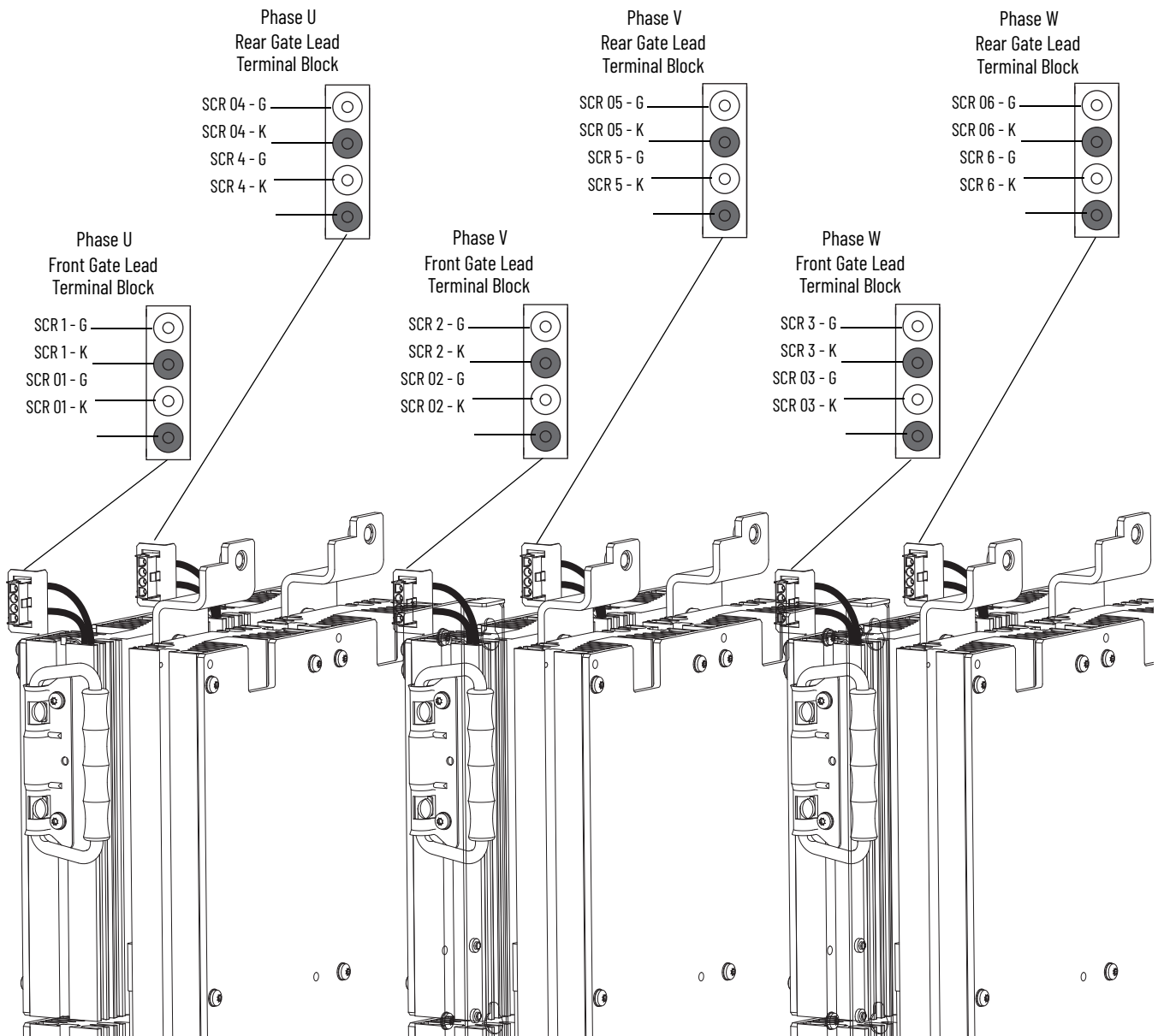

**Table 4 - SCR Anode to Cathode Junction Measurements for Non-Regenerative Drives**

For SCR...	Measure from Terminal...	To Terminal...	Nominal meter reading:
1	U	C	"open circuit" or "megaohms" range
4	U	D	
2	V	C	
5	V	D	
3	W	C	
6	W	D	

**Figure 13 - Non-Regenerative Drive SCR Module Layout**

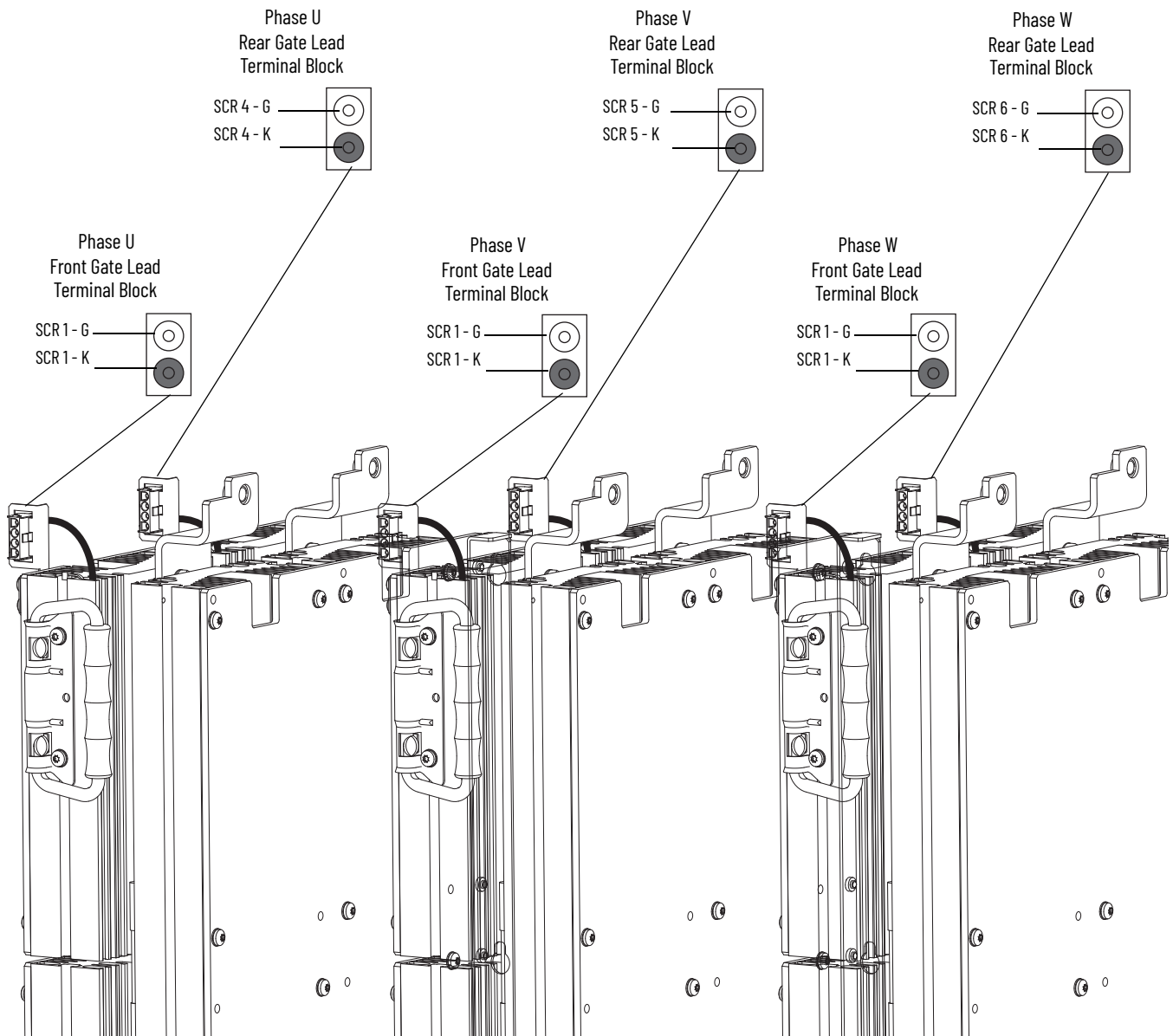

- Disconnect the gate lead connectors from the terminal blocks at the top of each phase leg assembly. With a digital multimeter set to Ohms, measure the resistance of each SCR junction using the pins on the terminal block as identified in the table below.

For regenerative drives, see [Table 5](#) below and [Figure 12](#) on page [34](#). For non-regenerative drives, see [Table 6](#) below and [Figure 13](#) on page [35](#).

If a measurement is outside of the range specified in the tables below or if one reading deviates significantly from the majority, then module replacement may be necessary. See SCR Module Leg Assembly Removal and Installation on page [99](#).

**Table 5 - SCR Gate to Cathode Junction measurements for Regenerative Drives**

SCR...	Measure from ...	To...	Nominal meter reading:
1	Pin G	Pin K	5...30 Ω <sup>(1)</sup>
4	Pin G	Pin K	
2	Pin G	Pin K	
5	Pin G	Pin K	
3	Pin G	Pin K	
6	Pin G	Pin K	
01	Pin G	Pin K	
04	Pin G	Pin K	
02	Pin G	Pin K	
05	Pin G	Pin K	
03	Pin G	Pin K	
06	Pin G	Pin K	

(1) The actual reading varies depending upon the SCR manufacturer. Verify that the actual measured value is consistent for all SCRs.

**Table 6 - SCR Gate to Cathode Junction Measurements for Non-Regenerative Drives**

SCR...	Measure from ...	To...	Nominal meter reading:
1	Pin G	Pin K	5...30 Ω <sup>(1)</sup>
4	Pin G	Pin K	
2	Pin G	Pin K	
5	Pin G	Pin K	
3	Pin G	Pin K	
6	Pin G	Pin K	

(1) The actual reading varies depending upon the SCR manufacturer. Verify that the actual measured value is consistent for all SCRs.

## Check the Pulse Transformer Board

The armature pulse transformer circuit board contains an isolated gate firing circuit and also provides dv/dt protection for the armature SCR modules. A malfunction of these devices will be indicated by either an Overcurrent fault (F13), blown or tripped incoming protection devices or erratic motor operation. Use the following procedure if a malfunction in this circuitry is suspected.

1. Read the General Safety Precautions on page [10](#).
2. Remove power from the drive. See Remove Power from the Drive on page [48](#).
3. Remove the pulse transformer board. See Pulse Transformer Circuit Board Removal and Installation on page [71](#).
4. With a digital multimeter set for a "continuity check", measure each connection point on the pulse transformer board listed in the tables below. See [Figure 34](#) on page [128](#) for connector locations. If any of the actual measurements are out of tolerance, replace the Pulse Transformer board.

**Table 7 - Armature Pulse/Snubber Circuit Measurements for Regenerative Drives**

For SCR	Measure From ...	To ...	Meter reading:	Connector XY Pinout
1	KG1	XY-4	"open circuit"	
4	KG4	XY-1		
2	KG2	XY-5		
5	KG5	XY-2		
3	KG3	XY-6		
6	KG6	XY-3		
01	KG01	XY-1		
04	KG04	XY-4		
02	KG02	XY-2		
05	KG05	XY-5		
03	KG03	XY-3		
06	KG06	XY-6		

**Table 8 - Armature Pulse/Snubber Circuit Measurements for Non-Regenerative Drives**

For SCR	Measure From ...	To ...	Meter reading:	Connector XY Pinout
1	KG1	XY-1	"open circuit"	
4	KG4	XY-4		
2	KG2	XY-2		
5	KG5	XY-5		
3	KG3	XY-3		
6	KG6	XY-6		

- With the digital multimeter set to “diode test”, measure each connection point on the pulse transformer board listed in the tables below. If any of the actual measurements are out of tolerance, replace the Pulse Transformer board.

**Table 9 - Armature Pulse Transformer Primary Measurements for Regenerative and Non-Regenerative Drives**

For SCR	(+) Meter Lead	(-) Meter Lead	Meter reading:	Connector XY Pinout
1/01	XY-8	XY-1	0.41 Ω	
4/04	XY-8	XY-4		
2/02	XY-8	XY-2		
5/05	XY-8	XY-5		
3/03	XY-8	XY-3		
6/06	XY-8	XY-6		

**Table 10 - Armature Pulse Transformer Primary Measurements for Regenerative Drives**

For SCR	(+) Meter Lead	(-) Meter Lead	Meter reading:	Connector XY Pinout
1	XY-7	XY-1	0.41 Ω	
4	XY-7	XY-4		
2	XY-7	XY-2		
5	XY-7	XY-5		
3	XY-7	XY-3		
6	XY-7	XY-6		

### Check the Field SCR/Dual Diode Module

The field supply consists of a dual pack SCR/dual diode module arranged in a single-phase full wave rectifier configuration. Malfunction of either of these components may cause various responses including field and velocity related faults, or blown fuses. The following procedures can be used if field bridge malfunctions are suspected.

- Read the General Safety Precautions on page [10](#).
- Remove power from the drive. See Remove Power from the Drive on page [48](#).
- Remove the top and bottom control panel and I/O and control terminal covers. See Protective Cover Removal and Installation on page [51](#).
- Verify that contactor power (if used) is removed.
- Verify that power to an external field supply (if used) is removed.
- Disconnect the field wires from C1 and D1. See Bottom, Left Side of Drive in [Figure 14 on page 40](#).

7. Check the anode to cathode junction of the field SCR/dual diode module. With the digital multimeter set to “diode test”, measure the resistance across the modules. See [Table 11](#) below and [Figure 14](#) on page [40](#).

If a low resistance is detected, replace the modules. See Field SCR and Dual Diode Module Removal and Installation on page [76](#).

If a measurement results in an “infinity” reading, check the fuses at FU1 and FV1 on the control panel to determine if they are open. See [Figure 14](#) on page [40](#).

**Table 11 - SCR/Dual Diode Module Anode to Cathode Junction Measurements**

(+) Meter Lead Terminal	(-) Meter Lead Terminal	Nominal meter reading:
U1	C1	0.45V
U1	D1	open or infinity
V1	C1	open or infinity
V1	D1	open or infinity
C1	D1	open or infinity
C1	U1	open or infinity
C1	V1	open or infinity
D1	C1	0.9V
D1	U1	0.45V
D1	V1	open or infinity

Figure 14 - Field Terminal Block and Field Fuse Locations



8. Remove the cable from connector XP on the pulse transformer circuit board.
9. Check the gate cathode junction of the field SCR/dual diode module. With the digital multimeter set to "diode test" measure the resistance across the modules (lead orientation is not critical). See [Table 12](#).  
If a low resistance is detected, replace the SCR/dual diode module.

Table 12 - SCR/Dual Diode Module Gate Cathode Junction Measurements

Measure from...	To...	Nominal meter reading:
XP1	XP2	10...20 Ω
XP3	XP4	

## Speed Feedback Device Tests

### Check the Encoder

The encoder feedback device provides a dual channel quadrature output waveform and requires that the output be differential line drivers at +5 or +12...15V signal levels. The encoder power supply voltage and input selection is controlled by DIP switch S21 on the control board (see "DIP Switch and Jumper Settings" in the TPDflex DC Converters User Manual, publication 1S7TFLEXUM0). The encoder power supply from the drive can be measured from +V (+) to COM (-) with a digital multimeter. If S21 is set to ENC\_5, the voltage level should be

+2.5...5.4V. If S21 is set to ENC\_12, the voltage level should be +5.4V...15.2V. For reference, see [Figure 26](#) on page [123](#) for a schematic diagram.

The Channel A and Channel B are square wave type outputs that are 90 degrees out of phase. When rotating in the CCW direction, as viewed from the commutator end, Channel A leads Channel B. Each differential channel has an inverted and non-inverted signal.

Power for the encoder is provided internally and is capable of 200mA of current with a current foldback feature that protects the power supply should the current draw exceed 200mA. If different power supply requirements exist for the chosen feedback device, the supply must be provided external to the drive.

The frequency is proportional to speed and the pulse rate of the encoder, referred to as the "Pulse/Rev" rating on the nameplate. The speed of the motor can be calculated by: Speed (RPM) = [Frequency (Hz) x 60] / [Pulses/Revolution].

## Check the DC Tachometer

- Verify that DIP switch S4 on the control board is set to the correct input voltage of the DC analog tachometer. See "DIP Switch and Jumper Settings" in the PowerFlex Digital DC Drive User Manual, publication 20P-UM001. Also, see [Figure 27](#) on page [124](#) for a circuit diagram.
- The analog tach signal is fine scaled using parameter 562 [Anlg Tach Gain].
- See "Drive Reference and Feedback Scaling" in Appendix C of the PowerFlex Digital DC Drive User Manual, publication 20P-UM001, for more information.

## Check the Resolver Interface Board

The resolver feedback option module uses the resolver feedback board for resolver connections, and the resolver interface board for external power, status, feedback board reset, and encoder output connections.

If a “Resolver Error” (F93) fault occurs and the resolver wiring and configuration are correct, the following LED indicators and testpoints on the resolver interface board can be used to verify that the board is not damaged.

- Verify that the following LEDs are functioning as expected. See [Figure 15](#) on page [43](#) for LED locations and switch settings.

LED Code	LED Color	On State	Off State
D3	Red	24V overload (fuse F1 blown). This fuse is self-resetting when it returns to normal operating temperature.	24V supply is OK.
D10	Green	12V supply is OK.	Loss of 12V power.
D11	Green	Resolver feedback board voltage is OK.	Voltage error on resolver feedback board.
D12	Blue	Switch S1 is set to +24V for encoder signal output on TB2.	S1 is <u>not</u> set for +24V.
D16	Yellow	Switch S1 is set to +12V for encoder signal output on TB2.	S1 is <u>not</u> set for +12V.
D18	Green	Switch S1 is set to +5V for encoder signal output on TB2.	S1 is <u>not</u> set for +5V.
D26	Red	Resolver feedback board is in reset mode.	Resolver feedback board <u>not</u> in reset mode.

If any of the LEDs that should turn on when control power is applied fail to do so, verify that the resolver interface and resolver feedback boards are properly seated on the appropriate connectors (XRE, P2, P3). If problems persist, replace the resolver interface and/or resolver feedback board.

- Measure the signal voltage at the testpoints as indicated in the following table. See [Figure 15](#) on page [43](#) for testpoint locations.

Testpoint	to	Testpoint	Measurement
+12V	...	OV12	12V DC $\pm 5\%$
-12V	...	OV12	-12V DC $\pm 5\%$
+24V_VI	...	OV24	24V DC $\pm 5\%$
+5V	...	OV5	5V DC $\pm 5\%$

If any of the voltage measurements fails, replace the resolver interface board.

Figure 15 - Resolver Interface Board Testpoint Locations

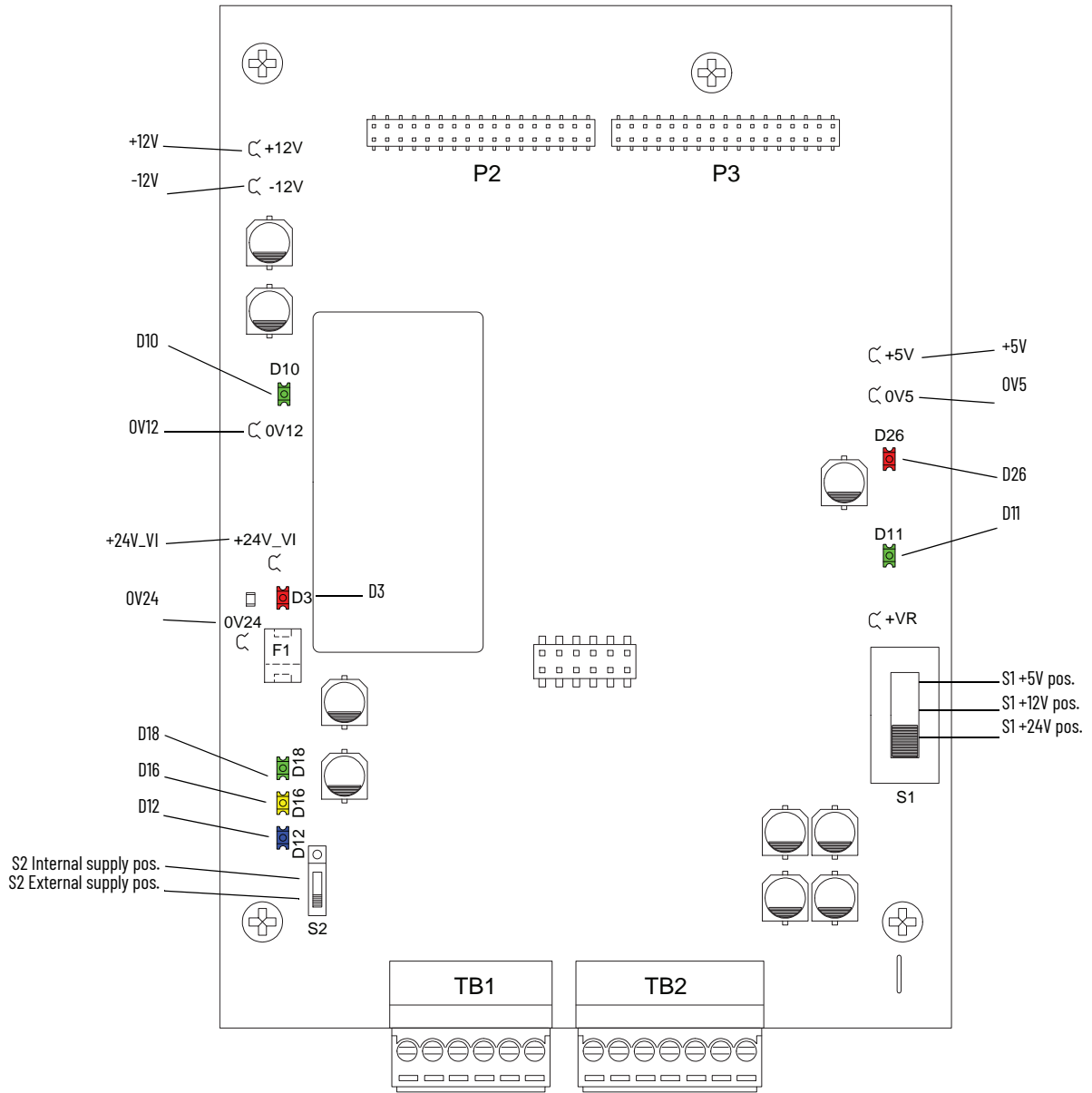

## Thermistors and Thermal Switches

Motor overheating is detected by an external, user-supplied thermistor (PTC) or thermal switch connected to terminals 78 and 79 on the control power terminal block on the lower, right corner of the pulse transformer circuit board. See [Figure 34](#) on page [128](#) for terminal block location.

Motor overheating is typically identified by a “Motor Over Temp” fault (F16). See “Fault Descriptions” in Chapter 4 of the TPDFlex DC Converters User Manual, publication 1S7TFLEXUM0 for details. See [Figure 28](#) on page [124](#) for a circuit diagram.

- If a thermal switch is used, a 1 k $\Omega$  resistor must be placed in series between the switch and either terminal 78 or 79.
- If neither a thermistor (PTC) or a thermal switch is installed, a 1 k $\Omega$  resistor must be connected between terminals 78 and 79.

The drive heatsink temperature is monitored by a bimetal thermostat connected directly to the heatsink. When the heatsink temperature is too high, a “Heatsink OvrTemp” fault (F8) occurs. See “Fault Descriptions” in Chapter 4 of the PowerFlex Digital DC Drive User Manual, publication 20P-UM001 for details. See [Figure 29](#) on page [125](#) for a circuit diagram.

During normal operation, 1.6V DC is present between terminal 78 and drive common. When an open circuit exists between terminals 78 and 79, 24V DC will be present at terminal 78 to drive common. If the 24V is missing, the pulse transformer board may need replacement.

## Relay Outputs

Terminals 35 and 36 and 75 and 76 are N.O. relay outputs. The relay output between terminals 35 and 36 is configured with parameter 1392 [Relay Out 1 Sel]. The relay output between terminals 75 and 76 is configured with parameter 629 [Relay Out 2 Sel]. See “Using Contactors” in Chapter 1 of the TPDFlex DC Converters User Manual, publication 1S7TFLEXUM0, publication for more information.

The “Main Contactor” fault (F10) indicates a problems related to a contactor used with the drive. See “Fault Descriptions” in Chapter 4 of the TPDFlex DC Converters User Manual, publication 1S7TFLEXUM0 for details.

## Create a Fault Report

Complete fault reports are critical for analysis and repair of modules returned to the factory.

At a minimum, perform and record the following:

- Record the contents of the fault queue (faults and times of occurrence). See the PowerFlex Digital DC Drive User Manual, publication 1S7TFLEXUM0, for detailed Fault and Alarm codes and descriptions.
- Make a record of any burn marks on the printed circuit boards, cabling, bus bars, and SCR modules
- Make a record of any liquid and condensation marks on the printed circuit boards, components and mechanical parts
- Make a record of the amount of dust and other additional particles on the drive and drive components
- Make a record of any mechanical damage to the drive and drive components
- Record the size and type of main fuses
- Record any other important marks and damage

## What You Need When You Call Tech Support

When you contact Technical Support, please be prepared to provide the following information:

- Order number
- Product catalog number and drives series number (if applicable)
- Product serial number
- Firmware revision level
- Most recent fault code
- Your application

You can use the table below to record the data provided in each PowerFlex DC drive parameter listed.

Param(s)	Name	Description	Parameter Data
1349	Status1 at Fault	Captures and displays Par 381 [Drive Status 1] bit pattern at the time of the last fault.	
1350	Status2 at Fault	Captures and displays Par 382 [Drive Status 2] bit pattern at the time of the last fault.	
1351-1360	Fault x Code	A code that represents the fault that tripped the drive. The codes will appear in these parameters in the order they occur (i.e., [Fault 1 Code] = the most recent fault).	
1361-1370	Fault x Time	The time between initial drive power up and the occurrence of the associated trip fault.	
1371	Fault Arm Amps	Captures and displays the armature current (as a percentage of rated current) at the time of the last fault.	
1372	Fault Speed	Captures and displays the output speed (rpm) of the drive at the time of the last fault.	
1373	Fault Field Amps	Captures and displays the field current (as a percentage of rated current) at the time of the last fault.	
1374	Fault Voltage	Captures and displays the armature voltage at the time of the last fault.	

**Notes:**

## Access Procedures

### Introduction

This chapter provides detailed procedures for removing and replacing drive components.

Topic	Page
Remove Power from the Drive	48
Field Circuit Fuse Removal and Installation	49
DPI / HIM Assembly Removal and Installation	50
Protective Cover Removal and Installation	51
Open and Close the Control Panel	53
Communication Adapter and EMI Shield Removal and Installation	54
Switching Power Supply Fuse Removal and Installation	56
Install the new fuse in the reverse order of removal.Resolver Feedback and Interface Circuit Board Removal and Installation	58
I/O Expansion Circuit Board Removal and Installation	62
115V AC to 24V DC I/O Converter Circuit Board Removal and Installation	64
Control Circuit Board Removal and Installation	65
Switching Power Supply Circuit Board Removal and Installation	70
Pulse Transformer Circuit Board Removal and Installation	71
Field Circuit Board Removal and Installation	75
Field SCR and Dual Diode Module Removal and Installation	76
Field Fuse Holder Removal and Installation	79
Fan Starting Capacitor Removal and Installation	81
Series A Fan Circuit Board Removal and Installation	83
Series B Fan Circuit Board Removal and Installation	84
Series A Fan Assembly Removal and Installation	85
Series B Fan Assembly Removal and Installation	87
Series C Fan Assembly Removal and Installation	89
AC Current Transducers Removal and Installation	91
Overvoltage Clipping Circuit Board Fuse Removal and Installation	95
Overvoltage Clipping Circuit Board Removal and Installation	96
Armature Leg Fuse Removal and Installation	97
SCR Module Leg Assembly Removal and Installation	99
Bimetal Thermostat Removal and Installation	105
Discharge Resistors Removal and Installation	105

Topic	Page
Inrush Limiting Resistor Removal and Installation	107
Snubber Capacitors Removal and Installation	110
Snubber Resistors Removal and Installation	111

## Remove Power from the Drive



**ATTENTION:** Remove power before making or breaking cable connections. When you remove or insert a cable connector with power applied, an electric arc may occur. An electric arc can cause personal injury or property damage by:

- sending an erroneous signal to your system’s field devices, causing unintended machine motion
- causing an explosion in a hazardous environment

Electric arcing causes excessive wear to contacts on both the module and its mating connector. Worn contacts may create electrical resistance.

Remove and lockout all incoming power to the drive.

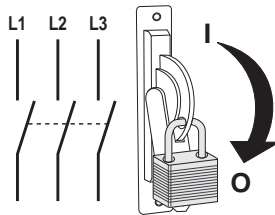

## Field Circuit Fuse Removal and Installation

### Remove the Field Circuit Fuses

1. Read the General Safety Precautions on page [10](#).
2. Remove power from the drive. See Remove Power from the Drive on page [48](#).
3. Pull down on the tabs at the top of the fuse holder on the front of the drive and remove the fuses.

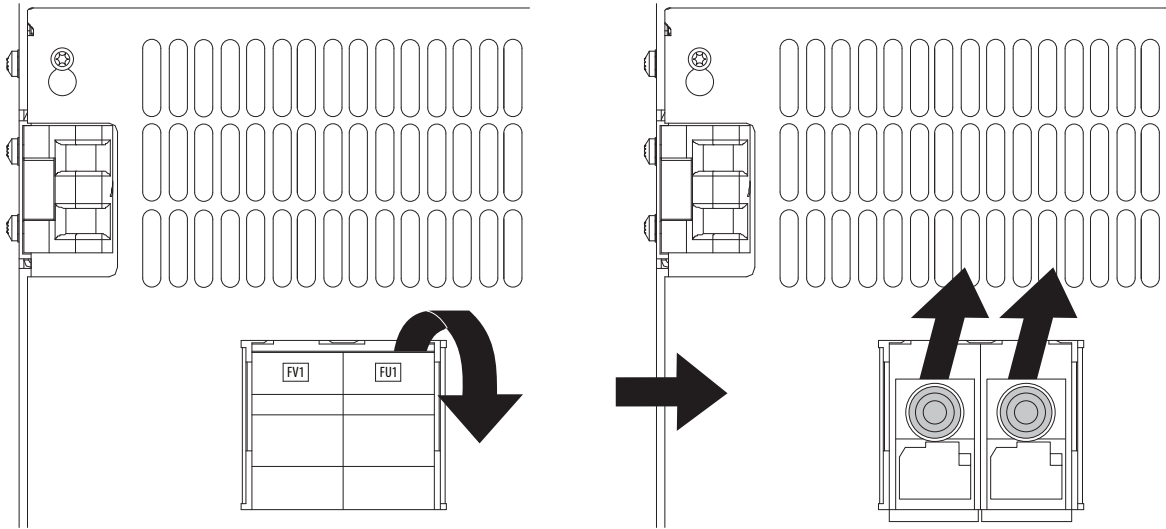

## Install the Field Circuit Fuses

Install the new field circuit fuses in reverse order of removal.

## DPI / HIM Assembly Removal and Installation

### Remove the DPI / HIM Assembly from the Protective Cover

1. Read the General Safety Precautions on page [10](#).
2. Remove power from the drive. See Remove Power from the Drive on page [48](#).
3. Disconnect the DPI cable from the HIM assembly.
4. Remove the screw that secures the DPI / HIM assembly to the drive.
5. Carefully remove the DPI / HIM assembly from the cover and disconnect the cable from the connector on the back side of the assembly.

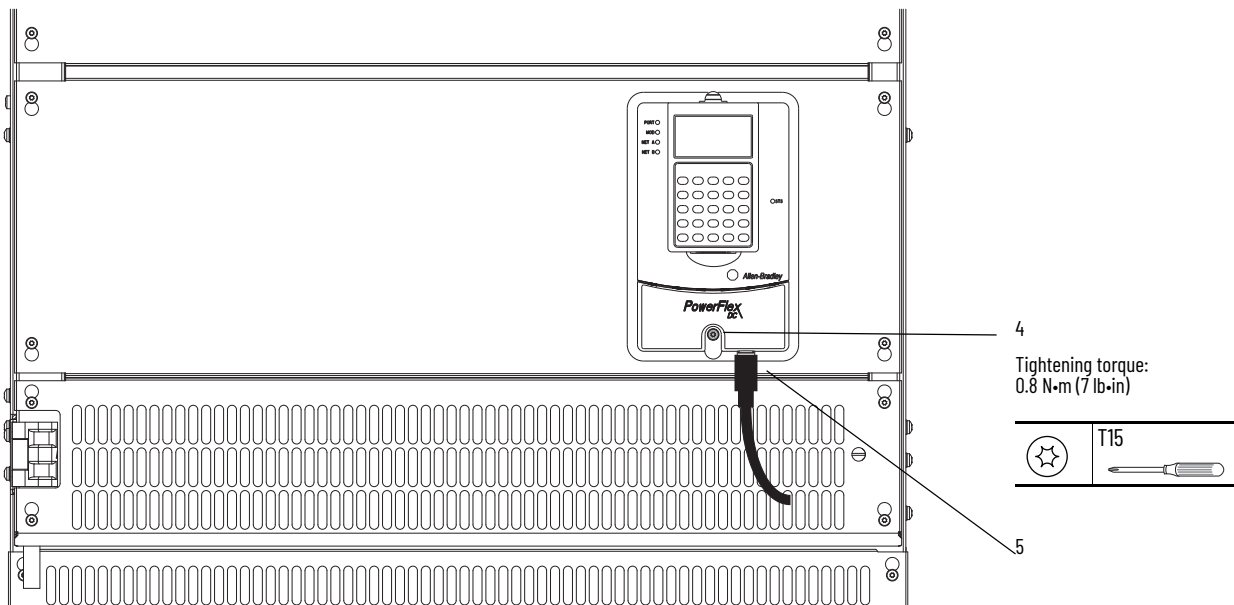

## Install the DPI / HIM Assembly on the Protective Cover

Install the DPI / HIM assembly in reverse order of removal.

## Protective Cover Removal and Installation

### Remove the Protective Covers

1. Read the General Safety Precautions on page [10](#).
2. Remove power from the drive. See Remove Power from the Drive on page [48](#).
3. If necessary, disconnect the DPI cable from the HIM (if present).

---

**IMPORTANT** The HIM is connected via a cable to the control board and therefore the bottom control panel cover cannot pull free from the drive until the cable is disconnected. The cover does, however, have notches on the side in order that it can be hung on the screws without disconnecting the HIM cable.

---

4. Loosen, but do not remove, the hexalobular screws that secure the cover to the drive chassis, slide the cover up or down, and lift the cover off the drive.

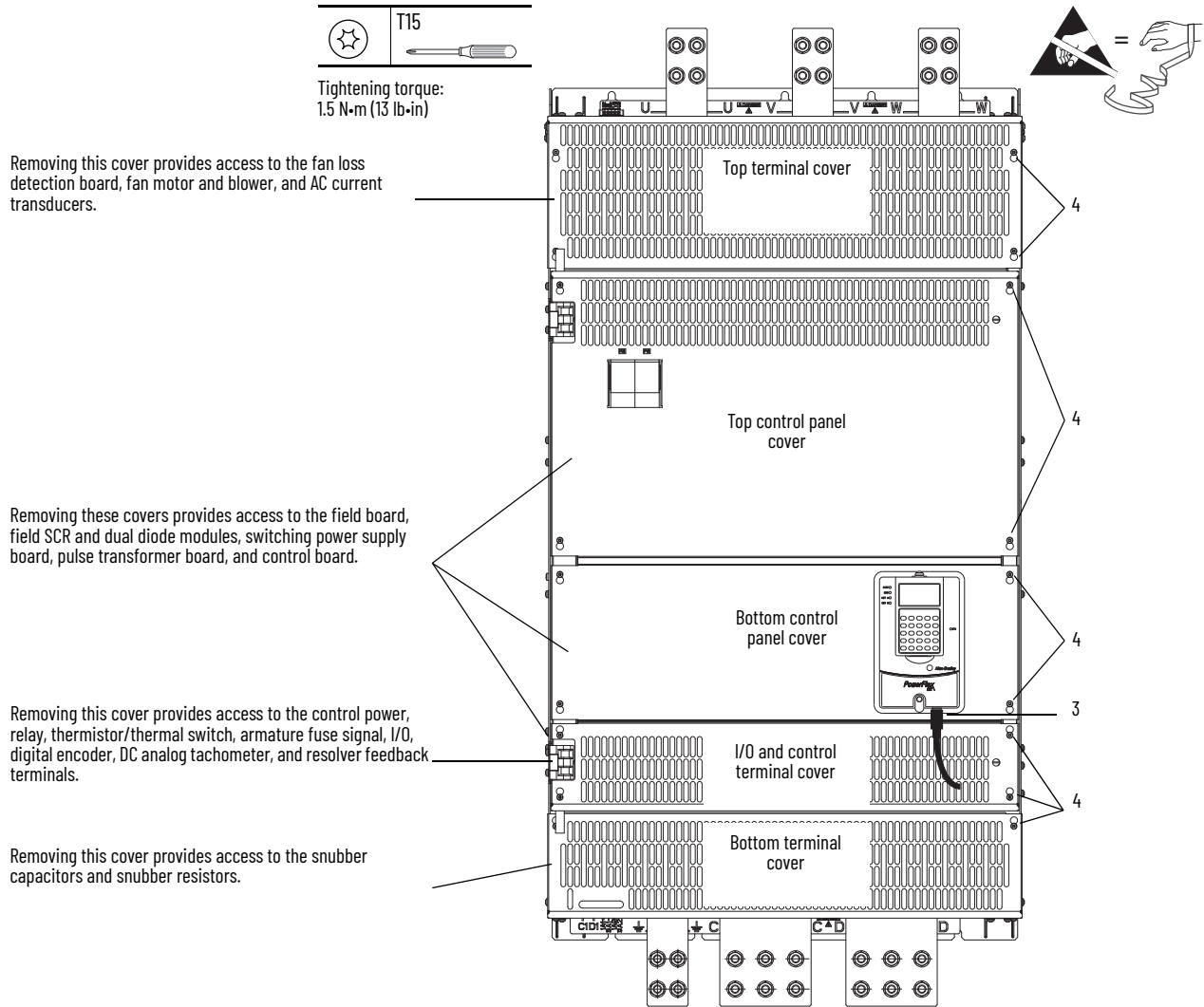

5. Disconnect the HIM communication cable from the connector on the upper right corner of the control board and remove the bottom control panel cover.

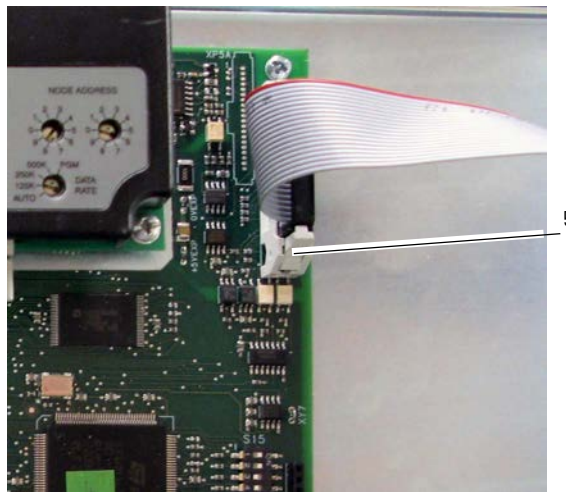

## Install the Protective Covers

Install the protective covers in reverse order of removal.



**ATTENTION:** Risk of electric shock exists when power is applied to the power terminals of the drive. The protective covers must be replaced after servicing the drive.

## Open and Close the Control Panel

### Open the Control Panel

Opening the control panel provides access to the armature leg fuses, overvoltage clipping board, SCR gate lead terminals, SCR modules, bimetal thermostat, discharge resistors, and inrush limiting resistors.

1. Read the General Safety Precautions on page [10](#).
2. Remove power from the drive. See Remove Power from the Drive on page [48](#).
3. Disconnect the DPI cable from the HIM (if present).
4. Insert a flathead screwdriver into the holes in the right side of the protective covers on the drive and turn the latch 90° counter-clockwise.
5. Open the control panel to the left.

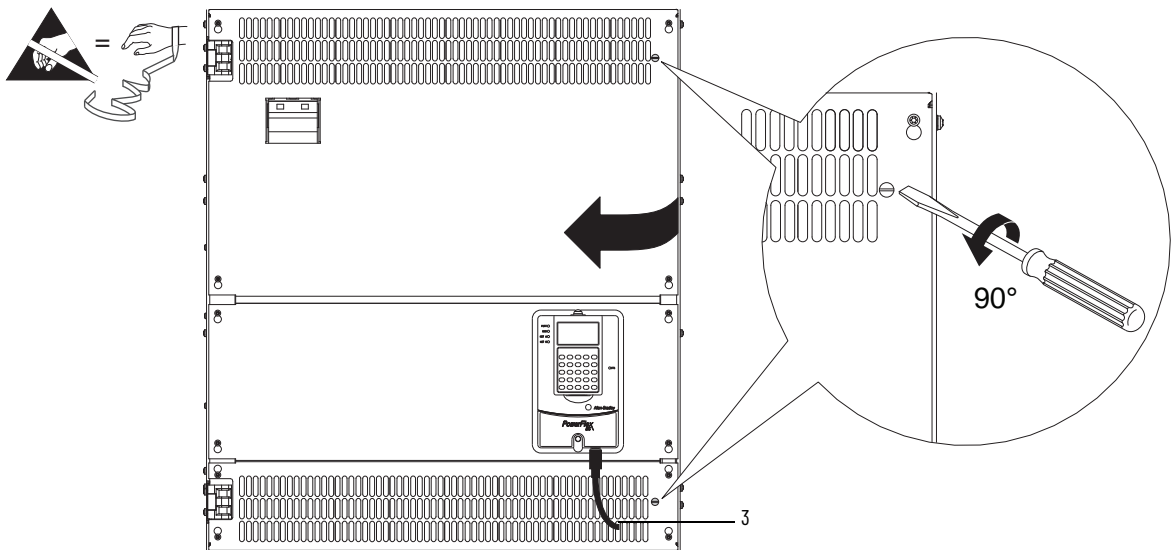

## Close the Control Panel

Close the control panel in the reverse order.

## Communication Adapter and EMI Shield Removal and Installation

### Remove the Communication Adapter and EMI Shield

1. Read the General Safety Precautions on page [10](#).
2. Remove power from the drive. See Remove Power from the Drive on page [48](#).
3. Remove the bottom control panel cover. See Remove the Protective Covers on page [51](#).
4. Disconnect the interface cable from the communication adapter and set it aside.
5. Disconnect any network cables from the adapter and set them aside.

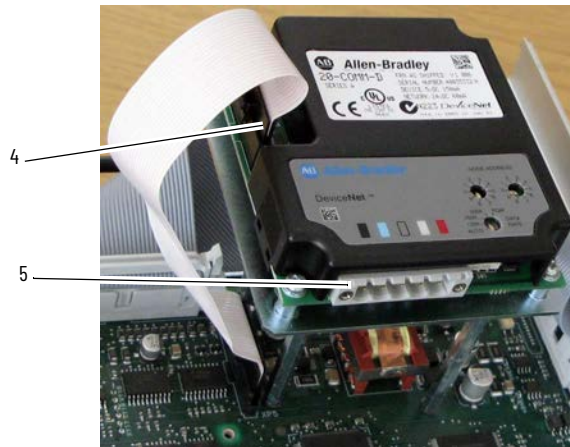

Note: Frame A shown.

6. Remove the four screws that secure the communication adapter to the EMI shield and remove the adapter.

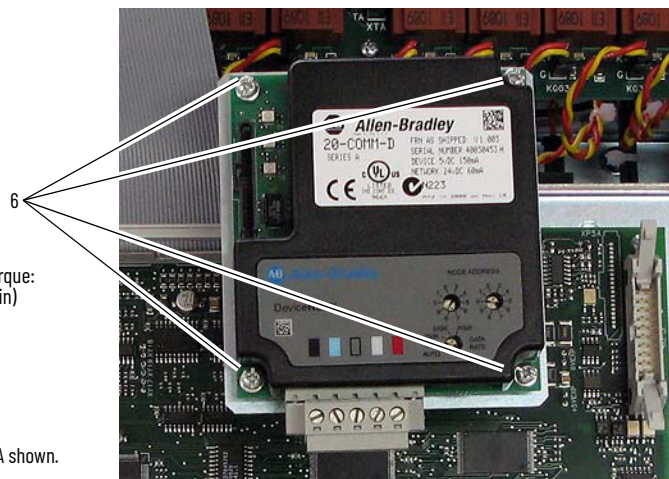

Tightening torque:  
0.9 N·m (8 lb·in)

Note: Frame A shown.

- Remove the three screws that secure the EMI shield to the stand-offs on the control board and remove the EMI shield.

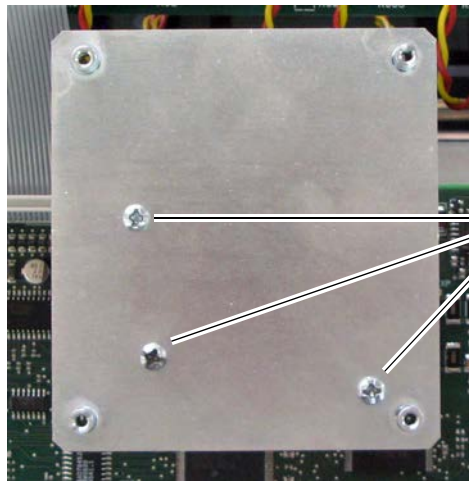

Tightening torque:  
1.0 N·m (8.9 lb·in)

Note: Frame A shown.

- Remove the three stand-offs from the control board.

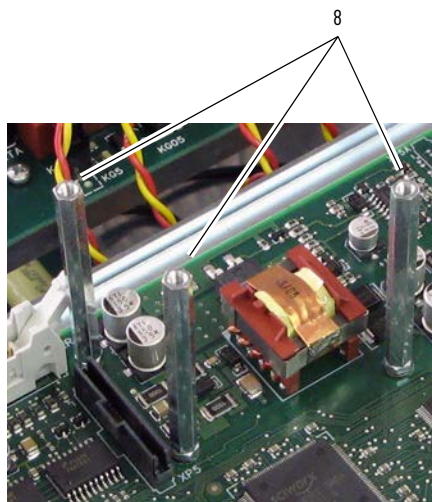

Tightening torque:  
1.0 N·m (8.9 lb·in)

Note: Frame A shown.

## Install the Communication Adapter and EMI Shield

Install the communication adapter and EMI shield in reverse order of removal.

## Switching Power Supply Fuse Removal and Installation

### Remove the Fuse on the Switching Power Supply Circuit Board

1. Read the General Safety Precautions on page [10](#).
2. Remove power from the drive. See Remove Power from the Drive on page [48](#).
3. Remove the top control panel, bottom control panel, and I/O and control terminal covers from the drive. See Remove the Protective Covers on page [51](#).
4. Loosen the eight hexalobular screws that secure the protective plastic cover to the control pan and remove the cover.

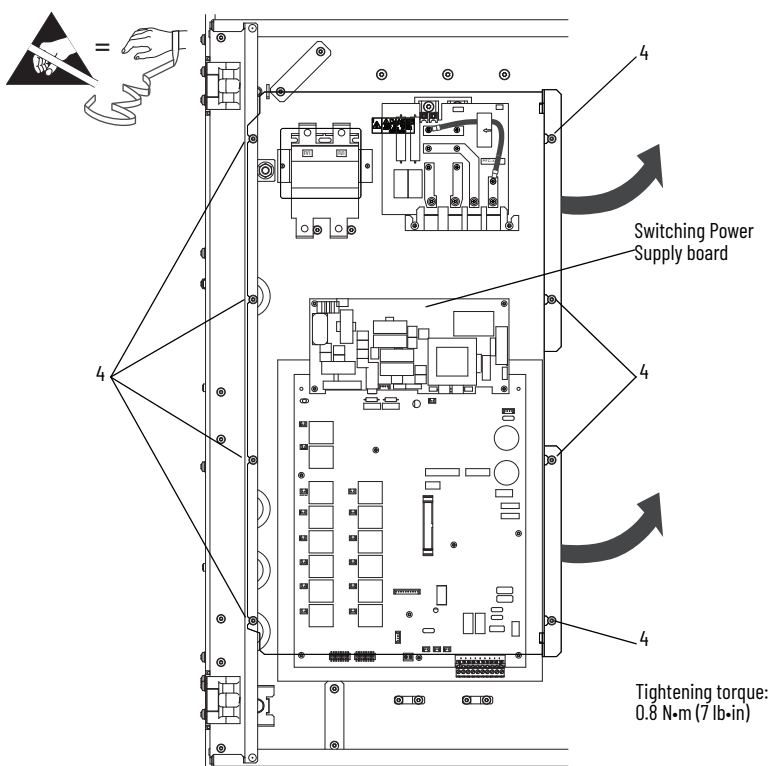

5. Remove the fuse by inserting a screwdriver in the slot on the fuse holder (F1), carefully pushing up and turning the fuse counterclockwise. When the fuse holder releases, remove the holder and fuse.

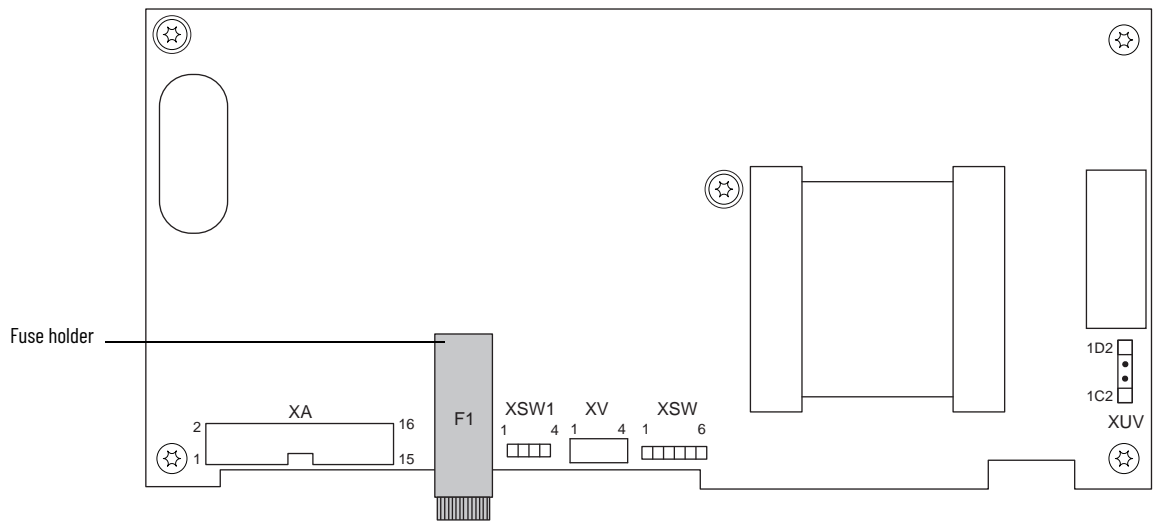

## Install the Fuse on the Switching Power Supply Circuit Board

Install the new fuse in the reverse order of removal. Resolver Feedback and Interface Circuit Board Removal and Installation

### Remove the Resolver Feedback and Interface Circuit Boards

1. Read the General Safety Precautions on page [10](#).
2. Remove power from the drive. See Remove Power from the Drive on page [48](#).
3. Remove the bottom and I/O and control terminal protective covers. See Remove the Protective Covers on page [51](#).

---

**IMPORTANT** Mark all connections and wires before removal to avoid incorrect wiring during reassembly.

---

4. Disconnect the plug-in terminal blocks from the resolver feedback and resolver interface boards.

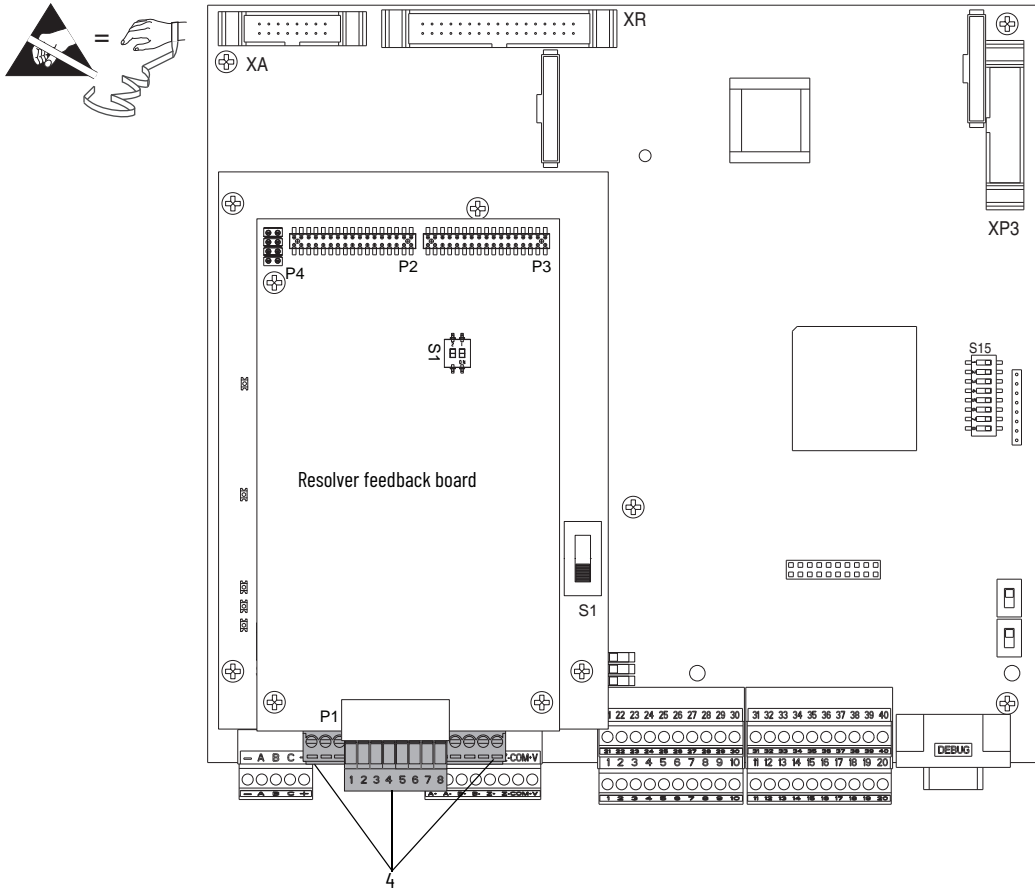

- Remove the three hexalobular screws that secure the resolver feedback board to the stand-offs on the resolver interface board and carefully remove the resolver feedback board.

**IMPORTANT** The resolver feedback board is connected to the resolver interface board below it via stacker connector pins at connectors P2 and P3. Lift the resolver feedback board straight up during removal to avoid any damage to the connector pins.

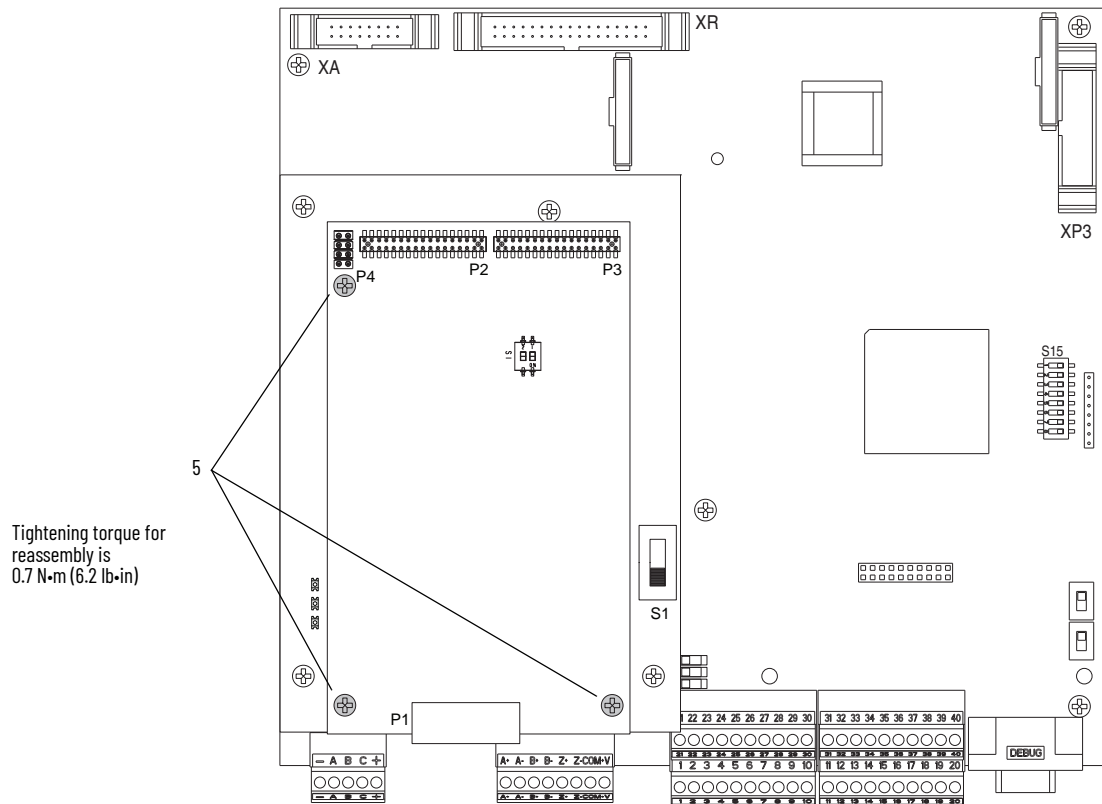

6. Remove the three stand-offs from the resolver interface board.

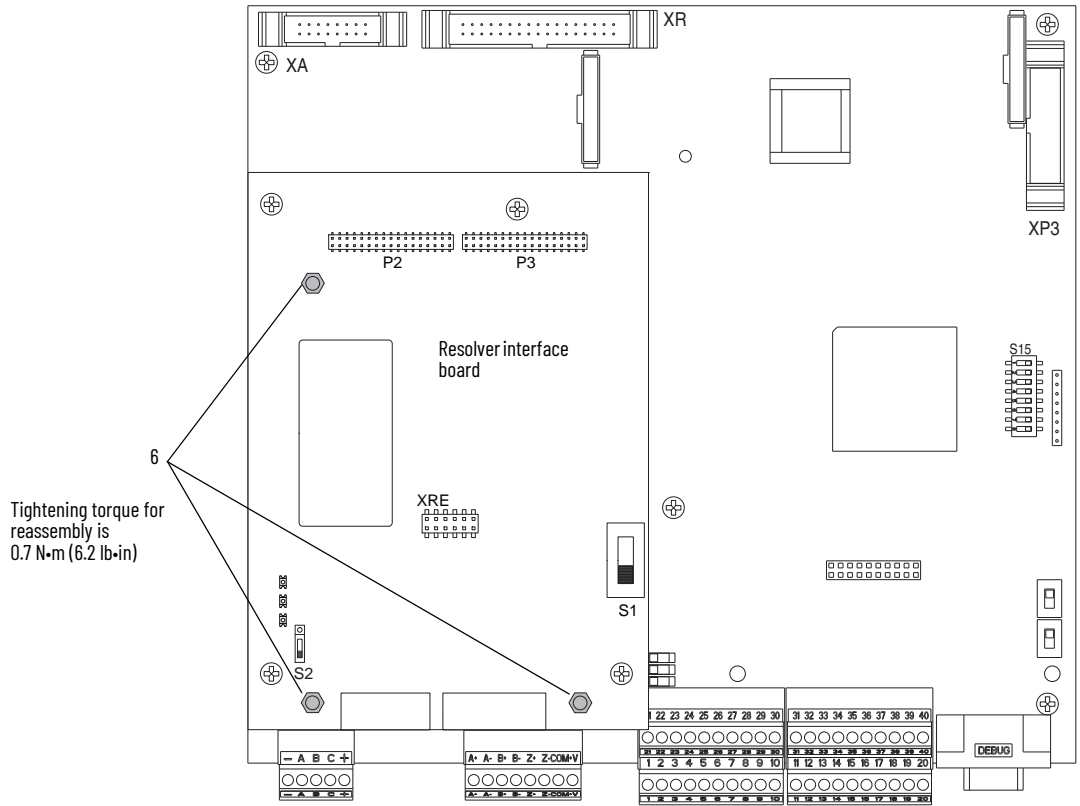

- Remove the four hexalobular screws that secure the resolver interface board to the control board and remove the resolver interface board.

**IMPORTANT** The resolver interface board is connected to the control board below it via a stacker connector pin at connector XRE. Lift the resolver interface board straight up during removal to avoid any damage to the connector pin.

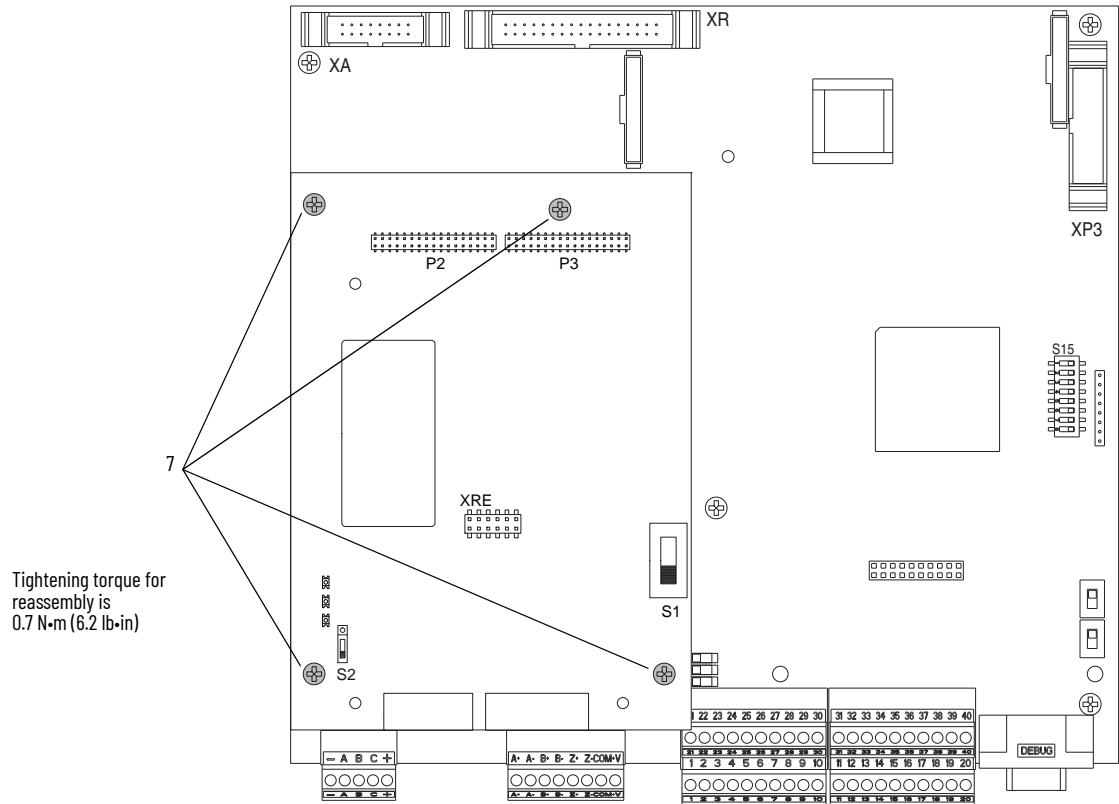

## Install the Resolver Feedback and Interface Circuit Boards

Install the resolver feedback and interface boards in reverse order of removal.

### I/O Expansion Circuit Board Removal and Installation

#### Remove the I/O Expansion Circuit Board

1. Read the General Safety Precautions on page [10](#).
2. Remove power from the drive. See Remove Power from the Drive on page [48](#).
3. Remove the bottom and I/O and control terminal protective covers. See Remove the Protective Covers on page [51](#).
4. If installed, remove the resolver feedback option and interface boards. See Install the new fuse in the reverse order of removal. Resolver Feedback and Interface Circuit Board Removal and Installation on page [58](#).

---

Mark all connections and wires before removal to avoid incorrect wiring during reassembly.

---

5. Remove the plug-in I/O terminal blocks with the wiring kept in place.
6. Remove the two M3 x 6 mm screws and washers that secure the I/O expansion board to the stand-offs on the control board.

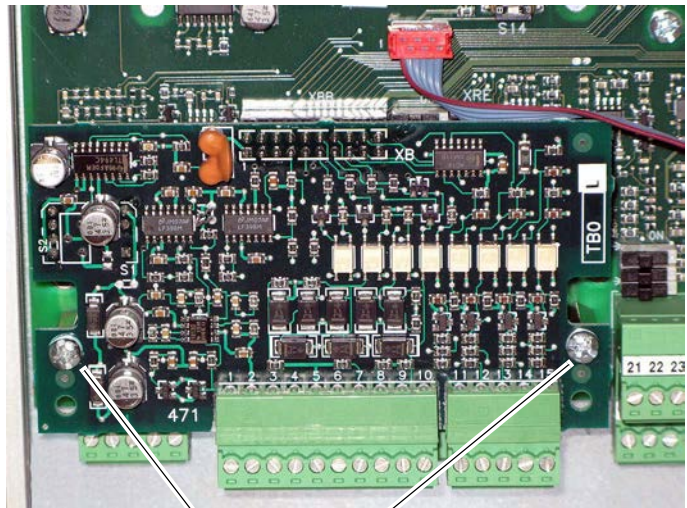

6

Tightening torque:  
1.0 N·m (8.9 lb·in)

7. Carefully pull the I/O expansion board off connector XBB on the control board.

8. Remove the two stand-offs from the control board.

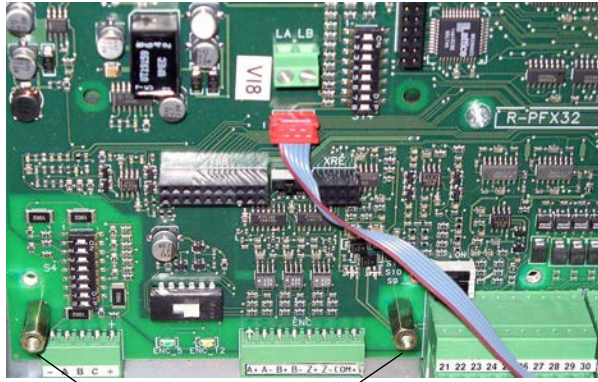

Tightening torque:  
1.0 N·m (8.9 lb·in)

9. Install one of the existing screws in the lower left corner of the control circuit board.

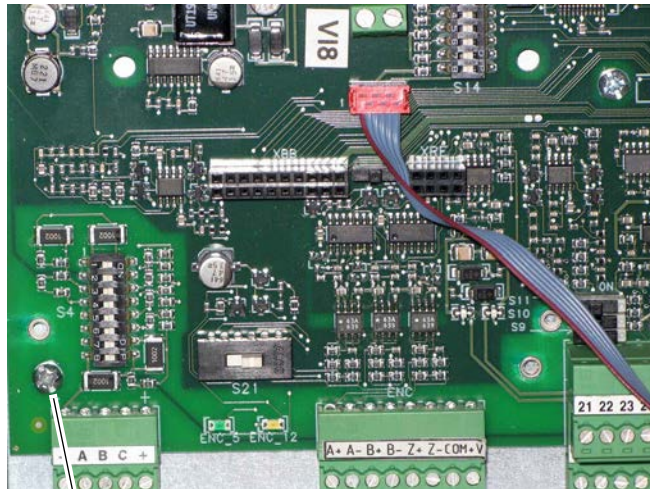

Tightening torque:  
1.0 N·m (8.9 lb·in)

## Install the I/O Expansion Circuit Board

Install the I/O expansion board in reverse order of removal.

## 115V AC to 24V DC I/O Converter Circuit Board Removal and Installation

### Remove the 115V AC to 24V DC I/O Converter Circuit Board

1. Read the General Safety Precautions on page [10](#).
2. Remove power from the drive. See Remove Power from the Drive on page [48](#).
3. Remove the bottom and I/O and control terminal protective covers. See Remove the Protective Covers on page [51](#).

---

Mark all connections and wires before removal to avoid incorrect wiring during reassembly.

---

4. Remove the plug-in I/O terminal blocks with the wiring kept in place.
5. Remove the two M3 x 6 mm screws and washers that secure the I/O converter board to the stand-offs on the control board and remove the I/O converter board.

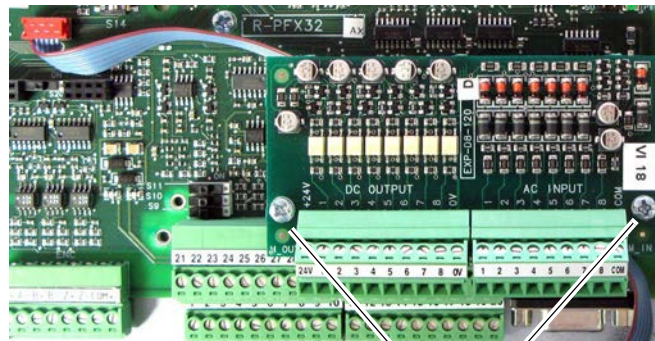

5

Tightening torque:  
1.0 N·m (8.9 lb·in)

6. Remove the two stand-offs from the control board.

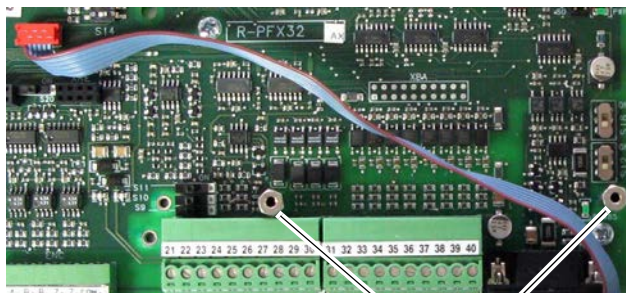

6

Tightening torque:  
1.0 N·m (8.9 lb·in)

## Install the 115V AC to 24V DC I/O Converter Circuit Board

Install the 115V AC to 24V DC I/O converter board in reverse order of removal.

## Control Circuit Board Removal and Installation



### Remove the Control Circuit Board

1. Save the drive and communications adapter parameter configuration to a HIM Set or by downloading the drive and adapter parameters to an offline database file using DriveExecutive™. See the PowerFlex Digital DC Drive User Manual, publication 20P-UM001, for information on using the HIM or the on-line Help provided with DriveExecutive for more information on HIM Sets or using the HIM.
1. Read the General Safety Precautions on page [10](#).
2. Remove power from the drive. See Remove Power from the Drive on page [48](#).
3. Remove the bottom and I/O and control terminal protective covers. See Remove the Protective Covers on page [51](#).
4. Remove the communication adapter and EMI shield from the control board. See Communication Adapter and EMI Shield Removal and Installation on page [54](#).
5. If installed, remove the resolver feedback option and interface boards. See Install the new fuse in the reverse order of removal. Resolver Feedback and Interface Circuit Board Removal and Installation on page [58](#).
6. If installed, remove the I/O expansion circuit board. See I/O Expansion Circuit Board Removal and Installation on page [62](#).
7. If installed, remove the 115V AC to 24V DC I/O converter circuit board. See 115V AC to 24V DC I/O Converter Circuit Board Removal and Installation on page [64](#).
8. Record all switch and jumper settings on the control board. See the TPDFlex DC Converters User Manual, publication 1S7TFLEXUM0 for more information.

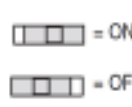
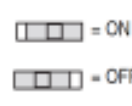
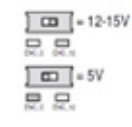
**Jumper Settings Series A**

ID	Jumper Switch	Function	Factory Default	Example
①	S0	For factory boot flashing only. Leave set to the factory setting. Jumper On Firmware boot Jumper Off Normal function	Jumper Off	
	S1	For factory boot flashing only. Leave set to the factory setting. Jumper On Write firmware boot code Jumper Off Boot code on flash is protected	Jumper Off	
	S2	Not used. Leave set to the factory setting.	Jumper Off	
	S3	For factory boot flashing only. Leave set to the factory setting. Jumper On Reset Jumper Off Normal function	Jumper Off	
②	S4	Configures the input voltage of the DC analog tachometer. See Table 28 on page 80 for configuration.	90V	...
③	S9	Configures the input signal of Analog Input 1 (terminals 1 and 2): Position Off 0...20 mA / 4...20 mA Position On 0...10V / ±10V Par 71 [Anlg In1 Config] must be programmed to match the input signal type selected with this switch.	On	
	S10	Configures the input signal of Analog Input 2 (terminal 3 and 4): Position Off 0...20 mA / 4...20 mA Position On 0...10V / ±10V Par 76 [Anlg In2 Config] must be programmed to match the input signal type selected with this switch.	On	
	S11	Configures the input signal of Analog Input 3 (terminals 5 and 6): Position Off 0...20 mA / 4...20 mA Position On 0...10V / ±10V Par 81 [Anlg In3 Config] must be programmed to match the input signal type selected with this switch.	On	
④	S12	Not used. Leave set to the factory setting.	Off	...
⑤	S14	Field current resistors setting, see Field Current Configuration on page 62. The value that is selected with switch S14 must be entered in Par 374 [Drv Fld Brdg Cur] when the drive is commissioned. For permanent magnet motor or external field controller applications, leave set to the factory default settings.	Minimum field current rating based on the drive size.	...
⑥	S15	Configuration of the control circuit board to the appropriate drive size. Leave set to the factory setting, unless the control board has been supplied as a spare part. See DIP Switch S15 Settings on page 80 for switch configuration that is based on drive current rating code.	Armature current based on drive size.	...
⑦	S18	Not used. Leave set to the factory setting.	Off	...
⑧	S20	Monitoring (reported by Par 652 [Encoder Err Chk]) of the Z channel of the Digital Encoder on connector XE2. This switch adds/removes the Z channel in the encoder hardware check circuit. Par 652 enables/disables reading the result of that hardware check. Position Off Z channel monitored Position On Z channel not monitored	On	
⑨	S21	Encoder power supply voltage and input selection: This switch setting determines both the power supply (input) and feedback level (output) voltage of the connected encoder. When control power is supplied to the drive, the appropriate LED lights to indicate the selection of the switch. ENC_5 +5V encoder (2.5...5.4V input range) ENC_12 +12...15V encoder (+5.4V...15.2V input range)	12...15V	

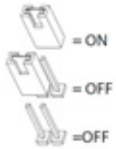
## Jumper Settings Series B

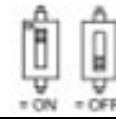
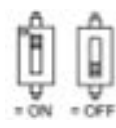
ID	Jumper Switch	Function	Factory Default	Example
1	S0	Not used. Leave set to the factory setting.	Jumper Off	
	S1	Not used. Leave set to the factory setting.	Jumper Off	
	S2	For factory boot flashing only. Leave set to the factory setting. Jumper On Boot mode Jumper Off Normal function	Jumper Off	
	S3	For factory boot flashing only. Leave set to the factory setting. Jumper On Reset Jumper Off Normal function	Jumper Off	
2	S4	Configures the input voltage of the DC analog tachometer. See Table 28 on page 80 for configuration.	90V	...
3	S9	Configures the input signal of Analog Input 1 (terminals 1 and 2): Position On 0...20 mA / 4...20 mA Position Off 0...10V / ±10V Par 71 [Anlg In1 Config] must be programmed to match the input signal type selected with this switch.	Off	
	S10	Configures the input signal of Analog Input 2 (terminal 3 and 4): Position On 0...20 mA / 4...20 mA Position Off 0...10V / ±10V Par 76 [Anlg In2 Config] must be programmed to match the input signal type selected with this switch.	Off	
	S11	Configures the input signal of Analog Input 3 (terminals 5 and 6): Position On 0...20 mA / 4...20 mA Position Off 0...10V / ±10V Par 81 [Anlg In3 Config] must be programmed to match the input signal type selected with this switch.	Off	
4	S12	Not used. Leave set to the factory setting	Off	...
5	S14	Field current resistors setting, see Field Current Configuration on page 62. The value that is selected with switch S14 must be entered in Par 374 [Drv Fld Brdg Cur] when the drive is commissioned. For permanent magnet motor or external field controller applications, leave set to the factory default settings.	Minimum field current rating based on the drive size.	...
6	S15	Configuration of the control circuit board to the appropriate drive size. Leave set to the factory setting, unless the control board has been supplied as a spare part. See DIP Switch S15 Settings on page 80 for switch configuration that is based on drive current rating code.	Armature current based on drive size.	...
7	S18	Not used. Leave set to the factory setting.	Off	...
8	S20	Monitoring (reported by Par 652 [Encoder Err Chk]) of the Z channel of the Digital Encoder on connector XE2. This switch adds/removes the Z channel in the encoder hardware check circuit. Par 652 enables/disables reading the result of that hardware check. Position On Z channel monitored Position Off Z channel not monitored	Off	
9	S21	Encoder power supply voltage and input selection: This switch setting determines both the power supply (input) and feedback level (output) voltage of the connected encoder. When control power is supplied to the drive, the appropriate LED lights to indicate the selection of the switch. Position On +12...15V encoder (+5.4V...15.2V input range) Position Off +5V encoder (2.5...5.4V input range)	On (12...15 V)	

9. Carefully disconnect the cables from connectors XA, XR, and XFCD on the control board.
10. Remove the plug-in I/O and control terminal blocks with the wiring kept in place.

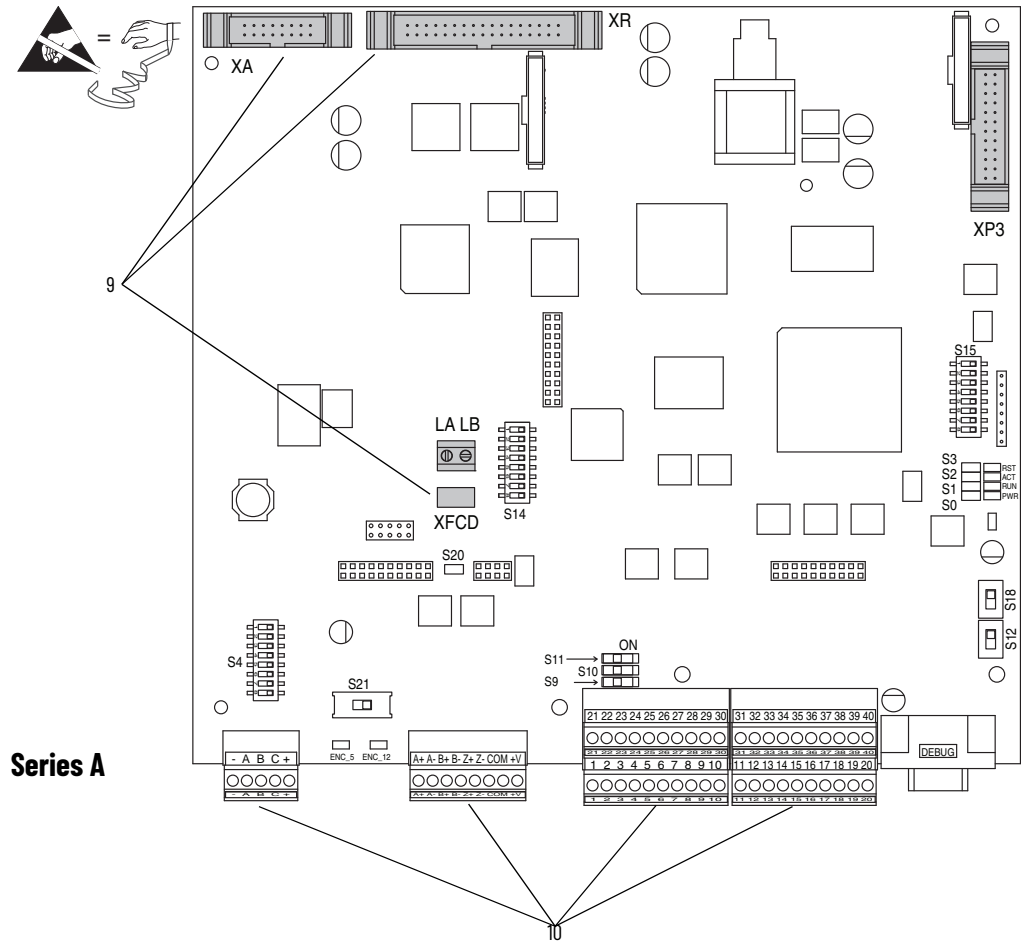

Communication adapter and optional boards not shown.

Series B

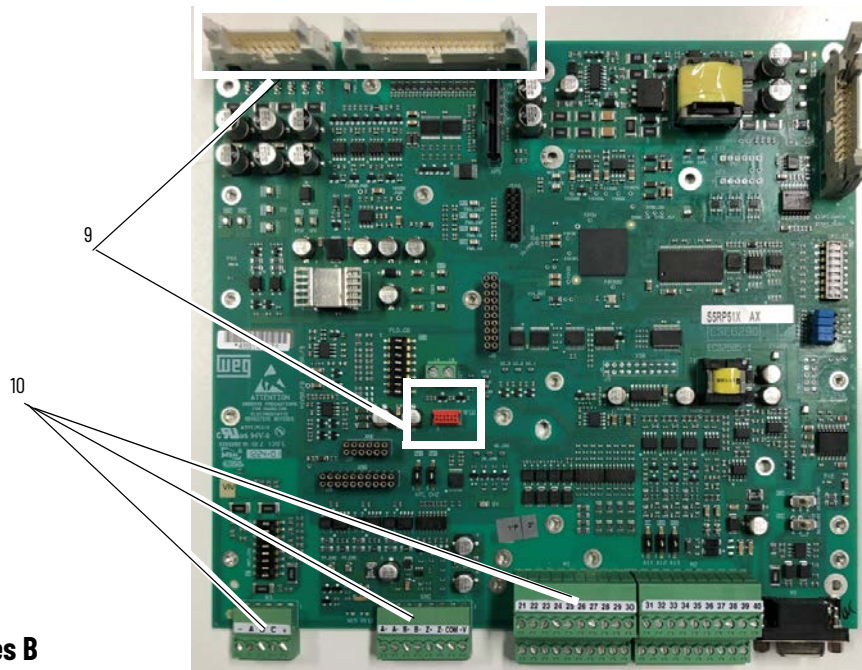

- Remove the five M3 x 6 mm screws and washers that secure the control board to the control EMI shield and remove the control board.

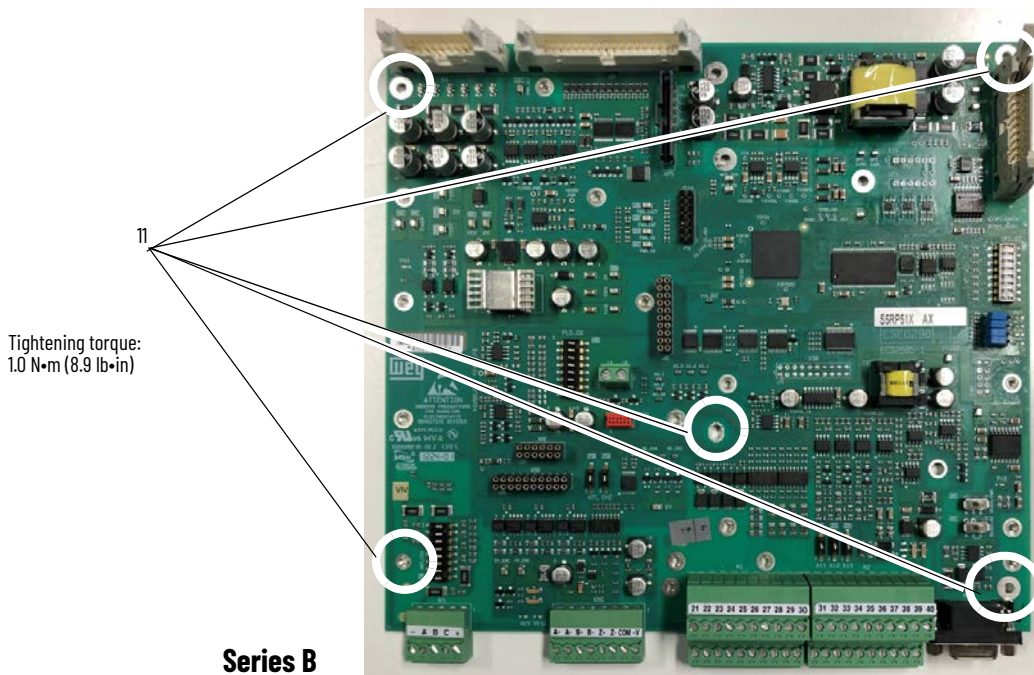
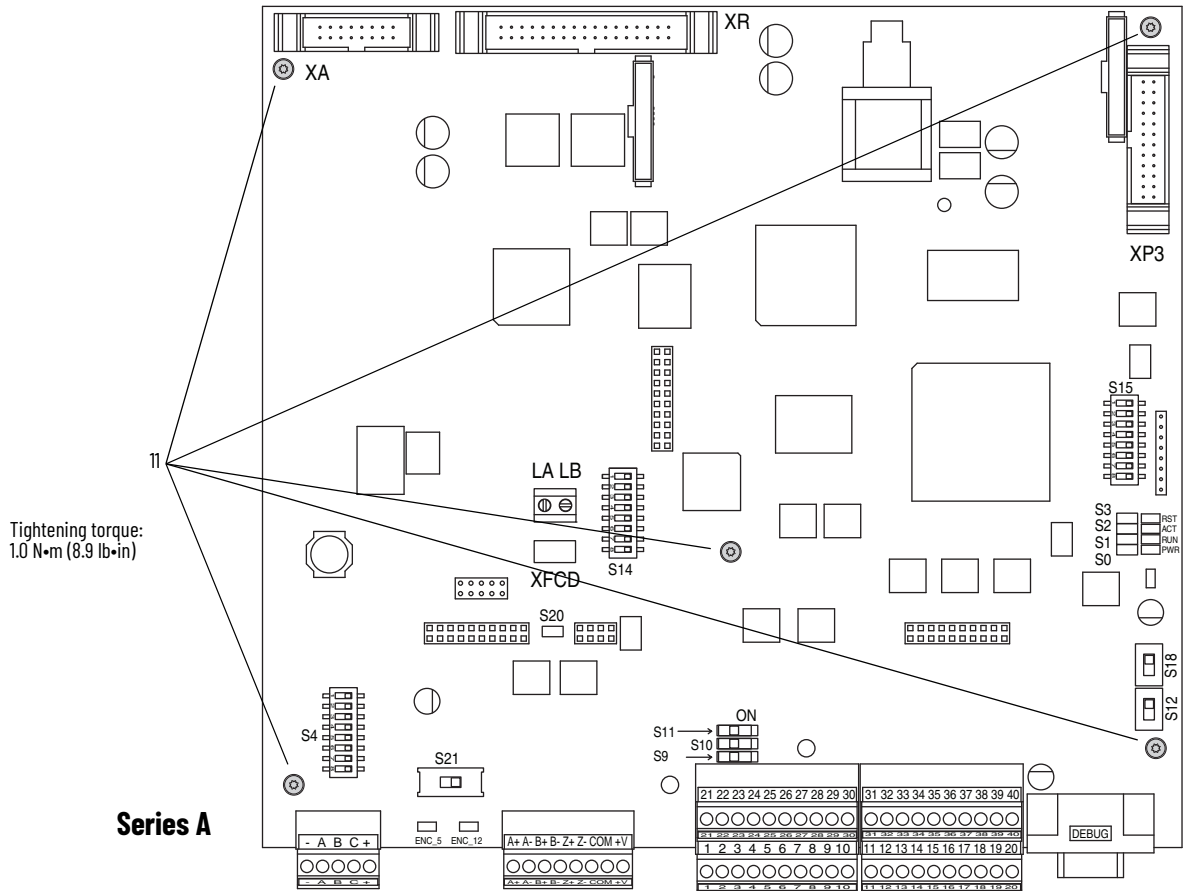

## Install the Control Circuit Board

Install the control board in reverse order of removal.

- Verify that all DIP switches are set to the correct configuration based on your recorded settings. See page 65.

## Switching Power Supply Circuit Board Removal and Installation

### Remove the Switching Power Supply Circuit Board

1. Read the General Safety Precautions on page 10.
2. Remove power from the drive. See Remove Power from the Drive on page 48.
3. Remove the top control panel, bottom control panel, and I/O and control terminal covers from the drive. See Remove the Protective Covers on page 51.
4. Loosen the eight hexalobular screws that secure the protective plastic cover to the control pan and remove the cover.

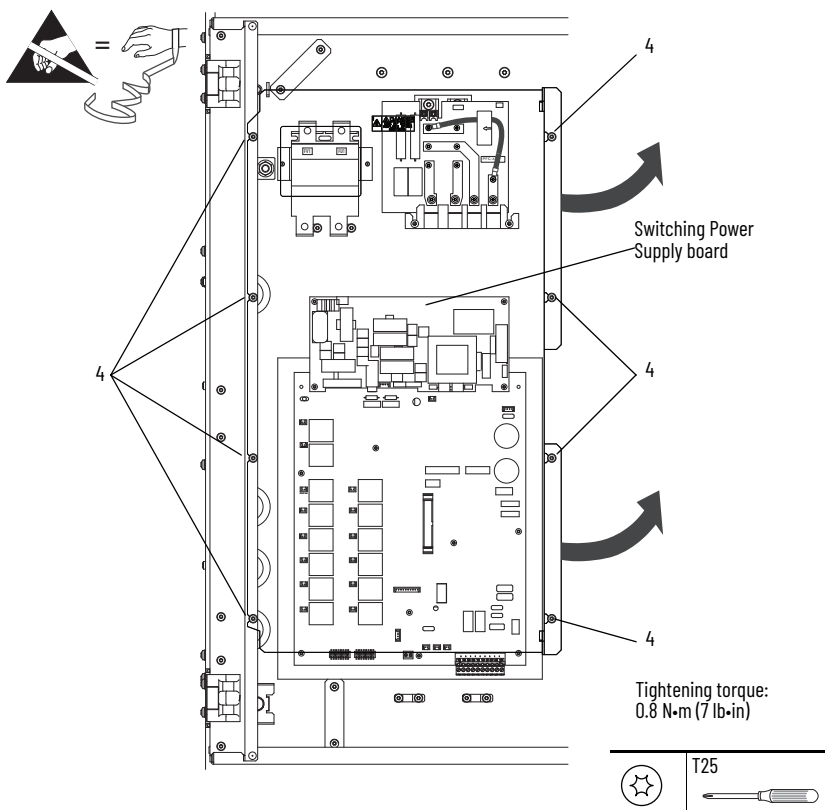

**IMPORTANT** Mark all connections and wires before removal to avoid incorrect wiring during reassembly.

5. Disconnect the cables from connector XA and XUV on the switching power supply board.
6. Remove the five screws that secure the board to the control EMI shield and remove the board.

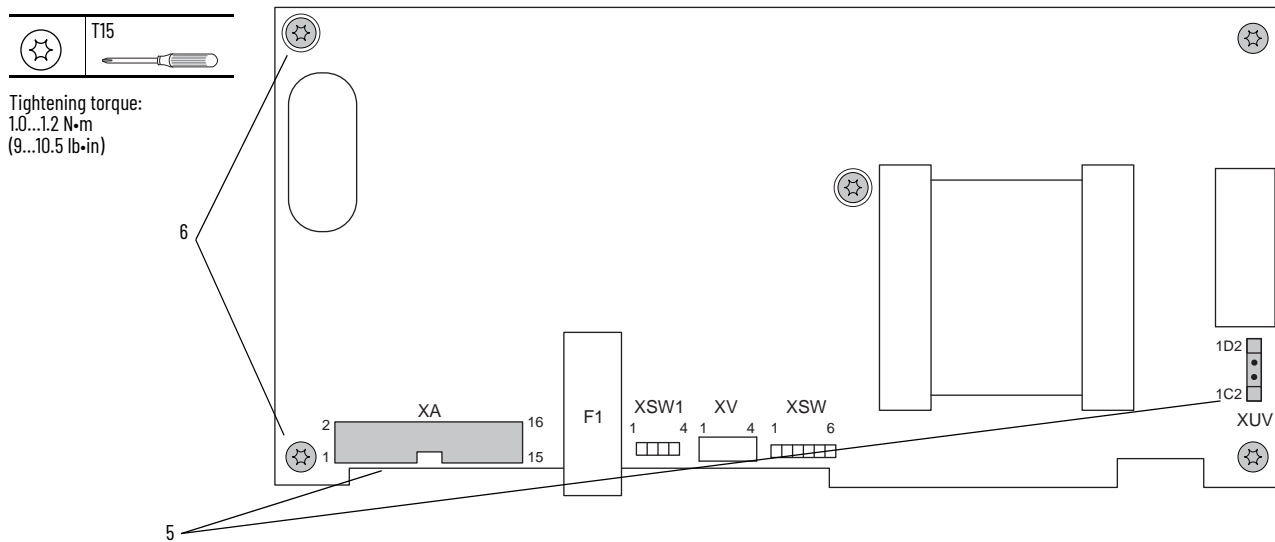

## Install the Switching Power Supply Circuit Board

Install the switching power supply circuit board in the reverse order of removal.

- Inspect the 16 Pin cable that connects to connector XA on the switching power supply board for burn marks, cracks or a loose connector. If necessary, replace the existing cable with the new cable provided.

## Pulse Transformer Circuit Board Removal and Installation

### Remove the Pulse Transformer Circuit Board

1. Read the General Safety Precautions on page [10](#).
2. Remove power from the drive. See Remove Power from the Drive on page [48](#).
3. Remove the top control panel, bottom control panel, and I/O and control terminal covers from the drive. See Remove the Protective Covers on page [51](#).

- Loosen the eight hexalobular screws that secure the protective plastic cover to the control pan and remove the cover.

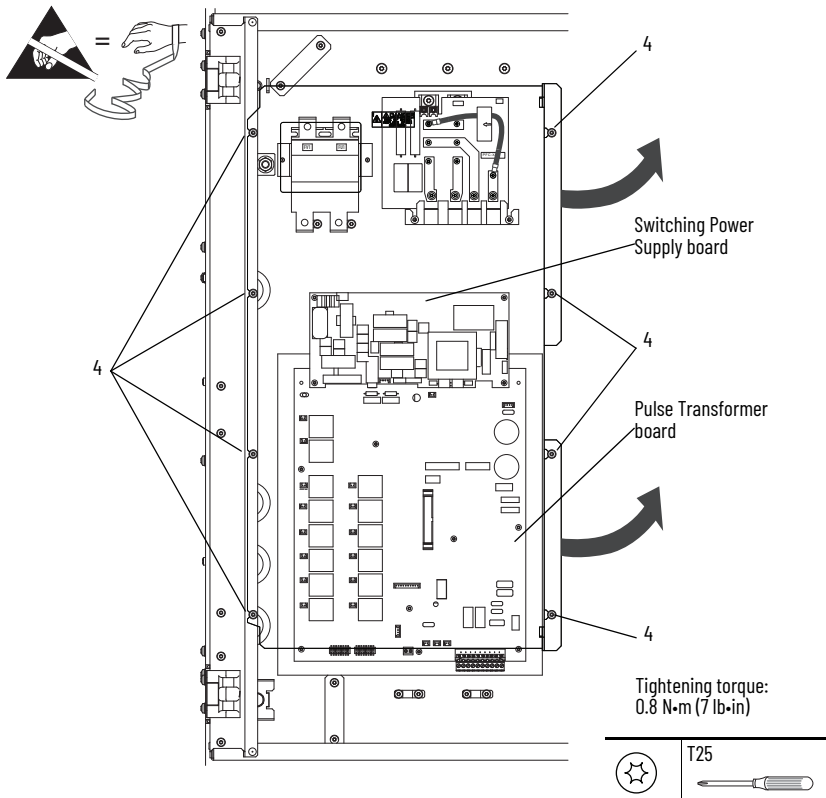

**IMPORTANT** Mark all connections and wires before removal to avoid incorrect wiring during reassembly.

- Remove the switching power supply circuit board. See Remove the Switching Power Supply Circuit Board on page 70.
- Disconnect the (red and white) gate leads from connectors XP1 and XP2 at the top-left corner of the board. Refer to the pulse transformer board layout on the following page.
- Disconnect the appropriate gate leads from the pulse transformer board:
  - For non-regenerative drives, each pair of (red and white) gate lead cables from connectors KG1...KG6.
  - For regenerative drives, each pair of (red and white) gate lead cables from connectors KG1...KG6 and KG01...KG06.
- Disconnect the cables from the following connectors: XUV, XCD\_IO, XUVW, XCD, XR, XTA, X3, X4 and XSPF. Also, carefully remove the ribbon cable (from XR) from the cable standoff on the board.
- Remove the plug-in terminal block at the bottom of the pulse transformer board.
- Remove the two hexagonal standoffs and washers from the pulse transformer board.
- Remove the six hexalobular screws that secure the pulse transformer board to the control pan and remove the board.

Components that are shown within dashed lines are only on the pulse transformer board for regenerative drives.

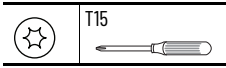

Tightening torque:  
1.0...1.2 N·m  
(9...10.5 lb·in)

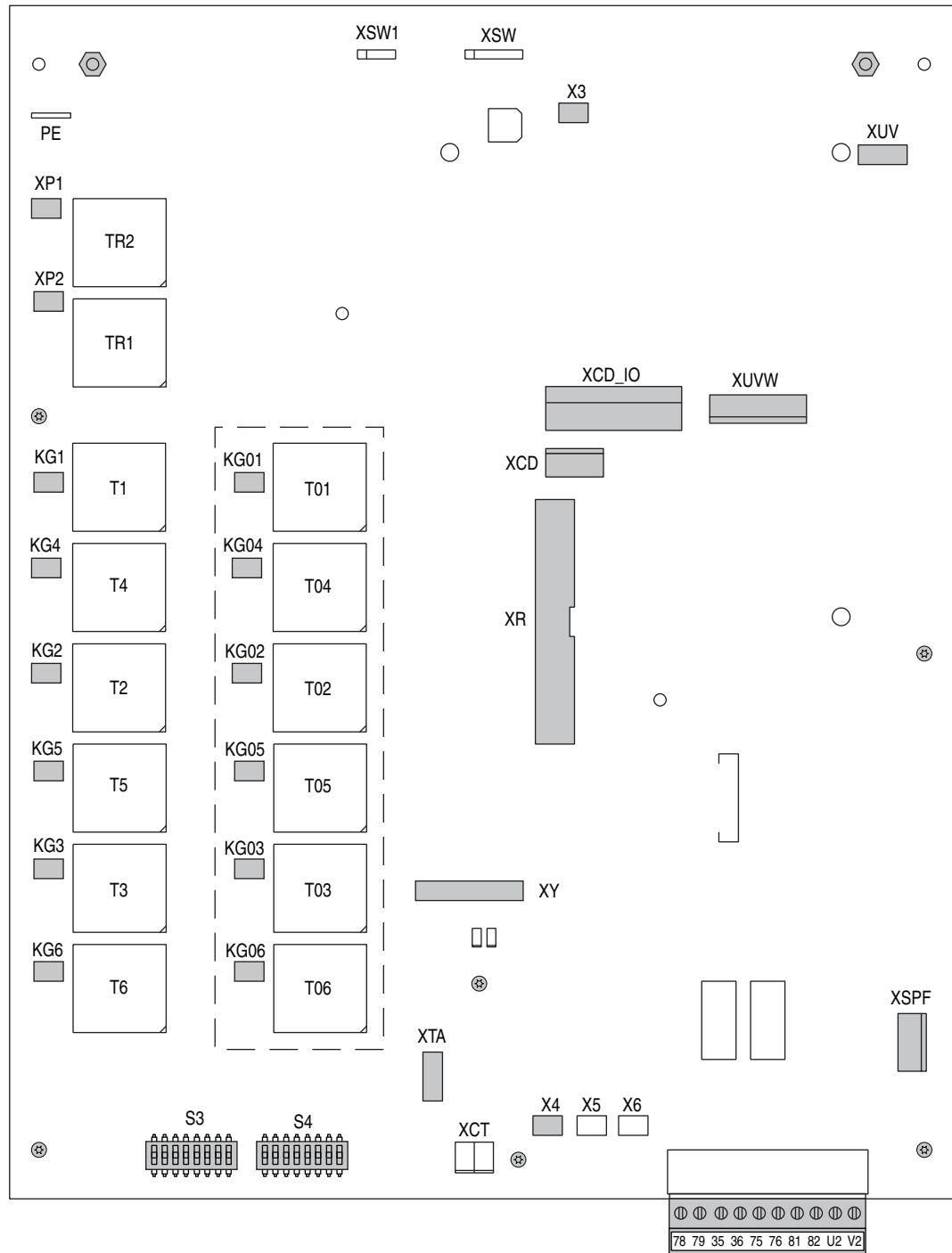

## Install the Pulse Transformer Board

Install the new pulse transformer board in reverse order of removal.

- Inspect the existing gate lead cables for burn marks, cracks or loose connectors. Replace the cables if necessary with the new cables provided.
- Set DIP switches S3 and S4 on the pulse transformer board to the correct settings based on the appropriate table below. Refer to the illustration on the previous page for location.

A blank cell below a switch in tables below indicate that the setting is "OFF".

Table 13 - 230V AC Input Drives

Drive Current Rating Code	DC Amps	AC Line Amps	HP	DIP Switch S3								DIP Switch S4							
				S3-1	S3-2	S3-3	S3-4	S3-5	S3-6	S3-7	S3-8	S4-1	S4-2	S4-3	S4-4	S4-5	S4-6	S4-7	S4-8
875	875	718	250		ON			ON			ON								
1050	1050	861	300	ON	ON			ON		ON									

Table 14 - 460V AC Input Drives

Drive Current Rating Code	DC Amps	AC Line Amps	HP	DIP Switch S3								DIP Switch S4							
				S3-1	S3-2	S3-3	S3-4	S3-5	S3-6	S3-7	S3-8	S4-1	S4-2	S4-3	S4-4	S4-5	S4-6	S4-7	S4-8
830	830	681	500		ON			ON		ON									
996	996	817	600					ON		ON				ON					
1K1	1162	953	700		ON			ON	ON		ON								
1K3	1328	1089	800	ON				ON	ON	ON									
1K4	1494	1225	900			ON			ON	ON			ON						

Table 15 - 575V AC Input Drives

Drive Current Rating Code	DC Amps	AC Line Amps	HP	DIP Switch S3								DIP Switch S4							
				S3-1	S3-2	S3-3	S3-4	S3-5	S3-6	S3-7	S3-8	S4-1	S4-2	S4-3	S4-4	S4-5	S4-6	S4-7	S4-8
810	810	664	600	ON				ON		ON									
1K0	1080	886	800		ON	ON		ON	ON										
1K2	1215	996	900				ON	ON	ON			ON							
1K3	1350	1107	1000			ON	ON		ON	ON									
1K4	1668	1384	1250						ON		ON		ON	ON					

Table 16 - 690V AC Input Drives

Drive Current Rating Code	DC Amps	AC Line Amps	HP	DIP Switch S3								DIP Switch S4							
				S3-1	S3-2	S3-3	S3-4	S3-5	S3-6	S3-7	S3-8	S4-1	S4-2	S4-3	S4-4	S4-5	S4-6	S4-7	S4-8
678	678	556	600					ON						ON					
791	791	649	700	ON				ON	ON										
904	904	741	800				ON		ON		ON								
1K0	1017	834	900	ON		ON	ON	ON											
1K1	1130	927	1000			ON	ON		ON	ON									
1K2	1243	1019	1100	ON	ON			ON	ON										
1K4	1413	1159	1250			ON		ON	ON		ON								
1K5	1582	1297	1400					ON		ON	ON		ON						

## Field Circuit Board Removal and Installation

### Remove the Field Circuit Board

1. Read the General Safety Precautions on page [10](#).
2. Remove power from the drive. See Remove Power from the Drive on page [48](#).
3. Remove the top control panel, bottom control panel, and I/O and control terminal covers from the drive. See Remove the Protective Covers on page [51](#).
4. Loosen the eight hexalobular screws that secure the protective plastic cover to the control pan and remove the cover.

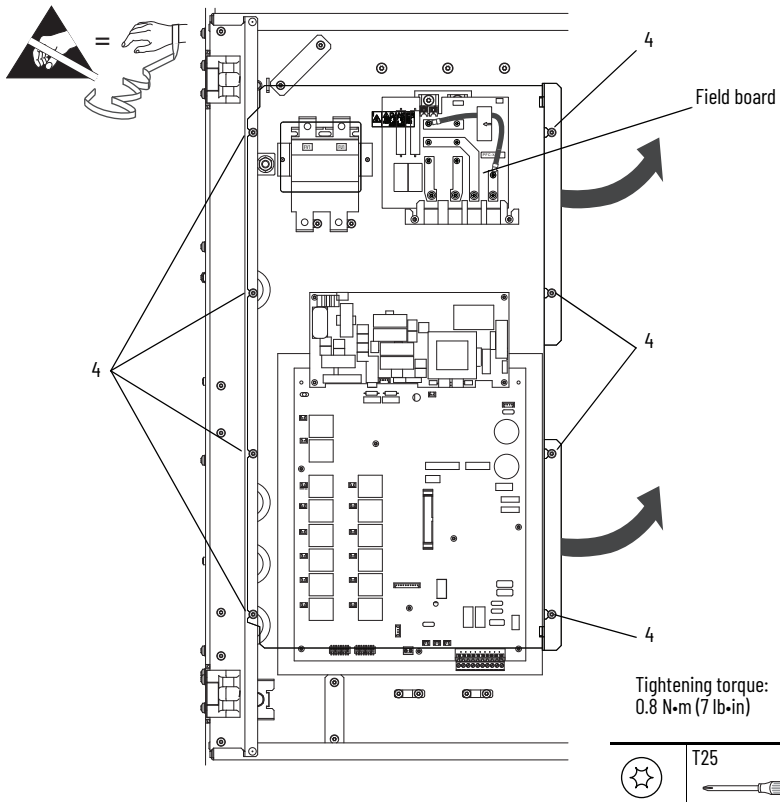

**IMPORTANT** Mark all connections and wires before removal to avoid incorrect wiring during reassembly.

5. Disconnect the cables from connector XFCD and X3 on the field board.
6. Remove the 11 hexalobular screws that secure the field board to the control EMI shield and remove the board.

Note: Field board for 70 A field supply shown.

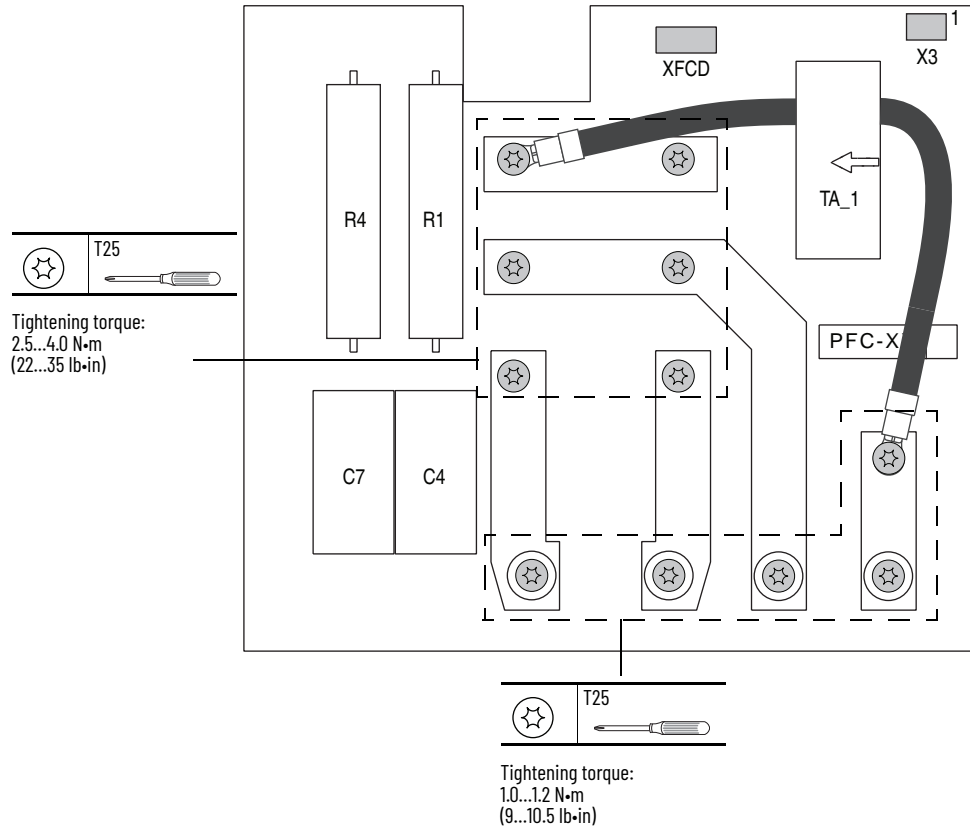

### Install the Field Circuit Board

Install the field circuit board in the reverse order of removal.

- Inspect the cables that connect to connectors XFCD and X3 on the field board for burn marks, cracks, or a loose connector. If necessary, replace the existing cables with the new cables provided.

## Field SCR and Dual Diode Module Removal and Installation

### Remove the Field SCR and Dual Diode Modules

1. Read the General Safety Precautions on page [10](#).

2. Remove power from the drive. See Remove Power from the Drive on page [48](#).
3. Remove the top control panel, bottom control panel, and I/O and control terminal covers from the drive. See Remove the Protective Covers on page [51](#).
4. Remove the field circuit board from the drive. See Remove the Field Circuit Board on page [75](#).

---

**IMPORTANT** Mark all connections and wires before removal to avoid incorrect wiring during reassembly.

---

5. Disconnect the gate lead wires from the connectors at the top of the SCR module.

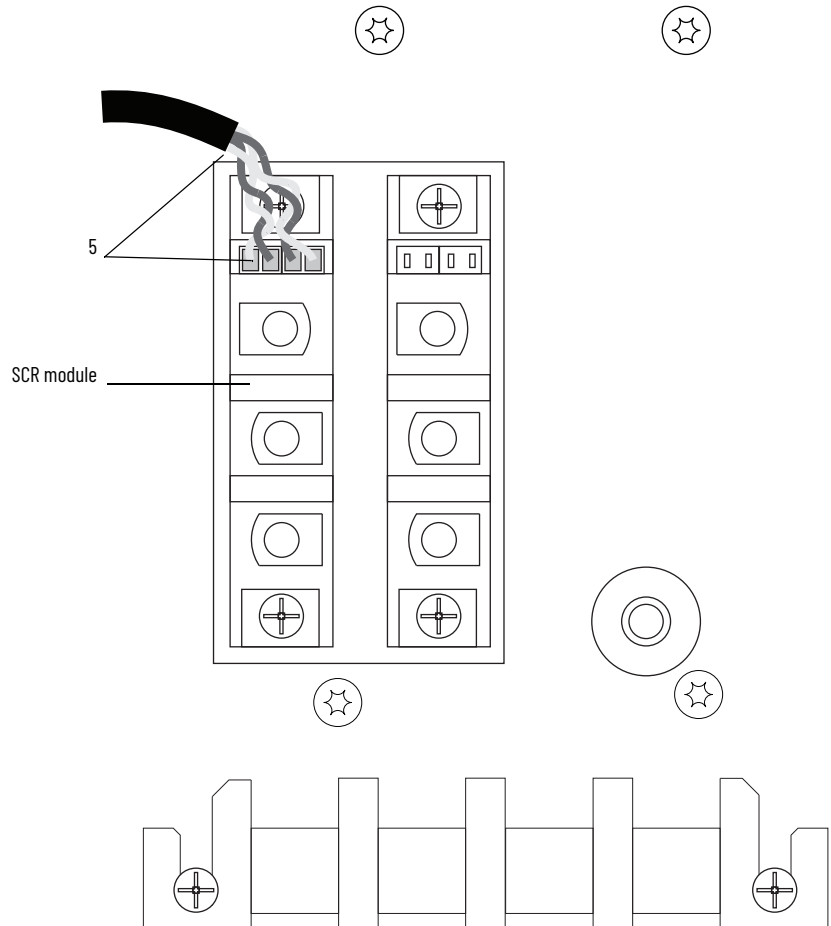

6. Remove the four screws and washers that secure the SCR and dual diode modules to the heatsink and remove the modules.

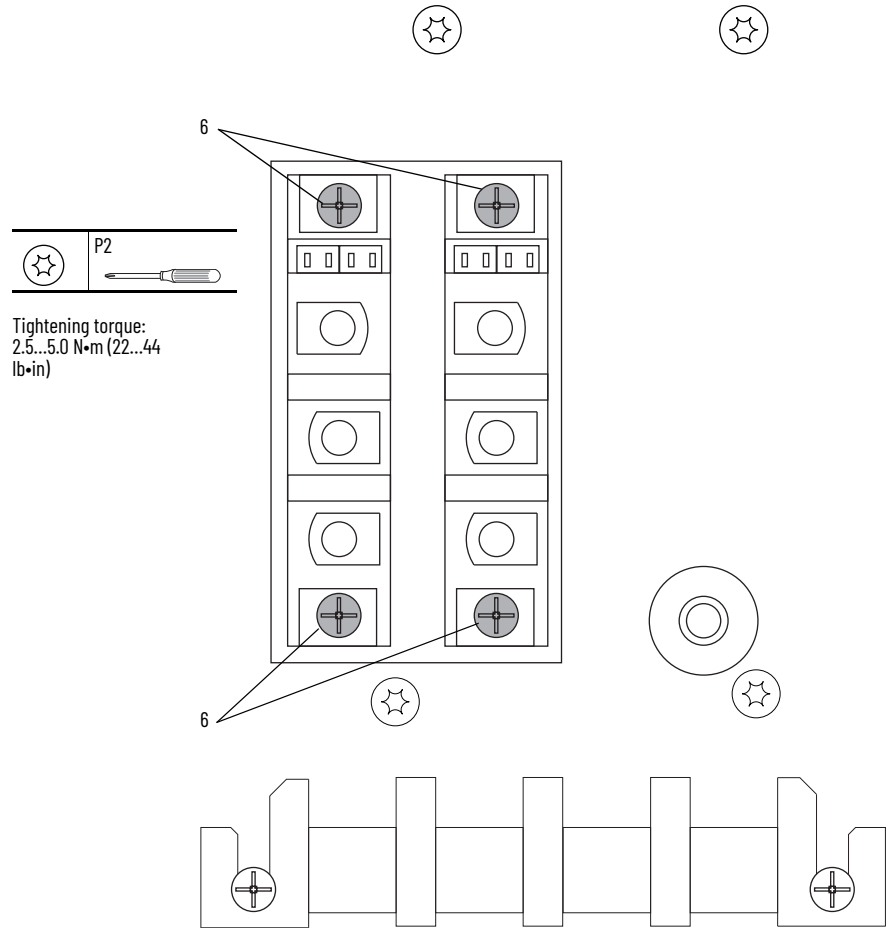

### Install the Field SCR and Dual Diode Modules

Install the field SCR and dual diode modules in the reverse order of removal.

- Apply thermal grease to the bottom of the SCR and dual diode modules before securing them to the heatsink.



**ATTENTION:** Thermal grease must be applied to the bottom of the field SCR and dual diode modules before securing them to the heatsink or damage to the drive may occur.

## Field Fuse Holder Removal and Installation

### Remove the Field Fuse Holder

1. Read the General Safety Precautions on page [10](#).
2. Remove power from the drive. See Remove Power from the Drive on page [48](#).
3. Remove the top control panel, bottom control panel, and I/O and control terminal covers from the drive. See Remove the Protective Covers on page [51](#).
4. Loosen the eight hexalobular screws that secure the protective plastic cover to the control pan and remove the cover.

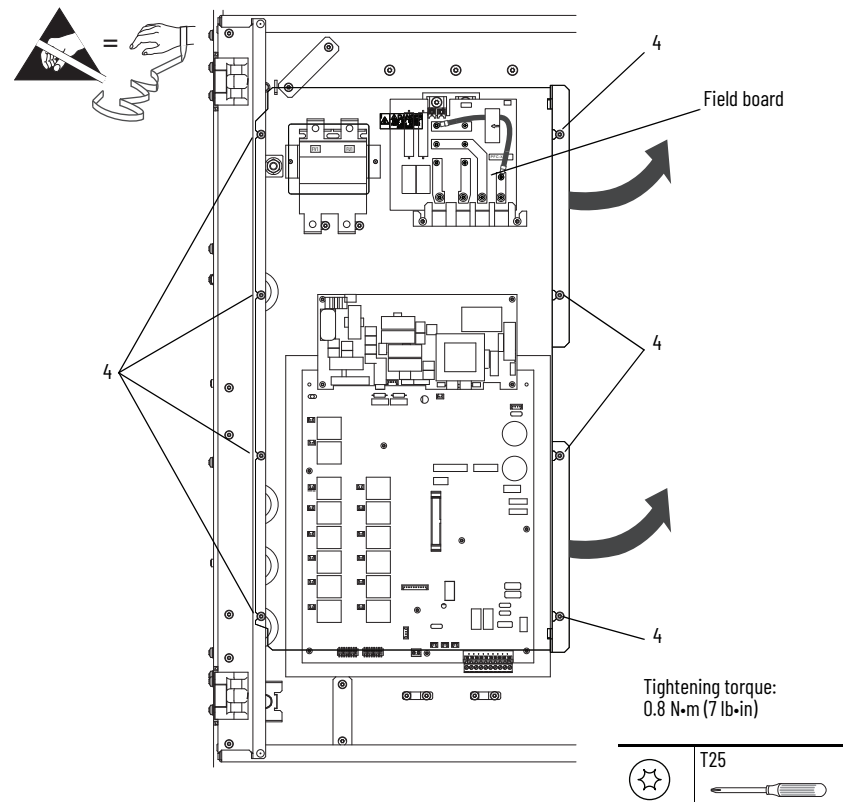

5. Loosen the screws that secure the input and output wires to the fuse holder terminals and remove the wires.
6. If you are reusing the field fuses, pull down on the tabs on the front of the fuse holder and remove the fuses.

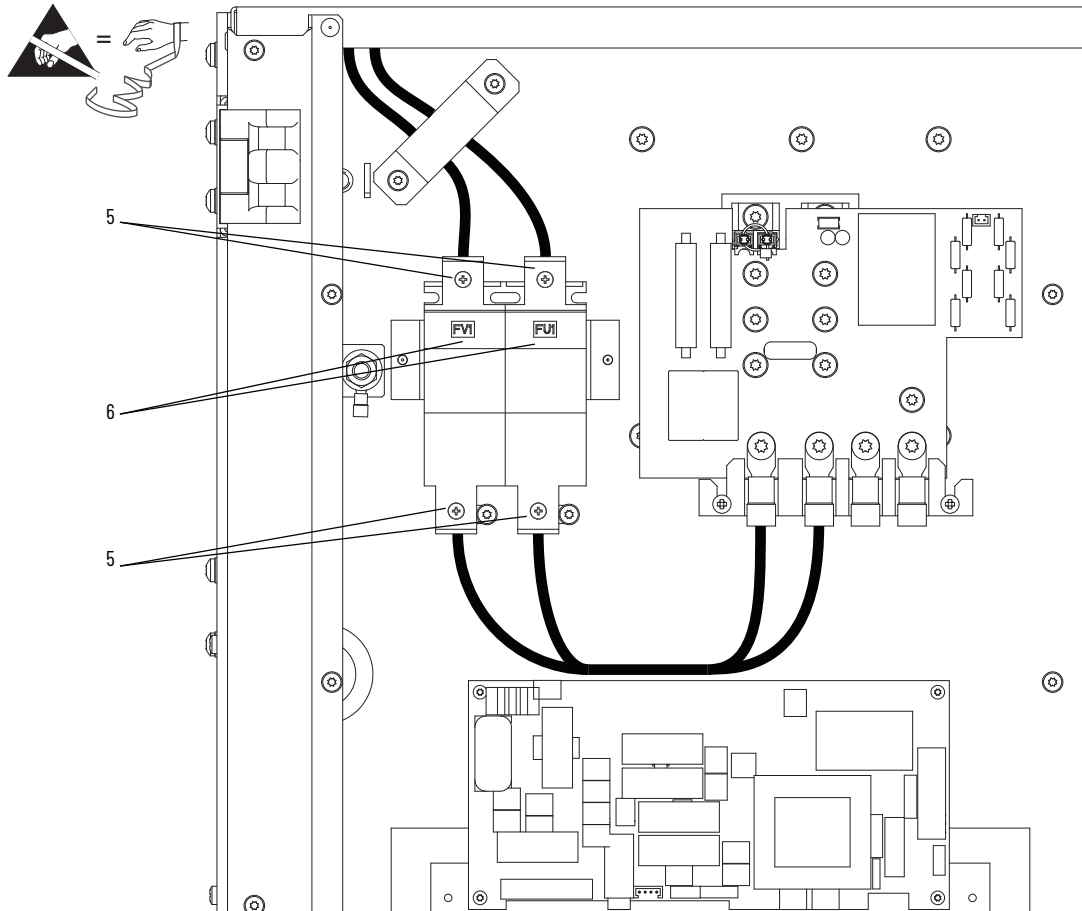

7. Remove the two hexalobular screws that secure the bottom of the fuse holder to the control pan. Retain the screws for reuse.
8. Place the tip of a flathead screwdriver in the slot of the two tabs at the base of the fuse holder and pull down until the tabs pull out from the fuse holder body. When the fuse holder is loose, remove it from the metal support flange.

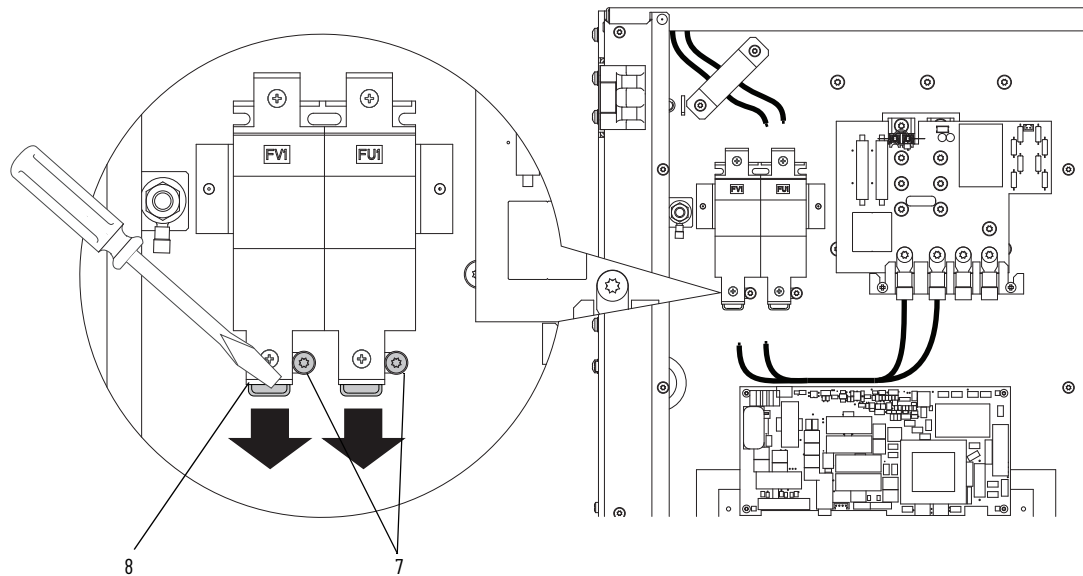

### Install the Field Fuse Holder

Install the field fuse holder in the reverse order of removal.

## Fan Starting Capacitor Removal and Installation

### Remove the Fan Starting Capacitor

**Note:** A fan capacitor is only used on series A, frame D drives. See [Figure 1](#) on page [11](#) for information on identifying series A drives.

1. Read the General Safety Precautions on page [10](#).
2. Remove power from the drive. See [Remove Power from the Drive](#) on page [48](#).
3. Remove the top terminal cover from the drive. See [Remove the Protective Covers](#) on page [51](#).

---

Mark all connections and wires before removal to avoid incorrect wiring during reassembly.

---

4. Cut the cable ties that secure the fan capacitor and fan power wires together.
5. Loosen the screws that secure the fan capacitor wires to the plug-in terminal block at XC on the fan circuit board and remove the wires.

6. Unscrew the fan capacitor from the back of the drive frame and remove the capacitor.

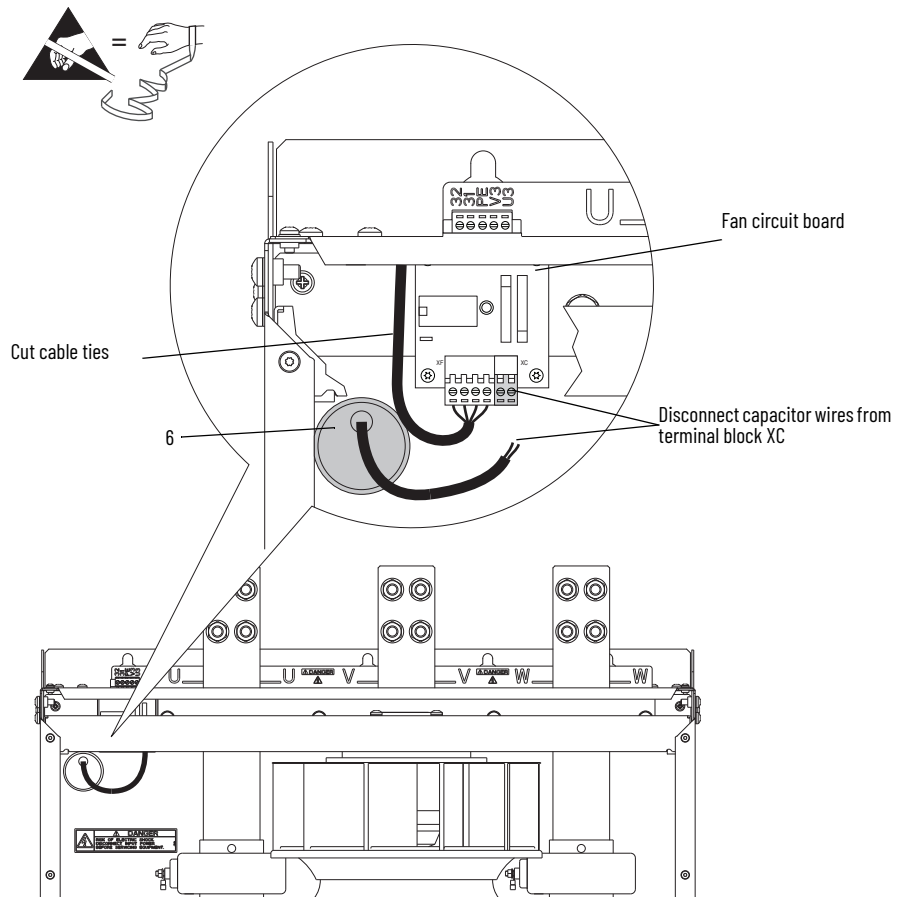

### Install the Fan Starting Capacitor

Install the fan starting capacitor in the reverse order of removal. See the Series A Fan Circuit Diagram on page [125](#) for wiring details.

## Series A Fan Circuit Board Removal and Installation

### Remove the Series A Fan Circuit Board

1. Read the General Safety Precautions on page [10](#).
2. Remove power from the drive. See Remove Power from the Drive on page [48](#).
3. Remove the top terminal cover from the drive. See Remove the Protective Covers on page [51](#).

---

Mark all connections and wires before removal to avoid incorrect wiring during reassembly.

---

4. Loosen the screws that secure the plug-in terminal block at XE to the top of the fan circuit board and remove the terminal block.
5. Remove the plug-in terminal blocks at XF and XC from the fan circuit board.
6. Disconnect the ground wire from connector PE.
7. Remove the four hexalobular screws that secure the fan circuit board to the insulator and remove the board. Tightening torque is noted in the illustration for reassembly.

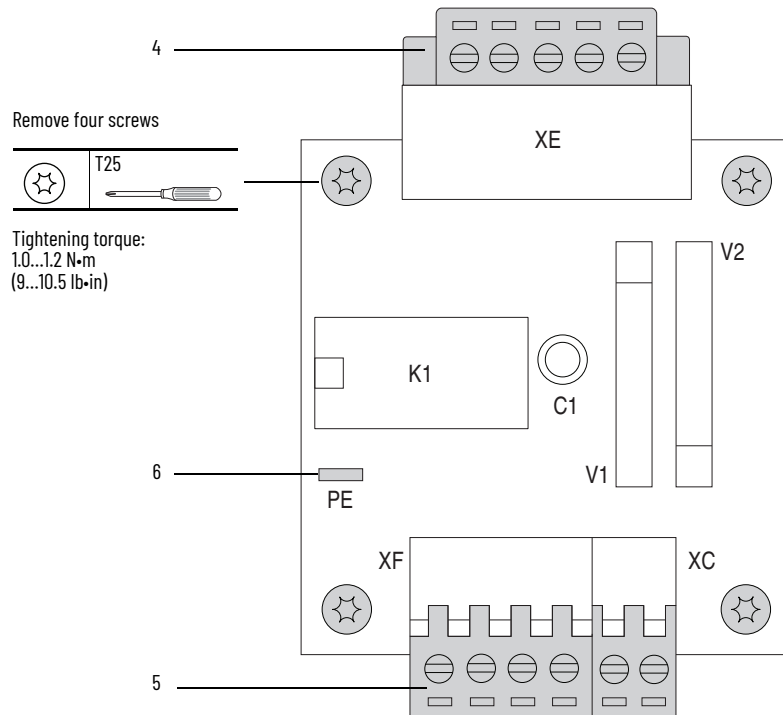

### Install the Series A Fan Circuit Board

Install the series A fan circuit board in the reverse order of removal. See the Series A Fan Circuit Diagram on page [125](#) for wiring details.

## Series B Fan Circuit Board Removal and Installation

### Remove the Series B Fan Circuit Board

1. Read the General Safety Precautions on page [10](#).
2. Remove power from the drive. See Remove Power from the Drive on page [48](#).
3. Remove the top terminal cover from the drive. See Remove the Protective Covers on page [51](#).
4. Remove the plug-in terminal block TB1 at XF2 from the fan circuit board.
5. Remove the plug-in terminal block TB2 at XF from the fan circuit board.
6. Remove the plug-in terminal block TB3 at XE from the fan circuit board.
7. Disconnect the ground wire from connector PE.
8. Remove the four hexalobular screws that secure the fan circuit board to the insulator and remove the board. Tightening torque is noted in the illustration for reassembly.

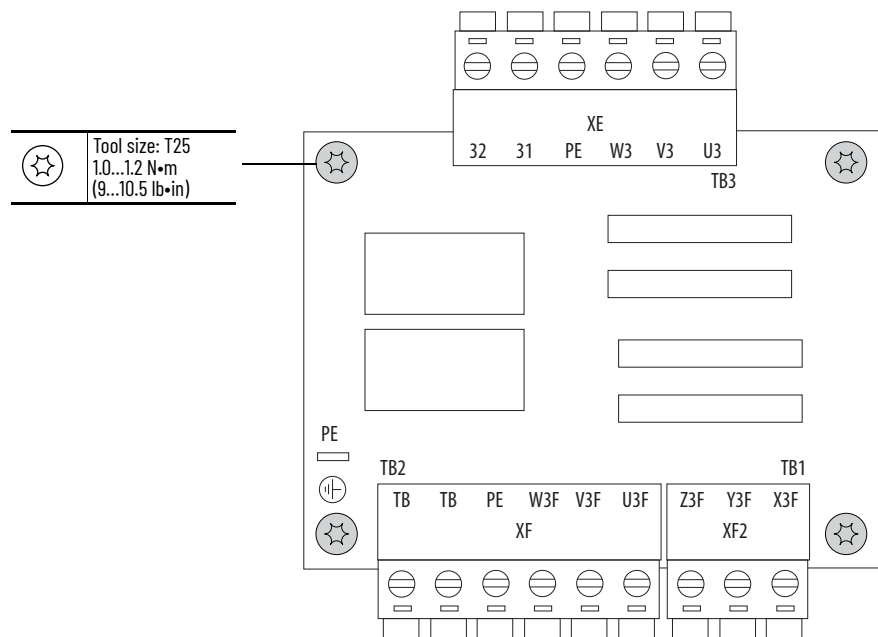

### Install the Series B Fan Circuit Board

Install the Series B fan circuit board in the reverse order of removal. See the Series A Fan Circuit Diagram on page [125](#) for wiring details.

## Series A Fan Assembly Removal and Installation

### Remove the Series A Fan Assembly

1. Read the General Safety Precautions on page [10](#).
2. Remove power from the drive. See Remove Power from the Drive on page [48](#).
3. Remove the top terminal cover from the drive. See Remove the Protective Covers on page [51](#).
4. Loosen, but do not remove, the six hexalobular screws that secure the top airflow plate to the drive, then slide the plate forward to lift it off the screws.

Note: The airflow plate cannot be removed from the drive unless the AC input wiring and busbar extensions (if installed) are removed.

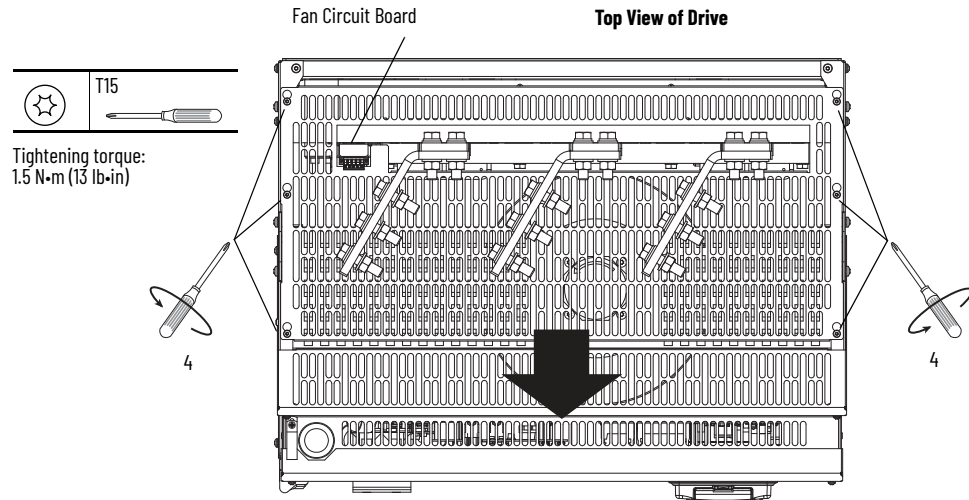

Mark all connections and wires before removal to avoid incorrect wiring during reassembly.

5. Remove the wires connected to the terminal block at XF on the fan circuit board (at the top of the drive, to the left of the fan blower). Cut the cable ties that secure the fan blower motor wires to the fan capacitor wires.

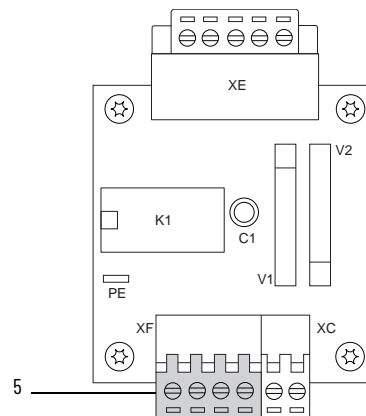

6. Using a 12.5 mm (0.5 in.) socket wrench, loosen the four nuts (two at each side) that secure the fan assembly bracket to the drive frame. To clear the fan blower inlet, lift the fan assembly bracket up and remove the bracket and fan assembly from the drive.



**ATTENTION:** The edges of the blades on the fan blower may be sharp. Take precautions to protect against personal injury when handling the fan assembly.

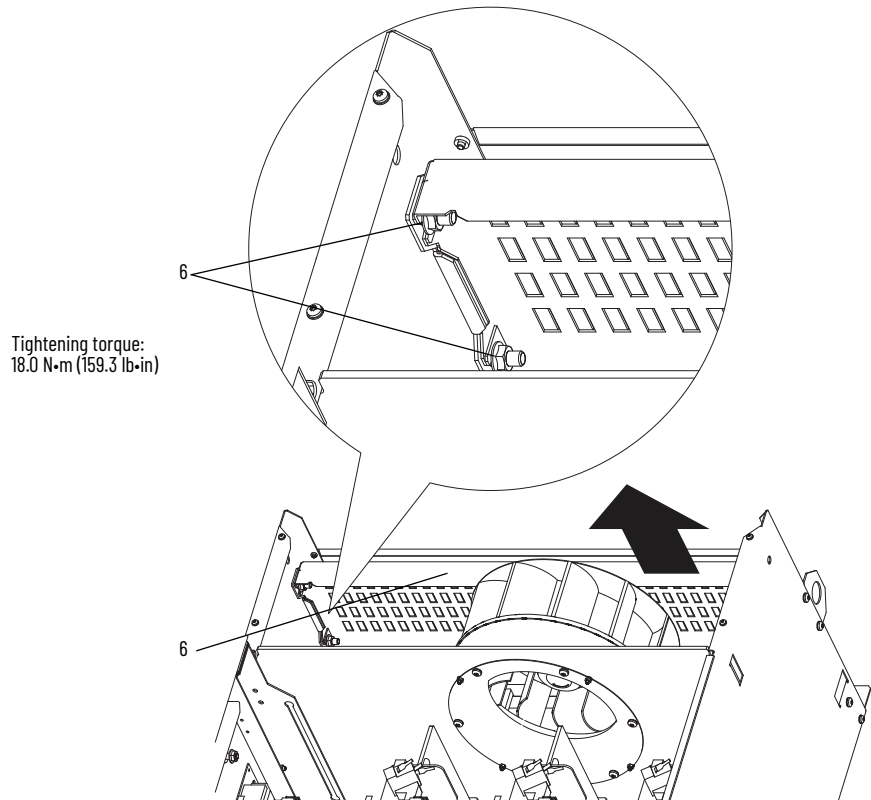

### Install the Series A Fan Assembly

Install the series A fan assembly in the reverse order of removal. See the Series A Fan Circuit Diagram on page [125](#) for wiring details.

Secure the fan power wires using cable ties, as previously installed, to make sure that the wires do not make contact with moving parts.

## Series B Fan Assembly Removal and Installation

### Remove the Series B Fan Assembly

1. Read the General Safety Precautions on page [10](#).
2. Remove power from the drive. See Remove Power from the Drive on page [48](#).
3. Remove the top terminal cover from the drive. See Remove the Protective Covers on page [51](#).
4. Loosen, but do not remove, the six hexalobular screws that secure the top airflow plate to the drive, then slide the plate forward to lift it off the screws.

**Note:** The airflow plate cannot be removed from the drive unless the AC input wiring and busbar extensions (if installed) are removed.

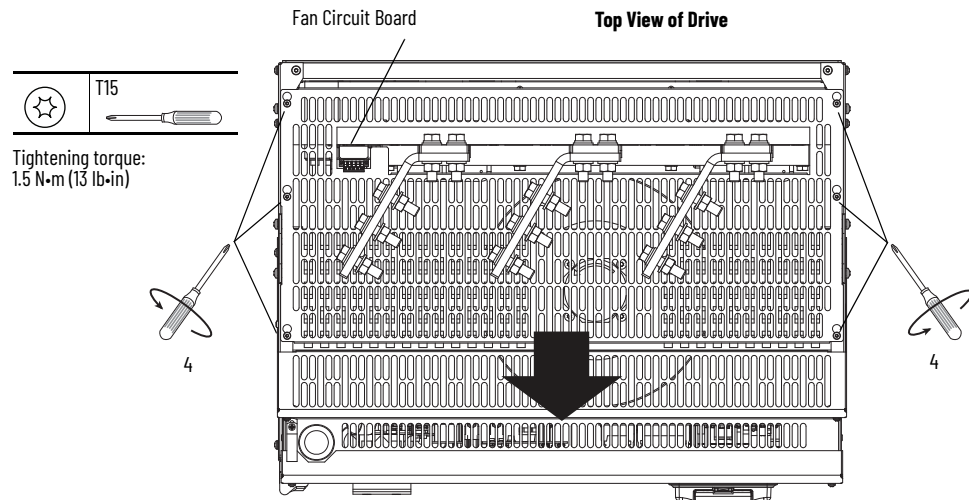

Mark all connections and wires before removal to avoid incorrect wiring during reassembly.

5. Remove the wires connected to terminal block TB1 at XF2 on the fan circuit board (at the top of the drive, to the left of the fan blower).

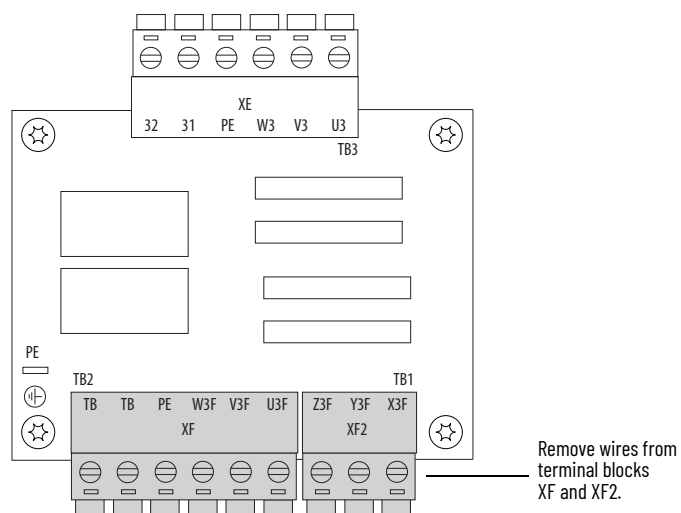

6. Using a 12.5 mm (0.5 in.) socket wrench, loosen the four nuts (two at each side) that secure the fan assembly bracket to the drive frame. To clear the fan blower inlet, lift the fan assembly bracket up and remove the bracket and fan assembly from the drive.



**ATTENTION:** The edges of the blades on the fan blower may be sharp. Take precautions to protect against personal injury when handling the fan assembly.

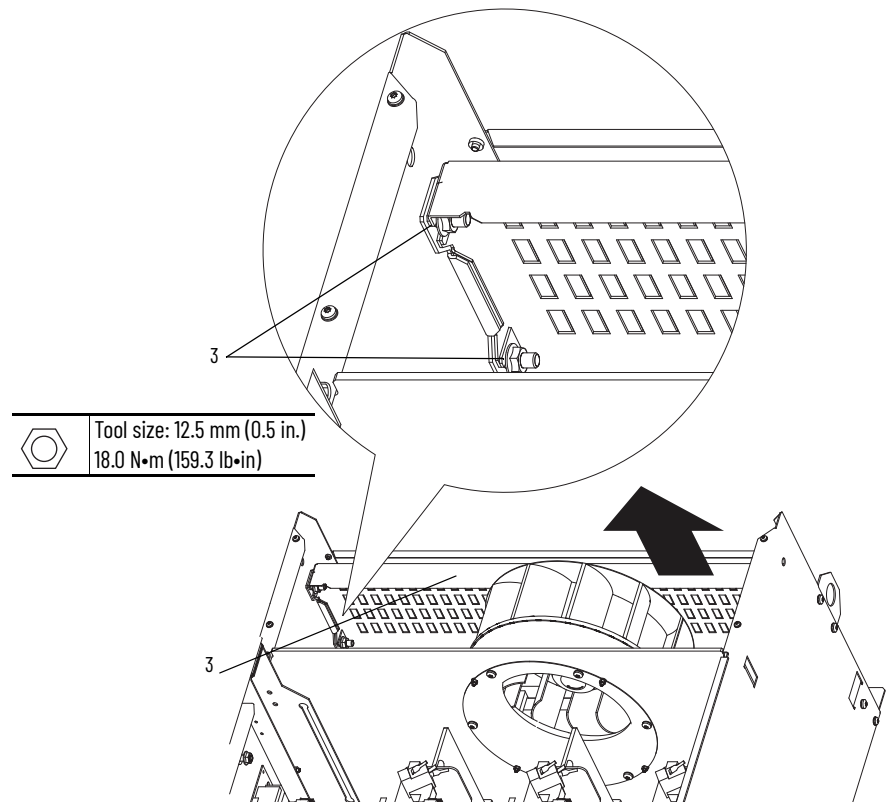

### Install the Series B Fan Assembly

Install the Series B fan assembly in the reverse order of removal. See the Series B Fan Circuit Diagram on page [126](#) for wiring details.

Secure the fan power wires using cable ties, as previously installed, to make sure that the wires do not make contact with moving parts.

## Series C Fan Assembly Removal and Installation

### Remove the Series C Fan Assembly

1. Read the General Safety Precautions on page [10](#).
2. Remove power from the drive. See Remove Power from the Drive on page [48](#).
3. Remove the top terminal cover from the drive. See Remove the Protective Covers on page [51](#).
4. Loosen, but do not remove, the six hexalobular screws that secure the top airflow plate to the drive. Slide the plate forward to lift it off the screws.

Note: The airflow plate cannot be removed from the drive unless the AC input wiring and busbar extensions (if installed) are removed.

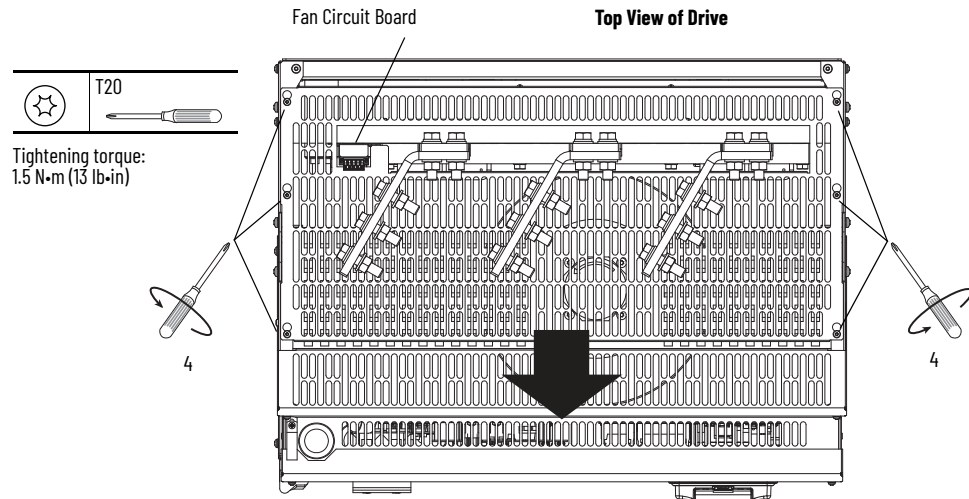

Mark all connections and wires before removal to avoid incorrect wiring during reassembly.

5. Remove the wires that are connected to the terminal blocks at XF and XF2 on the three-phase fan loss detection circuit board (at the top of the drive, to the left of the fan blower).

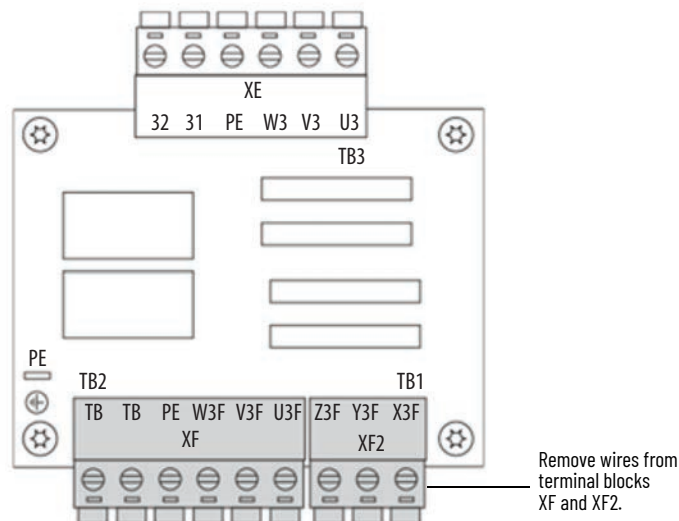

6. Use a 13 mm (0.51 in.) socket wrench to loosen the four nuts (two on each side) that secure the fan assembly bracket to the drive frame, and lift the fan assembly bracket up to clear the fan blower inlet. Remove the bracket and fan assembly from the drive.



**ATTENTION:** Edges of the fan blades can be sharp. Take precautions to help protect against personal injury when handling the fan assembly.

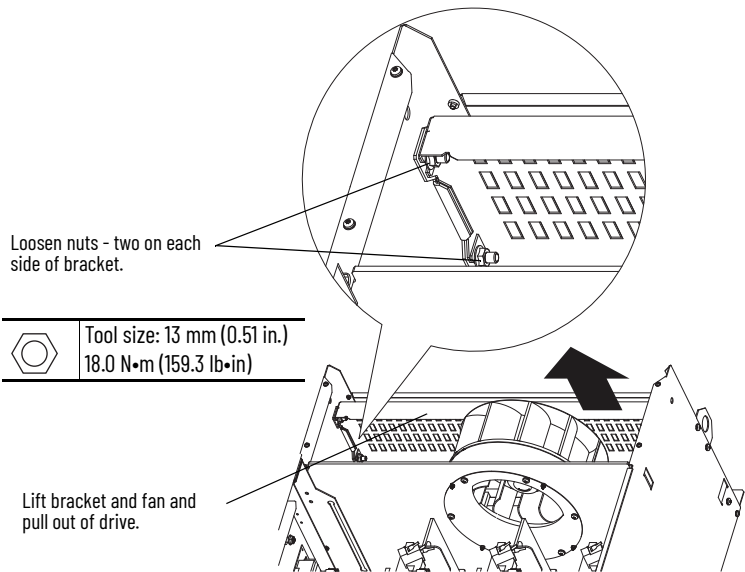

### Install the Series C Fan Assembly

Install the series C fan assembly in the reverse order of removal. See the Series C Fan Circuit Diagram on page [126](#) for wiring details.

The Frame D, series C drive cooling fan requires three-phase (50/60 Hz), 400...460V AC input power. If sourced from the main three-phase AC input, the power supply connections must be taken from the primary side of the installed isolation transformer or line reactor (clean power).

Secure the fan power wires using cable ties, as previously installed, to make sure that the wires do not make contact with moving parts.

## AC Current Transducers Removal and Installation

### Remove the AC Current Transducers

1. Read the General Safety Precautions on page [10](#).
2. Remove power from the drive. See Remove Power from the Drive on page [48](#).
3. Remove the top terminal cover from the drive. See Remove the Protective Covers on page [51](#).
4. Loosen, but do not remove, the six hexalobular screws that secure the top airflow plate to the drive, then slide the plate forward to lift it off the screws.

Note: The airflow plate cannot be removed from the drive unless the AC input wiring and busbar extensions (if installed) are removed.

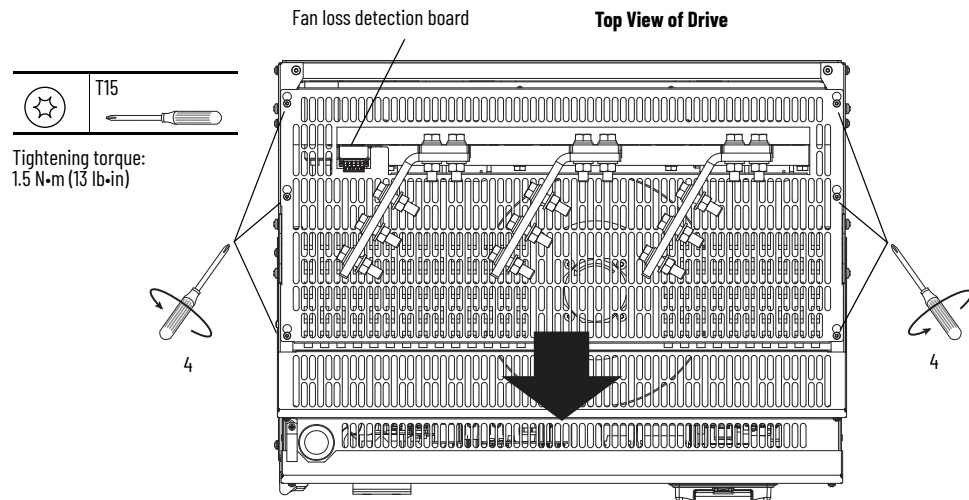

5. Open the control panel. See Open the Control Panel on page [53](#).

---

**IMPORTANT** Mark all connections and wires before removal to avoid incorrect wiring during reassembly.

---

6. The U and W phase AC input terminal busbars must be disconnected and pulled up in order to remove the AC current transducers. Remove the wiring from the U and W phase AC input terminal busbars, if necessary.
7. Remove the four bolts and washers that secure the top insulator bar, over the AC input terminal busbars, to the drive frame and remove the insulator bar.

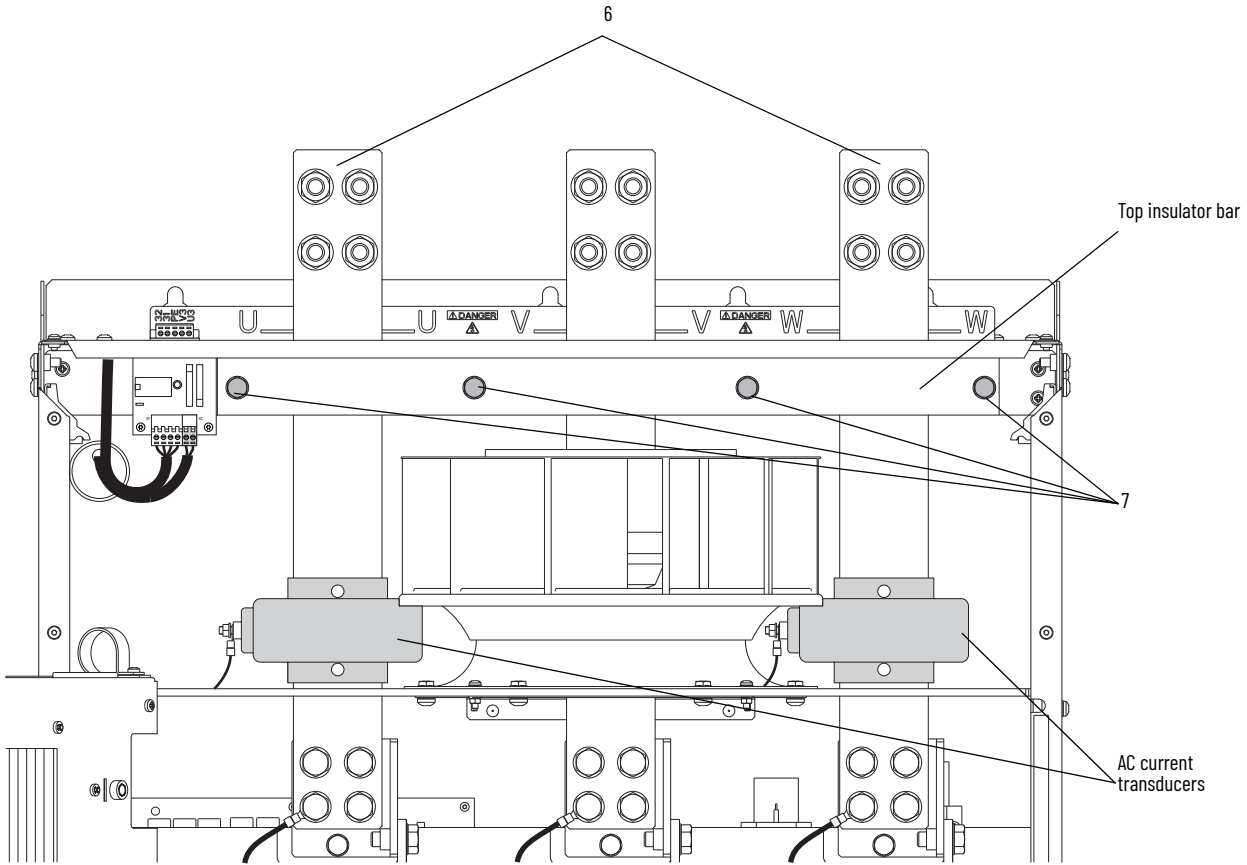

8. Remove the bolt and washer that secures each of the U and W phase AC input terminal busbars to the rear insulator bar.

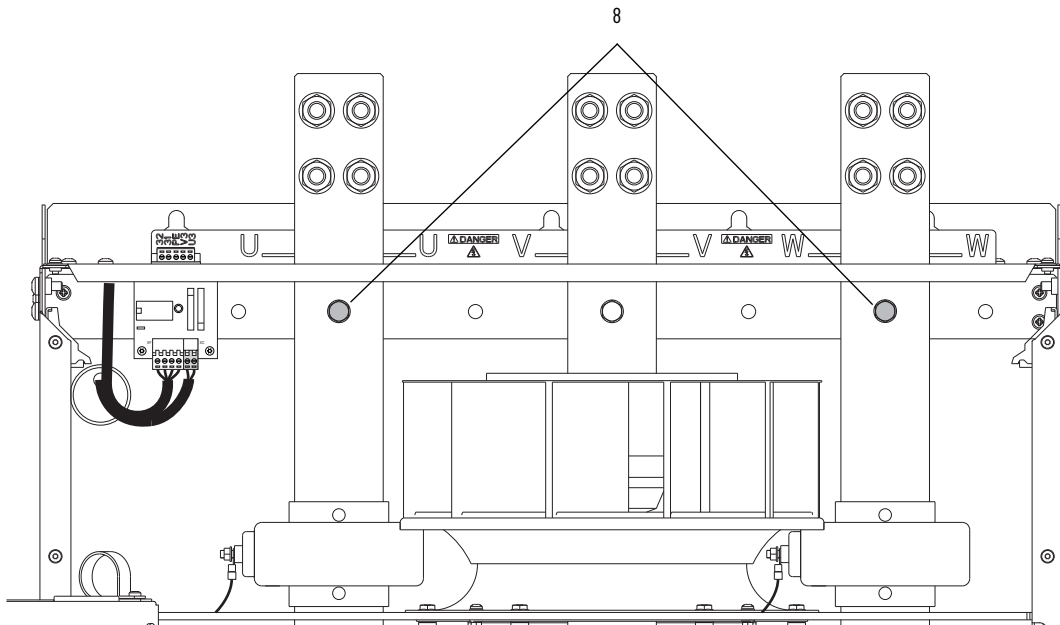

9. Remove the two nuts and washers that secure the signal wires to the terminals on each of the AC current transducers and remove the wires.
10. Loosen the two screws that secure each of the AC current transducers to the U and W phase terminal busbar, so that the current transducers are loose on the busbars.

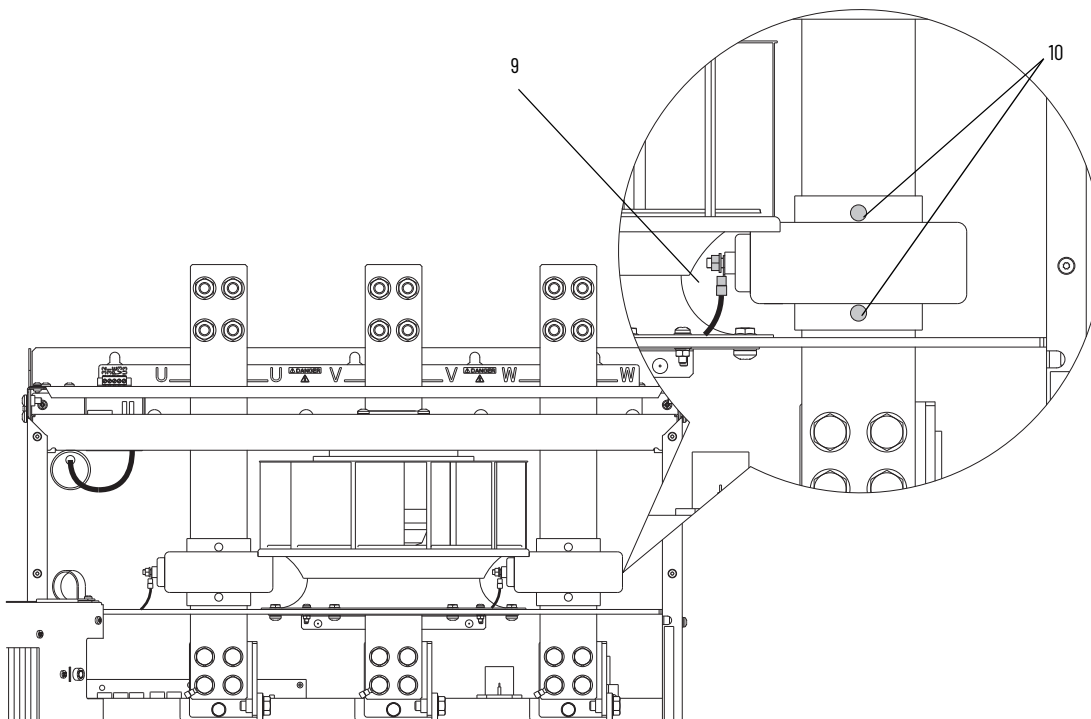

11. Remove the four M12 bolts and washers that secure each of the U and W phase AC input terminal busbars to the input busbars and carefully slide the terminal busbars up until the AC current transducers can be removed from the busbars.

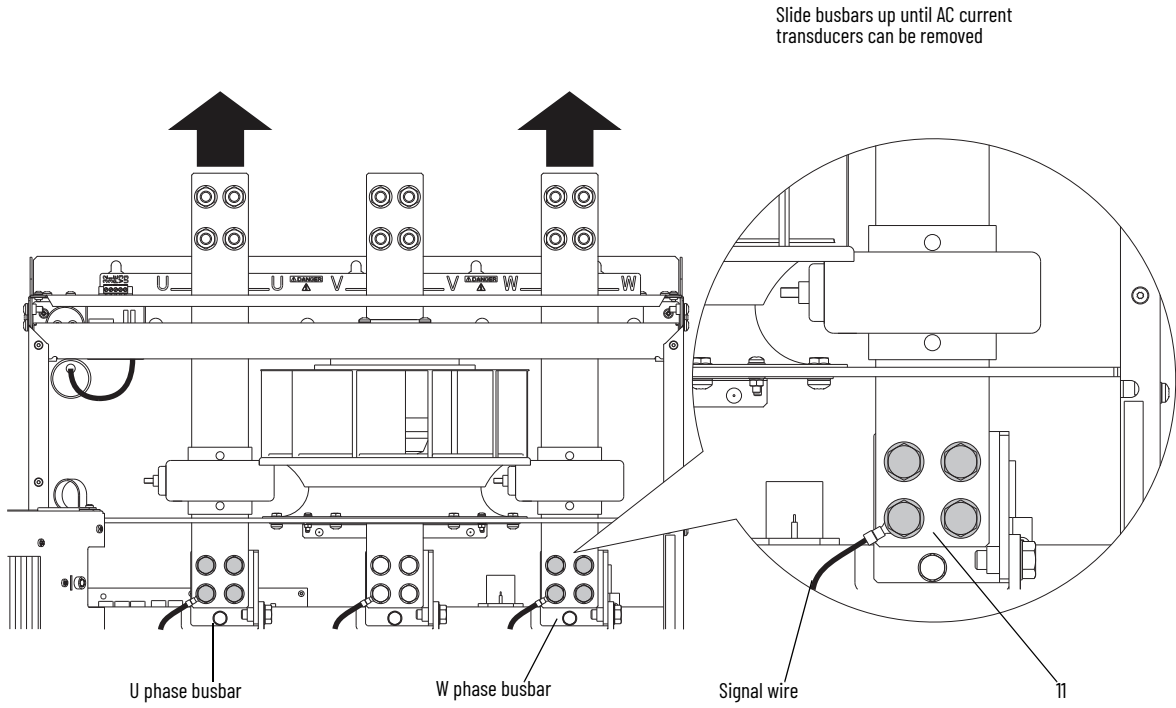

## Install the AC Current Transducers

Install the AC current transducers in reverse order of removal.

- Tightening torque for the M12 bolts is 45 N•m (398 lb•in).
- Verify that signal wire that was disconnected from the U and W phase busbars when removing the current transducers is reinstalled.

## Overvoltage Clipping Circuit Board Fuse Removal and Installation

### Remove the Overvoltage Clipping Circuit Board Fuses

1. Read the General Safety Precautions on page [10](#).
2. Remove power from the drive. See Remove Power from the Drive on page [48](#).
3. Open the control panel. See Open the Control Panel on page [53](#).
4. Remove the three fuses at locations F11, F21, and F31.

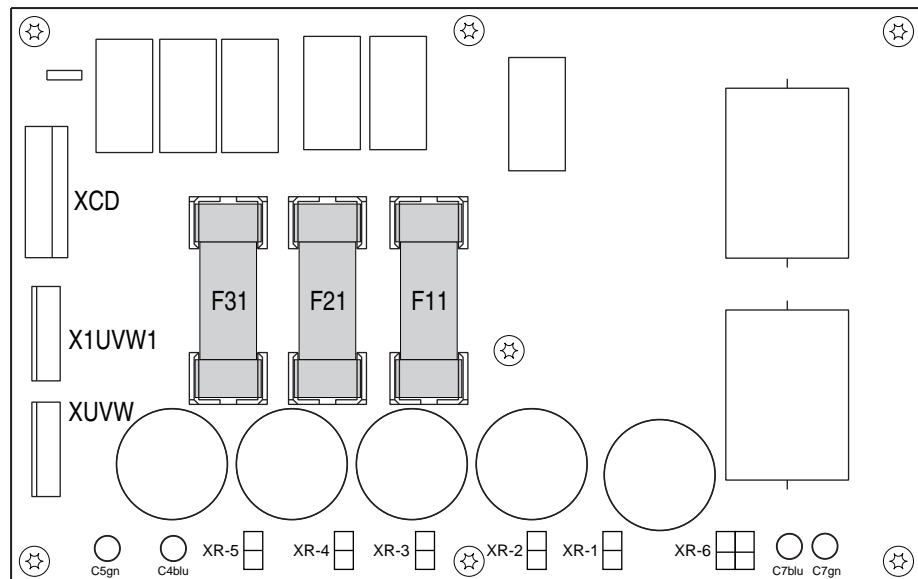

### Install the Overvoltage Clipping Circuit Board Fuses

Install the overvoltage clipping circuit board fuses in the reverse order of removal.

# Overvoltage Clipping Circuit Board Removal and Installation

1. Read the General Safety Precautions on page [10](#).
2. Remove power from the drive. See Remove Power from the Drive on page [48](#).
3. Open the control panel. See Open the Control Panel on page [53](#).

Mark all connections and wires before removal to avoid incorrect wiring during reassembly.

4. Disconnect the wires from connectors XCD, X1UVW1 and XUVW on the overvoltage clipping board.
5. Disconnect the resistor wires from connectors XR-1...XR-6 on the overvoltage clipping board. Note: On older boards, these connections are soldered directly to the board. In this case, unsolder the connections.
6. Remove the seven hexalobular screws and washers that secure the overvoltage clipping board to the drive frame and remove the board.

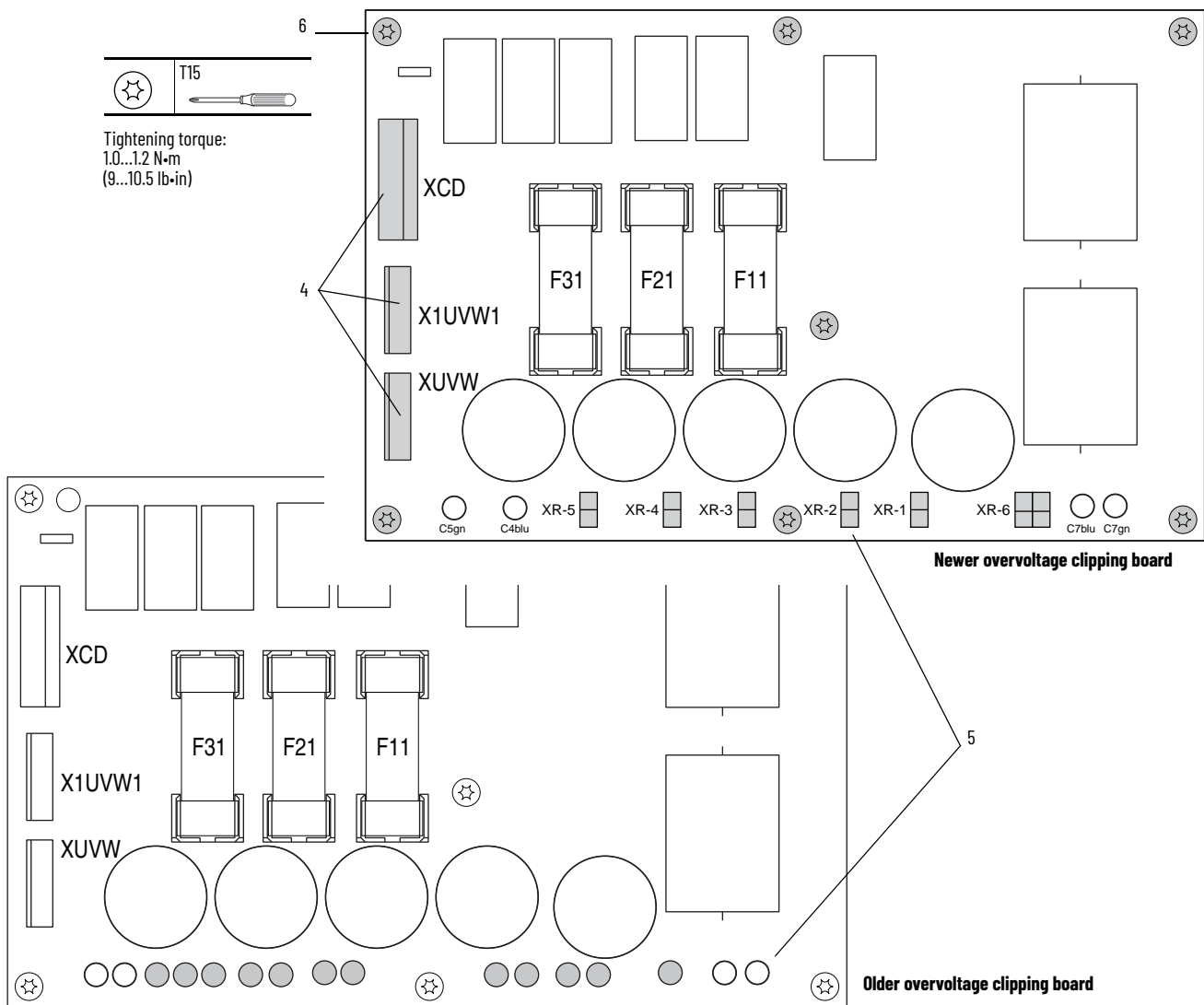

## Install the Overvoltage Clipping Circuit Board

Install the overvoltage clipping circuit board in the reverse order of removal.

### Armature Leg Fuse Removal and Installation

#### Remove the Armature Leg Fuse

1. Read the General Safety Precautions on page [10](#).
2. Remove power from the drive. See Remove Power from the Drive on page [48](#).
3. Open the control panel. See Open the Control Panel on page [53](#).

---

**IMPORTANT** Mark all connections and wires before removal to avoid incorrect wiring during reassembly.

---

4. Remove the screws that secure the switch to the fuse and remove the switch and fuse wires. Retain the switch, screws, and wires for reuse.

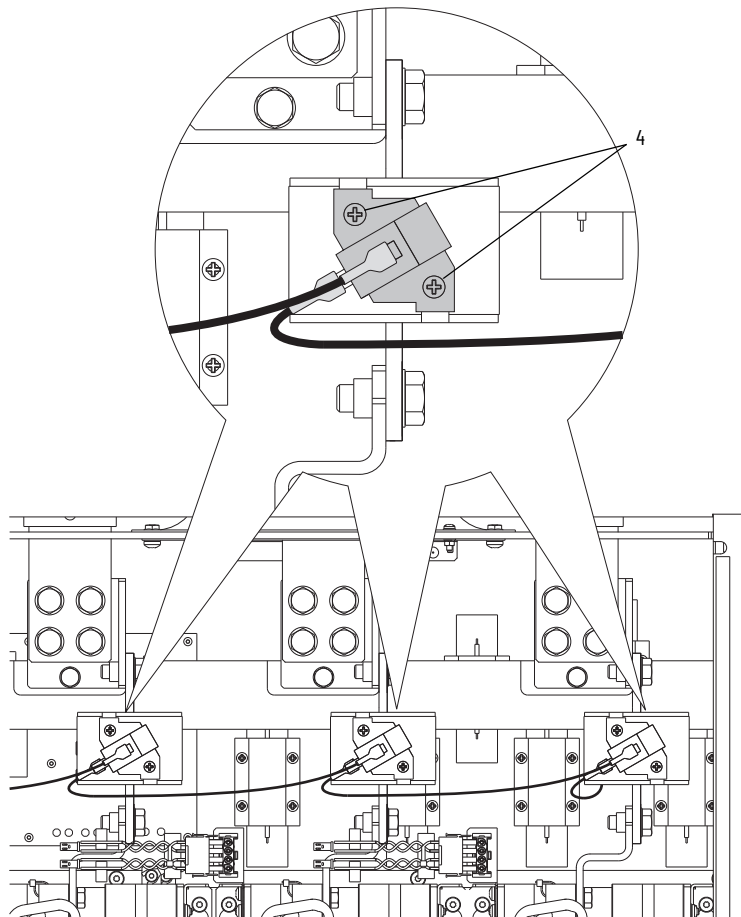

5. Loosen the two bolts that secure the fuse to the busbar and SCR leg terminal. Rotate the top of the fuse out and downward and pull the fuse off of the lower bolt and out of the drive.

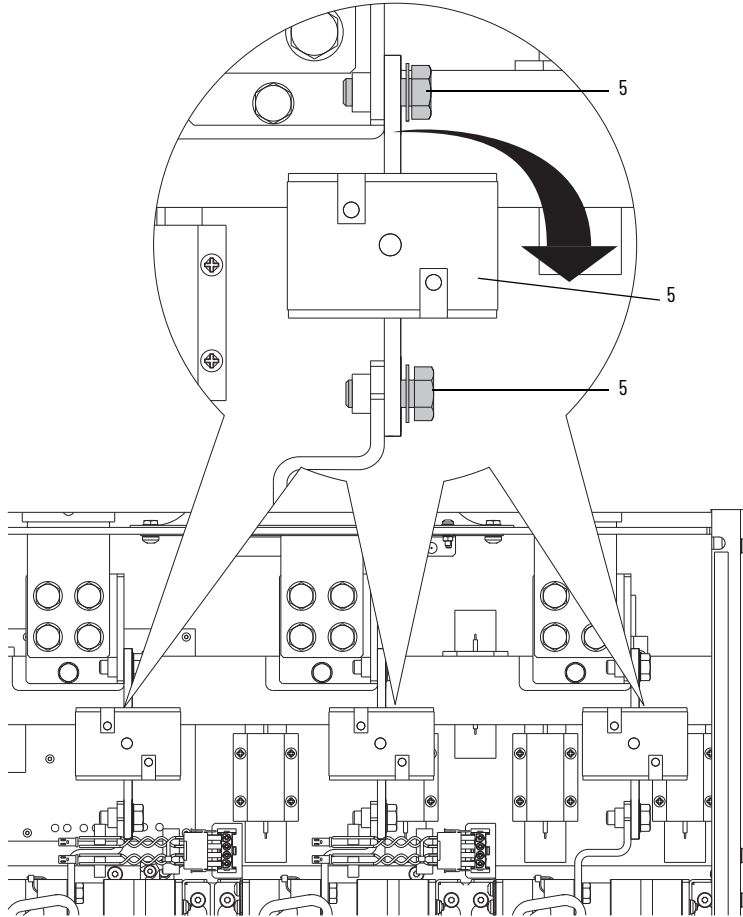

## Install the Armature Leg Fuse

Install the armature leg fuse in the reverse order of removal.

- Tightening torque for the fuse bolt is 45 N•m (398 lb•in).
- Install the existing fuse switch on the fuse body using the existing hardware. Verify that all wires are properly connected to the fuse switch.

## SCR Module Leg Assembly Removal and Installation

### Remove the SCR Module Leg Assembly

1. Read the General Safety Precautions on page [10](#).
2. Remove power from the drive. See Remove Power from the Drive on page [48](#).
3. Remove the bottom terminal cover from the drive. See Remove the Protective Covers on page [51](#).
4. Open the control panel. See Open the Control Panel on page [53](#).

---

**IMPORTANT** Note the terminal number on the fuse switch to which the signal wires are connected for proper reinstallation.

---

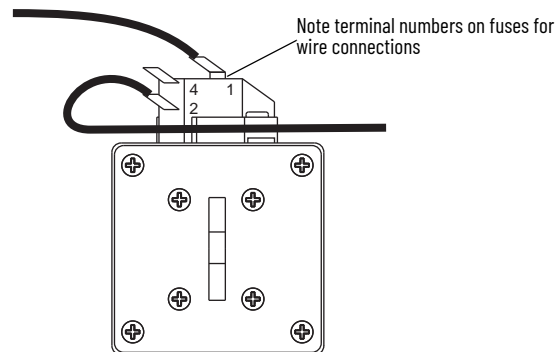

5. Remove the signal wires from the fuse switch connectors and secure the wires in a position above the input terminals.
6. Loosen the lower bolt and washer that secures the bottom of each leg fuse to the SCR module leg input terminal.
7. Loosen the upper bolt and washer that secures the top of the fuse to the AC input terminal, rotate the top of the fuse out and downward, and remove the fuse from the lower terminal.

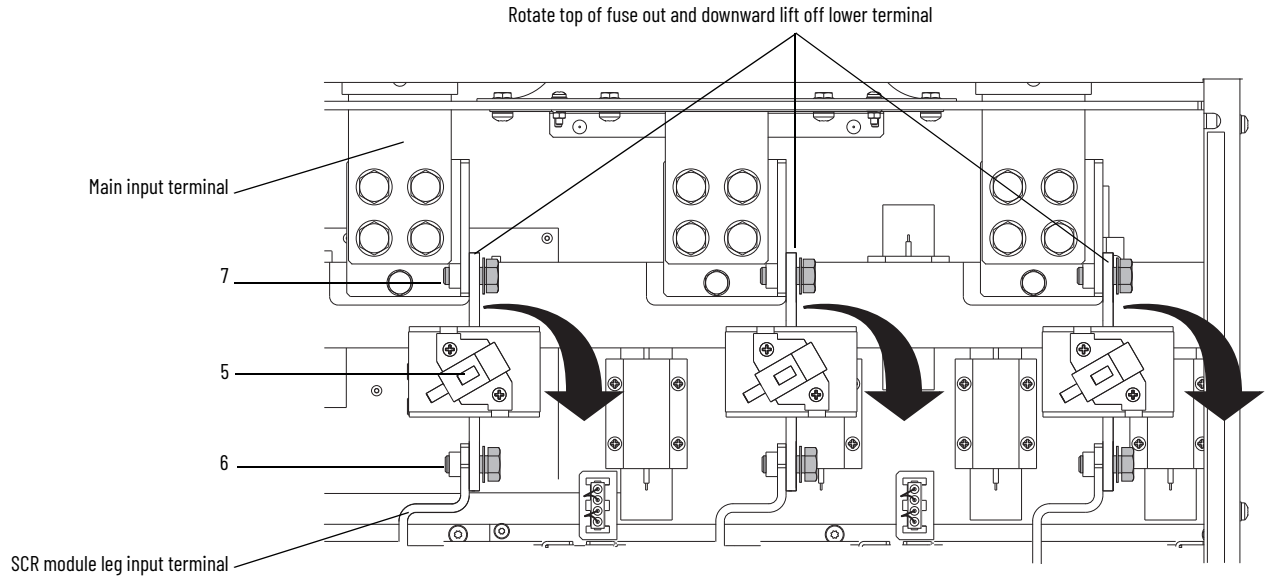

---

**IMPORTANT** Mark all connections and wires before removal to avoid incorrect wiring during reassembly.

---

8. Disconnect the gate lead wires from the connectors mounted at the top of each SCR module leg assembly. Note: there are three connectors at the front for non-regenerative drives. There are six connectors, three in front and three behind, for regenerative drives.
9. Disconnect the wires for the bimetal thermostat from the connector mounted on the middle of the left SCR module leg assembly.
10. Disconnect the wires for the capacitors and resistors from the connectors that are mounted at the bottom of each SCR module leg assembly.

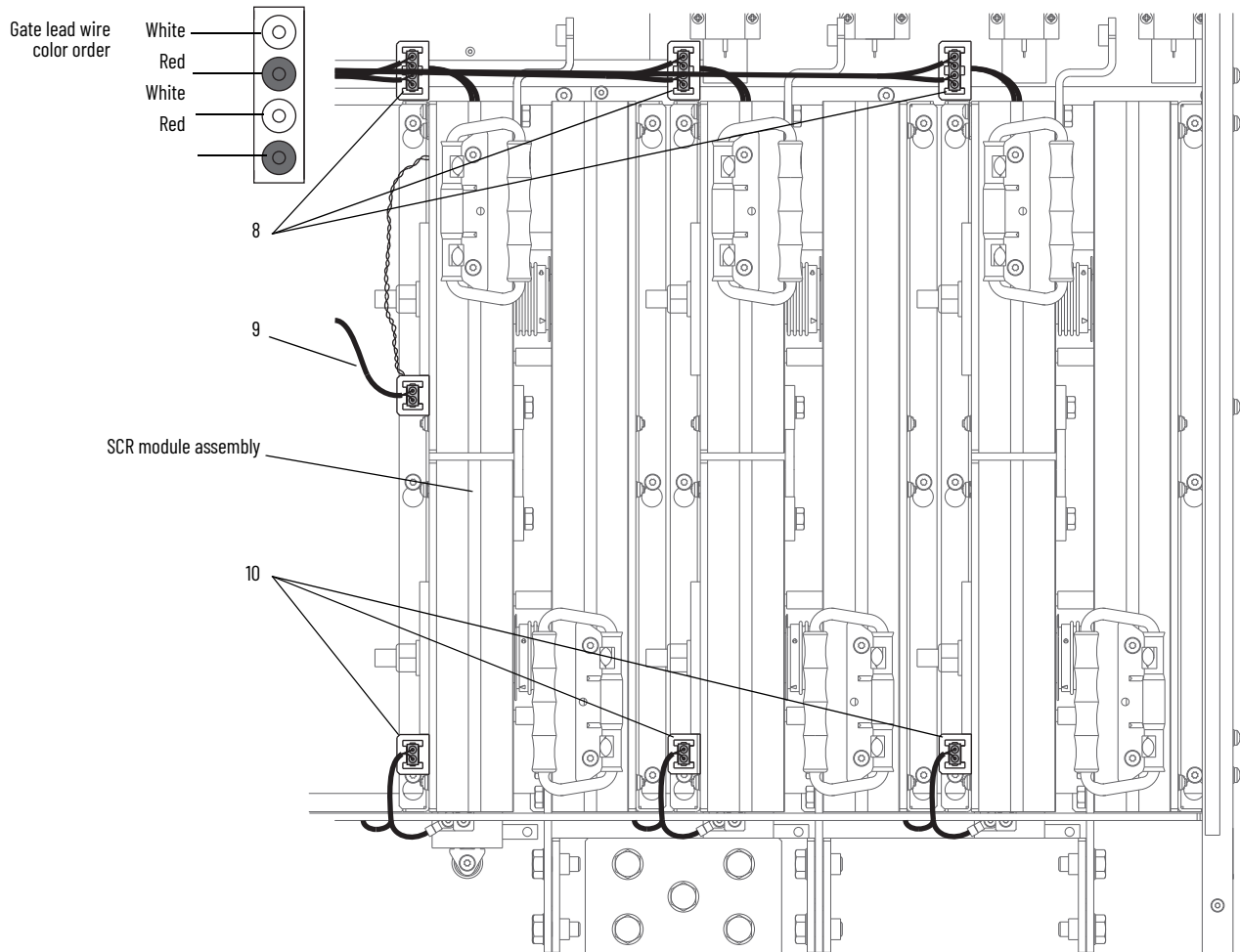

11. Remove the four bolts and washers that secure each SCR module leg assembly output terminal to a DC output busbar (C and D) at the bottom of the drive.

---

**IMPORTANT** Once the connecting bolts and washers are removed, the "C" shaped busbar between the middle and right SCR module leg assembly can be removed, allowing access to the rear terminals.

---

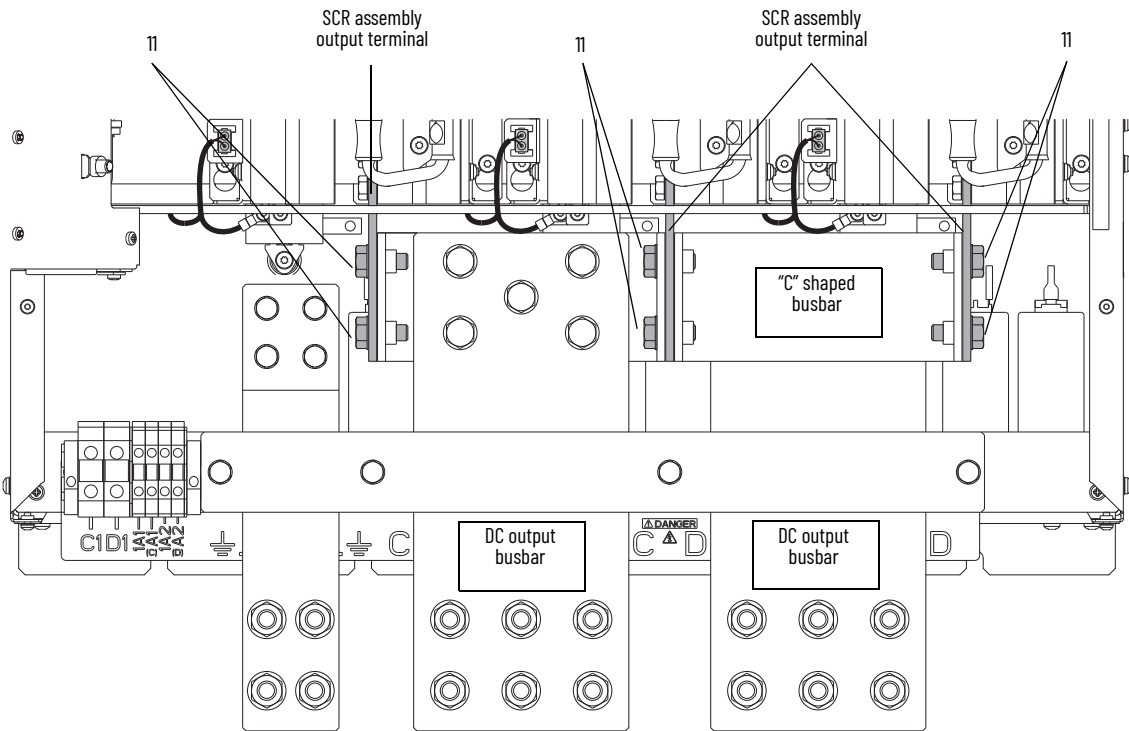

Angled view showing regenerative drive

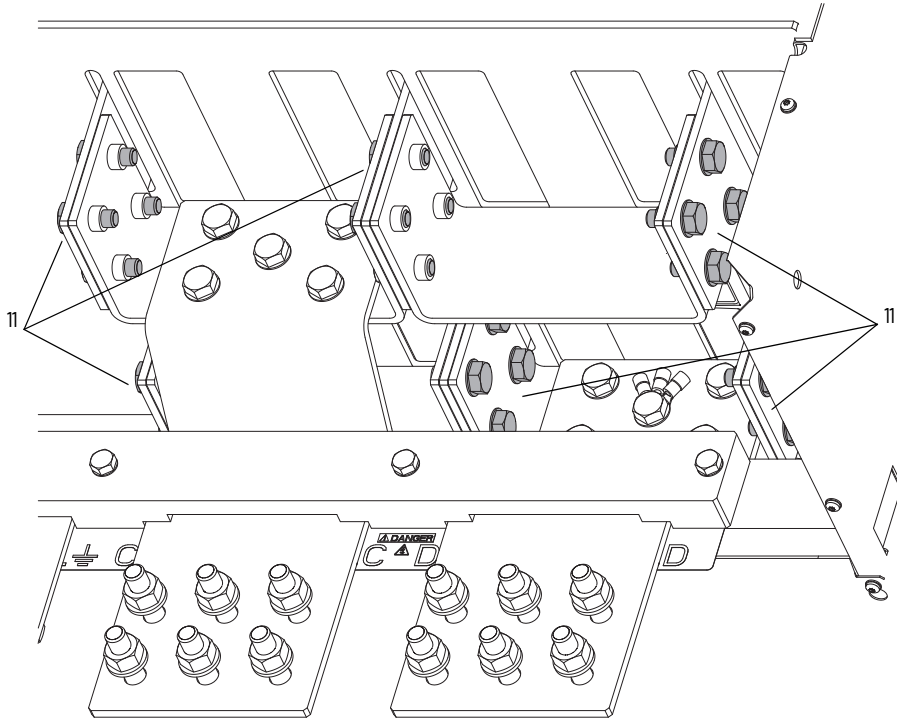

---

**IMPORTANT** Before removing the SCR assemblies, make sure that the area around the drive is clear of equipment. Only lift the assemblies using the handles provided.

---

12. Loosen the six hexalobular screws that secure the SCR module leg assembly to the back wall of the drive chassis.
13. Using the two handles, lift the SCR assembly up and off the mounting screws, and lift the assembly up and forward so that the output terminals clear the holes in the bottom of the drive frame.
14. Repeat steps 12 and 13 above for each SCR assembly.

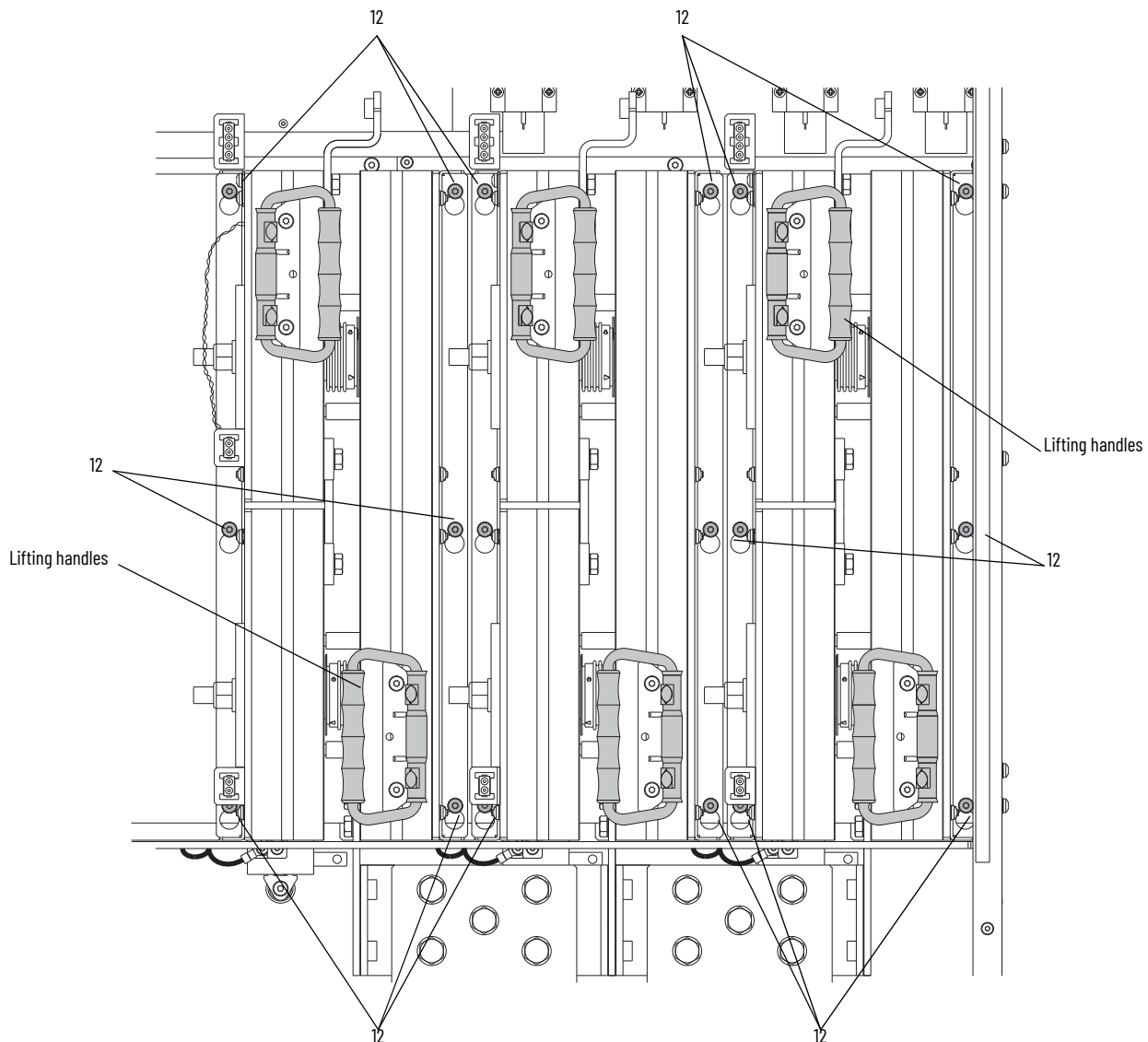

15. If you are reusing the bimetal thermostat that is mounted on the left SCR module leg assembly, disconnect the wires from the connector that is mounted on the middle, left-side of the assembly.
16. Remove the two hexalobular screws that secure the thermostat to the heatsink and remove the thermostat.

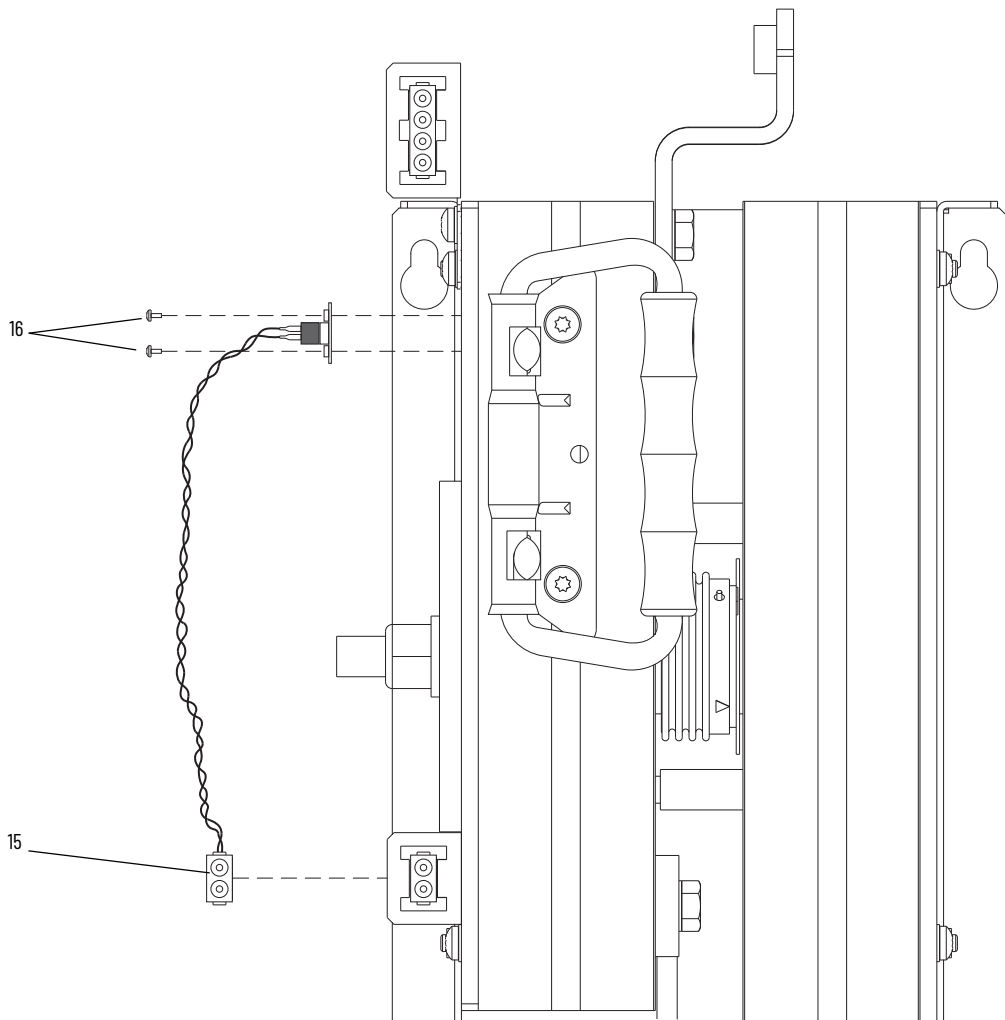

### Install the SCR Module Leg Assembly

Install the new SCR module leg assemblies in the reverse order of removal.

---

**IMPORTANT** Apply thermal grease to the bottom of the bimetal thermostat before installation.

---

- Tightening torque for the bimetal thermostat is 1.0 N•m (8.9 lb•in).
- Tightening torque for the SCR module leg assemblies is 4.5...5.0 N•m (40.0...44.4 lb•in).
- Tightening torque for the SCR module input and output terminals to the fuse terminals and DC output busbars is 45 N•m (398 lb•in).

## Bimetal Thermostat Removal and Installation

### Remove the Bimetal Thermostat

Note: The bimetal thermostat is mounted on the left SCR module leg assembly heatsink.

1. Read the General Safety Precautions on page [10](#).
2. Remove power from the drive. See Remove Power from the Drive on page [48](#).
3. Remove the bottom terminal cover from the drive. See Remove the Protective Covers on page [51](#).
4. Open the control panel. See Open the Control Panel on page [53](#).
5. Remove the left SCR module leg assembly from only the drive and remove the bimetal thermostat from the assembly heatsink. See Remove the SCR Module Leg Assembly on page [99](#).

### Install the Bimetal Thermostat

Install the new bimetal thermostat in the reverse order of removal.

## Discharge Resistors Removal and Installation

### Remove the Discharge Resistors

The discharge resistors are secured to the back wall of the drive frame behind the control panel.

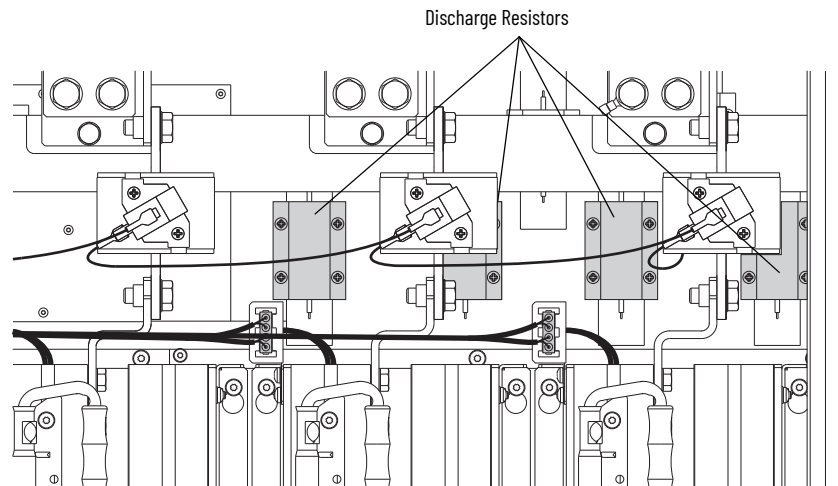

1. Read the General Safety Precautions on page [10](#).
2. Remove power from the drive. See Remove Power from the Drive on page [48](#).
3. Open the control panel. See Open the Control Panel on page [53](#).

---

**IMPORTANT** Mark all connections and wires before removal to avoid incorrect wiring during reassembly.

---

4. Disconnect the resistor wires from connectors XR-1...XR-6 on the overvoltage clipping board. Note: On older boards, these connections are soldered directly to the board. In this case, unsolder the connections.

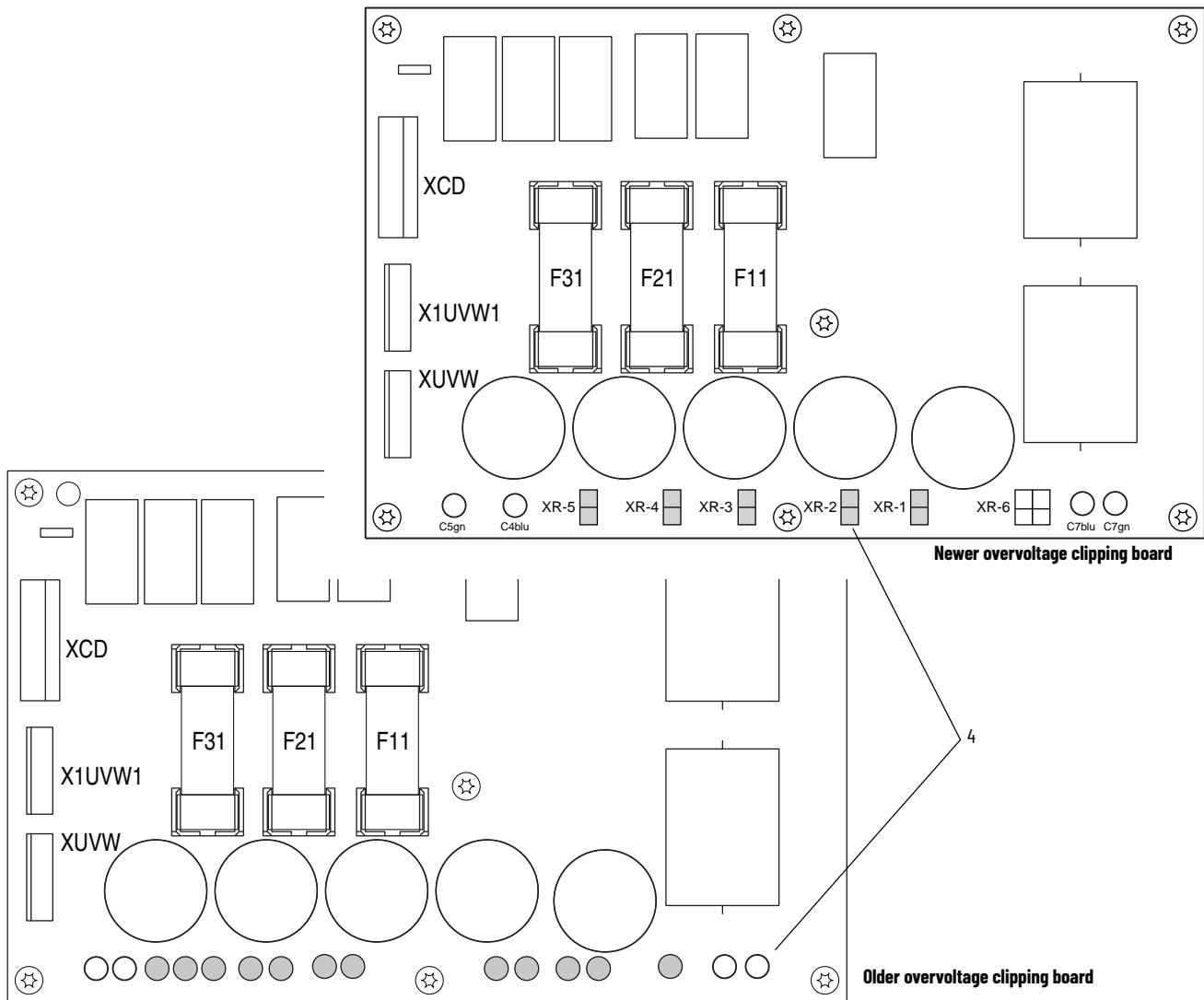

- Remove the four screws that secure each of the resistors to the drive frame and remove the resistors and wires.

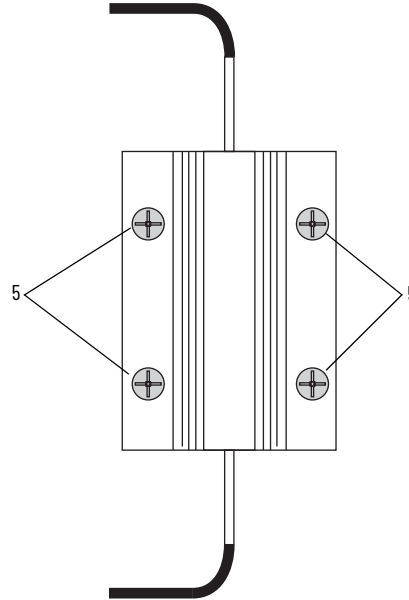

### Install the Discharge Resistors

Install the new discharge resistors in reverse order of removal.

## Inrush Limiting Resistor Removal and Installation

### Remove the Inrush Limiting Resistor

The inrush resistor is secured to the back wall of the drive frame below the control pan.

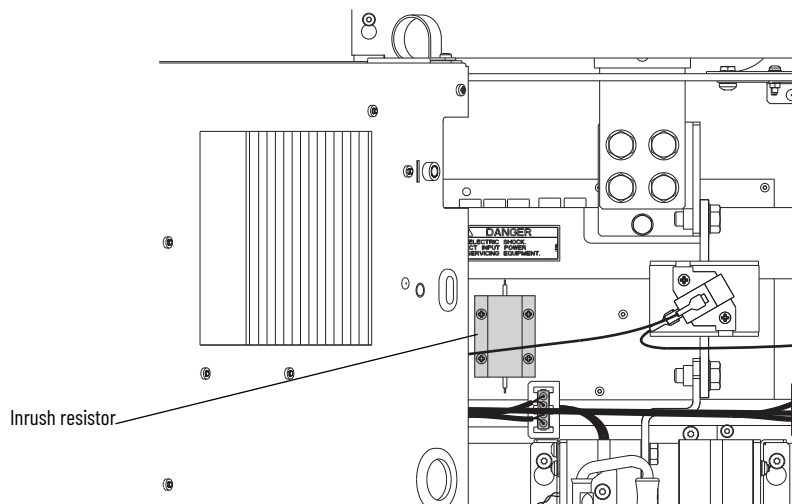

- Read the General Safety Precautions on page [10](#).
- Remove power from the drive. See Remove Power from the Drive on page [48](#).
- Open the control panel. See Open the Control Panel on page [53](#).

**IMPORTANT** Mark all connections and wires before removal to avoid incorrect wiring during reassembly.

4. Disconnect the resistor wires from connector XR-6 on the overvoltage clipping board.  
 Note: On older boards, these connections are soldered directly to the board. In this case, unsolder the connections.

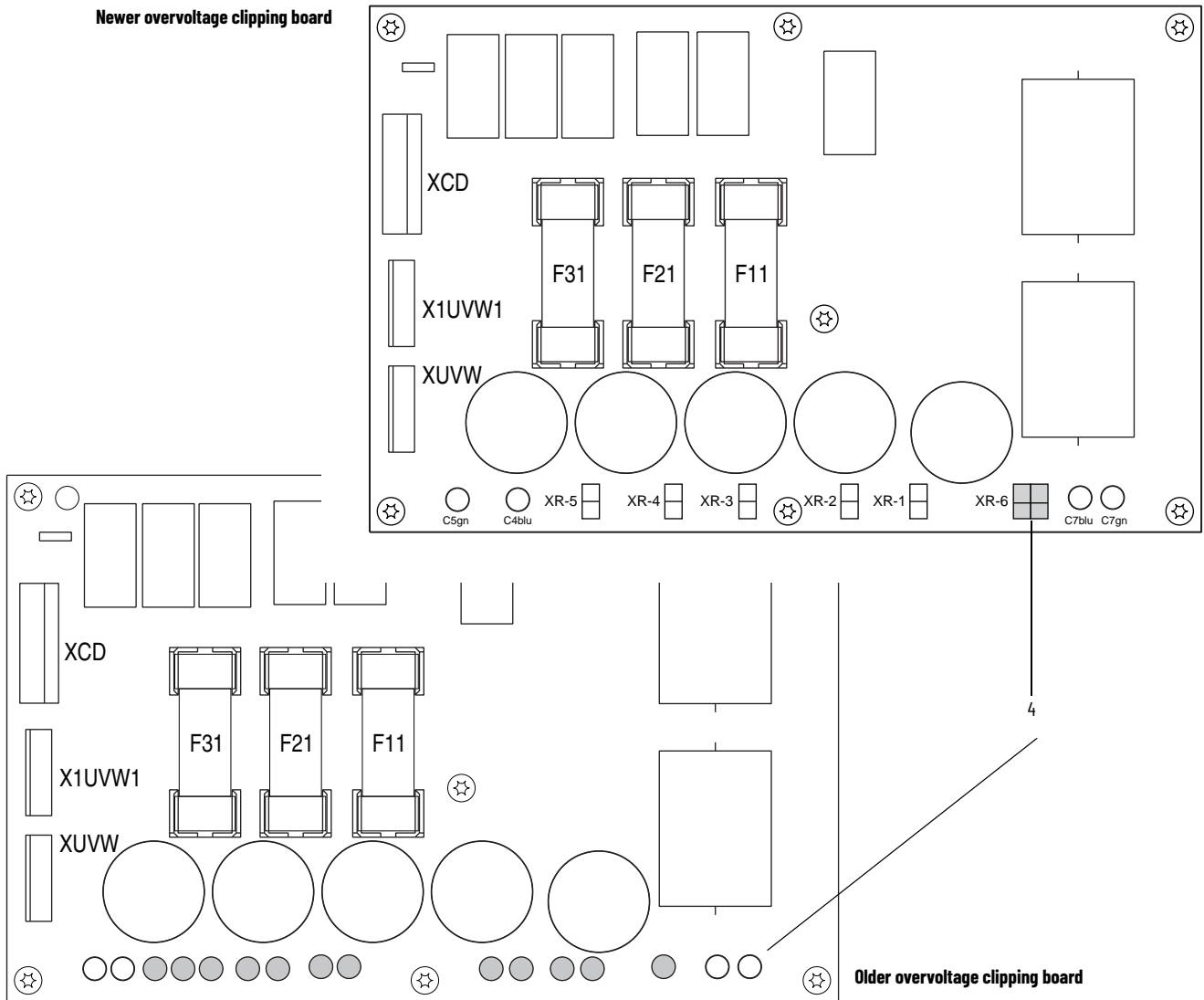

5. Remove the four screws that secure the resistor to the drive frame and remove the resistor and wires.

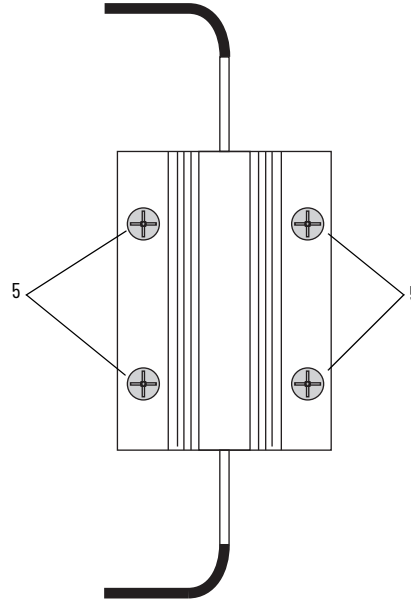

## Install the Inrush Limiting Resistor

Install the inrush limiting resistor in the reverse order of removal.

## Snubber Capacitors Removal and Installation

### Remove the Snubber Capacitors

1. Read the General Safety Precautions on page [10](#).
2. Remove power from the drive. See Remove Power from the Drive on page [48](#).
3. Remove the bottom terminal cover from the drive. See Remove the Protective Covers on page [51](#).
4. Remove the nut and washer that secures each of the snubber capacitors to the mounting bracket at the bottom of the drive chassis and lift the capacitors off the brackets.
5. Disconnect the wires from the top of each capacitor and remove the capacitors.

Note: Busbars shown removed for clarity only.

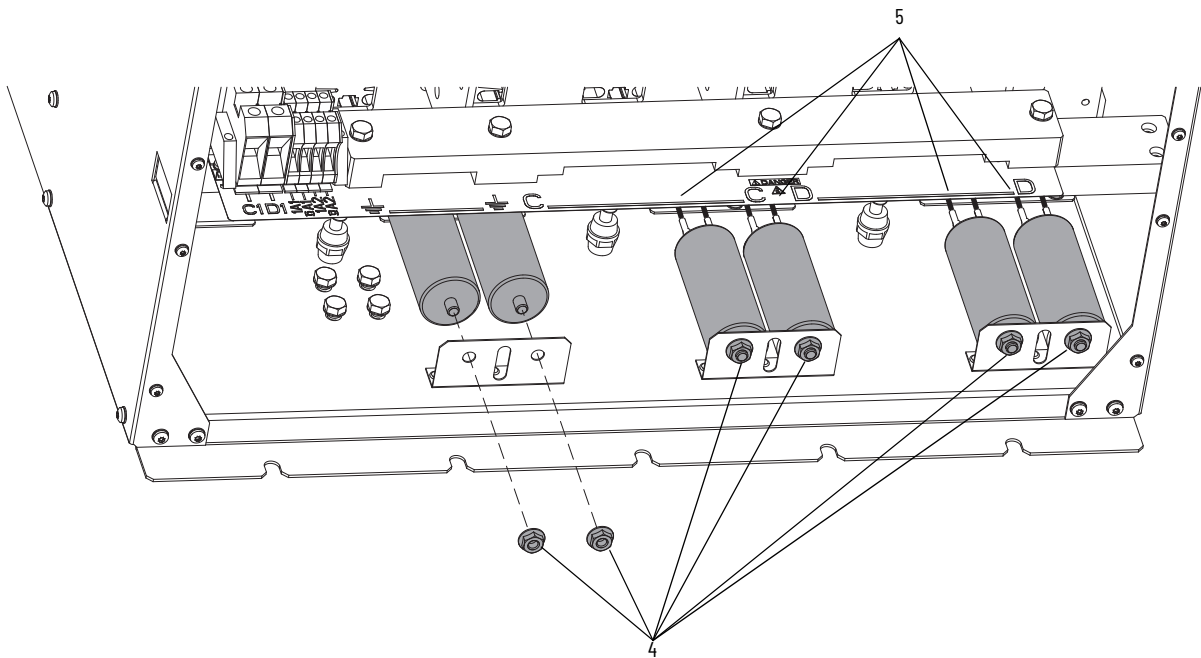

### Install the Snubber Capacitors

Install the snubber capacitors in the reverse order of removal.

## Snubber Resistors Removal and Installation

### Remove the Snubber Resistors

1. Read the General Safety Precautions on page [10](#).
2. Remove power from the drive. See Remove Power from the Drive on page [48](#).
3. Remove the bottom terminal cover from the drive. See Remove the Protective Covers on page [51](#).
4. Open the control panel. See Open the Control Panel on page [53](#).
5. Remove the SCR module leg assemblies from the drive. You do not need to remove the bimetal thermostat from the left SCR module assembly for this procedure. See Remove the SCR Module Leg Assembly on page [99](#).
6. Remove the 12 hexalobular screws and washers that secure the metal plate to the back wall of the drive chassis and remove the metal plate.

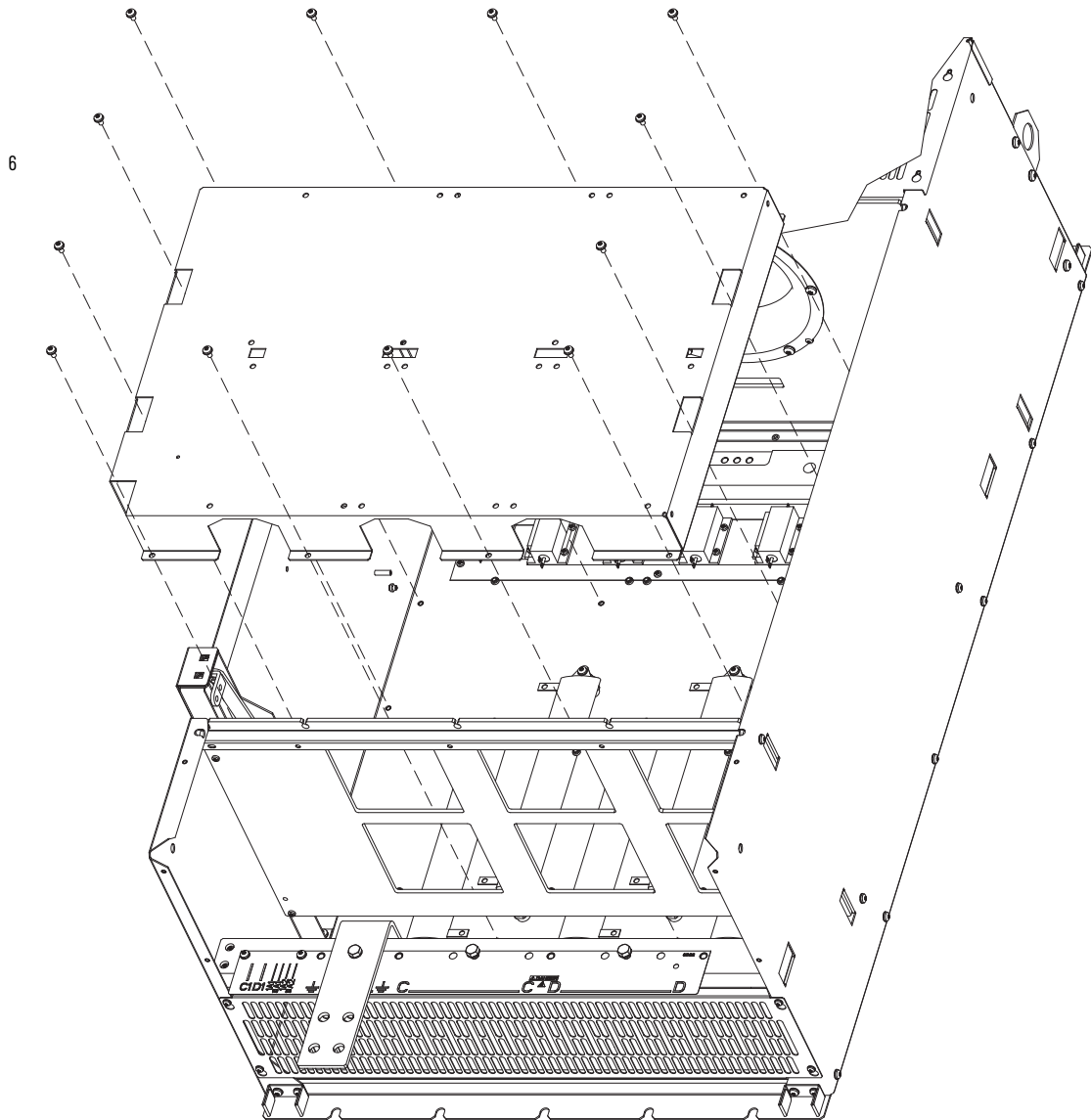

Note: Output terminals shown removed for clarity only.

7. Unsolder the wire leads from all resistor terminals. Retain the wires for reuse.

8. Remove the two hexalobular screws and washers that secure each of the snubber resistors to standoffs on the back wall of the drive chassis and remove the resistors.

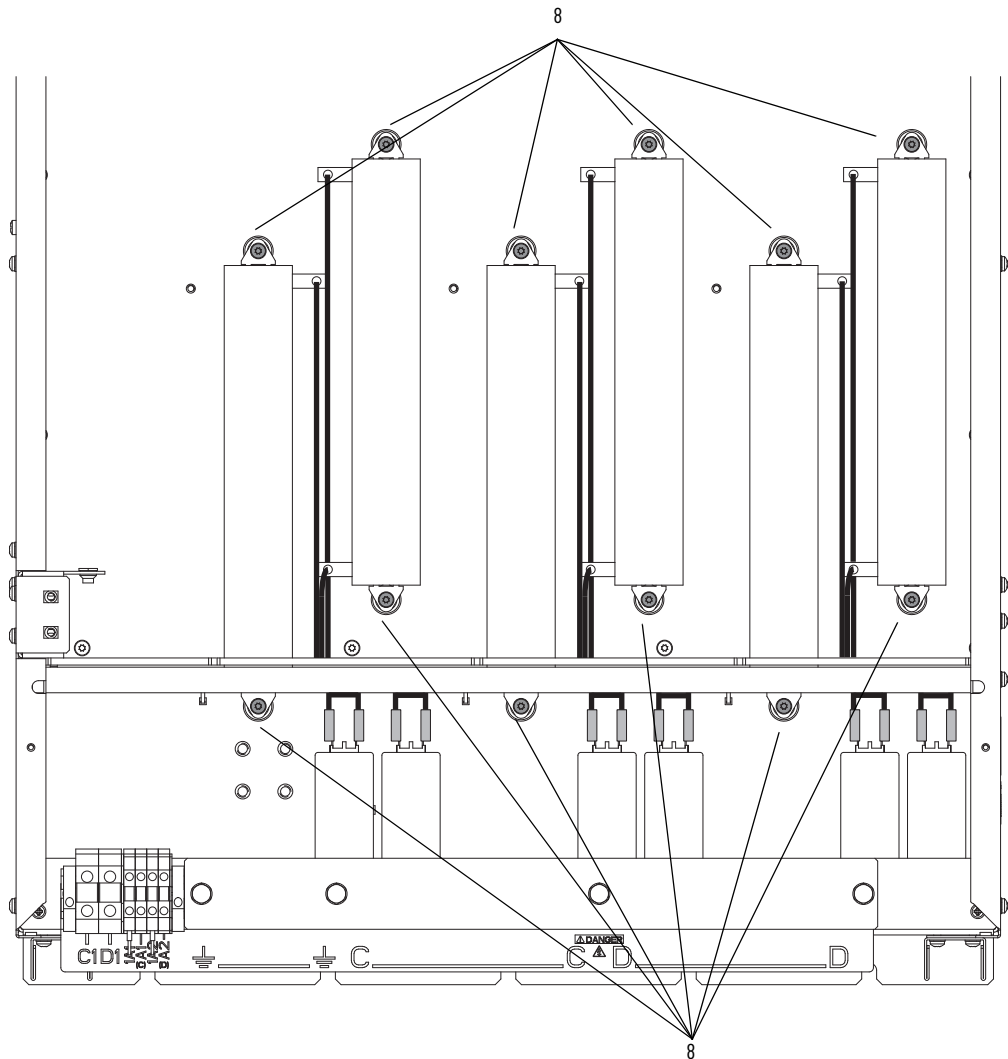

### Install the Snubber Resistors

Install the snubber resistors in the reverse order of removal.

## Start Up After Repair

Before applying power to a repaired drive, perform the following tests:

- Check the Armature SCR Modules on page [33](#)
- Check the Field SCR/Dual Diode Module on page [38](#)
- Complete the Test With the Motor, Without a Mechanical Load below.

### Test With the Motor, Without a Mechanical Load





This test allows you to measure several operating parameters and diagnose problems without connecting the motor to its mechanical load.

This procedure requires a HIM to configure and autotune the drive. If you prefer, you can use the Connected Components Workbench or DriveExecutive software.



**ATTENTION:** Power must be applied to the drive to perform the following start-up procedure. Some of the voltages present are at incoming line potential. To avoid electric shock hazard or damage to equipment, only qualified service personnel should perform the following procedure. Thoroughly read and understand the procedure before beginning. If an event does not occur while performing this procedure, **Do Not Proceed. Remove Power** including user supplied control voltages. User supplied voltages may exist even when main AC power is not applied to then drive. Correct the malfunction before continuing.

1. Verify that the input power wiring and grounding is connected.
2. Verify that the motor cables are connected.
3. Verify that the motor load is disconnected.
4. Verify that the control board DIP switches are set correctly. See Install the Control Circuit Board on page [70](#) for more information.
5. Apply power to the control circuits (terminals U2 and V2) of the drive.
6. Verify that the following parameter values are set correctly:
  - 45 [Max Ref Speed] is set to the motor nameplate base speed.
  - 162 [Max Feedback Spd] is set to the motor nameplate base speed.
  - 175 [Rated Motor Volt] is set to the motor rated nameplate armature voltage.
  - 179 [Nom Mtr Arm Amps] is set to the rated motor nameplate armature current.
  - 280 [Nom Mtr Fld Amps] is set to the rated motor nameplate field current.
  - 374 [Drv Fld Brdg Amps] is set to the rated current of the field bridge regulator
7. Energize the drive.
8. Measure the field current and verify that the value is reflected in parameter 234 [Fld Current Pct].
9. Run the following applicable Autotune procedures detailed in Chapter 2 of the TPDflex DC Converters User Manual, publication 1S7TFLEXUM0.
  - Tune the Current Regulator
  - Verify Motor Rotation Direction and Run Feedback Polarity Checks. If parameter 414 [Fdbk Device Type] is set to 3 "Armature", set parameter 107 [Speed Zero Level] to a minimum value of 10% of base motor speed.

- Configure the Speed Feedback Parameters
  - Tune the Speed Regulator
10. Make configuration changes that allow the HIM to issue start and speed commands.  

  11. Start the drive, by pressing  (the start button).  
If the drive will not start, verify that you have correctly installed any replacement components.  
If any faults are displayed on the HIM, refer to Chapter 4 - Troubleshooting in the TPDFlex DC Converters User Manual, publication 1S7TFLEXUMO.
  12. Increase the speed command from zero to base speed, by pressing  (the up button).
  13. Measure the output voltage and verify that it is reflected in parameter 233 [Output Voltage].
  14. Measure the armature current and verify that the value is reflected in parameter 199 [Arm Current Pct].
  15. Stop the drive, by pressing  (the stop button).
  16. If these measurements are correct, re-configure the drive to suit the application. Refer to Chapters 1 and 2 of the TPDFlex DC Converters User Manual, publication 1S7TFLEXUMO for assistance.

If any of these measurements are incorrect, repeat steps 8...15. If the measurements are still incorrect, repeat the appropriate procedures in Chapter 2 - Component Test Procedures beginning on page [13](#).

## Schematics

### List of Schematic Diagrams

<b>Topic</b>	<b>Page</b>
Figure 16 - Circuit Board Interconnection Diagram	116
Figure 17 - Block Diagram of Non-regenerative Drive Power Module with Six Fuses	117
Figure 18 - Block Diagram of Non-regenerative Drive Power Module with 12 Fuses	118
Figure 19 - Block Diagram of Regenerative Drive Power Module with Six Fuses	119
Figure 20 - Block Diagram of Regenerative Drive Power Module with 12 Fuses	120
Figure 21 - AC Line Measurement Points Diagram	121
Figure 22 - Power Feedback Connections Diagram	121
Figure 23 - Field Board and SCR/Dual Diode Module Connections Diagram	122
Figure 24 - Field Control Circuit Diagram	122
Figure 25 - Control Circuit Input Power Diagram	123
Figure 26 - Encoder Control Circuit Diagram	123
Figure 27 - DC Tachometer Control Circuit Diagram	124
Figure 28 - Motor Thermal Protection Control Circuit Diagram	124
Figure 29 - Drive Heatsink Monitoring Control Circuit Diagram	125
Figure 30 - Contactor Control Relays Control Circuit Diagram	125
Figure 31 - Series A Fan Circuit Diagram	125
Figure 32 - Series B Fan Circuit Diagram	126
Figure 32 - Series C Fan Circuit Diagram	126

Figure 16 - Circuit Board Interconnection Diagram

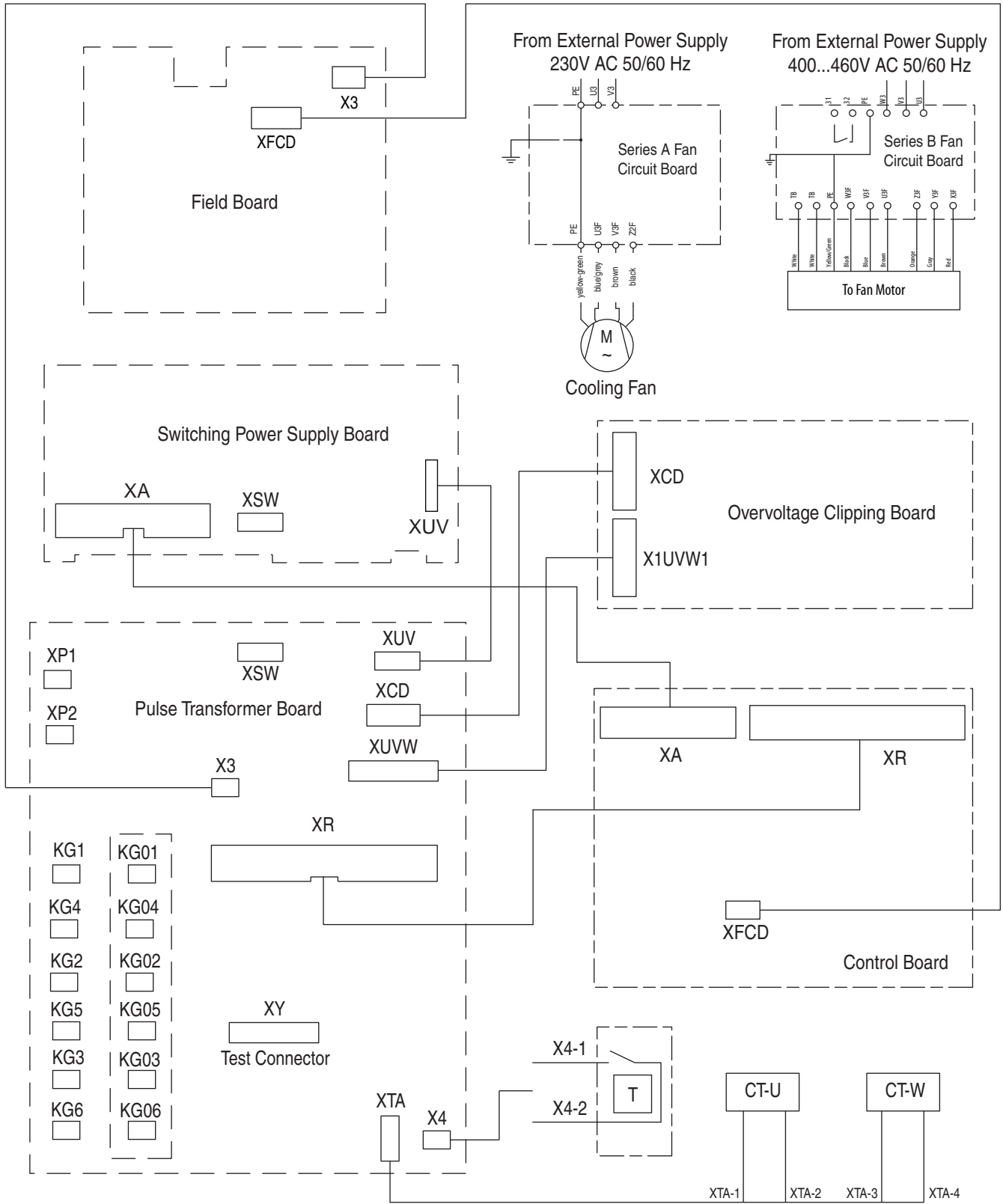

Figure 17 - Block Diagram of Non-regenerative Drive Power Module with Six Fuses

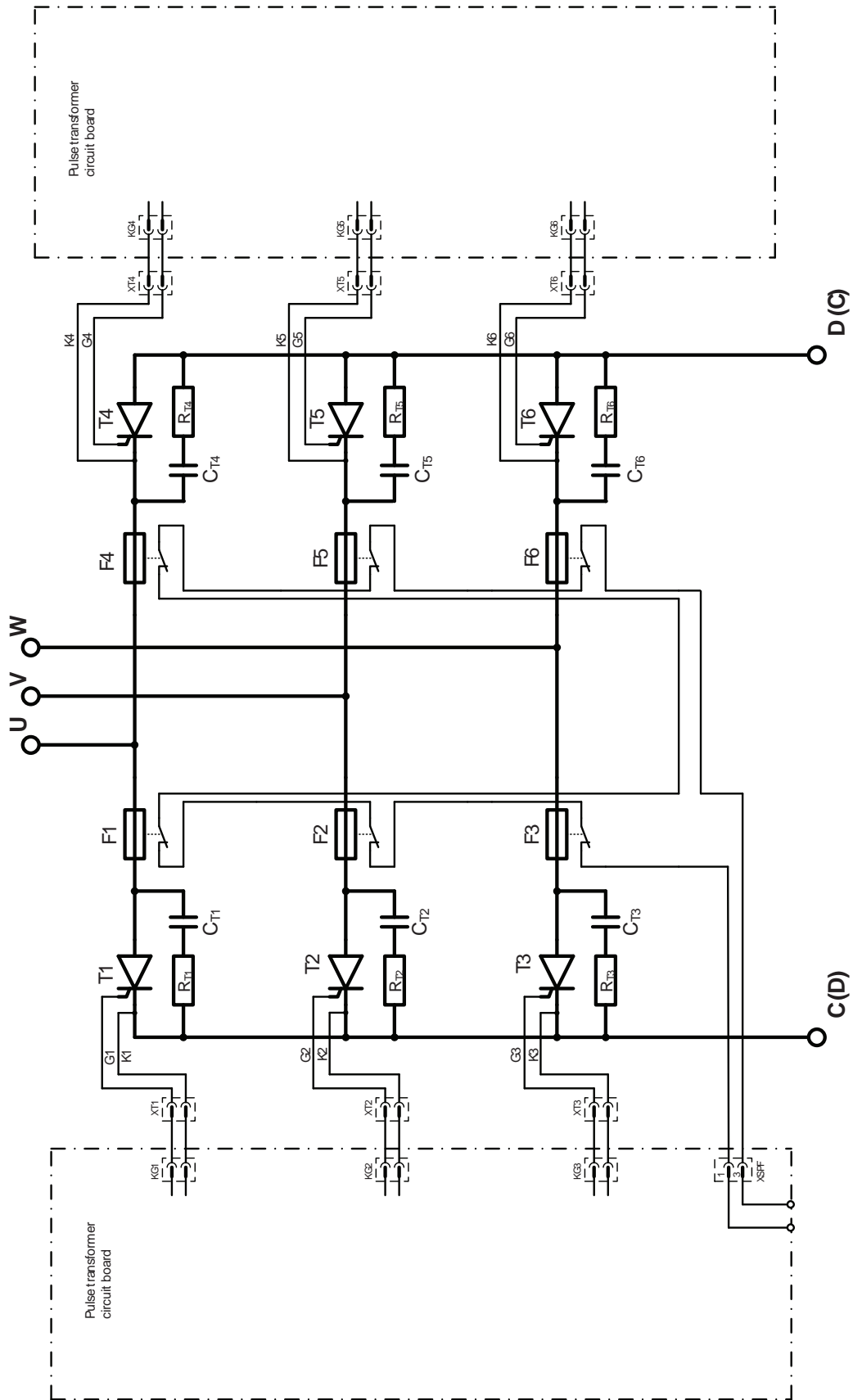

Figure 18 - Block Diagram of Non-regenerative Drive Power Module with 12 Fuses

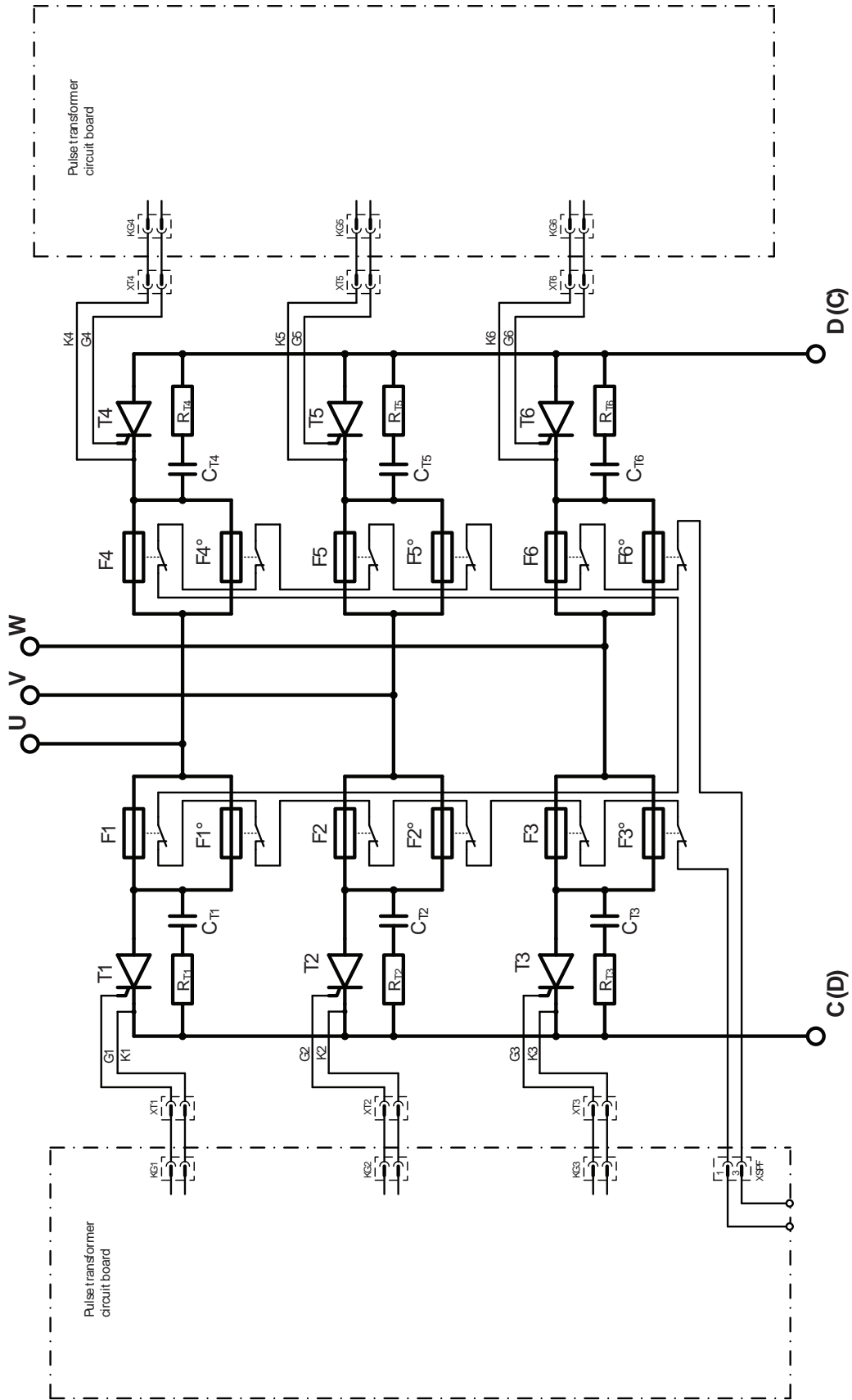

Figure 19 - Block Diagram of Regenerative Drive Power Module with Six Fuses

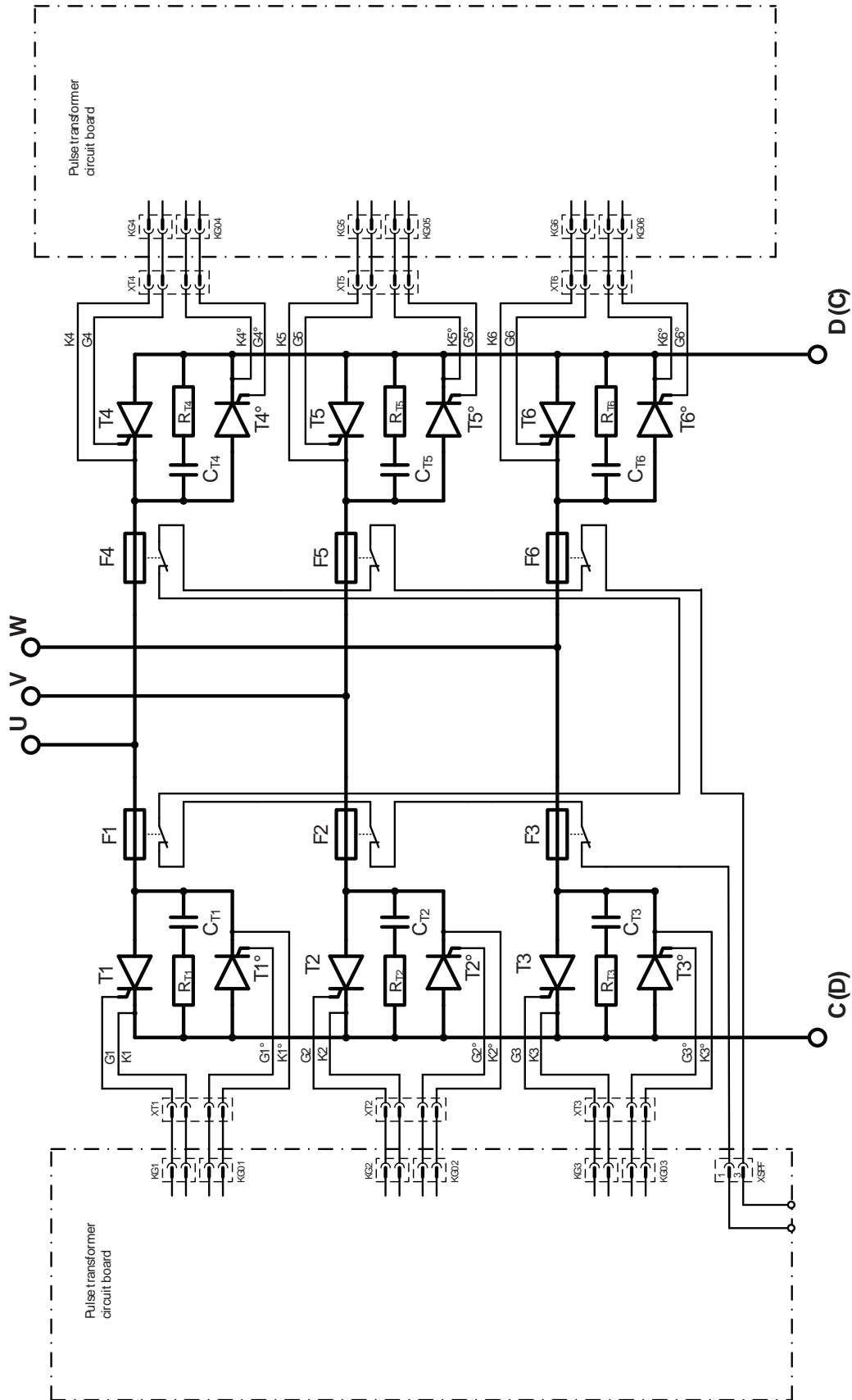

Figure 20 - Block Diagram of Regenerative Drive Power Module with 12 Fuses

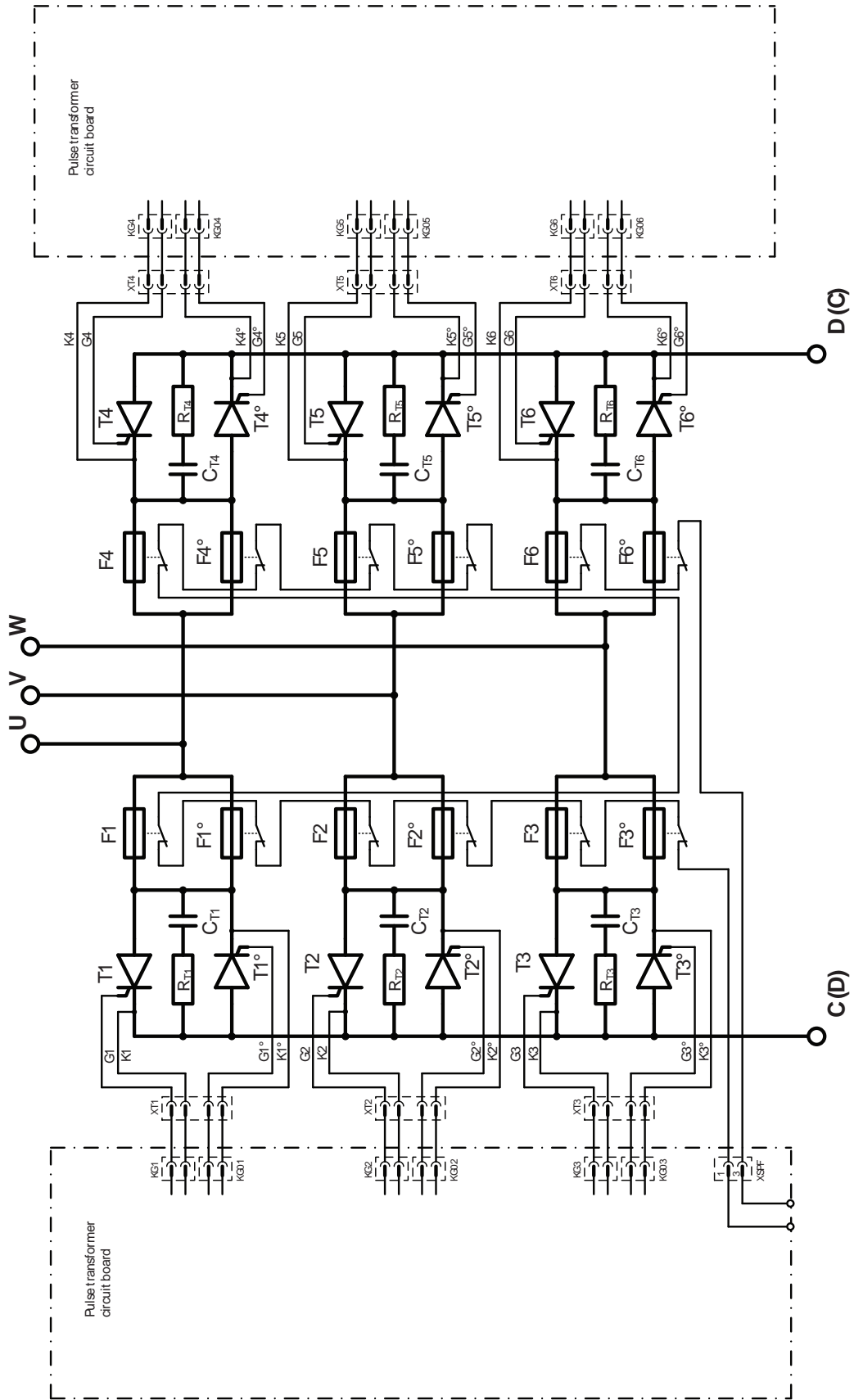

Figure 21 - AC Line Measurement Points Diagram

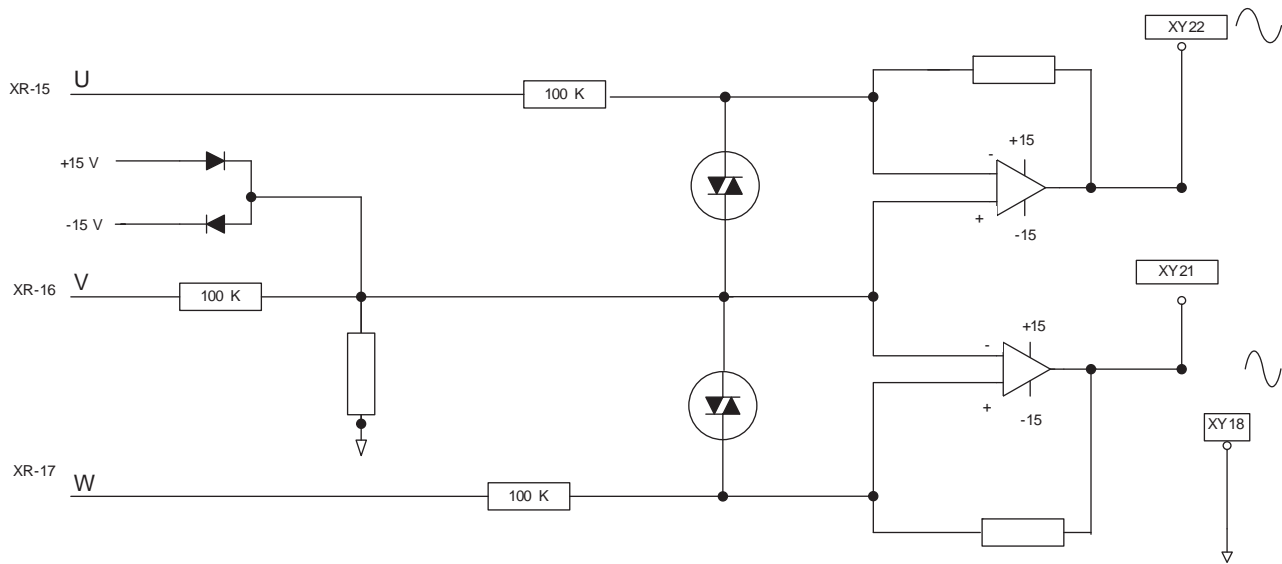

Figure 22 - Power Feedback Connections Diagram

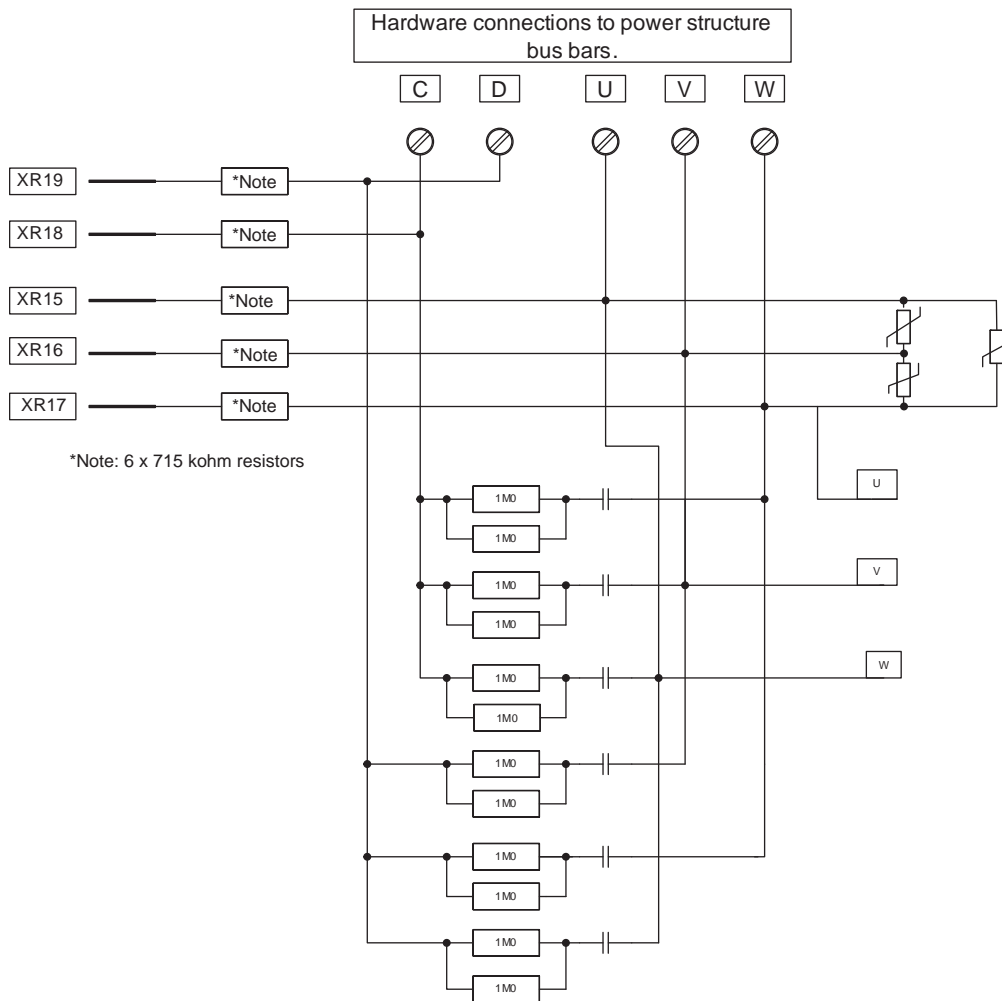

Figure 23 - Field Board and SCR/Dual Diode Module Connections Diagram

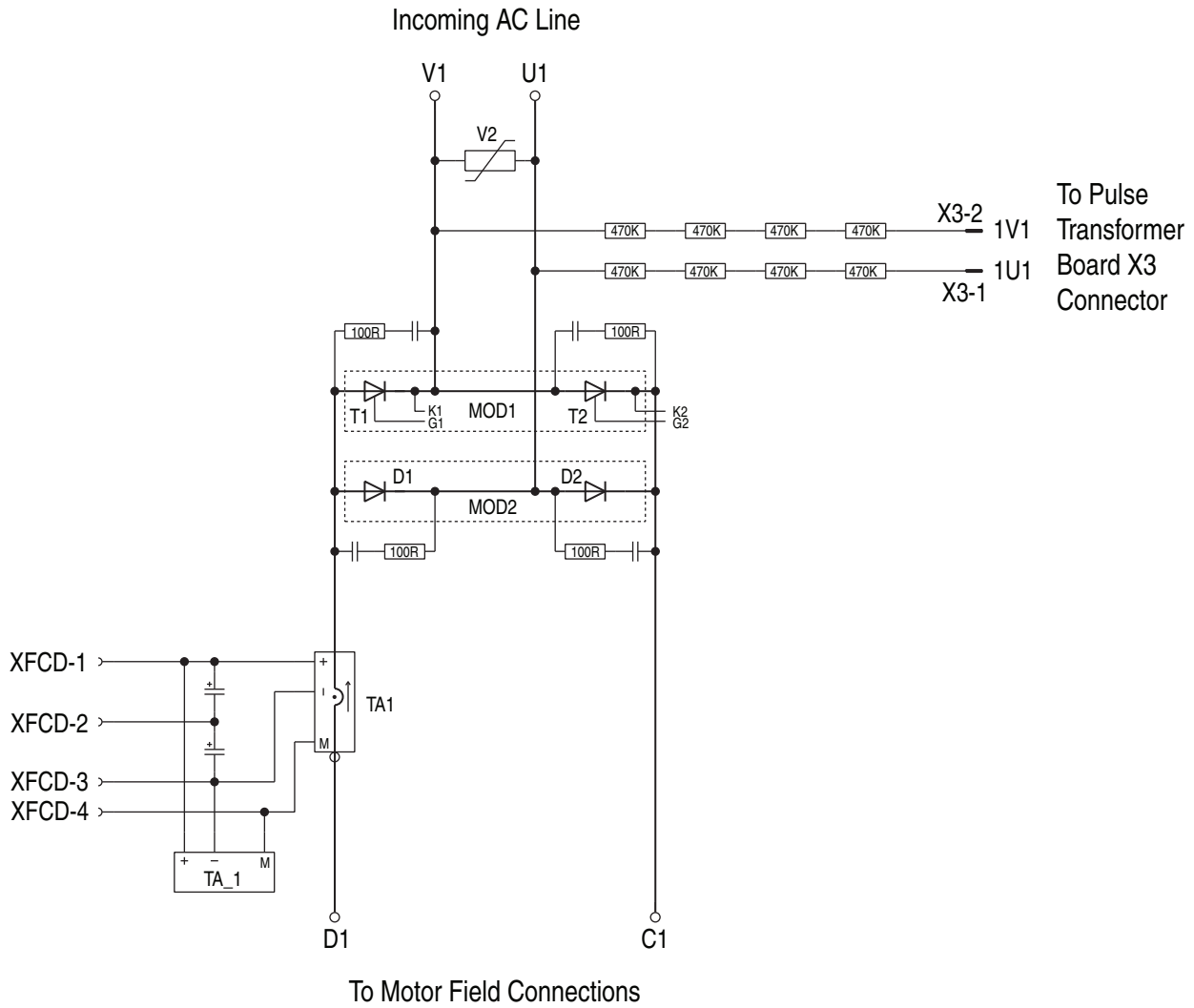

Figure 24 - Field Control Circuit Diagram

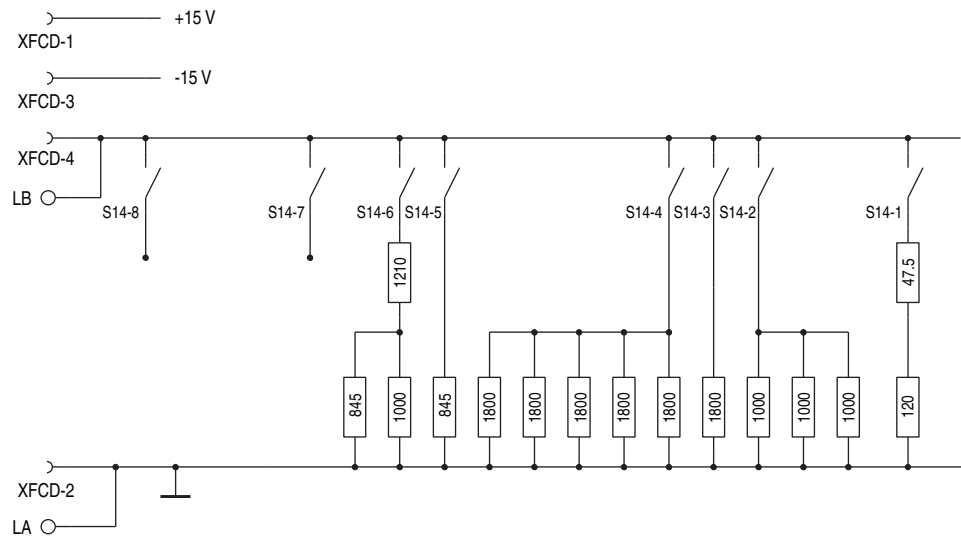

Figure 25 - Control Circuit Input Power Diagram

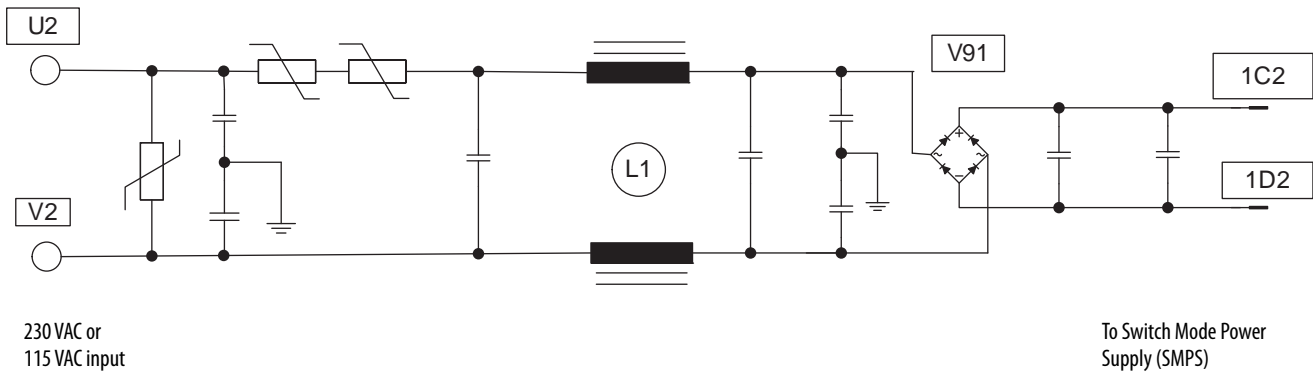

Figure 26 - Encoder Control Circuit Diagram

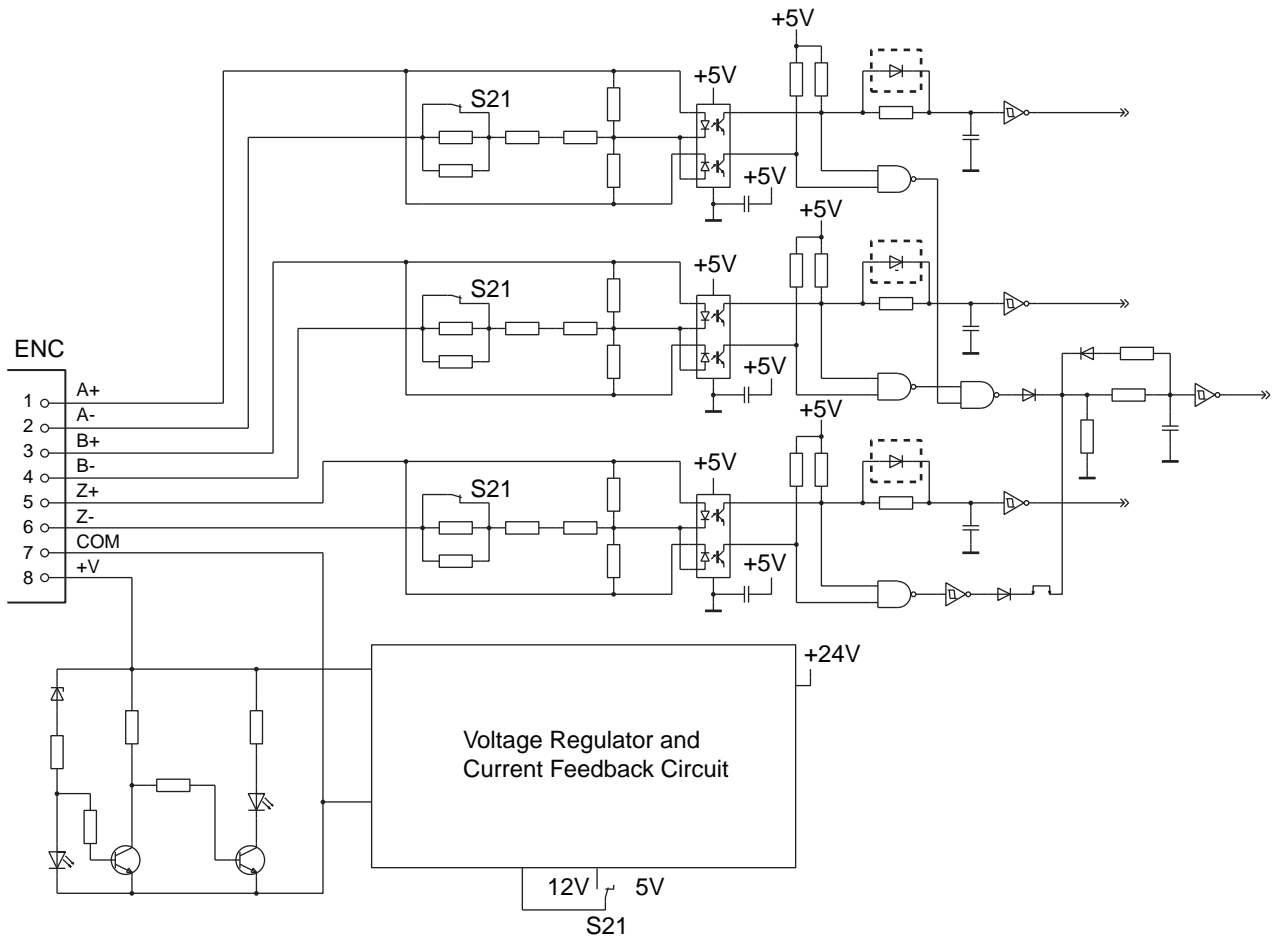

Figure 27 - DC Tachometer Control Circuit Diagram

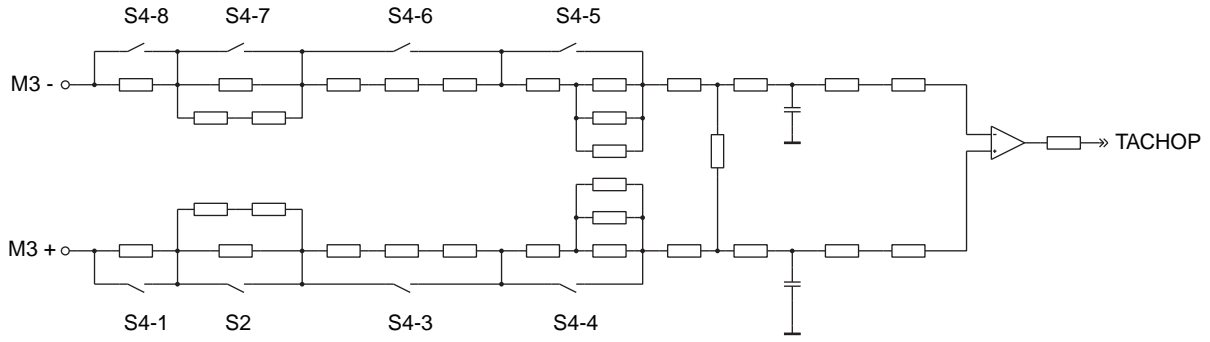

Figure 28 - Motor Thermal Protection Control Circuit Diagram

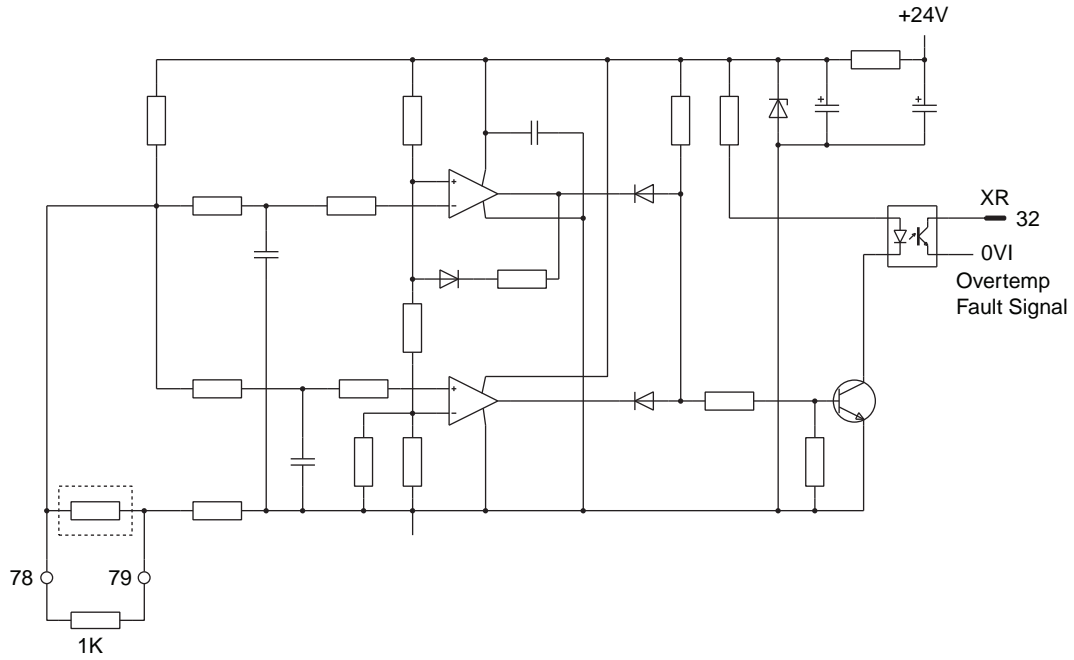

Figure 29 - Drive Heatsink Monitoring Control Circuit Diagram

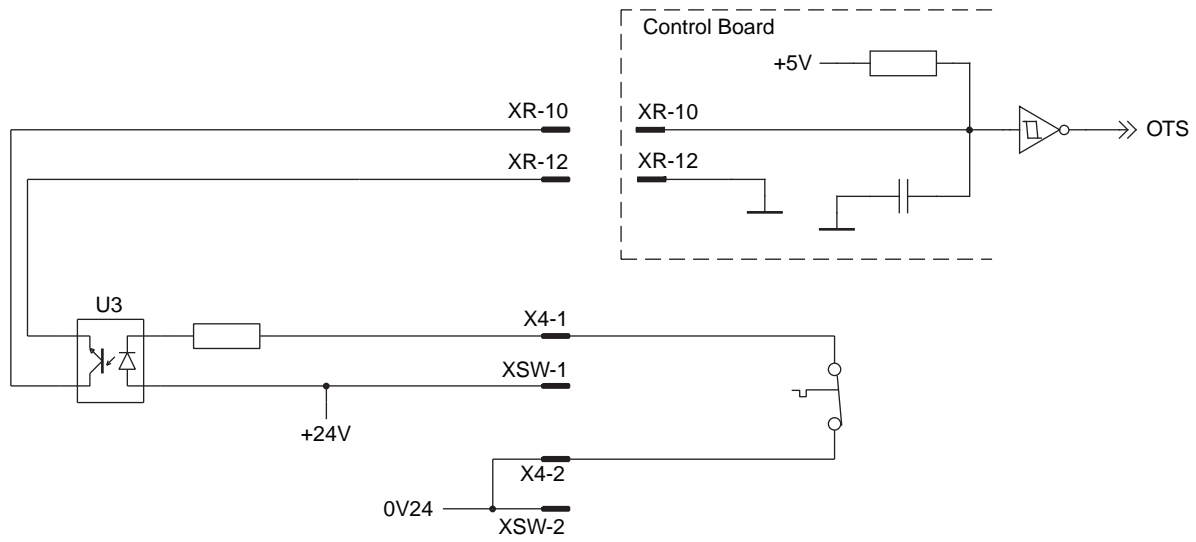

Figure 30 - Contactor Control Relays Control Circuit Diagram

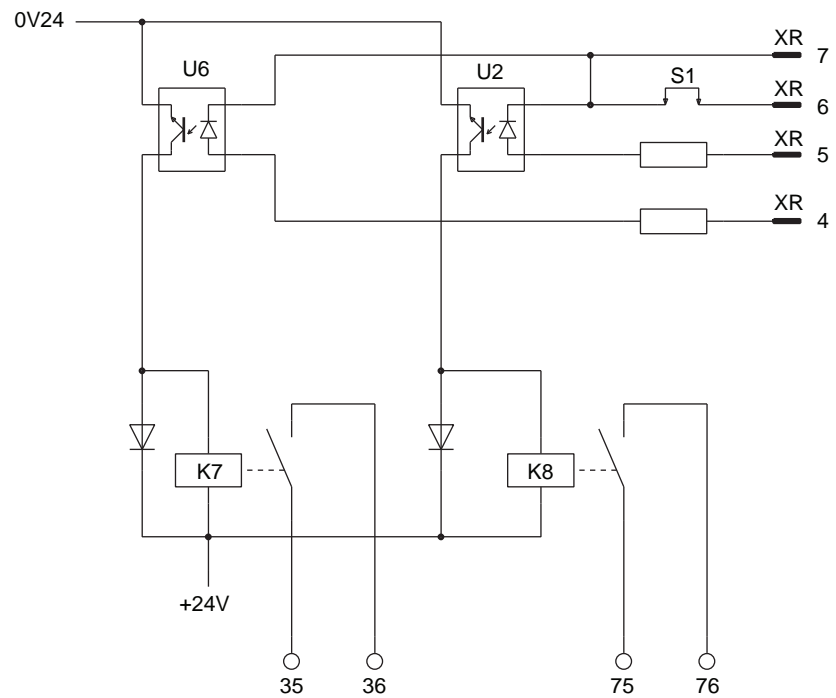

Figure 31 - Series A Fan Circuit Diagram

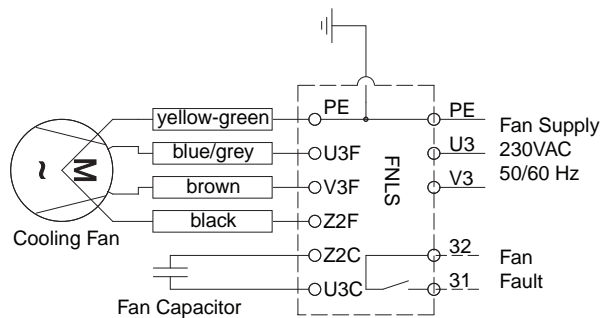

Figure 32 - Series B Fan Circuit Diagram

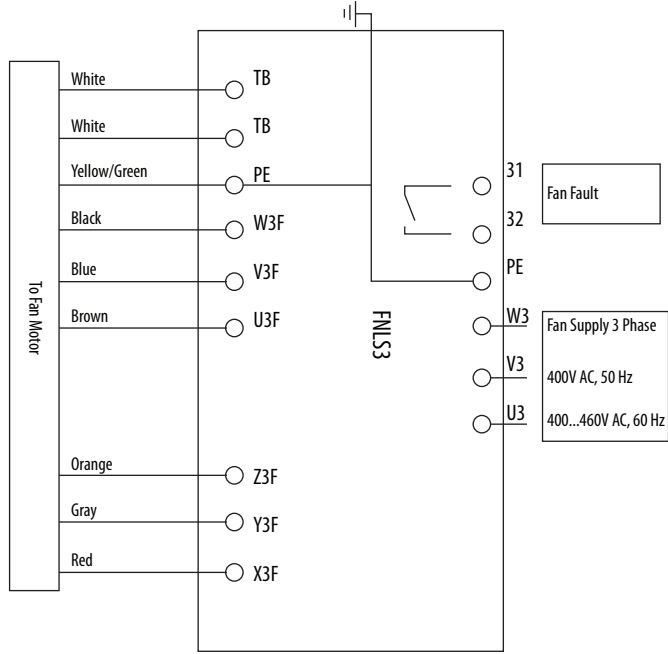
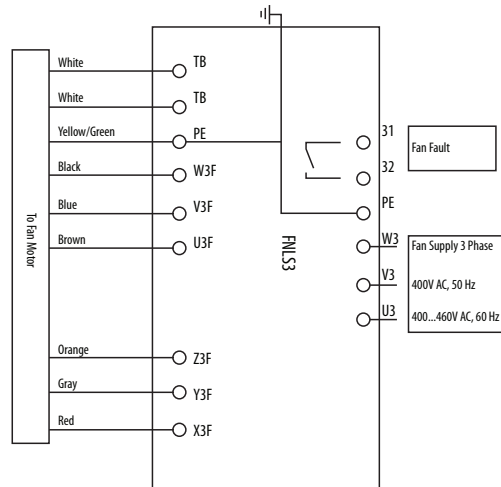

Figure 33 - Series C Fan Circuit Diagram



## Circuit Board Layouts and Connections

### List of Circuit Board Layouts

The following images and tables detail the connection points for the frame D TPDflex DC Converter circuit boards and components.

<b>Topic</b>	<b>Page</b>
Pulse Transformer Board Layout	128
Pulse Transformer Board to Field Board Connections	129
Pulse Transformer Board to Switching Power Supply Connections	129
Pulse Transformer Board to Bimetal Thermostat Connections	129
Pulse Transformer Board to Field SCR/Dual Diode Module Connections	129
Pulse Transformer Board to Control Board Connections	130
Pulse Transformer Board to Current Transducer Connections	130
Switching Power Supply Board Layout	131
Switching Power Supply Board to Control Board Connections	131
Control Board Layout	132
Control Board to Field Board Connections	132
Field Board Layout	134
Overvoltage Clipping Board	134
Overvoltage Clipping Board to Pulse Transformer Board Connections	135

# Pulse Transformer Board

Figure 34 - Pulse Transformer Board Layout

Components shown within dashed lines are only on the pulse transformer board for regenerative drives.

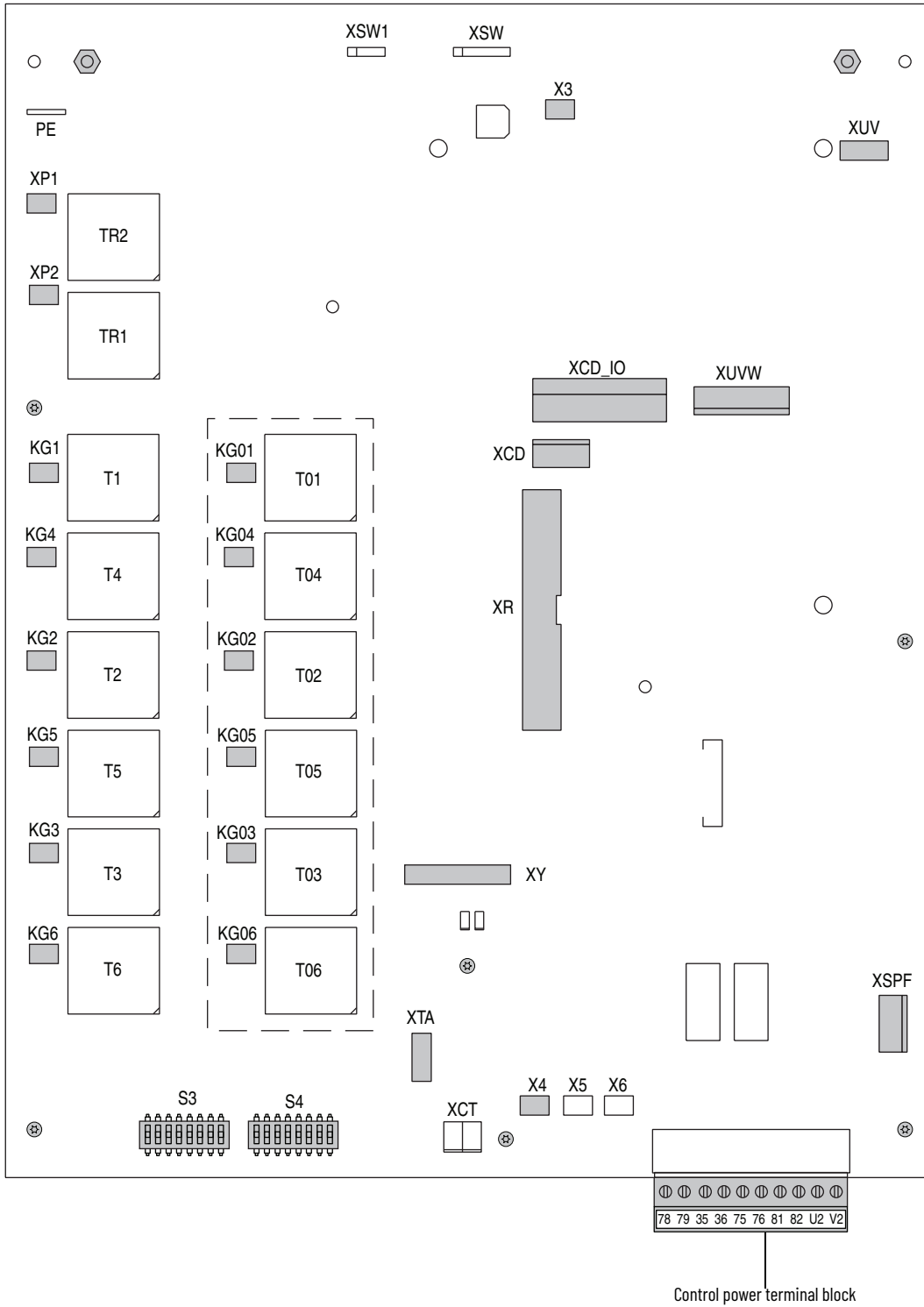

Table 17 - Pulse Transformer Board to Field Board Connections

Pulse Transformer Board Connector	Pin Number	to	Pin Number	Field Board Connector	Description
X3	1	...	1	X3	1U1 field sync signal (from U1)
	2	...	2		1V1 field sync signal (from V1)

Table 18 - Pulse Transformer Board to Switching Power Supply Connections

Pulse Transformer Board Point	to	Pin Number	Switching Power Supply Board Connector	Description
1C2	...	4	XUV	Rectified U2-V2 voltage (approx. 150/300V DC)
	...	3		not used
1D2	...	2		not used
	...	1		Common

Table 19 - Pulse Transformer Board to Bimetal Thermostat Connections

Pulse Transformer Board Connector	Pin Number	to	Pin Number	Bimetal Thermostat Connector	Description
X4	1	...	1	X4	+24V supply through resistor
	2	...	2		24V common

Table 20 - Pulse Transformer Board to Field SCR/Dual Diode Module Connections

Pulse Transformer Board Connector	Pin Number	to	Pin Number	Field SCR/Dual Diode Module Connector	Description
XP	1	...	3	Fastons	Gate signal G1
	2	...	2		Common cathode (K1 and K2) for both field SCRs
	3	...	2		
	4	...	1		Gate signal G2

Table 21 - Pulse Transformer Board to Control Board Connections

Pulse Transformer Board Connector	Pin Number	to	Pin Number	Control Board Connector	Description
XR	1	...	1	XR	Gate signal G1 field SCR1
	2	...	2		Gate signal G2 field SCR2
	3	...	3		OV (GNDP)
	4	...	4		Relay output 35-36 command
	5	...	5		Relay output 75-76 command
	6	...	6		2Q/4Q selection signal
	7	...	7		OV (GNDP)
	8	...	8		I armature = 0 signal
	9	...	9		OV (GNDP)
	10	...	10		Heatsink overtemperature
	11	...	11		Digital U1-V1 sync signal
	12	...	12		OV (GNDP)
	13	...	13		CT burden signal
	14	...	14		OV (GND)
	15	...	15		Reduced U sync signal
	16	...	16		Reduced V sync signal
	17	...	17		Reduced W sync signal
	18	...	18		Reduced C (armature) signal
	19	...	19		Reduced D (armature) signal
	20	...	20		OV (GNDP)
	21	...	21		Gate signal SCR 4/01
	22	...	22		OV (GNDP)
	23	...	23		Gate signal SCR 5/02
	24	...	24		OV (GNDP)
	25	...	25		Gate signal SCR 6/03
	26	...	26		WH1 (not used, grounded)
	27	...	27		Gate signal SCR 1/04
	28	...	28		WL1 (not used, grounded)
	29	...	29		Gate signal SCR 2/05
	30	...	30		OV (GNDP)
	31	...	31		Gate signal SCR 3/06
	32	...	32		Motor overtemperature
	33	...	33		Enable reverse (MN) power bridge
	34	...	34		Enable forward (MP) power bridge

Table 22 - Pulse Transformer Board to Current Transducer Connections

Pulse Transformer Board Connector	Pin Number	to	Pin Number	Current Transducer	Description
XTA	1	...	Red	CT on Phase U	Secondary side CT phase U
	2	...	White		
	3	...	Red	CT on Phase W	Secondary side CT phase W
	4	...	White		

# Switching Power Supply Board

Figure 35 - Switching Power Supply Board Layout

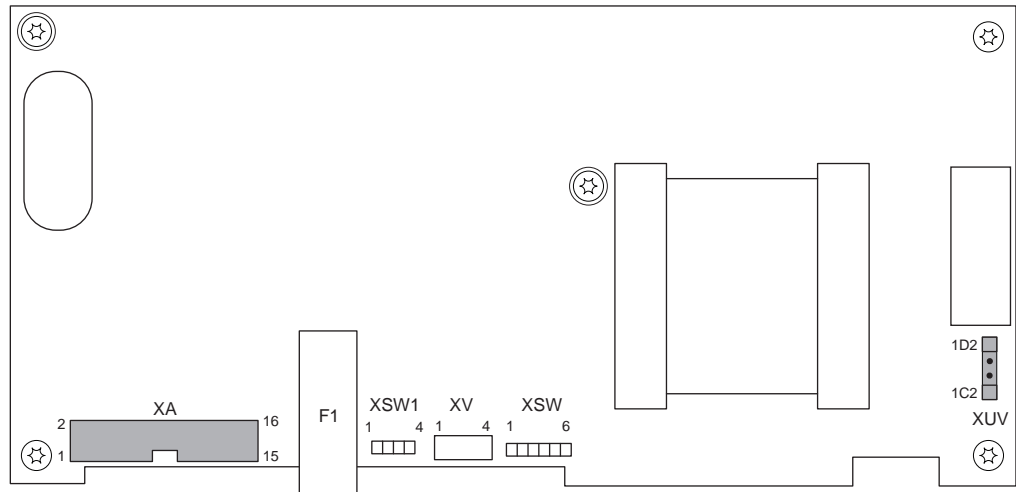

Table 23 - Switching Power Supply Board to Control Board Connections

Switching Power Supply Board Connector	Pin Number	to	Pin Number	Control Board Connector	Description
XA	1	...	1	XA	+5V
	2	...	2		5V common
	3	...	3		+5V
	4	...	4		5V common
	5	...	5		+5V
	6	...	6		5V common
	7	...	7		SMPS supply input undervoltage
	8	...	8		
	9	...	9		+15V
	10	...	10		
	11	...	11		15V common
	12	...	12		
	13	...	13		-15V
	14	...	14		
	15	...	15		24V common
	16	...	16		+24V

See Pulse Transformer Board to Switching Power Supply Connections on page [129](#).

# Control Board

Figure 36 - Control Board Layout

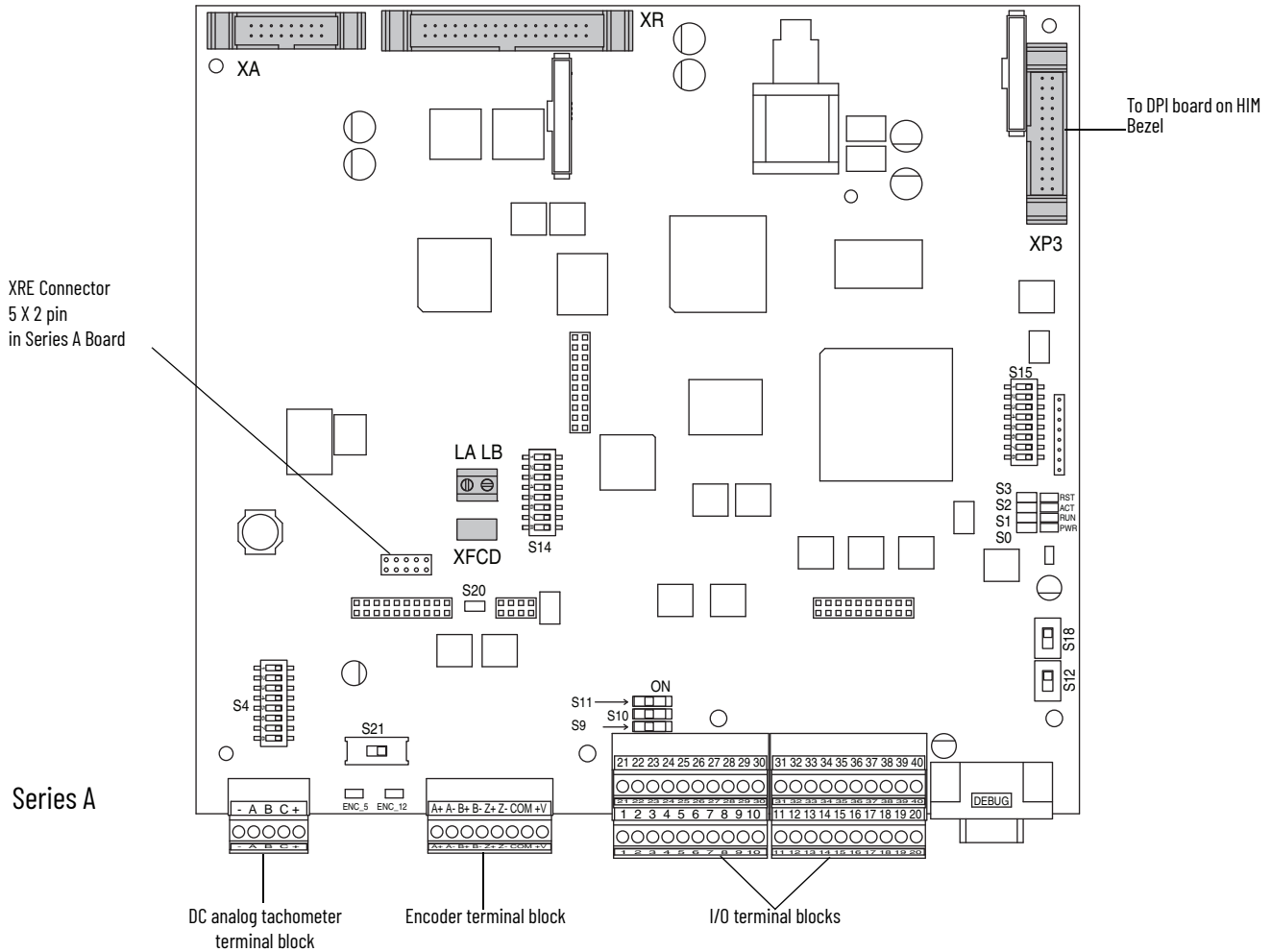

Table 24 - Control Board to Field Board Connections

Control Board Connector	Pin Number	to	Pin Number	Field Board Connector	Description
XFC	1	...	1	XFC	+15V
	2	...	2		15V Common
	3	...	3		-15V
	4	...	4		Field CT burden resistors

See Pulse Transformer Board to Control Board Connections on page [130](#) and Switching Power Supply Board to Control Board Connections on page [131](#).

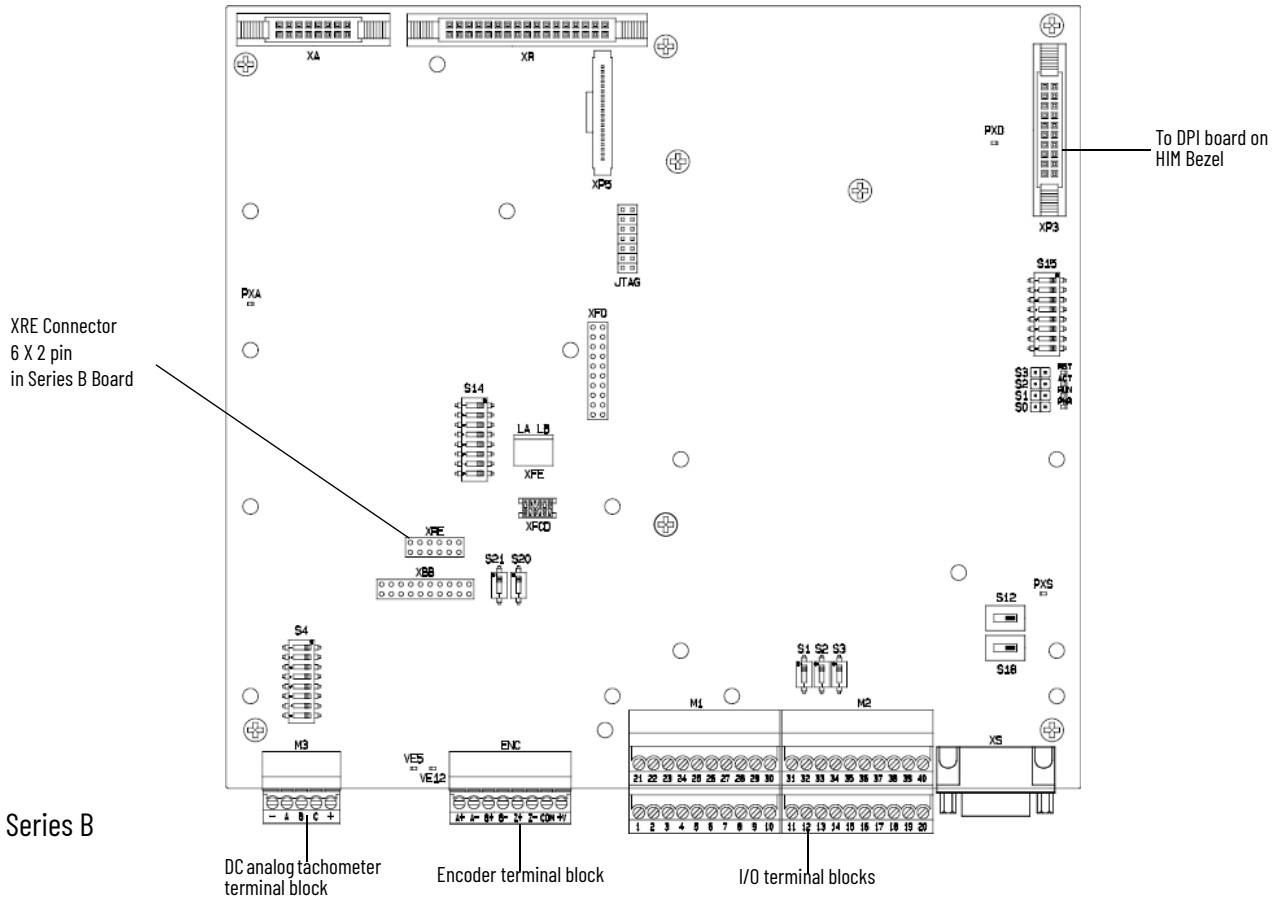

Figure 37 - Control Board to Field Board Connection Sees B

Control Board Connector	Pin Number	to	Pin Number	Field Board Connector	Description
XFCD-5	1	...	1	XFCD	+15V
	2	...	2		15V Common
	3	...	3		-15V
	4	...	4		Field CT burden resistors

See Pulse Transformer Board to Control Board Connections on page 130 and Switching Power Supply Board to Control Board Connections on page 131.

# Field Board

Figure 38 - Field Board Layout

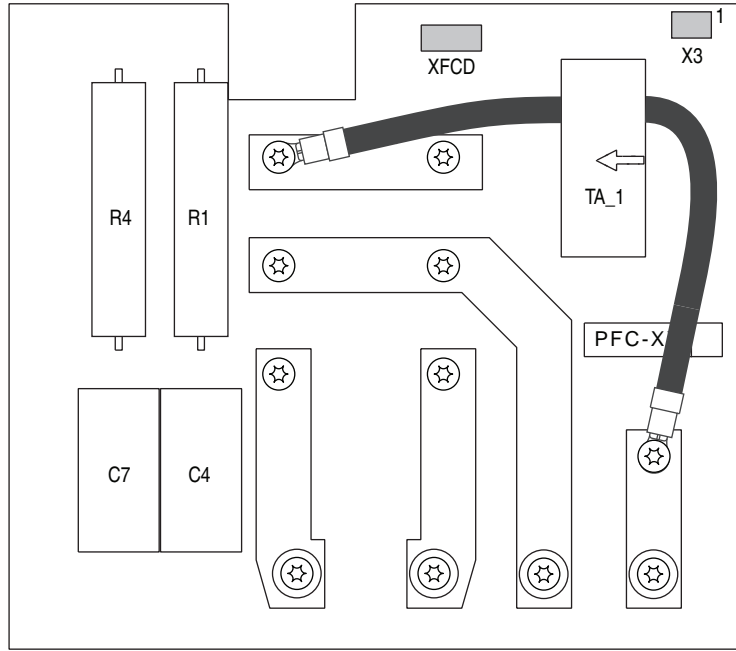

See Control Board to Field Board Connections on page 132 and Pulse Transformer Board to Field Board Connections on page 129.

# Overvoltage Clipping Board

Figure 39 - Overvoltage Clipping Board

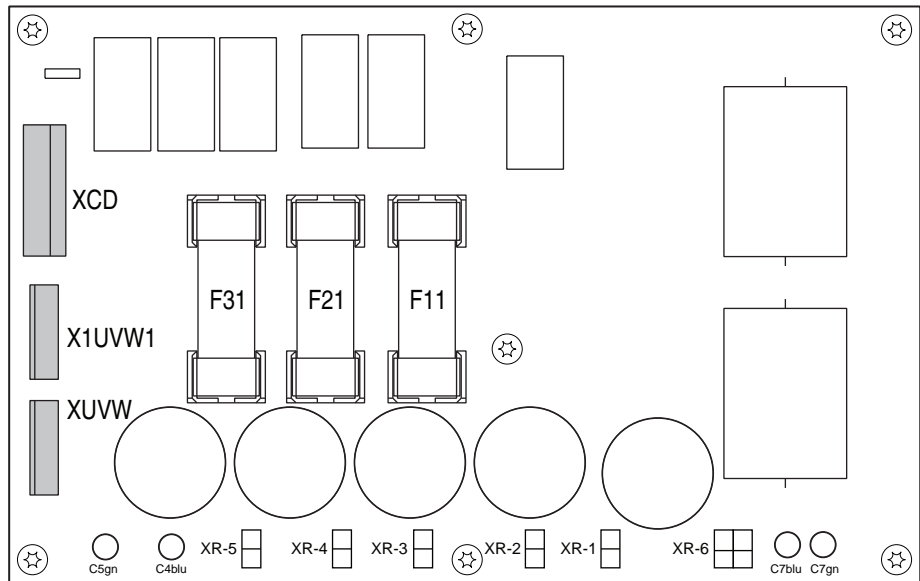

Table 25 - Overvoltage Clipping Board to Pulse Transformer Board Connections

Overvoltage Clipping Board Connector	Pin Number	to	Pin Number	Pulse Transformer Board Connector	Description
XCD	1	...	1	XCD	Signal from C Phase
	2	...	2		not used
	3	...	3		Signal from D Phase
	4	...	-	-	not used
	5	...	-	-	Signal from DC output terminal C
	6	...	-	-	not used
	7	...	-	-	Signal from DC output terminal D
X1UUVW1	1	...	1	XUVW	Signal from U Phase
	2	...	2		not used
	3	...	3		Signal from V Phase
	4	...	4		not used
	5	...	5		Signal from W Phase
XUVW	1	...	-	-	Signal from AC input terminal U
	2	...	-	-	not used
	3	...	-	-	Signal from AC input terminal V
	4	...	-	-	not used
	5	...	-	-	Signal from AC input terminal W

## Notes:

## Flow Charts

### List of Flow Charts

The following pages contain flow chart versions of troubleshooting procedures contained in Chapter 2 - Component Test Procedures.

Topic	Page
Control Power Supply Failure	137
Field Current Loss Failure	138

### Control Power Supply Failure

This chart presents the steps for troubleshooting a Power Failure fault (F3).

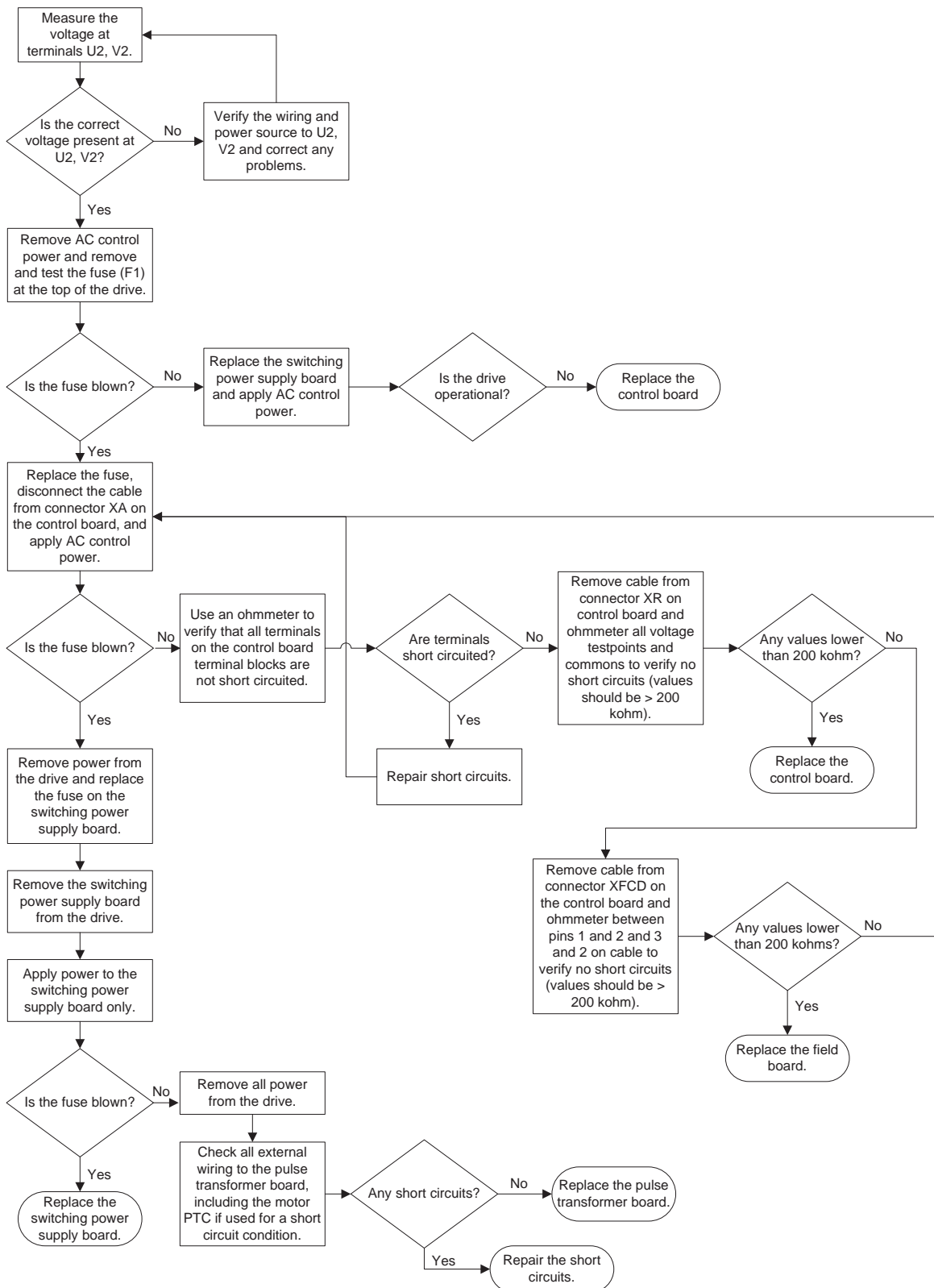

## Field Current Loss Failure

The charts below presents the steps in flow chart form for troubleshooting a Field Current Loss fault (F6).

## No Field Current

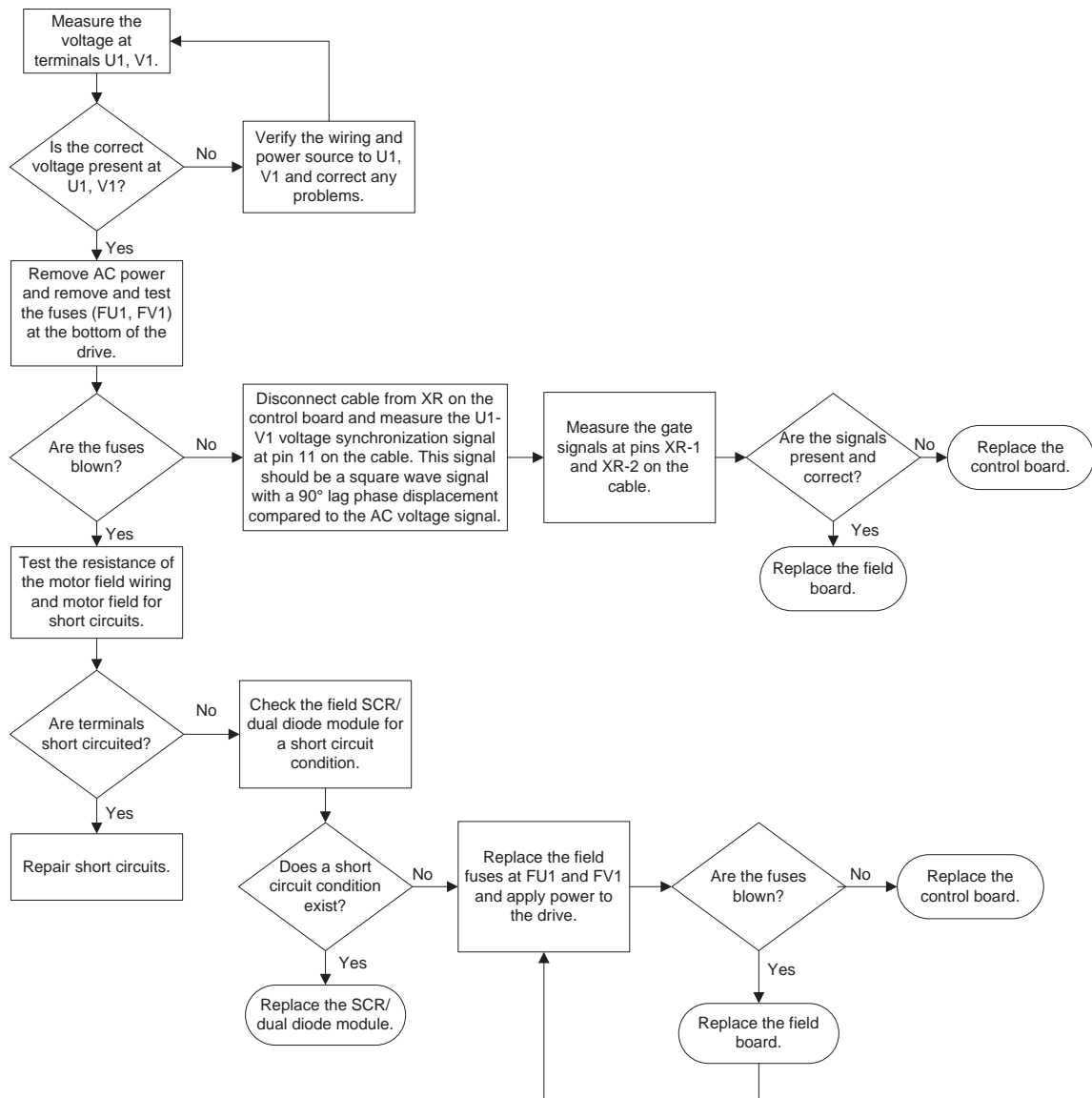

## Low or Incorrect Field Current

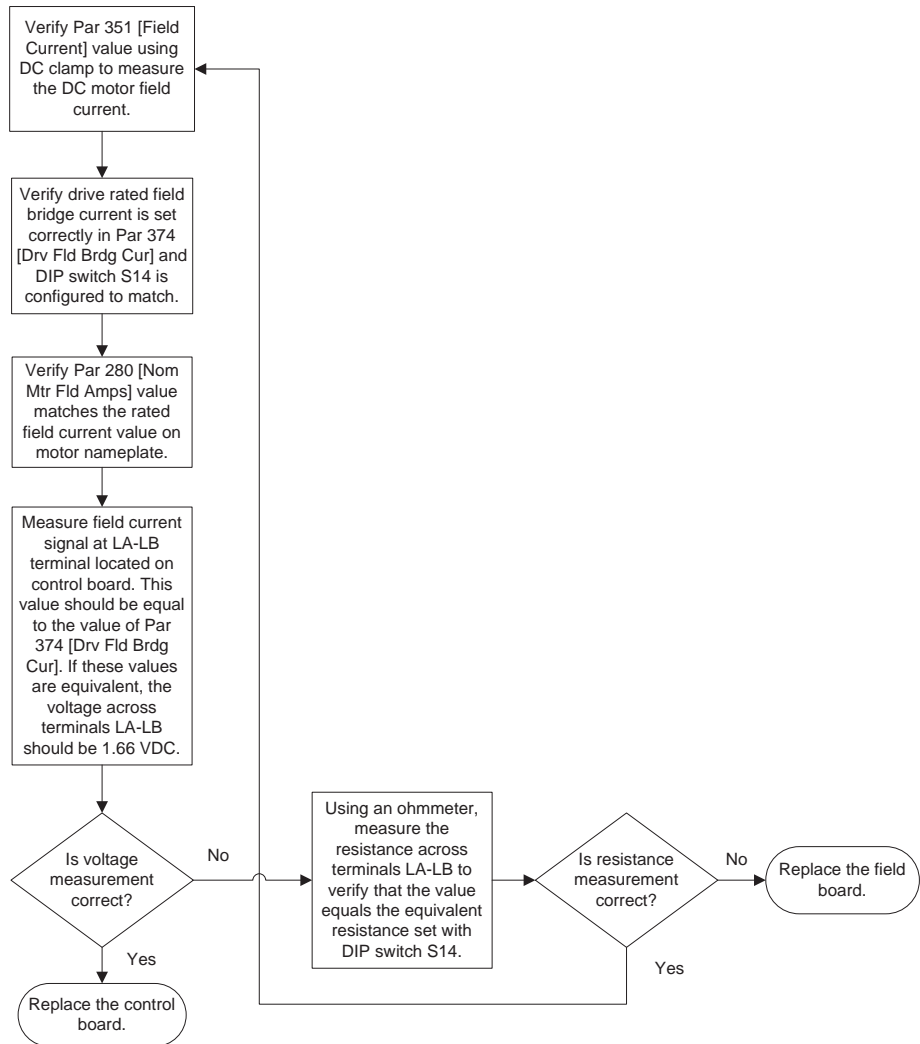

## Numerics

### 115V AC to 24V DC I/O converter board

install 62  
remove 61

## A

### AC current transducers

install 90  
remove 87

### armature leg fuse

install 94  
remove 93

### armature bridge failure

troubleshoot 23

### armature SCR modules

test 29

## B

### bimetal thermostat

install 101  
remove 101

## C

### circuit board

connections 125  
layout drawings 125

### communication adapter

install 53  
remove 52

### components

inspection 16

### contactor fault

40

### control board

install 65  
remove 63

### control power supply

failure 16

## D

### DC analog tachometer

test 37

### discharge resistors

install 103  
remove 101

### DPI/HIM assembly

install 48  
remove 48

## E

### Electrostatic Discharge Precaution

### encoder

test 36

## F

### fan circuit board - series A

install 79  
remove 79

### fan circuit board - series B

install 80  
remove 80

### fan starting capacitor

install 78  
remove 77

### fault

field current loss 25  
heatsink overtemperature 40  
main contactor 40  
overcurrent 23  
power failure 16

### fault report

create 41

### field circuit board

install 72  
remove 71

### field circuit fuses

install 47  
remove 47

### field current loss fault

### field dual diode module

install 74  
remove 72

### field fuse holder

install 77  
remove 75

### field SCR module

install 74  
remove 72

### field SCR/dual diode module

test 34

### frame size

### fuse

field circuit 47  
switching power supply 55  
switching power supply board 54

## H

### hardware description

### heatsink overtemperature

fault 40

## I

### I/O expansion board

install 61  
remove 60

### in-rush limiting resistor

install 105  
remove 103

### inspection

visual 16

**install**

115V AC to 24V DC I/O converter board 62  
 AC current transducers 90  
 amature leg fuse 94  
 bimetal thermostat 101  
 communication adapter 53  
 control board 65  
 discharge resistors 103  
 DPI/HIM assembly 48  
 fan circuit board - series A 79  
 fan circuit board - series B 80  
 fan starting capacitor 78  
 field circuit board 72  
 field circuit fuses 47  
 field dual diode module 74  
 field fuse holder 77  
 field SCR module 74  
 I/O expansion board 61  
 in-rush limiting resistor 105  
 interface circuit board 59  
 overvoltage clipping circuit board 93  
 overvoltage clipping circuit board fuses 91  
 protective covers 50  
 pulse transformer board 70  
 resolver feedback board 59  
 SCR module leg assembly 100  
 series A fan assembly 82  
 series A fan circuit board 79  
 series B fan assembly 84  
 series B fan circuit board 80  
 series C fan assembly 86  
 snubber capacitors 106  
 snubber resistors 108  
 switching power supply board 67  
 switching power supply fuse 55

**interface circuit board**

install 59  
 remove 56

**L****layout drawings**

circuit boards 125

**M****motor overheating** 40**O****outputs**

relay 40

**overcurrent fault** 23**overtemperature**

heatsink 40

**overvoltage clipping circuit board**

install 93  
 remove 92

**overvoltage clipping circuit board fuses**

install 91  
 remove 91

**P****parameter configuration**

save 14, 15, 16

**power**

removing 46

**power failure fault** 16**protective covers**

install 50  
 remove 49

**PTC** 40**pulse transformer board**

install 70  
 remove 67  
 test 33

**R****relay outputs** 40**remove**

115V AC to 24V DC I/O converter board 61  
 AC current transducers 87  
 amature leg fuse 93  
 bimetal thermostat 101  
 communication adapter 52  
 control board 63  
 DPI/HIM assembly 48  
 fan circuit board - series A 79  
 fan circuit board - series B 80  
 fan starting capacitor 77  
 field circuit board 71  
 field circuit fuses 47  
 field dual diode module 72  
 field fuse holder 75  
 field SCR module 72  
 I/O expansion board 60  
 in-rush limiting resistor 103  
 interface circuit board 56  
 overvoltage clipping circuit board 92  
 overvoltage clipping circuit board fuses 91  
 power 46  
 protective covers 49  
 pulse transformer board 67  
 resolver feedback board 56  
 SCR module leg assembly 95  
 series A fan assembly 81  
 series A fan circuit board 79  
 series B fan assembly 83  
 series B fan circuit board 80  
 series C fan assembly 85  
 snubber capacitors 105  
 snubber resistors 107  
 switching power supply board 66  
 switching power supply board fuse 54

**remvoe**

discharge resistors 101

**resolver feedback board**

install 59  
 remove 56

**S****safety precautions** 10**save parameter configuration** 14, 15, 16**schematic diagrams** 113**SCR module leg assembly**

install 100  
 remove 95

**series A fan assembly**

install 82  
remove 81

**series A fan circuit board**

install 79  
remove 79

**series B fan assembly**

install 84  
remove 83

**series B fan circuit board**

install 80  
remove 80

**series C fan assembly**

install 86  
remove 85

**service tools** 12**snubber capacitors**

install 106  
remove 105

**snubber resistors**

install 108  
remove 107

**software tools** 12**switching power supply board**

fuse 54  
install 67  
remove 66

**T****technical support**

calling 41

**test**

armature SCR modules 29  
DC analog tachometer 37  
encoder 36  
field SCR/dual diode module 34  
pulse transformer board 33

**testpoints**

locations 20, 21

**thermal switch** 40**thermistor** 40**tools**

service 12  
software 12

**troubleshoot**

armature bridge failure 23  
field current loss 25  
overcurrent fault 23  
power failure fault 16

**V****visual inspection** 16

**Notes:**

## Do you need help?

This drive is available exclusively through **Allen-Bradley distributors** and **Rockwell Automation drive systems**. If there are any questions, please contact your local **Allen-Bradley distributor** or **Rockwell Automation sales office**.

Support is offered by the **Rockwell Automation** TechConnect services, field service teams, product repair services and spare part availability.

## Rockwell Automation support

Use these resources to access support information.

<b>Technical Support Center</b>	Find help with how-to videos, FAQs, chat, user forums, Knowledgebase, and product notification updates.	<a href="http://rok.auto/support">rok.auto/support</a>
<b>Local Technical Support Phone Numbers</b>	Locate the telephone number for your country.	<a href="http://rok.auto/phonesupport">rok.auto/phonesupport</a>
<b>Product Compatibility and Download Center (PCDC)</b>	Download firmware, associated files (such as AOP, EDS, and DTM), and access product release notes.	<a href="http://rok.auto/pcdc">rok.auto/pcdc</a>
<b>Distributor Partner Locator</b>	Rockwell Automation partners with best-in-class partners worldwide to offer first-rate solutions for your business challenges. Search our Partner-Network database and connect with a partner today.	<a href="http://rockwellautomation.com/en-us/sales/partner-locator">rockwellautomation.com/en-us/sales/partner-locator</a>

## Documentation Feedback

Your comments help us serve your documentation needs better. If you have any suggestions on how to improve our content, contact us at [techdoc@weq.net](mailto:techdoc@weq.net).

## Waste Electrical and Electronic Equipment (WEEE)



At the end of life, this equipment should be collected separately from any unsorted municipal waste.

## Hardware Service Manual

Series: TPDflex

Revision: 0.1

Date: 10/02/2026

Codice: 1S7TFLEXD

## **WEG Automation Europe S.r.l.**

Via Giosuè Carducci, 24

21040 Gerenzano (VA) · Italy

[info.motion@weg.net](mailto:info.motion@weg.net)

Technical Assistance: [technohelp@weg.net](mailto:technohelp@weg.net)

Customer Service: [salesmotion@weg.net](mailto:salesmotion@weg.net)