

Instruction Manual

EXP-IO-D5R8-ADV

I/O Expansion card

- 4 Digital Inputs
- 1 Digital Output
- 8 Relay Outputs

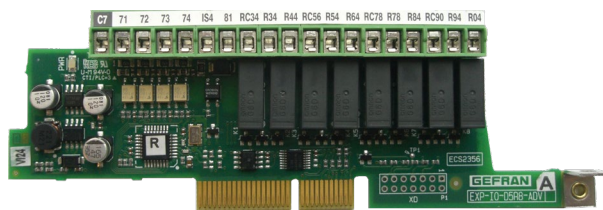

① Drive Requirements

The EXP-IO-D5R8-ADV card (cod. S5L38) is designed for the following AC drives:

- Drive Type: ADV200 WA (all versions); Recommended Firmware Release: 1.0 or later.
- Drive Type: ADV200 (all versions); Firmware Release: 7.0 or later.

② Description

The EXP-IO-D5R8-ADV is an optional expansion card for the ADV200 and ADV200 WA product family. This card enables the use of:

- 4 x Digital Inputs (NPN/PNP);
- 1 x programmable digital output (NPN/PNP);
- 8 x single contact relay outputs or 4 x double contact relay outputs.

About the Digital I/O:

- The NPN/PNP mode is manually configurable by means of a dedicated dip-switch;
- The output is programmable, the user can associate a specific function to control the 0 → 1 transition of the digital output. By way of example, in case of fan control it is possible to associate the “broken belt” function with a digital output, so that when the drive detects that the belt is broken, the 0 → 1 switch on the digital output is triggered. The full list of functions is provided in the ADV200 and ADV200 WA functional parameters handbook.

As regards relay outputs, the selection of single contact or double contact is software configurable by the user. This card should be used when the ADV200 WA drive type is required to drive a multi-pump system where each pump is individually controlled in an ON-OFF mode.

 **NOTE** The drive can host one single EXP-IO-D5R8-ADV card.

③ Connections

Details of card terminations are provided below:

C7	71	72	73	74	IS4	81	RC34	R34	44	RC56	R54	R64	RC78	R74	R89	RC90	R94	R04
----	----	----	----	----	-----	----	------	-----	----	------	-----	-----	------	-----	-----	------	-----	-----

Terminal	Name	Function	Max.
C7	COM Digital inputs	Common reference for digital inputs	---
71	Digital input 1X	Digital input 1X	5mA@+24V (max +30V)
72	Digital input 2X	Digital input 2X	5mA@+24V (max +30V)
73	Digital input 3X	Digital input 3X	5mA@+24V (max +30V)
74	Digital input 4X	Digital input 4X	5mA@+24V (max +30V)
IS4	PS Digital Output	Digital Output Power Supply	---
81	Digital output	Digital output 1X	+24V (typ), 40mA (max)
RC34	COM relay 1 and 2	Common relay 1 and 2	---
R34	Contact NO relay 1	Normally Open Programmable output relay 1	250Vac – 30Vdc – 2A
R44	Contact NO relay 2	Normally Open Programmable output relay 2	250Vac – 30Vdc – 2A
RC56	COM relay 3 and 4	Common relay 3 and 4	---
R54	Contact NO relay 3	Normally Open Programmable output relay 3	250Vac – 30Vdc – 2A
R64	Contact NO relay 4	Normally Open Programmable output relay 4	250Vac – 30Vdc – 2A
RC78	COM relay 5 and 6	Common relay 5 and 6	---
R74	Contact NO relay 5	Normally Open Programmable output relay 5	250Vac – 30Vdc – 2A
R89	Contact NO relay 6	Normally Open Programmable output relay 6	250Vac – 30Vdc – 2A
RC90	COM relay 7 and 8	Common relay 7 and 8	---
R94	Contact NO relay 7	Normally Open Programmable output relay 7	250Vac – 30Vdc – 2A
R04	Contact NO relay 8	Normally Open Programmable output relay 8	250Vac – 30Vdc – 2A

4 Functional Block Diagram

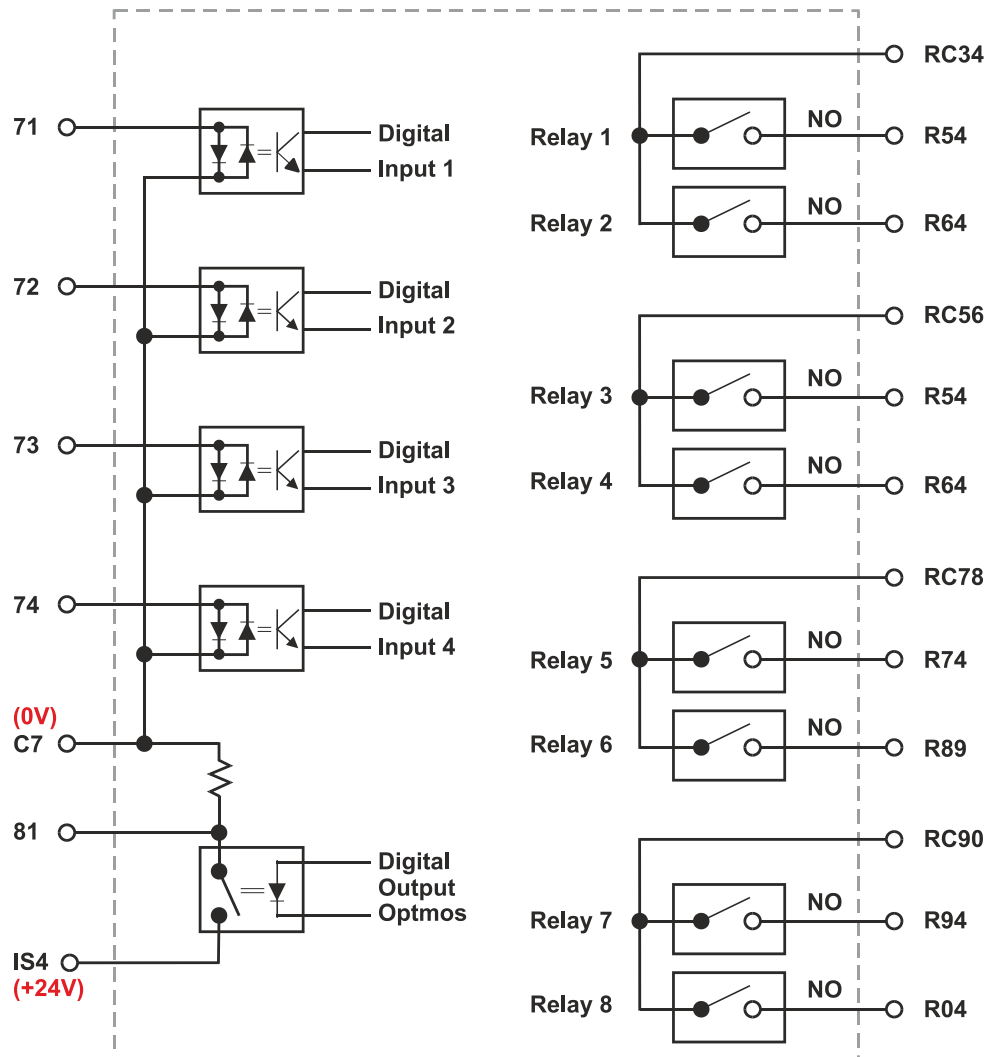

5 Installation

To install the card refer to the "Installation of optional cards" chapter in the "ADV200 WA and ADV200 Quick Start" installation handbook. This chapter describes the procedure for installing the I/O card.

During installation bear in mind the following:

- Do not connect an external voltage or current generator to the ports as specified in the connection table;
- The analog I/O terminations have no mutual galvanic insulation. Galvanic insulation is only available between the terminations and the control card.
- **CAUTION: Use only the supplied screws !**

6 Commissioning

Once the card is installed the commissioning phase can start. Use the keypad to go to menu 02, which will show that the card is properly recognized and ready to operate:

T+	T-	EN	LOC	Ilim	n=0	AL
<input type="checkbox"/>	<input type="checkbox"/>	<input type="checkbox"/>	<input type="checkbox"/>	<input type="checkbox"/>	<input checked="" type="checkbox"/>	<input type="checkbox"/>
02.15		PAR:		530		
Slot1 card type						
I/O 7						
Value:		6401				

T+	T-	EN	LOC	Ilim	n=0	AL
<input type="checkbox"/>	<input type="checkbox"/>	<input type="checkbox"/>	<input type="checkbox"/>	<input type="checkbox"/>	<input checked="" type="checkbox"/>	<input type="checkbox"/>
02.16		PAR:		530		
Slot2 card type						
I/O 7						
Value:		6401				



NOTE I/O 7 identifies the EXP-IO-D5R8-ADV card. The Slot where the card is plugged in is shown

7 Ordering Information

When ordering the EXP-IO-D5R8-ADV card please quote commercial code: **S5L38**.